

# UJB Wireless Kit

Control Systems

---

## USER'S MANUAL

---

M1S614EA – *Translation of the original instructions*

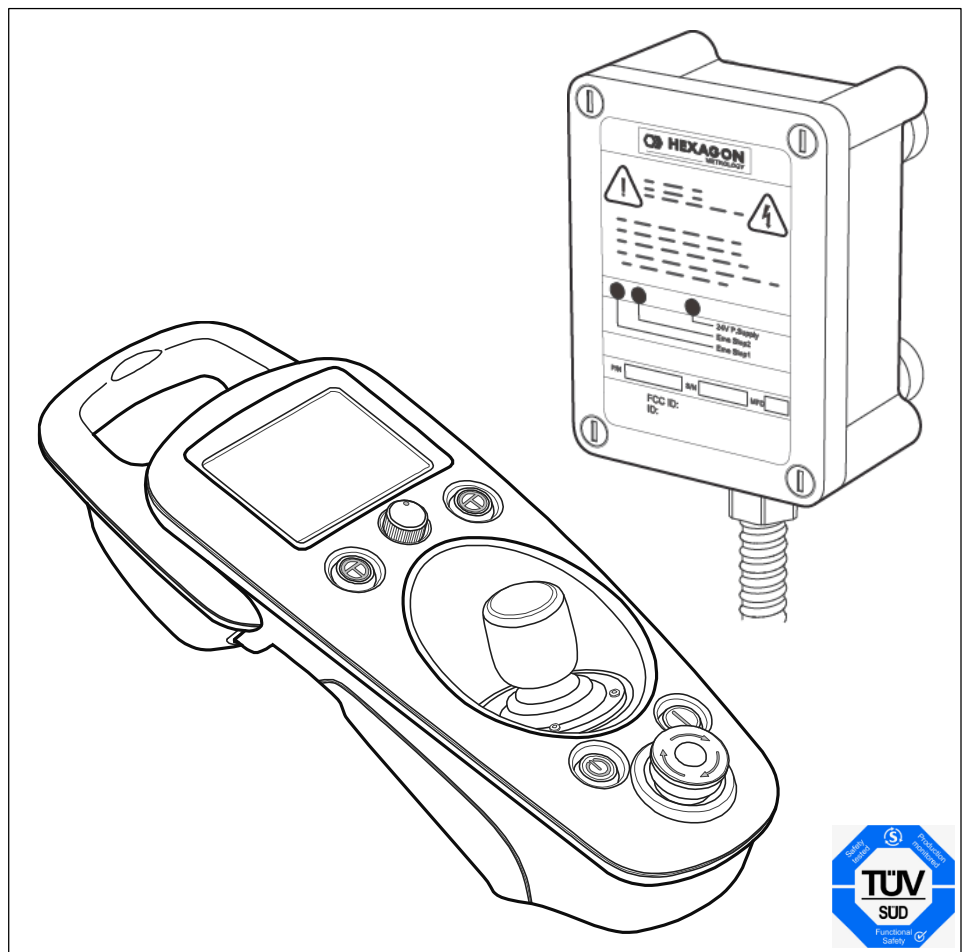

*Serving Metrology Worldwide*



© Hexagon Metrology, November 2012

Third party trademarks: Hexagon Metrology S.p.A. acknowledges all trademarks and registered trademarks that are the property of their legal owners.

Hexagon Metrology declares that the information provided in this document was correct on the date of publication; this information may be changed without notice to bring it into line with improvements in the performance and quality of its products.

Hexagon Metrology declines all liability for any errors that may appear in the manual.

The contents of this document are strictly confidential and the consignee is obliged to use it exclusively for his own purposes.

This manual cannot be given, lent or copied, either wholly or in part, without written authorization from Hexagon Metrology.



**Hexagon Metrology Services Ltd.**

World Headquarters Office  
Cedar House  
78 Portsmouth Road  
Cobham, Surrey  
KT11 1AN  
Great Britain  
Tel: +44 (0)20 8600 7240  
Fax +44 (0)20 8600 7231  
Internet: <http://www.hexagonmetrology.com>



**Hexagon Metrology S.p.A.**

Strada del Portone, 113  
10095 Grugliasco (TO), Italy  
Tel: +39 011 4025 111  
Fax: +39 011 7803 254  
Internet: <http://www.dea.it>



**Hexagon Metrology, Inc.**

250 Circuit Drive  
North Kingstown, Rhode Island 02852, U.S.A.  
Tel: +1 (401) 886 2000  
Fax: +1 (401) 886 2727  
Internet: <http://www.brownandsharpe.com>



**Hexagon Metrology, GmbH**

Siegmund-Hiepe-Straße 2-12  
D-35578 Wetzlar, Germany  
Tel: +49 (0) 6441 207 0  
Fax: +49 (0) 6441 207 122  
Internet: <http://www.leitz-metrology.com>



**Hexagon Metrology (Qingdao) Co., Ltd.**

188 Zhuzhou Road  
Qingdao, 266101, P.R. China  
Tel: +86 (532) 8870 2188  
Fax: +86 (532) 8870 3060  
Internet: <http://www.hexagonmetrology.com.cn>

Hexagon Metrology is part of Hexagon Measurement Technologies, a business area within the Hexagon group. Internet: <http://www.hexagonmetrology.net>

---

*Serving Metrology Worldwide*

# Contents

<b>Preface</b>	<b>v</b>
Documentation Provided with the UJB Kit .....	vi
Consulting the documentation .....	vi
Opening PDF files .....	vi
Conventions .....	vi
Safety Information .....	vi
<b>General information</b>	<b>1</b>
Introduction .....	2
Theory of operation .....	3
UJB Kit composition .....	4
Technical Data .....	5
General Characteristics.....	5
Wireless communication characteristics.....	5
UJB Wireless Portable Unit characteristics .....	5
UJB Wireless Base Unit characteristics .....	6
Bluetooth radio module characteristics (optional).....	6
Compliance to standards.....	6
Directives and safety standards .....	6
FCC (Federal Communications Commission).....	7
IC (Industry Canada).....	7
UJB Kit installation and maintenance.....	7
External Host Interface.....	8
<b>Instructions for use</b>	<b>9</b>
Safety precautions for the use of the UJB Kit.....	10
Commands and signals of the Portable Unit.....	11
Unit Operation .....	12
Touch Screen Functionality Reference .....	17
UJB Wireless Portable Unit Use Instructions .....	18
Switching ON/OFF the unit.....	18
UJB Wireless Portable Unit Command Reference .....	19
Moving the Machine Axes from the Portable Unit.....	22
Managing an Emergency Condition .....	23
<b>User Service Graphics Reference</b>	<b>25</b>
User Service Reference.....	26
Service Screen 1 - Build and Version info .....	26
Service Screen 2 – Audio Settings .....	26
Service Screen 3 – Analog Monitor .....	27
Service Screen 4 – Input Monitor.....	27
Service Screen 5 – Output Monitor .....	28
Service Screen 6 – Advanced Options.....	28
Service Screen 7 – Backlight Settings .....	29
<b>Advanced Service Graphics Reference</b>	<b>31</b>
Advanced Service Reference .....	32

Service Screen 9 – Advanced Functions.....	32
Tools & Settings Screen 1 – Default Settings Editor.....	33
Tools & Settings Screen 2 – Audio Settings.....	33
Tools & Settings Screen 3 – Backlight Settings .....	34
Tools & Settings Screen 4 – Joystick Settings.....	34
Tools & Settings Screen 5 – Reference Test .....	35
Tools & Settings Screen 6 – Protocol Settings .....	35
Screen Calibration .....	35

**UJB Portable Unit Maintenance 37**

General.....	38
Touch screen and buttons .....	38
Charging the Battery Pack .....	38
Inserting the Battery Pack.....	40
Battery pack characteristics .....	41
Battery Pack technical data.....	41
Battery pack warnings .....	41
Docking Station .....	42
Docking Station warnings.....	42
AC/DC Adapter .....	43
AC/DC Adapter technical data .....	43
AC/DC Adapter use warnings .....	43
AC/DC Adapter maintenance .....	44
Using the UJB Kit in a dual-arm measuring system .....	44

**UJB Quick Reference Guide 45**

# Preface

The present document describes the UJB Wireless Kit (hereafter UJB Kit) and is intended for use by the system's user and by the service personnel.

A knowledge of the information given in this manual is essential in order to use the UJB kit and perform a correct maintenance.

Users and service personnel are advised to read it carefully before using the system or proceeding with any maintenance procedure.

---

# Documentation Provided with the UJB Kit

The UJB Kit includes the following documents:

- UJB Wireless Kit – Installation Instructions (the present manual)
- UJB Wireless Kit – User's Manual
- CE conformity declaration for the UJB Wireless kit (European version)

---

## Consulting the documentation

### Opening PDF files

The documents in PDF (Portable Document Format) format may be read using the Adobe's Acrobat Reader viewer. You can start Acrobat Reader directly from the compact disc or by first copying it on your Personal Computer and then starting it. You can also install Acrobat Reader on your Personal Computer downloading it from the Adobe's Web site (<http://www.adobe.com>).

---

## Conventions

The following conventions are used in this manual to distinguish between various kinds of information.

---

**Note.** Notes give important information taken from the text, which may be useful in ensuring that the equipment is used to its full potential.

---

### **CAUTION**

*Caution messages indicate potential damage to the equipment or loss of data and tell you how to avoid the problem.*

---



### **WARNING**

**Warning messages indicate the potential for bodily harm and tell you how to avoid the problem.**

---

---

## Safety Information

All the operations described in this document for which you are responsible must be performed in respect of the national and company safety regulations.

# General information

This chapter describes the features and the technical characteristics of the UJB Kit.

---

## Introduction

The Universal Jogbox (UJB) is a portable device of the Hexagon Metrology (HexMet ) measuring systems that allows performing many operations while standing close to the CMM.

For example, you can move the machine axes using the joystick lever or perform manual operations while self-teaching a part program under the control of the measuring software.

You can also activate CNC motion in Manual Mode at low speed, keeping one of the Enable pushbuttons pressed.

The UJB is meant to be used together with a HexMet coordinate measuring machine (CMM), controlled by a HexMet electronic controller consisting of proprietary hardware and firmware (resident software).

It can also be used together with non-proprietary CMMs, provided that they are equipped with a HexMet controller and integrated with the safety features required on the basis of a risk analysis.

A UJB cannot be used for general purposes.

In its standard version, the UJB is connected to the control system by a special cable, 7 or 15 m long. In particularly long machines and under particular operating conditions, a cable connected UJB may interfere with operation. It should therefore be replaced by a wireless system that makes operation easier and safer for the user.

The wireless kit is a HexMet optional component replacing the standard UJB. It consists of a wireless UJB Portable Unit and a Base Unit.

The operation of the two devices (standard and wireless UJB) is identical. Layout, functions and features of the two devices are identical with the addition, in the case of the wireless version, of some controls relative to the wireless connection and to the battery pack state.

The following figure shows a one-arm measuring system equipped with the UJB Kit.

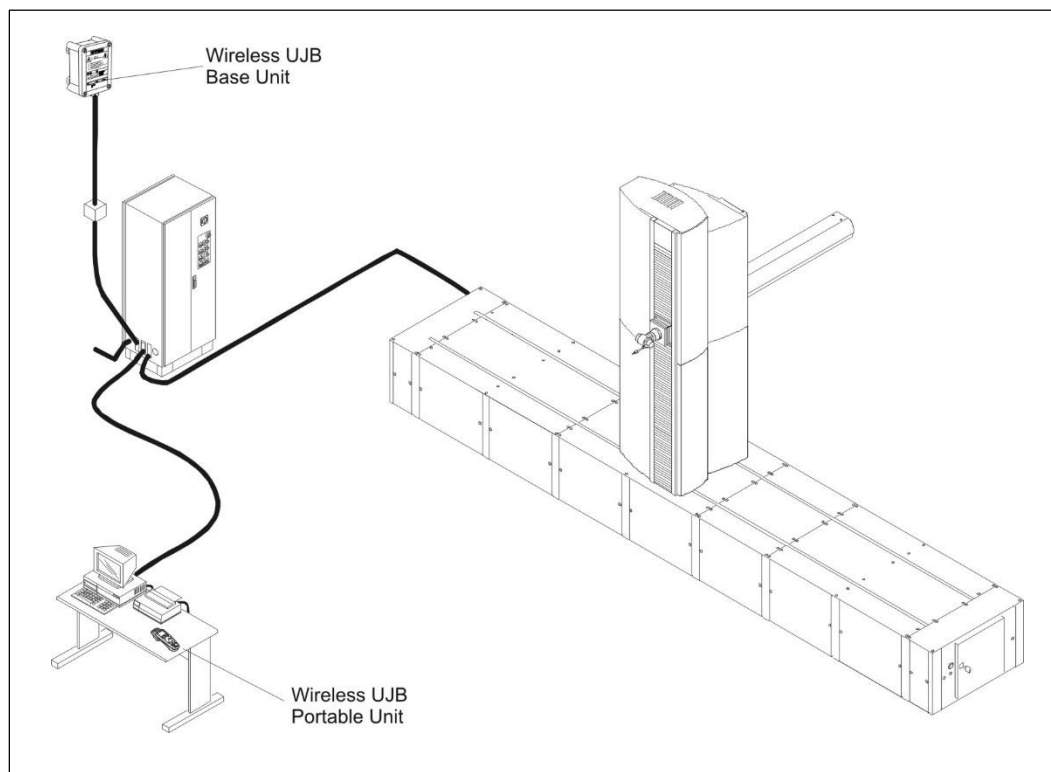

Figure 1 UJB Kit



## Theory of operation

The following figure shows the physical and logical connections between the Portable Unit and the Base Unit of the UJB Kit and between Base Unit and control system.

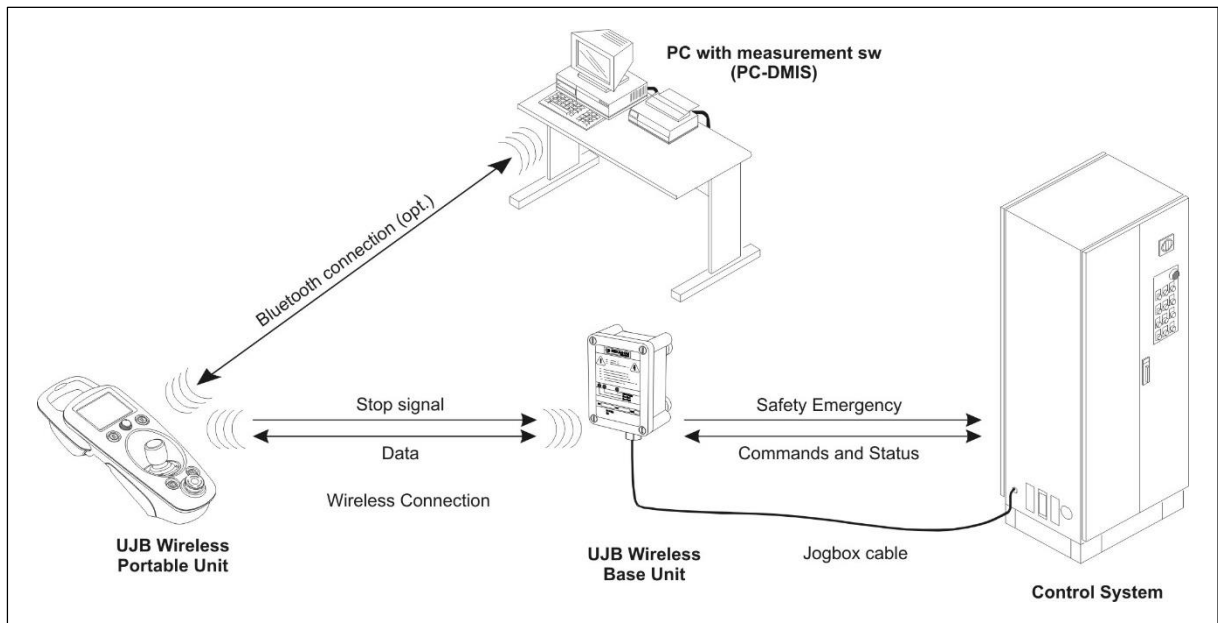

Figure 2 UJB Kit interconnections

The transmission protocol specifically designed and developed for the UJB Kit allows transmitting with a high degree of safety, and on a single radio channel, both the condition of the STOP pushbutton (pressed/released) and the user's commands issued by means of the Portable Unit's joystick, buttons and touch-screen.

The same single, bi-directional, half-duplex radio channel transmits to the Portable Unit's touch-screen the control system's feedback relatively to the issued commands.

The transmission of a safety code univocal to each UJB Kit guarantees that the radio communication between Portable and Base Unit is not affected by interferences coming from other wireless devices in the same frequency range.

The Base Unit converts the data received from the Portable Unit and sends it, through the interconnection cable, to the Control System. In practice, the Base Unit is perceived by the control system as a standard UJB.

As soon as the Base Unit receives the STOP signal generated by the pressure of the STOP pushbutton on the Portable Unit, it disables its own safety relays and makes the control system enter a safety emergency condition. Immediately, the control system stops the arm, i.e. cuts the power supply to the driving gear causing the immediate stop of the measuring system and of its moving parts (for further details about the management of anomaly and emergency conditions, please refer to the User's Manual of the control system).

The Base Unit continues keeping the control system into the safety emergency condition until it receives the signal that the user has restored both the data transmission and the STOP pushbutton.

The Base Unit generates a safety emergency condition also when the radio channel becomes unavailable for any reason (e.g. low battery, Portable Unit shutdown, a hardware malfunction, an interference on the radio channel, exceeding the allowable distance or poor signal quality).

The Base Unit also converts and sends through the radio connection the information addressed to the Portable Unit that is generated by the control system.

# UJB Kit composition

The UJB kit is made up of the following devices:

- UJB Base Unit (A): connected to the Controller by means of a 3 m long cable and to the UJB Wireless Portable Unit by radio frequency, it connects the Portable Unit to the Controller.
- UJB Wireless Portable Unit (B): a portable device of the Hexagon Metrology (HexMet) measuring systems that allows performing many operations while standing close to the CMM (Coordinate Measuring Machine).
- UJB Wireless Docking Station (C): this pedestal allows accommodating the Portable Unit when not in use while at the same time recharging it.
- UJB Wireless AC/DC Power Supply (D): this power supply may be connected either to the Portable Unit or to the Docking Station, according to the user's requirements.



Figure 3 UJB Kit composition

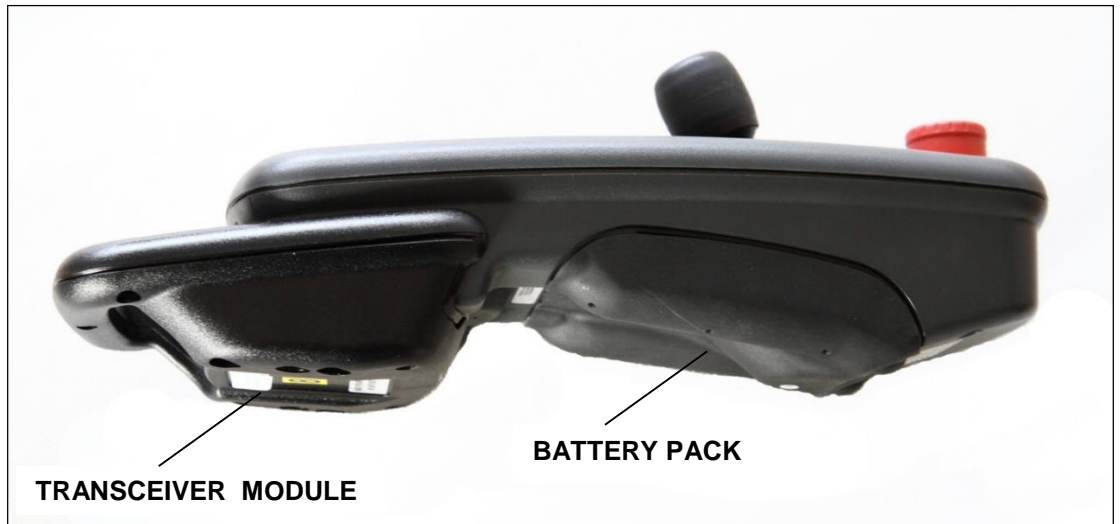

Figure 4 UJB Portable Unit side view

## Technical Data

### General Characteristics

Wireless range (with no obstacles)	40 m
UJB Kit operating temperature range	+5°C ÷ +40°C (41°F ÷ 104°F)
Relative Humidity	50% ÷ 90% non-condensing
Altitude	Up to 1000 m above sea level

### Wireless communication characteristics

Operating frequency ranges	869.700 ÷ 869.975 MHz (European version) 902.75 ÷ 923.65 MHz (USA version)
Output power	+ 5dBm max. 869.700 ÷ 869.975 MHz (European version) -1dBm max. 902.75 ÷ 923.65 MHz (USA version)
Modulation	GFSK
Channels	12
Channel spacing	25 KHz (European version) 1.9 MHz (USA version)
Hamming distance	≥ 4

### UJB Wireless Portable Unit characteristics

Power supply	Battery pack: 7.2 V, 2600 mAh External power supply by means of AC/DC Adapter: 12Vdc, 750 mA max See the details in "Battery Pack technical data" on page 41 and in "AC/DC Adapter technical data" on page 43.
Autonomy (typical use)	9 ½ ÷ 10 hours
External power supply and inserted battery recharge	By means of Docking Station power by the AC/DC Adapter or By means of AC/DC Adapter direct connection to Portable Unit See the details in "Charging the Battery Pack" on page 38.

Weight	1.05 Kg (with battery pack)
External dimensions (LxDxH)	130 x 340 x 120 mm (including joystick)
Layout and functions	See the "Instructions for use" chapter from page 9.
Degrees of protection	IP41
Antenna	¼ wave, internal

### UJB Wireless Base Unit characteristics

Power supply (provided by the Control System)	5 V=, 0.15A 24 V=, 0.1 A
Weight	1,3 Kg (including cable)
External dimensions (LxDxH)	110 x 74 x 155 mm (excluding cable grommet)
Degrees of protection	IP54
Antenna	¼ wave, internal

### Bluetooth radio module characteristics (optional)

Technology	Standard Bluetooth
Frequency range	2.402 ÷ 2.480 GHz (ISM band)
Output power	Class 1 +17 dBm
Approvals	R&TTE (Europe), FCC/CFR 47 part 15 unlicensed
FCC ID IC	PVH090103S 5325A-090103S

---

## Compliance to standards

### Directives and safety standards

The UJB Kit complies with the directives listed below.

Directive	Description
Directive 99/05 CE	R&TTE Directive
Directive 2004/108 CE	Electromagnetic Compatibility Directive
Directive 2006/42 CE	Machines Directive
Directive 2006/95 CE	Low Voltage Directive

The UJB Kit complies with the safety standards listed below:

Safety Standard	Description
EN60204-1: 2006	Safety of machinery – Machine electrical equipment § 9.2.7 Cableless control
ISO13849-1	Safety of machinery – Safety-related parts of control systems: PL=d for STOP function PL=b for Enable function

Conformity to the ISO 13849-1 rule has been certified by the TÜV-SUD organization, certificate n.....

## FCC (Federal Communications Commission)

The UJB Kit complies with the limits stated by part 15 of the CFR 47 rule for unlicensed devices.

FCC ID: OYWG596266	Portable Unit
FCC ID: OYWG596611	Base Unit

### ***FCC Declaration***

Changes or modifications to the UJB Kit that are not expressly approved by the responsible party for compliance could may void the user's authority to operate this equipment.

---

**Note:** this equipment has been tested and found to comply with the limits for a Class B digital device, pursuant to Part 15 of the FCC Rules. These limits are designed to provide reasonable protection against harmful interference in a residential installation. This equipment generates, uses and can radiate radio frequency energy and, if not installed and used in accordance with the instructions, may cause harmful interference to radio communications. However, there is no guarantee that interference will not occur in a particular installation. If this equipment does cause harmful interference to radio or television reception, which can be determined by turning the equipment off and on, the user is encouraged to try to correct the interference by one or more of the following measures:

- Reorient or relocate the receiving antenna
  - Increase the separation between the equipment and receiver
  - Connect the equipment into an outlet on a circuit different from that to which the receiver is connected
  - Consult the dealer or an experienced radio/television technician for help
- 

## IC (Industry Canada)

The UJB Kit complies with the limits of the Radio Standard Specification RSS-210-(2010) rule.

IC: 10123BG596266	Portable Unit
IC: 10123BG596611	Base Unit

---

## UJB Kit installation and maintenance

Users of the UJB Kit are only allowed to perform the ordinary maintenance operations described in this document.

The UJB Kit's installation and extraordinary maintenance operations must be performed by Hexagon Metrology's service personnel or by qualified personnel expressly authorized by Hexagon Metrology.

If the Portable Unit or the Base Unit have to be repaired at the Hexagon Metrology's facilities, always send both devices, even if only one of them is not working.

Therefore you are advised to keep the UJB Kit's packaging in a suitable location.

## External Host Interface

The Portable Unit, in addition to the main radio module, features also a second radio module (see the figure of the previous page) for communicating with a PC hosting a measurement software such as PC-DMIS. The PC-side radio connection is assured by an optional USB Bluetooth Dongle.

In this way the Portable Unit becomes a PC-DMIS' External Host Interface providing the main functions employed during a part-program self-learning procedure.

The UJB External Host Interface provides to measurement software such as PC-DMIS a way to communicate directly with a UJB via touches and graphics drawn directly on the UJB's touch-screen. This interface provides virtually limitless possibility for the measurement software and CMM operator to interact.

### Overview

The UJB External Host Interface uses a wireless Bluetooth connection to talk directly to the host PC running the measurement software, PC-DMIS.

There are 2 basic areas of the UJB where the operator can view graphics from the external host (see the figure below):



- The banner area at the top of the page: this can be viewed on most operational pages (banner is not viewable in service page areas)
- The dedicated external host page. The operator can access the external host page in two ways: touching the banner or using the External Host Interface button on the main page. From the External Host full page the operator can press the home button and it will always return to the page he was previously on.

---

**NOTE:** for any additional information about using PC-DMIS with the Portable Unit, please refer to the PC-DMIS software documentation.

---

# Instructions for use

This chapter contains the procedures and information needed for a correct and efficient use of the UJB Kit.

---

## Safety precautions for the use of the UJB Kit

Given that the UJB Wireless device appears to the system as a normal cabled UJB, during its use you must observe all the relative precautions specified in the following documents:

- User's Manuals of the utilized measuring system components (typically, measuring machine, control system and measuring software)
- Specific manuals relative to the installation and the application (if present).

In particular, it is necessary to strictly observe the following safety rules:

- Always remain within direct sight of the measuring machine's movements commanded by means of the UJB Wireless and follow them carefully.
- Before starting to use the UJB Wireless Portable Unit always check the operation of the STOP button. If it does not work or does not cause the expected emergency conditions, do not use the Portable Unit.
- Only switch on or operate the UJB Wireless Portable Unit to perform conscious and desired operations. An improper use of the Portable Unit could cause dangerous situations.
- Immediately intervene by pressing the STOP button whenever a dangerous situation occurs.
- Check the entire work area and intervene by pressing the STOP button whenever a dangerous situation occurs.
- Take care that no material such as dust or particles that could cause Portable Unit faults or compromise its safe operation are deposited on its surface.
- In case of malfunction, damaged parts or faults, switch off and do not use the UJB Wireless until the problem has not been solved or removed.
- If more than one UJB Wireless device is present in the same work area, take care of placing each Portable Unit in such a way that it is manifest to what measuring machine it is associated. In order to easily identify the correspondence between Portable Unit and measuring machine, at installation time two identical labels have been applied to the Portable Unit and to the measuring machine.



## Commands and signals of the Portable Unit

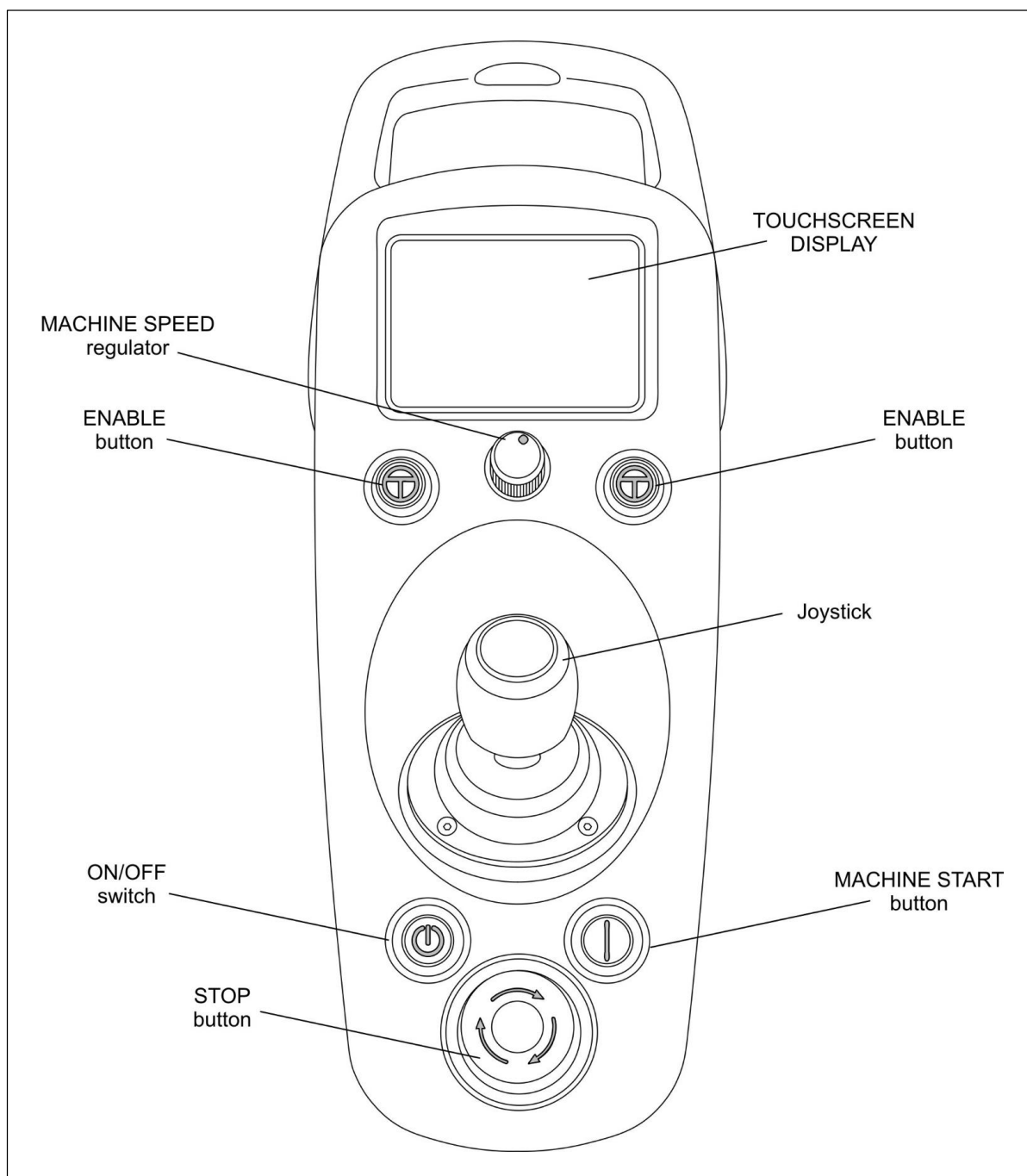



Figure 5 UJB Portable Unit front view

The controls available on the UJB Wireless Portable Unit are identical to those of the standard UJB with the addition of some specific controls/signals for the battery and wireless connection management.

# Unit Operation

Once you have completed the installation and powered up the system, the UJB will complete a boot cycle.

Once the controller completes its boot cycle the X, Y and Z icons on the main screen will change from grey to green. You will then be in a position to begin normal machine operation.

Press the machine start button  located in the lower right quadrant of the UJB.

Depress the right or left enable buttons  located in the center of the UJB to jog the machine with your joystick.

The UJB comes with a touch screen display for ease of operation. Depressing the touch screen icons will issue commands to the controller initiating an action. When a touch screen icon is pressed the icon will temporarily change to a halftone colour indicating contact to the screen has been made. A ‘blip’ will also be heard. The purpose of the halftone is to provide feedback to the operator that a touch has been registered with the system for action and prevent a user from mistakenly touching the input screen a second time and reversing the intended action.

The icon will change to a green state when the function is active; green icons indicate the function is active or “On” while grey icons indicate the function is inactive or “Off”.

When powered up the touch screen will enter the Main Screen, also referred to as the “Normal Machine Control” page (see the “Icon Cross Reference (Normal Machine Control Page)” paragraph of page 14). Pressing the Home icon will immediately take you to the Home page (see the figure below).

The touch screen display is divided into three sections (the Home Page is displayed):

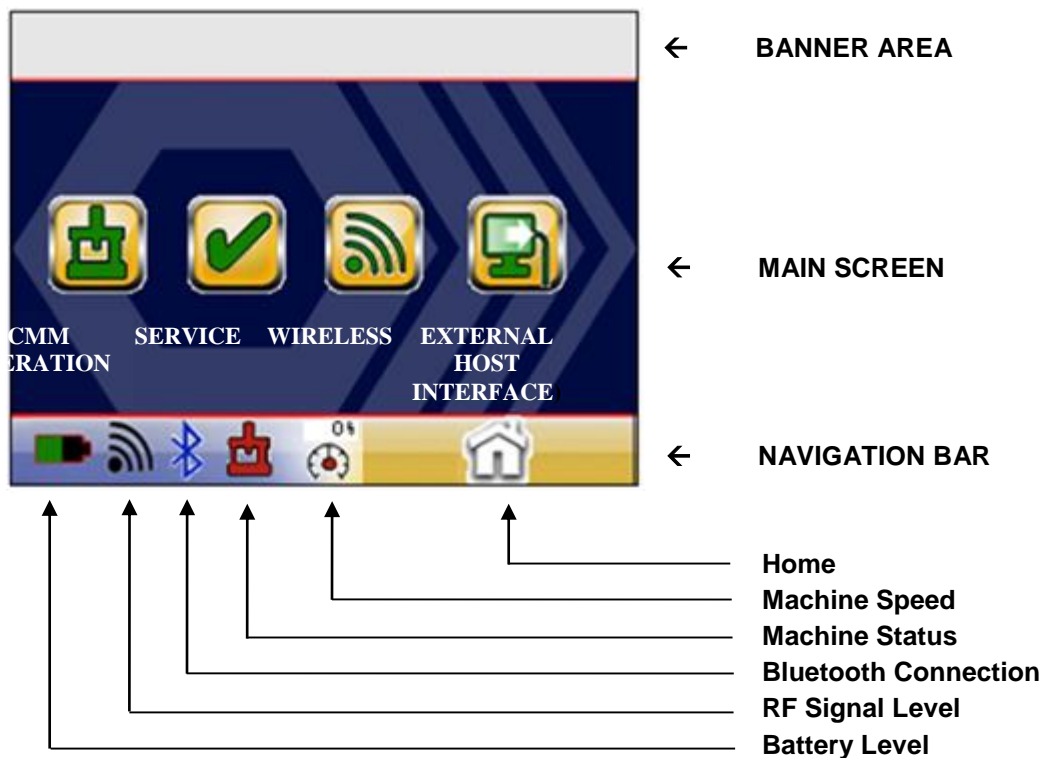

- The upper banner which when pressed will take the operator to an “External Host page”.
- Main screen icons which contain the active icon set to operate your CMM.

- The navigation bar which allows the operator to select modes of operation from the home page or move from page to page. The navigation bar also presents status indicators based on the mode the operator has selected.

To operate your CMM the operator will be working primarily within the main screen section. The information provided in the table of the following page should answer any questions you may have and help familiarize you with the symbology that has been selected for CMM operation.

For a complete listing and description of every Icon mentioned in this device please refer to the “UJB Quick Reference Guide” at the end of this document (page 45).







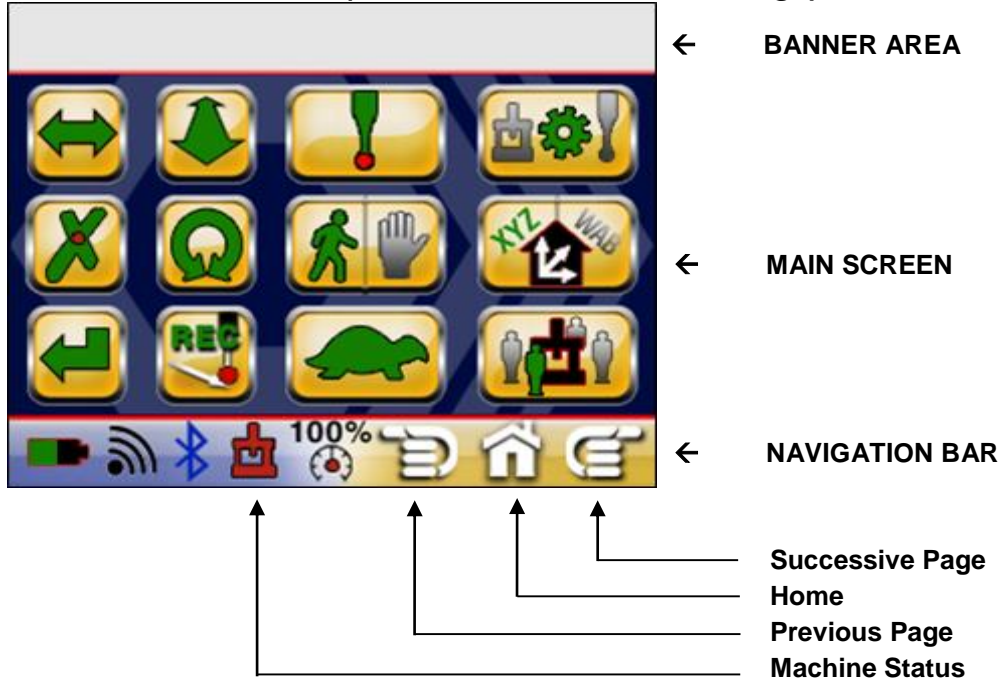





### ***Touch screen general information***

- Machine Start Values:
  - Green = ON
  - Grey = OFF.
- Machine status indicator flashing Red/Yellow = no Mobile to Base communication.
- Pressing the Home Icon in the navigation bar of the Home page or External Host Interface page will return you to your previous screen.
- Pressing the Home Icon in the navigation bar of the Main page will return you to the Home page.
- The Icons noted on this page may vary depending on your machine type and system mode.
- Battery Level indicates how much life is left in your battery.
- RF Signal Level indicates the signal strength received from mobile unit.
- Bluetooth Connection indicator shows the status of the Bluetooth link.  
Blue = Connection Up, Black = Connection Down (only available when installed).
- Machine Speed indicates the maximum percentage of speed that the machine will run at (only available for controllers supporting speed control from the UJB).
- The display does not support multi press operation at this time.
- Should you find a multi key function missing from the menu please contact your service representative for assistance.

### Icon Cross Reference (Normal Machine Control Page)



SYMBOL	DESCRIPTION	LEGACY ICON
	DONE	
	X JOYSTICK AXIS ENABLE Green = ON / Grey = OFF	
	Y JOYSTICK AXIS ENABLE Green = ON / Grey = OFF	
	Z JOYSTICK AXIS ENABLE Green = ON / Grey = OFF	
	JOG MODE	
	RECORD/MOVE POINT	
	LOCK	
	UNLOCK	





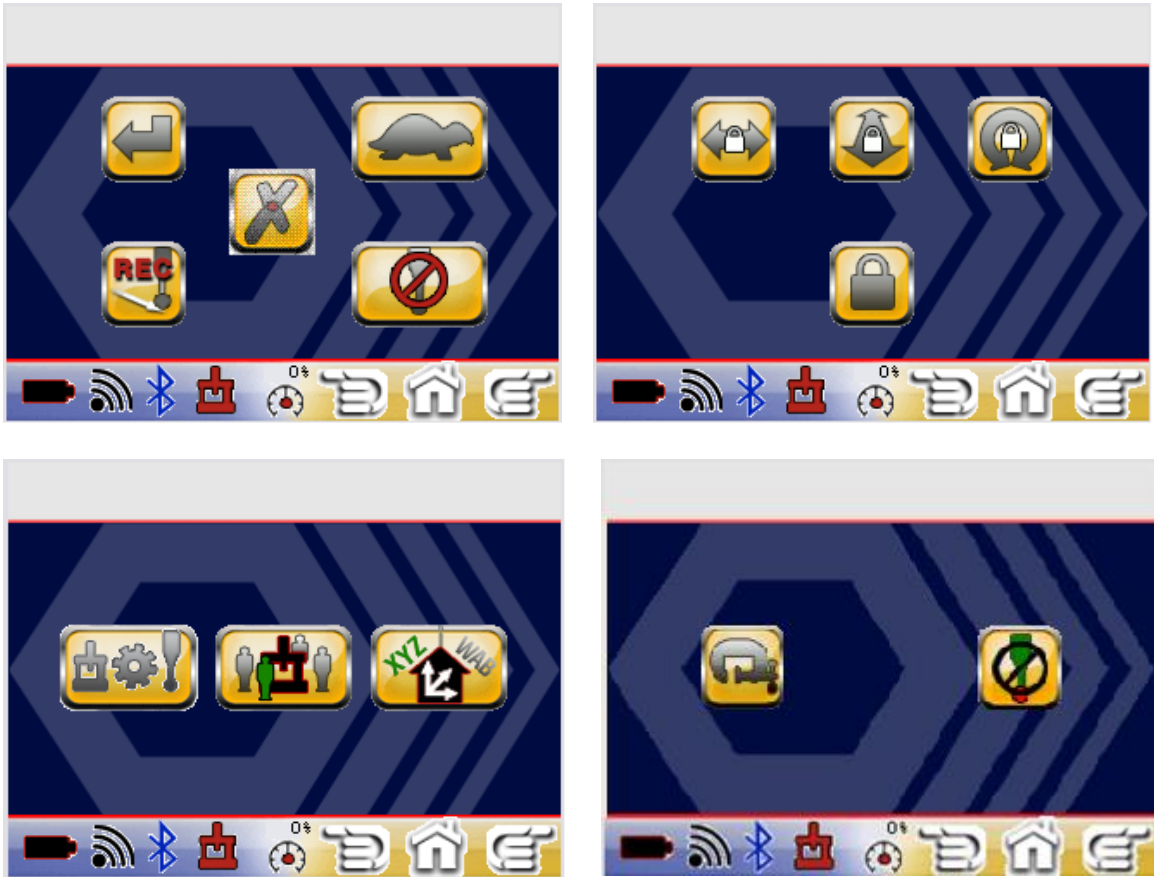

	<b>OPERATOR POSITION</b>	N/A
	<b>SLOW MODE</b> Green = SLOW / Grey = FAST	
	<b>RUN/HOLD</b>	
	<b>PROBE ENABLE</b>	
	<b>DELETE POINT</b>	
	<b>SHIFT</b>	
	<b>MACHINE STATUS</b> Flashing red/yellow = BOOTING UP Grey = BOOT COMPLETED Green = DRIVES ON Red = NO LINK	

## CMM Gloved Operation Screens

The gloved operation screens present the CMM movements control icons in a pattern that makes easier to select them when wearing gloves. These pages are displayed by pressing the “Successive Page” icon in the Normal Machine Control Page (and then scrolling them with the “Successive/previous Page” icons).



### Icon Cross Reference (Probe Function Screen)

SYMBOL	DESCRIPTION	LEGACY ICON
	CLAMPING	
	PROBE ENABLE Green = ON / Grey = OFF	
	PROBE PRESSURE	N/A
	BALANCE	N/A

# Touch Screen Functionality Reference

The Home page (see below) allows the operator selecting one of several functional categories. These categories have several pages of features which can be accessed if the category and features are supported.

The top part of the screen, referred to as the upper banner, functions as the access button to the External Host Interface and can be used to present brief operator prompts or positional data.

The bottom row of icons is the navigation bar and will appear on all pages. This allows the operator to move from page to page within any given loop or feature category to access the menu pages. The operator can move left or right within the category by pressing the left or right arrow.

## Home Menu

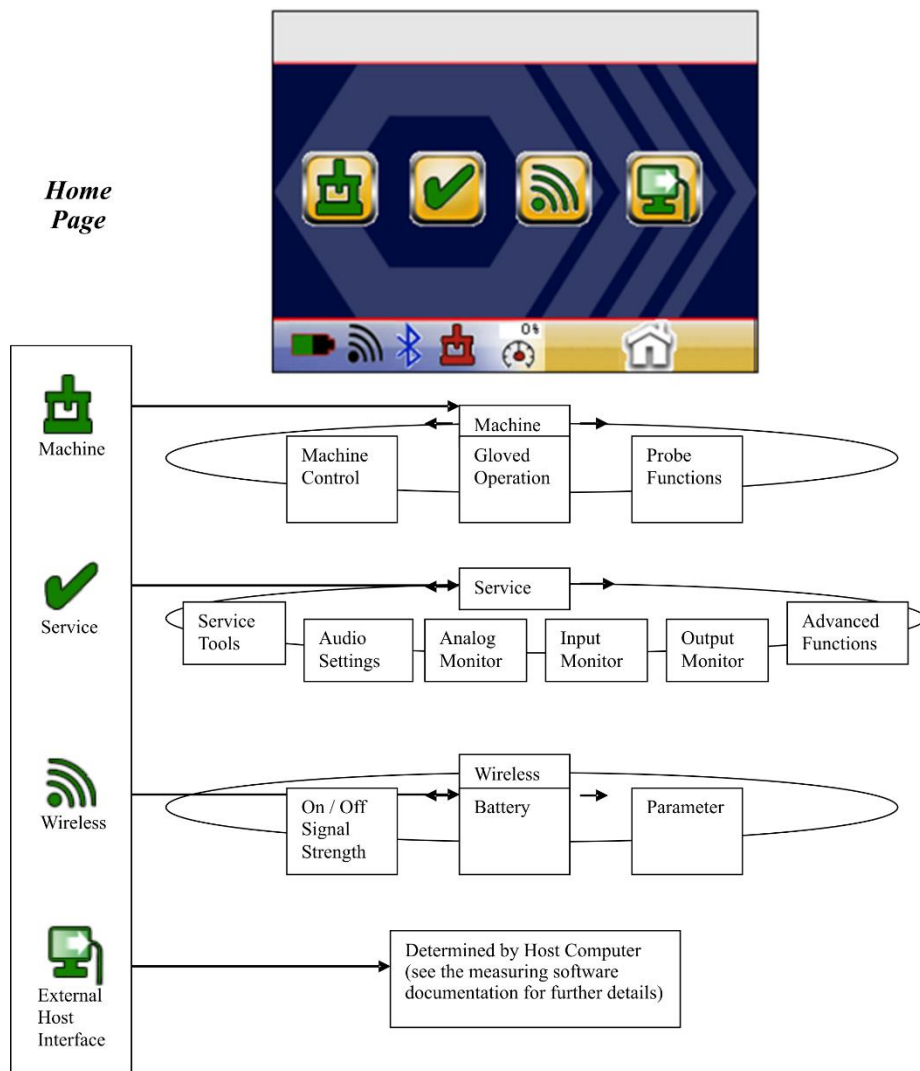

---

# UJB Wireless Portable Unit Use Instructions

## Switching ON/OFF the unit

Switch on/off the UJB Wireless Portable Unit using the ON/OFF button (see Figure 5 of page 11).

---

**Note:** the Portable Unit will start operating only after the arm will have been correctly started. While starting the arm, always remember to first switch on the Portable Unit and then the control system.

---

The procedure for starting the UJB Wireless Portable Unit while starting the arm is as follows:

1. If depressed, release the STOP button.
2. Press and hold the ON/OFF switch for a few seconds.
3. Switch on the control system.
4. If the Portable Unit and the control system have been correctly started, the UJB Wireless (after 50-80 seconds) will be synchronized and will display the following indications:
  - a. The Wireless Level icon becomes red indicating the signal level received by the Portable Unit.
  - b. The Machine Status icon goes from blinking in yellow/red colors to grey.
  - c. Some of the Normal Machine Control Page's icons are switched off (initially all icons are on).
5. If needed, you can now press the Machine Start button to power on the machine axes.

If the STOP button is pressed, the radio communication between Portable and Base Unit is interrupted: this will evidently cause the interruption of the dialogue with the control system.

When the STOP button is released, after a few seconds, the communication with the Base Unit (and the control system) will be synchronized again and the Portable Unit will be operative again.

---

**Note:** if, at the first start, the UJB Wireless Portable Unit is switched on AFTER the control system, a functional emergency condition will be generated and the user will see the "JOGBOX FAULT" signalization. In order to restore this emergency, switch off the control system and repeat the procedure described above.

---

For further information about the arm start procedures and the emergency recovery, please refer to the User's Manual of the utilized control system.



---

# UJB Wireless Portable Unit Command Reference

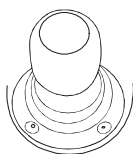

## Joystick

The joystick is used to move one or more of the X, Y and Z axes of the measuring machine at a desired speed. The joystick can be deflected to the left or right, forwards or backwards, and turned clockwise or anticlockwise. These movements can be combined with one another.

Only the X, Y and Z linear axes may be moved using the joystick. The status of the icon on each **X JOYSTICK AXIS ENABLE**, **Y JOYSTICK AXIS ENABLE**, **Z JOYSTICK AXIS ENABLE** UJB touchscreen button indicates which axis is enabled for movement (grey icon = axis disabled; steady green icon = axis enabled).

The movements of the X, Y and Z machine axes are controlled from the UJB, and are made at the speed set using the knob situated on the UJB. The maximum speed at which axes may be moved depends on the status of the **SLOW MODE** icon.

Which axis moves, and in what direction, following each movement of the joystick, depends on the reference system in use on the measuring machine and the status of the **OPERATOR POSITION** button. For further details, see “Moving the Machine Axes from the Portable Unit” on page 22.

To sum up, the axis movements controlled from the UJB are only made if all the conditions listed below are satisfied:

- No axis is moving when the movement is activated.
- The **ENABLE** button is held pressed while moving the joystick.
- The icons of the touchscreen buttons that refer to the axes to be moved (**X JOYSTICK AXIS ENABLE**, **Y JOYSTICK AXIS ENABLE** and **Z JOYSTICK AXIS ENABLE** buttons) are steady green.
- The speed set on the UJB is not zero.
- The control system is in the Run status.

## STOP Pushbutton

When this pushbutton is pressed, a safety emergency condition is generated. See “Managing an Emergency Condition” on page 23 for further details.

## ENABLE

The **ENABLE** button must be kept pressed when the UJB is used to move the axes. If the joystick is moved without holding this button pressed, the axes will not move (this prevents unwanted accidental movement of machine axes).

## MACHINE START

The **MACHINE START** button turns on the power supply for the axis drives, thus enabling machine axes to be moved from the Part Program or the UJB.

To turn on the power supply for the drives, hold the button pressed for at least two seconds. The drives are only supplied if there are no pending emergency conditions.

The **Machine Status** indicator on the touchscreen shows the current setting:

- Indicator off. The drives of the axes are not powered (for example, due to an emergency). Default setting when the control system is started up.
- Indicator green. The drives of the axes are powered.

If the **START** button is not present on the control panel of the control system, the **MACHINE START** button is always enabled. If the **START** button is present on the control panel, the **MACHINE START** button is only enabled when the control system is in Manual status (when the control system is in Automatic status, use the **START** button on the control panel of the control system).

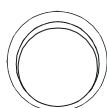



### ON/OFF

This **ON/OFF** button is used to switch on/off the Portable Unit. The unit does not switch off automatically, therefore always remember to switch it off when not in use, to prevent a complete discharge of the battery. See also the details on the battery charge (Charging the Battery Pack, page 38).

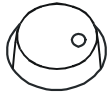

### MACHINE SPEED

This knob is used to set the speed of movement of the machine axes. By turning the knob, the speed can be set to any value between zero (the machine axes remain still) and the allowed maximum speed (which depends on the status of the control system and the setting made using the **SLOW MODE** touchscreen button).

The **Machine Speed** indicator on the touchscreen shows the value currently applied as the percentage of the allowed maximum speed.

---

**Note.** If the speed regulator is set to the minimum value (zero), the axes of the measuring machine will not move. For example, the regulator must be set to an appropriate speed before the machine axis homing procedure is started.

---



### X JOYSTICK AXIS ENABLE



### Y JOYSTICK AXIS ENABLE



### Z JOYSTICK AXIS ENABLE

Each of these buttons starts or stops the movement of the corresponding axis using the UJB. The colour of the icon of the button indicates the current setting:

- Green icon. The corresponding axis can be moved using the joystick. When the control system is started, all three icons are green.
- Grey icon. The corresponding axis cannot be moved using the joystick.



### DELETE POINT

The **DELETE POINT** button is used to respond to requests coming from the software. Its function therefore depends on the software in use.



### DONE

The **DONE** touchscreen button is used to respond to requests coming from the software. Its function therefore depends on the software in use.



### JOG MODE

Touchscreen button. Not used.



### LOCK/UNLOCK

Touchscreen button. Not used.



### RECORD MOVE - POINT

The **RECORD MOVE - POINT** touchscreen button is used to respond to requests coming from the software. Its function therefore depends on the software in use.



### PROBE ENABLE

The **PROBE ENABLE** touchscreen button only has effect during probe movement using the UJB.

The colour of the icon on the **PROBE ENABLE** button indicates the current setting:

- Grey icon. When the probe touches an object, the axis movements are not stopped (the contact inside the probe is always kept open).
- Green icon. When the probe touches an object during a movement or point picking operation, the axis movements are stopped. This is the normal method of using a probe.

---

### CAUTION

*When the icon of the **PROBE ENABLE** button is grey, the control system cannot detect any collision or contact between the probe and any object; great care must therefore be taken when moving the probe.*



---



## RUN/HOLD

The **RUN/HOLD** touchscreen button switches the control system from Run to Hold and vice versa.

The colour of the icons on the **RUN/HOLD** button indicates the current setting:

-  icon on red. The control system is in Hold.
-  icon on green. The control system is in Run. Default setting at control system start-up.

The **RUN/HOLD** button may always be used to switch from Run to Hold.

If the control panel has the **RUN** and **HOLD** buttons, the **RUN/HOLD** button will only switch from Hold to Run when the control system is in Manual status (to switch from Hold to Run when the control system is in Automatic status, use the **RUN** button on the control panel).

The **RUN/HOLD** button has the same function as the **RUN** and **HOLD** buttons on the control panel (if present).



## SHIFT

The **SHIFT** touchscreen button allows selecting which set of axes the joystick will control: the choice is between the main set of three axes (default) and the additional set of axes, typically those of the continuous wrist.



## SLOW MODE

The **SLOW MODE** touchscreen button sets the maximum speed for machine axes while their movement is controlled from the UJB. Two values may be chosen (*fastJogVel* and *slowJogVel*, with *fastJogVel* > *slowJogVel*), are configured on the control system and vary according to the type of measuring machine in use.

When the control system is in Manual status, the maximum speed of the machine axes is set to the lower value between the one selected using the **SLOW MODE** button and the *manualVel* setup parameter. (The *manualVel* setup parameter specifies the maximum speed at which the linear axes of the measuring machine can be moved using the joystick or Part Program when the control system is in Manual status).

The colour of the icon in the **SLOW MODE** button indicates the current setting:

- Grey icon. The maximum speed is *fastJogVel* (or *manualVel* as described above).
- Green icon. The maximum speed is *slowJogVel*. Default setting at control system start-up (or *manualVel* as described above).

---

**Important Note.** The measuring performance and operation of the measuring machine in use are only guaranteed if the maximum speed is set to *slowJogVel* (and the icon of the **PROBE ENABLE** button is green). When the axes are moved from the joystick using *fastJogVel* (icon gray), to prevent problems caused by false triggering, we recommend you select “gray icon” condition on the **PROBE ENABLE** touchscreen button.

---



## OPERATOR POSITION

The **OPERATOR POSITION** touchscreen button is used to reconfigure the movements of the joystick according to the position of the user with respect to the measuring machine. The status of the **OPERATOR POSITION** icon influences the mapping of the joystick movements that cause the X and Y axes to move.

For further details, see “Moving the Machine Axes from the Portable Unit” on page 22.

## Moving the Machine Axes from the Portable Unit

**Note.** The information given in this section is valid when the measuring machine is configured with the Hexagon Metrology standard reference system (commonly adopted in most applications). If another reference system is being used, this information is to be interpreted in accordance with the actual configuration.



The figure below shows an example that indicates where the user should be positioned with respect to the measuring machine when the icon of the **OPERATOR POSITION** touchscreen button is set as shown to the left. In this case, moving the joystick forwards (backwards) causes a movement in the +X (-X) direction, when moving the joystick to the right (left), the movement is made in the -Y (+Y) direction.

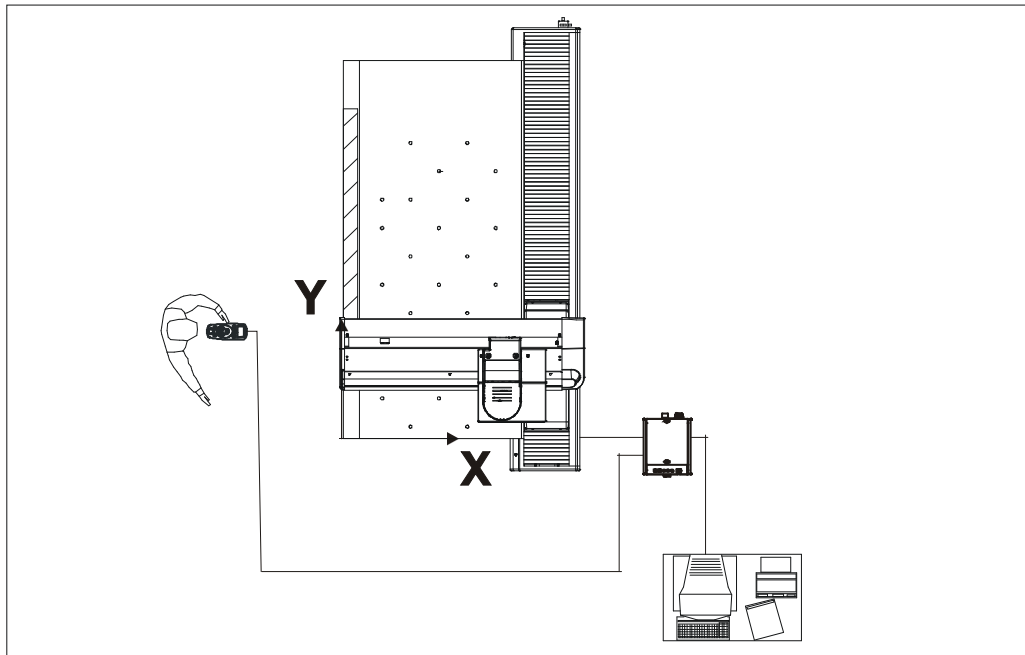

On the basis of the conventions indicated above, each joystick movement moves the corresponding machine axis as indicated in the table below.

OPERATOR POSITION Icon	User Position	Joystick Movement	Axis Movement
	In front of the CMM	Shift Right/Left	+X/-X translation
		Shift Forwards/Backwards	+Y/-Y translation
		Turn Clockwise/Anticlockwise	-Z/+Z translation
	Behind the CMM	Shift Right/Left	-X/+X translation
		Shift Forwards/Backwards	-Y/+Y translation
		Turn Clockwise/Anticlockwise	-Z/+Z translation
	To the right of the CMM	Shift Right/Left	+Y/-Y translation
		Shift Forwards/Backwards	-X/+X translation
		Turn Clockwise/Anticlockwise	-Z/+Z translation
	To the left of the CMM	Shift Right/Left	-Y/+Y translation
		Shift Forwards/Backwards	+X/-X translation
		Turn Clockwise/Anticlockwise	-Z/+Z translation

## Managing an Emergency Condition

When an emergency condition arises, the control system stops the measuring system and signals the emergency condition as follows:

- It turns off the **Machine Status** indicator on the UJB.
- It signals the condition to the software which, if correctly started, displays the relevant information for the user.

To recover an emergency condition, you must first remove its cause (or causes) and then carry out the recovery procedure (note that there may be several emergency conditions pending at the same time).

The measuring system cannot be restarted or reused until all the causes that generated the emergency condition have been removed. If the emergency condition cannot be reset and the arm restarted after all possible causes have been removed, this means that a fatal error has occurred (normally a hardware problem).

### ***How to Recover an Emergency Condition (UJB)***

1. Eliminate the cause (or causes) that generated the emergency condition. If the software has been started, use also the information displayed on the PC screen to identify the causes and take the appropriate corrective action.

2. Reset the emergency condition.

If the control system is in Manual status, press the **MACHINE START** pushbutton on the UJB. If the control system is in Automatic status, press the **START** pushbutton on the control panel (if the **START** pushbutton is not on the control panel, use the **MACHINE START** pushbutton on the UJB).

Keep the button pressed for at least two seconds.

3. Check the status of the **Machine Status** indicator on the UJB. If the indicator is steady green, the arm has started correctly and is ready for use. If it is off, this means that not all causes of an emergency have been eliminated and so the procedure should be repeated from step 1.



# User Service Graphics Reference

The information of this chapter allows setting up various operational parameters of the UJB Wireless and checking the correct operation of its buttons and joystick.

---

# User Service Reference

## Service Screen 1 - Build and Version info

This screen shows specific UJB's firmware content information.

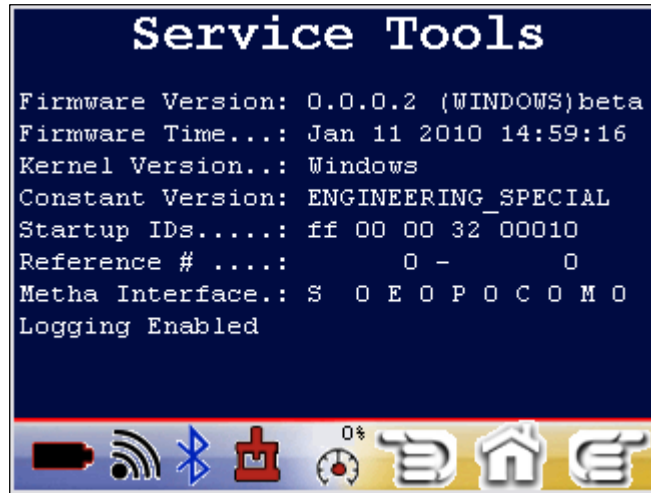

## Service Screen 2 – Audio Settings





## Service Screen 3 – Analog Monitor

This page displays the raw A/D readings for the UJB:

- Joystick X Axis – Raw A/D reading of the joystick X axis
- Joystick Y Axis – Raw A/D reading of the joystick Y axis
- Joystick Z Axis – Raw A/D reading of the joystick Z axis
- Feed Rate – Raw A/D reading of the Feed Rate potentiometer.

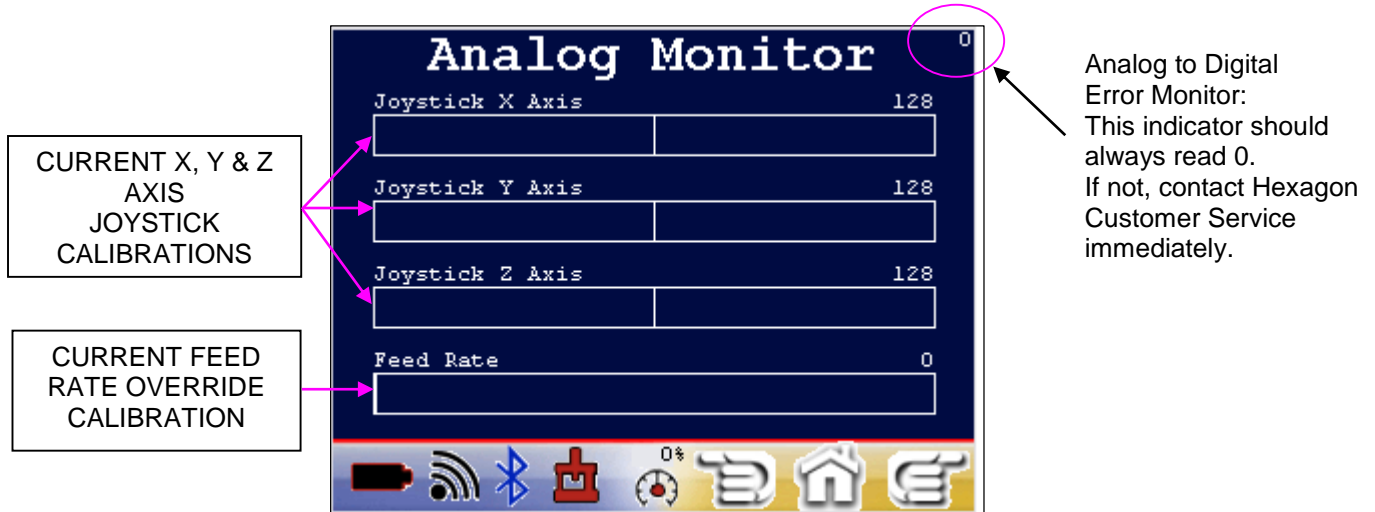

## Service Screen 4 – Input Monitor

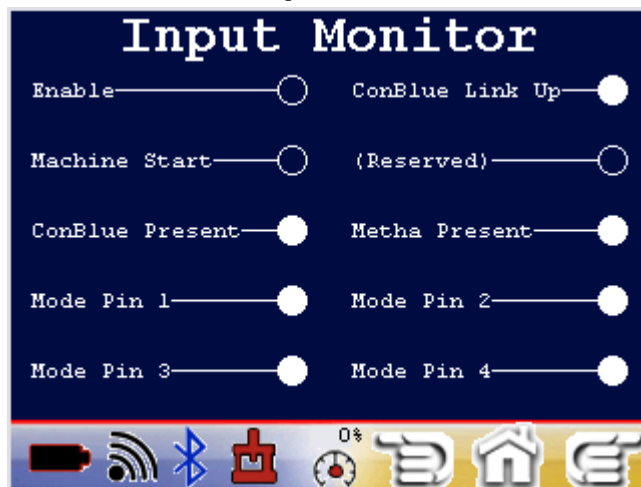

This screen monitors the state of the various inputs to the system: it is for reference only and no change may be performed using it.

The mode pins are driven by the inputs identified below:

- Enable – driven by pressing either the right or left enable button on the UJB (see Figure 5, page 11).
- Machine Start – driven by pressing the machine start button located on lower right quadrant of the UJB (see Figure 5, page 11).
- Mode Pin 1 - 4 – is driven by the cabling scheme. The combined setting of these four input pins defines the machine system configuration under which the UJB will operate.
- ConBlue Present – driven when the Bluetooth module is installed.

- ConBlue Link up – driven when the Bluetooth and PC-DMIS link is established.
- Metha Present – driven when the Metha wireless transceiver is installed.

## Service Screen 5 – Output Monitor

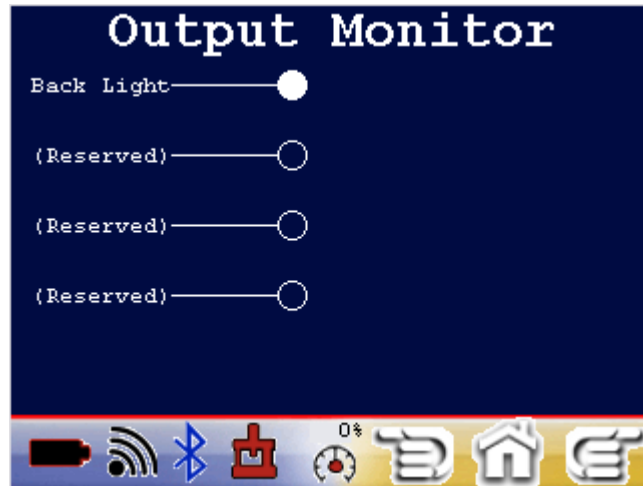

This screen monitors the state of the various outputs of the system: it is for reference only as no change may be performed using it.

- Back Light – drives the backlight of the LCD display.
- (Reserved) – output pins that are reserved for future use.

## Service Screen 6 – Advanced Options

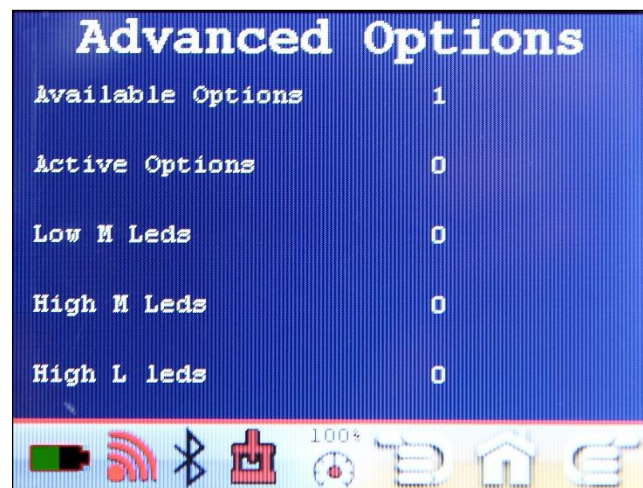

This screen shows the state of some options: it is for reference only as no change may be performed using it.

## Service Screen 7 – Backlight Settings

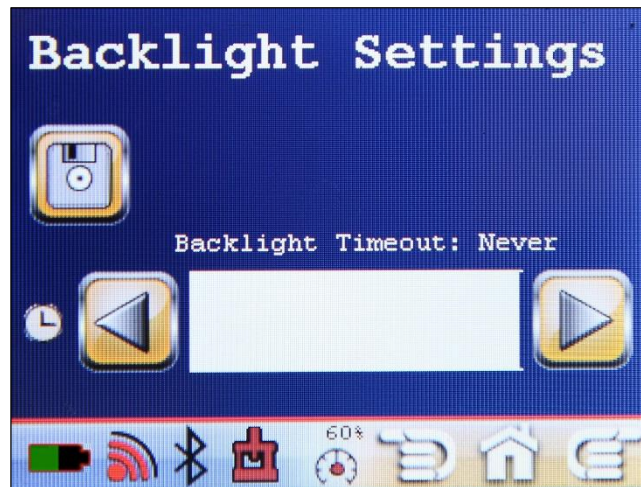

This page allows the user to modify the default timeout values of the LCD backlight.

---

**Note:** settings will immediately take effect even if the operator does not save the values.

---

This screen allows the user to set the backlight timeout by pressing on the two arrows to 10 seconds, 30 seconds, 1 minute, 3 minutes, 5 minutes, 10 minutes, or never. To change the default backlight timeout act on the arrows to select your appropriate timeout value and select the “save” button. Your defaults will be remembered on the next boot cycle.

---

**Note:** any button press or display touch will reset the backlight timer. Joystick movements will not affect the backlight timer.

---



# Advanced Service Graphics Reference

The information of this chapter allows setting up various advanced operational parameters of the UJB Wireless and checking and modifying the operation of its buttons, joystick, touch-screen and audio devices. It also allows performing some tests on the unit.

---

**Caution:** *this section is intended solely for the use of trained Hexagon service personnel. Modifications made to the unit using these service screens may void your warranty.*

---

---

# Advanced Service Reference

---

*Caution: this section is intended solely for the use of trained Hexagon service personnel. Modifications made to the unit using these service screens may void your warranty.*

---

## Service Screen 9 – Advanced Functions



- **Default Settings Editor** – This button will bring you into a series of pages where the user can change some of the internal settings of the system to calibrate the joystick, change the default volume, change the backlight timeout value and system defaults.
- **Rotate Screen 180 Degrees** – This button will rotate the screen and the joystick 180 degrees to operate the UJB in the upside down mode.

---

**Note:** this configuration can be saved as a default by pressing the save button in any of the Advanced Settings pages.

---

- **Screen Calibration** – This button will bring you to a set of pages that are used to verify that the display appears and works properly.

## Tools & Settings Screen 1 – Default Settings Editor



The default settings of the system can be overridden. The factory defaults should be optimal for most situations.

## Tools & Settings Screen 2 – Audio Settings



This page allows you to modify the default volume of the UJB. To change the default settings, adjust the volume, up or down, to the desired level, use the test beep to hear the default volume, then press the “save” button to save the settings. These settings will now be remembered on the next boot cycle.

## Tools & Settings Screen 3 – Backlight Settings



This page allows the user to modify the default timeout values the LCD backlight.

---

**Note:** settings will immediately take effect even if the operator does not save the values.

---

This screen allows the user to set the backlight timeout to 10 seconds, 30 seconds, 1 minute, 3 minutes, 5 minutes, 10 minutes, or always on (infinite). To change the default backlight timeout select your appropriate timeout value and select the “save” button. Your defaults will be remembered on the next boot cycle.

---

**Note:** any button press or display touch will reset the backlight timer. Joystick movement will not affect the backlight timer.

---

## Tools & Settings Screen 4 – Joystick Settings



The factory defaults for the Joystick balance should meet the needs of all users. Should your joystick be damaged or not be properly balanced, use the Joystick Auto Balance feature to reset zero on the UJB.

The Joystick X,Y, and Z values should all be set to 128 +/- 1 if the joystick is not touched (optimal value is indicated by the “Target” field). If the proper target is not being reached the user can press the “balance” button to learn the new zero of the joystick. Once the joystick is balanced, press the “save” button to have the new settings remembered on future boot cycles. At any point the user can return to the factory defaults by pressing the “unbalance” button and pressing the “save” button.



## Tools & Settings Screen 5 – Reference Test



This page is reserved to the service personnel: introducing wrong data could make the Portable Unit unusable and require the intervention of the support service to restore its functionality.

## Tools & Settings Screen 6 – Protocol Settings



This page is reserved to the service personnel: introducing wrong data could make the Portable Unit unusable and require the intervention of the support service to restore its functionality.

## Screen Calibration

The screen calibration function allows the service personnel to verify that the touch screen display appears properly.



# UJB Portable Unit Maintenance

This chapter describes the UJB Portable Unit maintenance procedures.

---

## General

The UJB Portable Unit does not need you to carry out any particular maintenance procedure with the exception of normal care and cleaning.

Pay particular attention to the removal of particles and foreign bodies deposited into the joystick's cup.

---

**Note:** in case of faults or for any advice, please refer to the Hexagon Metrology's Customer Service.

---

## Touch screen and buttons

When necessary, clean using commercially available detergents or water on a soft cloth.

---

## Charging the Battery Pack

The technology of the batteries, the extended battery life and the short recharge times make not necessary replacing the rechargeable battery pack.

The Battery Pack may only be charged by placing the Portable Unit on its Docking Station (see "C" in Figure 3 and the figure below) or by connecting the AC/DC Adapter's plug to the jack connector located next to the Portable Unit's handle, after opening its protective cap (see the figure of the following page). In both cases the AC/DC Adapter provides the energy needed for recharging the battery pack and supplying the Unit's electronic circuits.



Figure 6 AC/DC Adapter plugged into the Docking Station

The supplied batteries have an initial charge of over 80%; in any case, the long-term performance of the batteries may be optimized by carrying out a few complete charge/discharge cycles. Also, in order to guarantee the full battery life from the first utilization, before using the Portable Unit for the first time, completely recharge the battery pack as described above.

You can recharge the lithium-ion polymer battery pack whenever convenient, without requiring a full charge or discharge cycle, without affecting its life-cycle.

The lithium-ion polymer battery pack is protected against full discharge: in case of discharged battery pack, the Portable Unit turns itself off automatically. After this, do not keep trying to switch it on with the ON/OFF button.



Figure 7 AC/DC Adapter plugged into the Portable Unit

The battery pack recharge also occurs when the Portable Unit is off.

The choice of the recharging method (via Docking Station or direct) depends on the type of use:

- If the operator often utilizes the Portable Unit and does it for extended periods of time, it is advisable to place it on the Docking Station when not in use. When placed on the Docking Station, a double beep signals to the operator that the battery charge is started (the battery level icon changes too, see the table of the following page).
- If the operator initiates automatic measuring cycles by means of the control panel and for several days does not use the Portable Unit, then connecting the AC/DC Adapter directly to the Portable is appropriate.

The Battery Pack recharge current is managed automatically: therefore, leaving the Portable Unit connected to the AC/DC Adapter continuously does not damage the battery pack. When the battery pack is fully charged, the recharge current is reduced to almost zero and therefore any stress to batteries is prevented.







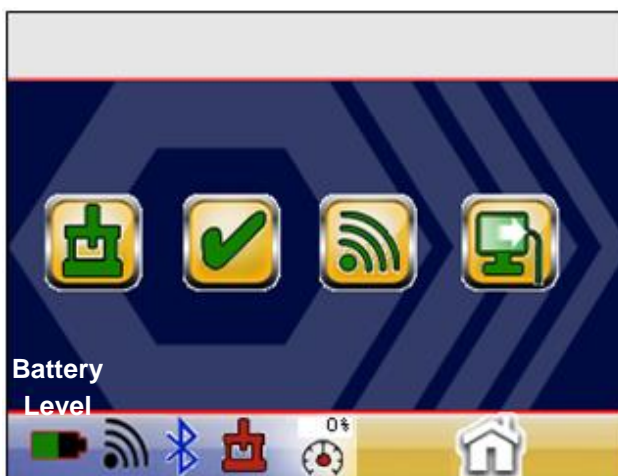

A completely discharged Battery Pack is fully charged in 3 hours (typical): anyway, about 1 hour is sufficient for the batteries to reach a charge level equal to 60-70% of full charge.

The battery life is around 9-10 hours of continuous operation with the display backlight always on.

The touch screen display shows the “Battery Level” in the lower part.



The battery icon provides the following battery charge and status information:

								
100% Charge	75% Charge	50% Charge	25% Charge	10% Charge	< 10% Charge	Alarm	Battery status error	Re-charging

When the battery life is reduced to about one hour, in addition to the 10% charge level a repetitive beep signals the condition to the user. To stop this acoustic signal, place the Portable Unit on the Docking Station and wait for a few minutes.

A fully discharged battery left for a long period of time will lose part of its charging capacity: if you are not going to power the UJB for several weeks, fully charge the Battery Pack.

## Inserting the Battery Pack

The following figure shows the battery pack lower/internal side with the connector that must be inserted into the Portable Unit's respective connector.

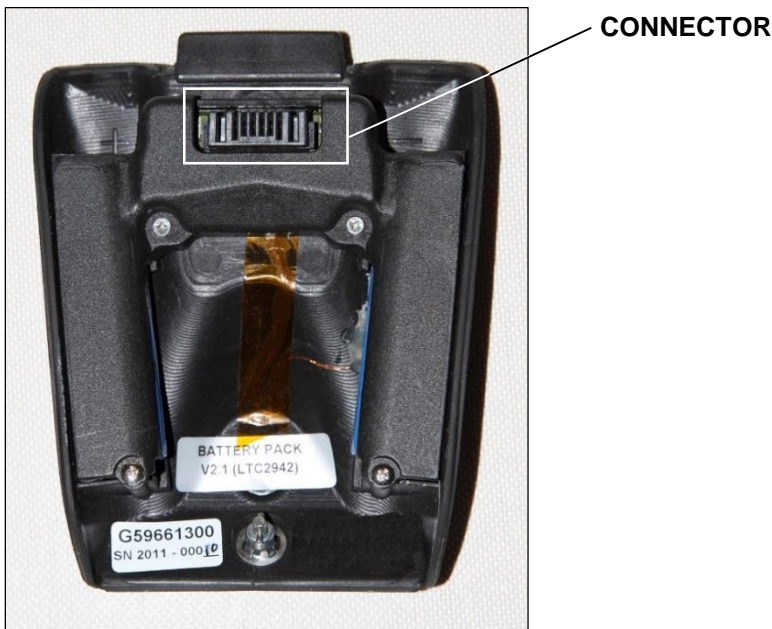

Figure 8 Battery pack



Figure 9 Battery pack in position

Insert the battery pack by first mating its connector with that of the Portable Unit and then pressing down the pack. Fasten the battery pack to the Portable unit by first pressing the clamping screw and then tightening it, one-half turn (clockwise).

## Battery pack characteristics

To power the Portable Unit use exclusively the rechargeable battery pack which is supplied with the unit. The part code of the battery pack is: **G59661300**.

## Battery Pack technical data

Cell type	Lithium-ion, cylindrical
Output	7.2V $\geq$ 2500 mAh (2 cells in series)
Battery life (typical)	9 ½ ÷ 10 hours of continuative operation
Recharge and operating temperature	+5°C ÷ +45°C (41°F ÷ 113°F)
Storage temperature	-20°C ÷ +55°C (-4°F ÷ 131°F)
Number of recharge cycles	500 cycles (average life)

## Battery pack warnings

- Never use a different AC/DC Adapter from the supplied one. The supplied adapter features several protections safeguarding the correct operation and the safety of the battery pack.
- While operating the Portable Unit, do not disconnect the battery pack from the unit. The battery pack should be disconnected only to replace it in case of fault.
- Do not modify or tamper with the battery pack.
- Do not spill water or other liquids on the battery pack.
- In case of disposal, as for any other exhausted battery, the battery pack must be recycled or disposed of rigorously respecting the recommended environmental protection practices.
- The lithium-ion batteries must be disposed of according to the regulations in force in the country where it is used. Do not dispose of it by throwing it in unsorted waste, in fire or in water.

## Safety and haulage

- The battery pack is protected against damages to its internal cells during transport, because of overload or inverted current.
- The single lithium-ion cells comply with the UL1642 safety standard.



---

## Docking Station

The Docking Station supplied with the UJB Kit allows accommodating the Portable Unit when not in use while at the same time recharging it, without the need of inserting/removing the AC/DC Adapter's plug.

When the Portable Unit is placed on its Docking Station, the display may be read from a distance.



Figure 10 Docking Station

### Docking Station warnings

- The Docking Station has been designed to be placed on a flat surface: therefore, do not place it on an inclined or unstable surface.
- Do not place any metal part on the Docking Station's contacts.
- Do not smear the Docking Station's contacts with oil or grease.
- Before cleaning the contacts, disconnect the mains cable from the AC/DC Adapter.



---

## AC/DC Adapter

The supplied AC/DC Adapter must be exclusively used to supply the Portable Unit and to recharge the battery pack.

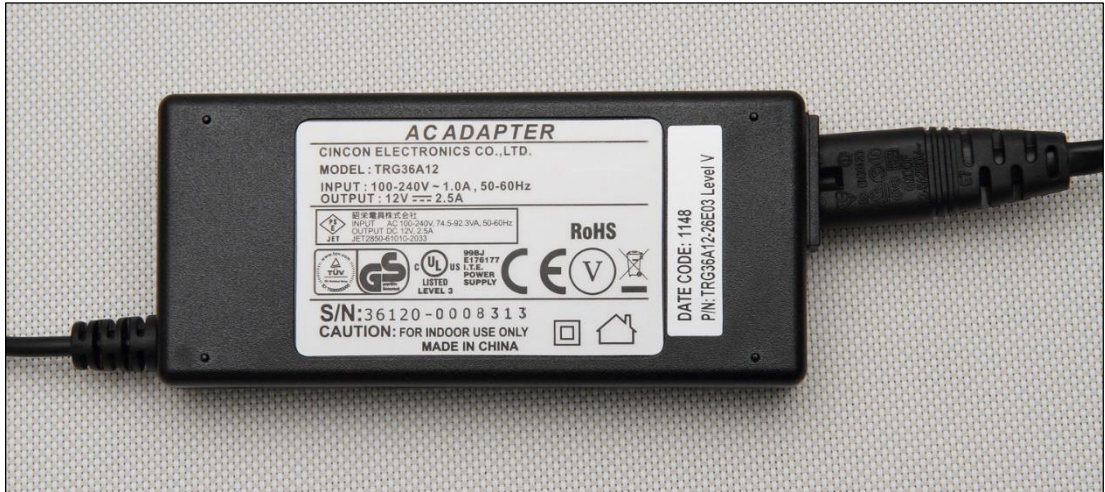

Figure 11 AC/DC Adapter

As already stated, in order to supply the Portable Unit only use this AC/DC Adapter supplied with the UJB Kit.

In case of fault, the replacement unit's code is: **G596614xx**.

### AC/DC Adapter technical data

Input voltage	90÷260 Vac, 50/60 Hz
Output	12 V ---, 2.5 A
Full recharge time	3 hours
Operating temperature	+5° ÷ 45°C
Degrees of protection	IP40
Marked	UR, CSA, TUV-GS

### AC/DC Adapter use warnings

The advices and warnings contained in this section must be carefully observed.

#### ***Before using the Adapter***

- Carefully read all instructions before using the AC/DC Adapter.
- Place the Adapter away from liquids and heat sources.
- Place the Adapter so that the power cord is always accessible and easy to remove.
- Make sure that the input power supply meets the requirements.

## Using the Adapter

The supplied AC/DC Adapter must be exclusively used to power supply the Portable Unit and to recharge the battery pack.

Any other use is considered improper and therefore dangerous. Hexagon Metrology cannot be held responsible for the consequences arising from the improper, incorrect or unreasonable use of the Adapter.

---

**Note:** using an AC/DC adapter different from the supplied one could reduce the system's safety conditions and will void the kit's warranty and TUV certification.

---

While using the Adapter, strictly observe the following rules:

- Do not touch the Adapter with wet hands and/or feet.
- Do not use the Adapter while barefoot.
- Do not leave the Adapter exposed to atmospheric agents.
- Do not allow the Adapter to be used by those who do not know the functioning.

When not using the Adapter for prolonged period of times, disconnect it from the mains plug.

## AC/DC Adapter maintenance

Problem	Suggested remedy
The power cord is damaged	Replace the power cord with one of similar characteristics
The output connector is damaged	Contact the Hexagon Metrology's customer service

---

## Using the UJB Kit in a dual-arm measuring system

When using the UJB Kit in a dual-arm measuring system, it is important to observe the following rules:

- Before powering the measuring system on, turn on the Portable Units and verify that the STOP button is released on both of them.
- This rule should also be observed when starting a single system of measurement in SINGLE ARM mode. Regardless of whether the arm that is not in use is on or off, turn on the power of both handsets and make sure that both STOP buttons are released.

# UJB Quick Reference Guide

This chapter provides a summarized description of the commands, buttons and symbols of the UJB Portable Unit.



UJB









MAIN SCREEN

**Icon Glossary**

	DONE		SHIFT
	PRINT		CLAMPING
	RUN		PROBE PRESSURE
	HOLD		BALANCE
	PROBE ENABLE		HOME PAGE
	OPERATOR POSITION		EXTERNAL HOST PAGE
	DELETE POINT		PAGE RIGHT
	JOG MODE		PAGE LEFT
	SLOW MODE		MACHINE
	X-AXIS ENABLE		SERVICE PAGE
	Y-AXIS ENABLE		WIRELESS PAGE
	Z-AXIS ENABLE		LOCK / UNLOCK

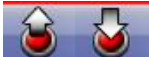
## Status Indicator Icons

	Battery indicator – Visible when Wireless mode is enabled
	Wireless page Indicator – Visible when Wireless mode is enabled
	<i>Bluetooth</i> Indicator – Visible when <i>Bluetooth</i> function is enabled
	CMM Machine indicator – Green Icon = Drives ON, Grey Icon = Boot completed; Flashing Red/Yellow = no mobile to base unit communications
	Wireless Stop indicators – Visible only when wireless mode is enabled
	Wireless initialization state – Visible only when wireless mode is enabled

## General Operating Note

Users should be aware that during normal operation the icon will momentarily change to halftone when the user touches an icon on the display. The purpose of the halftone is to provide feedback to the operator that a touch has been registered with the controller for action and prevent a user from mistakenly touching the display a second time and reversing the intended action. The touch-screen display does not support multi press operation.

## Home Screen & Icons Definitions

**NOTE:** Machine Start Icon Values: Green Icon = Drives **ON**, Grey Icon = Drives **OFF**

Machine status indicator flashing Red/Yellow = No communications between the mobile and the base unit.

Pressing the Home Icon in the navigation banner on the Main screen will return you to the Home screen.

Pressing the Home Icon in the navigation bar of the Home page or PC-DMIS Capable page will take you to the previous page.



## Unit Operation

The boot cycle completes once you have completed installation and powered up the UJB, with STOP button released, and after having switched the control system on. When the controller completes the boot cycle the X, Y and Z Icons on the main screen will change from green to grey.

Press the machine start button located in the lower right quadrant of the UJB, depress the right or left enable buttons located in the center of the UJB and jog the machine with your joystick.

The UJB comes with a touch screen display for ease of operation. Depressing the Touch Screen graphic Icons will issue commands to the controller to initiate an action. When an Icon is pressed a halo will temporarily light the periphery of the Icon indicating a press has been initiated. The Icon will change color when the LED is lit.

The screen is divided into 3 sections, upper banner, main screen icons and navigation section. To operate the machine you will be primarily using the main screen. For gloved screen and probe function screen operation please refer to CMM Gloved Operation Screens on page 16.