

# HI-LINK 802.11B/G USB Module Product Specifications

Model: HLK-2M01-XX

Version: 2.0

16 Aug 2011

# Contents

<b>1 Introduction</b> .....	<b>3</b>
1.1 Scope:.....	3
1.2 Features .....	3
<b>2 Product Information</b> .....	<b>4</b>
2.1 Specification Overview .....	4
2.2 Hardware Information.....	4
2.3 Software and system Information .....	5
2.3.1 Operating System .....	5
2.3.2 Minimum System Requirement.....	5
2.4 Mechanical Information.....	5
2.4.1 PCBA Dimensions (include USB connector).....	5
<b>3 Agency Approval</b> .....	<b>6</b>
<b>4 Environment</b> .....	<b>6</b>
4.1 Temperature .....	6
4.1.1 Operating Temperature Conditions.....	6
4.1.2 Non-Operating Temperature Conditions (including warehouse).....	6
4.2 Humidity .....	6
4.2.1 Operating Humidity Conditions .....	6
4.2.2 Non-Operating Humidity Conditions (including warehouse) .....	6

# 1 Introduction

The RT2571 based USB module is an IEEE 802.11 b/g standard USB Module

## 1.1 Scope:

The RT2571 base USB module WLAN Module is designed to operate in 2.4GHz ISM frequency band. This Module complies with IEEE 802.11b and IEEE 802.11g standards.

## 1.2 Features

- Complies with IEEE 802.11b, IEEE 802.11g.
- Dynamic data rate: Maximum data rate up to 54Mbps. Auto fallback switching with 48, 36, 24, 18, 12, 11, 9, 6, 5.5, 2 and 1Mbps.
- Security support for 64/128 WEP / WPA.
- Supporting WPS or software API.
- Operates in 2.4GHz frequency bands.
- Antenna configuration: PCB antenna
- Drivers supporting Linux, Window XP/Vista and WinCE 5.0.
- RoHS Compliance

## 2 Product Information

### 2.1 Specification Overview

<b>Standards</b>	IEEE802.11b and 802.11g
<b>Operating Frequency</b>	USA (FCC): 2.412GHz ~ 2.462GHz ISM band (channel 1 – 11) Europe (CE): 2.412GHz ~ 2.472GHz ISM band (channel 1 – 13)
<b>Channel Bandwidth</b>	20MHz
<b>Protocols</b>	802.11b: CCK, QPSK, BPSK 802.11g: OFDM
<b>Antenna</b>	PCB antenna
<b>Security</b>	WPA, 64/128/152-bit WEP, WPS
<b>Transmit Output Power</b>	11b: 13dBm @ 11Mbps (Typical) 11g: 13dBm @ 54Mbps (Typical)
<b>Receive Sensitivity</b>	11b: -82dBm @ 11Mbps (Typical) 11g: -68dBm @ 54Mbps (Typical)
<b>Operating Voltage</b>	5V DC $\pm$ 5%
<b>Bus Interface</b>	USB 2.0
<b>USB Connection</b>	A-type USB 2.0 Connector,

### 2.2 Hardware Information

The RT2571 based USB module is low-cost compact WLAN USB module. The USB module uses Ralink RT2571 (MAC) and RT2528 (Transceiver) to implement IEEE 802.11b/g standards.

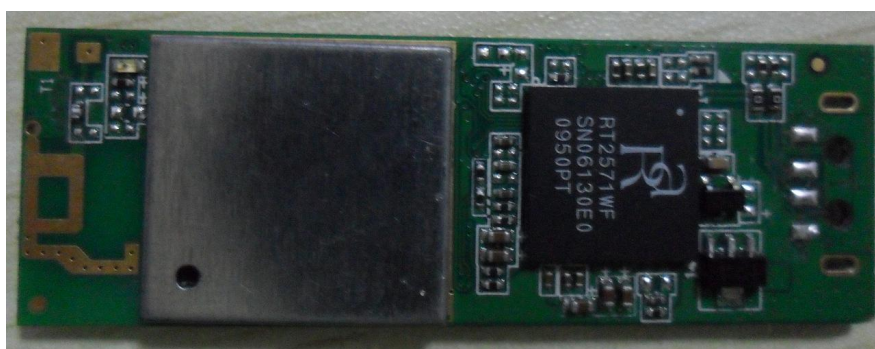

## 2.2.1 Block Diagram

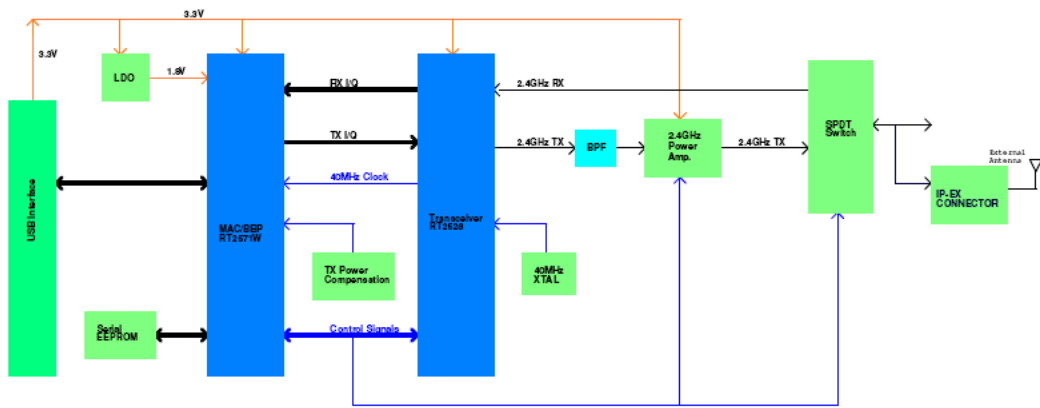

**Figure 1:** System Block Diagram of the RT2571 based USB module WLAN Module

## 2.3 Software and system Information

### 2.3.1 Operating System

Operation System	CPU Supplier	Driver
Linux 2.6.x	Intel, Atmel	Available
Windows 2000/XP/Vista	Intel	Available
Windows CE 5.0	Intel, Samsung	Available

### 2.3.2 Minimum System Requirement

- 600MHz or Faster PC
- 512MB RAM Memory
- Available USB 2.0 Interface

## 2.4 Mechanical Information

### 2.4.1 PCBA Dimensions (include USB connector)

Size: LxWxH 60.7\*20.2\*4.3mm

Weight: ~3.8g

## **3 Agency Approval**

## **4 Environment**

### 4.1 Temperature

#### 4.1.1 Operating Temperature Conditions

The product is capable of continuous reliable operation when operating in ambient temperature of 0°C to +55°C.

#### 4.1.2 Non-Operating Temperature Conditions (including warehouse)

The product is not damaged or degraded when keeping in the temperature range of -10°C to +70°C.

### 4.2 Humidity

#### 4.2.1 Operating Humidity Conditions

The product is capable of continuous reliable operation when subjected to relative humidity in the range of 20% to 80% (non-condensing).

#### 4.2.2 Non-Operating Humidity Conditions (including warehouse)

The product is not damaged or degraded when kept in the relative humidity range from 20% to 80% (non-condensing).

This device complies with the following radio frequency and safety standards.

### **FCC Warning**

**Important to OEM Manufacturer:**

**This following FCC Warning must be included in the HOST User Manual.**

This device complies with Part 15 of the FCC Rules. Operation is subject to the following two conditions:

(1) this device may not cause harmful interference, and (2) this device must accept any interference received, including interference that may cause undesired operation.

NOTE 1: This equipment has been tested and found to comply with the limits for a Class B digital device, pursuant to part 15 of the FCC Rules. These limits are designed to provide reasonable protection against harmful interference in a residential installation. This equipment generates, uses and can radiate radio frequency energy and, if not installed and used in accordance with the instructions, may cause harmful interference to radio communications. However, there is no guarantee that interference will not occur in a particular installation. If this equipment does cause harmful interference to radio or television reception, which can be determined by turning the equipment off and on, the user is encouraged to try to correct the interference by one or more of the following measures:

- Reorient or relocate the receiving antenna.
- Increase the separation between the equipment and receiver.
- Connect the equipment into an outlet on a circuit different from that to which the receiver is connected.
- Consult the dealer or an experienced radio/TV technician for help.

NOTE 2: The manufacturer is not responsible for any changes or modifications not expressly approved by the manufacturer for compliance, such modifications could void the user's authority to operate the equipment.

### **FCC Radiation Exposure Statement:**

This equipment complies with FCC radiation exposure limits set forth for an uncontrolled environment. End users must follow the specific operating instructions for satisfying RF exposure compliance.

**Note 1:** This module certified that complies with RF exposure requirement under portable or mobile or fixed condition, this module is to be installed only in portable or mobile or fixed applications.

A portable device is defined as a transmitting device designed to be used so that the radiating structure(s) of the device is/are within 20 centimeters of the body of the user

A mobile device is defined as a transmitting device designed to be used in other than fixed locations and to generally be used in such a way that a separation distance of at least 20 centimeters is normally maintained between the transmitter's radiating structure(s) and the body of the user or nearby persons. Transmitting devices designed to be used by consumers or workers that can be easily re-located, such as wireless devices associated with a personal computer, are considered to be mobile devices if they meet the 20 centimeter separation requirement.

A fixed device is defined as a device is physically secured at one location and is not able to be easily moved to another location.

**Note 2:** Any modifications made to the module will void the Grant of Certification, this module is limited to OEM installation only and must not be sold to end-users, end-user has no manual instructions to remove or install the device, only software or operating procedure shall be placed in the end-user operating manual of final products.

**Note 3:** The device must not transmit simultaneously with any other antenna or transmitter.

**Note 4:** To ensure compliance with all non-transmitter functions the host manufacturer is responsible for ensuring compliance with the module(s) installed and fully operational. For example, if a host was previously authorized as an unintentional radiator under the Declaration of Conformity procedure without a transmitter certified module and a module is added, the host manufacturer is responsible for ensuring that the after the module is installed and operational the host continues to be compliant with the Part 15B unintentional radiator requirements. Since this may depend on the details of how the module is integrated with the host, HI-LINK shall provide guidance to the host manufacturer for compliance with the Part 15B requirements.

**Note 5:** FCC ID label on the final system must be labeled with “Contains FCC ID: ZXVHLK-2MXX” or “Contains transmitter module FCC ID: ZXVHLK-2MXX”.

The transmitter module must be installed and used in strict accordance with the manufacturer's instructions as described in the user documentation that comes with the host product. SHENZHEN HI-LINK ELECTRONIC CO., LTD is responsible for the compliance of the module in all final hosts.