



Hilti Corporation

FL-9494 Schaan

Tel.: +423 / 234 21 11

Fax: +423 / 234 29 65

www.hilti.com

000000 / A

HILTI

PR 25

Bedienungsanleitung
Operating instructions

de
en



CE

1

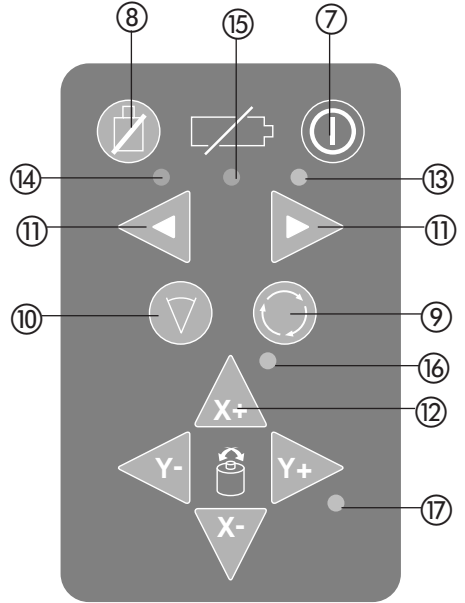
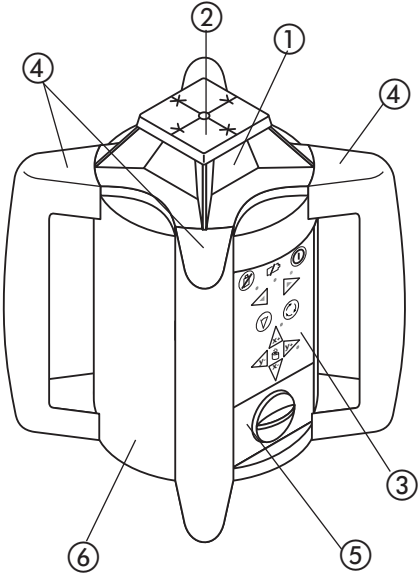

2

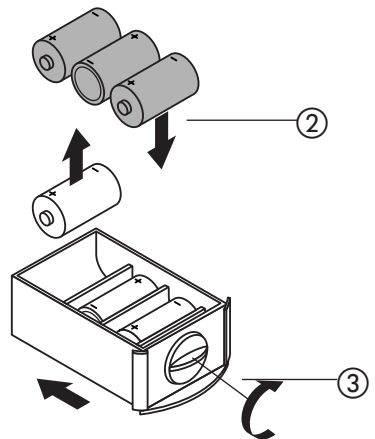
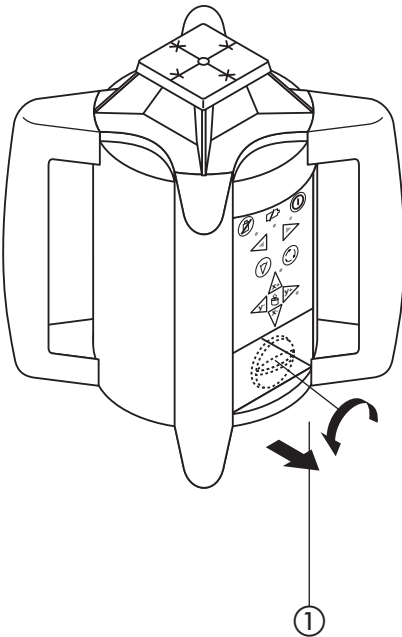

3

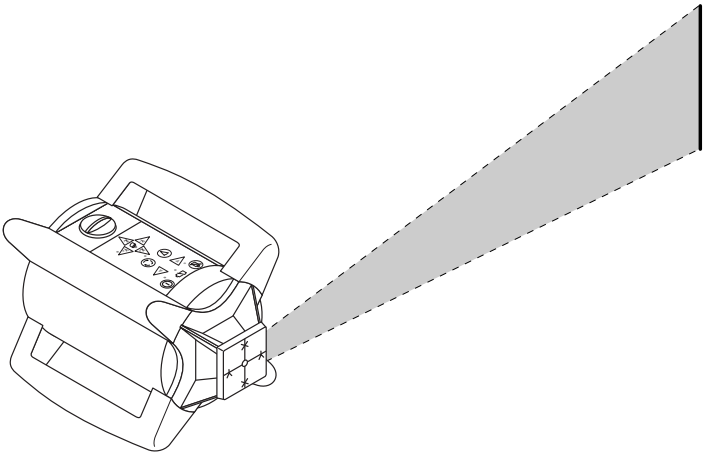

4

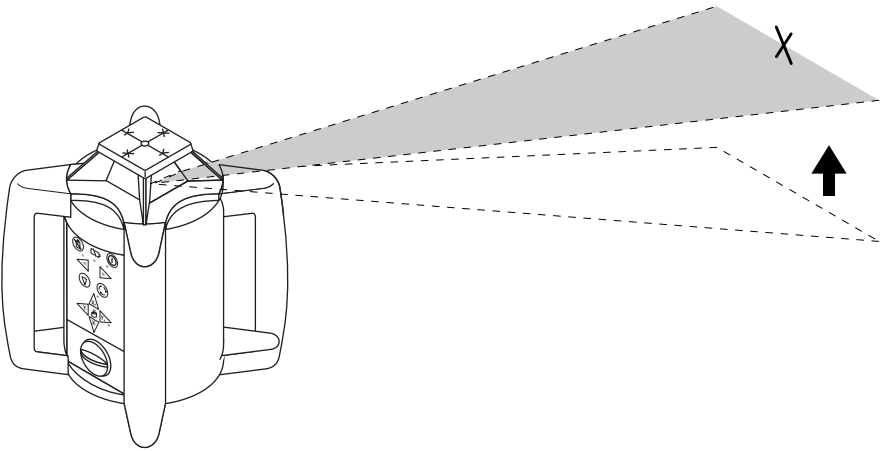

5

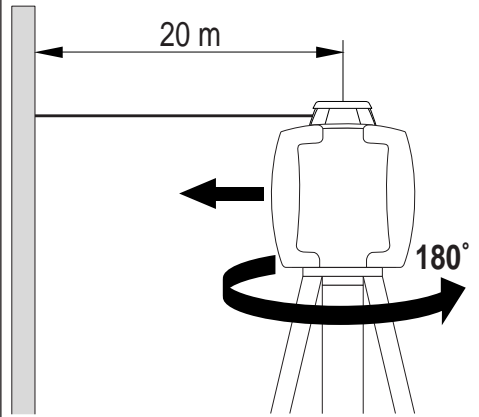
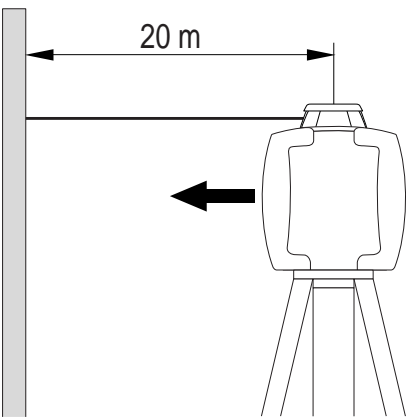

PR 25 rotating laser

It is essential that the operating instructions are read before the tool is used the first time.

Always keep these operating instructions together with the tool.

Ensure that the operating instructions are with the tool when it is given to other persons.

Component parts **1**

PR 25 rotating laser

- ① Laser beam (plane of rotation)
- ② Rotating head
- ③ Control panel
- ④ Grip
- ⑤ Battery compartment
- ⑥ Base plate with $\frac{5}{8}$ " thread

Control panel

- ⑦ On/off button
- ⑧ Shock warning deactivation key
- ⑨ Rotation speed control key
- ⑩ Line function key
- ⑪ Direction keys (left/right)
- ⑫ Servo keys (set X/Y inclination/direction)
- ⑬ Auto leveling LED
- ⑭ Shock warning deactivation LED
- ⑮ Battery LED
- ⑯ X-inclination/direction LED
- ⑰ Y-inclination/direction LED

PRA 25 laser receiver

Contents	Page
1. General information	1
2. Description	2
3. Accessories	2
4. Technical data	3
5. Safety precautions	3
6. Before use	5
7. Operation	6
8. Checks/adjustment	8
9. Care and maintenance	9
10. Disposal	9
11. Warranty	10
12. FCC statement	10
13. EC declaration of conformity	11

1. General information

1.1 Safety notices and their meaning

-CAUTION-

Draws attention to a potentially dangerous situation that could lead to minor personal injury or damage to the equipment or other property.

-NOTE-

Draws attention to instructions and other useful information.

1.2 Pictograms

Warning signs



General warning

Symbols



Read the operating instructions before use.



Laser radiation

Do not stare into the beam.

Laser class 2 in accordance with EN 60825-1:2003



Do not stare into the beam or look directly into the beam with other optical instruments.

Laser class 3A in a accordance with EN 60825-1:2003

1 These numbers refer to the corresponding illustrations. The illustrations can be found on the fold-out cover pages. Keep these pages open when studying the operating instructions.

In these operating instructions, the PR 25 rotating laser is referred to as "the tool".

Location of identification data on the tool

The type designation and serial number can be found on the type plate on the tool. Make a note of this data in your operating instructions and always refer to it when making an enquiry to your Hilti representative or service department.

Type: PR 25

Serial no.:

2. Description

2.1 PR 25 rotating laser

The PR 25 is a rotating laser featuring a visible rotating laser beam plus a point laser beam set at 90° to the rotating beam, which can be used to indicate the vertical, horizontal or inclined planes.

2.2 Features

The tool allows a single person to level or align in any plane quickly and with great accuracy.

Automatic leveling (within $\pm 5^\circ$ inclination): The tool levels itself automatically after switching on. The laser beam is emitted only when the specified accuracy has been achieved.

LEDs indicate the tool's operating status.

Speed of rotation

The tool features 4 speeds of rotation. These are: stationary spot (zero rotation), slow rotation, medium-speed rotation and fast rotation.

It is possible to switch between functions such as "Rotating laser" and "Line laser". This can be done from the PR25 rotating laser or by way of the PRA 25 (combined laser receiver and remote control unit).

Shock warning

The built-in shock warning function becomes active one minute after switching on: The tool switches to warning mode (all LEDs blink, laser stops rotating) when brought out of level as a result of vibration or an impact during operation. All LEDs blink and the laser stops rotating.

Automatic cut-out

If movement of the mechanism is physically impeded or the tool is set up outside its self-leveling range, the laser remains switched off and all LEDs blink.

The tool can be set up on a tripod with a $\frac{5}{8}$ " thread or stood directly on some other steady surface (free of vibration).

-NOTE-

In some versions sold, the PRA 25 is not supplied as standard with the PR 25. In this case, the functions can be controlled directly from the PR 25 rotating laser itself (excluding auto alignment/surveillance, which is possible only in conjunction with the PRA 25).

2.3 Description of functions

2.3.1 Horizontal plane (automatic leveling)

When switched on, the tool levels itself automatically by way of the 2 built-in servo motors for the X- and Y-directions.

2.3.2 Inclined plane (any desired inclination)

Inclination can be set up in alignment with given marks by pressing the X- and Y-keys on the PRA 25 or PR 25.

2.3.3 Automatic cut-out

During automatic leveling in one or both directions, the servo system monitors compliance with the specified accuracy.

The tool switches itself off in the following situations:

- Leveling is not accomplished (tool set up outside its leveling range or the mechanism is physically impeded).
- The tool is brought out of level (due to vibration or impact).

After automatic cut-out, rotation of the laser beam stops and all LEDs blink.

Items supplied

- 1 PR 25 rotating laser
- 1 PRA 25 laser receiver*
- 1 PR 25 operating instructions
- 1 PRA 25 operating instructions*
- 1 PR 25/PRA 25 operating instructions*
- 1 PRA 50/1 target plate
- 1 producer certificate
- 3 batteries (size D cells)
- 2 batteries (size AA cells)
- 1 Hilti case

* Depending on the version purchased, this may not be included in the items supplied.

3. Accessories

3.1 Accessories for the PR 25

Many tasks can be carried out much more efficiently when the appropriate accessories for the PR 25 are used.

The following accessories are available:

- PRA 20 and PRA 25 laser receiver
- PRA 50 and PRA 51 target plates
- PRA 52 slope calculator
- PRA 70 and PRA 71 wall mounts

- PRA 76 slope adapter
- PRA 75 laser receiver holder
- PUA 80 charger and PRA 801 battery pack
- PA 375 batter board adapter, PA 377 tripod and facade adapter
- PA 910, PA 911, PA 921 and PA 931/2 tripods
- PA 950/960 and PA 951/961 telescopic staffs

en

4. Technical data for the PR 25

Range (diameter)	2 to 200 m [6 to 650 ft.] with the PRA 25
Range of remote control	0 to 100 m [0 to 325 ft.] with the PRA 25
Accuracy (at 24 °C/+75 °F)	±0.75 mm @ 10 m
Plumb beam	Continuously at right angles to plane of rotation
Laser product class	Class 2, visible, 635 nm, < 1 mW Class 3A, visible, 635 nm, < 2.5 mW (IEC825-1/EN60825-1:2003; FDA 21 CFR 1040)
Speeds of rotation	Zero, slow, medium, fast (operating speed)
Self-leveling range	±5°, LED indicator
Automatic cut-out	When the laser is brought out of level (unless both axes set to inclined mode): - Rotation stops - All LEDs blink
Operating status indicators	- Auto leveling LED - Battery condition LED - Shock warning LED - X and Y inclination/direction LED
Power supply	3 size D alkaline batteries or NiMH rechargeable battery for charging with PUA 80 charger (accessory)
Battery life at 20 °C [+68 °F]	Alkaline batteries: > 50 hours NiMH batteries: > 40 hours
Operating temperature	-20 °C to +50 °C [-4 °F to +122 °F]
Storage temperature	-30 °C to +60 °C dry [-22 °F to +140 °F]
Protection class	IP 56 (as per IEC 529)
Tripod thread	5/8" x 18
Weight	Approx. 2.4 kg (5.3 lbs.) including 3 batteries
Dimensions	186 (L) x 186 (W) x 213 (H) mm [7.3" (L) x 7.3" (W) x 8.4" (H) inches]
Beam diameter	< 16 mm at 10 m

Right of technical changes reserved.

5. Safety precautions

5.1 Basic information concerning safety

In addition to the information relevant to safety given in each of the sections of these operating instructions, the following points must be strictly observed at all times.

5.2 Intended use

The tool is designed to be used for determining, transferring or checking alignment in the horizontal plane, inclined planes and right angles, e.g.

- Transferring datum and height marks
- Marking out right angles for walls
- Vertical alignment with a reference point
- Setting out inclines

Hilti offers various accessories that allow the tool to be used with maximum efficiency.



- The tool and its accessories may present hazards when used incorrectly by untrained personnel or when used not as directed.
- To avoid the risk of injury, use only genuine Hilti accessories and additional equipment.
- Tampering with or modification of the tool is not permissible.
- Observe the information printed in the operating instructions concerning operation, care and maintenance.
- Do not render safety devices ineffective and do not remove information and warning notices.
- Keep laser tools out of reach of children.
- Have the tool repaired only at a Hilti service center. Failure to follow the correct procedures when opening the tool may cause emission of laser radiation in excess of class 2 or, respectively, class 3A.
- Take the surrounding conditions into account. Do not use the tool where there is a risk of fire or explosion.

* (Requested by FCC §15.21): Changes or modifications not expressly approved by the party responsible for compliance could void the user's authority to operate the equipment.

5.3 Proper organization of the workplace



- Secure the area in which you are working. When setting up the tool, take care to avoid directing the beam toward yourself or other people.
- Avoid unfavorable body positions when working on ladders. Work from a stable stance and stay in balance at all times.
- Measurements taken through panes of glass or other objects may be inaccurate.

- Ensure that the tool is set up on a steady surface (not subject to vibration).
- Use the tool only within its specified limits.
- Check that your PR 25 is being controlled by your PRA 25 and that it is not reacting to commands from any other PRA 25 in use on the construction site.

5.3.1 Electromagnetic compatibility

Although the tool complies with the strict requirements of the relevant directives, Hilti cannot entirely rule out the following possibilities:

- The tool may cause interference to other equipment, e.g. aircraft navigational equipment.
- The tool may be subject to interference caused by powerful radiation, possibly leading to incorrect operation. Check the readings for plausibility when measuring under these conditions or if you are unsure of the results.

5.3.2 Laser classification for laser class 2 products

Depending on the version purchased, the tool conforms to laser class 2 or, respectively, class 3A based on the IEC825-1/EN60825-1:2003 standard and class 3 based on CFR 21 § 1040 (FDA). These tools may be used without need for further protective measures. The eyelid closure reflex protects the eyes if a person looks into the beam unintentionally for a brief moment. The eyelid closure reflex may, however, be negatively influenced by medication, alcohol or drugs. Nevertheless, as with the sun, a person should not look directly into sources of bright light. Do not direct the laser beam toward persons.

Laser warning plates based on IEC825/EN60825-1:2003



Laser warning plates for the US based on CFR 21 § 1040 (FDA)



5.3.3 Laser classification for laser class 3A products

Depending on the version purchased, the tool conforms to laser class 3 based on the CFR 21 § 1040 (FDA) standard. These tools may be used without need for further protective measures.

Do not look into the laser beam and do not direct the laser beam toward persons.

Laser warning plate based on IEC825/EN60825-1:2003



Laser warning plate for the US based on CFR 21 § 1040 (FDA)



This laser product complies with 21 CFR 1040 as applicable.

-NOTE-

- Laser class 3A tools should be operated only by trained personnel.
- The area in which the tool is in use should be marked with laser warning signs.
- The plane of the laser beam should be well above or well below eye level.
- Precautionary measures must be taken to avoid inadvertent reflection of the laser beam from potentially reflective surfaces.
- Precautionary measures must be taken to ensure that persons do not look directly into the beam.
- The laser beam should not be projected into unsupervised areas.
- When not in use, laser tools should be stored in a place inaccessible to unauthorized persons.

5.4 General safety precautions

- Check the tool before use. If the tool is found to be damaged, have it repaired at a Hilti service center.
- The accuracy of the tool must be checked after it has been dropped or subjected to other mechanical stress.
- When the tool is brought into a warm environment from very cold conditions, or vice versa, allow it to become acclimatized before use.
- If mounting on an adapter, ensure that the tool is screwed on securely.
- Keep the laser exit aperture clean to avoid measurement errors.
- Although the tool is designed for the tough conditions of jobsite use, as with other optical instruments (binoculars, spectacles, cameras) it should be treated with care.
- Although the tool is designed to prevent entry of dampness, it should be wiped dry each time before being put away in its transport container.
- Check the tool before using it for important measuring work.
- Check the accuracy of the tool regularly while in use.

5.4.1 Electrical

- Do not allow the batteries to fall into children's hands.
- Do not overheat or incinerate the batteries. They may explode or release toxic substances.
- Do not attempt to recharge the batteries (non-rechargeable, alkaline type).
- Do not solder the batteries into the tool.
- Do not discharge the batteries by short circuiting. This may cause the batteries to overheat and swell up.
- Do not attempt to open the batteries and do not subject them to excessive mechanical stress.

6. Before use



en

-NOTE-

- The tool may be powered only by the PRA 801 battery pack or by batteries manufactured in accordance with the IEC standard.

PR 801 battery pack

- The performance of the battery drops at low temperatures.
- Store the battery at room temperature.
- Never store the battery where it is exposed to direct sunlight, on a radiator or heater, or behind glass (windows, motor vehicle windscreens, etc).

Batteries

- Do not use damaged batteries.
- Do not mix old and new batteries. Do not mix batteries of different types or batteries from various manufacturers.

6.1 Switching on the tool

Press the on/off key.

-NOTE-

After switching on, the tool begins the automatic leveling process (max. 40 seconds). Once fully leveled, the tool activates the laser beam in the rotational plane and in the beam perpendicular to this. The laser beam begins to rotate at medium speed.

6.2 LED indicators

Auto leveling LED

The LED blinks rapidly.	The tool is leveling itself automatically.
The LED lights constantly.	The tool has leveled itself/is operating normally.

Shock warning LED

All LEDs blink.	The tool has been bumped or brought out of level temporarily.
The shock warning LED lights red.	The shock warning LED lights red after deactivation of the shock warning.

Battery voltage LED

The LED lights.	The batteries are almost exhausted.
-----------------	-------------------------------------

Inclination LED

The X and Y LEDs do not light.	Operation in the horizontal plane.
The X LED does not light and the Y LED lights red.	The Y-direction has been aligned manually or by way of auto alignment. X-direction is still under automatic control.
The X LED lights red and the Y LED does not light.	The X-direction has been aligned manually or by way of auto alignment. Y axis is still under automatic control.
The X LED lights red and the Y LED lights red.	The X- and Y-directions have been aligned manually or by way of auto alignment. The shock warning system is deactivated.

6.3 Inserting new batteries 2

1. Open the battery compartment by turning the locking button.
2. Insert the batteries in the battery compartment. Take care to ensure correct polarity.
3. Close the battery compartment by turning the locking button.

7. Operation



7.1 Switching the tool on

Press the on/off key.

7.2 Selecting the speed of rotation

The speed of rotation can be adjusted by pressing the rotation speed control key (PR 25 or PRA 25). After switching on, the PR 25 is set to rotate at medium speed, as standard.

- Press the key once to set rotation to medium speed.
- Press the key again to set rotation to high speed.
- Press the key once more to return to medium speed.
- Press the key yet again to set rotation to low speed.
- A further press of the key stops rotation (spot).
- The next press of the key sets rotation to low speed.
- This procedure repeats itself.

7.2.1 Selecting the line function **3**

After pressing the line function key, the PR 25 projects a laser line. The line can be lengthened or shortened by pressing the key again.

- Press the key once to project a short line.
- Press the key again to project a medium-length line.
- Press the key once more to project a long line.
- Press the key yet again to project an extra-long line.
- A further press of the key switches the tool back to the long line.
- The next press of the key switches the tool back to the medium-length line.
- This procedure repeats itself.

7.2.2 Moving the laser line and spot

The laser line or laser spot can be moved to the left or right by pressing the direction keys (PR 25 or PRA 25). Holding down the direction keys increases the speed of movement and the laser line or spot then move continuously.

7.2.3 Working in the horizontal plane

- Mount the tool suitably, depending on the application, e.g. on a tripod.
- Press the on/off key.

-NOTE-

The laser beam switches on and begins to rotate as soon as the tool has leveled itself.

7.2.4 Working in the vertical plane

- Stand the tool on a level surface in a suitable position for the application.*
- Press the on/off button.

-NOTE-

*In order to ensure that the specified accuracy is maintained, the tool should be stood on an approximately level surface.

-NOTE-

The X LED does not light (the X-direction is brought into vertical alignment automatically and monitored).

The Y LED lights red (the Y-direction can be aligned manually by way of the servo keys, the laser plane remains perpendicular).

7.2.5 Automatic alignment

A basic prerequisite for auto alignment is that the PR 25 is set up accurately. The PR 25 must be set up so that the correct axis (X or Y) is positioned in the direction in which alignment is to be performed. This can only be done in conjunction with the PRA 25.

Procedure:

- Position the PR 25 at the reference point and with the correct axis in the direction in which alignment is to be performed (the operating range for auto alignment is a radius of 5-50 m).
- Position the PRA 25 laser receiver at the desired point.
- Check that no obstacles prevent communication between the PR 25 and the PRA 25.
- Activate the auto alignment function by pressing the X or Y key three times within one second. It is important that the axes correspond correctly, i.e. when X (Y) is to be aligned with the reference point, auto alignment of the X (Y) axis must be enabled by way of the PRA 25.
- As long as the PR 25 is not in line laser mode, it then switches automatically to medium rotation speed and begins the search process. The auto align function is indicated in the display by the axis currently being aligned and by blinking arrows. An audible signal is emitted continuously during the search process.
- The direction of the search process can be changed by pressing the direction arrows.
- The beam moves to the zero point (reference plane) as soon as the laser beam strikes the detection area on the PRA 25 laser receiver.
- After reaching this point (finding the reference plane), a signal sounds briefly indicating that the process is complete. Only the axis that has been aligned is then shown in the display.

If the process cannot be completed within a certain period of time, an error is indicated in the display.

-NOTE- If an error is displayed

Please check that the PRA 25 is positioned within the inclination range ($\pm 5^\circ$) and that no obstacles are located between the rotating laser and the laser receiver.

7.2.6 Manual alignment with the PR 25 4

A basic prerequisite for manual alignment is that the PR 25 is set up accurately. The PR 25 must be set up so that the correct axis (X or Y) is positioned in the direction in which alignment is to be performed.

Procedure:

- Position the PR 25 at the reference point and with the correct axis in the direction in which alignment is to be performed (the operating range for manual alignment is a radius of 5–50 m).

Setting the X-direction manually

- Press one of the X-servo keys twice within 2 seconds.
- The X-servo keys can then be used to perform manual alignment.

-NOTE-

The X LED lights red.

Setting the Y-direction manually

- Press one of the Y-servo keys twice within 2 seconds.
- The Y-servo keys can then be used to perform manual alignment.

-NOTE-

The Y LED lights red.

7.2.7 Manual alignment using the PRA 25

A basic prerequisite for manual alignment is that the PR 25 is set up accurately. The PR 25 must be set up so that the correct axis (X or Y) is positioned in the direction in which alignment is to be performed.

Procedure:

- Position the PR 25 at the reference point and with the correct axis in the direction in which alignment is to be performed (the operating range for manual alignment is a radius of 5–50 m).
- Check that no obstacles prevent communication between the PR 25 and the PRA 25.
- Activate the manual alignment function by pressing the X or Y key twice within 1 second. It is important that the axes correspond correctly, i.e. when X (Y) is to be aligned with the reference point, auto alignment of the X (Y) axis must be enabled by way of the PRA 25.
- The laser beam can be moved to the desired position

by pressing the direction keys. Holding down the direction keys increases the speed of movement and the laser line or spot then move continuously.

- The manual alignment function is indicated in the display by the axis currently being aligned and by stationary (constantly lit) arrows. An audible signal is also emitted continuously during the search process.
- The system switches to normal operation when no key is pressed within 5 seconds. Only the axis that has been aligned is then indicated in the display.

7.2.8 Surveillance

The surveillance function checks to ensure that no displacement of the aligned plane has occurred (e.g. due to vibration). If displacement has occurred, the laser plane is realigned to the zero point (as long as it is still within the detection area). An additional laser receiver is required for working with the surveillance function. A PRA 20 or PRA 25 may be used to detect the laser beam.

As surveillance begins by way of the auto alignment function, the PR 25 must be set up accurately. The PR 25 must be set up so that the correct axis (X or Y) is positioned in the direction in which alignment is to be performed.

Procedure:

- Position the PR 25 at the reference point and with the correct axis in the direction in which alignment is to be performed (the operating range for auto alignment is a radius of 5–50 m).
- Position the PRA 25 laser receiver at the desired point.
- Check that no obstacles prevent communication between the PR 25 and the PRA 25.
- Activation of this function requires the PRA 25 to be switched off. While pressing and holding the X or Y key (the key for the axis you wish to align), switch on the laser receiver by pressing the on/off key.
- The system is then in surveillance mode. The monitoring function is indicated in the display – the LEDs for the axis to be aligned and the arrows blink alternately.
- The auto alignment process then begins as previously described.
- The auto alignment process stops as soon as the zero point has been found. In contrast to full auto alignment, no audible signal is emitted at the end of the process.
- A check is carried out at regular intervals to ensure that laser the plane has not been displaced. If it is found to have been displaced, the laser plane is again brought into alignment with the zero point (as long as the laser beam is still within the detection area and line of sight between the rotating laser and the laser receiver has not been interrupted for a long period). In the event of prolonged interruption of the line of sight between the two devices, an error is indicated after 30 seconds.

-NOTE- If an error is displayed

Please check that the PRA 25 is positioned within the self levelling range ($\pm 5^\circ$) and that no obstacles are located between the rotating laser and the laser receiver. After successfully setting to the zero point, take care to ensure that the line of sight between the two devices is not interrupted.

7.2.9 Pairing

It is possible to configure the PR 25 and the PRA 25 as a pair. When the two devices are paired, the rotating laser and the detector are assigned to each other. The rotating laser then receives commands only from its "own" detector/remote control unit. The devices can be paired by pressing and holding down the on/off keys on both devices simultaneously.

**-NOTE-**

The PR 25 and PRA 25 are not paired when supplied. Each unpaired rotating laser receives commands from any unpaired laser receiver.

Pairing procedure:

- The devices can be paired by pressing and holding down the on/off keys on the PR 25 and PRA 25 simultaneously, as previously described, for more than 3 seconds. Successful pairing is confirmed by an audible signal emitted by the PRA 25 and by the LEDs on the PR 25 blinking.

Cancelling pairing:

- Pairing can be cancelled by pressing and holding down the on/off keys for more than 3 seconds. Cancellation of pairing can only be successful when the on/off keys on the PR 25 and PRA 25 are not pressed simultaneously. Successful cancellation of pairing is confirmed by the PRA 25 by the emission of an audible signal and by the symbol "!" displayed. The PR 25 confirms cancellation of pairing by causing all LEDs to blink.

7.2.10 Working with the target plate

The target plate improves visibility of the laser beam. The target plate for the PR 25 is particularly useful in bright conditions or wherever better visibility of the laser beam is required.

7.2.11 Working with the laser receiver

Please refer to the PRA 25 operating instructions for information about the laser receiver.

7.2.12 Continuing work in manual mode after a restart

In order to continue working in manual mode after a restart, it is necessary to press one of the "servo" keys on the PR 25 within 3 seconds.

7.2.13 Returning to standard mode

To return to standard mode, switch the tool off and then restart it.

8. Hilti calibration service

We recommend that the tool is checked by the Hilti Calibration Service at regular intervals in order to verify its reliability in accordance with standards and legal requirements.

Use can be made of the Hilti Calibration Service at any time, but checking at least once a year is recommended. The Calibration Service provides confirmation that the tool is in conformance, on the day it is tested, with the specifications given in the operating instructions.

The tool will be re-adjusted if deviations from the manufacturer's specification are found. After checking and adjustment, a calibration sticker applied to the tool and a calibration certificate provide written verification that the tool operates in accordance with the manufacturer's specification.

Calibration certificates are always required by companies certified according to ISO 900x.

Your local Hilti Center or representative will be pleased to provide further information.

8.1 Accuracy

The accuracy of the tool in the X- or Y-directions can be checked as described below.

8.1.1 Checking procedure 5

1. Set up the tool in the horizontal plane at a distance of about 20 m (60 ft) from a wall (can also be carried out with the tool set up on a tripod).
2. Make a mark on the wall with the aid of the laser receiver (select medium speed of rotation).
3. Pivot the tool through 180° about its own axis (check the same laser axis).
4. With the aid of the laser receiver, make a second mark on the wall.

If the check has been carried out carefully, the distance between the marks A and B should be less than 6 mm ($\frac{1}{32}$ inch; at 20 m from the wall).

⇒ In the event of a deviation in excess of this, please return the tool to a Hilti Service Center.

9. Care and maintenance

9.1 Cleaning and drying

- Blow dust off the lenses.
- Do not touch the glass with your fingers.
- Use only a clean, soft cloth for cleaning. If necessary, slightly moisten the cloth with pure alcohol or a little water.

-NOTE-

- Do not use any other liquids as these may damage the plastic parts.
- Observe the temperature limits when storing your equipment. This is particularly important in winter or summer, especially if the equipment is kept inside a vehicle (storage temperatures: -30 °C to +60 °C / -22 °F to +140 °F).

9.2 Storage

Remove the tool from its case if it has become wet. Clean and dry the tool, its carrying case and accessories (at max. temperature of 40 °C/108 °F). Re-pack the equipment only when it is completely dry.

Check the accuracy of the equipment before it is used after a long period of storage or transportation.

Remove the batteries if the tool is to be stored for a long period.

9.3 Transportation

Use either the original Hilti case or packaging of equivalent quality for transporting or shipping your equipment.

-CAUTION-

Always remove the batteries before shipping the tool.

10. Disposal

-CAUTION-

Improper disposal of the equipment may have serious consequences:

- The burning of plastic components generates toxic fumes which may present a health hazard.
- Batteries may explode if damaged or exposed to very high temperatures and thus cause poisoning, burns, acid burns or environmental pollution.
- Careless disposal may permit unauthorized and improper use of the equipment, possibly leading to serious personal injury, injury to third parties and pollution of the environment.

Most of the materials from which Hilti tools or appliances are manufactured can be recycled. The materials must be properly separated before they can be recycled. In many countries, Hilti has already made arrangements for taking back old tools and appliances for recycling. Ask Hilti Customer Service or your Hilti Representative for further information.

Should you wish to return the tool or appliance yourself to a disposal facility for recycling, proceed as follows: Dismantle the equipment as far as is possible without need for special tools.

Separate the individual parts as follows:

Part/assembly	Main material	Recycling
Housing, toolbox	Plastic	Plastics recycling
Control panel, display	Various	Electronics scrap
Servo motor	Metal	Scrap metal
Electronics	Various	Electronics scrap
Batteries	Alkaline manganese	*
Screws, small parts	Steel	Scrap metal



Only for EU countries

Do not dispose of electric tools together with household waste material!

In observance of European Directive 2002/96/EC on waste electrical and electronic equipment and its implementation in accordance with international law, electric tools that have reached the end of their life must be collected separately and returned to an environmentally compatible recycling facility.

11. Warranty

Hilti warrants that the product supplied is free of defects in material and workmanship. This warranty is valid as long as the product is operated and handled correctly, cleaned and serviced properly and in accordance with the Hilti operating instructions, all warranty claims are made within 12 months from the date of the sale (invoice date), and the technical system is maintained. This means that only genuine Hilti consumables, components and spare parts may be used with the product.

This warranty provides the free-of-charge repair or replacement of defective parts only. Parts requiring repair or replacement as a result of normal wear and tear are not covered by this warranty.

Additional claims are excluded, unless stringent national rules prohibit such exclusion. In particular, Hilti is not obligated for direct, indirect, incidental or consequential damages, losses or expenses in connection with, or by reason of, the use of, or inability to use the product for any purpose. Implied warranties of merchantability or fitness for a particular purpose are specifically excluded.

Send the product and/or related parts immediately upon discovery of the defect to the applicable Hilti marketing organization for repair or replacement.

This constitutes Hilti's entire obligation with regard to warranty and supersedes all prior or contemporaneous comments and oral or written agreements concerning warranties.

12. FCC statement (applicable in US) / IC statement (applicable in Canada)

-CAUTION-

This equipment has been tested and found to comply with the limits for a class B digital device, pursuant to part 15 of the FCC rules. These limits are designed to provide reasonable protection against harmful interference in a residential installation. This equipment generates, uses, and can radiate radio frequency energy and, if not installed and used in accordance with the instructions, may cause harmful interference to radio communications.

However, there is no guarantee that interference will not occur in a particular installation.

If this equipment does cause harmful interference to radio or television reception, which can be determined by turning the equipment on and off, the user is encouraged to try to correct the interference by one or more of the following measures:

- Re-orient or re-locate the receiving antenna.
- Increase the distance between the equipment and receiver.
- Connect the equipment to an outlet on a circuit different from that to which the receiver is connected.
- Consult the dealer or an experienced TV/radio technician for assistance.

Changes or modifications not expressly approved by Hilti could restrict the user's right to operate the equipment.

This device complies with Part 15 of the FCC Rules and RSS-210 of IC. Operation is subject to the following two conditions:

- (1) this device may not cause harmful interference, and
- (2) this device must accept any interference received, including interference that may cause undesired operation.

Information plates on the product:

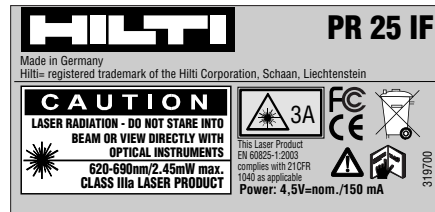
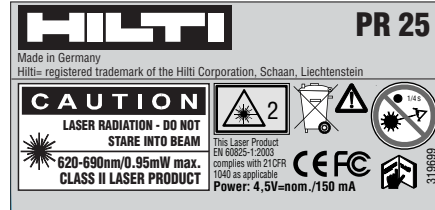

13. EC conformity

Designation:	Rotating laser
Type:	PR 25/PR 25 IF
Year of design:	2004

In conformance with CE 

We declare, on our own responsibility, that this product complies with the following directives and standards:
EN 300 440-2, EN 301 489-3 V1.4.1,
EN 60950-1:2001/IEC 60950-1:2001,
EN 55022 + A1 + A2:2003

Hilti Corporation



Matthias Gillner
Head BU Measuring Systems
01/2005



Dr. Heinz-Joachim Schneider
Executive Vice President
BA Electric Tools & Accessories
01/2005

en