



HILTI

Hilti Corporation

FL-9494 Schaan

Tel: +423 / 234 21 11

Fax: +423 / 234 29 65

www.hilti.com



HILTI

ND

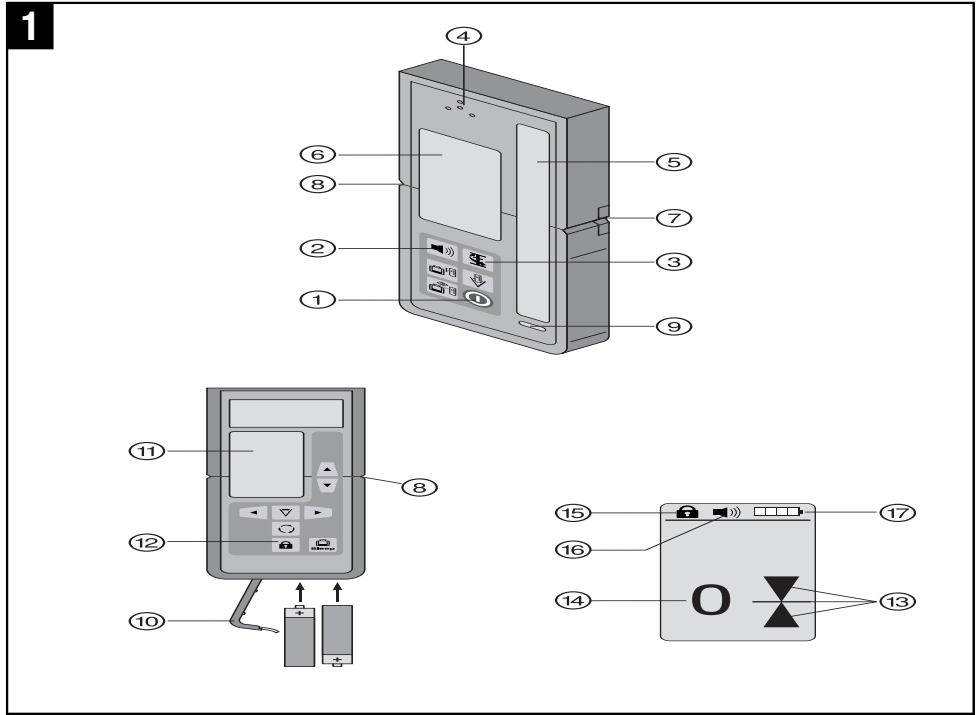

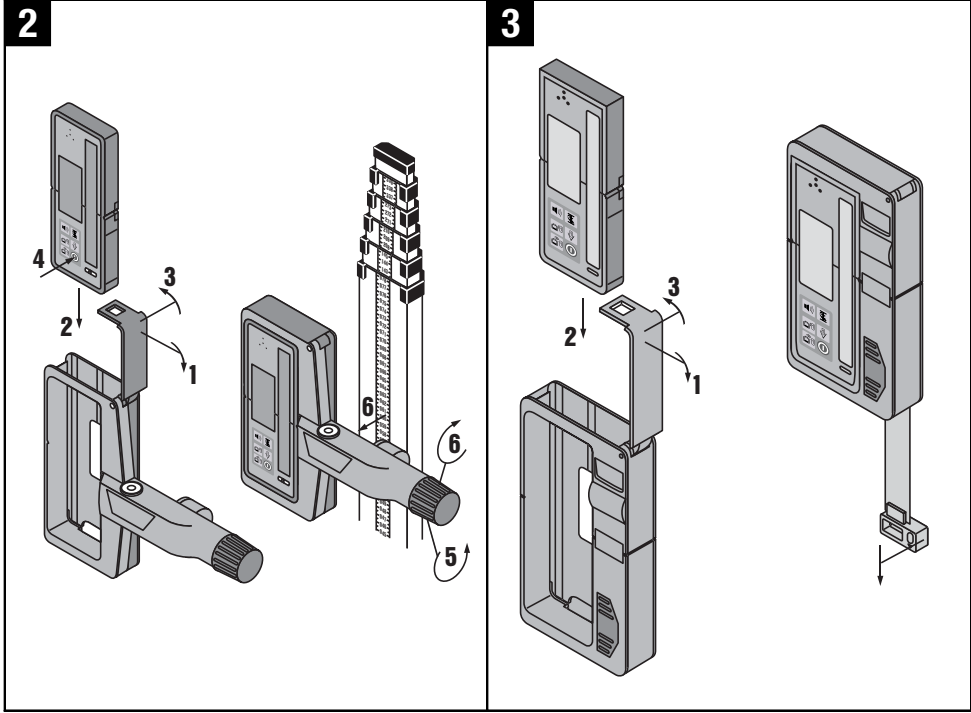



ORIGINAL OPERATING INSTRUCTIONS

PRA 35 remote control / laser receiver

en

It is essential that the operating instructions are read before the tool is operated for the first time.

Always keep these operating instructions together with the tool.

Ensure that the operating instructions are with the tool when it is given to other persons.

Contents	Page
1. General information	1
2. Description	2
3. Technical data	3
4. Safety instructions	4
5. Before use	5
6. Operation	5
7. Care and maintenance	6
8. Disposal	6
9. Manufacturer's warranty - tools	7
10. FCC statement (applicable in USA)	7
11. EC declaration of conformity	8

1 These numbers refer to the corresponding illustrations. The illustrations can be found on the fold-out

cover pages. Keep these pages open while studying the operating instructions.

In these operating instructions, the designation "the tool" always refers to the PRA 35 laser receiver.

Parts, operating controls and indicators **1**

PRA 35 remote control / laser receiver

- ① On/off button
- ② Signal tone button
- ③ Units button
- ④ Signal tone aperture
- ⑤ Receiving area
- ⑥ Display area, front
- ⑦ Marking notch
- ⑧ Reference plane
- ⑨ Bubble level
- ⑩ Battery compartment cover
- ⑪ Display area, rear
- ⑫ Button lock

PRA 35 laser receiver display

- ⑬ Display showing the position of the receiver relative to the height of the laser plane
- ⑭ Exact distance of the receiver from the laser plane
- ⑮ Button lock
- ⑯ Volume
- ⑰ Battery status indicator

1. General information

1.1 Safety notices and their meaning

DANGER

Draws attention to imminent danger that could lead to serious bodily injury or fatality.

WARNING

Draws attention to a potentially dangerous situation that could lead to serious personal injury or fatality.

CAUTION

Draws attention to a potentially dangerous situation that could lead to slight personal injury or damage to the equipment or other property.

NOTE

Draws attention to an instruction or other useful information.

1.2 Explanation of the pictograms and other information

Warning signs

en



General warning

Symbols



Read the operating instructions before use



Return waste material for recycling.

Location of identification data on the tool

The type designation and serial number can be found on the type identification plate on the tool. Make a note of this data in your operating instructions and always refer to it when making an enquiry to your Hilti representative or service department.

Type: _____

Generation: 01 _____

Serial no.: _____

2. Description

2.1 Use of the product as directed

The Hilti PRA 35 can be used to remotely control the PR 35 rotating laser and to detect and locate the laser beam. These operating instructions apply only to operation of the PRA 35 laser receiver. For information about the remote control functions, please refer to the operating instructions for the PR 35.

In conjunction with the PR 35, the tool can be used to determine, transfer and check horizontal levels and heights, verticals, inclined planes and right angles, e.g. transferring datums and height marks, determining or checking right angles for walls, vertical alignment from a reference point and setting out slopes.

Observe the information printed in the operating instructions concerning operation, care and maintenance.

Take the influences of the surrounding area into account. Do not use the tool where there is a risk of fire or explosion.

Modification of the tool or tampering with its parts is not permissible.

2.2 Features

The tool can be held by hand or mounted on a leveling staff, timber batten or frame etc., using the applicable holder.

2.3 Indicators

NOTE

The display of the PRA 35 laser receiver uses several symbols to indicate various modes or statuses.

Indication of the position of the receiver relative to the laser plane

The position of the receiver relative to the laser plane is shown by an arrow indicating the direction in which the receiver has to be moved in order to bring it exactly into alignment with the laser.

Battery status indicator

The battery status indicator shows the remaining battery capacity.

Volume level	When no volume level symbol is visible in the display, the volume level is set to zero (off). If 1 column is shown, the volume is set to "quiet". If 2 columns are shown, the volume is set to "normal". If 3 columns are shown, the volume is set to "loud".
Offset indicator	Shows the exact distance of the receiver from the laser plane in the desired measuring units.
Other indicators	Other indicators in the display refer to the PR 35 rotating laser when controlled remotely. For further information, please refer to the PR 35 operating instructions.

en

2.4 Items supplied

- 1 PRA 35 remote control / laser receiver
- 1 PRA 35 operating instructions
- 2 Batteries
- 1 Manufacturer's certificate

3. Technical data

Right of technical changes reserved.

Detection range (area diameter)	2...300 m (6 to 1000 ft)
Signal tone generator	3 volume levels plus mute setting
Liquid crystal display	On both sides
Indicator range, distance from zero	± 50 mm (± 2 in)
Laser plane indication area	± 0.5 mm (± 0.02 in)
Width of receiving area	120 mm (5 in)
Center indication from top edge of casing	75 mm (3 in)
Marking notches	On both sides
Automatic power-off	When no beam is detected: 15 min
Dimensions	160 mm X 67 mm X 24 mm
Weight (including batteries)	0.25 kg (0.6 lbs)
Power source	2 AA-size batteries
Battery life (alkaline-manganese)	Temperature +20°C (+68 °F): 40 h
Operating temperature range	-20...+50°C (-4°F to 122°F)
Storage temperature	-25...+60°C (-13 °F to 140 °F)
Protection class	IP 56 in accordance with IEC 529

4. Safety instructions

4.1 Basic information concerning safety

en

In addition to the information relevant to safety given in each of the sections of these operating instructions, the following points must be strictly observed at all times.

4.2 General safety rules

- a) Keep other persons, especially children, away from the area in which the work is being carried out.
- b) Check the condition of the tool before use. If the tool is found to be damaged, have it repaired at a Hilti service center.
- c) Have the tool repaired only at a Hilti service center.
- d) Do not render safety devices ineffective and do not remove information and warning notices.
- e) The tool must be checked at a Hilti service center after it has been dropped or subjected to other mechanical stresses.
- f) If mounting on an adapter, check that the tool is fitted correctly.
- g) To avoid measurement errors, the receiving area must be kept clean.
- h) Although the tool is designed for the tough conditions of jobsite use, as with other optical and electronic instruments (e.g. binoculars, spectacles, cameras) it should be treated with care.
- i) Although the tool is protected to prevent entry of dampness, it should be wiped dry each time before being put away in its transport container.
- j) To avoid hearing damage, hold the tool as far away as possible from your ear (and other persons' ears).

4.2.1 Electrical



- a) Keep the batteries out of reach of children.

- b) Do not allow the batteries to overheat and do not expose them to fire. The batteries may explode or release toxic substances.
- c) Do not charge the batteries.
- d) Do not solder the batteries into the tool.
- e) Do not discharge the batteries by short circuiting as this may cause them to overheat and present a risk of personal injury (burns).
- f) Do not attempt to open the batteries and do not subject them to excessive mechanical stress.

4.3 Proper organization of the work area

- a) Avoid unfavorable body positions when working on ladders or scaffolding. Make sure you work from a safe stance and stay in balance at all times.
- b) Use the tool only within its specified limits.
- c) Measurements taken through or from panes of glass or through other objects may be inaccurate.
- d) Use of the telescopic staff in the vicinity of overhead high voltage cables is not permissible.
- e) Reflection of the laser beam from glass or other reflective surfaces may cause errors or incorrect results.

4.4 Electromagnetic compatibility

Although the tool complies with the strict requirements of the applicable directives, Hilti cannot entirely rule out the possibility of the tool being subject to interference caused by powerful electromagnetic radiation, leading to incorrect operation. Check the accuracy of the tool by taking measurements by other means when working under such conditions or if you are unsure. Likewise, Hilti cannot rule out the possibility of interference with other devices (e.g. aircraft navigation equipment).

5. Before use



5.1 Inserting the batteries **1**

CAUTION

Do not use damaged batteries.

DANGER

Do not mix old and new batteries. Do not mix batteries of different makes or types.

en

NOTE

Only batteries recommended by Hilti may be used to power the tool.

6. Operation



6.1 Switching the tool off and on **1**

Press the "On/off" button.

Check to ensure that the button lock on the receiver side is deactivated. Deactivation is indicated by the open lock symbol in the display.

Please note that all remote control buttons on the PRA 35 function only in conjunction with a PR 35 rotating laser. For information about the button functions, please refer to the PR 35 operating instructions.

6.2 Working with the tool

The PRA 35 laser receiver can be used at distances (radiuses) of up to 150m (500ft). The laser beam is indicated visually and by a signal tone.

6.2.1 Using the laser receiver as a hand-held tool

1. Press the "On/off" button.
2. Hold the PRA 35 in the plane of the rotating laser beam.
The laser beam is indicated by visual and audible signals.

6.2.2 Working with the laser receiver in the PRA 80 receiver holder **2**

1. Open the catch on the PRA 80.
2. Place the PRA 35 in the PRA 80 receiver holder.
3. Close the catch on the PRA 80.
4. Switch the PRA 35 on by pressing the "On/off" button.
5. Rotate the grip to bring it into the open position.

6. Secure the PRA 80 receiver holder on the telescopic staff or leveling staff by turning the rotating grip.
7. Hold the PRA 35 with the receiving window directly in the plane of the rotating laser beam. The laser beam is indicated by visual and audible signals.

6.2.3 Working with the PRA 81 **3**

1. Open the locking mechanism on the PRA 81.
2. Insert the PRA 35 laser receiver in the PRA 81 height transfer device.
3. Close the locking mechanism on the PRA 81.
4. Switch the PRA 35 on by pressing the "On/off" button.
5. Position the PRA 35 so that the distance display shows "0".
6. Hold the PRA 35 with the receiving window directly in the plane of the rotating laser beam.
7. Use the measuring tape to measure the desired offset distance.

6.2.4 Menu options

When switching the PRA 35 on, press and hold the "On/off" button for two seconds.

The menu is then shown in the display.

Use the "Units" button to switch between metric and imperial units.

Use the "Volume" button to assign the more rapid signal tone to the upper or lower area of the receiving window.

To save the settings, switch the PRA 35 off.

6.2.5 Setting the measuring unit

The “Units” button can be used to set the desired measuring unit according to the country of use (mm / cm / off) or ($\frac{1}{16}$ in / $\frac{1}{4}$ in / off).

6.2.6 Setting the volume of the signal tone

The tool is set to “Normal” volume when switched on. The volume can be adjusted by pressing the “Signal tone” button. One of the following settings can be selected: “Low”, “Normal”, “High” or “Off”.

en

7. Care and maintenance

7.1 Cleaning and drying

1. Blow dust off the surfaces.
2. Do not touch the display areas or the receiving window with the fingers.
3. Use only a clean, soft cloth for cleaning. If necessary, moisten the cloth slightly with pure alcohol or a little water.
NOTE Do not use any other liquids as these may damage the plastic components.
4. Observe the temperature limits when storing your equipment. This is particularly important in winter / summer if the equipment is kept inside a motor vehicle (25°C to +60°C / -13°F to +140°F).

7.2 Storage

Remove the tool from its case if it has become wet. The tool, its carrying case and accessories should be cleaned and dried (at maximum 40°C / 104°F). Repack the equipment only once it has dried completely and then store it in a dry place.

Check the accuracy of the equipment before it is used after a long period of storage or transportation.

Remove the batteries from the tool before storing it for a long period. Leaking batteries may damage the tool.

7.3 Transport

Use the Hilti toolbox or packaging of equivalent quality for transporting or shipping your equipment.

DANGER

Always remove the batteries before transporting the tool.

7.4 Hilti calibration service

We recommend that the tool is checked by the Hilti calibration service at regular intervals in order to verify its reliability in accordance with standards and legal requirements.

Use can be made of the Hilti calibration service at any time, but checking at least once a year is recommended.

The calibration service provides confirmation that the tool is in conformance, on the day it is checked, with the specifications given in the operating instructions. The tool will be readjusted if deviations from the manufacturer’s specification are found. After checking and adjustment, a calibration sticker applied to the tool and a calibration certificate provide written verification that the tool operates in accordance with the manufacturer’s specification.

Calibration certificates are always required by companies certified according to ISO 900x.

Your local Hilti Center or representative will be pleased to provide further information.

8. Disposal

DANGER

Improper disposal of the equipment may have serious consequences:

The burning of plastic components generates toxic fumes which may present a health hazard.

Batteries may explode if damaged or exposed to very high temperatures, causing poisoning, burns, acid burns or environmental pollution.

Careless disposal may permit unauthorized and improper use of the equipment. This may result in serious personal injury, injury to third parties and pollution of the environment.



Most of the materials from which Hilti tools or appliances are manufactured can be recycled. The materials must be correctly separated before they can be recycled. In many countries, Hilti has already made arrangements for taking back old tools and appliances for recycling. Ask Hilti customer service or your Hilti representative for further information.

en



For EC countries only

Disposal of electric appliances together with household waste is not permissible.

In observance of European Directive 2002/96/EC on waste electrical and electronic equipment and its implementation in accordance with national law, electric tools that have reached the end of their life must be collected separately and returned to an environmentally compatible recycling facility.



Dispose of the batteries in accordance with national regulations.

9. Manufacturer's warranty - tools

Hilti warrants that the tool supplied is free of defects in material and workmanship. This warranty is valid so long as the tool is operated and handled correctly, cleaned and serviced properly and in accordance with the Hilti Operating Instructions, and the technical system is maintained. This means that only original Hilti consumables, components and spare parts may be used in the tool.

This warranty provides the free-of-charge repair or replacement of defective parts only over the entire lifespan of the tool. Parts requiring repair or replacement as a result of normal wear and tear are not covered by this warranty.

Additional claims are excluded, unless stringent national rules prohibit such exclusion. In particular, Hilti is not obligated for direct, indirect, incidental or consequential damages, losses or expenses in connection with, or by reason of, the use of, or inability to use the tool for any purpose. Implied warranties of merchantability or fitness for a particular purpose are specifically excluded.

For repair or replacement, send the tool or related parts immediately upon discovery of the defect to the address of the local Hilti marketing organization provided.

This constitutes Hilti's entire obligation with regard to warranty and supersedes all prior or contemporaneous comments and oral or written agreements concerning warranties.

10. FCC statement (applicable in USA)

CAUTION

This equipment has been tested and found to comply with the limits for a class B digital device, pursuant to part 15 of the FCC rules. These limits are designed to provide reasonable protection against harmful interference in a residential installation. This equipment

generates, uses, and can radiate radiofrequency energy and, if not installed and used in accordance with the instructions, may cause harmful interference to radio communications.

en

However, there is no guarantee that interference will not occur in a particular installation. If this equipment does cause harmful interference to radio or television reception, which can be determined by turning the equipment on and off, the user is encouraged to try to correct the interference by one or more of the following measures:

Re-orient or relocate the receiving antenna.

Increase the distance between the equipment and receiver.

Consult the dealer or an experienced TV/radio technician for assistance.

NOTE

Changes or modifications not expressly approved by the party responsible for compliance could void the user's authority to operate the equipment.

This device complies with Part 15 of the FCC Rules and RSS-210 of IC. Operation is subject to the following two conditions: (1) this device may not cause harmful interference, and (2) this device must accept any interference received, including interference that may cause undesired operation.

11. EC declaration of conformity

Designation:	Remote control / laser receiver
Type:	PRA 35
Year of design:	2010

We declare, on our sole responsibility, that this product complies with the following directives and standards: 2004/108/EC, 2006/42/EC, EN 300 440-2, EN 301 489-3 V1.4.1, EN 55014-1, EN 55014-2, EN 61000-3-2, EN 61000-3-3.

Hilti Corporation



Dietmar Sartor
Head of BA Quality and Process
Management
Business Area Electric Tools & Accessories
04 2010



Tassilo Deinzer
Head BU Measuring Systems
BU Measuring Systems
04 2010