

---

## EWLAN1 integration manual

The EWLAN1 Module is a 3x3 3-stream IEEE 802.11 a/b/g/n wireless LAN module in PCI express mini card form factor, designed to deliver high-reliable radio performance for a variety of bandwidth-intensive wireless applications.

### Outer Appearance

Top view with Samtec connector (PCI express):

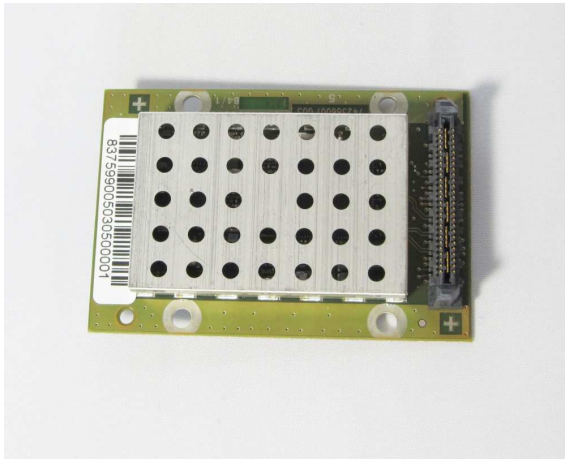

Rear view with antenna connectors:

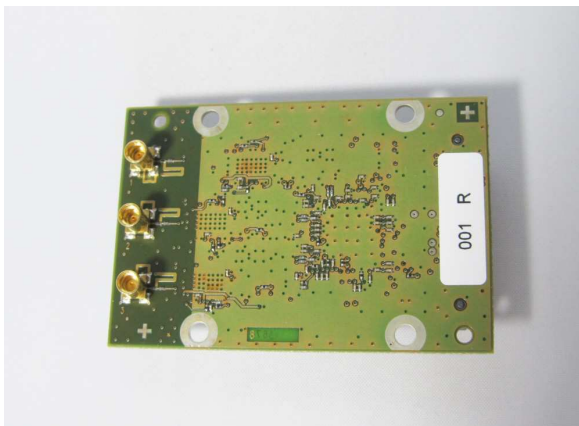

### Dimensions:

34 mm (w) x 54mm (l) x 10 mm (h)

---

### **General requirements:**

This module is designed exclusively for usage in Hirschmann (Belden) host equipment. A regulated power supply via the dedicated interface to the WLAN module is required.

This RF module is approved only for use in products operating as fixed or mobile transmitting device where the antennas are at least 50 cm away from any persons during normal operating conditions.

Changes or modifications not expressly approved by the party responsible for compliance could void the user's authority to operate the equipment.

The integrator is still responsible for the FCC compliance requirement of the end product, which integrates this module.

Appropriate measurements (e.g. 15 B compliance) and if applicable additional equipment authorizations (e.g. Verification , Doc) of the host device to be addressed by the integrator/manufacturer.

### **Hardware Integration**

EWLAN1 supports the PCI express standard from the electrical power supply and signaling point of view. To enhance connection reliability in harsh environments between EWLAN1 and the host equipment, Samtec interface connectors have been selected.

EWLAN1 is equipped with Samtec connector QRM8

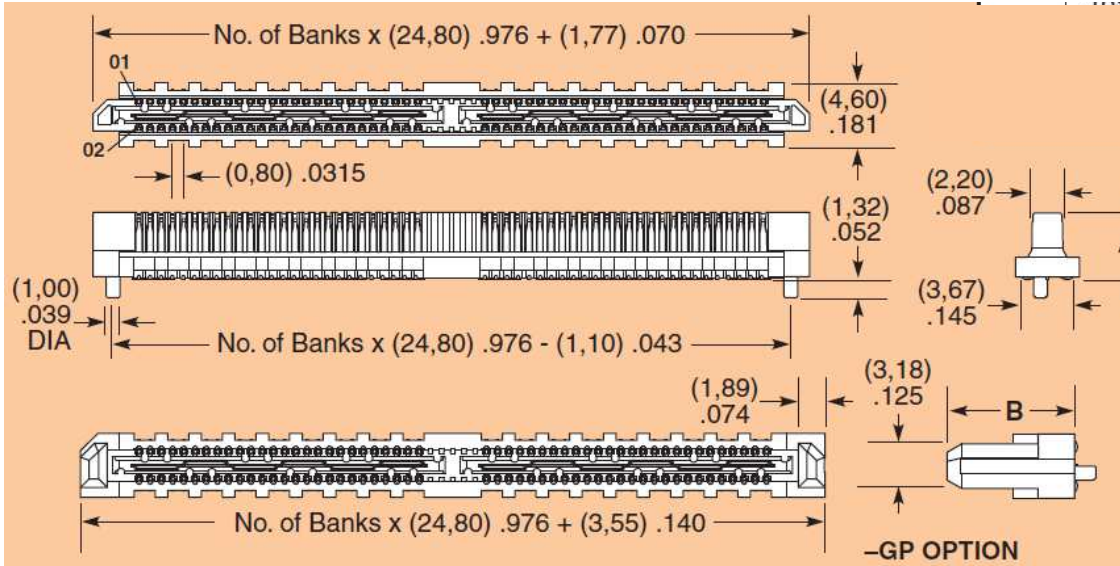

The host equipment has to be equipped with Samtec connector QRF8-026-05.0-L-D-A-GP

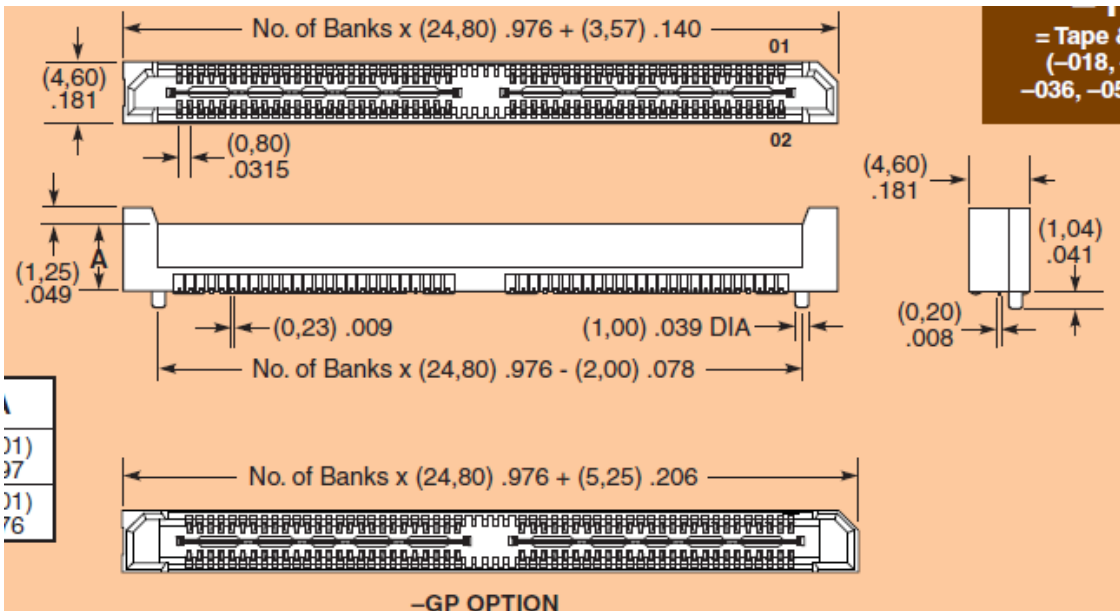

Pin assignment of QRF8-026-05.0-L-D-A-GP

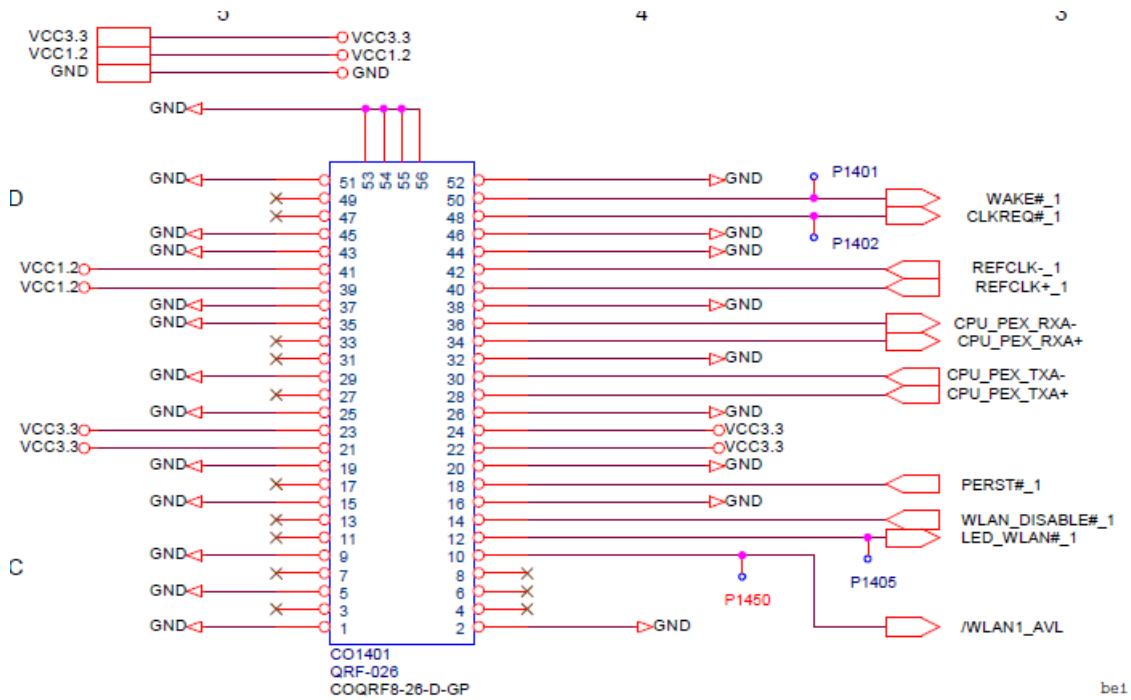

### Data Interface Pin definition

Pin	Signal	Comment	Pin	Signal	Comment
1	GND	ground	2	GND	ground
3	Res	open	4	Res	open
5	GND	ground	6	Res	open
7	Res	open	8	Res	open
9	GND	ground	10	Res	open
11	Res	open	12	GPIO10	GPIO-Interface
13	Res	open	14	GPIO7	GPIO-Interface
15	GND	ground	16	GND	ground
17	Res	open	18	PERST_L	/Reset
19	GND	ground	20	GND	ground
21	VCC3.3	3.3V ±5%	22	VCC3.3	3.3V ±5%
23	VCC3.3	3.3V ±5%	24	VCC3.3	3.3V ±5%
25	GND	ground	26	GND	ground
27	Res	open	28	PETp0	PCIe Tx+
29	GND	ground	30	PETn0	PCIe Tx-
31	Res	open	32	GND	ground
33	Res	open	34	PERp0	PCIe Rx+
35	GND	ground	36	PERn0	PCIe Rx-
37	GND	ground	38	GND	ground

**Integration Information**  
FCC ID: U99EWLAN1  
IC: 4019A-EWLAN1



---

<b>39</b>	VCC1.2	1.2V ±5%	<b>40</b>	REFCLK+	PCle Ref Clock+
<b>41</b>	VCC1.2	1.2V ±5%	<b>42</b>	REFCLK-	PCle Ref Clock-
<b>43</b>	GND	ground	<b>44</b>	GND	ground
<b>45</b>	GND	ground	<b>46</b>	GND	ground
<b>47</b>	Res	open	<b>48</b>	CLKreq_L	/Clock request
<b>49</b>	Res	open	<b>50</b>	WAKE_L	/PCle awake
<b>51</b>	GND	ground	<b>52</b>	GND	ground

---

## Power Requirements

ELWAN1 has to be powered as follows:  
3.3VDC at VCC3.3  
1.28VDC at VCC1.2

## Antenna Connectors

The antenna connectors of EWLAN1 are micro miniature coaxial types (MMCX).

## Antennas (USA/Canada)

The usage of the antennas for products shipped to North America (USA and Canada) is restricted to the models and bands below:

Antennas operating with this device model (Hirschmann model names)	Permitted band of operation		
	2.4 GHz Band	5.15-5.25 GHz Band	5.725-5.825 GHz Band
BAT-ANT-RSMA-2AGN-R	Yes	Yes	Yes
BAT-ANT-N-3AGN-IP67	Yes	Yes	Yes
BAT-ANT-N-MiMoDB-5N-IP65	Yes	Yes	Yes
BAT-ANT-N-MiMo5-9N-IP65	No	Yes	Yes
BAT-ANT-N-8G-DS-IP65	Yes	No	No

## SW Integration

EWLAN1 is designed for usage with Hirschmann host equipment (motherboards) running the HiLCOS operating system 8.60.x or higher versions.

Only HiLCOS versions with fixed (non-adjustable) radio parameters for USA/Canada are allowed for products intended for the North American market.

---

## Regulatory Requirements (FCC/IC)

If intended for the North American market the following regulatory requirements apply:

- 1) ELWAN1 needs to be labeled with the FCC ID and Canada number:  
**FCC ID: U99EWLAN1**  
**IC: 4019A-EWLAN1**
  
- 2) The host product need to be labeled as below:

This device complies with Part 15 of the FCC Rules and Industry Canada licence-exempt RSS standard(s).  
Operation is subject to the following two conditions:  
(1) this device may not cause harmful interference, and  
(2) this device must accept any interference received, including interference that may cause undesired operation.  
CAN ICES-3 (B)/NMB-3(B)

Contains Transmitter Module  
FCC ID: U99EWLAN1  
IC: 4019A-EWLAN1

- 3) **The user guide of the host equipment shall contain the following information:**

### FCC note:

This device complies with part 15 of the FCC rules. Operation is subject to the following two conditions:

- ▶ This device may not cause harmful interference, and
- ▶ This device must accept any interference received, including interference that may cause undesired operation.

**Note:** This equipment has been tested and found to comply with the limits for a Class B digital device, pursuant to part 15 of the FCC Rules. These limits are designed to provide reasonable protection against harmful interference in a residential installation. This equipment generates, uses and can radiate radio frequency energy and, if not installed and used in accordance with the instructions, may cause harmful interference to radio communications. However, there is no guarantee that interference will not occur in a particular installation. If this equipment does cause harmful interference to radio or television reception, which can be determined by turning the equipment off and on, the user is encouraged to try to correct the interference by one or more of the following measures:

- Reorient or relocate the receiving antenna.
- Increase the separation between the equipment and receiver.

- Connect the equipment into an outlet on a circuit different from that to which the receiver is connected.
- Consult the dealer or an experienced radio/TV technician for help.

Changes or modifications not expressly approved by the party responsible for compliance could void the user's authority to operate the equipment.

**Note:** The following paragraph is valid for devices labeled with FCC ID: U99EWLAN1 and IC: 4019A-EWLAN1:

**Important note:** This equipment complies with FCC and IC RSS-102 radiation exposure limits set forth for an uncontrolled environment. This equipment should be installed and operated with minimum distance 50 cm (19.7 in, applied to a 9 dBi antenna) between the radiator and your body. The antenna used for this transmitter must not be co-located with any other transmitters within a host device, except in accordance with FCC multi-transmitter product procedures.

This transmitter is restricted to indoor use only within the 5.15-5.25 GHz band to reduce potential for harmful interference to co-channel mobile satellite systems.

This Class B digital apparatus complies with Canadian ICES-003. Cet appareil numérique de la classe B est conforme à la norme NMB-003 du Canada. To reduce potential radio interference to other users, the antenna type and its gain should be so chosen that the equivalent isotropically radiated power (EIRP) is not more than that permitted for successful communication.

This device has been designed to operate with the antennas listed below in point-to-multipoint systems, and having a maximum gain of 9 dBi:

Antennas operating with this device model:	Permitted band of operation		
	2.4 GHz Band	5.15-5.25 GHz Band	5.725-5.825 GHz Band
<b>BAT-ANT-RSMA-2AGN-R</b> <sup>(1)</sup>	Yes	Yes	Yes
<b>BAT-ANT-N-3AGN-IP67</b>	Yes	Yes	Yes
<b>BAT-ANT-N-MiMoDB-5N-IP65</b>	Yes	Yes	Yes
<b>BAT-ANT-N-MiMo5-9N-IP65</b>	No	Yes	Yes
<b>BAT-ANT-N-8G-DS-IP65</b>	Yes	No	No

Antennas not included in this list are prohibited for use with this device. The required antenna impedance is 50 ohms.

Note (1): When using three antennas of the type BAT-ANT-RSMA-2AGN-R, each antenna has to be aligned into a separate spatial direction (x-y-z), where one antenna is perpendicular to the device and the other two are at right angles to each other.