



HIRSCHMANN

A **BELDEN** BRAND

User Manual

Installation

Open Dual-Band Industrial Access-Point / Client / Access-Bridge

OpenBAT-Family: BAT-F

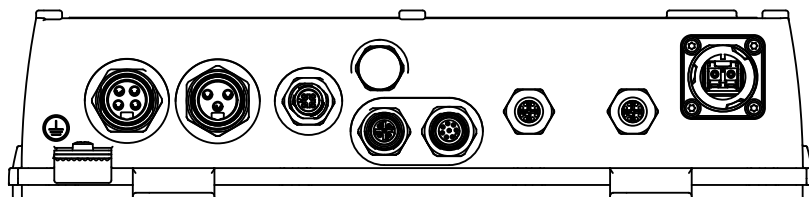
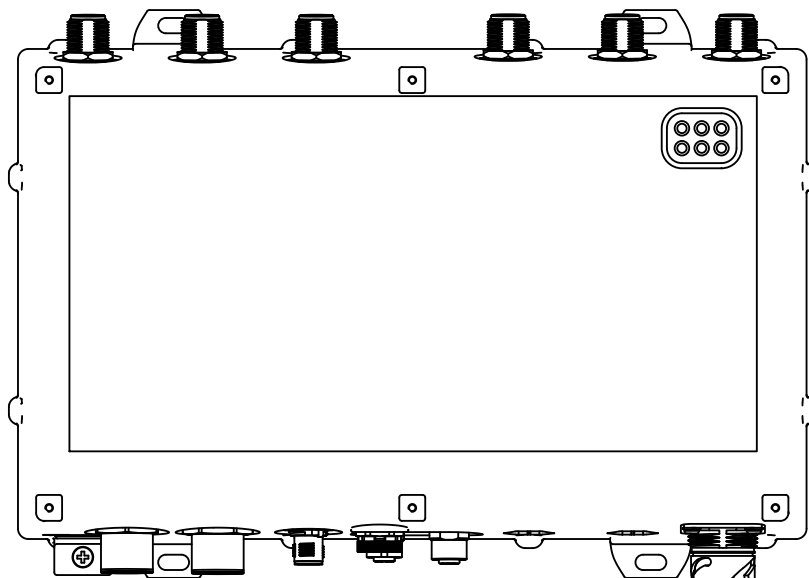

The naming of copyrighted trademarks in this manual, even when not specially indicated, should not be taken to mean that these names may be considered as free in the sense of the trademark and tradename protection law and hence that they may be freely used by anyone.

© 2020 Hirschmann Automation and Control GmbH

Manuals and software are protected by copyright. All rights reserved. The copying, reproduction, translation, conversion into any electronic medium or machine scannable form is not permitted, either in whole or in part. An exception is the preparation of a backup copy of the software for your own use.

The performance features described here are binding only if they have been expressly agreed when the contract was made. This document was produced by Hirschmann Automation and Control GmbH according to the best of the company's knowledge. Hirschmann reserves the right to change the contents of this document without prior notice. Hirschmann can give no guarantee in respect of the correctness or accuracy of the information in this document.

Hirschmann can accept no responsibility for damages, resulting from the use of the network components or the associated operating software. In addition, we refer to the conditions of use specified in the license contract.

You can get the latest version of this manual on the Internet at the Hirschmann product site (www.hirschmann.com).

Hirschmann Automation and Control GmbH
Stuttgarter Str. 45-51
72654 Neckartenzlingen
Germany

Contents

Safety instructions	7
About this manual	24
Key	25
1 Description	26
1.1 General description	26
1.2 Device name and product code	27
1.3 Device view	31
1.4 Power supply	33
1.4.1 Supply voltage with the characteristic value C (24 V DC ... 48 V DC)	33
1.4.2 Supply voltage with the characteristic value K (60 V DC ... 250 V DC / 110 V AC ... 230 V AC, 50 Hz ... 60 Hz)	33
1.4.3 Supply voltage with the characteristic value P (Power supply only through PoE)	33
1.4.4 Supply voltage with the characteristic value W (24 V DC)	34
1.5 Ethernet ports	34
1.5.1 Gigabit combo port	34
1.5.2 10/100/1000 Mbit/s twisted-pair connection (optional)	35
1.5.3 Pin assignments	35
1.6 Connections for antennas	37
1.7 Display elements	37
1.7.1 Meaning of the LEDs	37
1.7.2 Device state	38
1.7.3 Port status	38
1.8 Management interfaces	39
1.8.1 V.24 interface (external management)	39
1.8.2 USB interface	41
1.9 Signal contact	41
1.10 Reset button	41

2	Installation	43
2.1	Checking the package contents	43
2.2	Installing and grounding the device	43
2.2.1	Installing the device onto or on a flat surface	43
2.2.2	Installing the device on a pole	44
2.2.3	Grounding the device	44
2.3	Installing an SFP transceiver (optional)	45
2.4	Installing the antennas	45
2.5	Connecting the power supply and the signal contact lines	46
2.5.1	Supply voltage with the characteristic value C (24 V DC ... 48 V DC)	47
2.5.2	Supply voltage with the characteristic value K (60 V DC ... 250 V DC / 110 V AC ... 230 V AC, 50 Hz ... 60 Hz)	47
2.5.3	Supply voltage with the characteristic value W (24 V DC)	48
2.5.4	Signal contact	49
2.6	Operating the device	49
2.6.1	Connecting the power supply through a 7/8" connector	50
2.6.2	Connecting the power supply through PoE	50
2.7	Connecting data cables	50
2.7.1	Gigabit combo port	50
2.7.2	10/100/1000 Mbit/s twisted-pair connection (optional)	51
3	Making basic settings	52
4	First login (Password change)	53
5	Obtain compliance for operation in the European Union	54
6	Configuring the transmit power	57
7	Configuring the transmit power for the 4.9 GHz band	59
8	Maintenance and service	61

9	Disassembly	62
9.1	Removing the device	62
9.2	Removing an SFP transceiver (optional)	62
10	Technical data	63
10.1	General technical data	63
10.2	Dimension drawings	65
10.3	Radio technology	68
10.4	Roaming	68
10.5	Receiving sensitivity, transmit power, and data rate of the WLAN module version EWLAN1 (Approvals 2, characteristic value M or 9)	69
10.5.1	IEEE 802.11b	69
10.5.2	IEEE 802.11g	69
10.5.3	IEEE 802.11a	70
10.5.4	IEEE 802.11n	70
10.6	Receiving sensitivity, transmit power, and data rate of the WLAN module version EWLAN1 for device variants with approval for the 4.9 GHz band (Approvals 2, characteristic value P)	73
10.6.1	IEEE 802.11a, Bandwidth 5 MHz	73
10.6.2	IEEE 802.11a, Bandwidth 10 MHz	73
10.6.3	IEEE 802.11a, Bandwidth 20 MHz	74
10.7	Receiving sensitivity, transmit power, and data rate of the WLAN module version EWLAN2 for high-gain antennas (Approvals 2, characteristic value H)	75
10.7.1	IEEE 802.11b	75
10.7.2	IEEE 802.11g	75
10.7.3	IEEE 802.11a	76
10.7.4	IEEE 802.11n	76
10.8	EMC and immunity	78
10.9	Network range	79
10.10	Power consumption/power output	80
11	Scope of delivery, order numbers and accessories	81

12	Underlying technical standards	84
A	Further support	86

Safety instructions

WARNING

UNCONTROLLED MACHINE ACTIONS

To avoid uncontrolled machine actions caused by data loss, configure all the data transmission devices individually.

Before you start any machine which is controlled via data transmission, be sure to complete the configuration of all data transmission devices.

Failure to follow this instruction can result in death, serious injury, or equipment damage.

■ **General safety instructions**

You operate this device with electricity. Improper usage of the device entails the risk of physical injury or significant property damage. The proper and safe operation of this device depends on proper handling during transportation, proper storage and installation, and careful operation and maintenance procedures.

- Before connecting any cable, read this document, and the safety instructions and warnings.
- Operate the device with undamaged components exclusively.
- The device is free of any service components. In case of a damaged or malfunctioning device, turn off the supply voltage and return the device to Hirschmann for inspection.
- Internal fuses are triggered only in the case of a detected error in the device. In case of damage or malfunction of the device, turn off the supply voltage and return the device to the plant for inspection.

■ **Certified usage**

- Use the product only for the application cases described in the Hirschmann product information, including this manual.
- Operate the product only according to the technical specifications. [See “Technical data” on page 63.](#)
- Connect to the product only components suitable for the requirements of the specific application case.

■ **Installation site requirements**

Restricted access location:

- ▶ The location is outside the operator access area.
- ▶ The location is accessible to the service personnel even when the device is switched on.

Indoor operator access area:

- ▶ The location is accessible without tools.
- ▶ The person responsible for the area has provided access for the operator intentionally.
- ▶ The operator knows of the access possibilities, regardless of whether they need a tool.

If **all** the following requirements are fulfilled, you have the option of installing the device in the indoor operator access area.

- ▶ You supply 24 V DC to 48 V DC SELV voltage to the device.
- ▶ You install the device inside a building.
- ▶ The surrounding air temperature is ≤ 140 °F (60 °C).
- ▶ Applies exclusively for Finland, Norway, and Sweden:
You supply Power over Ethernet (PoE) to the device, with the PoE data cable laid inside a building exclusively.

In any case, install this device in a switch cabinet or in an operating site with restricted access, to which maintenance staff have exclusive access if **1** of the following requirements is fulfilled:

- ▶ You supply 60 V DC to 250 V DC or 110 V AC to 230 V AC to the device.
- ▶ You install the device outside a building.
- ▶ The surrounding air temperature is > 140 °F (60 °C).
- ▶ Applies exclusively for Finland, Norway, and Sweden:
You supply Power over Ethernet (PoE) to the device, with the PoE data cable laid outside a building or between buildings.

Applies to device variants featuring supply voltage with characteristic value K: (60 V DC ... 250 V DC / 110 V AC ... 230 V AC, 50 Hz ... 60 Hz):

[See “Device name and product code” on page 27.](#)

Install this device only in a switch cabinet or in an operating site with restricted access, to which maintenance staff have exclusive access.

■ **Device casing**

Only technicians authorized by the manufacturer are permitted to open the casing.

- Install the device in the vertical position, with the antenna connections pointing upwards.
- At ambient air temperatures > 140 °F (+60 °C):
The surfaces of the device housing may become hot. Avoid touching the device while it is operating.

■ **Qualification requirements for personnel**

- Only allow qualified personnel to work on the device.

Qualified personnel have the following characteristics:

- ▶ Qualified personnel are properly trained. Training as well as practical knowledge and experience make up their qualifications. This is the prerequisite for grounding and labeling circuits, devices, and systems in accordance with current standards in safety technology.
- ▶ Qualified personnel are aware of the dangers that exist in their work.
- ▶ Qualified personnel are familiar with appropriate measures against these hazards in order to reduce the risk for themselves and others.
- ▶ Qualified personnel receive training on a regular basis.

■ **National and international safety regulations**

- Verify that the electrical installation meets local or nationally applicable safety regulations.
- When installing antennas, observe the regulations of the country in which you are operating the WLAN device with regard to the general operating permission and the maximum emission levels.
- Install and operate this equipment with a minimum distance of 19.7 inches (50 cm) between the antenna and your body.

■ **Grounding the device**

Grounding the device is by means of a separate ground connection on the device.

- Ground the device before connecting any other cables.
- Disconnect the grounding only after disconnecting all other cables.

The overall shield of a connected shielded twisted pair cable is connected to the ground connection on the metal housing as a conductor.

■ **Lightning protection**

- Refer to the information in the “WLAN Outdoor Guide” on “Lightning and overvoltage protection”.
The manual is available for download on the Internet: <https://www.doc.hirschmann.com>
- Install over voltage protector devices on every outdoor Ethernet cable.
- Protect antennas installed outside with lightning protection devices (for example lightning conductors).
- Take lightning protection measures which mitigate the effects of lightning strikes.
- ▶ The installation of the device occurs in accordance with valid standards (such as IEC 62305 / DIN EN 62305 (VDE 0185-305)), and in accordance with the lightning protection procedures recognized and proven for the application and the environment.

■ Requirements for connecting electrical wires

Before connecting the electrical wires, **always** verify that the requirements listed are complied with.

The following requirements apply without restrictions:

- ▶ The electrical wires are voltage-free.
- ▶ The cables used are permitted for the temperature range of the application case.
- ▶ Relevant for North America:
The power supply cables are suitable for ambient air temperatures of at least 167 °F (75 °C). The power supply cable wires are made of copper.

Table 1: *Requirements for connecting electrical wires*

■ Requirements for connecting the supply voltage

The following requirements apply without restrictions:

All variants	All of the following requirements are complied with: <ul style="list-style-type: none">▶ The supply voltage corresponds to the voltage specified on the type plate of the device.▶ The power supply conforms to overvoltage category I or II.▶ The power supply has an easily accessible disconnecting device (for example a switch or a plug). This disconnecting device is clearly identified. So in the case of an emergency, it is clear which disconnecting device belongs to which power supply cable.▶ The cross-section of the ground conductor is the same size as or bigger than the cross-section of the power supply cables.
---------------------	--

Table 2: *Requirements for connecting the supply voltage*

The following requirements apply without restrictions:

Only for device variants featuring supply voltage with characteristic value C (24 V DC ... 48 V DC) or W (24 V DC):	The wire diameter of the power supply cable is at least 1 mm ² (North America: AWG16) on the supply voltage input.	
	The following requirements are alternatively complied with:	
	Alternative 1	The power supply complies with the requirements for a limited power source (LPS) as per EN 60950-1.
	Alternative 2	Relevant for North America: The power supply complies with the requirements according to NEC Class 2.
	Alternative 3	<p>All of the following requirements are complied with:</p> <ul style="list-style-type: none"> ▶ The power supply complies with the requirements for a safety extra-low voltage (SELV) as per IEC/EN 60950-1. ▶ A fuse suitable for DC voltage is located in the plus conductor of the power supply. The minus conductor is on ground potential. Otherwise, a fuse is also located in the minus conductor. <p>Regarding the properties of this fuse: See “General technical data” on page 63.</p>
Only for device variants featuring supply voltage with characteristic value K (60 V DC ... 250 V DC / 110 V AC ... 230 V AC, 50 Hz ... 60 Hz):	All of the following requirements are complied with:	
	▶	<p>Supply with DC voltage: A back-up fuse suitable for DC voltage is located in the plus conductor of the power supply. The minus conductor is on ground potential. Otherwise, a back-up fuse is also located in the minus conductor. Regarding the properties of this back-up fuse: See “General technical data” on page 63.</p> <p>The wire diameter of the power supply cable is at least 1 mm² (North America: AWG16) on the supply voltage input.</p> <p>▶ Supply with AC voltage: A fuse is located in the outer conductor of the power supply. The neutral conductor is on ground potential at both voltage inputs. Otherwise, a fuse is also located in the neutral conductor. Regarding the properties of this fuse: See “General technical data” on page 63.</p> <p>The wire diameter of the power supply cable is at least 0.75 mm² (North America: AWG18) on the supply voltage input.</p>

Table 2: Requirements for connecting the supply voltage

■ **ATEX directive 2014/34/EU – specific regulations for safe operation**

In Ex zone 2, only devices with a corresponding label may be operated.

When operating the BAT-F types with characteristic value G for Approvals 1 (ATEX zone 2), the following applies:

- Never use the supply voltage with characteristic value K (60 V DC ... 250 V DC / 110 V AC ... 230 V AC, 50 Hz ... 60 Hz) in Ex zone 2.



II 3 G Ex nA IIC T4 Gc DEKRA 13ATEX0153 X

-40 °F ... +158 °F (-40 °C ... +70 °C) for temperature range characteristic value T and E

+32 °F ... +140 °F (0 °C ... +60 °C) for temperature range

characteristic value S

Temperature code T4	Ambient temperature -40 °F ... +158 °F (-40 °C ... +70 °C ; temperature range with characteristic value T and E)
	Ambient temperature +32 °F ... +140 °F (0 °C ... +60 °C ; temperature range with characteristic value S)
List of standards	EN 60079-0:2012 + A11 EN 60079-15:2010

DO NOT OPEN THE DEVICE WHEN IT IS ELECTRICALLY CHARGED. THE USB CONNECTOR MUST NOT BE USED WHEN THE DEVICE IS OPERATED IN EXPLOSIVE HAZARDOUS LOCATIONS.

Special conditions for safe use

- For supply voltage with characteristic value C (24 V DC ... 48 V DC) and W (24 V DC):
Provisions shall be made to prevent the rated voltage from being exceeded by transient disturbances of more than 119 V.
- When the temperature under rated conditions exceeds 158 °F (70 °C) at the cable or conduit entry point, or 176 °F (80 °C) at the branching point of the conductors, take care that the temperature specification of the selected cable is in compliance with the actual measured temperature values.
- Install the modules in a suitable enclosure in accordance with EN 60079-15 providing a degree of protection of at least IP54 according to EN 60529, taking into account the environmental conditions under which the equipment will be used.

■ **Relevant for use in explosion hazard areas (Hazardous Locations, Class I, Division 2):**

In Ex zone 2, only the devices with a corresponding label may be operated in explosion hazard areas Class I, Division 2.

When operating the BAT-F types in explosion hazard areas Class I, Division 2, the following applies:

Class I, Div. 2 Groups A, B, C and D



Temperature code T4	Ambient: -40 °F ... +158 °F (-40 °C ... +70 °C; for characteristic value T and E for temperature range) Ambient: +32 °F ... +140 °F (0 °C ... +60 °C; for characteristic value S for temperature range)
List of standards	FM3600, FM3611

DO NOT OPEN THE DEVICE WHEN IT IS ELECTRICALLY CHARGED.

Use this device only with the impact protection.

WARNING

EXPLOSION HAZARD

Do not disconnect or open equipment unless power has been switched off or the area is known to be **non**-hazardous.

Failure to follow this instruction can result in death, serious injury, or equipment damage.

AVERTISSEMENT

RISQUE D'EXPLOSION

Ne pas debrancher ou ouvrir tant que le circuit est sous tension, a moins qu'il ne s'agisse d'un emplacement **non** dangereux.

Le non-respect de ces instructions peut entraîner des blessures graves, voire mortelles ainsi que des dégâts matériels.



**Ordinary Location,
Non-Hazardous Area,
Non-Explosive Atmosphere**



**Class 1, Division 2
Groups A, B, C, D
Hazardous Location**

or



**Zone 2
Explosive Atmosphere**

BAT-F WLAN-Access-
Point/-Client

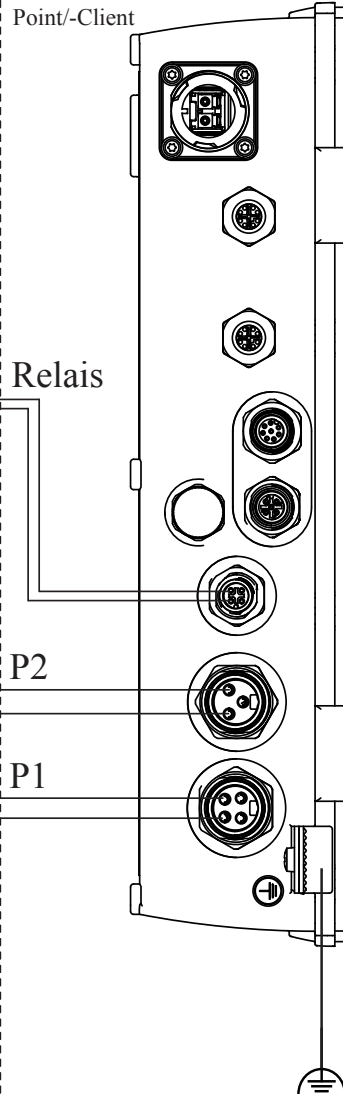

The earth conductor must be at least the same wire size (mm² oder AWG) as the supply conductors.

Relay contacts. Equipment with non-incendive field wiring parameters. Polarity is not relevant. THE RELAY TERMINALS ARE DEPENDENT UPON THE FOLLOWING ENTITY PARAMETERS:

V_{max} or U_i	I_{max} or I_i	C_i	L_i
30 V	90 mA	2 nF	1 μ H

Supply voltage with characteristic value W:
16.8 V DC – 32 V DC;

Supply voltage with characteristic value C:
18 V DC – 60 V DC;

Supply voltage with characteristic value K:
88 V AC – 265 V AC or
48 V DC – 320 V DC

Temperature Code: T4

Ambient Temperature rating:

Ta: 0 °C to +60 °C for temperature range with characteristic value “S”

Ta: –40 °C to +70 °C for temperature range with characteristic value “T” or “E”

(The characteristic value is part of the type designation on the device.)

CONTROL DRAWING for BAT-F devices according to Class 1, Division 2 Hazardous Locations or according to the European Directive 2014/34/EU



Rev.: 0

Document No.: 000183360DNR

page 1 of 2

For Use in Hazardous Locations Class I, Division 2 Groups A, B, C, D:
Only allowed for BAT-F model No's. which are individually labelled
“FOR USE IN HAZARDOUS LOCATIONS”

Non-incendive field wiring circuits must be wired in accordance with the National Electrical Code (NEC), NFPA 70 , article 501.

WARNING – EXPLOSION HAZARD – SUBSTITUTION OF ANY COMPONENTS MAY IMPAIR SUITABILITY FOR HAZARDOUS LOCATIONS OR EXPLOSIVE ATMOSPHERES.

WARNING – EXPLOSION HAZARD – DO NOT DISCONNECT EQUIPMENT UNLESS POWER HAS BEEN SWITCHED OFF OR THE AREA IS KNOWN TO BE NON-HAZARDOUS.

Notes:

The non-incendive field wiring circuit concept allows interconnection of non-incendive field wiring apparatus and associated nonincendive field wiring apparatus using any of the wiring methods permitted for unclassified locations when certain parametric conditions are met.

Capacity: $C_a \text{ or } C_0 \geq C_i + C_{\text{Cable}} ;$

Inductivity: $L_a \text{ or } L_0 \geq L_i + L_{\text{Cable}}$

CONTROL DRAWING for BAT-F devices according to Class 1, Division 2 Hazardous Locations or according to the European Directive 2014/34/EU



Rev.: 0

Document No.: 000183360DNR

page 2 of 2

■ **E marking**

The labeled devices comply with the regulations contained in the following European directive(s):

Regulation No. 10 of the Economic Commission for Europe of the United Nations (UN/ECE): **Devices with an approval are labeled with the E type approval mark.**

The optical transceivers M-SFP-SX/LC-EEC and M-SFP-LX/LC-EEC can be used (relevant for devices with approval characteristic value M). Devices featuring supply voltage with characteristic value C are not specified for operation during the motor start phase.

■ **CE marking**

The labeled devices comply with the regulations contained in the following European directive(s):

2011/65/EU and 2015/863/EU (RoHS)

Directive of the European Parliament and of the Council on the restriction of the use of certain hazardous substances in electrical and electronic equipment.

2014/53/EU (RED)

Directive of the European Parliament and of the council on the harmonization of the laws of the Member States relating to the making available on the market of radio equipment.

 This product may be operated in all EU (European Union) countries under the condition that it has been configured correctly.

In accordance with the above-named EU directive(s), the EU conformity declaration will be available to the relevant authorities at the following address:

Hirschmann Automation and Control GmbH
Stuttgarter Str. 45-51
72654 Neckartenzlingen
Germany

The product can be used in residential areas (residential, commercial and light-industrial environments) and in industrial areas.

Notes for countries with the following country codes:

								
AT	BE	BG	CH	CY	CZ	DE	DK	EE
EL	ES	FI	FR	HR	HU	IE	IT	LI
LT	LU	LV	MT	NL	NO	PL	PT	RO
RS	SE	SI	SK	TR	UK			

- ▶ The RED compliance requires compliant operation of the device in the 5 GHz band channels. Compliant operation of the device is achieved by an unchangeable determination of the country setting. To obtain RED compliance, perform the work steps described in chapter [“Obtain compliance for operation in the European Union” on page 54](#).
- ▶ Applies to the operation of devices in the 5.6 to 5.65 GHz band:
Install an antenna with an antenna gain of at least 3 dBi.
- ▶ Applies to the operation of devices with antennas having a gain of more than 8 dBi:
At temperatures lower than $-13\text{ }^{\circ}\text{F}$ ($-25\text{ }^{\circ}\text{C}$) a power reduction of 4 dB using a software setting has to be applied. This reduction applies in addition to the antenna gain setting.
- ▶ Applies to the operation of antennas having a gain of more than 18 dBi:
For the operation of 5 GHz indoor channels (channels 36 to 64) a power reduction of 4 dB using a software setting has to be applied. This reduction applies in addition to the antenna gain setting.
- ▶ Applies to the operation of the BAT-ANT-N-14G-IP23 antenna:
In addition to the antenna cable supplied, the use of the BAT-CLB-2 N m-f antenna is required.
[See “Accessories” on page 82](#).

Notes for Germany (DE), Ireland (IE), and the United Kingdom (UK):

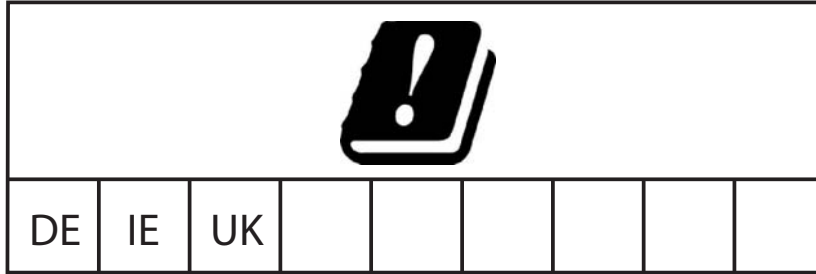

Operation in the 5.8 GHz band at a radiated power (EIRP) >25 mW is subject to meeting the following conditions:

- ▶ Germany (DE)
Frequency range: 5725 MHz to 5875 MHz
Condition: The usage of this band is restricted to commercial public telecommunication services. Registration at the Federal Network Agency is required.
Name and website of the competent authority:
Bundesnetzagentur
www.bundesnetzagentur.de

- ▶ Ireland (IE)
Frequency range: 5725 MHz to 5875 MHz
Condition: Registration of operational base stations
Name and website of the competent authority:
Commission for Communications Regulation
www.comreg.ie

- ▶ United Kingdom (UK):
Frequency range: 5725 MHz to 5850 MHz
Condition: Light-licensing regime
Name and website of the competent authority:
Ofcom
www.ofcom.org.uk

■ LED or laser components

LED or LASER components according to IEC 60825-1 (2014):
CLASS 1 LASER PRODUCT
CLASS 1 LED PRODUCT

■ **FCC note**

Supplier's Declaration of Conformity 47 CFR § 2.1077 Compliance Information

BAT-F

U.S. Contact Information

Belden – St. Louis
1 N. Brentwood Blvd. 15th Floor
St. Louis, Missouri 63105, United States
Phone: 314.854.8000

This device complies with part 15 of the FCC rules.

Operation is subject to the following two conditions:

- ▶ This device may not cause harmful interference, and
- ▶ This device must accept any interference received, including interference that may cause undesired operation.

This equipment has been tested and found to comply with the limits for a Class B digital device, pursuant to part 15 of the FCC Rules. These limits are designed to provide reasonable protection against harmful interference in a residential installation. This equipment generates, uses and can radiate radio frequency energy and, if not installed and used in accordance with the instructions, may cause harmful interference to radio communications. However, there is no guarantee that interference will not occur in a particular installation. If this equipment does cause harmful interference to radio or television reception, which can be determined by turning the equipment off and on, the user is encouraged to try to correct the interference by one or more of the following measures:

- Reposition the receiver antenna or change the angle of the receiver antenna.
 - Increase the separation between the device and the receiver.
 - Connect the device to a different outlet on a different power supply cable from that to which the receiver is connected.
 - Consult a specialist retailer or an electronic systems engineer for help.
- Changes or modifications not expressly approved by the holder of the certificate could void the user's authority to operate this equipment.

EWLAN1 Module

Note for the use in the USA and in Canada

The following section applies to BAT-F variants with the characteristic value US (USA/Canada) for country approvals which are labeled as follows:

Contains Transmitter Module

FCC ID: U99EWLAN1
IC: 4019A-EWLAN1

This equipment complies with FCC and IC RSS-102 radiation exposure limits set forth for an uncontrolled environment. Install and operate this equipment with a minimum distance of 19.7 in (50 cm) (related to a 9 dBi antenna) between the radiation source and your body.

The antenna used for this transmitter must not be co-located with any other transmitters within a host device, except in accordance with FCC multi-transmitter product procedures.

This transmitter is restricted to indoor use only within the 5.15 to 5.25 GHz band to reduce potential for harmful interference to co-channel mobile satellite systems.

The power of the device was reduced by 6 dB on channel 149 (5745 MHz) for all modulations to be compliant to the band edge limits.

This Class B digital apparatus complies with Canadian ICES-003. Cet appareil numérique de la classe B est conforme à la norme NMB-003 du Canada.

To reduce potential radio interference to other users, the antenna type and its gain should be so chosen that the equivalent isotropically radiated power (EIRP) is not more than that permitted for successful communication.

This device has been designed to operate with the antennas listed below in point-to-multipoint systems, and having a maximum gain of 9 dBi:

Antenna(s) for operation with this device:	Permitted band of operation		
	2.4 GHz band	5.18 GHz ... 5.24 GHz band	5.745 GHz ... 5.825 GHz band
BAT-ANT-RSMA-2AGN-R ^a	Yes	Yes	Yes
BAT-ANT-N-3AGN-IP67	Yes	Yes	Yes
BAT-ANT-N-MiMoDB-5N-IP65	Yes	Yes	Yes
BAT-ANT-N-MiMo5-9N-IP65	No	Yes	Yes
BAT-ANT-N-8G-DS-IP65	Yes	No	No

- a. Note: When using 3 antennas type BAT-ANT-RSMA-2AGN-R, you must align each antenna in another spatial direction (x-y-z) so that one antenna is arranged vertically to the device and the other two antennas are arranged at right angles to each other.

The FCC approval is valid only in conjunction with the listed antennas. If other antennas are used, the approval expires. The responsibility lies with the operator of the system. The required antenna impedance is 50 Ω.

Applies exclusively to device variants with approval for the 4.9 GHz band (Approvals 2, characteristic value P) according to FCC 47CFR Part 90 Subpart Y:

- ▶ Operation of the device in the 4.9 GHz band requires trained personnel familiar with the regulatory requirements for operation according to FCC 47CFR Part 90 Subpart Y.
- ▶ The 4.9 GHz band is a licensed band. State and local government entities that provide public safety services are eligible to apply for 4.9 GHz licenses. For more information, see the Federal Communications Commission (FCC) regulations. The installer or operator is responsible for obtaining the appropriate site licenses before installing or using the system.
- ▶ The antenna gain of the antenna must not exceed 9 dBi.
- ▶ For antennas with an antenna gain >9 dBi, the transmit power must be reduced accordingly in the device software. You can find step-by-step instructions for reducing the transmit power in the device software in the [“Configuring the transmit power for the 4.9 GHz band” on page 59](#) chapter.

E WLAN2 Module

Note for the use in the USA and in Canada

The following section applies to BAT-F variants with the characteristic value US (USA/Canada) for country approvals which are labeled as follows:

Contains Transmitter Module

FCC ID: U99EWLAN2

IC: 4019A-EWLAN2

This equipment complies with FCC and IC RSS-102 radiation exposure limits set forth for an uncontrolled environment. This equipment should be installed and operated with minimum distance of 19.7 in (50 cm) (related to a 18 dBi antenna) between the radiation source and your body.

The antenna used for this transmitter must not be co-located with any other transmitters within a host device, except in accordance with FCC multi-transmitter product procedures.

This transmitter is restricted to indoor use only within the 5.15 to 5.25 GHz band to reduce potential for harmful interference to co-channel mobile satellite systems.

This Class B digital apparatus complies with Canadian ICES-003. Cet appareil numérique de la classe B est conforme à la norme NMB-003 du Canada.

To reduce potential radio interference to other users, the antenna type and its gain should be so chosen that the equivalent isotropically radiated power (EIRP) is not more than that permitted for successful communication.

This device has been designed to operate with the antennas listed below having a maximum gain of 18 dBi:

Antenna(s) for operation with this device:	Permitted band of operation		
	2.4 GHz band	5.18 GHz ... 5.24 GHz band	5.745 GHz ... 5.825 GHz band
BAT-ANT-RSMA-2AGN-R ^a	Yes	Yes	Yes
BAT-ANT-N-3AGN-IP67	Yes	Yes	Yes
BAT-ANT-N-MiMoDB-5N-IP65	Yes	Yes	Yes
BAT-ANT-N-MiMo5-9N-IP65	No	Yes	Yes
BAT-ANT-N-8G-DS-IP65	Yes	No	No
BAT-ANT-N-MiMo-18N-IP65 ^b	No	No	Yes

- a. Note: When using 3 antennas type BAT-ANT-RSMA-2AGN-R, you must align each antenna in another spatial direction (x-y-z) so that one antenna is arranged vertically to the device and the other two antennas are arranged at right angles to each other.
- b. Note: Connect the BAT-ANT-N-MiMo-18N-IP65 to the WLAN module as follows:
- Connect the antenna port "Ver" with the WLAN-antenna-port 1.
 - Connect the antenna port "+45 °" with the WLAN antenna port 2.
 - Connect the antenna port "-45 °" with the WLAN antenna port 3.
 - Connect the BAT-ANT-N-MiMo-18N-IP65 antenna in this way exclusively.
- Differing connection configurations are illegal.

The FCC approval is valid only in conjunction with the listed antennas. If other antennas are used, the approval expires. The responsibility lies with the operator of the system. The required antenna impedance is 50 Ω.

■ Note for the use in the Japan

This note applies to BAT-F variants with the characteristic value JP (Japan) for country approvals that are labeled as follows:

- ▶ "Contains MIC ID: 204-310014"
- ▶ „5GHz band: この製品は屋内においてのみ使用可能です”

Devices with the characteristic value JP for country approvals are suitable for usage with the following antennas:

Antennas for operation with this device:	Permissible frequency bands	
	2.4 GHz band	5 GHz band
BAT-ANT-N-3AGN-IP67	Yes	Yes
BAT-ANT-RSMA-2AGN-R	Yes	Yes
BAT-ANT-6ABG-IP65	Yes	Yes
BAT-ANT-N-MiMoDB-5N-IP65	Yes	Yes
BAT-ANT-N-8G-DS-IP65	Yes	No
BAT-ANT-N-9A-DS-IP65	No	Yes
BAT-ANT-N-6G-IP65	Yes	No

BAT-ANT-N-5A-IP65	No	Yes
BAT-ANT-N-MiMo-9N-IP65	No	Yes

The use of antennas missing in this list is prohibited. The 5 GHz band is restricted to indoor usage.

■ **Note for the use in Oman**

This note applies to BAT-F variants with the characteristic value OM (Oman) for country approvals:

This telecommunication equipment complies with the technical requirements of the Telecommunications Regulatory Authority (TRA) and is labeled as follows:

OMAN - TRA
R/4116/17
D100428

■ **Recycling note**

After usage, this device must be disposed of properly as electronic waste, in accordance with the current disposal regulations of your county, state, and country.



About this manual

The “Installation” user manual contains a device description, safety instructions, a description of the display, and the other information that you need to install the device.

Documentation mentioned in the “User Manual Installation” that is not supplied with your device as a printout can be found as PDF files for downloading on the Internet at: <https://www.doc.hirschmann.com>

Key

The symbols used in this manual have the following meanings:

	Listing
	Work step
	Subheading

1 Description

1.1 General description

The devices allow you to set up WLANs (Wireless Local Area Networks) in a local network. In contrast to a conventional network connection through copper cables and fiber optic cables, some of the communication is performed by means of a radio link.

The devices allow you to install a new LAN or expand an existing LAN. Thanks to their high level of flexibility, the OpenBAT device is suitable for a wide range of applications. Anywhere that high bandwidths, stable operation and network security is required, WLAN with these devices provides the ideal solution.

The devices are dual-band industrial high-performance wireless LAN access points or clients complying with IEEE 802.11a/b/g/h/n. They provide a high radio output with a bandwidth of up to 450 Mbit/s. The devices support MIMO (Multiple Input Multiple Output) and Multipath. The bandwidth is increased by using the multipath transmission by means of reflections. Each WLAN module has 3 antennas for sending and receiving, to ensure stable network coverage with few shadow areas.

You can choose from between a wide range of variants. You have the option to set up your device individually based on different criteria:

- ▶ Access point or client
- ▶ Number of WLAN modules
- ▶ Number of ports
- ▶ Supply voltage range
- ▶ Configuration (with or without equipment package)
- ▶ Software options
- ▶ Temperature range
- ▶ Approvals

The device is designed for the special requirements of industrial automation. The device meets the relevant industry standards, provides very high operational reliability, even under extreme conditions, and also long-term reliability and flexibility.

The device works without a fan.

The device complies with the degrees of protection IP65/67.

The following installation options are available:

- ▶ Mounting on a flat surface
- ▶ Mounting on a pole

You have the option of choosing various media to connect to the end devices and other network components:

- ▶ Twisted pair cable
- ▶ Multimode F/O
- ▶ Singlemode F/O

There are convenient options for managing the device. Manage your devices via:

- ▶ Web browser
- ▶ SSH
- ▶ Telnet
- ▶ HiDiscovery (software for putting the device into operation)
- ▶ Management software (for example Industrial HiVision, LANconfig/ LANmonitor)

The Network Management Software Industrial HiVision provides you with options for smooth configuration and monitoring. You find further information on the Internet at the Hirschmann product pages:

<http://www.hirschmann.com/en/QR/INET-Industrial-HiVision>

- ▶ V.24 interface (locally on the device)

The device provides you with a large range of functions, which the manuals for the operating software inform you about. You can download these manuals as PDF files from the Internet on the Hirschmann product pages (<http://www.doc.hirschmann.com>).

The Hirschmann network components help you ensure continuous communication across all levels of the company.

1.2 Device name and product code

The device name corresponds to the product code. The product code is made up of characteristics with defined positions. The characteristic values stand for specific product properties.

You have numerous options of combining the device characteristics. You can determine the possible combinations using the configurator which is available in the Belden Online Catalog <https://catalog.belden.com> on the web page of the device.

Item	Characteristic	Characteristic value	Description
1 ... 5	Devices of the OpenBAT family	BAT-F	IP65/67 housing
6 ... 7	Country approvals	XX	You can determine the current country approvals using the configurator (https://catalog.belden.com)
	Example: Singapore	Example: SG	
8	Slot 1	W	WLAN module
9	Slot 2	W	WLAN module
		9	Not assembled
10	Slot 3	9	Not assembled
11	Access point or client	A	Access Point
		C	Client
12	Supply voltage 1	C	Power supply solely through a 7/8" connector Rated voltage range DC: 24 V DC ... 48 V DC
		K	Power supply solely through a 7/8" connector Rated voltage range DC: 60 V DC ... 250 V DC Rated voltage range AC: 110 V AC ... 230 V AC, 50 Hz ... 60 Hz
		P	Power supply exclusively via PoE
		W	Power supply through a 7/8" connector Rated voltage DC: 24 V DC
13	Supply voltage 2	C	Power supply solely through a 7/8" connector Rated voltage range DC: 24 V DC ... 48 V DC
		K	Power supply solely through a 7/8" connector Rated voltage range DC: 60 V DC ... 250 V DC Rated voltage range AC: 110 V AC ... 230 V AC, 50 Hz ... 60 Hz
		W	Power supply through a 7/8" connector Rated voltage DC: 24 V DC
		9	Not present

Table 3: Device name and product code

Item	Characteristic	Characteristic value	Description
14	Approvals 1	F	Class I, Division 2 Groups A, B, C, D Hazardous Locations
		G	ATEX Zone 2
		I	Substation applications (EN 61850)
		K	Rail applications (EN 50155)
		M	Motor vehicles applications (E type-approval mark, ECE No. 10)
		9	No additional approvals
15	Approvals 2	H	WLAN module version for high-gain antennas
		M	Motor vehicles applications (E type-approval mark, ECE No. 10)
		P	Approval for the 4.9 GHz band
		9	No additional approvals
16	Mounting	A	Indoor operator access area ^a
		B	Indoor service access area ^b
17 ... 18	Ethernet port 1	O5	<p>Combo port – you can use these ports for alternative purposes:</p> <ul style="list-style-type: none"> ▶ alternatively, depending on device variant <ul style="list-style-type: none"> ▶ Supply voltage with characteristic value C (24 V DC ... 48 V DC) and K (60 V DC ... 250 V DC / 110 V AC ... 230 V AC, 50 Hz ... 60 Hz): 8-pin, “X”-coded M12 socket for 10/100/1000 Mbit/s twisted pair connections ▶ Supply voltage with characteristic value P (Power supply only through PoE) and W (24 V DC): 8-pin, “X”-coded M12 socket for 10/100/1000 Mbit/s PoE PD connections ▶ SFP slot for 1000 Mbit/s F/O connections Design: IP67-V1 connector according to IEC 61076-3-106, variant 1
19 ... 20	Ethernet port 2	T6	8-pin, “X”-coded M12 socket for 10/100/1000 Mbit/s twisted pair connections
		99	Not present

Table 3: Device name and product code

Item	Characteristic	Characteristic value	Description
21	Temperature range	E	Extended with Conformal Coating -40 °F ... +158 °F (-40 °C ... +70 °C)
		K	Extended with Conformal Coating and approvals 1, characteristic value K, railway applications: -40 °F ... +131 °F (-40 °C ... +55 °C)
		S	Standard +32 °F ... +140 °F (0 °C ... +60 °C)
		T	Extended -40 °F ... +158 °F (-40 °C ... +70 °C)
22	Software option 1	A	VPN-5
		B	VPN-50
		C	VPN-100
		9	Not present
23	Software option 2	9	Not present
24	Software option 3	A	AutoWDS
		D	Public Spot
		P	PRP
		9	Not present
25	Configuration	Z	Equipment package
		9	Hirschmann standard
26	Device model	H	Hirschmann standard

Table 3: *Device name and product code*

- a. Location for which one of the following conditions apply when one operates it correctly:
 - The area is accessible without tools.
 - The person responsible for the area has provided access for the operator intentionally.
 - The operator knows of the access possibilities, regardless of whether they need a tool.
- b. Location outside the operator area to which the service personnel has access, even when the device is switched on.

1.3 Device view

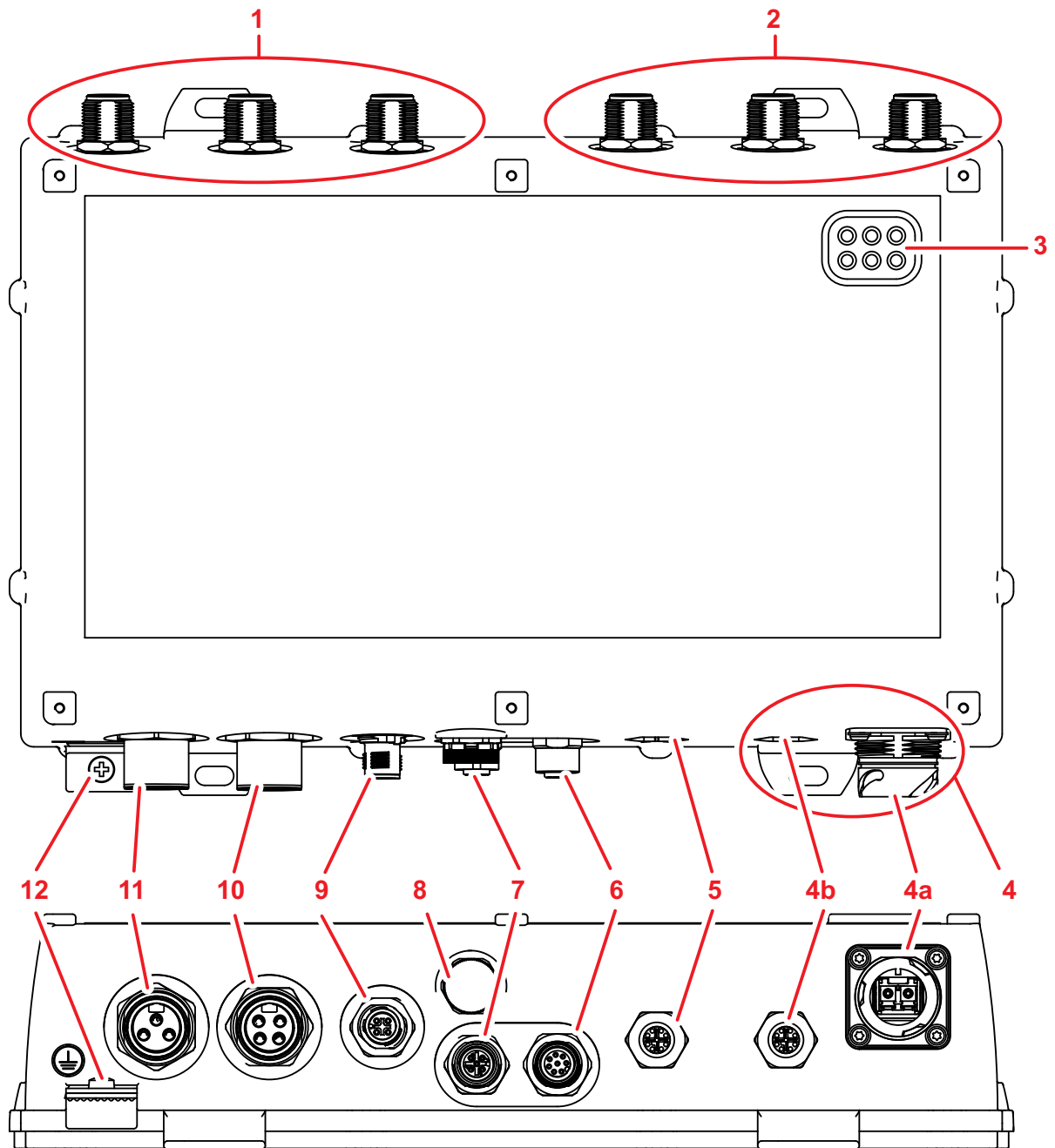

Front view (using the example BAT-FEUWW9ACK99DO5T1SA99)

1	alternatively, depending on device variant	For device variants with 2 WLAN modules: 3 × N socket for WLAN module 1
		For device variants with 1 WLAN module: Not present
2	alternatively, depending on device variant	For device variants with 2 WLAN modules: 3 × N socket for WLAN module 2
		For device variants with 1 WLAN module: 3 × N socket for WLAN module 1
3	LED display elements	

4	Ethernet port 1 Combo port – you can use these ports for alternative purposes:	
4a	SFP slot for 1000 Mbit/s F/O connections Design: IP67-V1 connector according to IEC 61076-3-106, variant 1	
4b	alternatively, depending on device variant	Supply voltage with characteristic value C (24 V DC ... 48 V DC) and K (60 V DC ... 250 V DC / 110 V AC ... 230 V AC, 50 Hz ... 60 Hz): 8-pin, "X"-coded M12 socket for 10/100/1000 Mbit/s twisted pair connections Supply voltage with characteristic value P (Power supply only through PoE) and W (24 V DC): 8-pin, "X"-coded M12 socket for 10/100/1000 Mbit/s PoE PD connections
5	Optional: Ethernet port 2	8-pin, "X"-coded M12 socket for 10/100/1000 Mbit/s twisted pair connections
6	8-pin, "A"-coded M12 socket for V.24 interface	
7	5-pin, "A"-coded M12 socket for USB interface	
8	alternatively, depending on device variant	Approvals 1 with characteristic value F and G: The reset button below a screwable IP67 pressure compensating cap Approvals 1 with characteristic value I, K, M and 9: Reset button behind a screwable IP65/67 protection cap
9	Only for device variants featuring supply voltage with characteristic value C (24 V DC ... 48 V DC), K (60 V DC ... 250 V DC / 110 V AC ... 230 V AC, 50 Hz ... 60 Hz) or W (24 V DC): 4-pin, "A"-coded M12 plug for signal contact	
10	Supply voltage connection 1 alternatively, depending on device variant	Supply voltage with characteristic value C (24 V DC ... 48 V DC) 4-pin, 7/8" connector Supply voltage with characteristic value K (60 V DC ... 250 V DC / 110 V AC ... 230 V AC, 50 Hz ... 60 Hz) 3-pin, 7/8" connector Supply voltage with characteristic value P (Power supply only through PoE): Not present Supply voltage with characteristic value W (24 V DC): 4-pin, 7/8" connector
11	Supply voltage connection 2 alternatively, depending on device variant	Supply voltage with characteristic value C (24 V DC ... 48 V DC) 4-pin, 7/8" connector Supply voltage with characteristic value K (60 V DC ... 250 V DC / 110 V AC ... 230 V AC, 50 Hz ... 60 Hz) 3-pin, 7/8" connector Supply voltage with characteristic value P (Power supply only through PoE): Not present Supply voltage with characteristic value W (24 V DC): 4-pin, 7/8" connector
12	Connection for protective ground	

1.4 Power supply

Only for device variants featuring supply voltage with characteristic value C (24 V DC ... 48 V DC), K (60 V DC ... 250 V DC / 110 V AC ... 230 V AC, 50 Hz ... 60 Hz) or W (24 V DC):

For redundant and failure-resistant power supply, you have the option of connecting multiple voltage sources in any combination at the same time. The device selects the used voltage source automatically.

Switching to a redundant voltage source possibly occurs with a short delay. If the active power source is lost and another power source takes over the power supply to the device, the device reboots if necessary to activate the redundant power supply.

1.4.1 Supply voltage with the characteristic value C (24 V DC ... 48 V DC)

A 4-pin 7/8" plug is available for the power supply to the device.

Further information:

[“Supply voltage with the characteristic value C \(24 V DC ... 48 V DC\)” on page 47](#)

1.4.2 Supply voltage with the characteristic value K (60 V DC ... 250 V DC / 110 V AC ... 230 V AC, 50 Hz ... 60 Hz)

A 3-pin 7/8" plug is available for the power supply to the device.

Further information:

[“Supply voltage with the characteristic value K \(60 V DC ... 250 V DC / 110 V AC ... 230 V AC, 50 Hz ... 60 Hz\)” on page 47](#)

1.4.3 Supply voltage with the characteristic value P (Power supply only through PoE)

Note: With supply voltage with the characteristic value P (Power supply only through PoE), the signal contact is omitted.

Your device is a PD (powered device). PSE (power sourcing equipment) connected via a twisted pair cable on the PoE PD port serves as the PoE power supply voltage. The PoE power supply means that no separate power supply is required for your device.

Further information:

[“10/100/1000 Mbit/s PoE PD port” on page 50](#)

1.4.4 Supply voltage with the characteristic value W (24 V DC)

You have the following options to supply your device with voltage:

■ Power supply through a 7/8" connector

A 4-pin 7/8" plug is available for the power supply to the device.

Further information:

[“Supply voltage with the characteristic value K \(60 V DC ... 250 V DC / 110 V AC ... 230 V AC, 50 Hz ... 60 Hz\)” on page 33](#)

■ Power supply through PoE

Your device is a PD (powered device). PSE (power sourcing equipment) connected via a twisted pair cable on the PoE PD port serves as the PoE power supply voltage. The PoE power supply means that no separate power supply is required for your device.

Further information:

[“10/100/1000 Mbit/s PoE PD port” on page 34](#)

1.5 Ethernet ports

You can connect end devices and other segments to the device ports using twisted pair cables or optical fibers (F/O).

You find information on pin assignments for making patch cables here:

[“Pin assignments” on page 35](#)

1.5.1 Gigabit combo port

You have the option of alternatively connecting a twisted pair cable via a RJ45 socket or an optical fiber via a SFP transceiver to a combo port.

Only plug a connector or SFP transceiver that you want to use for the data transmission into the socket of the combo port.

■ 10/100/1000 Mbit/s PoE PD port

Only device variants featuring supply voltage with characteristic value P (Power supply only through PoE) or W (24 V DC) have this port.

The 10/100/1000 Mbit/s PoE PD port offers you the ability to connect network components according to the IEEE 802.3 10BASE-T/100BASE-TX/1000BASE-T and IEEE 802.3af/at standard.

This port supports:

- ▶ Autocrossing
- ▶ Autonegotiation
- ▶ Autopolarity
- ▶ 10 Mbit/s half-duplex mode, 10 Mbit/s full duplex mode

- ▶ 100 Mbit/s half-duplex mode, 100 Mbit/s full duplex mode
- ▶ 1000 Mbit/s full duplex

The socket housing is electrically connected with the device housing.

■ **10/100/1000 Mbit/s twisted pair port**

Only device variants featuring supply voltage with characteristic value C (24 V DC ... 48 V DC) or K (60 V DC ... 250 V DC / 110 V AC ... 230 V AC, 50 Hz ... 60 Hz) have this port.

The 10/100/1000 Mbit/s twisted pair port allows you to connect network components according to the IEEE 802.3 10BASE-T/100BASE-TX/1000BASE-T standard.

This port supports:

- ▶ Autocrossing
- ▶ Autonegotiation
- ▶ Autopolarity
- ▶ 10 Mbit/s half-duplex mode, 10 Mbit/s full duplex mode
- ▶ 100 Mbit/s half-duplex mode, 100 Mbit/s full duplex mode
- ▶ 1000 Mbit/s full duplex

The socket housing is electrically connected with the device housing.

■ **1000 Mbit/s F/O port**

This port is designed as an IP67-V1 connector according to IEC 61076-3-106, variant 1.

The 1000 Mbit/s F/O port offers you the ability to connect network components according to the IEEE 802.3 1000BASE-SX/1000BASE-LX standard.

This port supports:

- ▶ Full duplex mode

1.5.2 10/100/1000 Mbit/s twisted-pair connection (optional)

See the properties of this port [“10/100/1000 Mbit/s twisted pair port” on page 35](#).

1.5.3 Pin assignments

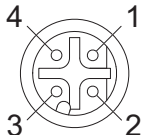
M12 4-pin (“D”-coded)	Pin	Data	PoE
	1	TX+	Positive V_{PSE}
	2	RX+	Negative V_{PSE}
	3	TX-	Positive V_{PSE}
	4	RX-	Negative V_{PSE}

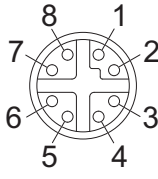
M12 8-pin ("X"-coded)	Pin	10/100 Mbit/s	1000 Mbit/s	PoE
	1	RX+	BI_DB+	Negative V_{PSE}
	2	RX-	BI_DB-	Negative V_{PSE}
	3	TX+	BI_DA+	Positive V_{PSE}
	4	TX-	BI_DA-	Positive V_{PSE}
	5	—	BI_DC+	—
	6	—	BI_DC-	—
	7	—	BI_DD-	—
	8	—	BI_DD+	—

1.6 Connections for antennas

The devices have 3 N sockets on each WLAN module.

The "Antenna Guide" document provides an overview of the antennas that can be used as well as the suitable antenna accessories.

The manual is available for download on the Internet: <https://www.doc.hirschmann.com>

1.7 Display elements

After the supply voltage is set up, the Software starts and initializes the device. Afterwards, the device performs a self-test. During this process, various LEDs light up.

These actions take less than 1 minute.

LED display elements for device status and port status

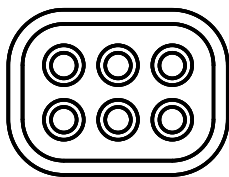

P1 WLAN1 ETH1

P2 WLAN2 ETH2

LED display elements for device status:	P1	Supply voltage connection 1
	P2	Supply voltage connection 2
	WLAN1	WLAN module 1
	WLAN2	For device variants with 2 WLAN modules: WLAN module 2
Note: For device variants with 1 WLAN module, this LED is unlabeled and solely lights up after the configuration is reset (hard reset).		
LED display elements for port status:	ETH1	Ethernet port 1
	ETH2	Optional: Ethernet port 2
Note: For device variants without this port, this LED is unlabeled.		

1.7.1 Meaning of the LEDs

The following terms describe the behavior of the LEDs:

- ▶ **Regular flashing:** the LED switches on and off at regular intervals in the specified sequence (e.g. red/off).
- ▶ **Brief flashing:** the LED lights up very briefly, then remains inactive for a much longer time (about 10 × as long).

- ▶ **Inverse flashing:** the LED remains inactive for a very short time (about 10 × as long), then lights up for a much longer time (about 10 × as long).
- ▶ **Flickering:** the LED switches on and off at irregular intervals.
- ▶ **Running light:** coordinated glowing of several LEDs which gives the optical impression that a light source is moving from left to right and back.

1.7.2 Device state

These LEDs provide information about conditions which affect the operation of the whole device.

P1, P2 (green/red LED)		Meaning
off		Connection is voltage-free. ^a
green	glowing	Voltage present, device is operational.
red/green	flashing (slowly)	Charge lock active. ^b
red/green	flashing (quickly)	Unprotected configuration as no password or the default password is set. ^a
red/off	flashing (quickly)	Hardware error detected. ^b
red/green	Running light of P1 and P2	A BAT controller WLC with an incompatible protocol is connected.
green	Running light of P1 and P2	Device is searching for a BAT controller WLC.

- a. If both connections are voltage-free, the power supply is possibly running via an active Ethernet connection at the PoE port. The port status LEDs directly on the port show you whether an Ethernet connection is active.
- b. Which LED displays the corresponding response depends on the configuration of the power supply connections. P2 always performs signaling if a voltage is solely present on the connection for supply voltage 2. In all other cases, signaling is performed by P1.

WLAN 1, WLAN 2 (green/red LEDs)		WLAN mode	Meaning
off		all	No WLAN network defined or WLAN module deactivated. WLAN module does not send any beacons.
green	glowing	Access Point, P2P	At least one WLAN network defined and WLAN module activated. WLAN module sends beacons.
green	flashing inversely	Access Point, P2P	Number of flashes = Number of connected WLAN stations and P2P radio lines, then there is a break.
green	flashing	Access Point, P2P	DFS scanning or another scan procedure.
green	flashing	Client, P2P	Signal strength: The faster the LED blinks, the better the signal and thus the connection quality.
red	flashing	all	Hardware error detected in the WLAN module.

1.7.3 Port status

These LEDs provide port-related information.

ETH1, ETH2 (green/yellow LED)	Meaning
off	No network device connected

ETH1, ETH2 (green/yellow LED)		Meaning
green	glowing	Ethernet connection active
yellow	flickering	Data traffic

1.8 Management interfaces

1.8.1 V.24 interface (external management)

This interface is designed as an 8-pin, “A”-coded M12 plug. The V.24 user interface is serial and allows you to connect the following devices directly:

- ▶ External management station (VT100 terminal or PC with appropriate terminal emulation). With this management station, the Command Line Interface (CLI) is available to you. Furthermore, the system monitor is available to you at the system start.
You will find more information here:
 - [table 5 on page 40](#)
- ▶ BAT-F device. Connecting the BAT-F device allows you to automate the configuration of a point-to-point WLAN line by connecting two devices directly via the serial interface.
You will find more information here:
 - User Manual Configuration Guide
The manual is available for download on the Internet: <https://www.doc.hirschmann.com>
 - [table 6 on page 40](#)

VT100 terminal settings	
Speed	115200 bit/s
Data	8 bit
Stopbit	1 bit
Handshake	Hardware
Parity	none

The socket housing is electrically connected to the device casing. The V.24 interface is electrically insulated from the supply voltage.

- Only use a shielded cable.

Pins of the M12 socket on the device	Pin	Function	Description of functions
	1	GND	Ground
	2	DTR	Data terminal ready
	3	TxD	Transmit data
	4	RxD	Receive data
	5	DCD	Data carrier detect
	6	DSR	Dataset ready
	7	RTS	Request to send
	8	CTS	Clear to send

Table 4: Pin assignment of the V.24 interface, 8-pin, "A"-coded M12 socket

Pins of the M12 socket on the device	Pin assignment for the connection with a cable	Pins of the DB9 plug on the external device
	1 ————— 5	
	2 ————— 4	
	3 ————— 3	
	4 ————— 2	
	5 ————— 1	
	6 ————— 6	
	7 ————— 7	
	8 ————— 8	

Table 5: Pin assignment for the connection with a cable: 8-pin, „A“-coded M12 plug to DB9 connector

You can order a terminal cable M12, 8-pin, to DB9 as an accessory. See [“Accessories” on page 82](#).

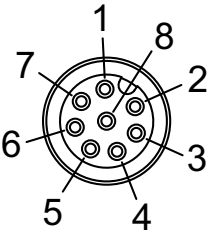
Pins of the M12 socket on the device	Pin assignment for the connection with a cable	Pins of the M12 socket on the device
		

Table 6: Pin assignment for the connection with a cable: 8-pin, "A"-coded M12 plug to 8-pin, "A"-coded M12 plug (point-to-point WLAN line)

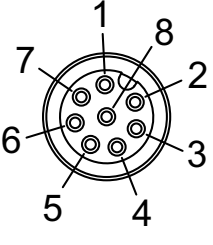
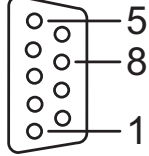
Note: With the point-to-point WLAN line, the following pins are short-circuited at both ends:

- ▶ 2 (DTR) + 6 (DSR)
- ▶ 7 (RTS) + 8 (DSR)

1.8.2 USB interface

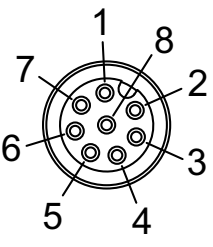
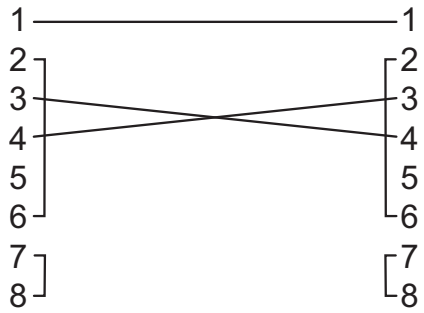
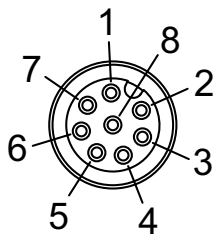
This interface offers you the ability to connect the storage medium AutoConfiguration Adapter ACA21-M12 (EEC) / ACA22-M12 (EEC). This storage medium is used for saving/loading the configuration and diagnostic functions, and for loading the software.

This interface is a 5-pin, “A”-coded M12 socket with shielding.

Note: The AutoConfiguration adapter **ACA11-M12** available for certain Hirschmann devices is incompatible with BAT-F devices.

	Pin	Function
	1	U _{in} 5 V
	2	N.C. Not used
	3	D- Data -
	4	GND Ground (0 V)
	5	D+ Data +

Table 7: Pin assignment of the USB interface, 5-pin, “A”-coded M12 socket

1.9 Signal contact

Only device variants featuring supply voltage with characteristic value C (24 V DC ... 48 V DC), K (60 V DC ... 250 V DC / 110 V AC ... 230 V AC, 50 Hz ... 60 Hz) or W (24 V DC) have a signal contact.

You have the option of setting the signal contact manually using the device management.

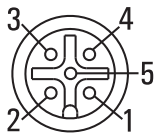
Further information:

[“Signal contact” on page 49](#)

1.10 Reset button

The device has a reset button.

Note: The reset button is located behind a screwable IP65/67 pressure-equalization element (Approvals 1 with characteristic value F and G), or a IP65/67 protection cap (Approvals 1 with characteristic value I, K, M and 9). The tightening torque is 4.42 lb-in to 8.85 lb-in (0.5 Nm to 1.0 Nm).

You will find more information in the “User Manual Configuration Guide”, in the chapter “Using the Boot Configurations”.

The manual is available for download on the Internet: <https://www.doc.hirschmann.com>

2 Installation

The devices have been developed for practical application in a harsh industrial environment.

On delivery, the device is ready for operation.

To protect the exposed uninstalled contacts of the components from dirt, connect the individual system components in a dry and clean working area. The device fulfills the protection class IP65/67 under the following conditions, exclusively:

- ▶ All the connectors and cables connected also fulfill protection class IP65/67.
- ▶ The protection screws seal all unused connections and ports. The protection screws also fulfill the protection class IP65/67.

If your device is equipped with an impact protection, proceed as follows when mounting the components:

- Remove the impact protection.
- Mount the components.
- Mount the impact protection.

Perform the following steps to install the device:

- ▶ [Checking the package contents](#)
- ▶ [Installing and grounding the device](#)
- ▶ [Installing an SFP transceiver \(optional\)](#)
- ▶ [Installing the antennas](#)
- ▶ [Connecting the power supply and the signal contact lines](#)
- ▶ [Operating the device](#)
- ▶ [Connecting data cables](#)

2.1 Checking the package contents

- Check whether the package includes all items named in the section [“Scope of delivery” on page 81](#).
- Check the individual parts for transport damage.

2.2 Installing and grounding the device

2.2.1 Installing the device onto or on a flat surface

You have the option of attaching the device with suitable hardware to a vertical flat surface.

Requirements for the fastening components:

- ▶ The diameter of the mounting hardware is maximum 0.20 in (5 mm).
- ▶ The head diameter is maximum 0.47 in (12 mm).
- ▶ The diameter of a flat washer used is maximum 0.48 in (12 mm).
- Prepare the assembly at the installation site.
[See “Dimension drawings” on page 65.](#)
- Install the device with suitable fastening components.
- Seal all unused connections and ports with protection screws.
[See “Accessories” on page 82.](#)

2.2.2 Installing the device on a pole

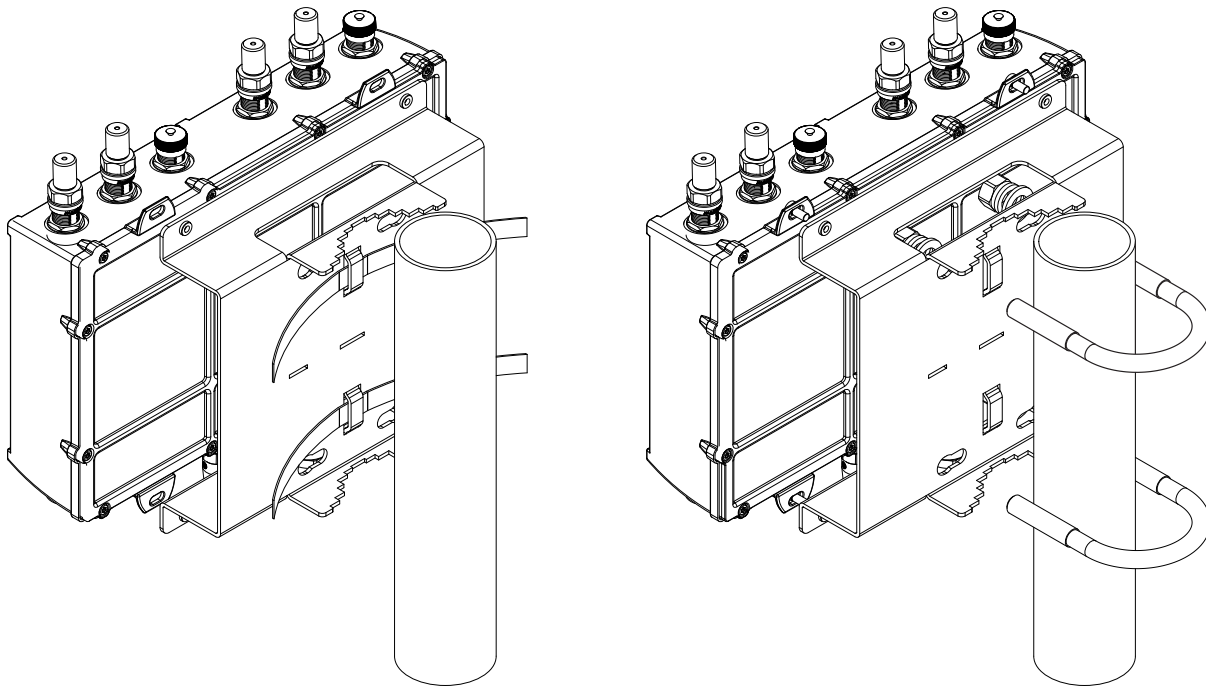

You have the option of installing the device on a pole, pipe, strut, or on a similarly stable construction using a pole mounting set.

The pole mounting set you obtain as an accessory.

[See “Accessories” on page 82.](#)

- ▶ The clamping diameter of the mast clamp is maximum 2.56 in (65 mm).
- ▶ Tightening straps, available from a specialist dealer, enable you to clamp a larger mast diameter.
 - ▶ maximum width of the tightening strap: 0.63 in (16 mm)
 - ▶ maximum thickness of the tightening strap: 0.05 in (1.3 mm)

2.2.3 Grounding the device

The device is grounded via the separate ground screw.

- Terminate the ground conductor between the fastening plates.
- Make sure the fastening plates cover the stripped part of the ground conductor completely.
- Tightening the ground screw.

2.3 Installing an SFP transceiver (optional)

Use only Hirschmann SFP transceivers which are suitable for usage with the device.

See “Accessories” on page 82.

The SFP mounting tool available as an accessory makes it easier for you to insert the SFP transceivers.

See “Removing an SFP transceiver (optional)” on page 62.

- Remove the protection cap from the SFP transceiver.
- Push the SFP transceiver with the lock closed into the slot.



2.4 Installing the antennas

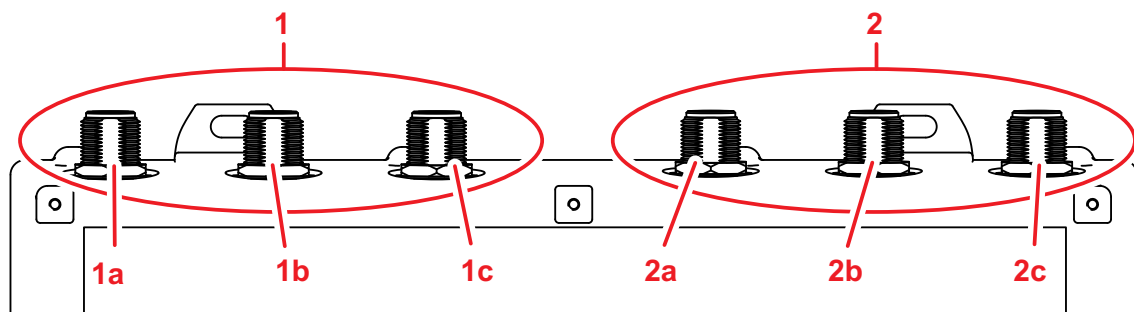

1	alternatively, depending on device variant	For device variants with 2 WLAN modules: 3 × N socket for WLAN module 1
		For device variants with 1 WLAN module: Not present
	1a	Antenna connection 1
	1b	Antenna connection 2
	1c	Antenna connection 3
2	alternatively, depending on device variant	For device variants with 2 WLAN modules: 3 × N socket for WLAN module 2
		For device variants with 1 WLAN module: 3 × N socket for WLAN module 1
	2a	Antenna connection 1
	2b	Antenna connection 2
	2c	Antenna connection 3

Table 8: Antenna connections

If you connect to 2 BAT-F devices antennas to 2 WLAN modules, ensure that there is a distance of at least 2 m between the BAT-F devices.

If you would like to connect several antennas to a WLAN module, align the antennas so that the points of the antennas point away from each other in a star shape.

- Install at least one antenna on the WLAN module that you would like to use.
- Insert the terminating resistors available as accessories into the sockets not being used in order to avoid radio signals from one WLAN module being received by the other WLAN module.

Relevant for use of BAT-ANT-N-MiMo-18N-IP65 with FCC and approval 2, characteristic value H. The devices are labeled as follows:

▶ “FCC ID: U99EWLAN2 and IC: 4019A-EWLAN2”

Connect the BAT-ANT-N-MiMo-18N-IP65 to the WLAN module as follows:

- Connect the antenna port "Ver" with the WLAN antenna port 1.
 - Connect the antenna port "+45 °" with the WLAN antenna port 2.
 - Connect the antenna port "-45 °" with the WLAN antenna port 3.
- Connect the BAT-ANT-N-MiMo-18N-IP65 in this way exclusively.

2.5 Connecting the power supply and the signal contact lines



WARNING

ELECTRIC SHOCK

Before connecting the electrical wires, **always** verify that the requirements listed are complied with.

[See “Requirements for connecting electrical wires” on page 10.](#)

[See “Requirements for connecting the supply voltage” on page 10.](#)

Failure to follow this instruction can result in death, serious injury, or equipment damage.

The supply voltage is electrically isolated from the casing.
You have the option of supplying the supply voltage redundantly, without load distribution.

2.5.1 Supply voltage with the characteristic value C (24 V DC ... 48 V DC)

Perform the following steps for the supply voltage to be connected, or for device variants with 2 supply voltage connections of this type, for **every** supply voltage to be connected.

Type and specification of the supply voltage		Pin assignment on the device	
Rated voltage range DC: 24 V DC ... 48 V DC		P-	Minus terminal of the supply voltage
Voltage range DC incl. maximum tolerances: 18 V DC ... 60 V DC		N.C.	—
		N.C.	—
		P+	Plus terminal of the supply voltage

Table 9: Supply voltage with characteristic value C (24 V DC ... 48 V DC): type and specification of the supply voltage, pin assignment on the device

For **every** supply voltage to be connected, perform the following steps:

- Connect the wires for the supply voltage according to the pin assignment with a suitable socket.

2.5.2 Supply voltage with the characteristic value K (60 V DC ... 250 V DC / 110 V AC ... 230 V AC, 50 Hz ... 60 Hz)

WARNING

ELECTRIC SHOCK

Install this device only in a switch cabinet or in an operating site with restricted access, to which maintenance staff have exclusive access.

Failure to follow this instruction can result in death, serious injury, or equipment damage.

Type of the voltages that can be connected	Specification of the supply voltage	Pin assignment on the device	
DC voltage	Rated voltage range DC: 60 V DC ... 250 V DC Voltage range DC incl. maximum tolerances: 48 V DC ... 320 V DC		PE Protective conductor P+ Plus terminal of the supply voltage P- Minus terminal of the supply voltage
AC voltage	Rated voltage range AC: 110 V AC ... 230 V AC, 50 Hz ... 60 Hz Voltage range AC incl. maximum tolerances: 88 V AC ... 265 V AC, 47 Hz ... 63 Hz		PE Protective conductor L Outer conductor N Neutral conductor

Table 10: Supply voltage with characteristic value K (60 V DC ... 250 V DC / 110 V AC ... 230 V AC, 50 Hz ... 60 Hz): type and specification of the supply voltage, pin assignment on the device

- Connect the wires for the supply voltage and the protective grounding according to the pin assignment with a suitable socket.

2.5.3 Supply voltage with the characteristic value W (24 V DC)

Type and specification of the supply voltage	Pin assignment on the device	
Rated voltage DC: 24 V DC Voltage range DC incl. maximum tolerances: 16.8 V DC ... 32 V DC		P- Minus terminal of the supply voltage N.C. — N.C. — P+ Plus terminal of the supply voltage

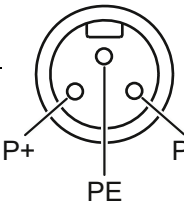
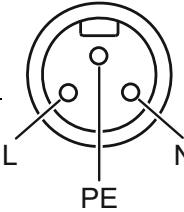
Table 11: Supply voltage with characteristic value W (24 V DC): type and specification of the supply voltage, pin assignment on the device

For **every** supply voltage to be connected, perform the following steps:

- Connect the wires for the supply voltage according to the pin assignment with a suitable socket.

2.5.4 Signal contact

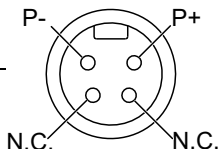
	Pin	Function
	1	Signal contact 2
	2	Signal contact 2
	3	Signal contact 1
	4	Signal contact 1

Table 12: Pin assignment of the signal contact, 4-pin, “A”-coded M12 plug

Only device variants featuring supply voltage with characteristic value C (24 V DC ... 48 V DC), K (60 V DC ... 250 V DC / 110 V AC ... 230 V AC, 50 Hz ... 60 Hz) or W (24 V DC) have a signal contact.

For the signal contacts to be connected, make sure that the following requirements are met:

- ▶ The electrical wires are voltage-free.
- ▶ The connected voltage is limited by a current limitation device or a fuse.
- Observe the electrical threshold values for the signal contact.
[See “General technical data” on page 63.](#)
- Connect the signal contact lines according to the pin assignment with a suitable socket.
- Plug the socket into the M12 plug on the device.
The tightening torque of the locking screw is 5.3 lb-in (0.6 Nm).

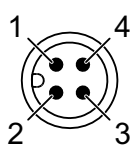
2.6 Operating the device

WARNING

ELECTRIC SHOCK

Before connecting the electrical wires, **always** verify that the requirements listed are complied with.

[See “Requirements for connecting electrical wires” on page 10.](#)

[See “Requirements for connecting the supply voltage” on page 10.](#)

Failure to follow this instruction can result in death, serious injury, or equipment damage.

By connecting the supply voltage via a 7/8" plug or a twisted pair cable (Power over Ethernet), you start the operation of the device.

2.6.1 Connecting the power supply through a 7/8" connector

You find the prescribed tightening torque of the locking screw in General technical data section on page [63](#).

- Plug the socket into the 7/8" connector on the device.
- Enable the supply voltage.

2.6.2 Connecting the power supply through PoE

NOTICE

MATERIAL DAMAGE

In a PoE installation, use only devices that comply with the IEEE 802.3af/at standard.

Failure to follow this instruction can lead to equipment damage.

Only for device variants featuring supply voltage with the characteristic value P (Power supply only through PoE) or W (24 V DC):
By connecting the supply voltage via PoE, you start the operation of the device.

2.7 Connecting data cables

2.7.1 Gigabit combo port

■ 10/100/1000 Mbit/s PoE PD port

Further information:

["10/100/1000 Mbit/s PoE PD port" on page 34](#)

- Connect the data cables according to your requirements.
The tightening torque of the locking screw is 5.3 lb-in (0.6 Nm).

■ 1000 Mbit/s F/O port

Further information:

["1000 Mbit/s F/O port" on page 35](#)

Make sure that you connect LH ports exclusively with LH ports, SX ports exclusively with SX ports, and LX ports exclusively with LX ports.

- Connect the data cables according to your requirements.

2.7.2 10/100/1000 Mbit/s twisted-pair connection (optional)

Further information:

[“10/100/1000 Mbit/s twisted-pair connection \(optional\)” on page 35](#)

- Connect the data cables according to your requirements.
The tightening torque of the locking screw is 5.3 lb-in (0.6 Nm).

3 Making basic settings

The IP parameters must be entered when the device is installed for the first time. The device provides the following options for configuring IP addresses:

- ▶ Input via the V.24 interface
- ▶ Entry via the HiDiscovery protocol in the applications HiDiscovery or Industrial HiVision
- ▶ Configuration via BOOTP
- ▶ Configuration via DHCP (Option 82)
- ▶ AutoConfiguration Adapter

You will find more information in the “User Manual Configuration Guide”.

The manual is available for download on the Internet: <https://www.doc.hirschmann.com>

4 First login (Password change)

Applies to devices with the following software release and later:
HiLCOS 10.12-RU2

To help prevent undesired access to the device, it is imperative that you change the default password during initial setup.

Perform the following steps:

- Open the Graphical User Interface, the Command Line Interface or LANconfig the first time you log on to the device.
- Log on to the device with the default password “private”.
The device prompts you to type in a new password.
Note: When you log on with LANconfig, the device prompts you to type in a new password before your first configuration change.
- Type in your new password.
Choose a password that contains at least 8 characters which includes upper-case characters, lower-case characters, numerical digits and special characters.
- Confirm your new password.

For further information see:

<https://hirschmann-support.belden.com/en/kb/required-password-change-new-procedure-for-first-time-login>

5 Obtain compliance for operation in the European Union

For operation in the European Union, the device must comply with the Radio Equipment Directive (RED) 2014/53/EU. The RED compliance requires compliant operation of the device in the 5 GHz band channels. Compliant operation of the device is achieved by an unchangeable determination of the country setting.

Make the country setting unchangeable using the Command Line Interface (CLI), the graphical user interface or the LANconfig software. You can download the LANconfig software from the Hirschmann product pages (www.hirschmann.com).

Perform the following work steps:

■ Command Line Interface (CLI)

- To access the possible country settings, execute the following command:

```
set Setup/WLAN/Country ?
```

Note: The country setting “Europe” is valid for all European countries. Specific country settings such as “France” or “Germany” include additional country specific channels in comparison to the “Europe” country setting.

The device ignores specific country settings and uses the country setting “Europe” until the RED compliance has been obtained.

- Select the desired country setting with the following command:

```
set Setup/WLAN/Country [Country]
```

Example:

```
set Setup/WLAN/Country France
```

- Execute the following command:

```
> REDcompliance
```

Note: To check the country setting and correct it, type `no`. Then check the country setting with the following command: `ls Setup/WLAN/Country`.

- To obtain RED compliance, type `yes`. This makes the country setting unchangeable. Subsequently, the device restarts.

■ **Graphical user interface**

- Open the **Configuration > Wireless LAN > General** dialog and select the desired country setting.

Note: The country setting “Europe” is valid for all European countries. Specific country settings such as “France” or “Germany” include additional country specific channels in comparison to the “Europe” country setting.

The device ignores specific country settings and uses the country setting “Europe” until the RED compliance has been obtained.

- To confirm your choice, click the “Send” button.
- Open the **Extras > RED compliance** dialog.

Note: To check the country setting and correct it, open the **Configuration > Wireless LAN > General** dialog.

- To obtain RED compliance, click the “Confirm RED compliance” button. This makes the country setting unchangeable. Subsequently, the device restarts.

■ **LANconfig**

- In the LANconfig device overview, highlight the row containing the desired device.
- In the menu bar, select **Device > Configure**.
- Open the **Configuration > Wireless LAN > General** dialog and select the desired country setting.

Note: The country setting “Europe” is valid for all European countries. Specific country settings such as “France” or “Germany” include additional country specific channels in comparison to the “Europe” country setting.

The device ignores specific country settings and uses the country setting “Europe” until the RED compliance has been obtained.

- To confirm your choice, click the “OK” button.
- In the LANconfig device overview, highlight the row containing the desired device.
- In the menu bar, select **Device > RED compliance**.

Note: To check the country setting and correct it, click the “No” button. Then open the **Configuration > Wireless LAN > General** dialog.

- To obtain RED compliance, click the “Yes” button. This makes the country setting unchangeable. Subsequently, the device restarts.

6 Configuring the transmit power

Note: This chapter does **NOT** apply to device variants with approval for the 4.9 GHz band (Approvals 2, characteristic value P). For device variants with approval for the 4.9 GHz band see [“Configuring the transmit power for the 4.9 GHz band” on page 59](#).

Note: The operator of a WLAN radio installation must adhere to the applicable transmission threshold values.

Use the graphical user interface or the LANconfig software. You can download the LANconfig software from the Hirschmann product pages (www.hirschmann.com).

In the graphical user interface, proceed as follows:

- In the menu tree, open the **Configuration > Wireless LAN > General** dialog.
- In the “General” tab, specify in the “General” frame the country in which you install the device, and click the “Send” button.

Note: For devices that are operated in the European Union perform the work steps described in chapter [“Obtain compliance for operation in the European Union” on page 54](#).

- In the menu tree, open the **Configuration > Wireless LAN > General > Physical WLAN settings - Radio** dialog.
- In the “General” tab, click in the “Interface” column the physical WLAN interface to which you connect the antenna.

- Subtract the cable and installed overvoltage protector attenuation from the antenna gain. Enter the calculated value in the “Antenna gain” field.

**Physical WLAN settings
- Radio**

Interface	<input type="text" value="WLAN interface 1"/>
Frequency band	<input type="text" value="2.4 GHz (802.11g/b/n)"/>
Sub-bands	<input type="text" value="1"/>
Channel number	<input type="text" value="Channel 11 (2.462 GHz)"/>
2.4 GHz mode	<input type="text" value="802.11g/b/n (mixed)"/>
5 GHz mode	<input type="text" value="802.11a/n (mixed)"/>
Max. channel bandwidth	<input type="text" value="Auto"/>
Antenna grouping	<input type="text" value="Auto"/>
Antenna gain	<input type="text" value="3"/> dBi (possible values: -128 - 127)
TX power reduction	<input type="text" value="0"/> dB (possible values: 0 - 255)
Access point density	<input type="text" value="Low"/>
Maximum distance	<input type="text" value="0"/> km (possible values: 0 - 65535)
Channel list	<input type="text" value=""/> (max. 48 characters)
Background scan	<input type="text" value="0"/> (possible values: 0 - 2147483647)
Background scan unit	<input type="text" value="seconds"/>
Time of DFS rescan	<input type="text" value=""/> (max. 19 characters)
Number of channels to scan	<input type="text" value="2"/> (possible values: 0 - 1410065407)
Rescan free channels	<input type="text" value="No"/>
Adaptive Noise Immunity	<input type="text" value="On"/>

- To save the value, click the “Send” button.

7 Configuring the transmit power for the 4.9 GHz band

Note: This chapter exclusively applies to device variants with approval for the 4.9 GHz band (Approvals 2, characteristic value P).

Note: The operator of a WLAN radio installation must adhere to the applicable transmission threshold values.

Use the graphical user interface or the LANconfig software. You can download the LANconfig software from the Hirschmann product pages (www.hirschmann.com).

In the graphical user interface, proceed as follows:

- Open the **Configuration > Wireless LAN > General** dialog.
- In the “General” frame in the “Restrict to 4.9GHz operation mode” row, choose the “Enabled” option in the drop-down list.

Note: For devices operating in the 4,9 GHz band according to FCC 47CFR Part 90 Subpart Y the following applies:

For antennas with an antenna gain >9 dBi, the transmit power must be reduced accordingly in the device software. For more detailed information see the following step-by-step instructions.

- Open the **HiLCOS Menu Tree > Setup > Interfaces > WLAN > Radio-Settings** dialog.
- In the “Ifc” column, click the physical WLAN interface to which you connect the antenna.
- In the “Radio-Band” row, choose the “5GHz” option in the drop-down list.
- Subtract the cable and installed overvoltage protector attenuation from the antenna gain. If the value after subtracting the attenuation is ≤ 9 dBi, you do not need to do anything else.

If the value is >9 dBi, proceed as follows:

- Calculate the difference to the maximum permitted antenna gain of 9 dBi. Example calculation for an antenna gain of 14 dBi and an attenuation of 2 dBi:
 - ▶ Step 1 (antenna gain minus attenuation):
 $14 \text{ dBi} - 2 \text{ dBi} = 12 \text{ dBi}$
As the value is >9 dBi, the difference to the maximum permitted 9 dBi must be calculated in Step 2.
 - ▶ Step 2: $12 \text{ dBi} - 9 \text{ dBi} = 3 \text{ dBi}$
- Enter the difference you have calculated in the “Tx-Power-Reduction” field.

Radio-Settings

Ifc	WLAN-1
Radio-Band	5GHz
Subbands	Band-1
Radio-Channel	11 (max. 3 characters)
Channel-List	(max. 48 characters)
2.4GHz-Mode	Auto
5GHz-Mode	Auto
Max.-Channel-Bandwidth	Auto
Force-40MHz	No
Channel-Pairing	11n-compliant
Antenna-Mask	Auto
Tx-Power-Reduction	0 (max. 3 characters)
Maximum-Distance	0 (max. 5 characters)
AP-Density	Low
Background-Scan	0 (max. 10 characters)
Background-Scan-Unit	Seconds
Adaptive-Noise-Immunity	Yes
Allow-PHY-Restarts	Yes
DFS-Rescan-Hours	2 (max. 30 characters)
DFS-Rescan-Flush-Clear-Channels	No
DFS-Rescan-Num-Channels	2 (max. 10 characters)
CAC-Duration	60 (max. 10 characters)
Preferred-DFS-Scheme	EN301893-V1.7
Passive-Scan-Duration	400 (max. 10 characters)

Send Reset

To save the value, click the “Send” button.

8 Maintenance and service

- ▶ When designing this device, Hirschmann largely avoided using high-wear parts. The parts subject to wear and tear are dimensioned to last longer than the lifetime of the product when it is operated normally. Operate this device according to the specifications.
- ▶ Relays are subject to natural wear. This wear depends on the frequency of the switching operations. Check the resistance of the closed relay contacts and the switching function depending on the frequency of the switching operations.
- ▶ Hirschmann is continually working on improving and developing their software. Check regularly whether there is an updated version of the software that provides you with additional benefits. You find information and software downloads on the Hirschmann product pages on the Internet (<http://www.hirschmann.com>).

Note: You find information on settling complaints on the Internet at <http://www.beldensolutions.com/en/Service/Repairs/index.phtml>.

9 Disassembly

9.1 Removing the device

- Disconnect the data cables.
- Disable the supply voltage.
- Disconnect the power supply cables and signal lines.
- Remove the antennas.
- Disconnect the grounding.

9.2 Removing an SFP transceiver (optional)

To disassemble SFP transceivers, you require the SFP mounting tool available as an accessory .

See [“Accessories” on page 82.](#)



Figure 1: SFP mounting tool

1 – mounting side

2 – barbed hooks

3 – disassembly side

- Insert the SFP mounting tool so into the SFP transceiver that the barbed hooks point to the locking handle of the SFP transceivers.
- Gently press the SFP mounting tool in the direction of the lock so that the barbed hooks link into the strap.
- Pull the SFP transceiver out of the slot using the mounting tool.

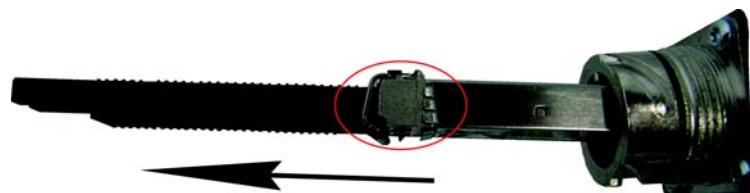

- Close the slot with the protection cap.

10 Technical data

10.1 General technical data

Weight	Device variants featuring supply voltage with characteristic value P (Power supply only through PoE)	approx. 98.56 oz (2800 g)
	Device variants featuring supply voltage with characteristic value C (24 V DC ... 48 V DC) or K (60 V DC ... 250 V DC / 110 V AC ... 230 V AC, 50 Hz ... 60 Hz)	approx. 114.64 oz (3250 g)
	Device variants featuring supply voltage with characteristic value W (24 V DC) and approvals 1 with the characteristic value I, M or 9	approx. 105.82 oz (3000 g)
	Device variants featuring supply voltage with characteristic value W (24 V DC) and approvals 1 with the characteristic value F or G	approx. 145.33 oz (4120 g)
	Device variants featuring supply voltage with characteristic value W (24 V DC) and approvals 1 with characteristic value K	approx. 109.35 oz (3100 g)
Supply voltage with the characteristic value C	Power supply solely through a 7/8" connector	
	Rated voltage range DC:	24 V DC ... 48 V DC Class 2
	Voltage range DC incl. maximum tolerances:	18 V DC ... 60 V DC
	Connection type	4-pin, 7/8" connector
		Tightening torque of the locking screw 22 lb-in (2.5 Nm)
	Power loss buffer	>10 ms at 20.4 V DC
	Overload current protection on the device	Non-replaceable fuse
	Back-up fuse	Nominal rating: Max. 6.3 A Characteristic: slow blow
Peak inrush current	14 A	

Supply voltage with the characteristic value K	Power supply solely through a 7/8" connector	
	Rated voltage range AC:	110 V AC ... 230 V AC, 50 Hz ... 60 Hz
	Voltage range including maximum tolerances	88 V AC ... 265 V AC, 47 Hz ... 63 Hz
	Rated voltage range	60 V DC ... 250 V DC
	Voltage range incl. maximum tolerances	48 V DC ... 320 V DC
	Connection type	3-pin, 7/8" connector
		Tightening torque of the locking screw 22 lb-in (2.5 Nm)
	Power loss buffer	>10 ms at 98 V AC
	Overload current protection on the device	Non-replaceable fuse
	Back-up fuse for each voltage input	Nominal rating: 2.5 A Characteristic: slow blow
Peak inrush current	14 A	
Supply voltage with the characteristic value P	Power supply exclusively via PoE	
Supply voltage with the characteristic value W	Power supply through a 7/8" connector	
	Rated voltage	24 V DC Class 2
	Voltage range incl. maximum tolerances	16.8 V DC ... 32 V DC
	Connection type	4-pin, 7/8" connector
		Tightening torque of the locking screw 22 lb-in (2.5 Nm)
	Power loss buffer	>10 ms at 20.4 V DC
	Overload current protection on the device	Non-replaceable fuse
	Back-up fuse	Nominal rating: Max. 6.3 A Characteristic: slow blow
Peak inrush current	14 A	
Climatic conditions during operation	Ambient air temperature ^a	Devices with operating temperature characteristic value S (Standard): +32 °F ... +140 °F (0 °C ... +60 °C) Devices with operating temperature characteristic value E and T (extended): -40 °F ... +158 °F (-40 °C ... +70 °C) ^b Devices with operating temperature characteristic value K (Extended with Conformal Coating, approvals 1 with the characteristic value K): -40 °F ... +131 °F (-40 °C ... +55 °C)
	Humidity	10 % ... 95 %
	Air pressure	up to 6562 ft (2000 m; 795 hPa), higher altitudes upon request max. 1060 hPa (-1312 ft; -400 m)

Climatic conditions during storage	Minimum clearance around the device	Top and bottom device side: 3.94 in (10 cm) Left and right device side: 0.79 in (2 cm)
	Ambient air temperature ^a	-40 °F ... +185 °F (-40 °C ... +85 °C)
	Humidity	10 % ... 95 %
	Air pressure	min. 700 hPa (+9842 ft; +3000 m) max. 1060 hPa (-1312 ft; -400 m)
Signal contact "FAULT"	Switching current	max. 1 A, SELV
	Switching voltage	Supply voltage with characteristic value C (24 V DC ... 48 V DC) and K (60 V DC ... 250 V DC / 110 V AC ... 230 V AC, 50 Hz ... 60 Hz): max. 60 V DC or max. 30 V AC, SELV Supply voltage with the characteristic value W: max. 30 V DC, SELV
Pollution degree		2
Protection classes	Laser protection	Class 1 in compliance with IEC 60825-1
	Degree of protection	IP65/67

- a. Temperature of the ambient air at a distance of 2 in (5 cm) from the device
b. Use SFP transceivers with the "EEC" extension only, otherwise the standard temperature range applies.

10.2 Dimension drawings

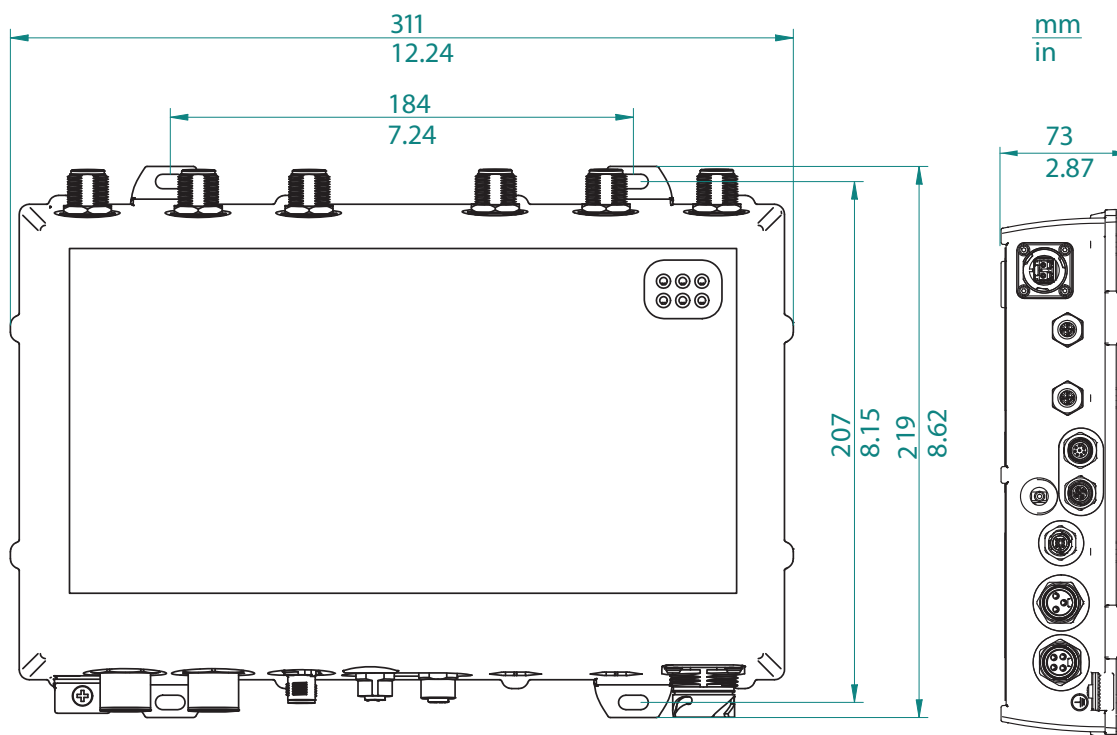

Figure 2: Dimensions of device variants and distance between suspensions.

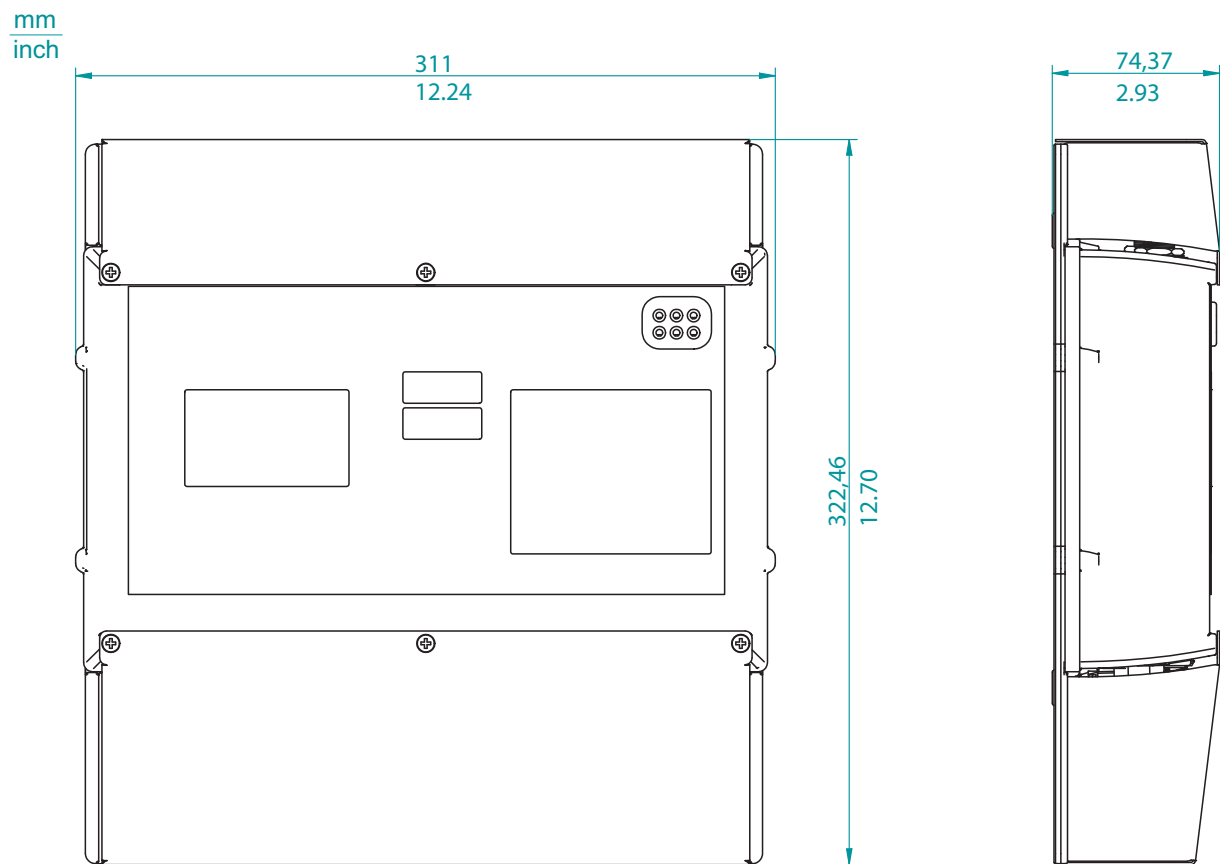

Figure 3: Dimensions of the device variants with impact protection.

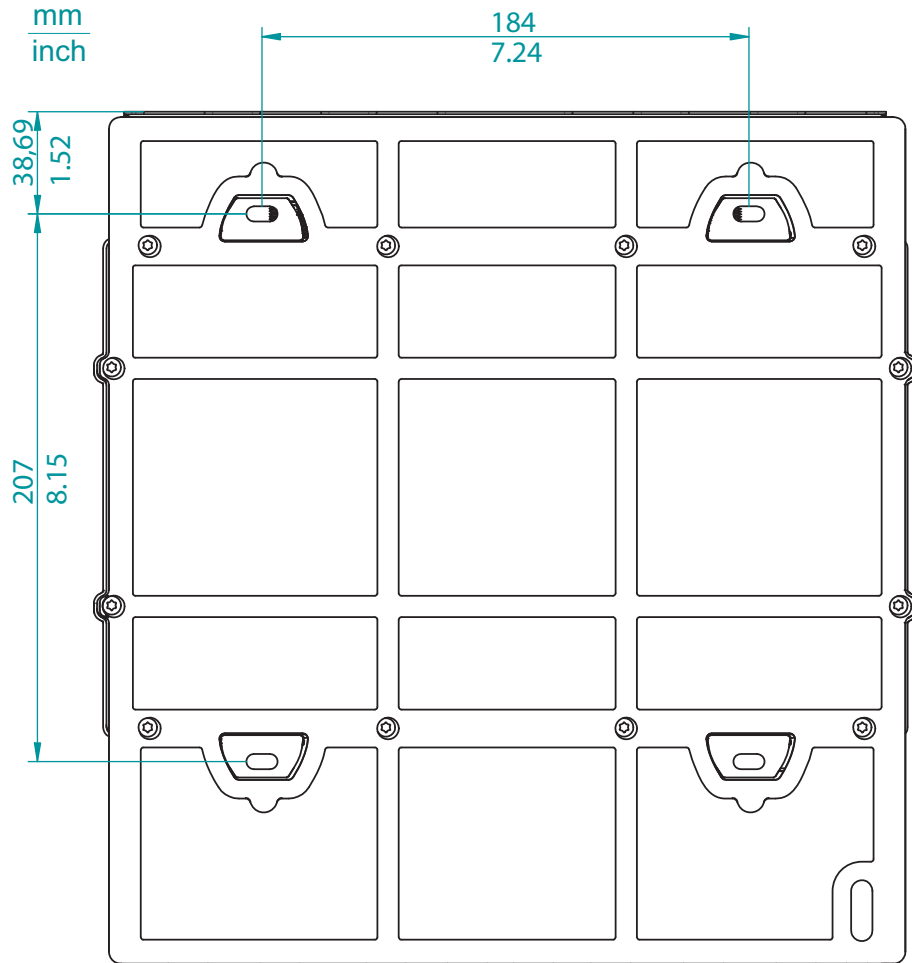

Figure 4: Distances of the suspension with impact protection.

10.3 Radio technology

Antenna connection	For each WLAN module: 3 × N socket
Range	Depending on the antenna used, frequency range and data rate
Encryption	<ul style="list-style-type: none">▶ IEEE 802.11i/WPA2 with passphrase or IEEE 802.1x and hardware-accelerated AES▶ Closed Network▶ WEP 64^a▶ WEP 128^b▶ WEP 152^c▶ User authentication▶ 802.1x/EAP▶ LEPS▶ WPA1/TKIP^d▶ For more information, see the HiLCOS data sheet.
Frequency range	<ul style="list-style-type: none">▶ Support of 2.4 GHz: 2412 MHz to 2472 MHz (for FCC: 2412 MHz to 2462 MHz)▶ Support of 5 GHz: 5180 MHz to 5825 MHz (for FCC: 5180 MHz to 5240 MHz and 5745 MHz to 5825 MHz)▶ Support of 4.9 GHz (for FCC only): 4940 MHz to 4990 MHz
Modulation technology	<ul style="list-style-type: none">▶ OFDM: BPSK, QPSK, 16-QAM, 64-QAM▶ DSSS/CCK, DSSS/DBPSK, DSSS/DQPSK
Radio topology	WLAN Access-Point, Bridge-, Router-, Point-to-Point-, Client-, Client-Bridge-Mode

- a. With encryptions of the type TKIP and WEP, the device falls back on IEEE 802.11b/g or IEEE 802.11a.
- b. With encryptions of the type TKIP and WEP, the device falls back on IEEE 802.11b/g or IEEE 802.11a.
- c. With encryptions of the type TKIP and WEP, the device falls back on IEEE 802.11b/g or IEEE 802.11a.
- d. With encryptions of the type TKIP and WEP, the device falls back on IEEE 802.11b/g or IEEE 802.11a.

10.4 Roaming

- ▶ IEEE 802.11F (Inter-Access Point Protocol)
- ▶ IEEE 802.11r (Fast Roaming)
- ▶ PMK caching
- ▶ Pre authentication
- ▶ OKC (Opportunistic key caching)

10.5 Receiving sensitivity, transmit power, and data rate of the WLAN module version EWLAN1 (Approvals 2, characteristic value M or 9)

The values shown in the following tables are the maximum values of the WLAN module version EWLAN1. The values are in no case to be perceived as a guaranteed property of the overall product. For some country profiles, the module reduces data rate and transmit power automatically. The reason for this are national standards.

10.5.1 IEEE 802.11b

IEEE 802.11b		
Frequency range 2.412 GHz to 2.472 GHz (for FCC: 2.412 GHz to 2.462 GHz)		
Data rate	Typical transmit power	Typical receiving sensitivity
1 Mbit/s	19 dBm	-94 dBm
11 Mbit/s	19 dBm	-94 dBm

Table 13: IEEE 802.11b, Frequency range 2.412 GHz to 2.472 GHz (for FCC: 2.412 GHz to 2.462 GHz)

10.5.2 IEEE 802.11g

IEEE 802.11g		
Frequency range 2.412 GHz to 2.472 GHz (for FCC: 2.412 GHz to 2.462 GHz)		
Data rate	Typical transmit power	Typical receiving sensitivity
6 Mbit/s	22 dBm	-94 dBm
9 Mbit/s	22 dBm	-94 dBm
12 Mbit/s	22 dBm	-90 dBm
18 Mbit/s	22 dBm	-89 dBm
24 Mbit/s	22 dBm	-85 dBm
36 Mbit/s	21 dBm	-82 dBm
48 Mbit/s	20 dBm	-78 dBm
54 Mbit/s	19 dBm	-77 dBm

Table 14: IEEE 802.11g, Frequency range 2.412 GHz to 2.472 GHz (for FCC: 2.412 GHz to 2.462 GHz)

10.5.3 IEEE 802.11a

IEEE 802.11a

Frequency range 5.180 GHz to 5.825 GHz (for FCC: 5.180 GHz to 5.240 GHz and 5.745 GHz to 5.825 GHz)

Data rate	Typical transmit power ^a	Typical receiving sensitivity
6 Mbit/s	16 dBm	-93 dBm
9 Mbit/s	16 dBm	-93 dBm
12 Mbit/s	16 dBm	-93 dBm
18 Mbit/s	16 dBm	-91 dBm
24 Mbit/s	16 dBm	-88 dBm
36 Mbit/s	15 dBm	-84 dBm
48 Mbit/s	13 dBm	-80 dBm
54 Mbit/s	12 dBm	-79 dBm

Table 15: IEEE 802.11a, Frequency range 5.180 GHz to 5.825 GHz (for FCC: 5.180 GHz to 5.240 GHz and 5.745 GHz to 5.825 GHz)

- a. The typical transmit power was reduced by 6 dB on channels 36, 40, 44, 48 and 149 to be compliant with FCC regulations for all modulations.

10.5.4 IEEE 802.11n

IEEE 802.11n

Frequency range 2.412 GHz to 2.472 GHz (for FCC: 2.412 GHz to 2.462 GHz)

Coding	Typical transmit power	Typical receiving sensitivity
MCS 0	18 dBm	-87 dBm
MCS 1	18 dBm	-90 dBm
MCS 2	18 dBm	-86 dBm
MCS 3	18 dBm	-82 dBm
MCS 4	18 dBm	-79 dBm
MCS 5	16 dBm	-75 dBm
MCS 6	16 dBm	-73 dBm
MCS 7	15 dBm	-72 dBm
MCS 8	22 dBm	-87 dBm
MCS 9	21 dBm	-90 dBm
MCS 10	22 dBm	-86 dBm
MCS 11	21 dBm	-82 dBm
MCS 12	16 dBm	-79 dBm
MCS 13	16 dBm	-75 dBm

Table 16: IEEE 802.11n, Frequency range 2.412 GHz to 2.472 GHz (for FCC: 2.412 GHz to 2.462 GHz)

IEEE 802.11n		
Frequency range 2.412 GHz to 2.472 GHz (for FCC: 2.412 GHz to 2.462 GHz)		
Coding	Typical transmit power	Typical receiving sensitivity
MCS 14	15 dBm	-73 dBm
MCS 15	15 dBm	-72 dBm
MCS 16	23 dBm	-87 dBm
MCS 17	23 dBm	-90 dBm
MCS 18	23 dBm	-86 dBm
MCS 19	23 dBm	-82 dBm
MCS 20	16 dBm	-79 dBm
MCS 21	17 dBm	-75 dBm
MCS 22	17 dBm	-73 dBm
MCS 23	16 dBm	-72 dBm

Table 16: IEEE 802.11n, Frequency range 2.412 GHz to 2.472 GHz (for FCC: 2.412 GHz to 2.462 GHz)

IEEE 802.11n		
Frequency range 5.180 GHz to 5.825 GHz (for FCC: 5.180 GHz to 5.240 GHz and 5.745 GHz to 5.825 GHz)		
Coding	Typical transmit power^a	Typical receiving sensitivity
MCS 0	17 dBm	-92 dBm
MCS 1	17 dBm	-91 dBm
MCS 2	17 dBm	-89 dBm
MCS 3	17 dBm	-84 dBm
MCS 4	17 dBm	-81 dBm
MCS 5	15 dBm	-77 dBm
MCS 6	14 dBm	-75 dBm
MCS 7	14 dBm	-73 dBm
MCS 8	20 dBm	-92 dBm
MCS 9	20 dBm	-91 dBm
MCS 10	19 dBm	-89 dBm
MCS 11	20 dBm	-84 dBm
MCS 12	18 dBm	-81 dBm
MCS 13	15 dBm	-77 dBm
MCS 14	15 dBm	-75 dBm

Table 17: IEEE 802.11n, Frequency range 5.180 GHz to 5.825 GHz (for FCC: 5.180 GHz to 5.240 GHz and 5.745 GHz to 5.825 GHz)

IEEE 802.11n**Frequency range 5.180 GHz to 5.825 GHz (for FCC: 5.180 GHz to 5.240 GHz and 5.745 GHz to 5.825 GHz)**

Coding	Typical transmit power^a	Typical receiving sensitivity
MCS 15	14 dBm	-73 dBm
MCS 16	21 dBm	-92 dBm
MCS 17	21 dBm	-91 dBm
MCS 18	21 dBm	-89 dBm
MCS 19	21 dBm	-84 dBm
MCS 20	16 dBm	-81 dBm
MCS 21	15 dBm	-77 dBm
MCS 22	14 dBm	-75 dBm
MCS 23	14 dBm	-73 dBm

Table 17: IEEE 802.11n, Frequency range 5.180 GHz to 5.825 GHz (for FCC: 5.180 GHz to 5.240 GHz and 5.745 GHz to 5.825 GHz)

- a. The typical transmit power was reduced by 6 dB on channels 36, 40, 44, 48 and 149 to be compliant with FCC regulations for all modulations.

10.6 Receiving sensitivity, transmit power, and data rate of the WLAN module version EWLAN1 for device variants with approval for the 4.9 GHz band (Approvals 2, characteristic value P)

Applies exclusively to WLAN module version EWLAN1 for device variants with approval for the 4.9 GHz band (Approvals 2, characteristic value P) according to FCC 47CFR Part 90 Subpart Y.

The values shown in the following tables show measured maximum values in the lowest channel of the respective bandwidth with 1 active antenna. The values are in no case to be perceived as a guaranteed property of the overall product. Depending on the settings, the module automatically reduces the data rate and transmit power according to FCC 47CFR Part 90 Subpart Y.

10.6.1 IEEE 802.11a, Bandwidth 5 MHz

IEEE 802.11a Frequency range 4.940 GHz to 4.990 GHz Bandwidth 5 MHz	
Data rate	Typical transmit power
1.5 Mbit/s	13 dBm
2.25 Mbit/s	13 dBm
3 Mbit/s	13 dBm
4.5 Mbit/s	13 dBm
6 Mbit/s	13 dBm
9 Mbit/s	12 dBm
12 Mbit/s	12 dBm
13.5 Mbit/s	11 dBm

Table 18: IEEE 802.11a, Frequency range 4.940 GHz to 4.990 GHz, Bandwidth 5 MHz, Channels 218-227

10.6.2 IEEE 802.11a, Bandwidth 10 MHz

IEEE 802.11a Frequency range 4.940 GHz to 4.990 GHz Bandwidth 10 MHz	
Data rate	Typical transmit power
3 Mbit/s	14 dBm
4.5 Mbit/s	14 dBm
6 Mbit/s	14 dBm

Table 19: IEEE 802.11a, Frequency range 4.940 GHz to 4.990 GHz, Bandwidth 10 MHz, Channels 19-27

IEEE 802.11a	
Frequency range 4.940 GHz to 4.990 GHz	
Bandwidth 10 MHz	
Data rate	Typical transmit power
9 Mbit/s	14 dBm
12 Mbit/s	14 dBm
18 Mbit/s	13 dBm
24 Mbit/s	12 dBm
27 Mbit/s	11 dBm

Table 19: IEEE 802.11a, Frequency range 4.940 GHz to 4.990 GHz, Bandwidth 10 MHz, Channels 19-27

10.6.3 IEEE 802.11a, Bandwidth 20 MHz

IEEE 802.11a	
Frequency range 4.940 GHz to 4.990 GHz	
Bandwidth 20 MHz	
Data rate	Typical transmit power
6 Mbit/s	14 dBm
9 Mbit/s	14 dBm
12 Mbit/s	14 dBm
18 Mbit/s	13 dBm
24 Mbit/s	14 dBm
36 Mbit/s	13 dBm
48 Mbit/s	13 dBm
54 Mbit/s	12 dBm

Table 20: IEEE 802.11a, Frequency range 4.940 GHz to 4.990 GHz, Bandwidth 20 MHz, Channels 20-26

10.7 Receiving sensitivity, transmit power, and data rate of the WLAN module version EWLAN2 for high-gain antennas (Approvals 2, characteristic value H)

The values shown in the following tables are the maximum values of the WLAN module version EWLAN2 for high-gain antennas. The values are in no case to be perceived as a guaranteed property of the overall product. For some country profiles, the module reduces data rate and transmit power automatically. The reason for this are national standards.

10.7.1 IEEE 802.11b

IEEE 802.11b		
Frequency range 2.412 GHz to 2.472 GHz (for FCC: 2.412 GHz to 2.462 GHz)		
Data rate	Typical transmit power	Typical receiving sensitivity
1 Mbit/s	19 dBm	-94 dBm
11 Mbit/s	19 dBm	-94 dBm

Table 21: IEEE 802.11b, Frequency range 2.412 GHz to 2.472 GHz (for FCC: 2.412 GHz to 2.462 GHz)

10.7.2 IEEE 802.11g

IEEE 802.11g		
Frequency range 2.412 GHz to 2.472 GHz (for FCC: 2.412 GHz to 2.462 GHz)		
Data rate	Typical transmit power	Typical receiving sensitivity
6 Mbit/s	22 dBm	-94 dBm
9 Mbit/s	22 dBm	-94 dBm
12 Mbit/s	22 dBm	-90 dBm
18 Mbit/s	22 dBm	-89 dBm
24 Mbit/s	22 dBm	-85 dBm
36 Mbit/s	21 dBm	-82 dBm
48 Mbit/s	20 dBm	-78 dBm
54 Mbit/s	19 dBm	-77 dBm

Table 22: IEEE 802.11g, Frequency range 2.412 GHz to 2.472 GHz (for FCC: 2.412 GHz to 2.462 GHz)

10.7.3 IEEE 802.11a

IEEE 802.11a

Frequency range 5.180 GHz to 5.825 GHz (for FCC: 5.180 GHz to 5.240 GHz and 5.745 GHz to 5.825 GHz)

Data rate	Typical transmit power	Typical receiving sensitivity
6 Mbit/s	10 dBm	-93 dBm
9 Mbit/s	10 dBm	-93 dBm
12 Mbit/s	10 dBm	-93 dBm
18 Mbit/s	10 dBm	-91 dBm
24 Mbit/s	10 dBm	-88 dBm
36 Mbit/s	9 dBm	-84 dBm
48 Mbit/s	7 dBm	-80 dBm
54 Mbit/s	6 dBm	-79 dBm

Table 23: IEEE 802.11a, Frequency range 5.180 GHz to 5.825 GHz (for FCC: 5.180 GHz to 5.240 GHz and 5.745 GHz to 5.825 GHz)

10.7.4 IEEE 802.11n

IEEE 802.11n

Frequency range 2.412 GHz to 2.472 GHz (for FCC: 2.412 GHz to 2.462 GHz)

Coding	Typical transmit power	Typical receiving sensitivity
MCS 0	18 dBm	-87 dBm
MCS 1	18 dBm	-90 dBm
MCS 2	18 dBm	-86 dBm
MCS 3	18 dBm	-82 dBm
MCS 4	18 dBm	-79 dBm
MCS 5	16 dBm	-75 dBm
MCS 6	16 dBm	-73 dBm
MCS 7	15 dBm	-72 dBm
MCS 8	22 dBm	-87 dBm
MCS 9	21 dBm	-90 dBm
MCS 10	22 dBm	-86 dBm
MCS 11	21 dBm	-82 dBm
MCS 12	16 dBm	-79 dBm
MCS 13	16 dBm	-75 dBm
MCS 14	15 dBm	-73 dBm

Table 24: IEEE 802.11n, Frequency range 2.412 GHz to 2.472 GHz (for FCC: 2.412 GHz to 2.462 GHz)

IEEE 802.11n		
Frequency range 2.412 GHz to 2.472 GHz (for FCC: 2.412 GHz to 2.462 GHz)		
Coding	Typical transmit power	Typical receiving sensitivity
MCS 15	15 dBm	-72 dBm
MCS 16	23 dBm	-87 dBm
MCS 17	23 dBm	-90 dBm
MCS 18	23 dBm	-86 dBm
MCS 19	23 dBm	-82 dBm
MCS 20	16 dBm	-79 dBm
MCS 21	17 dBm	-75 dBm
MCS 22	17 dBm	-73 dBm
MCS 23	16 dBm	-72 dBm

Table 24: IEEE 802.11n, Frequency range 2.412 GHz to 2.472 GHz (for FCC: 2.412 GHz to 2.462 GHz)

IEEE 802.11n		
Frequency range 5.180 GHz to 5.825 GHz (for FCC: 5.180 GHz to 5.240 GHz and 5.745 GHz to 5.825 GHz)		
Coding	Typical transmit power	Typical receiving sensitivity
MCS 0	11 dBm	-92 dBm
MCS 1	11 dBm	-91 dBm
MCS 2	11 dBm	-89 dBm
MCS 3	11 dBm	-84 dBm
MCS 4	11 dBm	-81 dBm
MCS 5	9 dBm	-77 dBm
MCS 6	8 dBm	-75 dBm
MCS 7	8 dBm	-73 dBm
MCS 8	7 dBm	-92 dBm
MCS 9	7 dBm	-91 dBm
MCS 10	6 dBm	-89 dBm
MCS 11	7 dBm	-84 dBm
MCS 12	5 dBm	-81 dBm
MCS 13	2 dBm	-77 dBm
MCS 14	2 dBm	-75 dBm
MCS 15	1 dBm	-73 dBm

Table 25: IEEE 802.11n, Frequency range 5.180 GHz to 5.825 GHz (for FCC: 5.180 GHz to 5.240 GHz and 5.745 GHz to 5.825 GHz)

IEEE 802.11n		
Frequency range 5.180 GHz to 5.825 GHz (for FCC: 5.180 GHz to 5.240 GHz and 5.745 GHz to 5.825 GHz)		
Coding	Typical transmit power	Typical receiving sensitivity
MCS 16	8 dBm	-92 dBm
MCS 17	8 dBm	-91 dBm
MCS 18	8 dBm	-89 dBm
MCS 19	8 dBm	-84 dBm
MCS 20	3 dBm	-81 dBm
MCS 21	2 dBm	-77 dBm
MCS 22	1 dBm	-75 dBm
MCS 23	1 dBm	-73 dBm

Table 25: IEEE 802.11n, Frequency range 5.180 GHz to 5.825 GHz (for FCC: 5.180 GHz to 5.240 GHz and 5.745 GHz to 5.825 GHz)

10.8 EMC and immunity

EMC interference immunity		
EN 61000-4-2	Electrostatic discharge	
	Contact discharge, test level 4	±8 kV
	Air discharge, test level 4	±15 kV
EN 61000-4-3	Electromagnetic field	
	80 MHz ... 1000 MHz	20 V/m
	1400 MHz ... 2700 MHz	10 V/m
EN 61000-4-4	Fast transients (burst), test level 4	
	DC power line	±4 kV
	AC Power Line	±4 kV
	Data line	±4 kV
EN 61000-4-5	Voltage surges	
	DC power line	±2 kV line/ground; ±1 kV line/line
	AC Power Line	±4 kV line/ground; ±2 kV line/line
	Data line, shielded	±4 kV line/ground
	Data line, unshielded	±2 kV line/ground
	Data line, unshielded	±1 kV line/line
EN 61000-4-6	Conducted interference voltages, test level 3	
	150 kHz ... 80 MHz	10 V
EN 61000-4-9	Pulse magnetic fields	300 A/m

EMC interference emission	
EN 55032	Class B
FCC 47 CFR Part 15	Class A

Immunity	
Vibration	IEC 60068-2-6 Test FC test level according to IEC 61131-2
Shock	IEC 60068-2-27 Test Ea test level in accordance with IEC 61131-2, EN 50155

10.9 Network range

Note: The line lengths specified for the transceivers apply for the respective fiber data (fiber attenuation and Bandwidth Length Product (BLP)/ Dispersion).

Product code M-SFP-...	Wave length	Fiber	System attenuation	Example for F/O cable length ^a	Fiber attenuation	BLP ^b / Dispersion
-SX/LC...	MM 850 nm	50/125 µm	0 dB ... 7.5 dB	0 mi ... 0.34 mi (0 km ... 0.55 km)	3.0 dB/km	400 MHz×km
-SX/LC...	MM 850 nm	62.5/125 µm	0 dB ... 7.5 dB	0 mi ... 0.17 mi (0 km ... 0.275 km)	3.2 dB/km	200 MHz×km
-LX/LC...	MM 1310 nm ^c	50/125 µm	0 dB ... 10.5 dB	0 mi ... 0.34 mi (0 km ... 0.55 km)	1.0 dB/km	800 MHz×km
-LX/LC...	MM 1310 nm ^d	62.5/125 µm	0 dB ... 10.5 dB	0 mi ... 0.34 mi (0 km ... 0.55 km)	1.0 dB/km	500 MHz×km
-LX/LC...	SM 1310 nm	9/125 µm	0 dB ... 10.5 dB	0 mi ... 12.43 mi (0 km ... 20 km) ^e	0.4 dB/km	3.5 ps/(nm×km)
-LH/LC...	LH 1550 nm	9/125 µm	5 dB ... 22 dB	14.29 mi ... 49.71 mi (23 km ... 80 km)	0.25 dB/km	19 ps/(nm×km)

Table 26: F/O port 1000BASE-FX (SFP fiber optic Gigabit Ethernet Transceiver)

Product code M-SFP-...	Wave length	Fiber	System attenuation	Example for F/O cable length ^a	Fiber attenuation	BLP ^b / Dispersion
-LH+/LC	LH	1550 nm	9/125 μm	15 dB ... 30 dB	44.12 mi ... 67.11 mi (71 km ... 108 km)	0.25 dB/km 19 ps/(nm×km)
-LH+/LC	LH	1550 nm	9/125 μm	15 dB ... 30 dB	44.12 mi ... 79.54 mi (71 km ... 128 km)	0.21 dB/km (typically) 19 ps/(nm×km)

Table 26: F/O port 100BASE-FX (SFP fiber optic Gigabit Ethernet Transceiver)

- a. Including 3 dB system reserve when compliance with the fiber data is observed.
- b. Using the bandwidth-length product is inappropriate for expansion calculations.
- c. With F/O adapter compliant with IEEE 802.3-2002 Clause 38 (single-mode fiber offset-launch mode conditioning patch cord).
- d. With F/O adapter compliant with IEEE 802.3-2002 Clause 38 (single-mode fiber offset-launch mode conditioning patch cord).
- e. Including 2.5 dB system reserve when compliance with the fiber data is observed.

MM = Multimode, SM = Singlemode, LH = Singlemode Longhaul

10/100/1000 Mbit/s twisted pair port	
Length of a twisted pair segment	max. 328 ft (100 m) (for Cat5e cable)

Table 27: Network range: 10/100/1000 Mbit/s twisted pair port

10.10 Power consumption/power output

Conditions	Maximum power consumption	Power output
When equipped with 1 WLAN module	12.95 W	44.19 Btu (IT)/h
When equipped with 2 WLAN modules	17.5 W	59.71 Btu (IT)/h

11 Scope of delivery, order numbers and accessories

■ Scope of delivery

Number	Article
1 ×	Device
1 ×	Safety and general information sheet
1 ×	EU Declaration of Conformity
1 ×	Terminal cable: M12 plug, 8-pin on DB9 socket
3 × per WLAN module	3-dBi dipole dual-band antennas for initial operation
2 ×	Power supply plug, for cable diameters of 0.24 in to 0.32 in (6 mm to 8 mm; model dependent on the characteristic value of the socket) You find power supply plugs with a larger thread here: "Accessories" on page 82
1 × or 2 × (depending on the device variant)	"X"-coded M12 plug
2 × premounted	50 Ω terminating resistor for sealing unused antenna connections (exclusively for device variants with 1 wireless module)
3 × premounted	50 Ω terminating resistor for sealing unused antenna connections (exclusively for device variants with 2 wireless modules)
2 × premounted	Protection cap (7/8", plastic) for supply voltage connection
1 × per WLAN module premounted	Transport protection cap (plastic) for N socket
1 × premounted	Protection cap (7/8", plastic) for SFP slot
1 × premounted	Protection screw (M12, metal) for signal contact
3 × or 4 × premounted (depending on the device variant)	Protection screw (M12, metal) for interfaces

Figure 5: Scope of delivery for device variants featuring Configuration with the characteristic value Z

Number	Article
1 ×	Device
1 ×	Safety and general information sheet
1 ×	EU Declaration of Conformity
1 ×	Power supply plug, for cable diameters of 0.24 in to 0.32 in (6 mm to 8 mm; model dependent on the characteristic value of the socket) You find power supply plugs with a larger thread here: "Accessories" on page 82
3 × per WLAN module premounted	Transport protection cap (plastic) for N socket
1 × premounted	Protection cap (7/8", plastic) for SFP slot
1 × premounted	Protection cap (7/8", plastic) for supply voltage connection
1 × premounted	Protection cap (7/8", plastic) for supply voltage connection
1 × premounted	Protection screw (M12, plastic) for signal contact
3 × or 4 × premounted (depending on the device variant)	Protection screw (M12, plastic) for interfaces

Figure 6: Scope of delivery for device variants featuring Configuration with the characteristic value 9

■ Accessories

Note that products recommended as accessories may have different characteristics to those of the device, which may limit the application range of the overall system. For example, if you add an accessory with IP20 to a device with IP65, the degree of protection of the overall system is reduced to IP20.

To sustain the IP65/67 suitability for your device, use the accessories with IP65/67 properties exclusively.

The following accessory parts are not suitable for use within IP65/67 areas:

- ▶ RJ45 adapters
- ▶ Terminal cable

For reliable receive power and transmission power, you require antennas that pertain to your application case.

The "Antenna Guide" document provides an overview of the antennas that can be used as well as the suitable antenna accessories.

The manual is available for download on the Internet: <https://www.doc.hirschmann.com>

Gigabit Ethernet SFP transceiver	Order number
M-SFP-SX/LC	943 014-001
M-SFP-SX/LC-EEC	943 896-001

Gigabit Ethernet SFP transceiver	Order number
M-SFP-LX/LC	943 015-001
M-SFP-LX/LC-EEC	943 897-001
M-SFP-LH/LC	943 042-001
M-SFP-LH/LC-EEC	943 898-001
M-SFP-LH+/LC	943 049-001
Other accessories	
Order number	Order number
0986 EMC 600, field-attachable M12 plug for Gigabit Ethernet data cables	Available at ICOS 934 637-032
0986 EMC 102, field-attachable M12 plug for Fast Ethernet data cables	Available at Lumberg Automation 71327
50 Ω terminating resistors for sealing unused antenna connections, N (10 pieces)	942 118-001
7/8" plug for supply voltage with characteristic value K (60 V DC ... 250 V DC / 110 V AC ... 230 V AC, 50 Hz ... 60 Hz), for cable diameters 0.24 in ... 0.32 in (6 mm ... 8 mm)	942 086-003
7/8" plug for supply voltage with characteristic value K (60 V DC ... 250 V DC / 110 V AC ... 230 V AC, 50 Hz ... 60 Hz), for cable diameters 0.32 in to 0.39 in (8 mm bis 10 mm)	Available at Lumberg Automation: 11206
7/8" plug for supply voltage with characteristic value W (24 V DC) and C (24 V DC ... 48 V DC), for cable diameters 0.24 in ... 0.32 in (6 mm ... 8 mm)	942 086-004
7/8" plug for supply voltage with characteristic value W (24 V DC) and C (24 V DC ... 48 V DC), for cable diameters 0.32 in to 0.39 in (8 mm bis 10 mm)	Available at Lumberg Automation: 11216
Antenna cable BAT-CLB-2 N m-f	943 903-514
AutoConfiguration Adapter ACA21-M12 (EEC)	943 913-003
AutoConfiguration Adapter ACA22-M12 (EEC)	942 125-001
BAT-ANT-N-3AGN-IP67 (10 pcs.)	942 110-001
BAT-ANT-Protector m-f	943 903-373
EM12S, field-attachable M12 plug for Fast Ethernet data cables	934 445-001
Pole mounting set for OpenBAT device	942 116-001
Network management software Industrial HiVision	943 156-xxx
PoE power supply unit PC150/36V/48V-IP67, supply voltage 16.8 V DC to 64 V DC	943 968-001
PoE power supply unit PC150/72 V/48V-IP67, supply voltage 50.4 V DC to 154 V DC	943 968-101
SFP mounting tool for IP67 socket	942 079-001
Plug casing for IP67 V1 plug acc. to IEC 61076-3-106 (variant 1)	Available at BTR NETCOM GmbH
Terminal cable: M12 plug, 8-pin on DB9 socket	942 087-001
Protection screw for M12 socket, metal, IP65/67 (25 pieces)	942 057-001
Protection screw for M12 plug, metal, IP65/67 (10 pieces)	942 115-001
Protection cap for 7/8" plug, metal, IP67 (10 pieces)	942 111-001

12 Underlying technical standards

Name	
ATEX (2014/34/EU)	ATEX – Intended use of equipment and protection systems in potentially explosive areas.
CSA 22.2 No. 60950-1	Information Technology Equipment – Safety – Part 1: General Requirements
ECE No. 10	E type approval for use in vehicles
EN 300 328	Electromagnetic compatibility and radio spectrum matters (ERM) - bandwidth transfer systems - data transmission equipment operating in 2.4 GHz ISM band and using spread spectrum modulation technology
EN 301 489-1	Electromagnetic compatibility for radio equipment and services
EN 301 489-17	Electromagnetic compatibility (EMC) for radio equipment and services - specific conditions for 2.4 GHz broadband transmission systems and 5 GHz high-performance RLAN equipment
EN 302 502	Broadband radio access networks (BRAN) – permanently installed broadband data transmission systems with 5.8 GHz band
EN 301 893	Broadband radio access networks (BRAN) – 5 GHz high performance Remote Local Area Network (RLAN)
EN 45545-1	Railway applications - Fire protection on railway vehicles - Part 1: General
EN 45545-2	Railway applications - Fire protection on railway vehicles - Part 2: Requirements for fire behavior of materials and components.
EN 50155	Railway applications – Electronic equipment used on rolling stock
EN 55032	Electromagnetic compatibility of multimedia equipment – Emission Requirements
EN 60529	Degrees of protection provided by housing – IP-Code
EN 60950-1	Information technology equipment – Safety – Part 1: General requirements
EN 60950-22	Installations of IT equipment – Security – Part 22: Outdoor equipments
EN 61000-6-2	Electromagnetic compatibility (EMC) – Part 6-2: Generic standards – Immunity for industrial environments
EN 61131-2	Programmable controllers – Part 2: Equipment requirements and tests
FCC 47 CFR Part 15	Code of Federal Regulations
FM3600	Approval Standard for Electrical Equipment for Use in Hazardous (Classified) Locations - General Requirements
FM3611	Approval Standard for Nonincendive Electrical Equipment for Use in Class I and Class II, Division 2, and Class III, Divisions 1 and 2, Hazardous (Classified) Locations
IEEE 802.1D	MAC Bridges (switching function)
IEEE 802.1Q	Virtual LANs (VLANs, MRP, Spanning Tree)
IEEE 802.1w	Rapid Reconfiguration
IEEE 802.11a/b/g/h/n	WLAN
IEEE 802.3	Ethernet
IEEE 802.3af	Power over Ethernet
UL 60950-1	Information technology equipment – Safety – Part 1: General requirements

Name	
IEC/EN 61850-3	Communication networks and systems for power utility automation - Part 3: General requirements.

The device has an approval based on a specific standard exclusively if the approval indicator appears on the device casing.
The device generally fulfills the technical standards named in their current versions.

A Further support

Technical questions

For technical questions, please contact any Hirschmann dealer in your area or Hirschmann directly.

You find the addresses of our partners on the Internet at <http://www.hirschmann.com>.

A list of local telephone numbers and email addresses for technical support directly from Hirschmann is available at <https://hirschmann-support.belden.com>.

This site also includes a free of charge knowledge base and a software download section.

Hirschmann Competence Center

The Hirschmann Competence Center is ahead of its competitors on three counts with its complete range of innovative services:

- ▶ Consulting incorporates comprehensive technical advice, from system evaluation through network planning to project planning.
- ▶ Training offers you an introduction to the basics, product briefing and user training with certification.
You find the training courses on technology and products currently available at <http://www.hicomcenter.com>.
- ▶ Support ranges from the first installation through the standby service to maintenance concepts.

With the Hirschmann Competence Center, you decided against making any compromises. Our client-customized package leaves you free to choose the service components you want to use.

Internet:

<http://www.hicomcenter.com>



HIRSCHMANN

A **BELDEN** BRAND