

1 PACKAGE CONTENTS

- User Manual
- Quick Start Guide
- Warranty Card
- Remote Control
- Battery x 2
- Screw (M5x12)x8
- Power Cord

2 INSTALLING THE STAND

Follow the illustrations below to complete the installation steps.

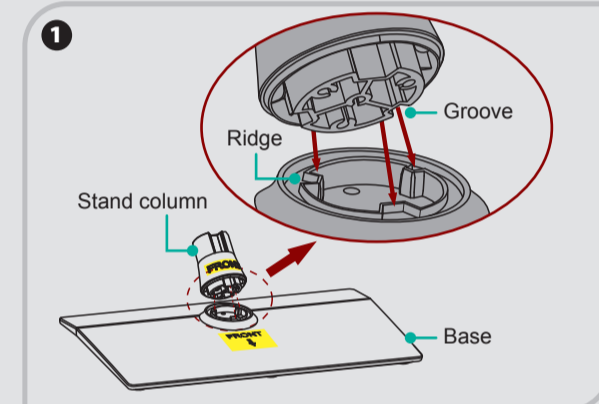

Align the front of the stand column with the front of the base, then insert the stand column into the base making sure that the groove in the stand column aligns with the ridge in the base.

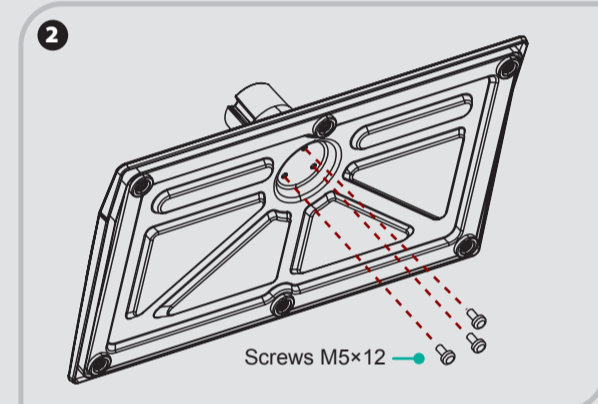

Secure the stand column to the base with 3 screws (M5x12).

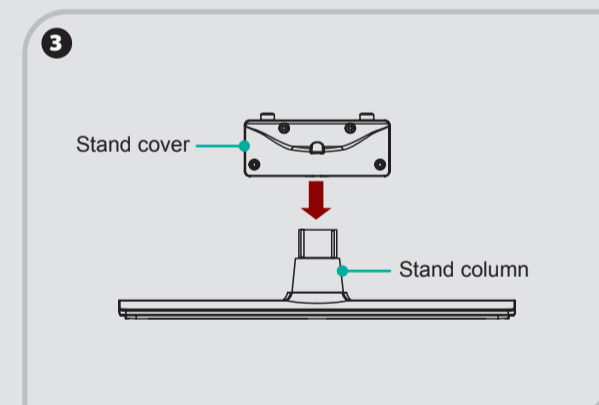

Align the stand cover with the stand column. Make sure that the bottom of the stand cover is flush against the top of the stand column.

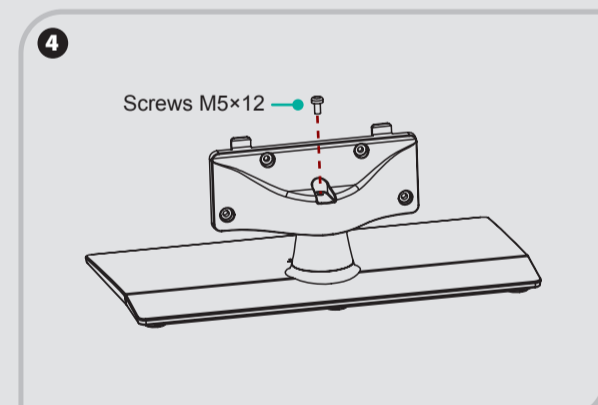

Secure the stand cover to the stand column with 1 screw (M5x12).

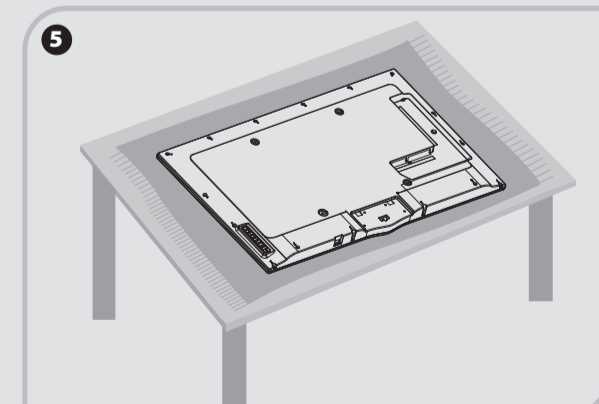

Carefully place your TV facedown on a soft, cushioned surface to prevent damage to the TV or scratching to the screen.

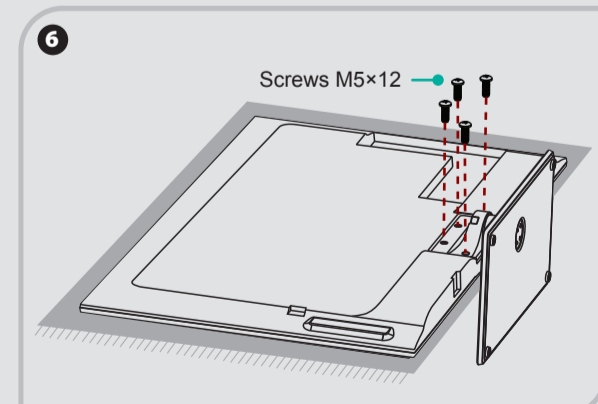

After pre-installing the stand, secure the stand to the TV with the 4 screws (M5x12).

NOTE Product image is only for reference, actual product may vary in appearance.

3 INSTALLING A WALL-MOUNT BRACKET

If you want to attach the TV to a wall-mount bracket (not provided), you should first remove the stand if it is pre-attached.

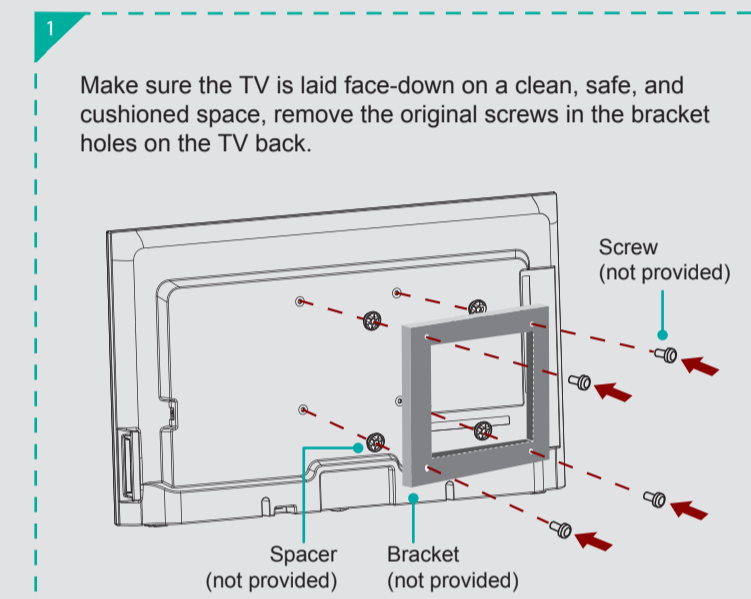

Place the spacers (not provided) in the corresponding bracket holes. Follow the instructions provided with the wall-mount bracket to attach the bracket on the TV.

WARNING

To prevent internal damage to the TV and ensure the TV is mounted securely, be sure to use fixing screws (not provided) which are 9.5 mm to 11.5 mm in length when measured from the attaching surface of the mounting hook.

Wall-Mount hole pattern VESA (mm)	200 × 200 (for 40")
	400 × 400 (for 48" 50")
Wall-Mount screw size (mm)	M6

Follow instructions provided with the Wall-Mount bracket.

- If you are not sure of your ability to do complete the installation, contact a professional installer or service technician for assistance. The manufacturer is not responsible for any damages or injuries that occur due to mishandling or incorrect assembly.

- The selected screws are 9.5 ~ 11.5 mm in length when measured from the attaching surface of the TV's rear cover. The diameter and length of the screws differ depending on the Wall-Mount Bracket model.

4 THE REMOTE CONTROL

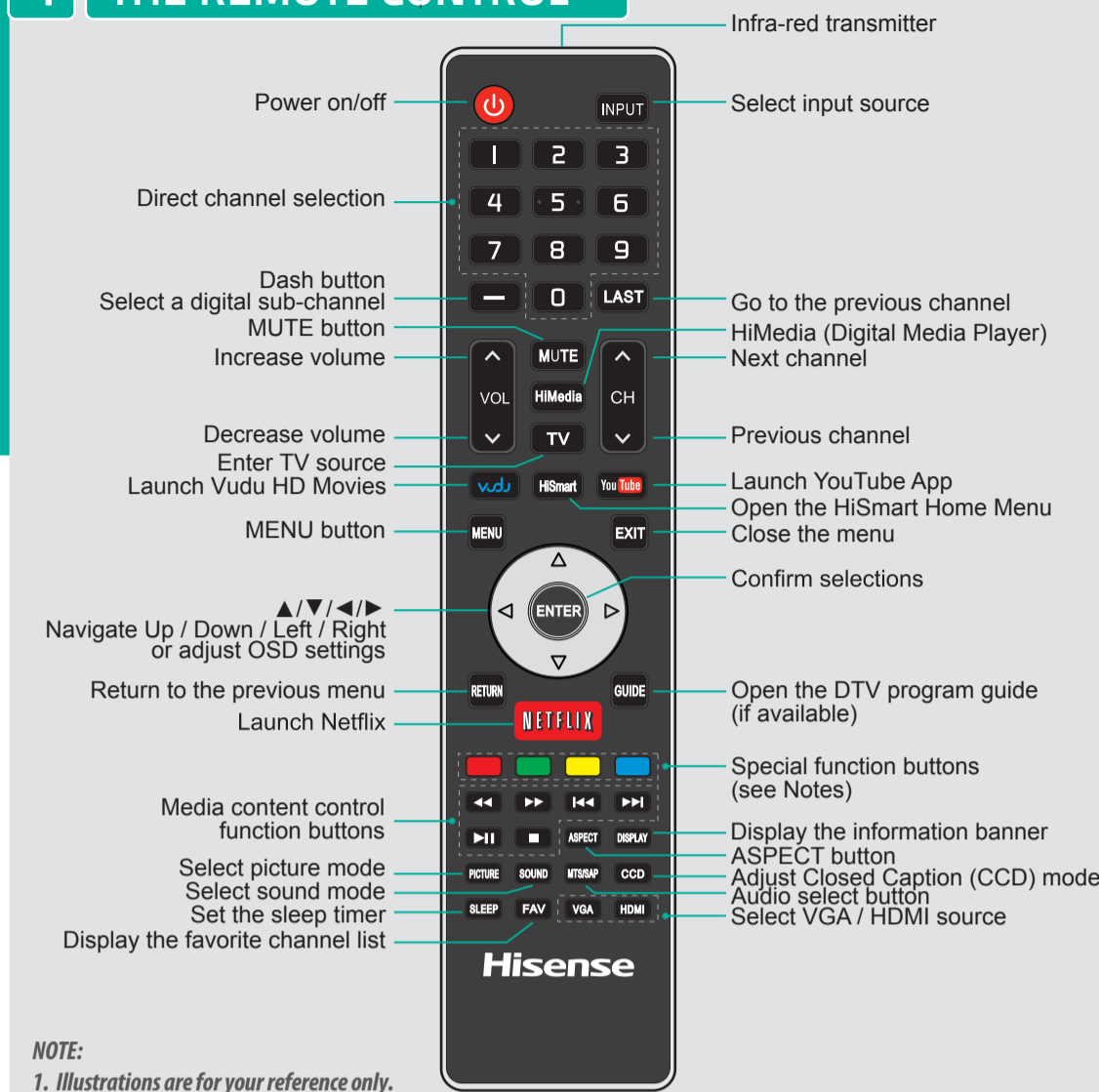

NOTE:
1. Illustrations are for your reference only.
2. Red/Green/Yellow/Cyan buttons are available when the same color buttons shown with explanations in the on-screen display. Follow the steps shown in the OSD.

5 MAKING CONNECTIONS

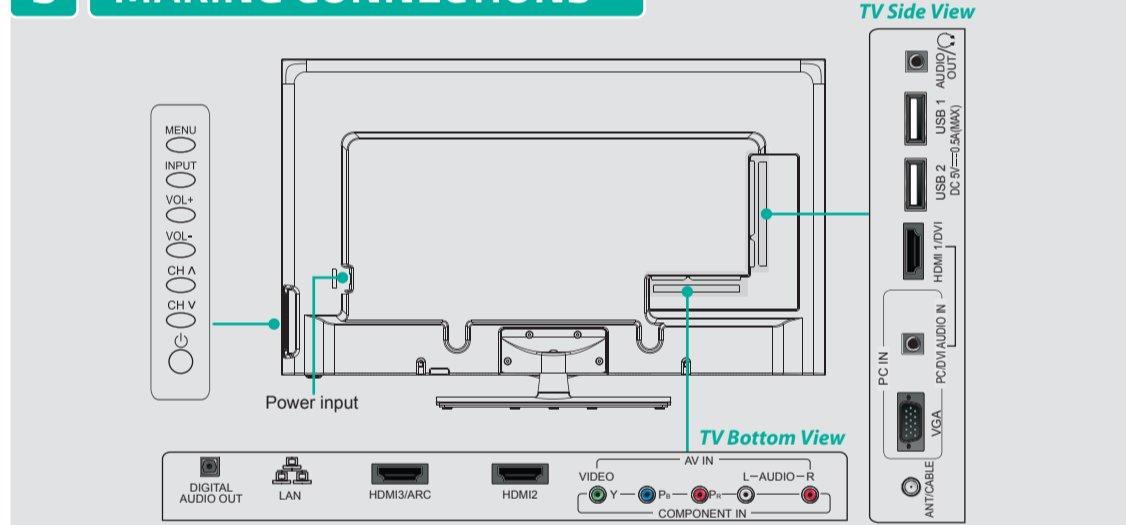

6 SPECIFICATIONS

Model Name	40H5	48H5	50H5G	
Dimension (W×H×D)	Without Stand	36.39 inches (924.3mm) 21.46 inches (545mm) 3.33 inches (84.5mm)	42.9 inches (1091mm) 25.1 inches (637mm) 3.3 inches (85mm)	44.4 inches (1129mm) 26.3 inches (667mm) 3.1 inches (79.9mm)
	With Stand	36.39 inches (924.3mm) 23.82 inches (605mm) 8.86 inches (225mm)	42.9 inches (1091mm) 27.7 inches (704mm) 11.1 inches (282mm)	44.4 inches (1129mm) 28.5 inches (725mm) 11.1 inches (282mm)
	Weight	Without Stand: 22.05 lbs (10 kg) With Stand: 25.35 lbs (11.5 kg)	Without Stand: 33.1 lbs (15 kg) With Stand: 39.7 lbs (18 kg)	Without Stand: 33.1 lbs (15 kg) With Stand: 39.7 lbs (18 kg)
Active Screen Size (Diagonal)	40 inches	47.6 inches	49.5 inches	
Screen resolution	1920 × 1080	1920 × 1080	1920 × 1080	
Audio power	7 W + 7 W	8 W + 8 W	10 W + 10 W	
Power consumption	Power consumption			
Power supply	120 V ~ 60 Hz			
Receiving systems	Analog	NTSC		
	Digital	ATSC / QAM		
Receiving channels	VHF: 2~13 UHF: 14~69 CATV: 1 ~ 125 Digital Terrestrial Broadcast (8VSB): 2 ~ 69 Digital cable (64/256 QAM): 1 ~ 135			
Tuner type	Frequency synthesized			
Environmental conditions	Temperature: 41°F ~ 95°F (5°C ~ 35°C)			
	Humidity: 20% ~ 80% RH Atmospheric pressure: 86 kPa ~ 106 kPa			
Component Input	480 I / 60 Hz, 480 P / 60 Hz, 720 P / 60 Hz, 1080 I / 60 Hz, 1080 P / 60 Hz			
VGA Input	VGA (640×480 / 60 Hz), SVGA (800×600 / 60 Hz), XGA (1024×768 / 60 Hz)			
HDMI Input	RGB / 60 Hz (640×480, 800×600, 1024×768)			
	YUV / 60 Hz (480 I, 480 P, 720 P, 1080 I, 1080 P)			

7 TV CONNECTORS

Check the jacks for position and type before making any connections. Loose connections can result in image or color problems. Make sure that all connections are tight and secure.

▶ **ANT** Connect an outdoor VHF/UHF antenna.

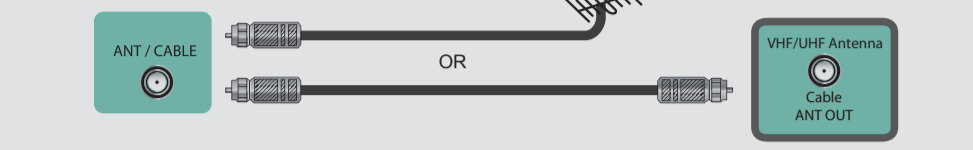

▶ **HDMI / COMP / AV** Connect an HDMI cable or Comp/AV Adapter from an external AV equipment.

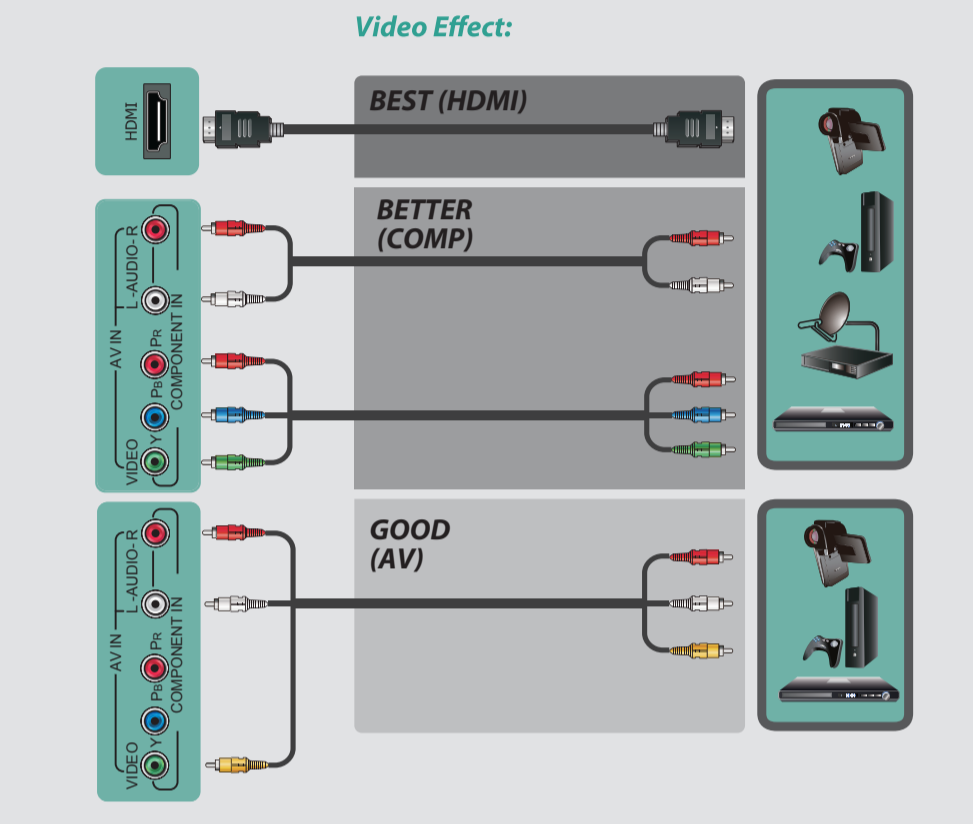

▶ **VGA & VGA AUDIO** Connect a VGA cable and an audio cable from the PC.



▶ **LAN** Connect an ethernet cable to access a network or the Internet. TV also features wireless connectivity.

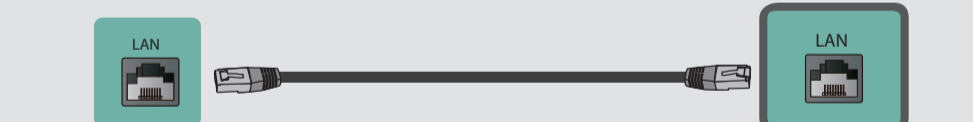

▶ **DIGITAL AUDIO OUT** Connect an optical cable from an external digital audio system.

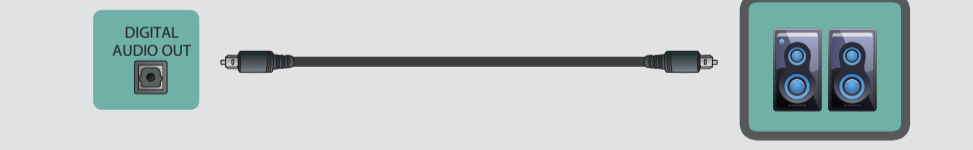

▶ **HEADPHONE** Connect Headphone for audio out of the TV.



▶ **USB** Connect a USB device for browsing photos, music and movies.

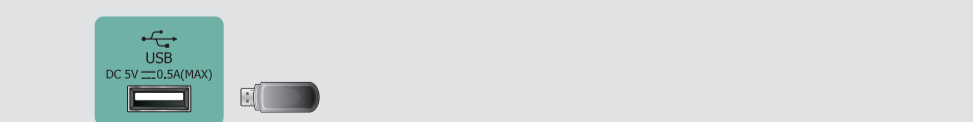

8 TURNING THE TV ON FOR THE FIRST TIME

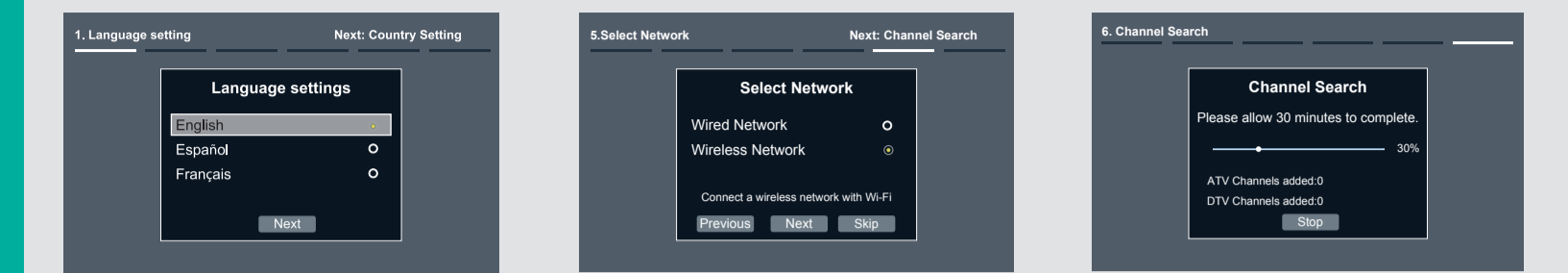

MENU	OPERATIONS
Language setting	<ul style="list-style-type: none"> • Please press [ENTER] to start the wizard, then press [▲/▼] button to select your language: English, Spanish or French, select [Next] to confirm enter the Welcome screen. • In the Welcome screen introduced the available input devices and interfaces.
Country setting	<ul style="list-style-type: none"> • Please press [▲/▼] button to select the country where you will operate the TV.
Time zone setting	<ul style="list-style-type: none"> • Select the local time zone according to your region. • Daylight Saving: Set the Daylight Saving time for your area.
Use Mode	<ul style="list-style-type: none"> • Select your Mode Setting: Home Mode or Retail Mode. • If you select Retail Mode, a message appears "Are you sure to change to retail mode?" Select "OK" to continue, or select "No" to change your selection. • Home Mode is the recommended setting which offers full functionality of the television. If you selected Retail Mode, Energy Saving is not realized.
Select Network	<ul style="list-style-type: none"> • The Select Network : Connect your TV to access the network. • When the Network Setting menu opens, Hisense Service Terms and Conditions will appear. Press [◀▶] to scroll through the pages. Please read it carefully. If you want to access the internet, press the [Agree] button to set your TV's network connections. Otherwise, press the [Disagree] button to enter the Channel search menu. • You can setup the network configuration in this menu. For more information, please refer to the section titled "Network Connection" and "Network Setup" in the user manual.
Channel Search	<ul style="list-style-type: none"> • Press [▲/▼] to select your Tuner Mode: Antenna or Cable, press [ENTER] button to confirm. • Press [◀▶] to set the Channel Installation: Scan or Skip Scan, press [ENTER] button to confirm. If you select "Scan", your TV automatically starts Channel Installation available in your viewing area; If you select "Skip Scan", your TV does not scan for channels; Depending on the reception condition, it may take up to 30 minutes or more to complete memorizing channels. Please allow the process to complete without interruption. • After scan, you will enter the complete interface. It will display all informations that you set just now and then you can press "Go" to exit the wizard.

Note:
If you are using a cable or satellite box and you have connected it to the TV using a Coaxial cable, you should select the cable option. Be sure the cable or satellite box is turned on before starting the channel scan. If you use a cable or satellite box connected to AV, Component or HDMI, you don't need a scan for channels.

9 TROUBLESHOOTING TIPS

When there is something wrong with your TV, you can try turning off the TV and restarting it. You can also refer to the following chart for problem and solution tips. If the problem cannot be resolved, please contact Hisense for additional assistance.

SYMPTOMS	POSSIBLE SOLUTIONS
No sound or picture	<ul style="list-style-type: none"> • Confirm power cord is plugged into the AC outlet and the AC outlet is getting electricity. • Attempt to power on unit using the power button on both the TV and the Remote.
Picture is normal, but no sound	<ul style="list-style-type: none"> • Check the volume settings. • Check if Mute mode is set "on".
I have connected an external source to my TV and I get no picture and/or sound.	<ul style="list-style-type: none"> • Check for the correct output connection on the external source and for the correct input connection on the TV. • Make sure you have made the correct selection for the input mode for the incoming signal.
Network connection fail.	<ul style="list-style-type: none"> • Check network physical connection, make sure connection is correct. • Enter "Menu", "Network", "Configuration", make sure configuration is correct according to your network service provider. • Enter "Menu", "Network", "Configuration", "Connection Test" to make sure that network connection test is successful.
Connect Vudu/Netflix fail.	<ul style="list-style-type: none"> • Check network physical connection, make sure connection is correct. • Enter "Menu", "Network", "Configuration", make sure configuration is correct according to your network service provider. • Enter "Menu", "Network", "Applications", "VUDU/Netflix", "Deactivation" to reset "VUDU/Netflix" account.
How do I get easy IPTV to work on my TV?	<ul style="list-style-type: none"> • You need a broadband (high speed) Internet service with a speed of no less than 1.5 Mbps. • Connect the TV to the internet through your router by an Ethernet Cable or wireless. If connection fails, check with your internet service provider or router manufacturer to determine if there is a firewall, content filter, or proxy settings that may block the TV from accessing the internet. • Before calling for service, check the following information for possible solutions to problems you may experience. If none of these solutions work, turn off the TV, then turn it on again. • Caution: Do not try to repair the TV yourself. Refer all servicing to qualified repair personnel.