



## **User's Manual for Bluetooth Profile Unit**

**Model: HA-1234**

[Rev. R01]

[October 12, 2004]

Hitachi-Omron Terminal Solutions, Corp.

**Read this manual thoroughly and keep it**

- Be sure to read safety descriptions in the manual and understand them before using this product.
- Keep the manual at hand for your quick reference.

---

## Introduction

---

Thank you for purchasing the Bluetooth Profile Unit (HA-1234).

The unit enables wireless data communication using Bluetooth and has the following features:

- Bluetooth Serial Port Profile (SPP) is built in.
- Bluetooth Class 2 transmission output power is supported, enabling wireless communication in the distance range of 10m with clear view.
- Unique command interface enables command control and data communication using a single serial port.
- Bluetooth-standard function for encrypted communication is supported.
- Bluetooth-standard low power state function (Sniff mode) is supported.

### ■ Notices

- No part of this manual may be reproduced without permission.
- Contents of this manual may be subject to change without prior notice.
- Applications described in this manual show typical ones for use with our products. This manual never guarantees implementation of industrial property right and other rights or grants license. And also, any problems, related to industrial property right and others, resulting from using the product, arise with a third party, please note that we take no responsibility for them.
- Please note that we take no responsibility for effect led by the operation result regardless of the preceding clause.
- The unit is available for use in limited areas. If you are thinking of using it overseas, contact us.
- If you build the unit into another device and then use it in Japan, it is recommended that words such as “Contains wireless equipment with Technical Regulations Conformity Certification Stipulated in the Radio law ” be labeled on the relevant device.
- If you build the unit into another device and then use it in North America, be sure to label the words “Contains FCC ID: SOE-HA-1234” on the relevant device.

### ■ Trademark notice

Bluetooth is a trademark for Bluetooth SIG. Inc., USA.

---

## Important

---

### Warning: abnormal heat, smoke and unusual sound/smell

If something abnormal occurs during use, stop use the unit, turn the power off and disconnect the power cable immediately. Failure to do so may result in electric shock or fire.

### Caution: Interference

Installing the unit adjacent to other electronics equipment may have harmful effects on each other. If equipment including TV and radio are existed near the unit, noises may be produced. In such case, do as described below.

- Separate the unit from equipment including TV and radio as far as possible.
- Reorient these equipment antennas.

---

## Precautions for Handling

---

- If the unit is used with systems, which require a high level of reliability and safety in their functions and performance, such as operation equipment (e.g. aircraft, train, vehicle), disaster/crime-prevention equipment and safety devices produced by various manufactures, please take the whole safety design into consideration by implementing fail-safe design or redundant design in order to maintain the reliability and safety of the whole of these systems/equipment.
- The unit is not intended to use with equipment, which requires extremely high level of reliability and safety, such as aerospace equipment, mainline-communication equipment, nuclear energy control equipment or life-support medical equipment. Never use the unit with these equipment.
- The unit is a communication device using radio waves in conformance with Bluetooth specifications. When the unit is used in places where radio waves are apt to spread out (e.g. outdoors where no obstacles exist) or where radio waves are not be transmitted smoothly indoors separated by walls, the transmittable distance may be changed, depending on the wave conditions. Please note that even during normal communication they may be interrupted, depending on the wave conditions
- The unit uses radio waves. Thus, there is possibility of getting wiretapped by third parties. If you require the communication to be concealed, use concealment process such as encryption function of the unit.
- Please note that we take no responsibility for pure economic loss resulting from losing a chance of communication or others due to wrong operation, malfunction or external factors including power failure.
- Installing the unit near microwave, TV, radio or speaker may produce harmful effects of noises and others.
- We take no responsibility for damages resulting from cases such as where the unit is used by deviating from its use conditions or precautions described in this manual.

---

## Precautions for Mounting / Installation

---

- The wireless unit complies with Radio Law. Never disassemble or modify it.

---

## Precautions for Operation

---

- Be sure to use the unit with rated voltage, temperature and humidity. Failure to do so may causes malfunction of the unit, and also its performance will not be guaranteed.



## **Federal Communication Commission Interference Statement**

---

This equipment has been tested and found to comply with the limits for a Class B digital device, pursuant to Part 15 of the FCC Rules. These limits are designed to provide reasonable protection against harmful interference in a residential installation. This equipment generates, uses and can radiate radio frequency energy and, if not installed and used in accordance with the instructions, may cause harmful interference to radio communications. However, there is no guarantee that interference will not occur in a particular installation. If this equipment does cause harmful interference to radio or television reception, which can be determined by turning the equipment off and on, the user is encouraged to try to correct the interference by one of the following measures:

- Reorient or relocate the receiving antenna.
- Increase the separation between the equipment and receiver.
- Connect the equipment into an outlet on a circuit different from that to which the receiver is connected.
- Consult the dealer or an experienced radio/TV technician for help.

FCC Caution: To assure continued compliance, (example - use only shielded interface cables when connecting to computer or peripheral devices) any changes or modifications not expressly approved by the party responsible for compliance could void the user's authority to operate this equipment.

This device complies with Part 15 of the FCC Rules. Operation is subject to the following two conditions: (1) This device may not cause harmful interference, and (2) this device must accept any interference received, including interference that may cause undesired operation.

---

## **IMPORTANT NOTE: FCC Radiation Exposure Statement:**

---

This equipment complies with FCC RF radiation exposure limits set forth for an uncontrolled environment. To maintain compliance with FCC RF exposure compliance requirements, please avoid direct contact to the transmitting antenna during transmitting.

---

**IMPORTANT NOTE:****Industry Canada / Radio Equipment**

---

Certification number for radio field will be given by Industry Canada if the product meets the demand of IC technical specification.

Operation of this device is subjected to the following two conditions :  
(1) this device may not cause interference, and (2) this device must accept any interference, including interference that may cause undesired operation of the device.

The installer of this radio equipment must be ensured that the antenna does not emit RF field limit, which is defined by Health.

Canada for general public. For more details, see Safety Code 6, from Health Canada's website [www.hc-sc.gc.ca/rpb](http://www.hc-sc.gc.ca/rpb)

## Scope

This manual describes how to operate HA-1234/Bluetooth Profile Unit (BPU).

## 2. Unit Specifications

### 2.1 Part Names

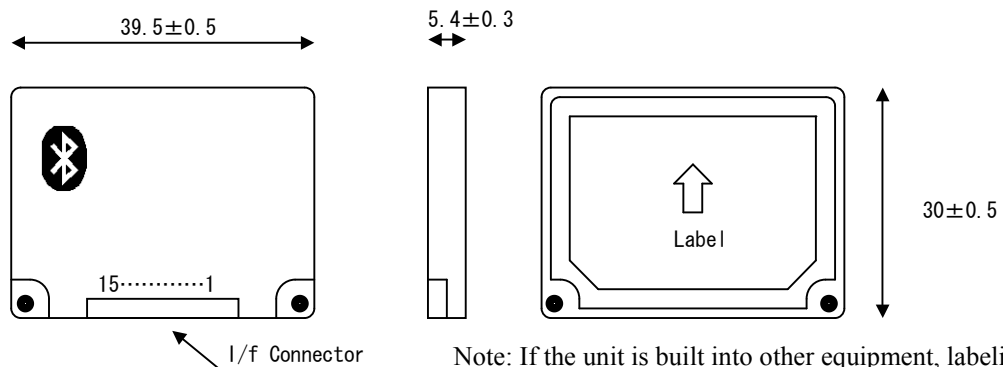

### 2.2 Unit Specifications

No.	Item	Specifications
1	Bluetooth Specification	Bluetooth Specification v1.2
2	Profile Support	Generic Access Profile
		Service Discovery Application Profile
		Serial Port Profile
3	BD Address	IEEE std802 48bit LAN MAC Address
4	Bluetooth Device Name	Desired One Settable (Default: "Bluetooth Profile Unit" ASCII)
5	Bluetooth Device Class	Desired One Settable (Default: "000000" HEX)
6	Link Key	7 Key Storable (Store in ROM.)
7	Discoverability Mode	"Non-discoverable Mode", "General discoverable Mode" Supported "Limited discoverable Mode" Unsupported
8	Pairing Mode	Supported Selectable between "Non-pairable Mode"/"Pairable Mode"
9	Bluetooth Pass Key (PIN)	Desired One Settable (Default: "1111" ASCII)
10	Security Mode	Selectable between "Security Mode 1" and "Security Mode 3"
11	Inquiry	"General Inquiry" Supported "Limited Inquiry" Unsupported
12	Bluetooth Name Discovery	Supported
13	Encryption	Supported
14	Low Power State	"Sniff Mode" Supported
15	RS-232C Communication Specifications (PC – BPU) (Note 1)	Baudrate: 9600bps (Note2), Data Length: 8bits Stop-bit length: 1bit, Parity: None Flow Control: RTS/CTS Flow
16	Bluetooth Transmission Output	Class 2
17	Bluetooth Communication Distance	Aprox. 10m
18	Power Source	DC : +3.3 -0.1/+0.2 V
19	Dimensions	(39.5) x (30) x (5.4)mm
20	Weight	Approx. 8g

(Note 1): The baudrate, data bit length, stop bit length and parity are variable. The values described in the table are default ones.

(Note 2): The transmission rate is not effective speed.

## (2) Power Specifications

No.	Item	Specifications
1	Supply Voltage	DC: +3.3 -0.1/+0.2 V
2	Current Consumption (TYP)	80 - 100mA
3	Protective Function	non

## (3) DC Characteristics of Signal

No.	Mode	symbol	min	max	unit	Remarks
1	Input HIGH level	V <sub>IH</sub>	2.3	VCC+0.2	V	VCC=3.3V
2	Input LOW level	V <sub>IL</sub>	0	VCCx0.15	V	VCC=3.3V
3	Output HIGH level	V <sub>OH</sub>	1.8		V	VCC=3.3V, I <sub>OH</sub> =-2mA
4	Output LOW level	V <sub>OL</sub>		0.65	V	VCC=3.3V, I <sub>OL</sub> =2mA
5	Supply current	I <sub>cc</sub>		120	mA	

## (4) Connector Pin Specifications

[Connector 1: Connector for Cable Connection (SM15B-SRSS-G-TB/Manufacturer:JST)]

No.	Signal Name	I/O	Remarks
1	DCD	O	UART SIGNAL
2	RXD	O	UART SIGNAL
3	TxD	I	UART SIGNAL
4	DTR	I	UART SIGNAL
5	GND	-	
6	DSR	O	UART SIGNAL
7	RTS	I	UART SIGNAL
8	CTS	O	UART SIGNAL
9	NC	-	Unconnected (Reserved) – Never connect anything.
10	VCC	-	+3.3 -0.1/+0.2V
11	NC	-	Unconnected (Reserved) – Never connect anything.
12	NC	-	Unconnected (Reserved) – Never connect anything.
13	GND	-	
14	LED1	O	Status LED Signal
15	LED2	O	Status LED Signal

## (5) Environment Specifications

Item	Environment Conditions
Operable: Temperature / Humidity	-20°C - +60°C / 20% - 80% (No Condensation)
Storage: Temperature / Humidity	-30°C - +75°C / 20% - 80% (No Condensation)

## 2.3 LED Lighting Specifications

BPU Status	LED		Status
	Red	Green	
0	○	X	H/W Initial Setting, H/W Checking
	○	○	F/W Start-UP Process
1	X	X	Waiting for F/W Initialization
2	X or □ Note	□	On Standby
3	☆	☆	Waiting for INQUIRY Completion
4	☆	☆	Waiting for REMOTENAME Completion
5	△	○	Waiting for Automatic Connection
6	X or △ Note	△	On Standby (Security Mode 1)
7	X or ▽ Note	▽	On Standby (Security Mode 3)
8	X	☆	Waiting for Connection Completion
9	X or ○ Note	○	Connecting (Active Mode)
	X	X	Connecting (Sniff Mode)
A	X	X	Waiting for Disconnection
B	□	X	Malfunction
C	○	X	Hardware Failure

○: ON, ☆: Blinking (every 0.25sec), △: Blinking (every 0.5sec), ▽Blinking (ON: every 0.25sec, OFF: every 0.75sec.)

◎: Blinking (ON: every 0.75sec, OFF: every 0.25sec.), □: Blinking (every 1sec), X: OFF

Note: Red/Green LED comes on at the same time in Command Mode (DTR: OFF). (The color of the LED looks orange.)

## 2.4 Connection Pattern

Devices, which the BPU is expected to communicate with, include the BPU connected to a serial device and Bluetooth dongle device connected to a cellphone.

The BPU supports Point to Point connection and Multi-Point (Piconet) connection.

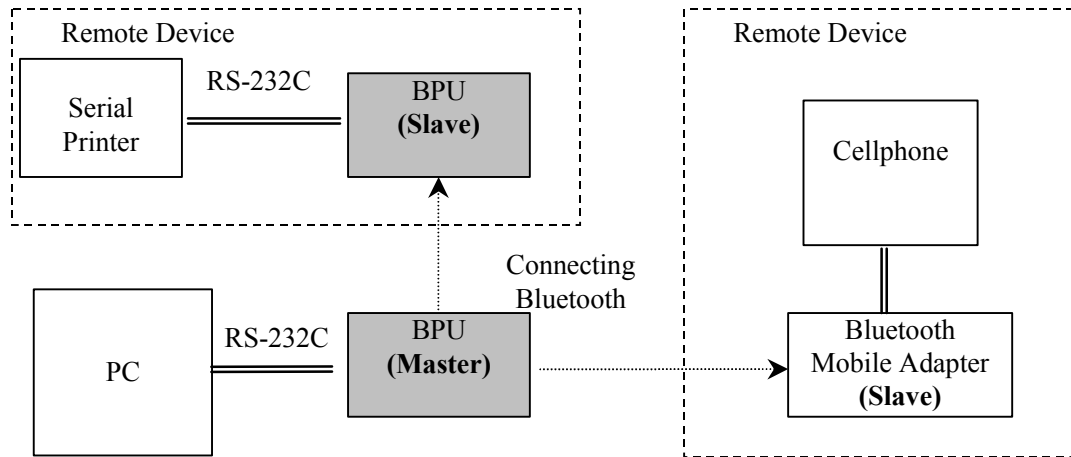

[ Example ]

## 2.5 Operation Mode

The BPU has two modes, “Command Mode” and “Communication Mode”, which are selected by DTR signal input from PC.

### (1) Command Mode

The mode accepts various kinds of setting and control for Bluetooth.

The mode enables connection to a remote device.

DTR signal at PC: OFF (signal level “0”) makes the BPU enter the mode.

### (2) Communication Mode

The mode enables serial connection by Bluetooth, and also data transmission to/receive from a remote device.

DTR signal at PC: ON (signal level “1”) makes the BPU enter the mode.



### 3. Functions

#### 3.1 Command Mode Functions

The mode is used with DTR signals from PC: OFF. All data transmitted from PC under the condition are interpreted as a command.

The BPU responds to a command and may give multiple responses to a single command.

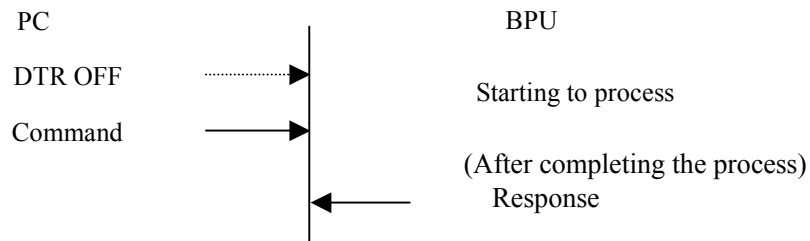

No.	Item	Command	Description
1	Inquiry	INQUIRY	Makes inquiry and gets peripheral device information.
2	Get Remote Device Name	REMOTENAME	Gets Bluetooth device name of a remote device.
3	Set Local Device	LOCALDEVICE	Sets and gets Bluetooth device name and others of BPU.
4	Set Bluetooth Pass Key	PASSKEY	Sets and gets Bluetooth pass key for use in Authentication.
5	Set Bonding Information	BOND	Sets and gets bonding information for use in Authentication.
6	Connect	CONNECT	Connects to a remote device.
7	Wait for Connection	WAIT	Waits for connection from a remote device.
8	Disconnect	DISCONNECT	Disconnects from a remote device.
9	Set Communication	SETBAUDRATE	Sets PC-BPU communication.
10	Check Version	VERSION	Indicates BPU firmware version.
11	Set Echo	ECHO	Sets whether response subsequent to completed connection to Bluetooth is given or not.
12	Automatic Connection	AUTO	Sets automatic connection to a remote device.
13	Encryption	ENCRYPTION	Sets encrypted communication.
14	Local Status	LOCALSTATUS	Gets PC-BPU signal status and BPU status.
15	Remote Status	REMOTESTATUS	Gets signal/connection status of a remote device.
16	Set Park Mode	PARK	Sets low power consumption PARK Mode.
17	Get Error Information	ERROR	Gets error information occurred in BPU.
18	Reset	RESET	Resets BPU firmware.
19	Clear Command Buffer	EOT (0x04)	Clears command buffer in BPU.
20	Set Expanded Function	EXFUNC	Sets expanded functions.
21	Set Connection Time-out	TIMEOUT	Sets time-out period for CONNECT command.

Table 1: Command List

### 3.2 Communication Mode Function

DTR signal from PC: ON makes the BPU enter Communication Mode.  
All data transmitted from PC in the mode are interpreted as transmit data to a remote device. And also, all data the BPU receives from a remote device are transmitted to PC.  
Data transmitted to the BPU, prior to connection to a remote device, with DTR ON are not sent to the remote device as the data are cleared at the time of the connection.

