

EXHIBIT 5

Instruction Manual

HITACHI

DIGITAL MPEG CAMERA

MP-EG10W

INSTRUCTION MANUAL

Hitachi Home Electronics (America), Inc.
For information concerning repairs, operation or
technical assistance, please contact the Service
Department of your nearest Regional Office.

Southern Regional Office
675 Old Peachtree Road Suwanee, GA 30174
Tel. 404-279-5600

Western Regional Office
905 E. South Street Anaheim CA 92805
Tel. 714-517-6000

Hitachi Sales Corporation of Hawaii, Inc.
3219 Koapaka Street, Honolulu, Hawaii 96819
Tel. 808-836-3621

Hitachi (HSC) Canada Inc.
3300 Trans Canada Highway, Pointe Claire,
Quebec, H9R 1B1, CANADA

Warning : This device complies with Part 15 of the FCC Rules. Operation is subject to the following two conditions: (1) This device may not cause harmful interference, and (2) this device must accept any interference received, including interference that may cause undesired operation.

Note: This equipment has been tested and found to comply with the limits for a Class B digital device, pursuant to Part 15 of the FCC Rules. These limits are designed to provide reasonable protection against harmful interference in a residential installation. This equipment generates, uses, and can radiate radio frequency energy and, if not installed and used in accordance with the instructions, may cause harmful interference to radio communications. However, there is no guarantee that interference will not occur in a particular installation. If this equipment does cause harmful interference to radio or television reception, which can be determined by turning the equipment off and on, the user is encouraged to try to correct by one or more of the following measures:

Reorient or relocate the receiving antenna.

Increase the separation between the equipment and receiver.

Connect the equipment into an outlet on a circuit different from that to which the receiver is connected.

Consult the dealer or an experienced radio/TV technician for help.

Caution to the user : Changes or modifications not expressly approved by the manufacture could void the user's authority to operate the equipment.

Microsoft® , Windows® and PowerPoint® are registered trademarks of Microsoft Corporation.
Intel® and Pentium® are registered trademarks of Intel Corporation.
SoftPEG is a registered trademarks of CompCore Multimedia Inc.
IBM®, IBM PC/AT® and PowerPC™ are registered trademark of International Business Machines Corporation.
SoundBlaster is a registered trademark of Creative Technology Ltd.
Macintosh™ and Mac™OS are registered trademarks of Apple Computer, Inc.
Other company names and product names listed are trademarks or brand names belonging to each company.

11A An appliance and cart combination should be moved with care. Quick stops, excessive force, and uneven surfaces may cause the appliance and cart combination to overturn.



12 Outdoor Antenna Grounding - If an outside antenna or cable system is connected to the video product, be sure the antenna or cable system is grounded so as to provide some protection against voltage surges and built-up static charges. Section 810 of the National Electrical Code, ANSI/NFPA No. 70, provides information with respect to proper grounding of the mast and supporting structure, grounding of the lead-in wire to an antenna discharge unit, size of grounding conductors, location of antenna-discharge unit, connection to grounding electrodes, and requirements for the grounding electrode. See example below.

EXAMPLE OF ANTENNA GROUNDING

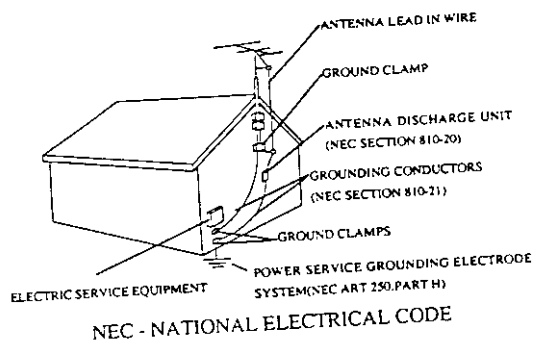

13 Power Lines — An outside antenna system should not be located in the vicinity of overhead power lines or other electric light or power circuits, or where it can fall into such power lines or circuits. When installing an outside antenna system, extreme care should be taken to keep from touching or approaching such power lines or circuits as contact with them might be fatal. Installing an outdoor antenna can be hazardous and should be left to a professional antenna installer.

USE

14 Cleaning — Unplug this video product from the wall outlet before cleaning. Do not use liquid cleaners or aerosol cleaners. Use a damp cloth for cleaning.

15 Object and Liquid Entry — Never push objects of any kind into this video product through openings as they may touch dangerous voltage points or short-out parts that could result in a fire or electric shock. Never spill liquid of any kind on the video product.

16 Lightning — For added protection for this video product during a lightning storm, or when it is left unattended and unused for long periods of time, unplug it from the wall outlet and disconnect the antenna or cable-system. This will prevent damage to the video product due to lightning and power-line surges.

SERVICE

17 Servicing — Do not attempt to service this video product yourself as opening or removing covers may expose you to dangerous voltage or other hazards. Refer all servicing to qualified service personnel.

18 Conditions Requiring Service — Unplug this video product from the wall outlet and refer servicing to qualified service personnel under the following conditions.

- a. When the power — supply cord or plug is damaged.
- b. If liquid has been spilled, or objects have fallen into the video product.
- c. If the video product has been exposed to rain or water.
- d. If the video product does not operate normally by following the operating instructions. Adjust only those controls that are covered by the operating instructions. Improper adjustment of other controls may result in damage and will often require extensive work by a qualified technician to restore the video product to its normal operation.
- e. If the video product has been dropped or the cabinet has been damaged.
- f. When the video product exhibits a distinct change in performance — this indicates a need for service!

19 Replacement Parts — When replacement parts are required, have the service technician verify that the replacements he uses have the same safety characteristics as the original parts. Use of replacements specified by the video product manufacturer can prevent fire, electric shock or other hazards.

20 Safety Check — Upon completion of any service or repairs to this video product, ask the service technician to perform safety checks recommended by the manufacturer to determine that the video product is in safe operating condition.

21 Heat — The product should be situated away from heat sources such as radiators, heat registers, stoves, or other products (including amplifiers) that produce heat.

Read This First

To guide you, we've included following eight chapters.

- Chapter 1, "Introduction", gives you how to use your MP-EG10W efficiently, and explains the overview of your MP-EG10W.
- Chapter 2, "Set-up", explains how to set up your MP-EG10W for recording.
- Chapter 3, "Recording", explains how to record moving pictures, still pictures, etc. Read thoroughly before starting to record.
- Chapter 4, "Playback", explains how to play back recorded pictures and sound, and search for files you want to play back.
- Chapter 5, "Operating files", explains how to use Media Navigation for arranging recorded files, editing folder for auto play, etc.
- Chapter 6, "Using the MP-EG10W with Other Equipment", explains how to use the MP-EG10W with a TV or a personal computer.
- Chapter 7, "Menu Settings", explains how to operate the on-screen menu for desired settings.
- Chapter 8, "Subsidiary Information", shows various information, including what to do when you are in trouble. Refer to each item as needed.

We want this manual to be as helpful as possible, so it includes two easy ways to find the information you need:

- A quick index for the information you use most often (this page).
- A detailed table of contents directing you to specific information quickly (page 9).





Get to know your MP-EG10W by using this manual, and get to know Hitachi. We appreciate your business.

Quick Index

Charging Battery Pack	20
Recording Moving Pictures	31
Playing Back the File Just Recorded	40
Connecting to TV and Viewing Playback Pictures	68
Connecting to Your Personal Computer	70

- The MPEG1 standard is used for the MP-EG10W to handle moving pictures. The playback picture will be slightly rougher, but this does not indicate a fault.
- The MP-EG10W mechanism is configured so the PC card cannot be removed when hot. Wait until it cools down to remove.
- Do not set the CAM/OFF/PLAY switch to OFF when the ACCESS indicator is flashing.
- Be sure to set the CAM/OFF/PLAY switch to OFF once before switching it between CAM (REC) and PLAY.

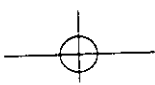
Registration and more information: <http://www.mpegcam.net>



Before Using

Compensation for recorded contents:

If the unit or PC card becomes faulty during use and no recording is possible on PC card or playback from it, we will not be responsible for compensation for your lost recordings.

Make a trial recording before recording important events:

If recorded data is erased because the unit malfunctions, the data cannot be restored.

Copyrights:

You cannot use recordings of copyrighted materials for purposes other than for your private enjoyment, without permission of their rightful owner.

Be careful of Moisture Condensation

Condensation:

When a heater is used in your room in a cold season, windowpanes will be frosted. This is because vapor in air indoors is cooled rapidly and moisture is formed. This is referred to as condensation.

Condensation occurs:

When you move unit from a cold place to a warm place abruptly, such as when you enter a lodge from a ski slope; When you place the unit in a room in which heating has just begun or in a place where cool air strikes unit directly; When you move the unit outside from a cooled room or vehicle in a hot season.

When condensation occurs:

Leave unit in a place as dry as possible for about one hour before using it. When moisture condenses on the lens, a clear picture cannot be recorded. Start recording after condensation of the lens has been removed.

CONTENTS TABLE

For Your Safety	
IMPORTANT SAFEGUARDS	2
IMPORTANT SAFETY INSTRUCTIONS FOR AC ADAPTER/CHARGER	4
Read This First	5
Cautions When Using	6
Before Using	7
Checking the Provided Accessories	8
CONTENTS TABLE	9
Chapter 1 Introduction	11
Features	12
Operating Files	14
PC Card	15
Names of Each Part	16
Viewing the On-Screen Display	17
Chapter 2 Set-up	19
Charging Battery Pack	20
Loading the Battery Pack	21
Using Power Supply from AC Outlet	22
Loading the PC Card	23
Setting the Date and Time	24
Inserting Battery into the Remote Control	27
Tips for Skillful Use of the MP-EG10W	28
Chapter 3 Recording	29
Rotating the Camera Block and Attaching the Sunshade	30
Recording Moving Pictures	31
Recording Still Pictures	33
Recording Still Pictures at Intervals	34
Recording Consecutive Still Pictures	35
Recording a Still Picture with Audio	36
Recording Image of Your Portrait Using the Remote Control	37
Chapter 4 Playback	39
 Playing Back the File Just Recorded	40
 Locating Files to be Played by Skipping Start Pictures	41
 Order of Files to be Played	42
 Playback Using the Remote Control	43

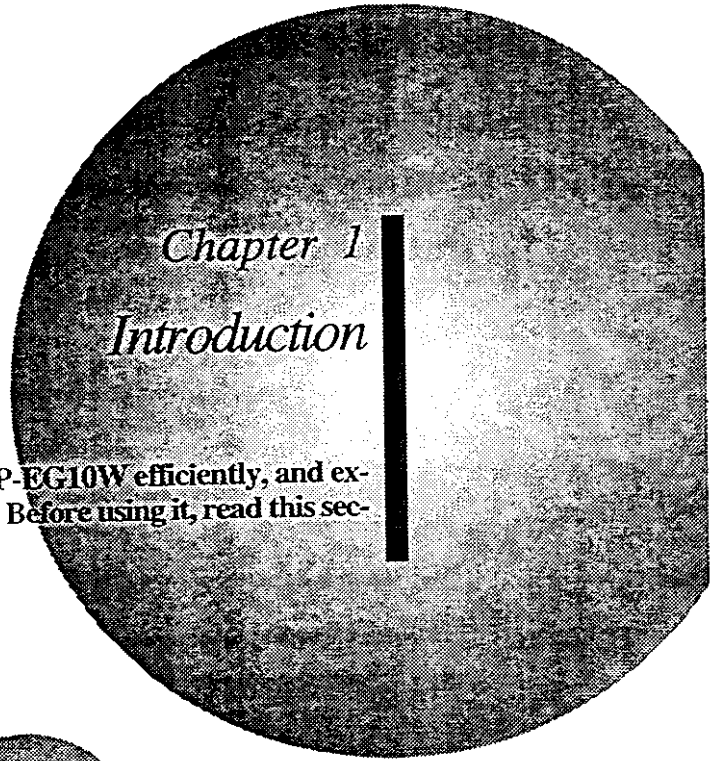
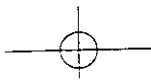

This section gives you how to use your MP-EG10W efficiently, and explains the overview of your MP-EG10W. Before using it, read this section thoroughly.

Features	12
Operating Files	14
PC Card	15
Names of Each Part	16
Viewing the On-Screen Display	17

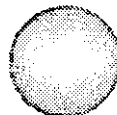
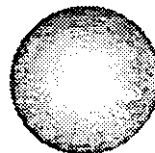
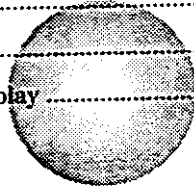
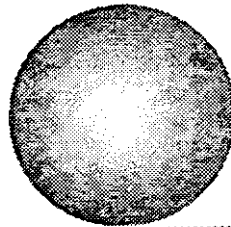

A Variety of Uses

Presentation by using application software:

Microsoft® Office 97 (PowePoint® 97, Word 97, Excel 97), Microsoft® Access etc.

For creating multimedia contents and materials for Internet homepage or Intranet Lan:

Because being stored in file, it is easy to send files in a personal computer. This is most suitable for creating multimedia contents and materials for Internet home page. You can use the stored video file in a variety of joyful ways such as wallpaper for your computer.

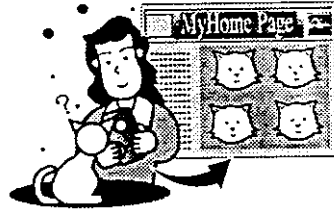

Playback and edit the files on your personal computer:

Transfer files to your computer, and you can view them with computer software and edit the files with the bundle software.



Printing:

You can print files with a generally available video printer, or retrieve transferred files on your computer and print them with the computer printer.



For gathering materials:

You can choose the recording mode to suit the material, such as recording moving subjects with a motion picture mode adding a narrative with recording still picture when recording commodities, etc.



For presentation:

You can use the file management function, Media Navigation, to easily arrange and edit files containing recording files by grouping, sorting, etc. After arranging the files, connect the MP-EG10W to a TV and execute auto play for presentation.

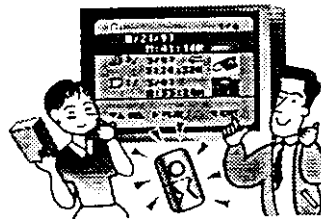

PC Card

What is a PC card?

The MP-EG10W stores video and audio data in a harddisk, which is referred to as a PC card in this text.



MP-HD260 PC card

Maximum time and number of pictures PC card can store

The MP-HD260 can store:

Moving picture: approx. 20 minutes
 Still pictures: approx. 3,000 shots
 Still picture with audio: approx. 1,000 shots with each 10sec. audio

- * The number of still pictures that can be stored may decrease as their video scene contents become more complicated. The recordable time of still picture with audio is the maximum time when one still picture and audio only are stored. Use the above storable time and number of stills only as a reference.
- * MP-HD260 is already formatted. It is not necessary to format.

Cautions When Using PC Card

For safety, be careful of the following:

CAUTION

- * Do not bring PC card near fire or throw it into fire; it may explode, causing injury or burns.
- * Do not disassemble or modify the unit by yourself. This could cause fire or electric shock.
- * To prevent damage by static electricity, touch metal (door knob, windows frame, etc.) with your hand to discharge it, before handling the unit. Static electricity from the human body could damage the unit.

Generally available PC cards:

Do not use PC cards other than the MP-HD260. We cannot guarantee their operation.

Handle PC card with care as follows to prevent malfunctions or erasure of data :

- * Do not bend the PC card, apply force, allow it to be subject to shocks or drop it.
- * Do not use or store in a place where static electricity or magnetic or electric noise is likely to occur.
- * Do not use or store where temperature and/or humidity are high, in a dusty place, or under highly corrosive environments.
- * Be careful that no dust or foreign object enters through the connector.
- * Do not pull out the PC card, unplug the DC power cord or remove battery during recording or playback. The file being recorded will not be stored, or the stored file could be destroyed.

Removing the PC card:

- * Lay the unit on its back, with the LCD screen facing

up, then remove the PC card from the bottom. Do not put the bottom face down to remove; you could drop the PC card.

When the unit is continuously used for a long time, the PC card will generate heat and its temperature will increase. For safety, the PC card eject lever is locked when the temperature of PC card exceeds the specified one, and it cannot be removed. If the lever is locked, set the CAM/OFF/PLAY switch to OFF and wait for a while. After the temperature drops, the lever will unlock, and you can remove the PC card.

- * When the CAM/OFF/PLAY switch is set to CAM or PLAY, the eject lever will not work. To remove the card, check to see if the switch is set to OFF, with the unit powered by the charged battery in it or the AC adapter/charger connected to AC outlet.
- * When the unit is powered by the AC adapter/charger, do not unplug the DC cord from unit or AC adapter/charger from AC outlet, with the CAM/OFF/PLAY switch set to CAM or PLAY; you cannot remove PC card. Before unplugging them, make sure that the switch is set to OFF.
- * When the PC card eject lever does not work because the unit is not powered by the battery or AC adapter/charger, turn on the unit, set the CAM/OFF/PLAY switch to OFF and then unlock the lever.

Stored data:

- * It is recommended that you store valuable data in your personal computer or other storage devices after each recording.
- * The recorded data may be erased when the PC card is affected by electric noise or becomes faulty or is repaired, or if you or your friends make a mistake in using the unit. We cannot accept any responsibility of compensating for damages due to erasure of recorded data.

■ Viewing the On-Screen Display

Various types of information appear on the LCD monitor. Here are meaning of each indication and how to interpret them.

- * Note that all the following indication do not indicates at the same time.
- * Although a color text appears on the built-in LCD monitor, a white text appears on the TV screen.

[REC MODE]

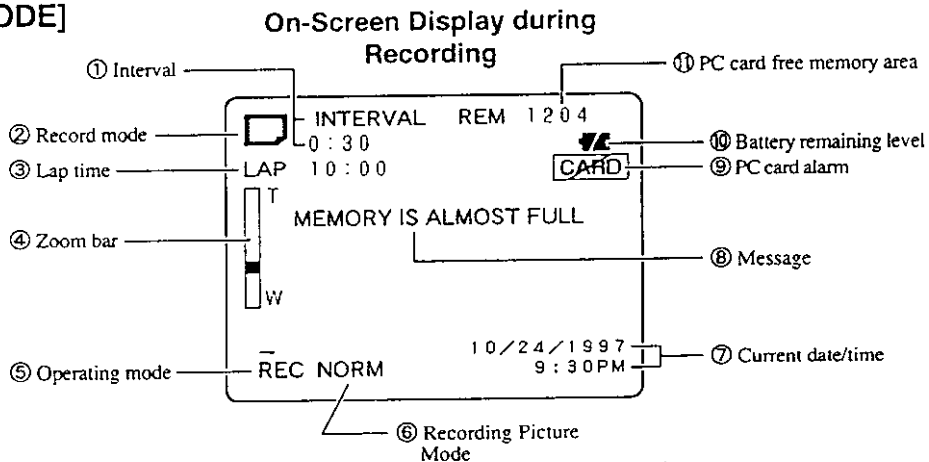

- ① **INTERVAL**: Appears during still picture recording mode if the interval has been set. This indicates the interval at which still pictures are recorded and can be set to 30 seconds, 1 minute or 5 minutes. If this indicator does not appear, normal still picture recording will be engaged.
- ② **Record mode**: This indicates the current recording file type that which can be switched by pressing the REC MODE/THUMBNAIL button. You can select one of four modes:
 - : Moving picture (MPEG1 Format)
 - : Still picture (JPEG Format)
 - : Consecutive recording of still pictures (JPEG Format, 2 pictures/sec. and 5shots)
 - : Still picture with audio (JPEG Format and MPEG Audio)
- ③ **Lap time**: This appears when you select moving pictures or still picture with audio, and indicates the elapsed time since the REC button was pressed.
- ④ **Zoom bar**: This appears when the ZOOM/VOL button is pressed during recording, and indicates how the zoom is engaged in 10 settings from W (wide) to T (tele). The magnification in the optical zoom range is shown in white and that in the digital zoom in yellow. If zoom is pressed, the zoom bar will be displayed for three seconds even when the indicator "FF" appears in the on-screen display.
- ⑤ **Operating mode**: This indicates what mode the MP-EG10W is in currently - recording, playback, etc. - with letters and symbols. See "Operating Mode Indicators" for details.
- ⑥ **Recording moving Picture Mode**: The current moving picture mode appear during recording.
 - FINE: Good Picture, Short Recording Time
 - STN: Normal Picture, Normal Recording Time
- ⑦ **Current date/time**: The current date and time appear during recording. If incorrect date and time appear, correct them.
- ⑧ **Message**: Appears as required.
- ⑨ **PC card alarm**: This appears when a PC card is not inserted or non-usable card is inserted.
- ⑩ **Battery remaining level**: This indicates the battery remaining level with graphics.
 - : Full charge (lights white)
 - : Middle level (lights white)
 - : Low level (flashes white)
 Charge the battery in the low level (see page 20). Connecting the AC adapter/charger causes the middle indicator to light. ()
- ⑪ **PC card free memory area**: This indicates the free memory area on PC card for recording in terms of recording time left or the number of recordable still pictures.

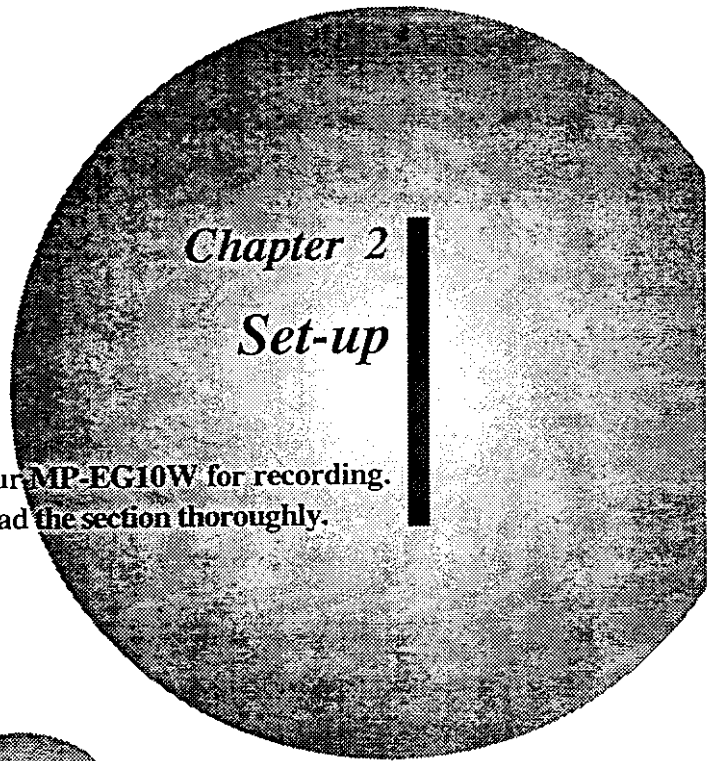
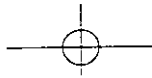

This section explains how to set up your **MP-EG10W** for recording. Before you start to record, be sure to read the section thoroughly.

Charging battery pack	20
Loading the battery pack	21
Using power supply from AC outlet	22
Loading the PC card	23
Setting the date and time	24
Inserting battery into the remote control	27
Tips for skillful use of the MP-EG10W	28

■ Loading the Battery Pack

Load the battery pack in the MP-EG10W by the following procedure:

1 Open the battery compartment lid.

Press the BATT. EJECT button downward. The battery compartment lid will open.

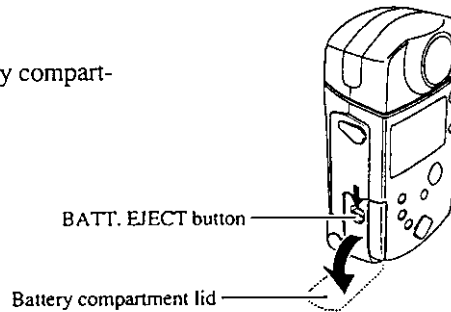

2 Load the battery pack.

Load the battery pack in the direction of the arrow until it is fixed securely.

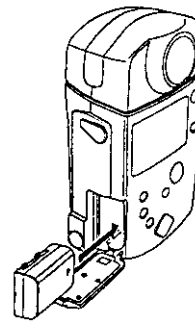

3 Close the battery compartment lid.

* If the battery pack is not inserted correctly, the lid will not close completely. If this happens, re-insert the battery pack correctly.

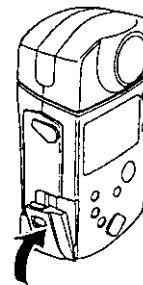

Removing the battery pack

Press the BATT. EJECT button downward to open the lid and push the lever in the direction of the arrow. The battery pack will be ejected by spring force.

- * Do not drop the battery pack when removing it; this could result in malfunction.
- * Do not remove the battery pack during recording or playback. If it is removed during recording, file will not be recorded.

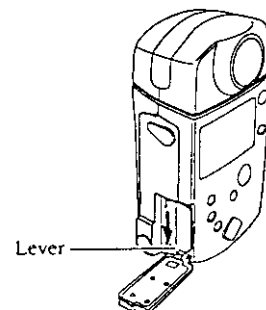

■ Loading the PC Card

Set the CAM/OFF/PLAY switch to OFF before inserting or removing the PC card.

- * Do not use PC cards other than that specified (MP-HD260).
- * Do not attempt to attach an adhesive tag, etc. to the PC card to remove it easily. If the PC card is removed while the MP-EG10W is operating, it could result in malfunction.

1 Open the lid of the PC card insertion slot.

Loosen the screw and remove the lid.

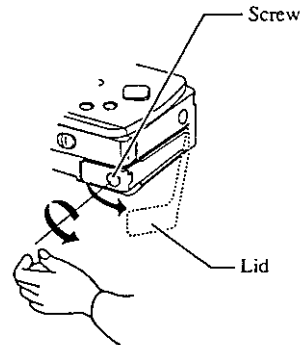

2 Insert the PC card.

With the card surface up, insert the PC card until it is fixed securely into the slot.

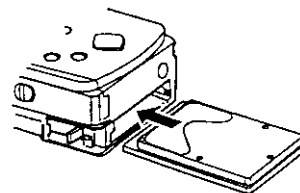

3 Close the lid of the PC card slot.

Attach the lid over the slot and screw up.
(Use fingers to screw up when you close the lid of the PC card slot.)

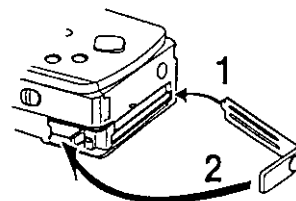

Removing the PC card

Set the CAM/OFF/PLAY switch to OFF and loosen the screw to remove the lid. Lay the MP-EG10W on its side in a horizontal place and push the eject lever. The PC card will be removed.

- * Be careful not to drop the PC card as this could damage it.

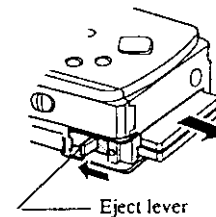

When the eject lever does not move

See "Troubleshooting Guide", or check the following two items:

- If the CAM/OFF/PLAY switch is set to CAM or PLAY, the eject lever will not move. Set it to OFF, and power the MP-EG10W from the charged battery pack or AC adapter/charger.
- If the PC card becomes hot after the MP-EG10W is used for a long time, the eject lever will not work even if the CAM/OFF/PLAY switch is set to OFF, for safety reasons. In this case, leave the MP-EG10W as it is for 10-20 minutes to cool the PC card. When the temperature is low enough, the eject lever can be operated.

4 Select DATE.

Press the ▼ (R.SEARCH) button to select DATE.

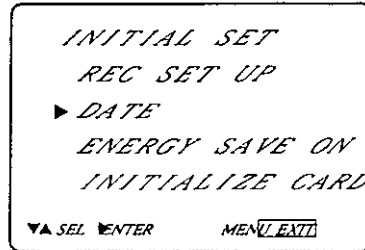
**5** Display the DATE SET screen.

Press the ► (PLAY) button.
The DATE SET screen will appear.

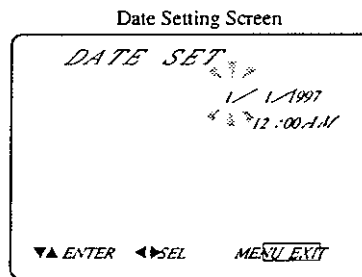
**6** Set the correct date and time.

Press the ► (PLAY) or ◀ (STOP) button until the digit you want to set flashes, then press the ▲ (F.SEARCH) or ▼ (R.SEARCH) button to increase or decrease the number.

7 Finish the date/time setting.

Press the MENU button.

The date/time setting will be completed and the DATE SET menu will disappear, after which the original picture will be restored.

As soon as MENU is pressed, the clock will start counting from the set date and time.

■ Inserting Battery into the Remote Control

Insert the provided CR2025 lithium battery into the remote control.

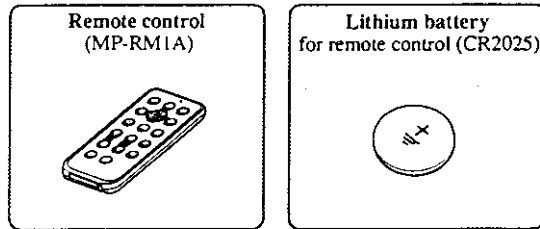

1 Pull out the battery holder.

Push the tab in the direction of the arrow and hold it, then pull out the battery holder.

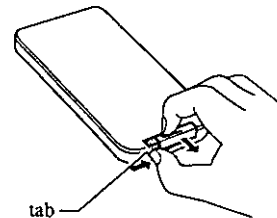

2 Insert the battery with the (+) terminal up.

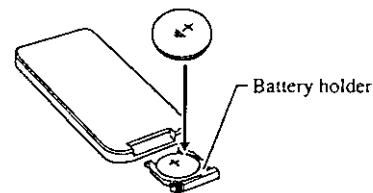

3 Replace the battery holder.

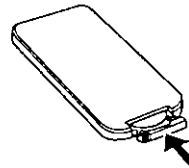

Life of lithium battery

The life of the lithium battery is about one year.

WARNING : KEEP THE BATTERY AWAY FROM CHILDREN AND PETS. IF SWALLOWED, CONSULT A PHYSICIAN IMMEDIATELY FOR EMERGENCY TREATMENT.

Note : Replace remote control battery with 3V micro lithium battery, such as Maxell CR2025 or its equivalent.

Cautions :

- Dispose of battery safely in accordance with local laws. Do not dispose of in fire.
- Do not short circuit the battery.
- Do not take the battery apart.
- Do not hold the battery with metallic tweezers.
- Do not re-charge the battery.

Note : Keep the battery in a dark, cool, dry place.

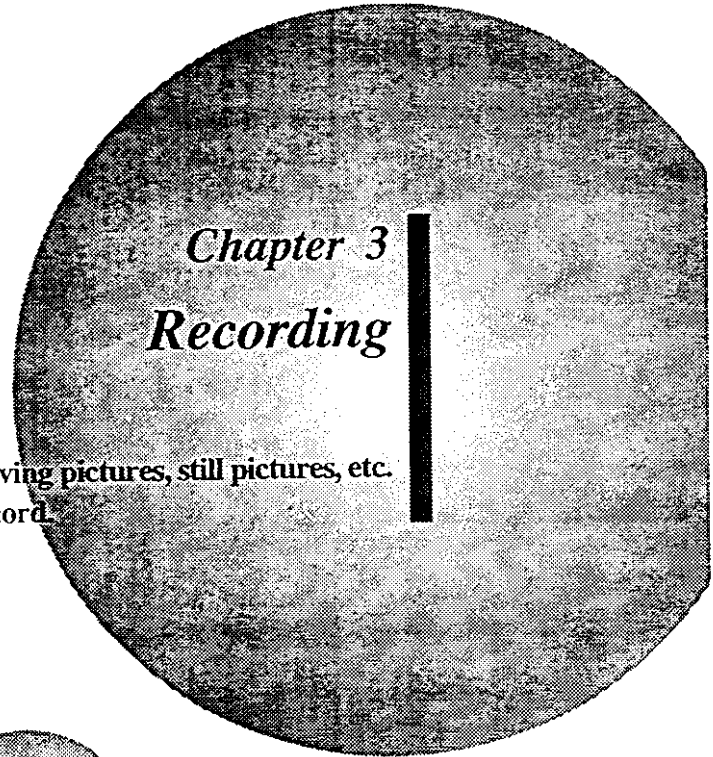
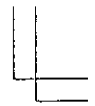
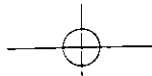

This section explains how to record moving pictures, still pictures, etc.
Read thoroughly before starting to record.

Rotating the camera block and attaching the sunshade	30
Recording moving pictures	31
Recording still pictures	33
Recording still pictures at intervals	34
Recording consecutive still pictures	35
Recording a still picture with audio	36
Recording image of your portrait using the remote control	37

Do not expose the MP-EG10W to shocks during recording. The file being recorded will not be stored.

Be sure you first set the switch to OFF even if you want to set it to PLAY immediately.

If you don't, the MP-EG10W could malfunction.

Recording Moving Pictures

The MP-EG10W records moving pictures and audio.

* The illustrations used in the following text may be different from the actual pictures.

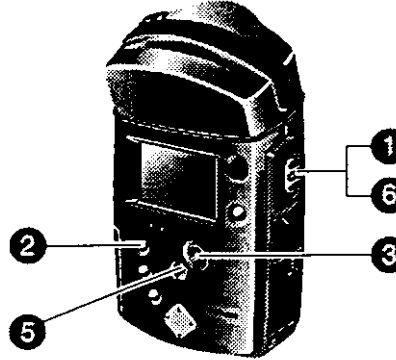

1 Set the CAM/OFF/PLAY switch to CAM.

Hold down the red button at the center of the switch and set the switch to CAM. The image from the lens will appear on the LCD monitor, and the MP-EG10W will enter the record pause mode ("PAUSE" will appear).

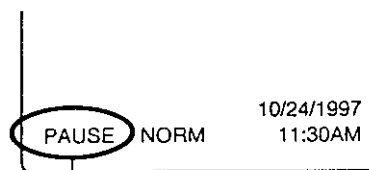

Indicates that the MP-EG10W is in the record pause mode.

2 Check that the "Ⓜ" record mode indicator appears.

If the "Ⓜ" moving picture record mode indicator does not appear, press the REC MODE/THUMBNAIL button repeatedly until it does.

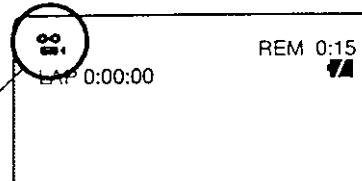

Record Mode Indicator

3 Adjust the image size of subject.

Press the ZOOM/VOL button to adjust the image size of subject. Pressing T (tele) magnifies the image, and pressing W (wide) makes it smaller.

* When the ZOOM/VOL button is pressed, the zoom bar will appear on the left end of the LCD monitor.

Zooming

The MP-EG10W can zoom in on a subject and enlarge it up to 6 times, 3 times the optical zoom multiplied by 2 times the digital zoom. When the MP-EG10W enters the digital zoom area, the zoom bar will change from white to yellow in the LCD monitor, and the picture will be slightly rough in this area.

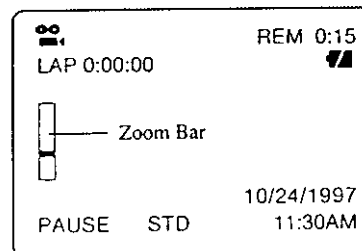

Recording Still Pictures

* If a still picture has been recorded, the remaining number of storable still pictures (REM) which appears in the on-screen display may not decrease. See "Remaining number indicator of storable still pictures".

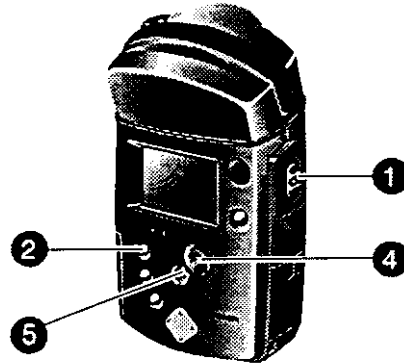

1 Set the CAM/OFF/PLAY switch to CAM.

Hold down the red button at the center of the switch and set the switch to CAM. The image from the lens will appear on the LCD monitor, and the MP-EG10W will enter the record pause mode.

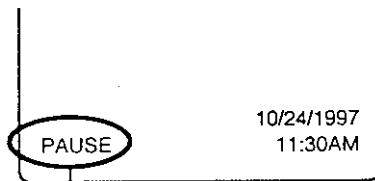

Indicates that the MP-EG10W is in the record pause mode.

2 Set the record mode indicator to "□".

Press the REC MODE/THUMBNAIL button repeatedly until the '□' still picture record mode indicator appears on the LCD monitor.

Record Mode Indicator

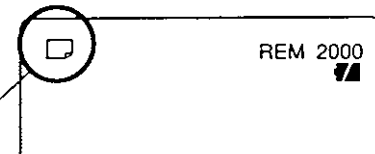

3 Check that the interval indicator is off.

If "INTERVAL" appears on the monitor, interval recording will be made at the displayed "INTERVAL".

Check that "INTERVAL" is not displayed.

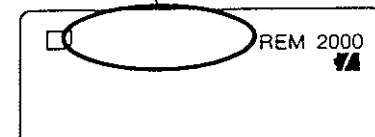

4 Adjust the image size of subject.

Press the ZOOM/VOL button to adjust the image size of subject. Pressing T (tele) magnifies the image, and pressing W (wide) makes it smaller.

* See "Zooming" for details of zoom.

* When the ZOOM/VOL button is pressed, the zoom bar will appear on the left end of the LCD monitor.

5 Record.

Press the REC button to start recording. The REC indicator will blink. The image at the moment the button is pressed will be recorded as a still picture.

* The shutter speed varies from 1/4 to 1/800 second automatically, according to the brightness of subject. If the subject is dim, the shutter speed will be a maximum of 1/4 second, so be careful of camera movement.

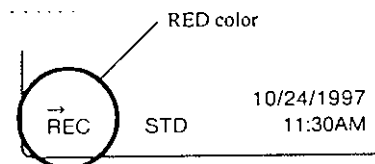

Recording Consecutive Still Pictures

This record mode allows you to automatically record five consecutive still pictures at a speed of about two pictures per second.

* If the brightness of subject changes abruptly during consecutive recording, it could result in overexposure or underexposure.

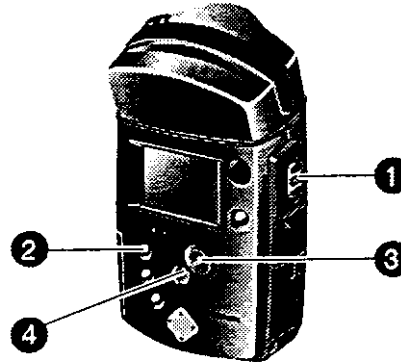

1 Set the CAM/OFF/PLAY switch to CAM.

Hold down the red button at the center of the switch and set the switch to CAM. The image from the lens will appear on the LCD monitor, and the MP-EG10W will enter the record pause mode ("PAUSE" will appear).



Indicates that the MP-EG10W is in the record pause mode.

2 Set the record mode indicator to "☐".

Press the REC MODE/THUMBNAIL button repeatedly until the "☐" consecutive record mode indicator appears on the LCD monitor.

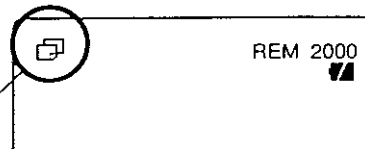

Record Mode Indicator

3 Adjust the image size of subject.

Press the ZOOM/VOL button to adjust the image size of subject. Pressing T (tele) magnifies the image, and pressing W (wide) makes it smaller.

* See "Zooming" for details of zoom.

* When the ZOOM/VOL button is pressed, the zoom bar will appear on the left end of the LCD monitor.

4 Record.

Hold down the REC button.

Five consecutive still pictures will be recorded at a speed of about two pictures per second, after which recording will stop.

If you release the REC button during consecutive recording, recording will stop at the moment you release the button.

* If you are recording a dark scene or a subject with complicated patterns, the consecutive recording speed may be one picture per second.

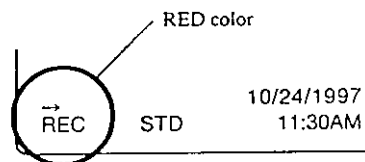

Remaining number indicator of storable still pictures

If a still picture whose size is little has been recorded, the remaining number indicator may not change. Please understand in advance that this does not indicate a fault.

■ Recording Image of Your Portrait Using the Remote Control ■

Place the MP-EG10W on the stand and turn the camera block so the lens faces you. You can record yourself using the remote control.

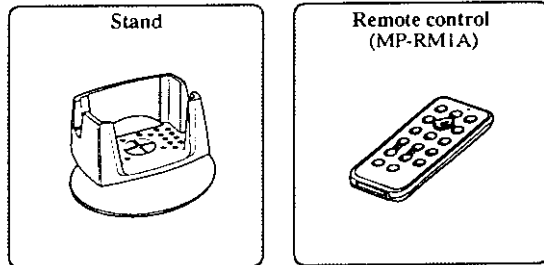

1 Turn the camera block.

Turn the camera block so the lens faces the same direction as the LCD monitor does.

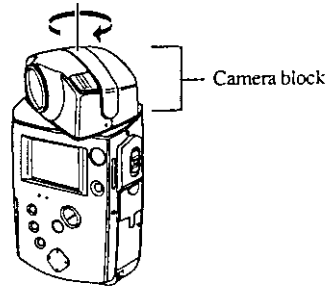

2 Install the MP-EG10W.

Place the stand in a flat, stable position, and install the MP-EG10W on the stand as shown in the figure.

- * Select a place where there are no obstacles between you and the MP-EG10W. If there is an obstacle between the remote control and MP-EG10W's infrared receiver, you cannot operate the MP-EG10W with the remote control.
- * Be sure to select a stable installation place. Installing the MP-EG10W in an unstable place is dangerous.
- * You can use a generally available tripod for a still camera instead of the stand.
- * The stand can be tilted, but cannot be rotated. Do not force to turn it.

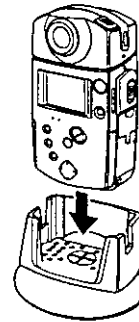

3 Set the CAM/OFF/PLAY switch to CAM and adjust the angle.

Hold down the red button at the center of the switch and set the switch to CAM. Viewing the LCD monitor screen, adjust the angle of the stand.

4 Use the remote control to record.

Point the remote control at the MP-EG10W's infrared receiver to operate.

- * A lithium battery must be inserted into the remote control.
- * Be careful that strong light does not strike the infrared receiver. The remote control distance may be extremely small or no operation can be done.

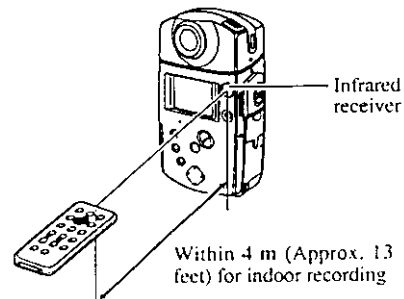

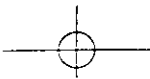

Chapter 5

File Management (Media Navigation)

This section explains how to use Media Navigation for playing recording files and arranging recorded files, editing folder for auto play, etc. Also, see "Operating Files".

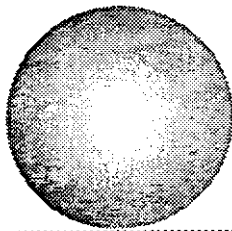
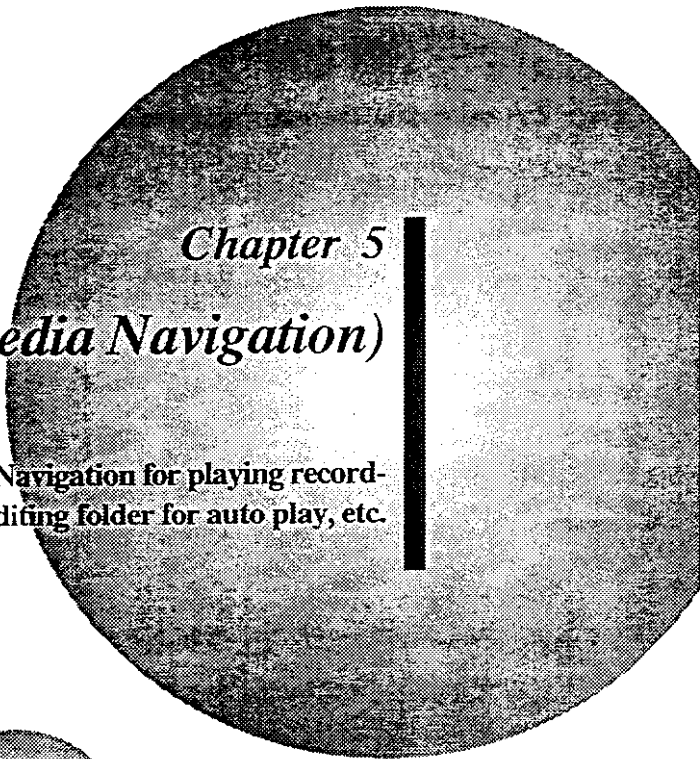

Starting Media Navigation	46
On-screen display and basic operation of Media Navigation	47
Selecting the file and playing it back	49
Transferring files to another folder (CHG FOLD# menu item)	50
Deleting the file	52
Deleting all files in folder	55
Protecting files (LOCK/UNLOCK menu item)	56
Changing the display order of files (CHG ORD menu item)	58
Auto play of desired files	60
Checking free memory area of PC card (REMAIN)	62
Switching thumbnail display on or off	63
Correcting file recording date/time(CHG TIME menu item)	64

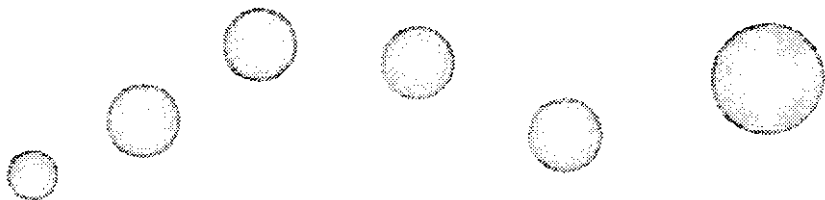
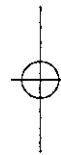

■ On-Screen Display and Basic Operation of Media Navigation. ■

There are two basic screens for Media Navigation - the FOLDER select screen, which displays file number list in folders, and the file select screen, which displays a list of files. Following are details of the displays on these screens and the basic operation methods.

Details of display on FOLDER select screen

This screen allows you to select a folder which contains the files you want to operate, or to select a folder you want to operate (to delete all files in folder).

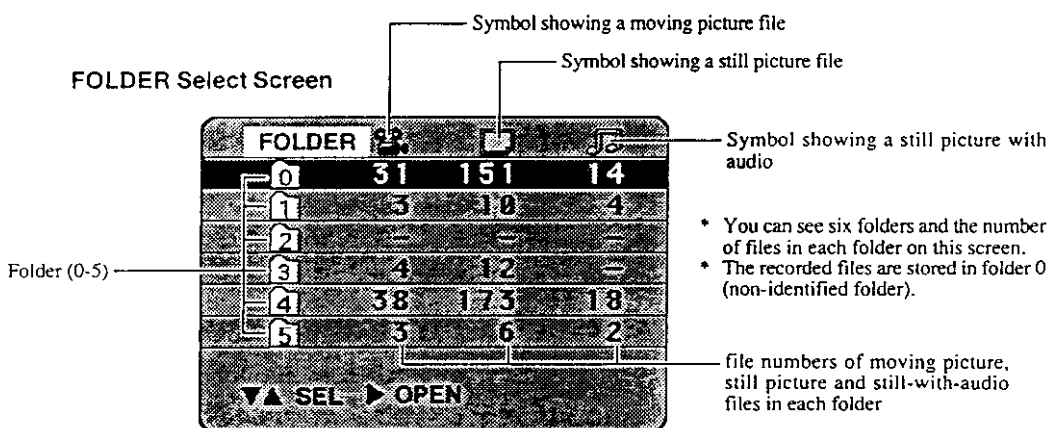

Basic operation on folder select screen

Use the buttons shown below corresponding to ▼, ▲, ▶ and ◀ in the following text. You can use the remote control to operate in the same way.

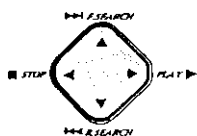

- ▼ : R.SEARCH button
- ▶ : PLAY button
- ▲ : F.SEARCH button
- ◀ : STOP button

To select a folder:

Press ▲ or ▼ to move the highlighted section up or down and select a folder.

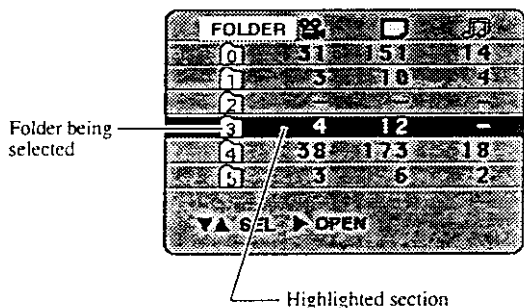

To open the folder:

Press ▶ to open the selected folder, and the file select screen will appear.

To display the menu:

Press the MENU button, and the menu will appear. To switch off the menu, press the button again.

* A menu item displayed in gray text cannot be operated.

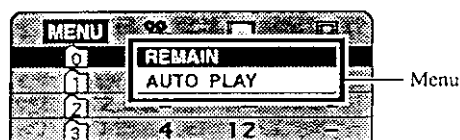

Selecting the File and Playing It Back

If you know the recording date/time of the file you want and the folder containing the file, you can select the file and play it back.

- * Start Media Navigation and display the FOLDER select screen to start.
- * You can also use the remote control to operate.

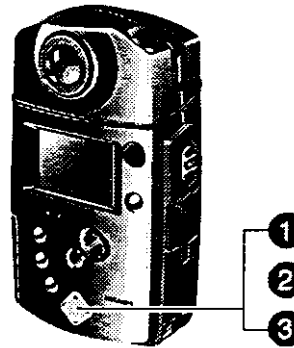
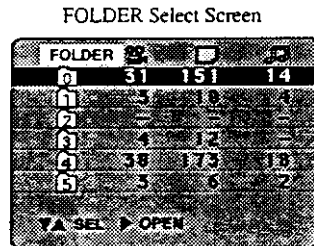

1 Display the file select screen.

Press ▼ or ▲ with the FOLDER select screen to select the folder containing the file you want to play back, and then press ▶.
The file select screen will appear.

File Select Screen (with thumbnails)

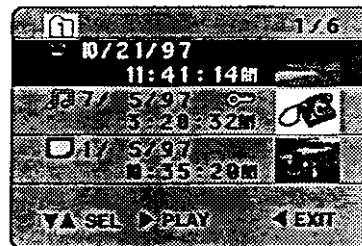

2 Select the file to be played back.

Press ▼ or ▲ to select the file you want to play back and highlight it.

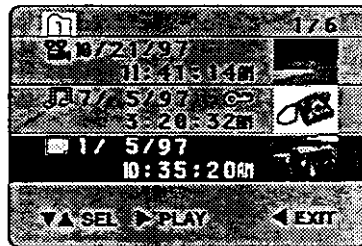

3 Play back the file

Press ▶. The selected file will play back. When playback of the file is finished, it will stop at the final picture of the file.

- * The displayed date and time during playback are fixed at those on which you started recording. The date and time will not change even as picture playback progresses.



Stops at final picture.

To select another file :

Press ◀.

The file select screen will be restored. Perform steps 2 and 3 again.

● If 'FILE ERROR' appears:

If you attempt to play back a file that the MP-EG10W cannot play back, the message 'FILE ERROR' will appear. In this case, the MP-EG10W operation may be malfunctioning. Delete the file to prevent future malfunction.

4 Select the file you want to transfer.

Press ▼ or ▲ to select the file you want to transfer.

* You can also change the folder for files with a lock symbol (🔒).

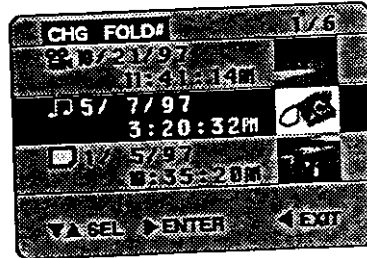

5 Enter the selected file.

Press ►.

The folder symbol will be displayed with the selected file.

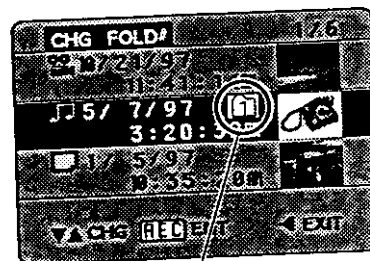

Folder symbol

6 Naming the folder to which you want to transfer the file.

Press ▼ or ▲ to change the folder number to that of the folder to which you want to transfer the file.
Change to the number of the folder you want to transfer the file to.

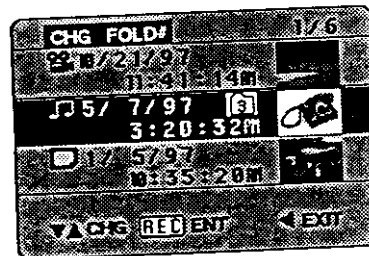

7 Decide the transfer.

Press the REC button (or the START/STOP button on the remote control).

The transfer has been decided and the screen for selecting the file to transfer (the screen in step 4) will be restored. The transferred file has now disappeared from this select screen.

You can continue to change folders of other files by repeating steps 4-7.

* If the folder is empty after all the files are transferred, the message "no file" will appear.

* To cancel the file transfer, press the ◀ button before pressing REC. The transfer will be canceled and the file select screen to transfer (the screen in step 4) will be restored.

8 Exit the CHG FOLD# menu item.

Press the MENU button.

The folder change will end and the file select screen (the screen in step 1) will be restored.

* A transferred file will be displayed at the top of the list of the folder to which the file has been transferred. E51

4 Check the file to be deleted.

Check again, and if it is the file you want to delete, press the **▶** button.

* To cancel deletion, press the **◀** button.

FOLDER Select Screen

FOLDER	31	151	14
0	5	18	4
1	5	12	
2	38	173	18
3	5	6	2

▶ SEL ▶ OPEN

5 Execute deletion.

Press the REC button (or the START/STOP button on the remote control).
The selected file will be deleted and the screen in step 3 will be restored.

- * To finish deletion, press the **◀** button.
- * To delete another file, perform steps 3-5 again.
- * If the folder is empty after all the files are deleted, message "no file" will appear. When you press the **◀** button in this case, the FOLDER select screen will be restored.

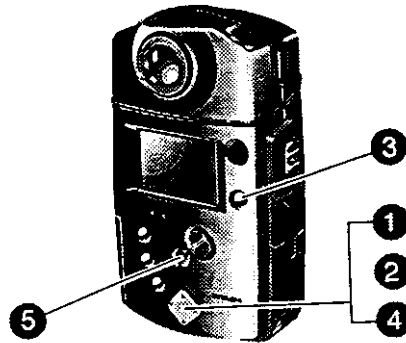

File Select Screen (with thumbnails)

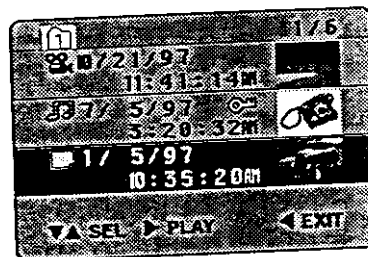
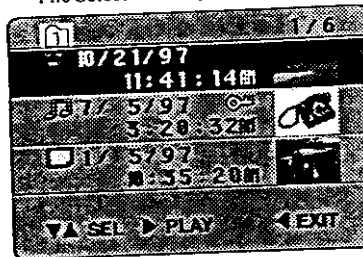

Screen for Deleting Files

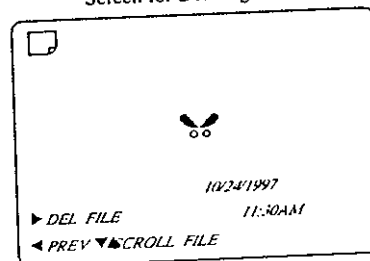

2 Press the DELETE button.

The message "deleting all files of the (selected folder number)" will appear.

* To cancel deletion, press the \blacktriangleleft button or DELETE button.

FOLDER Select Screen

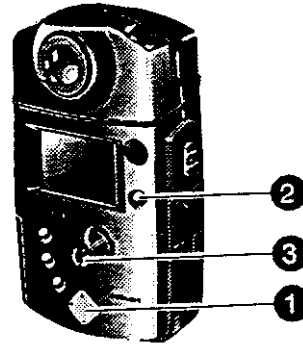
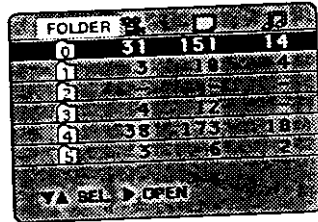

3 Execute deletion.

Press the REC button (or the START/STOP button on the remote control) and deletion will be executed. When deletion is completed, the FOLDER select screen will be restored.

- * All files which have been locked will remain. See page 50 to unlock the protection of file.
- * Make sure you want to delete all files in the folder before pressing the REC button.

File Select Screen (with thumbnails)

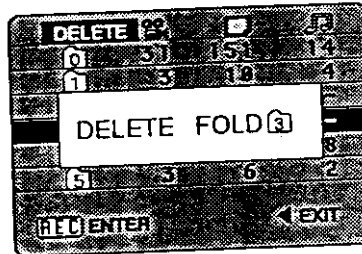
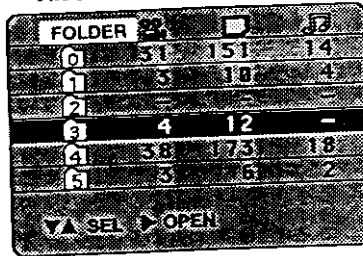

4 Select a file and lock or unlock it.

Press ▼ or ▲ to select the file you want to lock or unlock, and then press the REC button.
Pressing the REC button switches between locking and unlocking of the file and switches the lock symbol on or off.
You will be able to lock or unlock another file by performing steps 4 - 5.

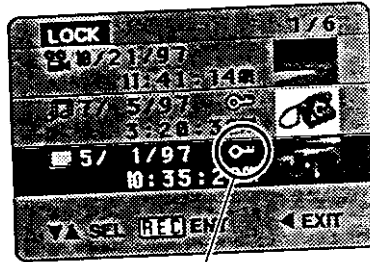

Lock symbol

5 Exit the LOCK/UNLOCK menu item.

Press the ◀ button or MENU button.
Pressing ◀ exits the LOCK/UNLOCK setting and restores the file function setting menu (the screen in step 2).
Pressing MENU exits the LOCK/UNLOCK setting and restores the file select screen (shown in step 1).

4 Select the file whose display order you want to change.

Press ▼ or ▲ to select the file whose display order you want to change.

* You can also change the display order for files with lock symbol (🔒).

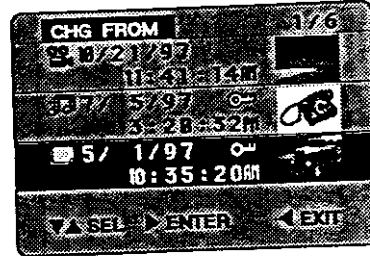

5 Display the screen for selecting the location where you want to move the file.

Press ►.

The screen will change to that for deciding the location where the file is to be moved.

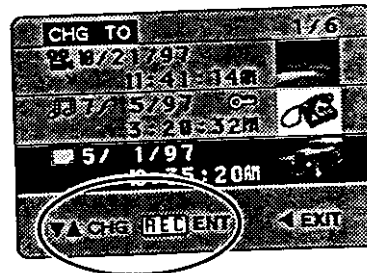

6 Move the file to your designated location.

Press ▼ or ▲.

Each time ▼ or ▲ is pressed, the display position of the selected file will change.

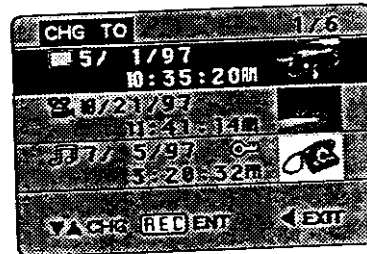

7 Execute the change of the file display order.

Press the REC button (or the START/STOP button on the remote control).

The change of display order has been decided. You can continue to change the display order of other files by repeating steps 4-7

8 Exit the CHG ORD menu item.

Press the ◀ button or MENU button.

Pressing ◀ exits the display order change menu item and restores the file function setting menu (the screen in step 2).

Pressing MENU exits the display order change menu item and restores the file select screen (shown in step 1).

Auto play specifying files in folder

You can specify a file in the folder and start auto play from that file, followed by all files listed above that file.

- * Start Media Navigation (see page 46) and display the FOLDER select screen to start.
- * See "Changing the Display Order of Files" on page 58 when you want to rearrange files in a folder.
- * You can also use the remote control to operate.

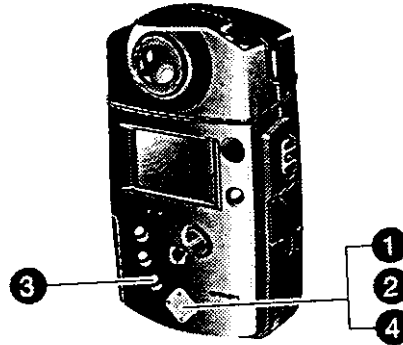
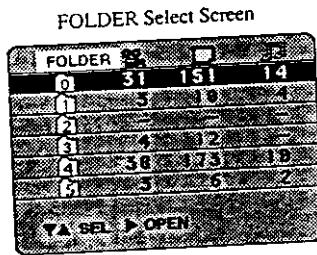

1 Select a folder.

Press ▼ or ▲ with the FOLDER select screen to select the folder containing the files for auto play, and then press ►. The file select screen will appear.

File Select Screen (with thumbnails)

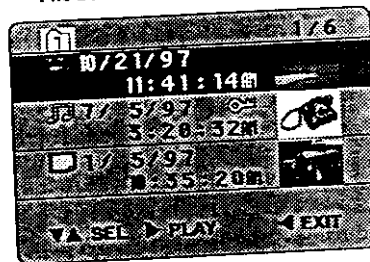

2 Select the file.

Press ▼ or ▲ to select the file from which you want to start auto play.



3 Display the menu.

Press the MENU button to display the menu.

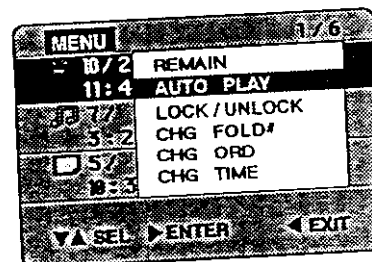

4 Select AUTO PLAY.

Press ▼ or ▲ to select AUTO PLAY, and then press ►. Auto play will start from the selected file, which will be followed by files listed above this one in sequence. When auto play of the top file in the list is finished or press ◀, the file select screen will be restored.

Switching Thumbnail Display On or Off

You can switch the thumbnail display on and off with the file select screen. If thumbnail display is switched off, you can display six files on the screen at a time.

- * Start Media Navigation (see page 46) and display the FOLDER select screen to start.
- * You can also use the remote control to operate.

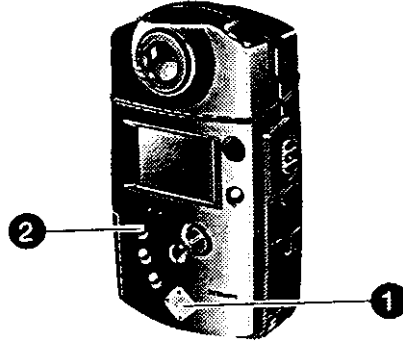
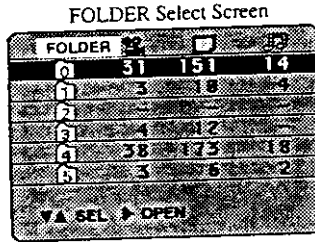

1 Display the file select screen.

Press ▼ or ▲ with the FOLDER select screen to select a folder with files, and press ►.

- * When you switch off a thumbnail, no thumbnails will be displayed no matter which folders you select.

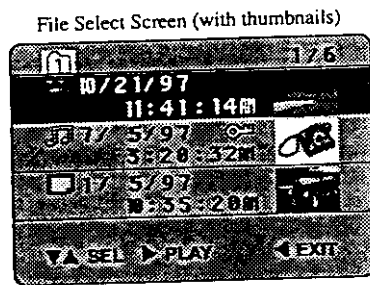

2 Press the REC MODE/THUMBNAIL button.

Thumbnails will disappear and six files will be displayed on one screen. Pressing the button again switches on the thumbnail display.

- * When using the remote control, press the REC MODE/THUMBNAIL button.
- * You cannot switch on or off the thumbnail display while the menu

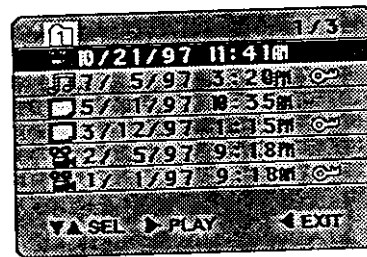

If the thumbnail display is not possible with files recorded by equipment other than MP-EG10W, ? will appear in place of thumbnails.

4 Select the file where you want to correct the recording date/time.

Press ▼ or ▲ to select the file whose recording date/time you want to correct, and then press ►.

The month displayed in the selected file will be highlighted.

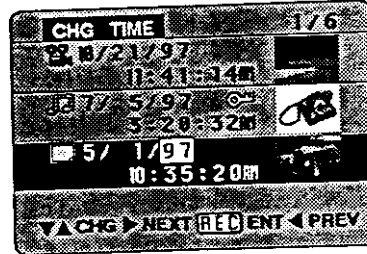

5 Correct the recording date/time.

Press ► or ◀ to highlight the number you want to correct, and then press ▲ or ▼ to increase or decrease it.

* The seconds display counts up or down in 2-second units.

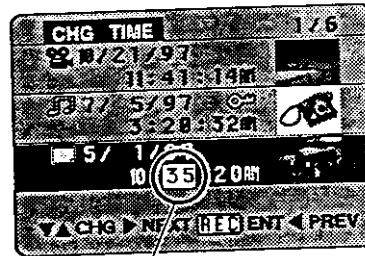

Highlight the date/time you want to correct.

6 Enter the corrected date/time.

After correcting all the incorrect numbers, press the REC button (or the START/STOP button on the remote control).

You can continue to change file recording date/time by repeating steps 4 - 7.

* To cancel change of recording date/time, press the MENU button before pressing REC. The recording date/time will not change, and recording time/date change menu will finish.

7 Exit the CHG TIME menu item.

Press the ◀ button or MENU button.

Press ◀ exits the recording date/time correct menu item and restores the file function setting menu (the screen in step 2).

Pressing MENU exits the recording date/time correct menu item and restores the file select screen (shown in step 1).

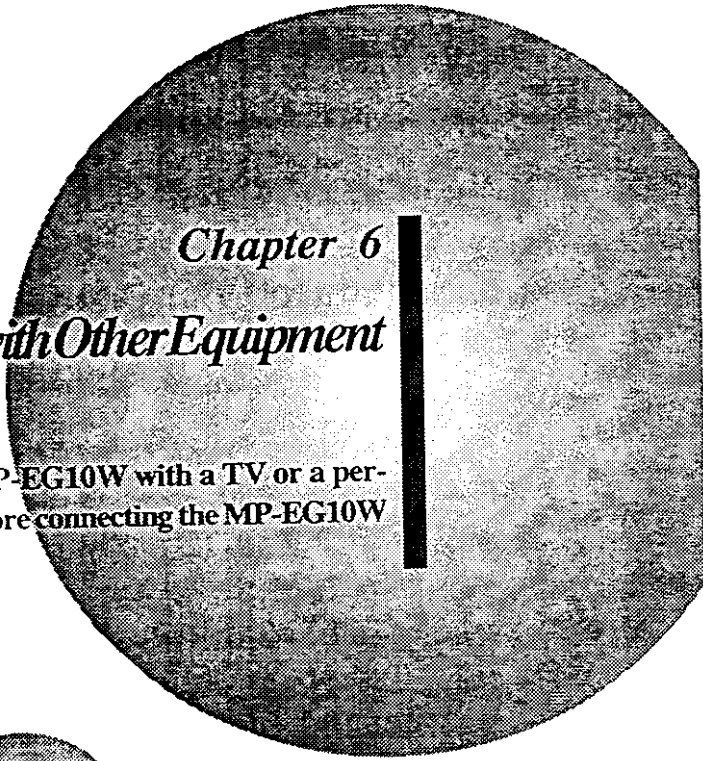
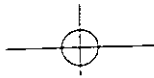

Chapter 6

Using the MP-EG10W with Other Equipment

This section explains how to use the MP-EG10W with a TV or a personal computer. Read it thoroughly before connecting the MP-EG10W to a TV or personal computer.

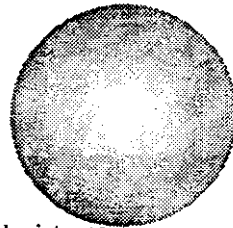

Connecting to TV and viewing playback pictures	68
Personal computers to which MP-EG10W can be connected	69
Connecting to your personal computer	70
Transferring files to your personal computer	71
Personal computers to which files can be transferred directly	72

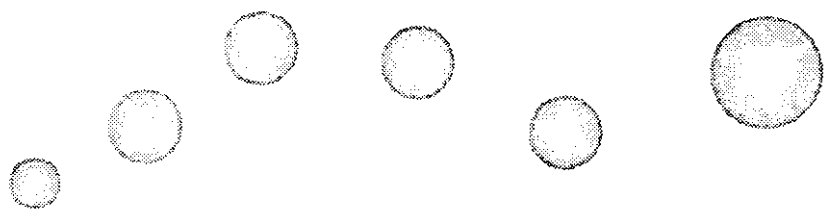
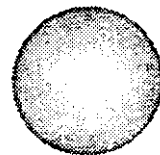
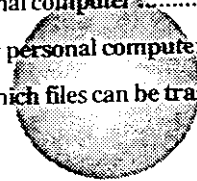

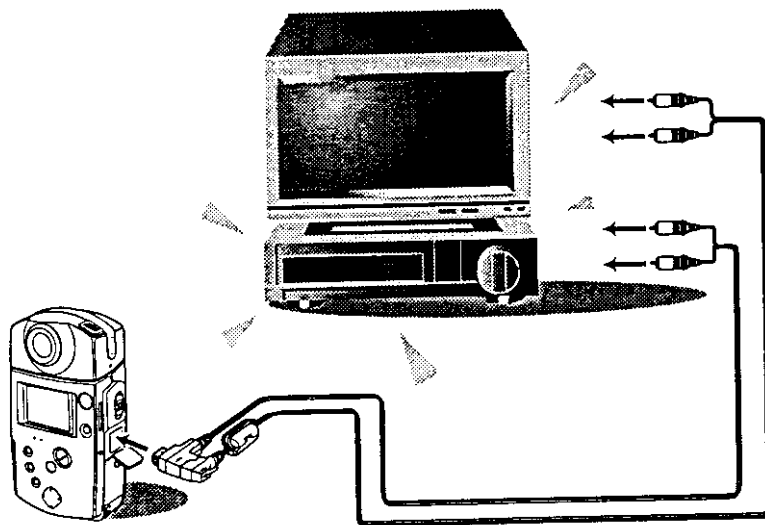
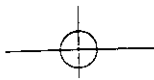

■ Connecting to Your Personal Computer

There are two methods for connecting the MP-EG10W to your personal computer.

Connection with an exclusive ISA board:

For connection to an IBM® PC/AT® compatible desktop personal computer, you need the ISA interface kit. See "Available Accessories".

- * The exclusive transfer application software PureVi is stored in the CD-ROM packed with the MP-EG10W.
- * The ISA communication driver is packed with the ISA interface kit.

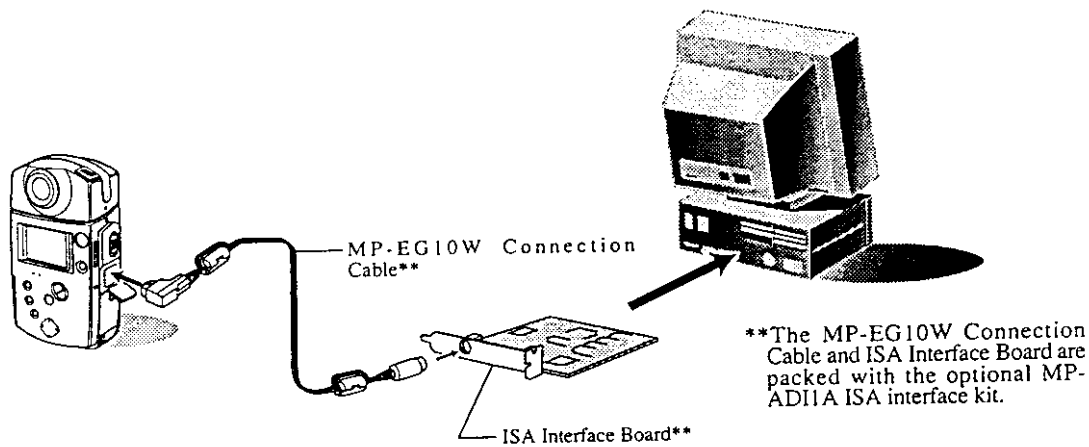

WARNING : The MP-EG10W Connection Cable must be connected to ISA Interface Board or ECP Adapter.
If the MP-EG10W Connection Cable is connected to another jack, MP-EG10W and personal computer may be broken down.

Connection to SCSI port for Macintosh™:

For connection to a Macintosh personal computer, you need the SCSI interface kit. See "Available Accessories".

- * The exclusive transfer application software PRESTAGE is stored in the CD-ROM packed with the SCSI interface kit.

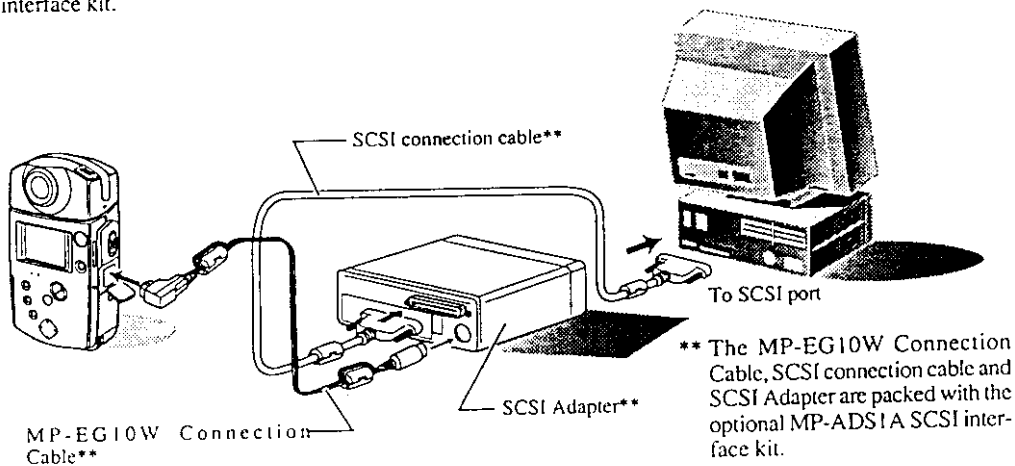

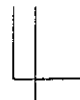
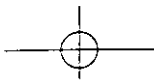

■ *Personal Computers to which Files Can Be Transferred Directly* ■

If your notebook-sized personal computer has a PC card type III slot, or your personal computer has a PC card reader, insert the PC card into the computer to transfer data directly to the computer.

- * Use the PureVi exclusive transfer application software when transferring files on PC card to the computer.
- * The PureVi transfer application software is stored in the CD-ROM packed with the MP-EG10W.
- * Do not use the PC card as a storage device for a personal computer. If you do so, we cannot guarantee the fidelity of the stored data and subsequent MP-EG10W operation.

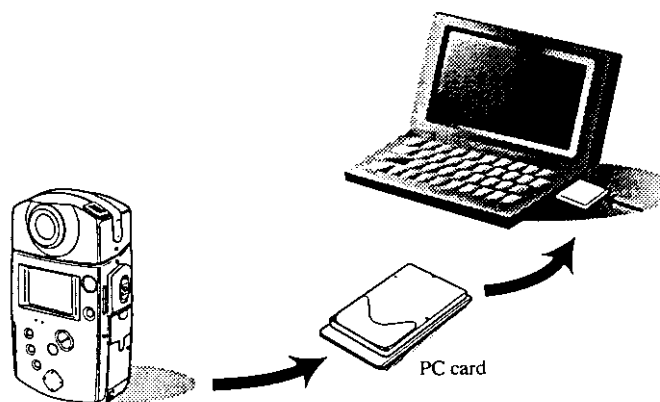

■ *Tips on Battery Pack*

The MP-EG10W uses a lithium-ion rechargeable battery pack. Make sure you understand the performance and characteristics of this battery for skillful and safe use.

Charging

Always charge the battery just before using the MP-EG10W.

If you store the battery after charging without using the MP-EG10W, the battery will discharge on its own. Therefore, it is recommended that you do not charge immediately after using the MP-EG10W, but immediately before using it. It is not necessary to discharge the battery or use it up.

Charge the battery where the ambient temperature is 50-86°F (10-30°C). The lower the temperature, the more difficult the charging.

To ensure good battery performance, the MP-AC1A exclusive adapter/charger has a protection circuit which stops charging automatically when the temperature is too low. Therefore, the battery cannot be charged at a temperature of 41°F (5°C) or less.

Storing

Remove the battery from the MP-EG10W and store it in a cool place.

Storing it at a high temperature could shorten the life of the battery.

Usable time

A fully charged battery can power the MP-EG10W to continuously record moving picture for about 40 minutes at normal temperature. However, if you use the zoom and start/stop operation frequently in actual recording, the usable time will be half to one-third of the above. The battery will also discharge in the following cases :

- When the CAM/OFF/PLAY switch is set to CAM (recording pause);
- When the CAM/OFF/PLAY switch is set to PLAY.

Remember that the usable time is reduced when using the MP-EG10W in a cold place.

Battery remaining level indicator

When the remaining battery level is low during recording or recording pause, the message, low battery level, will appear.

A short time after "☐" flashes, the MP-EG10W will turn off automatically to prevent the battery from over-discharging.

When "■" is displayed, the battery may be near full charge "■" or low charge "☐".

Cleaning

Be sure to turn the MP-EG10W off before cleaning it.

If dirt adheres to the LCD screen or lens :

Wipe it off with a soft, dry cloth. When cleaning the LCD screen, do not use force or strike it.

Do not wipe case with benzene or thinner :

The coating of case could peel off or the case could deteriorate. When using a chemical cleaning cloth, follow the instructions for use.

Wipe off dirt on the case with a moist cloth which has been completely wrung out.

When Trouble Messages Appear

Various messages may appear when you are operating the MP-EG10W. Perform troubleshooting accordingly.

Message	Cause	Troubleshooting
MEMORY IS ALMOST FULL	Free memory area of PC card is small.	Stop recording, and delete unnecessary files to increase free memory area, or replace the PC card.
END OF MEMORY	No free memory area of PC card	
INSERT CARD	PC card is not inserted, or PC card that cannot be used with the MP-EG10W is inserted.	Insert PC card, or replace it with the MP-HD260A PC card.
INVALID CARD TYPE	PC card that cannot be used with the MP-EG10W is inserted.	Replace it with the MP-HD260A PC card.
INITIALIZE CARD	PC card which is not initialized has been inserted.	Initialize it (see page 84).
--/--/-- --:--AM (date/time digits flash)	The clock has not been set or the built-in battery has discharged.	Charge the built-in battery (see page 26) and set the date and time (see page 24).
CARD LOCK (flashes) 	The temperature of PC card is too high, because of extended use.	Turn the MP-EG10W off, leave it for 10-20 minutes and wait until the message disappears.

	Symptom	Check to see	Correction	Reference page
During recording	Even when recorded files are few, the number of recordable still pictures is small or audio recordable time is short.	have complicated patterns?	The number of recordable still pictures or the time of recordable audio varies depending on the pattern complication of recorded pictures.	15
	Audio recordable time is short.	Are you recording audio, repeating recording pause?	Since still pictures are recorded during every recording pause, the audio recordable time is short. The audio recordable time also varies depending on audio content.	
	No picture appears on the LCD monitor.	Has LCD OFF been specified?	Press the MENU button to display the SET UP screen, and specify LCD ON.	81
		Is AV cable connected?	Unplug it.	68
	LCD screen is difficult to see.	Is LCD screen adjusted properly?	Press the MENU button to display the SET UP screen, and the adjust the picture with the PICTURE ADJ screen.	82
		Is the MP-EG10W being used outdoors? The LCD screen is difficult to see in a bright place.	Attach the provided sunshade.	30
	Subject cannot be focused.	Is the MP-EG10W too near to the subject?	The MP-EG10W allows macro recording as close as 28 cm (11.2 in.) to the subject at W position of zoom. If it is brought much nearer, the subject cannot be focused.	32
Recording cannot be done.	Are you using the specified PC card?	Use the MP-HD260 PC card.	15	
During Playback	Playback cannot be done if you press the PLAY button.	Is CAM/OFF/PLAY switch set to CAM?	Set it to PLAY.	40
		Was the MP-EG10W subjected to force or shocks?	The MP-EG10W has possibly been destroyed.	
		Was the file recorded by other equipment?	It may be impossible to play the file recorded by other equipment (MPEG file, etc. transferred from computer). Play the file recorded by the MP-EG10W.	
		Did you operate the file with software (explorer, etc.) other than that provided?	Operating the file in PC card with software other than the one provided could destroy the file.	
	No picture appears on the LCD monitor.	Has LCD OFF been specified?	Press the MENU button to display the SET UP screen, and specify LCD ON.	81

■ Terminology (As of February 1997)

Application software

Software which is run by users on an OS. Typical are word processing software, spreadsheet program, painting software, etc.

CD-ROM (Compact Disk Read-Only Memory)

Large-capacity read-only memory. A compact disc in which files are stored. It is possible to read data at high speed.

CPU (Central Processing Unit)

A component that is the center of computer. It receives data from an input device, computes and stores it, then transfers resultant data to an output device.

Driver software

Software which provides OS with a specified device. Once installed, user need not be concerned about use.

Hard disk

Conventionally, a fixed storage of personal computer. Although it is not as handy as a floppy disk or MO disk, it can store mass data at high speed. Recently, detachable and card type hard disks has been marketed.

Homepage

Introduction for information to be provided on Internet, which can be created using still pictures, audio and moving pictures.

ISA (Industry Standard Architecture)

16-bit bus interface standard used with IBM® PC/AT® compatible machines.

Initialization

A task done so that hard disk, MO disk, floppy disk, etc. can be used with personal computers. This is also referred to as formatting.

Internet

More advanced network of computer networks. In this system, computers in the world are connected to one network.

JPEG (Joint Photographic coding Experts Group)

One of the national standards for color still picture compression system. This system has become popular worldwide and is used to create Internet homepage, etc. The file extension is generally ".jpg".

MO disk (Magnetic Optical disk)

A storage medium, from/to which data is read and written using the magnet-optical system. It is able to store much more data.

MPEG 1 (Moving Picture Experts Group 1)

One of the international standards for color moving picture compression system. This is one of the most efficient moving picture compression systems, as of February, 1997. An MPEG 1 decoding hardware or MPEG 1 decoding software is necessary to play back pictures. The file extension is generally ".mpg".

Multimedia Contents

Electronic publications configured by various types of data, including characters, moving pictures, still pictures, audio, etc.

OS (Operating System)

Software that manages other programs, data, hardware, etc., to process the task given to computer.

PC card

A credit-card sized card that can be easily inserted into personal computer from outside. PC card is the formal name for cards conforming to the PCMCIA (personal computer memory card international association) standard. PC cards are divided into type I, II and III, depending on their thickness.

Pentium®

The 32-bit CPU developed by Intel Corporation.

RAM (Random Access Memory)

The memory, from/to which data can be read and written at random.

Thumbnail

A small still picture, used with many types of image indexing software.

Windows® 95 (Microsoft® Windows® 95 Operating System)

The OS developed by Microsoft Corporation, which is very popular as an OS for personal computers.

Major Specifications

Model	MP-EG10W
Power supply	7.2 VDC
Power consumption	6.5 W
Weight	approx. 385 g (MP-EG10W only) approx. 540 g (with MP-BP1A battery pack and MP-HD260 PC card)
Signal format	NTSC
Compression systems	Moving pictures : MPEG1 Still picture : Conforming to JPEG Audio : Conforming to MPEG Audio
Battery usable time	approx. 40 minutes (when recording moving pictures continuously at normal temperature)
Recording medium	MP-HD260 PC card
Speaker output	200mW
Permissible operating temperature/humidity	32-104F (0-40C) / 80% or less
Image sensor	1/4" CCD Total number of pixels: approx. 390,000 Effective number of pixels: approx. 360,000
Built-in microphone	Monaural
Automatic sensitivity adjustment range	20-100,000lux
Minimum required illumination	14 lux for moving pictures 5 lux for still pictures
Liquid crystal display panel	Image size: 1.8" Number of dots: 61,380
Lens	6x zoom lens (when 2x digital zoom is used concurrently) F2.4f=3.6-10.8mm
Minimum distance recording	Possible as close as 28 cm (at W position of zoom)
Maximum recording time*	Moving pictures: approx. 20 minutes Still picture with audio: approx. 4 hours (with MP-HD260 PC card)
Maximum number of recordable still pictures	approx. 3,000 (with MP-HD260 PC card)
External dimensions	83 (W) x 143.5 (H) x 56 (D) mm

* See "PC card".

Specifications are subject to change without notice.

There are pixels which always light on the LCD monitor, but this does not indicate a fault.