

ULTRAVISION®

OWNER'S GUIDE

Model: **48C6**
48" Class (47.61" Diag.)

Serial No. _____

CONGRATULATIONS

Thank you for purchasing this Hitachi product.
Please read these instructions carefully.

For additional assistance please call Toll Free 800.HITACHI (800.448.2244)
or visit our website at www.hitachi.us/tv.
Keep this Owner's Guide for future reference.

Record the model name and serial number of your LCD Television for future reference.
This information is located on the back of the television.





CAUTION
RISK OF ELECTRIC SHOCK
DO NOT OPEN



CAUTION: TO REDUCE THE RISK OF ELECTRIC SHOCK, DO NOT REMOVE COVER (OR BACK). NO USER SERVICEABLE PARTS INSIDE. REFER SERVICING TO QUALIFIED SERVICE PERSONNEL.



The lightning flash with arrowhead symbol, within an equilateral triangle is intended to alert the user to the presence of uninsulated dangerous voltage within the product's enclosure that may be of sufficient magnitude to constitute a risk of electric shock.



The exclamation point within an equilateral triangle is intended to alert the user to the presence of important operating and maintenance (servicing) instructions in the literature accompanying the appliance.

WARNING: TO PREVENT FIRE OR SHOCK HAZARD, DO NOT EXPOSE THIS APPLIANCE TO RAIN OR MOISTURE.
TO PREVENT THE SPREAD OF FIRE, KEEP CANDLES OR OPEN FLAMES AWAY FROM THIS PRODUCT AT ALL TIMES.

CAUTION: TO PREVENT ELECTRIC SHOCK, DO NOT USE THIS TELEVISION'S AC PLUG WITH AN EXTENSION CORD, RECEPTACLE OR OTHER OUTLET UNLESS THE BLADES CAN BE FULLY INSERTED TO PREVENT BLADE EXPOSURE.

WARNING: This equipment has been tested and found to comply with the limits for a Class B digital device, pursuant to Part 15 of the FCC Rules. These limits are designed to provide reasonable protection against harmful interference in a residential installation. This equipment generates, uses and can radiate radio frequency energy and, if not installed and used in accordance with the instructions, may cause harmful interference to radio communications.

However, there is no guarantee that interference will not occur in a particular installation. If this equipment does cause harmful interference to radio or television reception, which can be determined by turning the equipment off and on, the user is encouraged to try to correct the interference by one or more of the following measures:

- Reorient or relocate the receiving antenna.
- Increase the separation between the equipment and receiver.
- Connect the equipment to an outlet on a circuit different from that to which the receiver is connected.

Never place a television set in an unstable location. A television set may fall, causing serious personal injury or death. Many injuries, particularly to children, can be avoided by taking simple precautions such as:

- Using cabinets or stands recommended by the manufacturer of the television set.
- Only using furniture that can safely support the television set.
- Ensuring the television set is not overhanging the edge of the supporting furniture.
- Not placing the television set on tall furniture (for example, cupboards or bookcases) without anchoring both the furniture and the television set to a suitable support.
- Not placing the television set on cloth or other materials that may be located between the television set and supporting furniture.
- Educating children about the dangers of climbing on furniture to reach the television set or its controls.
- Consult the dealer or an experienced radio/TV technician for help.

CAUTION: Changes or modifications not expressly approved by the party responsible for compliance with the FCC Rules could void the user's authority to operate this equipment.

Location of the required Marking

The rating sheet and the safety caution are on the rear of the unit.

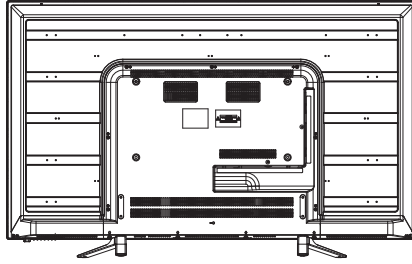

LEAD NOTICE

This product contains lead. Dispose of this product in accordance with applicable environmental laws. For product recycling and disposal information, contact your local government agency or www.eRecycle.org (in California), the Electronic Industries Alliance at www.ecyclingcentral.com (in the U.S.) or the Electronic Product Stewardship Canada at www.epsc.ca (in Canada). **FOR MORE INFORMATION, call 800.HITACHI (800.448.2244) (USA/CANADA).**

 This equipment is a Class II or double insulated electrical appliance. It has been designed in such a way that it does not require a safety connection to electrical earth.

IMPORTANT SAFETY INSTRUCTIONS

- 1) Read these instructions.
- 2) Keep these instructions.
- 3) Heed all warnings.
- 4) Follow all instructions.
- 5) Do not use this apparatus near water.
- 6) Clean only with dry cloth.
- 7) Do not block any ventilation openings. Install in accordance with the manufacturer's instructions.
- 8) Do not install near any heat sources such as radiators, heat registers, stoves, or other apparatus (including amplifiers) that produce heat.
- 9) Do not defeat the safety purpose of the polarized or grounding-type plug. A polarized plug has two blades with one wider than the other. A grounding type plug has two blades and a third grounding prong. The wide blade or the third prong are provided for your safety. If the provided plug does not fit into your outlet, consult an electrician for replacement of the obsolete outlet.
- 10) Protect the power cord from being walked on or pinched particularly at plugs, convenience receptacles, and the point where they exit from the apparatus.
- 11) Only use attachments/accessories specified by the manufacturer.
- 12) Use only with cart, stand, tripod, bracket, or table specified by the manufacturer, or sold with the apparatus. When a cart is used, use caution when moving the cart/apparatus combination to avoid injury from tip-over.
- 13) Unplug this apparatus during lightning storms or when unused for long periods of time.
- 14) Refer all servicing to qualified service personnel. Servicing is required when the apparatus has been damaged in any way, such as power-supply cord or plug is damaged, liquid has been spilled or objects have fallen into the apparatus, the apparatus has been exposed to rain or moisture, does not operate normally, or has been dropped.
- 15) Apparatus should not be exposed to dripping or splashing, and objects filled with liquids, such as vases, should not be placed on the apparatus.



S3125A

IMPORTANT SAFETY INSTRUCTIONS

(continued)

- 16) An outside antenna system should not be located in the vicinity of overhead power lines or other electric light or power circuits, or where it can fall into such power lines or circuits. When installing an outside antenna system, extreme care should be taken to keep from touching such power lines or circuits, as contact with them might be fatal.
- 17) Do not overload wall outlets and extension cords, as this can result in a risk of fire or electric shock.
- 18) Do not push objects through any openings in this unit, as they may touch dangerous voltage points or short out parts that could result in fire or electric shock. Never spill or spray any type of liquid into the unit.
- 19) If an outside antenna or cable system is connected to the unit, be sure the antenna or cable system is grounded to provide some protection against voltage surges and built-up static charges, Section 810 of the National Electrical Code, ANSI/NFPA 70, provides information with respect to proper grounding of the mast and supporting structure, grounding of the lead-in wire to an antenna discharge unit, size of grounding conductors, location of antenna discharge unit, connection to grounding electrodes, and requirements for the grounding electrode.

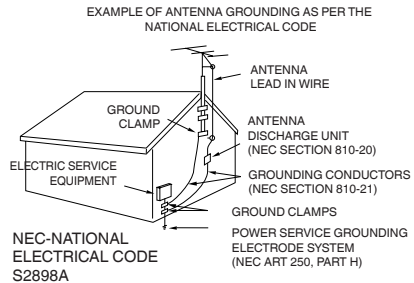

- 20) When replacement parts are required, be sure the service technician uses replacement parts specified by the manufacturer or those that have the same characteristics as the original part. Unauthorized substitutions may result in fire, electric shock or other hazards.
- 21) Upon completion of any service or repairs to this unit, ask the service technician to perform safety checks to determine that the unit is in proper operating condition.
- 22) When you connect the product to other equipment, turn off the power and unplug all of the equipment from the wall outlet. Failure to do so may cause an electric shock and serious personal injury. Read the owner's manual of the other equipment carefully and follow the instructions when making any connections.
- 23) Do not allow the product to output distorted sound for an extended period of time. It may cause speaker overheating and fire.
- 24) This reminder is provided to call the cable TV system installer's attention to Article 820-40 of the NEC that provides guidelines for proper grounding and, in particular, specifies that the cable ground shall be connected to the grounding system of the building, as close to the point of cable entry as practical.
- 25) Sudden high volume sound may cause hearing or speaker damage. When you use headphones, (if the unit is equipped with a headphone jack) keep the volume at a moderate level. If you use headphones continuously with high volume sound, it may cause hearing damage.
- 26) The mains plug is used as the disconnect and shall remain readily operable.

Declaration of Conformity

This device complies with Part 15 of the FCC Rules. Operation is subject to the following two conditions:

(1) This device may not cause harmful interference and (2) This device must accept any interference received, including interference that may cause undesired operation.

For questions regarding this declaration, contact:

©Hitachi America, Ltd.
2420 Fenton Street, Suite 200
Chula Vista, CA 91914-3556
Tel: 800.HITACHI (800.448.2244)
ATTN: Customer Relations

IMPORTANT SAFETY INSTRUCTIONS

(continued)

HOW TO HANDLE THE LCD PANEL

- Do not press hard or jolt the LCD panel. It may cause the LCD panel glass to break and injury may occur.
- If the LCD panel is broken, make absolutely sure that you do not touch the liquid in the panel. This may cause skin inflammation. If the liquid gets in your mouth, immediately gargle and consult with your doctor. Also, if the liquid gets in your eyes or touches your skin, consult with your doctor after rinsing for at least 15 minutes or longer in clean water.

Possible Adverse Effects on LCD Panel: If a fixed (non-moving) pattern remains on the LCD Panel for long periods of time, the image can become permanently engrained in the LCD Panel and cause subtle but permanent ghost images. This type of damage is NOT COVERED BY YOUR WARRANTY. Never leave your LCD Panel on for long periods of time while it is displaying the following formats or images:

- Fixed Images, such as stock tickers, video game patterns, TV station logos, and websites.
- Special Formats that do not use the entire screen. For example, viewing letterbox style (16:9) media on a normal (4:3) display (black bars at top and bottom of screen); or viewing normal style (4:3) media on a widescreen (16:9) display (black bars on left and right sides of screen).

The following symptoms are not signs of malfunction but technical limitation. Therefore we disclaim any responsibility for these symptoms.

- LCD Panels are manufactured using an extremely high level of precision technology, however sometimes parts of the screen may be missing picture elements or have luminous spots.
- Do not install the LCD Panel near electronic equipment that produces electromagnetic waves. Some equipment placed too near this unit may cause interference.
- Effect on infrared devices – There may be interference while using infrared devices such as infrared cordless headphones.

Power source

This television is designed to operate on 100 - 240 volts 50 - 60 Hz, AC current. Insert the power cord into a 100 - 240 volts 50 - 60 Hz outlet.

To prevent electric shock, do not use the television's (AC) plug with an extension cord, receptacle, or other outlet unless the blades can be fully inserted to prevent blade exposure.

Never Connect the television to direct current or anything other than the specified voltage.

Warning

To reduce the risk of fire or electric shock, do not expose this apparatus to rain or moisture.

Caution

Never remove the back cover of the television as this can expose you to very high voltages and other hazards. If the television does not operate properly, unplug the television and call your authorized dealer or service center.

Adjust only those controls that are covered in the instructions, as improper changes or modifications not expressly approved by Hitachi could void the user's warranty.

CONDENSATION

Moisture will form in the operating section of the unit if the unit is brought from cool surroundings into a warm room or if the temperature of the room rises suddenly. When this happens, unit's performance will be impaired. To prevent this, let the unit stand in its new surroundings for about an hour before switching it on, or make sure that the room temperature rises gradually.

Condensation may also form during the summer if the unit is exposed to the breeze from an air conditioner. In such cases, change the location of the unit.

CHILD SAFETY NOTICE

CHILD SAFETY:

It Makes A Difference How and Where
You Use Your Flat Panel Display

Congratulations on your purchase!

As you enjoy your new product, please keep these safety tips on mind:



HITACHI CARES!

- The consumer electronics industry is committed to making home entertainment enjoyable and safe.
- Please note the American Academy of Pediatrics discourages television viewing for children younger than two years of age.
- The home theater entertainment experience is a growing trend and larger flat displays are popular purchases. However, flat panel displays are not always supported on the proper stands or installed according to the manufacturer's recommendations.
- Flat Panel displays that are inappropriately situated on dresser, bookcases, shelves, desks, speakers, chest or carts may fall over and cause injury.

TUNE INTO SAFETY

- One size does NOT fit all. Follow the manufacturer's recommendations for the safe installation and use of your flat panel display.
- Carefully read and understand all enclosed instructions for proper use of this product.
- Don't allow children to climb on or play with furniture and television sets.
- Don't place flat panel displays on furniture that can easily be used as steps, such as a chest of drawers.
- Remember that children can become excited while watching a program, especially on a "larger than life" flat panel display. Care should be taken to place or install the display where it cannot be pushed, pulled over, or knocked down.
- Care should be taken to route all cords and cables connected to the flat panel display so that they cannot be pulled or grabbed by curious children.

WALL MOUNTING: IF YOU DECIDE TO WALL MOUNT YOUR FLAT PANEL DISPLAY, ALWAYS:

- Use a mount that has been recommended by the display manufacturer and/or listed by an independent laboratory (such as UL, CSA, ETL).
- Follow all instructions supplied by the display and wall mount manufacturers.
- If you have any doubts about your ability to safely install your flat panel display, contact your retailer about professional installation.
- Make sure that the wall where you are mounting the display is appropriate.
- Some wall mounts are not designed to be mounted to walls with steel studs or old cinder block construction.
- If you are unsure, contact a professional installer.
- A minimum of two people are required for installation. Flat panel displays can be heavy.



 **CEA**
Consumer Electronics Association
www.CE.org/safety

SAFETY PRECAUTIONS

The unit emits heat when in operation. Do not place any covers or blankets on the unit, this may cause overheating. Do not block ventilation holes, or set up near radiators. Do not place in direct sunlight. When placing on a shelf leave 4 inches (10 cm) free space around the entire unit.

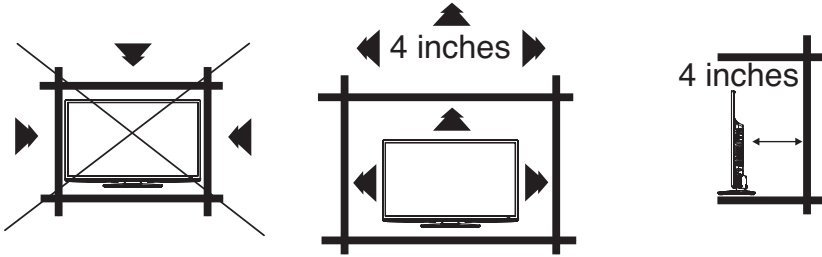

Securing to a Wall

- 1 Use metallic wire (not provided), screw and clamp on the rear of the TV as shown below.
- 2 Keep the TV 4 inches away from the wall, except when mounted using the wall mount bracket, and secure to the wall as shown below:

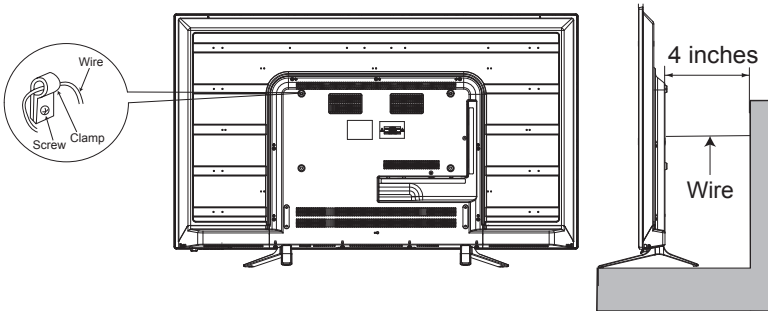

NOTICE FOR TV CABINET

If the unit is placed on a cabinet smaller than the length of the unit, it could result in instability and the unit may tumble over, making a risk of personal, possibly fatal injury. Also, this would seriously damage the product. Accordingly, Hitachi accepts no responsibility or liability for any injuries or property damage resulting from the improper installation.

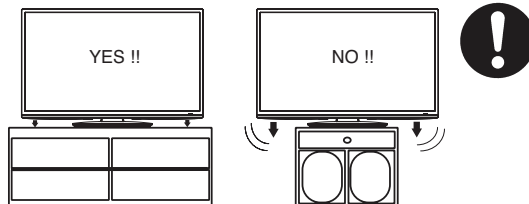

How to attach the stand

NOTE:

- Assure the AC cord is not connected to an AC outlet.
- Before beginning this process, make sure that you have a clean, safe, and cushioned space to work at to avoid any damage to the unit.
- Do not touch or press the LCD screen, the glass might break under pressure.

- 1 Carefully place the TV screen face-down on a clean, cushioned surface.
- 2 Attach the stands to the bottom of the TV by inserting the stand posts into the slits at the bottom of the TV as shown in Fig.1.
- 3 Secure the stands to the TV by using the supplied 4 screws as shown in Fig. 2.

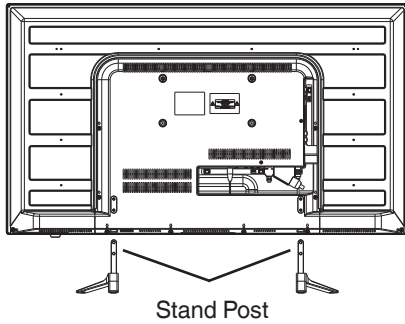

Fig. 1

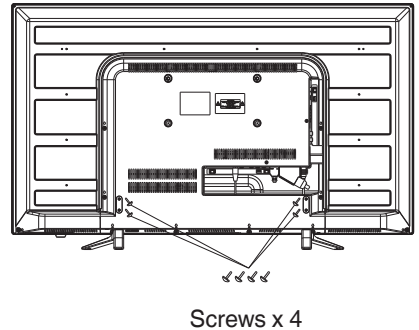

Fig. 2

- Be sure to follow the above instructions. Insufficient tightening or incorrect installation of the stand will not support your TV correctly, and could result in damage or injury from tip-over.

How to remove the stand

When you transport this product, remove the stand and pack it flat against the back of the unit in the carton. To remove the stand, perform the above steps in reverse order. When you mount the TV on the wall, remove both stands. To disconnect the stand remove the screws from the bottom of TV.

Note: Before wall-mounting, please carefully check the location of the TV's mounting holes.

Contents

Before using your unit

IMPORTANT SAFETY INSTRUCTIONS	3
CHILD SAFETY NOTICE	6
SAFETY PRECAUTIONS	7
How to attach the stand	8
How to remove the stand	8
Contents	9
Features.....	10
Location of controls.....	11
Remote control	12
Antenna connections	14
Cable TV connections.....	14

TV operation

Starting setup	15
TV operation	16
Quick guide for menu operation	18
Convenience functions	19
Channels setup.....	23
Labeling Channels	24
Setting the Parental Control	25
Closed Caption	28
CC options.....	29
Aspect Switching	30
JPEG Viewer.....	31

Additional information

Connections to other equipment.....	32
Reception disturbances	34
Troubleshooting	35
Specifications	37
LIMITED WARRANTY	39

Features

HDTV

Unique space saving design in a 48" class TV.

Picture Performance



- Long Life LED Backlight
- 2160p Perfected
- Super Clear Anti-Glare Screen

Convenience

- HDMI ver 2.0 inputs
- USB Input (JPEG Photo Viewer, Software Updates)
- Sleep Timer (5-240 min)

Audio Performance

- Dolby® Digital
- MTS Stereo/SAP

This Television receiver will display television closed captioning, ( or ), in accordance with FCC rules.

* The terms HDMI and HDMI High-Definition Multimedia Interface, and the HDMI Logo are trademarks or registered trademarks of HDMI Licensing LLC in the United States and other countries.

* Manufactured under license from Dolby Laboratories. Dolby, Dolby Audio and the double-D symbol are trademarks of Dolby Laboratories.

Location of controls

Front

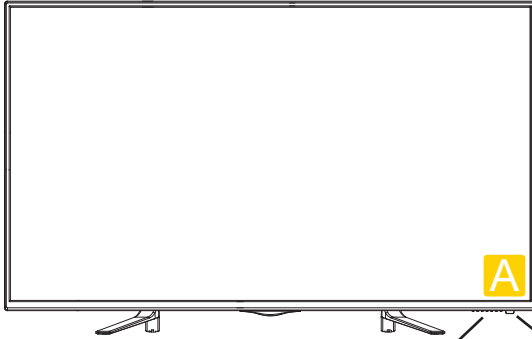

A

Control Key



MENU button, **CH (CHANNEL) ▼/▲** (▼/▲) buttons, **VOL (VOLUME) -/+** (◀/▶) buttons and **INPUT(SELECT)** button can be used to select the desired setting during the menu screen operations.

Control Keys

Remote sensor
Power Indicator
Red : Standby

Rear

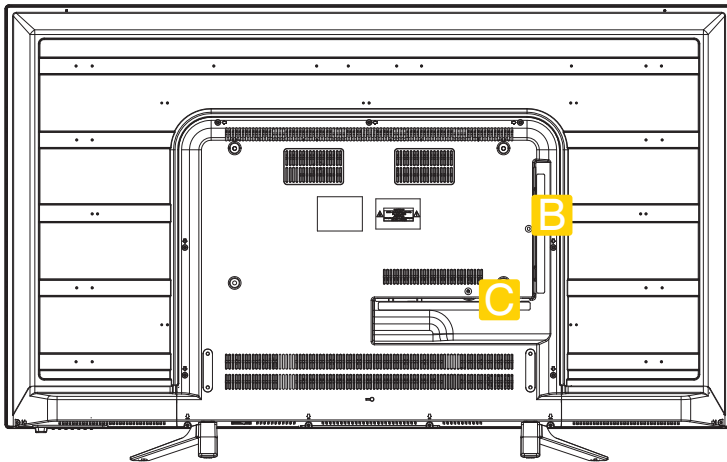

B

Left side

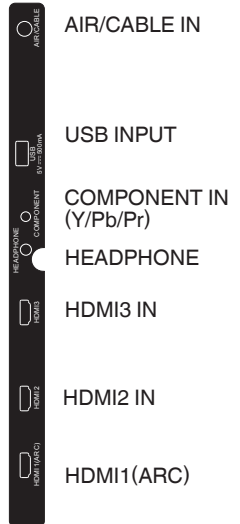

C

Bottom side



AC IN

VIDEO IN

Remote control



POWER Button - Press to turn the TV's power on/off.

INPUT Button - Press to change the TV's input.

COLOR Buttons - Available for use in the Channel List and Program Guide. The OSD will display guidance for these buttons when they are available.

HDMI1 Button - Press to directly access the HDMI1 input.

HDMI2 Button - Press to directly access the HDMI2 input.

HDMI3 Button - Press to directly access the HDMI3 input.

COMP Button - Press to directly access the Component input.

ASPECT Button - Press to change the picture size.

C.C. Button - Use to select Closed Caption to "CC Off", "CC On" or "CC with Mute".

AUDIO Button - Press to change the audio language.

SLEEP Button - To set the TV to turn off automatically after a preset amount of time.

GUIDE Button - Press to display the program guide for DTV channels.

INFO Button - When you press this button the current information will be displayed on the screen.

S.MODE Button - Press to change the sound mode.

P.MODE Button - Press to change the picture mode.

MENU Button - Use to display the On-Screen menu function.

CH LIST Button - Press to display the Channel List.

SELECT Button - Press to enter or select functions for the On-Screen menu.

CURSOR \blacktriangle / \blacktriangledown / \blacktriangleleft / \blacktriangleright Buttons - Use to navigate and select menu functions of the TV.

EXIT Button - Press to exit the On-Screen menu.

FAV CH Button - Press to access the Favorite Channel list.

VOL (VOLUME) + / - Buttons - Press the + button to increase, or the - button to decrease the sound level.

LAST CH Button - Pressing this button allow you to go back to the previous channel selected. Press this button again to return to the channel you were watching.

MUTE Button - To turn off the sound, press this button once. The TV will be silenced and the MUTE icon will appear on the screen. The muting feature can be released by pressing the **MUTE** button again or one of the **VOL (VOLUME) +** buttons.

CH (CHANNEL) \wedge / \vee Buttons - Press to change the channel of the TV.

Direct Channel Selection Buttons (0-9) - Allows direct access to any channel of the TV.

- Button - This button is the "-" button and is used when selecting digital channels.

ENTER Button - Press to enter or select functions for the On-Screen menu.

HOW TO INSTALL BATTERIES

1. Open the battery compartment cover.
2. Install two “AAA” batteries (supplied).

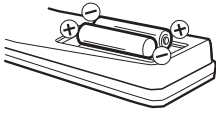

3. Replace the battery compartment cover

BATTERY PRECAUTIONS

These precautions should be followed when using batteries in this device:

- The batteries may last approximately one year depending on how much the remote control is used. Replace batteries when the remote operation becomes erratic.
- Use only the size and type of batteries specified.
- Be sure to follow the correct polarity when installing the batteries as indicated in the battery compartment. Reversed batteries may cause damage to the device.
- Do not mix different types of batteries together (e.g. Alkaline, Carbon-zinc or Rechargeable) or old batteries with fresh ones.
- If the device is not to be used for a long period of time, remove the batteries to prevent damage or injury from possible battery leakage.
- Do not try to recharge batteries not intended to be recharged; they can overheat and rupture. (Follow battery manufacturer's directions.)
- Please use caution when inserting batteries to avoid battery damage. If the spring terminal in the remote control remains in contact with a side of a damaged battery it can cause a short circuit. Never use damaged batteries as they can become very hot and are dangerous.
- Never expose batteries (battery pack or batteries installed) to excessive heat such as sunshine, fire or the like.

Antenna connections

If you are using an indoor or outdoor antenna, follow the instructions below that correspond to your antenna system. If you are using a Cable TV service, see Cable TV connections.

Combination VHF/UHF Antenna (Single 75 ohm cable)

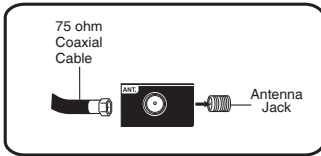

Connect the 75 ohm cable from the combination VHF/UHF antenna to the Antenna Jack.

Cable TV connections

This TV has an extended tuning range and can tune most cable channels without using a Cable TV Converter box. Some cable companies offer “premium pay channels” where the signal is scrambled. Descrambling these signals for normal viewing requires the use of a descrambler device which is generally provided by the Cable TV company.

For subscribers to basic Cable TV service

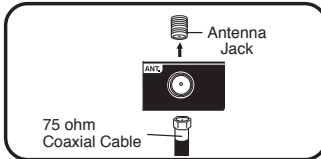

For basic Cable TV service not requiring a Converter/Descrambler box, connect the 75 ohm Coaxial Cable directly to the Antenna Jack on the back of the TV.

For subscribers to scrambled Cable TV service

If you subscribe to a Cable TV service which requires the use of a Converter/Descrambler box, connect the incoming 75 ohm Coaxial Cable to the Converter/Descrambler box. Using another 75 ohm Coaxial Cable, connect the output jack of the Converter/Descrambler box to the Antenna Jack on the TV. Follow the connections shown below. Set the TV to the output channel of the Converter/Descrambler box (usually channel 3 or 4) and use the Converter/Descrambler box to select channels.

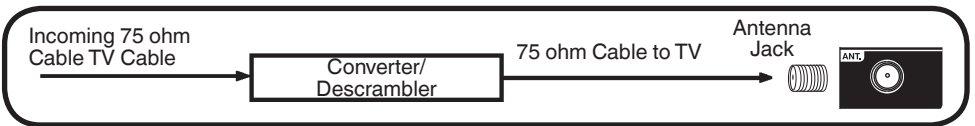

For subscribers to unscrambled Cable TV service with scrambled premium channels

If you subscribe to a Cable TV service in which basic channels are unscrambled and premium channels require the use of a Converter/Descrambler box, you may wish to use a signal Splitter and an A/B Switch box (available from the Cable TV company or an electronics supply store). Follow the connections shown below. With the switch in the “B” position, you can directly tune any non-scrambled channels on your TV. With the switch in the “A” position, tune your TV to the output of the Converter/Descrambler box (usually channel 3 or 4) and use the Converter/Descrambler box to tune scrambled channels.

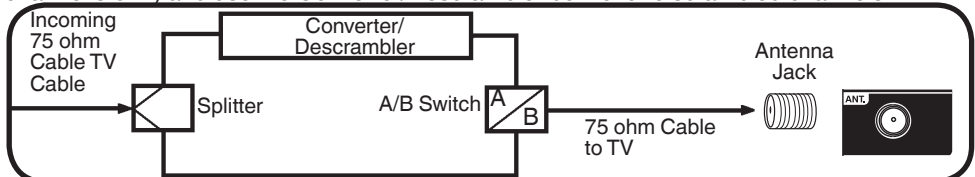

Starting setup

The Setup Wizard appears the first time you turn on the TV, and assists you to specify the Air/Cable setting, and program your channels automatically.

IMPORTANT: Make sure that the antenna or cable TV system connection is made.

- 1 To turn on the TV, press **POWER**. (It may take approx. 10 seconds for a picture to appear on screen.) The Initial Setup Wizard begins.

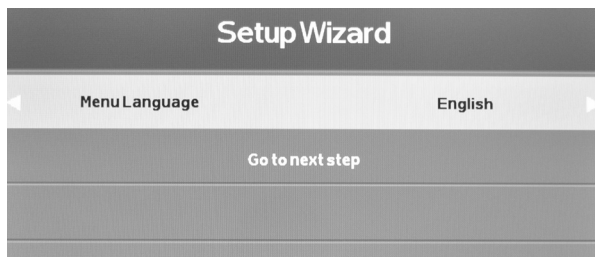

- 2 Press ◀ or ▶ to select your menu language, then press ▼ or **SELECT**. Press ▶ or **SELECT** to go to the next step.
- 3 Press ◀ or ▶ to select your time zone, then press ▼ or **SELECT**.
 - In the rare event that you live within broadcast range of two stations in two different time zones, the TV may recognize the wrong station for the auto clock set.
- 4 Press ◀ or ▶ to select daylight saving time on or off, then press ▼ or **SELECT**.
- 5 Press ◀ or ▶ to your desired time format, then press ▼ or **SELECT**. Press ▶ or **SELECT** to go to the next step.
- 6 Press ◀ or ▶ to select the signal type that you using, then press ▼ or **SELECT**. Press ▶ or **SELECT** to go to the next step.
- 7 Auto Channel Scan will begin. After the scan is completed, a TV channel appears on the screen.
 - Depending on the reception condition, it may take up to 30 minutes to complete scanning channels. Please allow the process to complete without interruption.
 - You can exit without the channel scan if you are using a Cable or Satellite Box connecting to HDMI inputs.

NOTE:

- If you press **EXIT** during the "Auto Channel Scan" process, the Auto Channel Scan will stop and the TV will change to the normal view.
- When you make a menu selection, your changes occur immediately. You do not have to press **EXIT** to see your changes.

TV operation

- 1 To turn on the TV, press **POWER**. (POWER indicator on the front of the unit changes blue. It may take approx.10 seconds for a picture to appear on screen.)
- 2 Adjust the volume level by pressing **VOL (VOLUME) +** or **-** . The volume level will be indicated on the screen by a volume bar. If the volume increases, the number of bars also increases. If the volume decreases, the number of bars also decreases.
- 3 Set the Source option to the appropriate selection (see “Air/Cable selection” on page 23).
- 4 Press the **Direct Channel Selection Buttons (0-9, -)** to select the channel.

TO SELECT ANALOG CHANNELS

- 1-9: Press **1-9** as needed.
Example, to select channel 2, press **2**, then press **SELECT**.
- 10-99: Press the 2 digits in order.
Example, to select channel 12, press **1, 2**, then press **SELECT**.
- 100-135: Press the 3 digits in order.
Example, to select channel 120, press **1, 2, 0**, then press **SELECT**.

TO SELECT DIGITAL CHANNELS

Press the first digits, then press the **-** button followed by the remaining number.

Example: To select channel 15-1, press **1, 5, -, 1**, then press **SELECT**.

- If a channel is selected with only audio content, “Audio Only” will be displayed on the screen.
- If a channel is selected with a weak digital signal, “No Signal” will be displayed on the screen.
- To direct tune to a digital channel that is not stored in the channel list enter the first digits followed by **-** and press **SELECT**. For example if you want to select channel 15-2, press **1, 5, -** then press **SELECT**.
- The same program may be available on either an analog channel or a digital channel. You may choose to watch either format.

VHF/UHF/CABLE CHANNELS

Air	Cable
VHF 2-13	VHF 2-13
UHF 14-69	STD/HRC/IRC 14-36 (A) (W) 37-59 (AA) (WW) 60-85 (AAA) (ZZZ) 86-94 (86) (94) 95-99 (A-5) (A-1) 100-135 (100) (135) 01 (4A)

NOTE:

- If a channel with no broadcast is selected, the sound will automatically be muted.
- It may take a few seconds for a digital channel picture to appear on screen after being selected.
- To direct tune to a digital channel that is not stored in the channel list enter the first digits followed by **-** and press **SELECT**. For example if you want to select channel 15-2, press **1, 5, -** then press **SELECT**.

TV operation

(continued)

To select the Audio/Video input source

To view a signal from another device connected to your TV, such as a Blu-ray player, press **INPUT**, then press ▲ or ▼ to select the desired input, then press **SELECT**.

CH ^/▼

Press and release **CH ^/▼**. The TV automatically stops at the next channel.

For proper operation, before selecting channels, they should be set into the memory. See “Channels setup” on page 23.

INFO

Press **INFO** to display the current information on the screen.

When the TV receives a digital signal, the digital information will appear.



- Channel number
- Channel label (if preset)
- Parental Control
- Program guide
- Resolution
- DTV Signal condition
- Broadcast program name
- Signal Type
- Current date and time
- Audio language

Press **INFO** again to clear the display.

LAST CH

This button allows you to go back to the last channel selected by pressing **LAST CH**. Press **LAST CH** again to return to the channel you were watching.

MUTE

Press **MUTE** to switch off the sound. The TV's sound will be silenced and MUTE icon will appear on the screen. The sound can be switched back on by pressing this button again or by pressing the **VOL (VOLUME) +** button.

Quick guide for menu operation

Example: Select Menu Language.

- 1 Press **INPUT** to select TV mode.
- 2 Press **MENU**. The TV menu screen will appear.

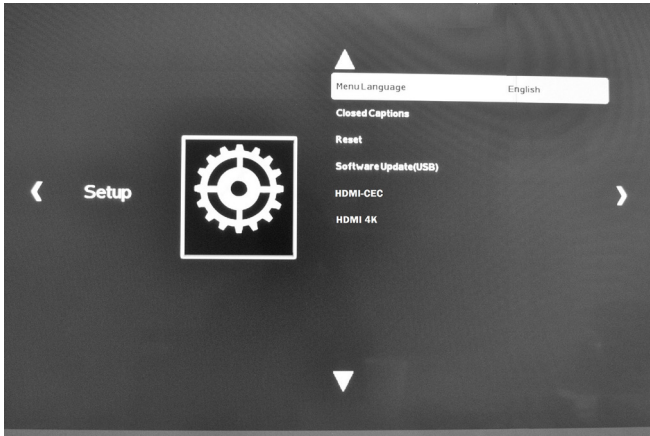

- 3 Press ◀ or ▶ to select “Setup”, then press ▼.
- 4 Press ▲ or ▼ to select “Menu Language”, then press **SELECT** and select the desired language.
- 5 Press **EXIT** to return to the normal screen.

NOTE:

- On the following pages, the menu can be called in the same way described above, by pressing the **MENU** button.
- If no buttons are pressed for more than about 30 seconds, the TV will return to normal viewing automatically.
- During TV or external input mode, if there is no signal reception or external device is disconnected, the TV will automatically go to standby mode after approx. 15 minutes.

Convenience functions

You can change the default settings by pressing the **MENU** button on your remote, then select one of the icons at the top of the menu - follow the On-Screen prompts to set your preferences.

Icon	Selected Items	Setup Hint
Video	Picture Mode	
	Standard	Standard picture quality.
	Dynamic	Bright and dynamic picture.
	Movie	Soft edge picture setting.
	ECO	Reduced brightness, saves energy.
	Custom	Your personal preferences.
	Contrast	You can adjust the picture quality to your preference.
	Brightness	
	Sharpness	
	Tint	
	Color	
	Color Temperature	Cool (Bluish) / Standard (Neutral) / Warm (Reddish)
Aspect Ratio	See page 30.	
Noise Reduction	Set the level of decreasing noise included in the video signal.	
Off / Low / Medium / High		

Convenience functions

(continued)

Icon	Selected Items	Setup hint
Audio	Sound Mode	
	Standard / Music / Movie / Sports	You can choose a basic equalizer mode. Depending on this setting, the EQ settings are set to the pre-defined values of each mode.
	Custom	The setting of this item adjusts the audio level.
	Bass / Treble / Balance	
	MTS	The multi-channel TV sound (MTS) feature provides high-fidelity stereo sound. MTS also can transmit a second audio program (SAP) containing a second language or other audio information. This item is valid only when the analog broadcast.
	Stereo / SAP / Mono	
	Audio Language	When two or more audio languages are included in a digital signal, you can select one of the audio languages. (This function is available only for digital broadcasts.)
	English / French / Spanish	
	Digital Output	Select the format for your digital audio output If you have connected an amplifier / receiver to the digital audio jack on your TV.
	Raw / PCM	
Surround Sound	The dynamic presence and sound created offers a thoroughly enjoyable listening experience.	
Off / On		
Perfect Volume	Volume level is adjusted automatically to lower volume of loud scenes and to raise volume of quieter scenes.	
Off / On		

Convenience functions

(continued)

Icon	Selected Items	Setup hint
Time	Sleep Timer Off / 5 / 10 / 15 / 30 / 60 / 90 / 120 / 180 / 240 min/ Custom	Sleep Timer switches the TV to standby after a defined period of time. To cancel the Sleep Timer, set to "Off".
	Time Zone	Select your local time zone for auto clock feature. You can select Pacific, Alaska, Hawaii, Atlantic, Eastern, Central, and Mountain.
	Daylight Savings Off / On	If you want to activate Daylight Saving Time, select "On".
	Time Format 12-hour / 24-hour	Select the time format.
	Time Mode Manual / Auto	The Auto Clock function will automatically set the built-in clock (Year, Month, Day and Time) when the TV is connected to an antenna or cable TV system and it is turned off. As the TV searches for a receivable station in your area and it receives a broadcast signal for Auto Clock, the Auto Clock needs several minutes to set itself.
	Time	Use the ▲/▼/◀/▶ buttons to set the clock. <ul style="list-style-type: none"> • Available only when you selected "Time Mode" to "Manual".

Convenience functions

(continued)

Icon	Selected Items	Setup hint
Setup	Menu Language	You can choose from three different languages (English, Français (French) and Español (Spanish)) for the on-screen displays. Select the language you prefer first, then proceed with the other menu options.
	English / French / Spanish	
	Closed Captions	See page 28.
	Reset	Restore Video, Audio, Time and Setup settings to the default factory settings.
	No / Yes	
	Software Update (USB)	Update the software.
	HDMI - CEC	
	CEC Enable	Select "On" to enable CEC features.
	ARC	To enable the audio through an AV receiver using HDMI (ARC).
	Device Auto Power Off	When the user turns off the TV, all active CEC enabled devices on the HDMI input will go to Standby.
	TV Auto Power On	Pushing the "Play" button on the CEC enabled device will command the device to play, turn the TV on, and the HDMI input, that the device is connected to, will become the active input device for the TV.
	Device Lists	Display devices that are connected to TV.
	HDMI4K	
	Standard / Enhancement	Select the HDMI4K mode. Use "Standard" if your 4K device supports HDMI 1.4, use "Enhancement" if your 4K device supports HDMI 2.0.
Lock	See page 25.	
Channels	See page 23. (Only accessible in the TV input).	

Channels setup

This TV is equipped with a Channel List feature which allows channels to skip up or down to the next channel set into the Channel List, skipping over unwanted channels.

Before selecting channels, they must be scanned into the TV's Channel List.

Air/Cable selection

- 1 Select "Channels" ⇒ "Source".
- 2 Press ◀ or ▶ to select "Air" or "Cable".

Air - VHF/UHF channels
Cable - CABLE TV channels

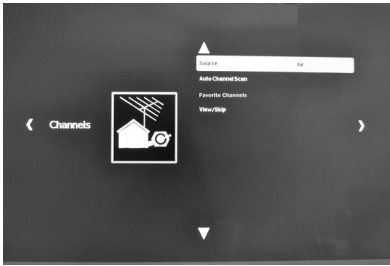

NOTE:

- It may take a few seconds for a digital channel picture to appear on screen after being selected.

Auto Channel Scan

- 1 Select "Channels" ⇒ "Auto Channel Scan", then press **SELECT**.

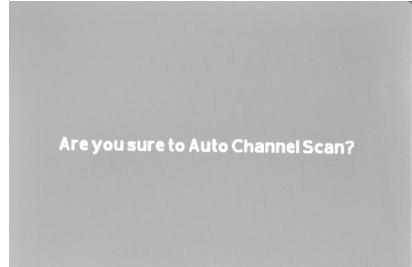

- 2 In the confirmation window, press ▶ to select "Yes". The TV will begin scanning all the channels available in your area.
 - It may take from 15 minutes to 30 minutes to complete channel scan.
 - Depending on the reception condition the progress bar may not advance for several minutes, please be patient.
 - If you press **EXIT** while scanning, the channel scan will stop.

NOTE:

- If you are unsure of the digital channels available in your area, you may visit www.antennaweb.org to receive a list based on your address or zip code. If you require further assistance you may call our toll-free customer service line at 800.HITACHI (800.448.2244) (USA/CANADA).
- New channels may be added to your area periodically, it is recommended to perform the "Auto Channel Scan" procedure regularly.

- 3 The new channels will be added into the channel list.

Channel Manager

You can select the channel that you want to add to favorite.

- 1 Select “Channels” ⇒ “Favorite Channels”, then press **SELECT**.
- 2 Press ▲ or ▼ to select the channel that you want to add.

Favorite		
6-1	XETV-HD	✓
6-2	XHGC-HD	✓
12-1	XEWT	✓
15-1	KPBS-HD	
15-2	V-Me	

- 3 Press **SELECT** to assign ✓ mark for wanted channel.
- 4 Repeat steps 2 - 3 for other channels you want for Favorite.

You can also select the channel that you want to skip.

- 1 Select “Channels” ⇒ “View/Skip”, then press **SELECT**.
- 2 Press ▲ or ▼ to select the channel that you want to skip.

View/Skip		
6-1	XETV-HD	✓
6-2	XHGC-HD	✓
12-1	XEWT	✓
15-1	KPBS-HD	
15-2	V-Me	

- 3 Press **SELECT** to assign ✓ mark for unwanted channel.
- 4 Repeat steps 2 - 3 for other channels you want to skip.

Labeling channels

Channel labels appear with the channel number display each time you turn on the TV, select a channel, or press **DISPLAY**. You can choose any 7 characters to identify a channel.

To create channel labels

- 1 Press **CH LIST** on the remote control.
- 2 Press ▲ or ▼ to select a channel you want to label, then press **YELLOW** on the remote control. An on screen keyboard will be displayed.

ChannelList		
15-1	KPBS-HD	DTV
15-2	V-Me	DTV
17-1	KBNT-DT	DTV
17-2	LATV	DTV
21-1	UNKNOWN	DTV
27-1	XH-1K-TD	DTV

- 3 Using the remote control and the on screen keyboard enter your channel label.



- 4 After entering your channel label press **CH LIST** to return to the Channel List.
- 5 Repeat steps 2 - 4 for other channels. You can assign a label to each channel.
- 6 When you finish inputting the label name, press **EXIT** to return to normal viewing.

NOTE:

- The channel labels will reset after “Auto Channel Scan” on page 23.

Setting the Parental Control

An age limitation can be set to restrict children from viewing or hearing violent scenes or pictures that you may choose to exclude. The restriction applies to “US” TV/ Movie Ratings and “Canada” English/French Ratings if this data is transmitted. You may set this restriction separately. To use the Parental Control function, you must register a password.

To enter a password

- 1 Select “Lock”, then press ▼.
- 2 Press **0000** using **Direct Channel Selection Buttons (0-9)**. (This is default password.)

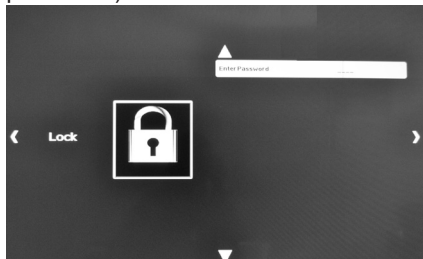

“*” appears instead of the number.

NOTE:

- If you forget your password, use the factory password **7777**, you can then gain access to change your password if necessary.
- To avoid forgetting the password, write it down and keep in a safe place.

How to enter the Parental Control menu

- 1 Select “Lock” menu, then press ▼.
- 2 Use **Direct Channel Selection Buttons (0-9)** to enter your password.

To set the Parental Control

- 1 In the Lock menu, press ▲ or ▼ to select “Parental Control” then press **SELECT** to set to “On”.
- 2 Press ▲ or ▼ to select “US Rating”, then press **SELECT**.
- 3 Press ▲ or ▼ to select “TV” or “Movie” and press **SELECT**.
- 4 Press ▲ or ▼ to select which rating will be used, then press ◀/▶ or **SELECT**. Each rating below will appear.

TV



You can set the rating using age level and genre.

Age:

- TV-Y** : All children
- TV-Y7** : 7 years old and above
- TV-G** : General audience
- TV-PG** : Parental guidance
- TV-14** : 14 years old and above
- TV-MA** : 17 years old and above

Genre:

- FV** : Fantasy Violence
- D** : Dialogue
- L** : Language
- S** : Sex
- V** : Violence

Press ▲ or ▼ to select the desired rating, then press **SELECT**.

Movie:

- G** : All ages
- PG** : Parental guidance
- PG-13** : Parental guidance less than 13 years old
- R** : Under 17 years old parental guidance suggested
- NC-17** : 17 years old and above
- X** : Adult only

Press ◀ or ▶ to select the desired rating.

- 4 Press **EXIT** to return to normal viewing. Parental Control function is activated now.

Canadian rating systems

- 1 In the Locks menu, press ▲ or ▼ to select “Parental Control” then press **SELECT** to set to “On”.
- 2 Press ▲ or ▼ to select “Canada Rating”, then press **SELECT**.
- 3 Press ▲ or ▼ to select “English” or “French”, then press ▲ or ▼ to select desired rating.



Canada English ratings

You can set the rating using age.

- C** : Programming intended for children under age 8
- C8+** : Programming generally considered acceptable for children 8 years and over to watch on their own
- G** : General Audience
- PG** : Parental Guidance
- 14+** : Programming contains themes or content which may not be suitable for viewers under the age of 14
- 18+** : Adult

Canada French ratings

- G** : General: All ages and children, contains minimal direct violence, but may be integrated into the plot in a humorous or unrealistic manner.
- 8ans+** : General but inadvisable for young children: May be viewed by a wide public audience, but could contain scenes disturbing to children under 8 who cannot distinguish between imaginary and real situations. Recommended for viewing with parent.
- 13ans+** : Over 13 years: Could contain scenes of frequent violent scenes and therefore recommended for viewing with parent.
- 16ans+** : Over 16 years: Could contain frequent violent scenes and intense violence.

18ans+ : Over 18 years. Only for adult viewing. Could contain frequent violent scenes and extreme violence.

4 Press **EXIT** to return to normal viewing. Parental Control function is activated now.

NOTE:

- The Parental Control function is activated only on programs and input sources that include a rating signal.

To change the password

1 In the Locks menu, press **▲** or **▼** to select “Change Password”, then press **SELECT**.

2 Enter your old password using **Direct Channel Selection Buttons (0-9)**.

3 Enter your new password using **Direct Channel Selection Buttons (0-9)**.

4 Enter the new password again to confirm. Your new password is now registered.

Downloading the additional Parental Control rating system (Region 5)

As a supplement to the standard Parental Control rating system, your television is able to download an additional rating system, if such a system becomes available in the future.

To download the additional Parental Control rating system (when available)

1 In the Locks menu, press **▲** or **▼** to select “Parental Control” then press **SELECT** to set to “On”.

2 Press **▲** or **▼** to select “Region 5”, then press **SELECT**.

3 If the TV is not storing the additional rating system, the TV will begin downloading it, which may take some time to be completed.

4 Set your preferred content rating limits for the additional rating system.

NOTE:

- The TV can download an additional rating system only when receiving a digital signal that carries the Region 5 rating information.

- When you download the additional rating system, it may take some time for the download to occur.
- The Parental Control rating information and system are not determined or controlled by the TV.
- The standard Parental Control rating system is available whether your TV is receiving a digital signal or not, and will block both analog and digital programs.
- To set the restriction level using the standard Parental Control rating system, select “US” in step 2.
- The downloadable Parental Control rating system is an evolving technology, and availability, content, and format may vary.

To clear the Region 5

1 In the Locks menu, press **▲** or **▼** to select “Parental Control” then press **SELECT** to set to “On”.

2 Press **▲** or **▼** to select “Reset Region 5”, **SELECT**. The confirmation window will appear.

3 Press **▶** to select “Yes”, then press **SELECT**. Your Region 5 will clear.

Closed Caption

WHAT IS CLOSED CAPTIONING?

This television has the capability to decode and display Closed Captioned television programs. Closed Captioning will display text on the screen for hearing impaired viewers.

Captions: This Closed Caption mode will display text on the screen in English or another language. Generally, Closed Captions in English are transmitted on CC1 and Closed Captions in other languages are transmitted on CC2.

Text: The Text Closed Caption mode will usually fill 1/2 of the screen with a programming schedule or other information.

- 1 Select "Setup" ⇒ "Closed Captions", then press **SELECT**.
- 2 Press ◀ or ▶ to set "Caption Display", to "CC On", "CC on Mute", or "CC Off".
CC On: Captions will be displayed on the screen.
CC on Mute: Only when you press **MUTE**, captions will be displayed.
CC Off: Captions will not be displayed on the screen.
- 3 Press ▲ or ▼ to select "Analog Captions" or "Digital Captions".
When you select "Analog Captions", you can choose from CC1~4, Text1~4.
When you select "Digital Captions", you can choose from Service1~6 and Off.
- 4 Press ◀ or ▶ to select the desired Closed Caption mode for both Digital and Analog Captions.

NOTE:

- Depending on the broadcast signal, some Analog Captions will function with a Digital broadcast signal. This prevents two types of captions from overlapping.
- If text is not available in your viewing area, a black rectangle may appear on-screen. If this happens, set the CC Setting to "CC Off".
- When selecting Closed Captions, the captioning will appear after approx. 10 seconds.
- Misspellings or unusual characters may occasionally appear during Closed Captioning.
This is normal with Closed Captioning, especially with live programs. This is because during live programs, captions are also entered live. These transmissions do not allow time for editing.
- When Captions are being displayed, on-screen displays, such as volume may be seen but may interfere with Closed Captions.
- Some cable systems and copy protection systems may interfere with the Closed Captioned signal.
- If using an indoor antenna or if TV reception is very poor, the closed caption may not appear or may appear with strange characters or misspelled words. In this case, adjust the antenna for better reception or use an outdoor antenna.

CC options

When you have selected “Custom” as the display method, you can adjust the various setting listed below.

This feature is designed to customize Digital Caption only.

- 1 Select “Setup” ⇒ “Closed Captions”, then press **SELECT**.
- 2 Press ◀ or ▶ to set “Caption Display” to “CC Off”, “CC On” or “CC on Mute”.
- 3 Select “Digital CC Options”, then press **SELECT**.
- 4 Press ◀ or ▶ to set the “Caption Style” to “Custom”.
- 5 Press ▲ or ▼ to select the desired item, then press ◀ or ▶ to change the setting.

Caption Style	Custom
Font	Default
Size	Default
Edge Effect	Default
Edge Color	Default
Text Color	Default

You can select from among the following items and parameters.

Font:

Select display font style.

Size:

Select display font size.

Edge Effect:

Select display font edge style.

Edge Color:

Select display font edge color.

Text Color:

Select foreground color.

Background Color:

Select background color.

Text Opacity:

Select foreground opacity level.

Background Opacity:

Select background opacity level.

NOTE:

- You cannot set both “Text Color” and “Background Color” as the same color.

Aspect Switching

You can change the picture size being displayed — Normal, Wide, Auto mode.



Selecting the picture size

1 Press **ASPECT** on the remote control.

2 Repeatedly press **ASPECT** to select the desired aspect ratio, as described below.

NOTE:

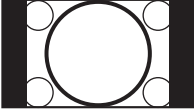
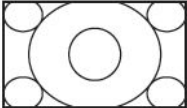
- Selectable aspect ratios may vary depending on the input source or broadcast signal.

<p>Normal In some cases, the image will display the size of standard 4:3 with black side bars.</p>	
<p>Wide Displays the picture at the maximum size.</p>	
<p>Auto Displays the picture in it's original format.</p>	

JPEG Viewer

You can enjoy viewing pictures from your **USB storage device**.

- 1 Connect the USB storage device into the USB Input terminal.
- 2 Press **INPUT** and press **▲** or **▼** to select “USB”, then press **SELECT**.

NOTE:

- Do not disconnect a USB storage device while it is being accessed. Doing so can damage the device or the files stored on the device. You can safely connect or disconnect the USB storage device when the TV is not in USB mode.
- Back up all the data in the USB storage device in case if data was lost due to unexpected accident. We do not assume any liability for the losses by misuse or malfunction.
- Not all USB storage devices are compatible with this TV.
- The character that exceeds the display area is not displayed.
- Do not use a USB extension cable.
- Playable files are JPEG (.jpg/.jpeg).

USB Browser

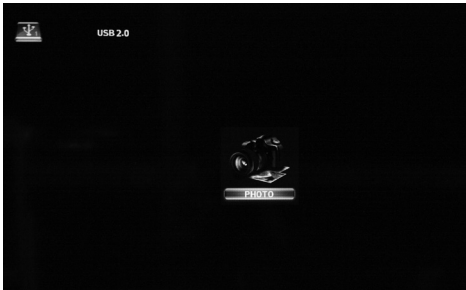

File Selection



NOTE:

- The content will change in accordance with each media setting screen

Playback files

- 1 Press **SELECT** to select Photo.
- 2 Press **SELECT** to select “C”.
- 3 Select a folder or file using the **▲/▼/◀/▶** buttons and then start photo viewing by pressing the **SELECT** button.

Connections to other equipment

To connect the TV to a HDMI device to the TV

The HDMI input receives digital audio and video from an HDMI device.

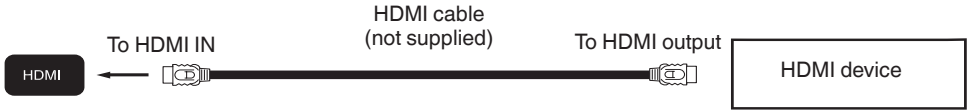

NOTE:

- HDMI input audio does not support DTS audio.

The exact arrangement you use to interconnect various video and audio components to this TV is dependent on the model and features of each equipment. Check the Owner's Manual provided with each component for the location of video and audio inputs and outputs.

To connect the TV to a VCR, a camcorder, or a game console

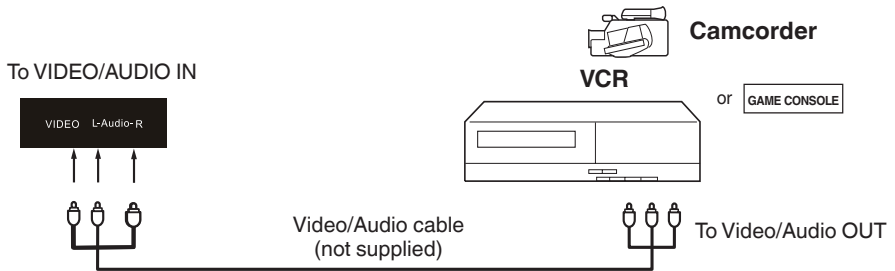

To connect the TV to a DVD player with Component Video Input

You can enjoy a high quality picture by connecting the unit's COMPONENT VIDEO OUT jacks of your DVD player with the component video cables (not supplied).

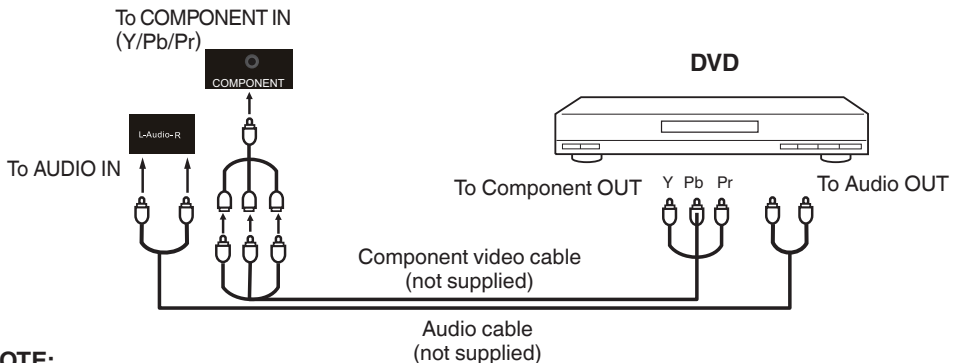

NOTE:

- The Component Video input of this TV is compatible with 480i/1080i interlaced signals and 480p/720p progressive signals.

Connections to other equipment

(continued)

Using an AV Amplifier with built-in digital surround

If you are using an AV Amplifier with built-in digital surround sound, you can enjoy broadcast or cable programs that provide Dolby Digital sound.

Connect an AV amplifier with built-in Dolby Digital decoder, etc. as shown below.

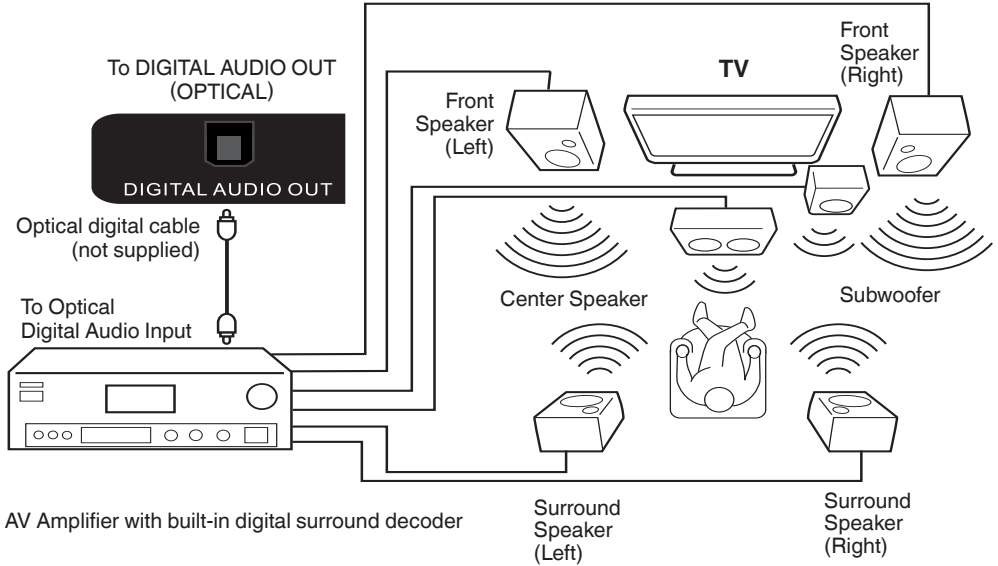

Reception disturbances



IGNITION NOISE:

Black spots or horizontal streaks may appear, picture may flutter or drift. Usually caused by interference from automobile ignition systems, neon lamps, electrical drills, and other electrical appliances.



GHOSTS:

Ghosts are caused by the television signal following two paths. One is the direct path and the other is reflected from tall buildings, hills or some other objects. Changing the direction or position of the antenna may improve reception. Ghosting may also be caused by defects in the antenna system such as unshielded leads or connecting several sets to the same antenna without using multiple antenna couplers.



SNOW:

If your receiver is located in the fringe area of a television station where the signal is weak, your picture may be marred by the appearance of small dots. When the signal is extremely weak, it may be necessary to install a special antenna to improve the picture.

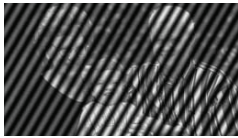

RADIO FREQUENCY INTERFERENCE:

The interference produces moving ripples or diagonal streaks, and in some cases, causes loss of contrast in the picture.

PREVENTION OF AN OBSTACLE TO RADIO RECEIVERS

This television has been designed pursuant to the FCC class B Rules. This is to prevent a problem to Radio receivers. If this television causes a problem to Radio receivers, then take the following steps:

- Keep the television away from Radio.
- Adjust Radio antennas in order for the television not to receive interference.
- The antenna cable of Radio should be kept away from the television.
- Use a coaxial cable for antenna.

You can check if this television influences Radio receivers by turning off all other equipment other than the television. If you find a problem receiving Radio when using the television, check the instructions mentioned above.



BLOCK NOISE or FREEZE (DIGITAL INPUT):

Fuzzy blocks may appear in some area or the whole area of the screen. This is usually caused by interference from automobile ignition systems, neon lamps, electrical drills, ghosting of the image and lost or weak receiving signals.

NOTE:

- The TV set can generate sound distortion in external devices such as a radio. Please separate radio equipment from the TV set to a considerable distance.

Troubleshooting

Use the following checklist for troubleshooting if you have problems with your TV. Consult your local dealer or service outlet if problems persist. Be sure all connections are properly made when using with other units.

SYMPTOMS	POSSIBLE SOLUTIONS
TV does not operate.	<ul style="list-style-type: none">• Make sure the power cord is plugged in.• Try another AC outlet.• Power is off, check fuse or circuit breaker.• Unplug unit for an hour, then plug it back in.
Poor sound or no sound.	<ul style="list-style-type: none">• Station or Cable TV experiencing problems, tune to another station.• Check sound adjustments (Volume or Mute).• Check for sources of possible interference.• Check for audio language setting.
Poor picture or no picture.	<ul style="list-style-type: none">• Station or Cable TV experiencing problems, tune to another station.• Make sure channels are set into memory.• Check antenna or Cable TV connections, adjust antenna.• Check for sources of possible interference.• Check picture control adjustments.
Poor reception on some channels.	<ul style="list-style-type: none">• Station or Cable TV experiencing problems, tune to another station.• Make sure channels are set into memory.• Station is weak, adjust antenna to receive desired station.• Check for sources of possible interference.
Poor color or no color.	<ul style="list-style-type: none">• Station or Cable TV experiencing problems, tune to another station.• Make sure channels are set into memory.• Check picture control adjustments.• Check antenna or Cable TV connections, adjust antenna.• Check for sources of possible interference.
Picture wobbles or drifts.	<ul style="list-style-type: none">• Station or Cable TV experiencing problems, tune to another station.• Make sure channels are set into memory.• Cable TV company is scrambling signal.• Adjust antenna.
Digital broadcasting screen problem.	<ul style="list-style-type: none">• Check digital signal strength.

If the problem cannot be solved with the suggested procedures, contact
800.HITACHI.

For your safety, never try to repair the product yourself.

SYMPTOMS	POSSIBLE SOLUTIONS
No CATV reception.	<ul style="list-style-type: none"> • Check all Cable TV connections. • Set Source menu option to the Cable mode. • Station or Cable TV system problems, try another station.
Horizontal or diagonal bars on screen.	<ul style="list-style-type: none"> • Check antenna connections, adjust or re-direct antenna. • Check for sources of possible interference.
No reception above channel 13.	<ul style="list-style-type: none"> • Make sure the appropriate Source (Air or Cable) has been selected. • If using antenna, check UHF antenna connections.
No Remote operation.	<ul style="list-style-type: none"> • Batteries are weak, dead or inserted incorrectly. • Remote is out of range, move closer to TV (within 15 feet). • Make sure Remote is aimed at sensor. • Confirm there are no obstructions between the Remote and the TV. • Make sure the power cord is plugged in.
TV shuts off.	<ul style="list-style-type: none"> • Sleep Timer is set. • Power interrupted. • Auto TV Off is set.
Closed Caption is not activated.	<ul style="list-style-type: none"> • TV station experiencing problems or program tuned is not closed captioned. Try another channel. • Check Cable TV connection or VHF/UHF antenna, reposition or rotate antenna. • Set Closed Caption Decoder in the menu.
TV is not shown in your language.	<ul style="list-style-type: none"> • Select proper language in the menu options.

Specifications

Model	48C6	
Panel size	48" class 47.61" diagonal (1209.4mm)	
Display method	Transmission TFT color LCD panel	
Number of Pixels	3840(H) × 2160(V)	
Broadcasting system	US system M ATSC standard (8VSB), QAM	
Receiving channels	VHF 2-13 UHF 14-69 CATV 14-36 (A)-(W) 37-59 (AA)-(WW) 60-85 (AAA)-(ZZZ) 86-94 (86)-(94) 95-99 (A-5)-(A-1) 100-135 (100)-(135) 01 (4A)	<ul style="list-style-type: none"> • Digital Terrestrial Broadcast(8VSB): 2-69 • Digital Cable (QAM): 1-135
Tuner type	Frequency synthesized	
Inputs	Video: 1.0 V (p-p), 75 ohms Audio: 2Vrms Max. Component video: (Y) 1.0 V (p-p), 75 ohms, (Pb)/(Pr) 0.7 V (p-p), 75 ohms HDMI: HDMI 2.0, ARC, CEC HDCP 2.2 Scan rates: 480i, 480p, 720p, 1080i, 1080p, 2160p Antenna: VHF/UHF In 75 ohms coaxial	
Outputs	Digital audio: Optical Headphone (3.5mm Stereo)	
Audio output power	10W + 10W	
Power supply	AC 100 - 240V, 50 - 60Hz	
Power consumption	Operation: 120W Standby: <0.5W	
Weight	22.1lbs (10.0kg)	
Dimensions	Width: 42 - 11/16" (108.3 cm) Height: 26 - 3/4" (67.8 cm) Depth: 10 - 1/4" (26.0 cm)	
Operating temperature	5°C - 35°C	
Operating humidity	Less than 80% RH	
Accessories	Remote control Batteries (AAA) × 2 AC Cord Stands x 2 (R / L), Stand Screws x4 Owner's Guide Quick Start Guide Component Adapter	

- Designs and specifications are subject to change without notice.
- For information on our other products, please visit our website at www.hitachi.us

800.HITACHI
(800.448.2244)

Monday ~ Friday
9:00 am - 6:00 pm EST

www.hitachi.us/tv



Sincere - Prompt - Efficient

HITACHI
Inspire the Next

HITACHI AMERICA, LTD., DIGITAL MEDIA DIVISION

HITACHI has made every effort to assure you enjoy trouble free operation from your Hitachi product. Should you require service assistance with **OPERATIONAL, HOOK UP, TECHNICAL ASSISTANCE OR WARRANTY SERVICE SUPPORT**, please contact one of our knowledgeable Customer Service Advocates at **800.HITACHI (800.448.2244)**.

Please be prepared to submit proof of purchase and/or delivery receipts to your 800.HITACHI Customer Service Representative. Warranty coverage will be provided in accordance with the provisions of your Limited Warranty (see the Limited Warranty page in this operating guide).

Pour de plus amples renseignements sur le service durant la période couverte par la garantie, sur le fonctionnement ou pour de l'assistance technique communiquez avec:

Au Canada: 800.HITACHI (800.448.2244)

Lundi ~ Vendredi 9:00 am - 6:00 pm HNE

Hitachi America, Ltd., Digital Media Division
Customer Service Support
P.O. Box 99652
Troy, MI 48099

customerservice.ce@hal.hitachi.com



Congratulations on your purchase of a new Hitachi display product.

LIMITED WARRANTY:

Hitachi America Ltd., warrants this product in accordance with the terms and conditions applicable to the products identified below:

Conditions of "Hitachi " Limited Warranty: This Hitachi display product (the "Product") is warranted to be free from defects in materials and workmanship beginning on the date of purchase by the original owner and continuing for the duration of the applicable time periods specified below. If the Product is found to be defective, Hitachi will repair or replace (at Hitachi's option) defective parts at no charge, subject to the conditions of this Limited Warranty. If the original owner rejects, refuses or otherwise does not accept Hitachi's offer to repair or replace such defective parts under this Limited Warranty, this Limited Warranty shall be void and of no further force or effect. This Limited Warranty extends to the original owner only and is not transferable, and such owner must provide a dated sales receipt for the Product to qualify for parts or service under this Limited Warranty. The original owner must notify Hitachi of a defect claim by calling 800-HITACHI during the applicable Limited Warranty period for this Limited Warranty to be effective. This Limited Warranty is valid only in the U.S.A., Canada and Puerto Rico.

Hitachi Product: LCD Flat Panel Televisions PARTS : The Limited Warranty period for parts is 1 year from the date of original purchase. During the Limited Warranty period for parts, Hitachi will replace defective parts with new or rebuilt parts (at Hitachi's option) at no charge for such parts. Any replacement part will be warranted for the remainder of the original warranty period applicable to the part replaced. **LABOR :** The Limited Warranty period for labor is 1 year from the date of original purchase. During the Limited Warranty period for labor, Hitachi will repair or replace (at Hitachi's option) defective parts without charge for labor. **SERVICE LOCATION :** In-home warranty service, which includes either in-home repair or free pick-up and delivery (at Hitachi's option), applies to all Hitachi products except: (i) 43-inch and smaller LCD Flat Panel Televisions; (ii) Products located outside the U.S.A., Canada or Puerto Rico; (iii) Products located more than seventy-five (75) driving miles from Hitachi's nearest Authorized Service Facility. If the foregoing clauses (i), (ii), (iii) apply, then the Product owner will be responsible for bringing/delivering the Product to a Hitachi Authorized Service Facility and, following warranty service, retrieving the Product from such Authorized Service Facility.

IMPORTANT: Before using or installing your Product, please complete this form and attach your sales receipt and retain them for your records. This will help facilitate proper warranty coverage.

MODEL NO.
DEALER NAME
DEALER ADDRESS
CITY

SERIAL NO.
DATE OF PURCHASE
STATE / PROVINCE

Warranty Limitations. THIS HITACHI LIMITED WARRANTY DOES NOT COVER: A. Any Product that has been modified or repaired in a manner not previously authorized by Hitachi in writing. B. Any Product, whose serial number has been removed, altered, replaced, defaced or rendered illegible. C. Any defect, malfunction, or failure caused by or resulting from improper or unauthorized service, maintenance or repair. D. Damage resulting from abuse, misuse, mishandling, neglect or damage caused by exposure to hostile operating environments such as areas containing dust and/ or smoke. E. Damage caused by power surges, accidents, natural disasters or any other events or circumstances outside Hitachi's control. F. Any Product used in any manner inconsistent with the acceptable set-up, usage, safety or installation configurations identified in the Product's Operating Guide. G. Any Product used for purposes or applications, or subjected to operating conditions, other than those identified as acceptable in the Product's Operating Guide. H. Product repairs (including any product whose case has been opened), or part replacements provided or installed, by any person other than an Authorized Hitachi Service Facility Representative. I. Improper uncrating, set-up or installation or any misadjustments caused by user-operated controls. J. Any labor or costs associated with removing the Product from a custom cabinet or other specialized product installation that impedes direct and immediate removal of the Product from the owner's premises (must be arranged and paid by the owner). K. Product cabinets, cabinet parts, knobs, batteries, accessories, or any third party's branded hardware or peripheral devices, including any software incorporated therein, whether or not included within the Product's original packaging. L. Product screens that have been cleaned by any method other than as specified in the Product's Operating Guide. M. Normal usage, degraded brightness caused by backlight aging and/or cell defects or ordinary wear and tear, including, without limitation, scratches or marks on the Product's screen, cabinet or the appearance of bright or dark screen pixels. N. Any Product returned for service that is damaged due to improper packaging, mishandling or shipping. (IMPORTANT: When shipping any Product to a Hitachi Authorized Service Facility, Product owner must package it securely in the original shipping container or its equivalent to prevent damage. The Product must be returned with the shipping charges prepaid and proof of purchases included in the shipping container. Failure to properly package such product during such shipment will void all warranties.) O. Any Product purchased or serviced outside the U.S.A., Canada and Puerto Rico. P. Any Product that has been used for commercial purposes.

NO PERSON, AGENT, DISTRIBUTOR, DEALER, SERVICE FACILITY, OR COMPANY IS AUTHORIZED TO CHANGE, MODIFY OR AMEND THE TERMS OF THIS LIMITED WARRANTY IN ANY MANNER WHATSOEVER, EXCEPT AS PROVIDED IN THIS LIMITED WARRANTY. HITACHI MAKES NO EXPRESS WARRANTY REGARDING THIS HITACHI PRODUCT. FURTHER, ALL IMPLIED WARRANTIES RELATING TO ANY PORTION OF THIS PRODUCT, INCLUDING ANY WARRANTY OF MERCHANTABILITY OR FITNESS FOR A PARTICULAR PURPOSE, ARE LIMITED TO THE DURATION SPECIFIED UNDER THIS LIMITED WARRANTY. HITACHI SHALL NOT BE LIABLE TO THE PURCHASER OR TO ANY OTHER PERSON FOR ANY INCIDENTAL OR CONSEQUENTIAL DAMAGES OR LOSS OF PROFIT OR PRODUCT RESULTING FROM ANY DEFECT IN, OR MALFUNCTION OR FAILURE OF, THIS HITACHI PRODUCT, BECAUSE SOME JURISDICTIONS DO NOT ALLOW LIMITATIONS ON HOW LONG AN IMPLIED WARRANTY LASTS, OR THE EXCLUSION OF INCIDENTAL OR CONSEQUENTIAL DAMAGES. THE ABOVE LIMITATIONS MAY NOT APPLY TO YOU. THIS LIMITED WARRANTY CONFERS SPECIFIC LEGAL RIGHTS, INCLUDING CERTAIN OTHER RIGHTS THAT MAY VARY DEPENDING ON YOUR JURISDICTION. THIS LIMITED WARRANTY SHALL BE GOVERNED BY AND CONSTRUED IN ACCORDANCE WITH THE LAWS OF THE JURISDICTION OF THE PRODUCT OWNER'S RESIDENCE.

