



HL200 MIXER TECHNICAL MANUAL

SPECIFICATION SHEET

INSTALLATION INSTRUCTIONS

OPERATION INSTRUCTIONS

CLEANING INSTRUCTIONS

MAINTENANCE INSTRUCTIONS

TROUBLE SHOOTING INSTRUCTIONS

WIRING DIAGRAMS

CATALOG OF REPLACEMENT PARTS

SMARTPARTS™ USER GUIDE

RECOMMENDED SPARE PARTS LIST

Need other Hobart Services?



- [Warranty Registration](#)
- [Delivery and Installation](#)
- [Preventive Maintenance](#)
- [Hobart Service Contracts](#)
- [Extended Warranty Contracts](#)
- [Parts and Accessories](#)
- [Specialty Programs](#)
- [Water Treatment Programs](#)



HOBART701 S Ridge Avenue, Troy, OH 45374
1-888-4HOBART • www.hobartcorp.com**LEGACY®
HL200 MIXER****HOBART****STANDARD FEATURES**

- Heavy-Duty ½ H.P. Motor
- Gear Transmission
- Three Fixed Speeds Plus Stir Speed
- Shift-on-the-Fly™ Controls
- Patented soft start Agitation Technology
- 15-Minute SmartTimer™
- Automatic Time Recall
- Large, Easy-To-Reach Controls
- Single Point Bowl Installation
- Ergonomic Swing-Out Bowl
- #12 Taper Attachment Hub
- Open Base
- Stainless Steel Bowl Guard
- Metallic Gray Hybrid Powder Coat Finish

ACCESSORY PACKAGES - featuring Hobart Quick Release™ Agitators

- Deluxe Accessory Package Includes:**
 - 20 Quart Stainless Steel Bowl
 - 20 Quart “B” Beater
 - 20 Quart “D” Wire Whip
 - 20 Quart Bowl Scraper
 - 20 Quart Ingredient Chute
- Standard Accessory Package Includes:**
 - 20 Quart Stainless Steel Bowl
 - 20 Quart “B” Beater
 - 20 Quart “D” Wire Whip

MODELS

- HL200 – 20-Quart All Purpose Mixer
- HL200C – 20-Quart All Purpose Mixer with Maximum Security Correctional Package

OPTIONS

- SmartPlus2™ Programmable Recipe Timer

Specifications, Details and Dimensions on Inside and Back.

**LEGACY® HL200 MIXER**

LEGACY® HL200 MIXER



701 S Ridge Avenue, Troy, OH 45374
1-888-4HOBART • www.hobartcorp.com

SOLUTIONS/BENEFITS

½ H.P. Motor

Durability

- Heavy-duty to meet the most demanding operations

Gear Transmission

Durability, Reliability

- Ensures consistent performance and minimum downtime under heavy loads

Three Fixed Speeds plus Stir Speed

Flexibility, Reliability, Consistency

- For incorporating, blending, mixing ingredients
- Supports consistent results and thorough mixing

Shift-on-the-Fly™ Controls

Flexibility

- Allows operator to change speeds while mixer is running

Patented soft start Agitation Technology

Sanitation

- Each speed has a soft transition into a higher speed to reduce the chances of product splash-out

15-Minute SmartTimer™

Convenience, Ease of Use, Consistency

- Supports recipe mixing times
- Provides accurate results and eliminates overmixing

Automatic Time Recall

Productivity, Consistency

- Remembers the last time set for each speed
- Great for multiple batches

Ergonomic Swing-Out Bowl

Ease of Use, Convenience

- Easy loading and unloading of products
- Single Point Bowl Installation allows for simple mounting and removal of bowl
- Bowl Interlock ensures mixer bowl is properly in place for mixer to operate

Stainless Steel Bowl Guard

Protection

- Safety interlock prevents operation when front portion of guard is out of position

Hobart Accessories

Durability, Flexibility, Simplicity

- Hobart Quick Release™ agitators allow for simple installation and removal from agitator shaft
- Hobart accessories are designed for long-term usage under heavy-duty conditions
- Large array of accessories provide multiple uses for recipe and product processing

HL200 MIXER CAPACITY CHART

Recommended Maximum Capacities - dough capacities based on 70°F. water and 12% flour moisture.

PRODUCT	AGITATORS SUITABLE FOR OPERATION	HL200
CAPACITY OF BOWL (QTS. LIQUID)		20
Egg Whites	D	1 qt.
Mashed Potatoes	B & C	15 lbs.
Mayonnaise (Qts. of Oil)	B or C or D	10 qts.
Meringue (Qts. of Water)	D	1½ pts.
Waffle or Hot Cake Batter	B	8 qts.
Whipped Cream	D or C	4 qts.
Cake, Angel Food (8-10 oz. cake)	C or I	15
Cake, Box or Slab	B or C	20 lbs.
Cake, Cup	B or C	20 lbs.
Cake, Layer	B or C	20 lbs.
Cake, Pound	B	21 lbs.
Cake, Short (Sponge)	C or I	15 lbs.
Cake, Sponge	C or I	12 lbs.
Cookies, Sugar	B	15 lbs.
Dough, Bread or Roll (Lt.-Med.) 60% AR	§ ED	25 lbs.□
Dough, Heavy Bread 55% AR	§ ED	15 lbs.□
Dough Pie	B & P	18 lbs.
Dough, Thin Pizza 40% AR (max. mix time 5 min.)	§‡ ED	9 lbs.□
Dough, Med. Pizza 50% AR	§‡ ED	10 lbs.□
Dough, Thick Pizza 60% AR	§‡ ED	20 lbs.□
Dough, Raised Donut 65% AR	ED	9 lbs.*
Dough, Whole Wheat 70% AR	ED	20 lbs.□
Eggs & Sugar for Sponge Cake	B & C or I	8 lbs.
Icing, Fondant	B	12 lbs.
Icing, Marshmallow	C or I	2 lbs.
Shortening & Sugar, Creamed	B	16 lbs.
Pasta, Basic Egg Noodle (max. mix time 5 min.)	ED	5 lbs.

NOTE: % AR (% Absorption Ratio) - Water weight divided by flour weight. Capacity depends on moisture content of dough. Above capacities based on 12% flour moisture at 70°F water temperature.

□ 1st Speed

* 2nd Speed

† 3rd Speed

§ If high gluten flour is used, reduce above dough batch size by 10%.

‡ 2nd Speed should never be used on 50% AR or lower products.

USE OF ICE REQUIRES A 10% REDUCTION IN BATCH SIZE.

1 gallon of water weighs 8.33 lbs.

NOTE: Attachment hub should not be used while mixing.



701 S Ridge Avenue, Troy, OH 45374
1-888-4HOBART • www.hobartcorp.com

LEGACY® HL200 MIXER

SPECIFICATIONS

MOTOR:

½ H.P. high torque motor.

100-120/50/60/1 8.0 Amps
200-240/50/60/1 5.0 Amps

ELECTRICAL:

100-120/50/60/1, 200-240/50/60/1 – UL Listed.

CONTROLS:

Magnetic contactor with thermal overload protection. Internally sealed “Start-Stop” push buttons. A 15-minute SmartTimer™ is standard. SmartTimer™ includes **Automatic Time Recall**, which remembers the last time set for each speed. Optional SmartPlus2™ Programmable Recipe Timer allows operators the ability to program up to 4 recipes with 5 steps per recipe. SmartPlus2™ automatically changes speeds and starts timer count-down without operator intervention.

TRANSMISSION:

Gear-driven. Gears are constant mesh heat-treated hardened alloy steel along with anti-friction ball bearings. Grease lubricants furnished to all gears and shafts.

SPEEDS:

	Agitator (RPM)	Attachment (RPM)
Stir	59	33
First (Low)	107	61
Second (Intermediate)	198	113
Third (High)	365	207

BOWL GUARD:

Heavy-duty stainless steel wire front and solid rear portion. Front portion of guard rotates easily to add ingredients and install or remove agitator. It detaches in seconds for cleaning in dishwasher or sink. Rear portion of guard can be quickly cleaned in position. Guard must be in closed position before mixer will operate. Bowl support interlock provides further protection.

BOWL LIFT:

Ergonomic style, hand crank operated, self-locking in top and bottom position.

FINISH:

Metallic Gray Hybrid Powder Coat finish.

ATTACHMENT HUB:

Comes with front-mounted Hobart standard #12 taper attachment hub for use with Hobart #12 size attachments.

ATTACHMENTS AND ACCESSORIES:

The following are available at extra cost:

- Stainless Steel Bowl
- “B” Flat Beater
- “C” Wing Whip
- “D” Wire Whip
- “E” Dough Hook
- “ED” Dough Hook
- “P” Pastry Knife
- Bowl Splash Cover
- Bowl Scraper
- Ingredient Chute
- 12 Quart Accessories
- 9" Vegetable Slicer
- Meat Chopper Attachment
- Rubber Foot Pads
- Attachment Tray Support



Hobart Bowl Scraper

Hobart Ingredient Chute



Listed by Underwriters Laboratories Inc. and certified by NSF International.

LEGACY® HL200 MIXER



701 S Ridge Avenue, Troy, OH 45374
1-888-4HOBART • www.hobartcorp.com

SPECIFICATIONS

ELECTRICAL SPECIFICATIONS: 100-120/50/60/1,
200-240/50/60/1 – UL Listed.

WEIGHT: 189 lbs. net; 204 lbs. domestic shipping.

WARRANTY: Unit has full one-year warranty on
parts, labor and mileage against manufacturer's
defects. Service contracts are available.

DETAILS AND DIMENSIONS

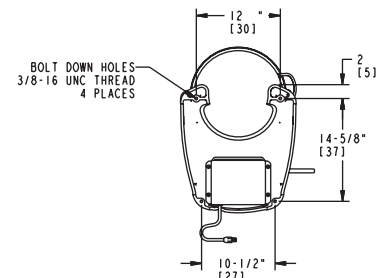
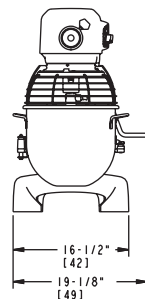
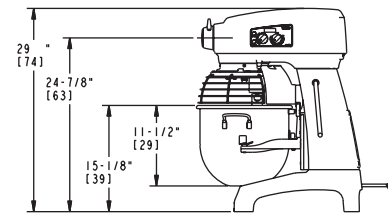
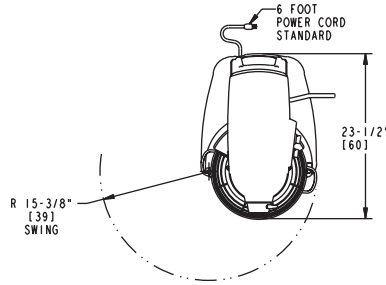
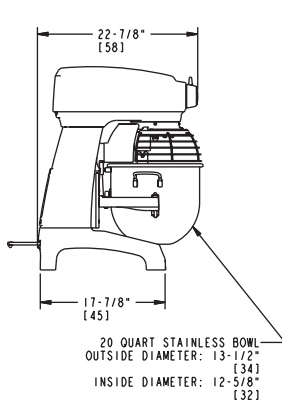

WARNING

ELECTRICAL AND GROUNDING CONNECTIONS MUST
COMPLY WITH THE APPLICABLE PORTIONS OF
THE NATIONAL ELECTRICAL CODE AND/OR
OTHER CODES IN FORCE

NOTE

MACHINE WEIGHT (LESS BOWL)----- 189 LBS
SHIPPING WEIGHT----- 204 LBS
BOWL WEIGHT----- 9 LBS

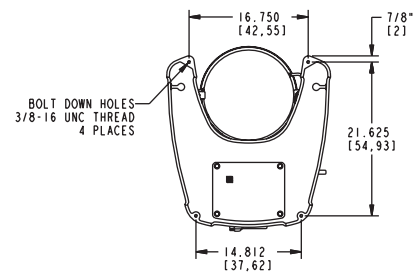
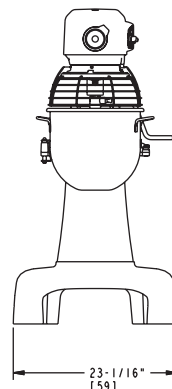
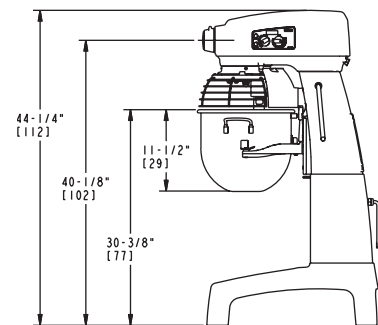
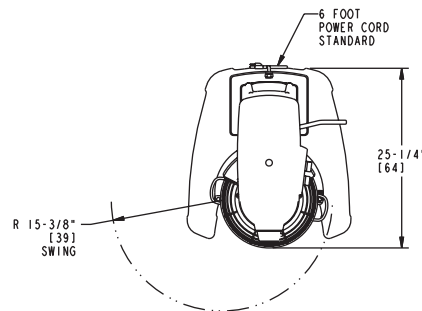
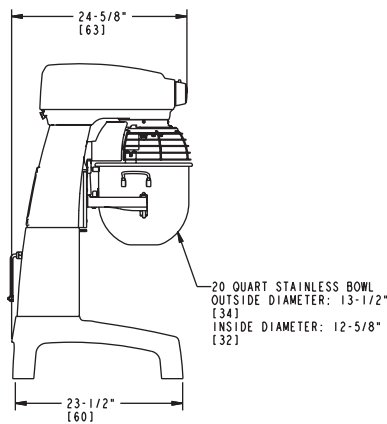

WARNING

ELECTRICAL AND GROUNDING CONNECTIONS MUST
COMPLY WITH THE APPLICABLE PORTIONS OF
THE NATIONAL ELECTRICAL CODE AND/OR
OTHER CODES IN FORCE

NOTE

MACHINE WEIGHT (LESS BOWL)----- 265 LBS
SHIPPING WEIGHT----- 280 LBS
BOWL WEIGHT----- 9 LBS

As continued product improvement is a policy of Hobart, specifications are subject to change without notice.

HOBART

LEGACY™



Models

HL120	ML-134296	ML-134459
HL200	ML-134331	ML-134458
HL200	ML-134289	ML-134457
HL200	ML-134455	

PRIOR ML'S COVERED IN THIS CATALOG

HL200	ML-134308
HL200	ML-134450

F34922 Rev. D (Nov. 2008)

TABLE OF CONTENTS

GENERAL	3
INSTALLATION.....	3
Unpacking	3
Location	3
Electrical Connections	4
OPERATION	5
Standard Controls	6
Recipe Timer Control.....	7
Bowl Placement.....	8
Agitator	8
Prepare for Mixing	9
Standard Timer Operation	9
Recipe Timer Operation	11
View Recipe	12
Programming Recipe Timer	12
Unloading	14
Wire Cage.....	14
Agitators and Attachments	16
CLEANING	17
MAINTENANCE	18
Lubrication	18
Adjustments	19
TROUBLESHOOTING	20
Service.....	20

Installation, Operation and Care of Legacy™ 12 & 20-Quart Mixers

SAVE THESE INSTRUCTIONS

GENERAL

The Legacy 12-quart mixer is a bench-type mixer which features a SmartTimer™, a manual bowl lift and a #12 attachment hub as standard equipment.

The Legacy 20-quart mixer is a bench-type mixer which features a SmartTimer™, a manual bowl lift and a #12 attachment hub as standard equipment. With the use of special agitators, a 12 quart bowl may be used on the HL200 mixer.

A variety of attachments, agitators and accessories are available. These are described in a separate *Use and Applications Handbook*, which is furnished on the Legacy Mixer Operator Training CD provided with each mixer.

INSTALLATION

UNPACKING

Immediately after unpacking the mixer, check for possible shipping damage. If this machine is found to be damaged after unpacking, save the packaging material and contact the carrier within 15 days of delivery.

LOCATION

Prior to installation, test the electrical service to assure that it agrees with the specifications on the machine data plate.

Place the mixer on a suitable sturdy level surface. There should be adequate space around the mixer for the user to operate the controls and to install and remove bowls.

Holes are located in the base to permanently secure the mixer, although this is not necessary in normal installations.

ELECTRICAL CONNECTIONS (Cord Connected Mixers)

⚠ WARNING The electrical cord on this machine is equipped with a three-pronged grounding plug which must be connected to a properly grounded receptacle. If the receptacle is not the proper grounding type, contact an electrician. Do Not remove the grounding prong from the plug.

⚠ WARNING Electrical and grounding connections must comply with the applicable portion of the national electrical code and/or other local electrical codes.

Check Initial Operation

1. Apply power to the mixer by inserting the cord plug into a properly grounded outlet.
2. Install the bowl and raise into mix position, with the bowl support up and bowl guard wire cage closed.
3. Turn the SPEED dial pointer to STIR.
4. Momentarily run the machine by pushing the START and then STOP buttons.

OPERATION

⚠ WARNING Moving agitator in bowl. Keep hands, clothing, and utensils out of bowl operation. Do Not use without interlocked guard.

The Legacy mixer is equipped with SmartTimer™ controls. Refer to Fig. 1 for operating parts and OPERATION section for their functions.

The bowl guard wire cage must be in closed position or the mixer will not operate.

The bowl must remain in mix position on bowl support and the bowl support must be raised (mix position) or the mixer will not operate.



Fig. 1

Standard Controls

Models HL120/HL200 (With Three Mix Speeds Plus Stir Speed)

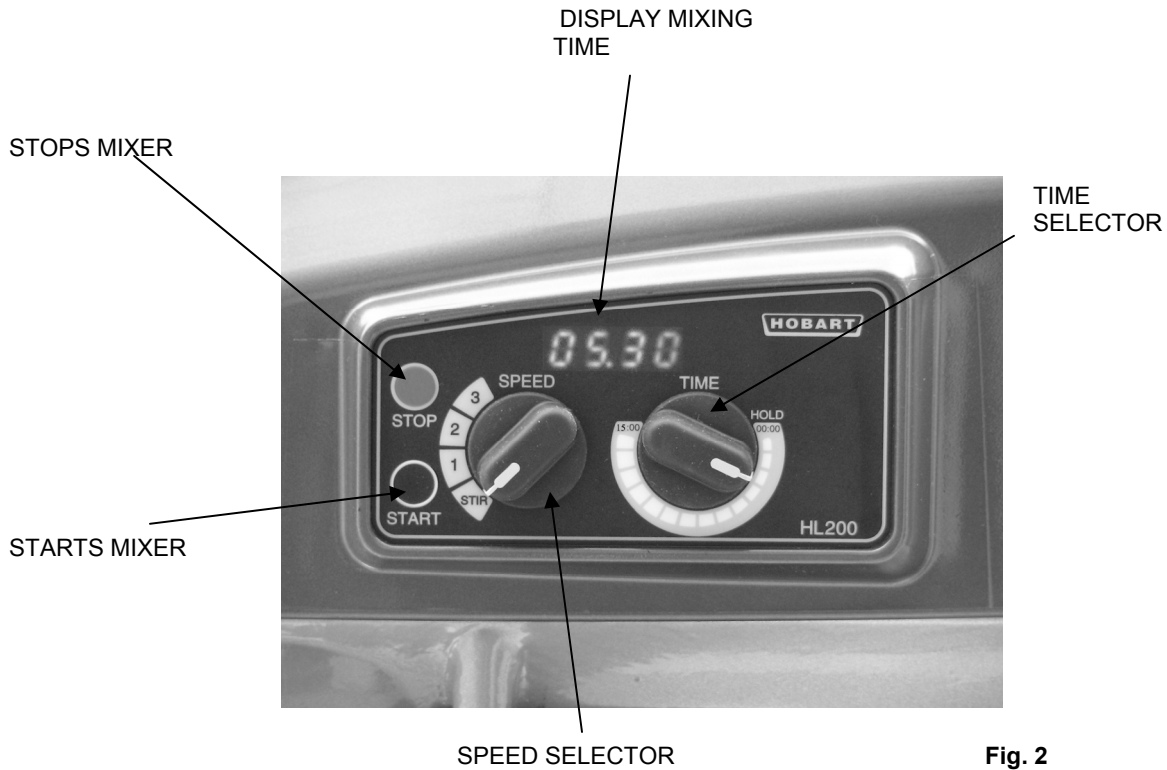

HL120/HL200 Mixer Speeds

- | | |
|------------------|--|
| STIR (Slow) | The lowest speed is for incorporating ingredients. |
| SPEED 1 (Low) | This speed is for heavy mixtures such as pizza dough, heavy batters and potatoes. |
| SPEED 2 (Medium) | This speed is for mixing cake batters, mashing potatoes and developing bread dough. |
| SPEED 3 (High) | This speed is for incorporating air into light batches, as well as finishing whipped items |

Recipe Timer (Optional)

Models HL120/HL200 (With Three Mix Speeds Plus Stir Speed)



Fig. 15

The SmartPlus2™ recipe timer has two operating modes, Standard (STD) and RECIPE.

Standard Mode

Operates exactly as the standard controls utilizing continuous and timed mixing.

Recipe Mode

- Use mode buttons to switch mixer operation between recipe and standard timed operation.
- Up to 4 recipes can be stored in memory
- Each recipe can contain 5 steps
- Each step can be programmed to operate with the following speeds and time.

SPEED SETTINGS

SPd 1 (DEFAULT)
SPd 2
SPd 3
Stir
PAUS (pause – no mixing)

TIME SETTINGS

00:00 – 15:00 minutes (10 second increments)
End (default)

BOWL PLACEMENT

The bowl must be installed before the agitator is installed.

To install the bowl, lower the bowl support and position bowl so the alignment pins on the left side of the bowl support fit in the holes in the bowl tab. (Fig. 3) Place the slotted tab on bowl into the lower part of the pin. Swing the bowl into the mix position on bowl support. (Fig. 4)



Fig. 3



Fig. 4

AGITATOR

To install an agitator, the bowl must be on the bowl support.

To Install

1. Lower the bowl.
2. Open the bowl guard wire cage.
3. Place the agitator inside the bowl and align the horizontal slot on the agitator with the agitator shaft pin.
4. Slide the agitator up the agitator shaft until it stops and latches. An audible click should be heard when the agitator locks in position.

To Remove

1. Open the bowl guard wire cage.
2. Lower the bowl.
3. Hold the agitator and pull the plunger of the agitator out (Fig. 5). Slide agitator down off the agitator shaft.



Fig. 5

PREPARE FOR MIXING

1. Place the mixing bowl on the bowl support.
2. Pour ingredients into the bowl.
3. Swing the bowl back to the mix position.
4. Place the agitator inside the bowl, and then attach it to the agitator shaft (Fig. 6).
5. Lift bowl support.
6. Correctly close the bowl guard wire cage.
7. The mixer is now ready for mixing. (See TIMER OPERATION.)



Fig. 6

STANDARD TIMER OPERATION

Using the Count-Up Mode (Continuous Mixing)

1. Turn the SPEED dial to select a mix speed (the SPEED setting can be changed at any time during the mixing operation).
NOTE: STIR is to be used for incorporating ingredients. Do not use to develop dough products.
2. Set the timer on hold by turning the TIME selector counterclockwise until HoLd appears in the TIME window.
3. Press the START button to begin mixing. The timer starts counting forward from 00:00.
NOTE: If the wire cage is opened at any time, the mixing operation will stop. To resume the mixing operation, close the wire cage and press the START button.
4. Use the STOP button to stop the mixer; the mixing time is displayed in the TIME window.
5. Press the START button to resume mixing if needed.
NOTE: When the timer reaches 15:00 minutes, the beeper will sound momentarily and timer will rollover to 00:01 and continue counting until the STOP button is pressed.

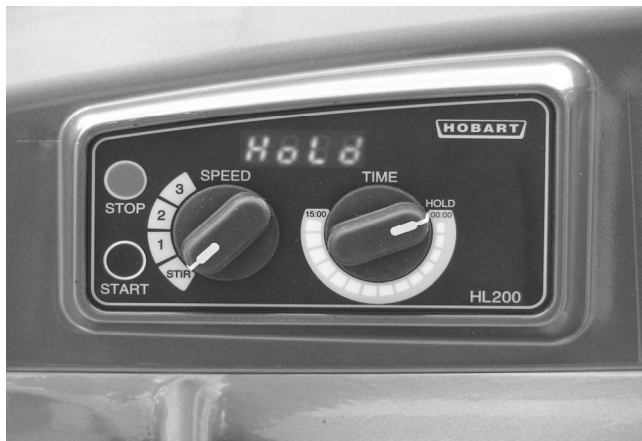

Fig. 7

Using the Count-Down Mode (Timed Mixing)

1. Turn the SPEED dial to select a mix speed.
 - a. If the count-up mode was used for the previous batch, the desired time needs to be entered.
 - b. If the count-down mode was used for the previous batch, the previous time will be displayed. If a different time is needed, turn the TIME selector to the desired time in 10 second increments.
2. Press the START button to begin mixing; the timer starts counting down from the set time.
 - a. To stop the mixer at any time, press the STOP button. To resume mixing, press the START button. For example: The mixer is started at SPEED 1 for 30 seconds and is stopped after 10 seconds. Pressing the START button will resume the mixing operation.
 - b. If the mixer is stopped and a new time setting is entered, pressing the START button saves the new time setting on the current speed selection.

For example: The mixer is started at SPEED 1 for 30 seconds and is stopped after 10 seconds. A new time is entered by turning the TIME selector. The new time will replace the initial 30 seconds for SPEED 1 after the START button is pressed.
 - c. If the time is changed while mixing, the mixer will operate until the new time expires. The adjustment to the time will not be stored.
 - d. If speed is changed while mixing, the time will change to the previous time for the selected speed and count down.

NOTE: If the wire cage is opened at any time, the mixing operation will stop. To resume the mixing operation, close the wire cage and press the START button.
3. When the timer reaches 00:00, the mixer stops; a beeper sounds for 1 second. The count-down timer then displays the last-stored time.

OPERATING NOTES

- STIR is to be used for incorporating ingredients. Do not use it to develop dough products.
- If the mixer is stopped during a mixing operation, the timer also stops. The timer starts again (with the time remaining) when the START button is pressed.
- Turn the TIME selector clockwise to take the mixer out of the hold mode.

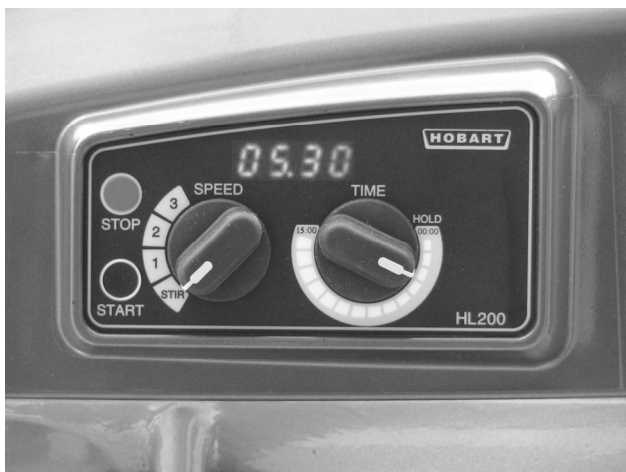

Fig. 8

RECIPE TIMER OPERATION



Recipe Timer Notes

- If pause is selected as a mix speed, the mixer START button must be pressed to advance to the next recipe step after the pause time has expired.
- If pause has been selected, the bowl guard can be opened and the time will continue to count down.
- The recipe step can be interrupted and then resumed by pressing the STOP button and then the START button.

NOTE: If PAUSE has been selected, the STOP button is disabled.

- The recipe can be terminated by stopping the mixer and pressing the STD button.

Using The Recipe Timer

1. Press Recipe mode button.
2. Turn the RECIPE selector to select a recipe.
3. Press START; mixer will operate at the programmed speed for the programmed time.
 - a. Speed is displayed momentarily.
 - b. Remaining time for the operating step will be displayed and the step light is flashing.

NOTE: Recipe and Time selectors are disabled.

4. Mixer will continue to perform the programmed speeds and times until the recipe steps are completed.

NOTE: If pause has been programmed for a step speed, the mixer START button must be pressed to advance to the next recipe step after the pause time has expired.

5. When the timer reaches the end of the last programmed recipe step, the mixer stops; the beeper sounds; the selected recipe is displayed.

View Recipe

When the mixer is in RECIPE mode, you can view the step settings of any recipe.

1. Press the SELECT/SAVE button.
 - A. Display will alternate between speed and time.
 - B. The LED of the step being displayed will flash.
2. Use the arrow buttons to view the next step.
3. Use the Recipe selector to view other recipes.
4. Press PGM button to return to the RECIPE mode.

NOTE: If the mixer is performing a recipe, the recipe will continue to operate in normal recipe mode sequence.

PROGRAMMING RECIPE TIMER



Fig. 16

HL200 is powered with display showing a mix time (Standard Mode) or recipe number (Recipe Mode).

1. If a mix time is displayed, Press RECIPE mode button. Display corresponds with position of recipe (speed) selector.
2. Press and hold TIME. Continue holding TIME, then press PGM and hold until rP1 is displayed (with step 1 blinking), buzzer sounds and programmed step LEDs are lit.
3. Use arrows to select recipe number (1-4) for programming.
4. Press SELECT/SAVE to enter program mode for the recipe number selected. Buzzer sounds and display alternates between speed and time to indicate programming mode.

NOTES:

- If a value has been assigned for a step number, that LED will be lit.
- The LED for the selected step will blink.
- If the default value is still assigned to a step, the LED will not be lit.
- When programming, the Recipe and Time Selectors are disabled.

SPEED SETTINGS

SPd 1 (DEFAULT)

SPd 2

SPd 3

Stir

PAUS (pause – no mixing)

TIME SETTINGS

00:00 – 15:00 minutes (10 second increments)

End (default)

5. Use arrows to select step number (1 – 5).
6. Press SPEED. All characters will blink and buzzer will sound.
 - A. Use arrows to select the mixing speed for selected step.
 - B. Press SELECT/SAVE to set the speed. SAVE displayed momentarily and buzzer sounds.
7. Display alternates between speed and time to indicate programming mode.
8. Press TIME. Third digit will blink and buzzer will sound.
 - A. Use arrows to select the mixing time (increments of 10 seconds) for selected step.

NOTE: If all 5 steps are programmed, the recipe will terminate at the end of step 5. If fewer than 5 steps are used, the default time setting of END will terminate the recipe.
 - B. Press SELECT/SAVE to set the time for the step. SAVE momentarily displayed and buzzer sounds.
9. Display alternates between speed and time to indicate programming mode.

NOTE: LED of step programmed will be flashing.
10. Use arrows to select next step.
11. Repeat setting speed and time for additional steps and use SELECT/SAVE to save settings.
12. After all steps for recipe are programmed, press PGM to exit programming mode. Buzzer sounds and display will show recipe number that was programmed with the number blinking.
13. Press PGM to enter run mode. (Buzzer sounds)
14. Press STD to return to standard mode or set recipe selector to the desired recipe.
15. Select the recipe that you programmed and verify proper operation.

UNLOADING

1. Open the bowl guard wire cage assembly.
2. Lower bowl support.
3. Remove the agitator from the agitator shaft.
4. Slightly lift the bowl off the pin (right side), pull bowl to the front and remove from the bowl support (left side).

WIRE CAGE

The bowl guard wire cage can be rotated out of the way to add ingredients or to access the bowl and agitator.

Note how the plastic carriers allow the wire cage to ride around the circumference of the planetary drip cup.

- Open the bowl guard wire cage: rotate it to your left (Fig. 9).
- Close the bowl guard wire cage: rotate it to your right until it stops, closed position (Fig. 10).

NOTE: The bowl guard wire cage must be returned to the closed position for the mixer to operate.



Fig. 9



Fig. 10

Remove and Clean Bowl Guard Wire Cage (Fig. 11)

1. Rotate wire cage to your left until the three carriers align with the carrier escape slots in the circular ridge of the planetary drip cup.
2. Lift the wire cage straight up so the carriers escape from the slots on the drip cup. The bowl guard wire cage can now be removed by pulling toward you.



Fig. 11

3. Wash the bowl guard wire cage in a sink, rinse with clear water, and dry with a clean cloth.
4. The splash guard can be wiped off and/or washed with a cloth or sponge using warm, soapy water. Rinse with clear water and dry with a clean cloth.

Reinstall Bowl Guard Wire Cage

1. Position the ring of the bowl guard wire cage so the carriers are positioned above the slots in the planetary drip cup.
2. Lower the bowl guard wire cage so the carriers pass through the slots.
3. Rotate the bowl guard wire cage to your right until it contacts the stop, closed position.

AGITATORS AND ATTACHMENTS

Attachments for attachment hub and agitators are covered in a separate Hobart Legacy Mixer Use and Application Handbook on the Mixer Operator Information CD. Follow the instructions accordingly.

Available Agitators and Attachments



12 & 20 Qt. B Flat Beater



12 & 20 Qt. D Wire Whip



12 & 20 Qt. ED Dough Hook



20 Qt. E Dough Hook



12 & 20 Qt. SST Bowl



12 & 20 Qt. Scraper



12 & 20 Qt. Splash Cover



12 & 20 Qt. C Wing Whip



12 & 20 Qt. P Pasty Knife

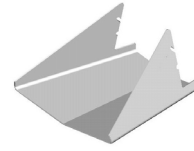

12 & 20 Qt. Ingredient Chute



12 & 20 Qt. Table

⚠ WARNING Unplug machine power cord before beginning any cleaning procedures.

The mixer should be thoroughly cleaned daily. DO NOT use a hose to clean the mixer, it should be washed with a clean, damp cloth. The base allows ample room for cleaning under the mixer. The apron (Fig 1), may be removed for cleaning by loosening the screws. The drip cup (Fig. 1) should be removed (which is secured with 3 screws) periodically and wiped clean. For cleaning the bowl guard wire cage refer to page 15.

⚠ WARNING Unplug machine power cord before beginning any maintenance procedures.

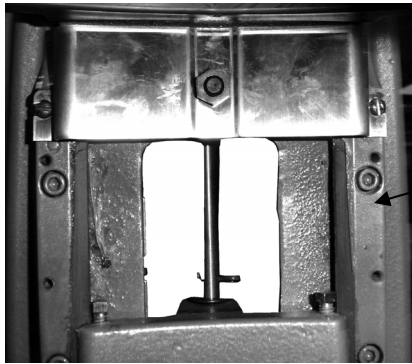

Slideway

Fig. 12



Planetary Seal

Fig. 13

LUBRICATION

Slideways

The slideways (Fig. 12) should be lubricated approximately twice a year. To reach these areas, fully lower the bowl support and remove the apron, which is secured by slotted screws. Wipe a thin coat of Lubriplate 630AA on the bowl pad area of the bowl supports and on each slideway. Install the apron.

Planetary Seal

Occasionally, the planetary seal (Fig. 13) may become dry and begin to squeak. To correct this, work a little lubrication (mineral oil) under the lip of the seal.

ADJUSTMENTS

Agitator Clearance

The agitator clearance should be checked periodically. The agitator must not touch the bowl and the maximum clearance between the bottom of the bowl and the B flat beater is 1/8" (3 mm); the maximum clearance between the bottom of the bowl and the ED dough arm is 5/16" (8 mm).

Install a bowl and agitator (e.g., beater). If the bowl and beater come into contact before the bowl support reaches its stop, adjust the stop screws. Refer to Adjust the Bowl/Agitator Clearance.

Measure Clearance

Pour enough flour in the bowl to cover the bottom of the bowl where the beater travels. With the bowl fully raised (beater should not touch the bottom of the bowl), briefly run the mixer at the lowest speed.

Turn off the mixer, disconnect the electrical power supply, and measure the depth of flour where the beater has traced a path. This measurement should be taken at several points around the bowl to assure accuracy.

Adjust the Bowl/Agitator Clearance

- Remove the apron (which is secured by screws).
- Adjust the clearance by moving the stop screws counterclockwise to increase the clearance or clockwise to decrease the clearance.
- After the adjustments are made, replace the apron and secure it with the screws.
- Carefully operate the bowl lift several times to check the adjustment.

Stop
Screw



Fig. 14

TROUBLESHOOTING

Symptoms	Possible Causes
Mixer will not start	Flashing Time Display – See Below Branch circuit protector is in open position - check fuse or disconnect switch. Mixer is overloaded. Wire cage is not in the closed position. Bowl is not in closed (mix) position or if Bowl in not in up position.
Agitator touches bowl	Bowl is not in closed (mix) position. Improper agitator clearance - see Maintenance for adjustment procedure. Agitator is not installed properly
Planetary seal squeaks	Seal requires occasional lubrication - see Maintenance
Timer displays flashing alarm code (Ex. "OL1" – Motor overload)	If the error code is flashing – unplug machine until display is blank then plug back in. If symptoms still exist, contact your local Hobart Service office.

SERVICE

If service is needed on this equipment, contact your local Hobart Service office.

1-888-4HOBART

USE AND APPLICATIONS HANDBOOK

For **HOBART** Mixer
LEGACY[®]
Attachments and Accessories

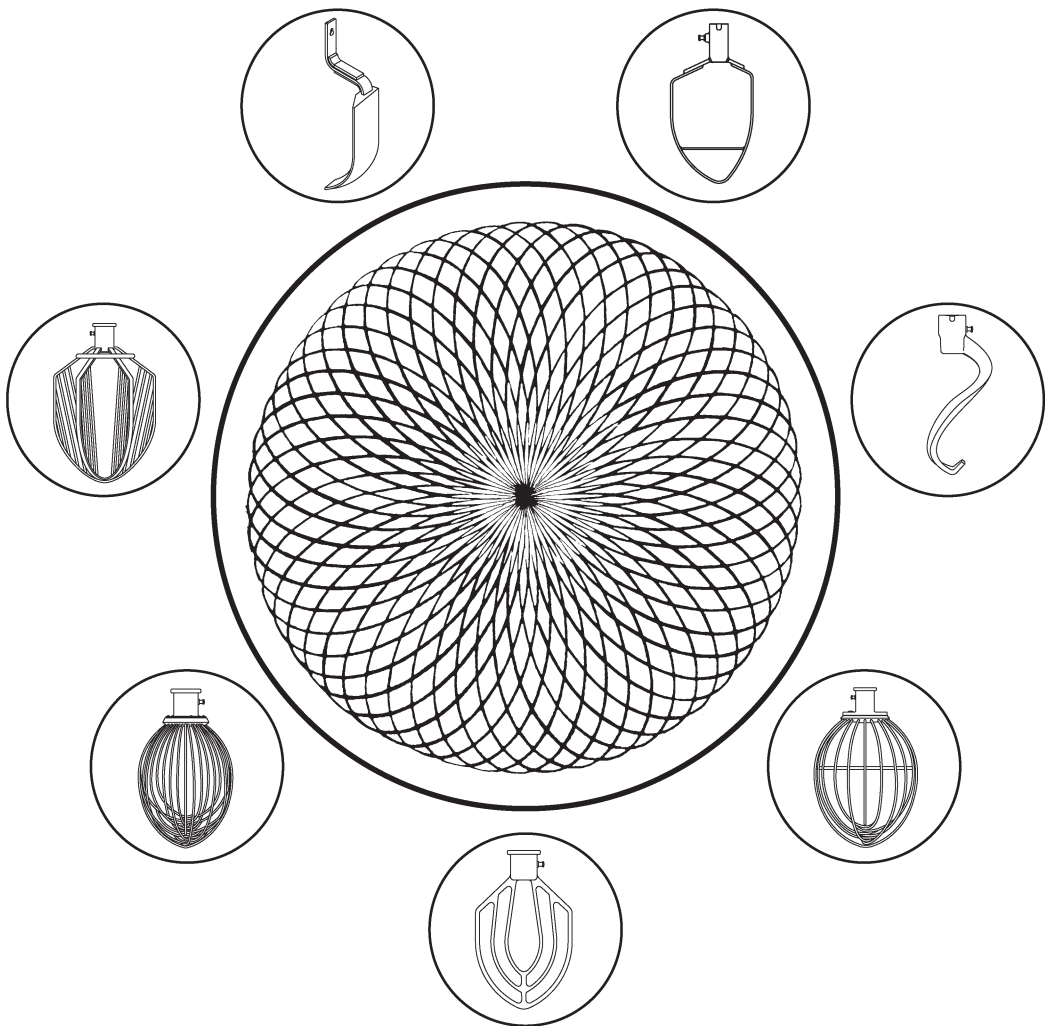

Economical, Dependable, Versatile . . . Your Hobart Mixer

The Hobart Mixer brings profit to your operation every time you use it. Uniform and consistent mixing reduces waste and improves process control. Smooth surfaces and durable construction make cleanup fast and easy. This all means economical operation for you.

Because of its reliability, your Hobart Mixer will give years of dependable, low cost service.

The Hobart Mixer's planetary action assures uniform mixing. The mix arm reaches every part of the batch. It rotates on its axis opposite to the direction that it moves around the bowl. Thorough mixing, blending and aerating of ingredients yields consistent, predictable results every time. You can depend on it.

Hobart Mixers are flexible in the kitchen. They quickly accept attachments to do many different jobs. They are also designed to optimize attachment operating speeds for various operations such as shredding, grinding and slicing. The Hobart Legacy allows for more than one size bowl, and several agitator styles are available to handle your specific mixing tasks. Your Hobart Mixer is adaptable to your needs.

We build them that way for you. Our reputation depends on it.



Beaters, Whips, Dough Hooks, Pastry Knives . . . and How to Use Them

This section illustrates and names the various mixer agitators and discusses their applications. General information on how to get the best results from your Hobart mixer is also provided. As is always the case with the art of cooking, your best creations are achieved by carefully proving your methods and formulas and evaluating the results.

The discussions on mixer performance and agitator uses are similar for planetary action mixers regardless of size. That is not to say that the same mix times will apply. This handbook offers suggestions and guidelines only. The cooking is up to you.

Attachments and accessories and their uses are discussed in the last section of the handbook.

CLEANING NEW MIXER BOWLS AND ACCESSORIES

Before using the first time, thoroughly wash new mixer bowls and agitators (beaters, whips, dough hooks and pastry knives). Wash in hot water and a mild detergent solution, rinse with either a mild soda or vinegar solution, and thoroughly rinse with clear water. Also follow this cleaning procedure for bowls and agitators before whipping egg whites or whole eggs.

AGITATORS AND THEIR USES

Hobart Quick Release™ agitators are available for the Legacy mixers and for the type of product that is being mixed.



The **B Flat Beater** is a multi-purpose agitator used for mashing potatoes and mixing cakes, batters or icings. It is also used in applications requiring a creaming or rubbing action and uniform dispersion of ingredients. Use first speed for starting most operations; medium speed for finishing.



The **D Wire Whip** is designed for maximum blending of air into light products. Uses include: whipping cream, beating egg whites, mixing very light icings, meringues and all similar applications. The D Wire Whip is most commonly used in third and fourth speed.



The **ED Dough Hook** is used for mixing most bread, roll and pizza doughs which require folding and stretching action for best development. These agitators are suitable for use on all yeast raised doughs and should be operated in first, second or third speed.

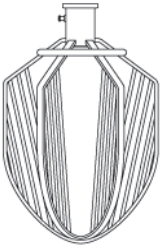

The **C Wing Whip** is used for whipping material that is too heavy for the D Wire Whip. The heavy frame permits its use for light creaming and beating. It is often used for whipping or blending potatoes, butter, mayonnaise or icings. It is generally used in first and second speed for whipping heavy products like potatoes or in third or fourth speed for lighter products like mayonnaise or icings.



The **P Pastry Knife** combines shortening with flour, and is ideal for light pastry shells (patty shells), flaky pie doughs and similar mixes. The cutting action of the knife practically eliminates rubbing and allows delicate ingredients to be combined without overdevelopment. The P Pastry Knife is suitable for stirring operations in low speeds and for fast cutting operations in medium speeds. You should not use the P Pastry Knife at high speed if you want the pastry to have a flaky texture.



The **I Wire Whip** makes sponge cakes and mixes marshmallow icing for heavy whipping.

FORMULAS AND METHODS

Use your own formula for any products you wish to make in your Hobart mixer. Then evaluate the finished product for texture, conformity, lightness, flakiness, etc. You will find that any method of blending ingredients can be duplicated or improved with your machine. Be careful and do not overmix. Overmixing can adversely affect the texture of your product. You will also discover there is often a saving in time for each mixing operation. Even delicate products usually mixed by hand can be mixed in your Hobart mixer.

Your Hobart mixer mixes your products in the most efficient and quickest way possible. There is no need for you to sacrifice individual characteristics when using your Hobart mixer. When results are exactly to your liking, note carefully the time of operation and the speed setting. Under the same conditions, your Hobart mixer will perform exactly the same, day after day, providing uniformity in your products.

MIXER CAPACITY

The Mixer Capacity Chart is a guide for controlling the batch sizes in your formulations. The capacities listed take into account the amount of product which can be contained in the various sized bowls. The listed capacities are the maximum recommended batch sizes. Whenever batch size exceeds 50 pounds, use a bowl truck to load and unload the bowl from the mixer. Recipes for doughs used to establish the batch sizes in the Mixer Capacity Chart are listed below:

INGREDIENT	HEAVY BREAD DOUGH	MEDIUM PIZZA DOUGH	RAISED DONUT DOUGH
Flour	100.0%	100.0%	100.0%
Water	55.0	50.0	65.0
Yeast	2.0	1.0	5.0
Salt	2.5	1.5	2.5
Sugar	5.0	-0-	15.0
Shortening	5.0	-0-	15.0
Oil	-0-	2.0	-0-
Non-Fat Dry Milk	6.0	-0-	8.0
Total	175.5%	154.5%	210.5%

The ingredient percentages are based on a flour content of 100 percent to simplify using the recipes to make various sized batches and compute the moisture absorption ratio. The heavy bread dough recipe above is a criterion listed in Section 4.4.2 of Federal Specification 00-M-0038K, Standard for Electric Food Mixing Machines.

The flour used in the recipes is hard wheat flour, enriched and bleached. It contains 11 to 12 percent protein content and a 12 percent moisture content. Flour which has a lower moisture content will decrease the moisture absorption, cause difficulty in proper gluten hydration, and make a heavier load on your mixer. Flours containing high quality protein, such as high gluten flour, result in a dough which can be very difficult to mix. If high gluten flour is used, reduce the batch quantity noted on the Mixer Capacity Chart by 10 percent to prevent overloading of the mixer.

The temperature of the water used in the recipes is 65°F to 75°F. Colder water temperature will cause the dough to be harder to mix. If you plan to mix doughs using cold water, the batch size may need to be reduced by 15 to 20%.

Also considered and noted on the Mixer Capacity Chart is the moisture absorption ratio (AR). This is the ratio of the weight of water to the weight of flour expressed as a percentage.

$$AR = \text{weight of water} \div \text{weight of flour} \leftrightarrow 100\%$$

The absorption ratio gives an indication of the relative "heaviness" or "wetness" of a batch. In fact, the capacities listed on the Mixer Capacity Chart for the products listed below are based on the following absorption ratios:

PRODUCT	ABSORPTION RATIO
Heavy Bread Dough	55%
Medium Bread Dough	60%
Light Bread Dough	65%
Thin Pizza Dough	40%
Medium Pizza Dough	50%
Thick Pizza Dough	60%
Raised Donut Dough	65%
Whole Wheat Dough	70%

When mixing any of the above products with an absorption ratio lower than listed, decrease the batch size proportionately to assure efficient mixing of the product and thus eliminate the possibility of overloading your mixer. For example: An HL600 mixer has a thin pizza dough capacity of 40 pounds at first speed based on an AR of 40% according to the Mixer Capacity Chart. If the batch has an AR of 30%, reduce the batch size to compensate for the difference. Compute the size of the reduction as follows:

- | | |
|--|---|
| <p>1. Divide the AR of the batch to be mixed by the AR listed on the Mixer Capacity Chart.</p> | $\frac{30\% \text{ Actual AR}}{40\% \text{ Rated AR}} = 75\%$ |
| <p>2. Multiply the rated batch size by the percentage obtained in step 1. The result is the maximum batch size of the HL600 mixer for pizza dough with 30% AR.</p> | $\begin{array}{r} 40 \text{ lbs. Rated Batch Size} \\ \times 75\% \\ \hline 30 \text{ lbs. Maximum Capacity} \\ \text{for 30\% AR Dough} \end{array}$ |

Another factor often overlooked is the ability of your mixer to operate at a different speed. To prevent overloading, use the recommended mix speed from the Mixer Capacity Chart. Because of the toughness of a 40% AR thin pizza dough, a maximum mix time of 5 minutes on first speed is recommended. Second speed should never be used on 50% AR or lower products except on model HL662.

The speed of the mixer, length of mix time, room temperature and ingredient temperatures all affect dough temperature. To achieve the desired final dough temperature, you may need to adjust the water temperature.

For batch size capacities on other bread doughs not mentioned on the Mixer Capacity Chart, follow the batch size recommendation for a listed bread dough with a similar absorption ratio.

Mixer Capacity Chart — HL120 & HL200

Recommended Maximum Capacities — dough capacities based on 70°F water and 12% flour moisture.

PRODUCT	AGITATORS SUITABLE FOR OPERATION	HL120	HL200
CAPACITY OF BOWL (QTS. LIQUID)		12	20
Egg Whites	D	1¼pts.	1 qt.
Mashed Potatoes	B & C	10 lbs.	15 lbs.
Mayonnaise (Qts. of Oil)	B or C or D	4½ qts.	10 qts.
Meringue (Qty. of Water)	D	¾ pts.	1½ pts.
Waffle or Hot Cake Batter	B	5 qts.	8 qts.
Whipped Cream	D or C	2½ qts.	4 qts.
Cake, Angel Food (8-10 oz. cake)	C	7	15
Cake, Box or Slab	B or C	12 lbs.	20 lbs.
Cake, Cup	B or C	12 lbs.	20 lbs.
Cake, Layer	B or C	12 lbs.	20 lbs.
Cake, Pound	B	12 lbs.	21 lbs.
Cake, Short (Sponge)	C	8 lbs.	15 lbs.
Cake, Sponge	C	6½ lbs.	12 lbs.
Cookies, Sugar	B	10 lbs.	15 lbs.
Dough, Bread or Roll (Lt.-Med.) 60% AR§	ED	13 lbs.*	25 lbs.*
Dough, Heavy Bread 55% AR§	ED	8 lbs.*	15 lbs.*
Dough, Pie	B & P	11 lbs.	18 lbs.
Dough, Thin Pizza 40% AR § † (max. mix time 5 min.)	ED	5 lbs.*	9 lbs.*
Dough, Med. Pizza 50% AR § †	ED	6 lbs.*	10 lbs.*
Dough, Thick Pizza 60% AR § †	ED	11 lbs.*	20 lbs.*
Dough, Raised Donut 65% AR	ED	4 lbs.**	9 lbs.**
Dough, Whole Wheat 70% AR	ED	11 lbs.*	20 lbs.*
Eggs & Sugar for Sponge Cake	B & C	5 lbs.	8 lbs.
Icing, Fondant	B	7 lbs.	12 lbs.
Icing, Marshmallow	C	1¼ lbs.	2 lbs.
Shortening & Sugar, Creamed	B	9½ lbs.	16 lbs.
Pasta, Basic Egg Noodle (max. mix time 5 min.)	ED	—	5 lbs.

ABBREVIATIONS - AGITATORS SUITABLE FOR OPERATION

- B - Flat Beater
- C - Wing Whip
- D - Wire Whip
- ED - Dough Hook
- P - Pastry Knife

- * 1st Speed
- ** 2nd Speed
- *** 3rd Speed

NOTE: %AR (% Absorption Ratio) = Water weight divided by flour weight. Capacity depends on moisture content of dough. Above capacities based on 12% flour moisture at 70°F water temperature.

§ If high gluten flour is used, reduce above dough batch size by 10%.

† 2nd speed should never be used on 50% AR or lower products.

Use of ice requires a 10% reduction in batch size.

1 gallon of water weighs 8.33 lbs.

NOTE: Attachment hub should not be used while mixing.

Mixer Capacity Chart — HL300 & HL400

Recommended Maximum Capacities — dough capacities based on 70°F water and 12% flour moisture.

PRODUCT	AGITATORS SUITABLE FOR OPERATION	HL300	HL400
CAPACITY OF BOWL (QTS. LIQUID)		30	40
Egg Whites	D	1½ qts.	1 ¾ qts.
Mashed Potatoes	B & C	23 lbs.	30 lbs.
Mayonnaise (Qts. of Oil)	B or C or D	12 qts.	13 qts.
Meringue (Qty. of Water)	D	1 qt.	1½ qts.
Waffle or Hot Cake Batter	B	12 qts.	16 qts.
Whipped Cream	D or C	6 qts.	9 qts.
Cake, Angel Food (8-10 oz. cake)	C or I	22	30
Cake, Box or Slab	B or C	30 lbs.	40 lbs.
Cake, Cup	B or C	30 lbs.	45 lbs.
Cake, Layer	B or C	30 lbs.	45 lbs.
Cake, Pound	B	30 lbs.	40 lbs.
Cake, Short (Sponge)	C or I	23 lbs.	25 lbs.
Cake, Sponge	C or I	18 lbs.	40 lbs.
Cookies, Sugar	B	23 lbs.	30 lbs.
Dough, Bread or Roll (Lt.-Med.) 60% AR§	ED	45 lbs.*	45 lbs.*
Dough, Heavy Bread 55% AR§	ED	30 lbs.*	35 lbs.*
Dough, Pie	B & P	27 lbs.	35 lbs.
Dough, Thin Pizza 40% AR § † (max. mix time 5 min.)	ED	14 lbs.*	25 lbs.*
Dough, Med. Pizza 50% AR § †	ED	20 lbs.*	32 lbs.*
Dough, Thick Pizza 60% AR § †	ED	40 lbs.*	45 lbs.*
Dough, Raised Donut 65% AR	ED	15 lbs.**	25 lbs.**
Dough, Whole Wheat 70% AR	ED	40 lbs.*	45 lbs.*
Eggs & Sugar for Sponge Cake	B & C or I	12 lbs.	18 lbs.
Icing, Fondant	B	18 lbs.	25 lbs.
Icing, Marshmallow	C or I	3 lbs.	4½ lbs.
Shortening & Sugar, Creamed	B	24 lbs.	35 lbs.
Pasta, Basic Egg Noodle (max. mix time 5 min.)	ED	8 lbs.	15 lbs.

ABBREVIATIONS - AGITATORS SUITABLE FOR OPERATION

- B - Flat Beater
- C - Wing Whip
- D - Wire Whip
- ED - Dough Hook
- I - Wire Whip
- P - Pastry Knife

- * 1st Speed
- ** 2nd Speed
- *** 3rd Speed

NOTE: %AR (% Absorption Ratio) = Water weight divided by flour weight. Capacity depends on moisture content of dough. Above capacities based on 12% flour moisture at 70°F water temperature.

§ If high gluten flour is used, reduce above dough batch size by 10%.

† 2nd speed should never be used on 50% AR or lower products.

Use of ice requires a 10% reduction in batch size.

1 gallon of water weighs 8.33 lbs.

NOTE: Attachment hub should not be used while mixing.

Mixer Capacity Chart — HL600 & HL662

Recommended Maximum Capacities — dough capacities based on 70°F water and 12% flour moisture.

PRODUCT	AGITATORS SUITABLE FOR OPERATION	HL600	HL662
CAPACITY OF BOWL (QTS. LIQUID)		60	60
Egg Whites	D	2 qts.	—
Mashed Potatoes	B & C	40 lbs.	—
Mayonnaise (Qts. of Oil)	B or C or D	18 qts.	—
Meringue (Qty. of Water)	D	1½ qts.	—
Waffle or Hot Cake Batter	B	24 qts.	—
Whipped Cream	D or C	12 qts.	—
Cake, Angel Food (8-10 oz. cake)	C or I	45	—
Cake, Box or Slab	B or C	50 lbs.	75 lbs.
Cake, Cup	B or C	60 lbs.	70 lbs.
Cake, Layer	B or C	60 lbs.	70 lbs.
Cake, Pound	B	55 lbs.	75 lbs.
Cake, Short (Sponge)	C or I	45 lbs.	—
Cake, Sponge	C or I	36 lbs.	—
Cookies, Sugar	B	40 lbs.	50 lbs.
Dough, Bread or Roll (Lt.-Med.) 60% AR§	ED	80 lbs.**	90 lbs.**
Dough, Heavy Bread 55% AR§	ED	60 lbs.**	85 lbs.**
Dough, Pie	B & P	50 lbs.	60 lbs.
Dough, Thin Pizza 40% AR § † (max. mix time 5 min.)	ED	40 lbs.*	60*/40 lbs.
Dough, Med. Pizza 50% AR § V†	ED	70 lbs.*	90*/70 lbs.
Dough, Thick Pizza 60% AR § †	ED	70 lbs.**	90 lbs.**
Dough, Raised Donut 65% AR	ED	30 lbs.***	75 lbs.**
Dough, Whole Wheat 70% AR	ED	70 lbs.**	90 lbs.**
Eggs & Sugar for Sponge Cake	B & C or I	24 lbs.	—
Icing, Fondant	B	36 lbs.	—
Icing, Marshmallow	C or I	5 lbs.	—
Shortening & Sugar, Creamed	B	48 lbs.	50 lbs.
Pasta, Basic Egg Noodle (max. mix time 5 min.)	ED	30 lbs.	40 lbs.*

ABBREVIATIONS - AGITATORS SUITABLE FOR OPERATION

- B - Flat Beater
- C - Wing Whip
- D - Wire Whip
- ED - Dough Hook
- I - Wire Whip
- P - Pastry Knife

- * 1st Speed
- ** 2nd Speed
- *** 3rd Speed

NOTE: %AR (% Absorption Ratio) = Water weight divided by flour weight. Capacity depends on moisture content of dough. Above capacities based on 12% flour moisture at 70°F water temperature.

§ If high gluten flour is used, reduce above dough batch size by 10%.

† 2nd speed should never be used on 50% AR or lower products with the exception of the HL662.

Use of ice requires a 10% reduction in batch size.

1 gallon of water weighs 8.33 lbs.

NOTE: Attachment hub should not be used while mixing.

Mixer Capacity Chart — HL800 & HL1400

Recommended Maximum Capacities — dough capacities based on 70°F water and 12% flour moisture.

PRODUCT	AGITATORS SUITABLE FOR OPERATION	HL800	HL1400
CAPACITY OF BOWL (QTS. LIQUID)		80	140
Egg Whites	D	2 qts.	4 qts.
Mashed Potatoes	B & C	60 lbs.	100 lbs.
Mayonnaise (Qts. of Oil)	B or C or D	30 qts.	50 qts.
Meringue (Qty. of Water)	D	3 qts.	5 qts.
Waffle or Hot Cake Batter	B	32 qts.	—
Whipped Cream	D or C	16 qts.	30 qts.
Cake, Angel Food (8-10 oz. cake)	C or I	60	120
Cake, Box or Slab	B or C	100 lbs.	185 lbs.
Cake, Cup	B or C	90 lbs.	165 lbs.
Cake, Layer	B or C	90 lbs.	165 lbs.
Cake, Pound	B	100 lbs.	185 lbs.
Cake, Short (Sponge)	C or I	80 lbs.	150 lbs.
Cake, Sponge	C or I	65 lbs.	140 lbs.
Cookies, Sugar	B	60 lbs.	100 lbs.
Dough, Bread or Roll (Lt.-Med.) 60% AR§	ED	170 lbs.**	210 lbs.**
Dough, Heavy Bread 55% AR§	ED	140 lbs.**	175 lbs.**
Dough, Pie	B & P	75 lbs.	125 lbs.
Dough, Thin Pizza 40% AR § † (max. mix time 5 min.)	ED	85 lbs.*	135 lbs.*
Dough, Med. Pizza 50% AR § †	ED	155 lbs.*	190 lbs.*
Dough, Thick Pizza 60% AR § †	ED	155 lbs.**	190 lbs.**
Dough, Raised Donut 65% AR	ED	60 lbs.***	100 lbs.***
Dough, Whole Wheat 70% AR	ED	150 lbs.**	185 lbs.**
Eggs & Sugar for Sponge Cake	B & C or I	40 lbs.	75 lbs.
Icing, Fondant	B	65 lbs.	100 lbs.
Icing, Marshmallow	C or I	10 lbs.	20 lbs.
Shortening & Sugar, Creamed	B	65 lbs.	120 lbs.
Pasta, Basic Egg Noodle (max. mix time 5 min.)	ED	65 lbs.*	100 lbs.*

ABBREVIATIONS - AGITATORS SUITABLE FOR OPERATION

- B - Flat Beater
- C - Wing Whip
- D - Wire Whip
- ED - Dough Hook
- I - Wire Whip
- P - Pastry Knife

- * 1st Speed
- ** 2nd Speed
- *** 3rd Speed

NOTE: %AR (% Absorption Ratio) = Water weight divided by flour weight. Capacity depends on moisture content of dough. Above capacities based on 12% flour moisture at 70°F water temperature.

§ If high gluten flour is used, reduce above dough batch size by 10%.

† Requires a 50% reduction in batch size to mix in Speed 2 with 50% or less AR doughs.

Use of ice requires a 10% reduction in batch size.

1 gallon of water weighs 8.33 lbs.

NOTE: Attachment hub should not be used while mixing.

CREAMING OR RUBBING WITH THE B FLAT BEATER

When making cakes or similar products, the first step is normally rubbing or creaming the shortening. Start this work on first speed and complete it on second speed. If a very light consistency is desired, it may be beaten on third speed before adding more ingredients.

In most formulas, the second step is adding sugar. Most operators prefer to add sugar slowly while the mixer is operating in second or third speed. If you wish to add the sugar all at one time, complete the creaming of the shortening and then stop the machine. When adding the sugar, place it toward the center of the bowl. Start the machine in first speed for the first few turns around the bowl, then increase the speed to complete the operation. After all the sugar has been added, you may want to scrape down the bowl, if you don't have the optional bowl scraper. To scrape the bowl, first stop the mixer. After the beater has stopped, scrape down the sides of the bowl with a bowl scraper or spatula. This returns to the mixture any material which may have accumulated on the bowl sides above the beater shoulder. After scraping down the material, restart the mixer. Beat until smooth using a three speed. Be careful and do not overmix.

CAKES WITH A HIGH SUGAR CONTENT

Do not add the total amount of whole eggs to the batch at one time.

Darkening of the butter and sugar mix can also result if:

- You add the sugar before the shortening is creamed,
- You add the sugar too quickly to the creamed shortening, or
- You add more sugar than the creamed base can absorb.

When mixing whole eggs, it is unnecessary to separate the whites from the yolks. Add the eggs slowly and allow them to become thoroughly incorporated into the shortening base.

Flour and any leavening agent, such as baking powder, soda or special combinations of dry ingredients, may be sifted together. When incorporating dry ingredients, stop the mixer (wait for the beater to stop), scrape down the bowl if necessary, if you don't have the optional bowl scraper, and then add about $\frac{1}{3}$ of the flour and a portion of the milk or added moisture in any form. Resume mixing in first speed. When the flour is incorporated, add half of the remaining liquid and flour. When this is blended, add the remaining liquid and flour. Use only Stir or first speed while adding flour. If necessary, use the Stir speed during incorporation of the flour. This prevents raw flour from being thrown out of the mixer and avoids toughening of the mix by overmixing.

Exercise caution not to overmix the batch during or after the addition of the flour. Usually, by the time the flour is thoroughly incorporated, the mix is completed. Further beating is of no benefit and may cause toughening of the product. The time for beating and creaming is before adding the flour. After the flour and final moisture is added, do as little mixing as possible.



WHIPPING

Use either the D Wire Whip or the C Wing Whip for whipping operations. Although some special operations require other adaptations of the same general type of agitator, our discussion centers on the D Wire Whip and the C Wing Whip.

The D Wire Whip (sometimes called balloon or cage whip) is recommended for whipping cream. With today's marketing conditions, most raw or fresh cream whips well. All cream should be at least 36 to 48 hours old, and should be sufficiently high in butterfat to allow the air to be introduced by whipping. Cream should be cold, but not so cold that ice crystals are formed. When cream is too warm, it turns to butter when whipped. Start the mixer in first speed and gradually increase the speed finishing in third or fourth. The amount of total whipping will depend on the condition, temperature and butterfat content of the cream and the type of product being prepared. An experienced operator will recognize the point of greatest firmness or stiffness in the whipped product. Use care, the small diameter wires that produce good whipping can break if used to mix heavy product or if the whip is rapped on the side of the bowl to remove excess product.

The C Wing Whip may be used for cream whipping, but it is somewhat slower in operation. One of its principal uses in the kitchen is for whipping potatoes. Of course, whipped potatoes are cooked and then whipped while hot. The potatoes must be soft enough to break up easily by the action of the C Wing Whip in low speed. It is not advisable to whip potatoes in fourth speed without using a splash cover. If other ingredients (hot milk, butter or other enriching material) are added, use Stir speed. The C Wing Whip is excellent for whipping butter.

The C Wing Whip may also be used for mixing salad dressing and light mayonnaise. Since it is an aerating type whip, it reaches its greatest efficiency at the higher speeds.

The D Wire Whip is generally used for eggs. When you whip only egg whites, begin in first speed. When the material begins to expand, progress to second speed. Due to the expansion of the product from the incorporation of air, bowl capacity is limited by the volume of the final product, not by the amount of liquid ingredients at the beginning.

When egg whites are whipped, they are generally finished in high speed. When adding sugar to make a meringue, add the sugar at slow speed and then whip briefly in third speed.

Over-whipping will result in a refining action which liberates air. Stop the mixer as soon as a dry-appearing peak is reached.

When whipping eggs, either whites or whole eggs, it is important to have the bowl and the agitator completely free of any trace of shortening or other oily material. The slightest amount of fat will prevent proper incorporation of air. See **CLEANING NEW MIXER BOWLS AND ACCESSORIES**. In some kitchens and bakeries, it has become general practice to keep certain bowls only for this purpose.

You may also use the C Wing Whip for whipping eggs or egg whites. However, the results are somewhat slower than produced by the D Wire Whip.



MAYONNAISE

The C Wing Whip, because of its strength, high efficiency and durability when used on larger mixers, is most commonly used for making mayonnaise. However, the D Wire Whip may be preferred when making very light batches or when using step-down bowls.

When you do not need a high emulsion, you may use the B Flat Beater. The B Flat Beater may be used for French or other thin types of salad dressings. The C Wing Whip can also provide satisfactory results by operating the machine at a slow speed.

Because of the great variation in types of mayonnaise and a still wider range of salad dressings known under other names, we will not supply a specific mayonnaise formula. All formulas, however, require the introduction of liquid ingredients, the most important of which is vegetable oil. This may be corn oil, peanut oil, soybean oil, palm oil, safflower oil or several others. You must add the oil slowly, and the operator must pay close attention.

When making mayonnaise, eggs are first thoroughly whipped, then spices, flavoring or other ingredients are added at slow speed. These may have been previously mixed together, perhaps with a portion of vinegar or other mild acid. After blending these ingredients, the mixer may be operated in third speed (or fourth). Add the oil very slowly over an interval of 10 to 20 minutes. Add vinegar or vinegar and water toward the end of the interval when oil can be added. You may wish to stop the mixer (wait for the beater to stop), then scrape the sides of the bowl to return any splashed materials to the batch, if you don't have the optional bowl scraper. Start the mixer on slow speed, then advance to medium for a short period of mixing.

The times given are approximate and not based on any particular formula. However, do not continue beating or mixing after adding the last of the vinegar.

Attachments and Accessories

Several valuable time and labor saving attachments and accessories are available for use with Hobart mixers. These tools will extend your usage of the mixer and enhance your operation by efficiently producing additional consistent, uniform products. Thoroughly clean all parts which come in contact with food both before and after use.

9" VEGETABLE SLICER

The 9" Vegetable Slicer attachment allows you to prepare many additional foods with your Hobart mixer. The standard knife and shaft is adjustable to provide variation in slice thickness from a maximum of about $\frac{5}{8}$ " to wafer thin. Thicker settings are used for slicing vegetables for salads or cole slaw, slicing potatoes for German (cottage fries) or American fried potatoes, slicing cucumbers, bananas, nuts, apples, etc.

The 9" VS is easily adapted for grating or shredding processes by removing the knife and shaft and using the shaft with the wheel, called a plate holder. One grater plate and four shredder plates (with hole sizes of $\frac{3}{32}$, $\frac{3}{16}$, $\frac{5}{16}$ and $\frac{1}{2}$ ") are used for fine grating or fine to coarse shredding. The most coarse shredder plate ($\frac{1}{2}$ ") is used for slaw, cutting soup stock, salad blends or hash brown potatoes. Experience with the unit will suggest many other products to the operator. The medium and fine shredder plates are for finer cuts on carrots, mushrooms or cabbage hearts for salad or quick cooking uses. Medium shredder plates are also used for shredding processed cheese for a topping when desired. The grater plate is used for natural hard cheeses for pizza, grating hard vegetables, spices, and crumbling dried bread.

Many different products can be prepared with the 9" Vegetable Slicer - in kitchens, bakeries or delicatessen operations. As a mixer attachment, the vegetable slicer should operate at second or third speed on the HL120, HL200, HL300 and HL400, third or fourth speed on the HL600 and dedicated speeds on the HL662 mixer.

Never use the highest speed setting when shredding cheese.

The 9" VS easily disassembles for cleaning.

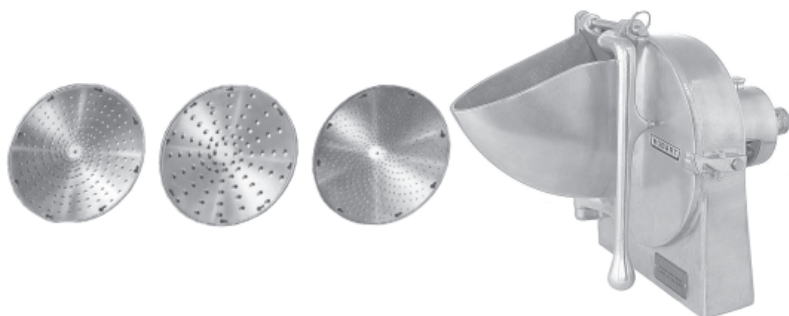

SHREDDER AND GRATER PLATES 9" VS

9" VEGETABLE SLICER

MEAT CHOPPER ATTACHMENT

The Meat Chopper Attachment allows you to prepare many additional foods with your Hobart mixer. A plate having $\frac{1}{8}$ " holes comes with the Meat Chopper Attachment when shipped from the factory. Other plates are available with hole sizes $\frac{5}{64}$, $\frac{3}{16}$, $\frac{1}{4}$, $\frac{3}{8}$, $\frac{1}{2}$, $\frac{5}{8}$ and $\frac{11}{16}$ " for fine to coarse chopping. The results are the same as produced by Hobart commercial meat choppers. Operate Meat Chopper Attachments in slower speeds.

The feed pan should be kept in place in the cylinder for ease of feeding. Cut meat into strips and feed it into the chopper using the feed stomper only as needed. Substances that could become packed tight in the chopper like **bread crumbs are not recommended**. If material in the cylinder stalls the mixer, push the STOP button at once. DO NOT attempt to restart at a slower speed. Remove the adjusting ring, knife, plate and worm and clear the obstruction.

Always keep the drain hole on both the Attachment Hub and Meat Chopper clean, clear and free of obstruction.



MEAT CHOPPER ATTACHMENT

SPLASH COVER AND BOWL EXTENSION RING

Splash Covers and Bowl Extension Rings provide a means for reducing splashing for certain mixes at higher speeds. Splash covers fit under the Bowl Guard. The stainless steel Bowl Extension Ring is also available.

Splash Covers and Bowl Extensions, while convenient accessories, should not be used to increase the mixing capacity beyond the recommended maximum. The best functioning of Hobart mixers requires room at the top of the bowl for aeration and manipulation. Follow the Hobart Mixer Capacity Chart of the best quality of mix.

Splash Covers on larger mixers have a smaller diameter opening at the top due to their inverted cone shape. Overloading the mixer while a splash cover is in use reduces aeration because of restriction in the area where air enters the batch.



SPLASH COVER



BOWL EXTENSION RING

INGREDIENT CHUTE

The Ingredient Chute can be attached to the Wire Cage on the Bowl Guard. The Ingredient Chute allows ingredients to be added to the bowl while the mixer is mixing.

BOWL SCRAPER ATTACHMENT

The mixer Bowl Scraper Attachment is available to scrape the sides of the bowl as the agitator rotates to re-introduce material into the mixture.



INGREDIENT CHUTE



BOWL SCRAPER ATTACHMENT

BOWL TRUCK

Bowl Trucks or dollies provide convenience, save time, and reduce effort in handling large batches. Use a Bowl Truck for any batches over 50 pounds. Remove heavy batches of dough or batter from the mixer by unlocking the bowl and lowering the bowl to the Bowl Truck. Then, carefully roll the truck away to make room for the next batch. Move the material to another location where it is to be used, or refrigerate between mixing and further processing. Bowl Trucks save time, reduce handling, and improve work flow. They are valuable tools in a work place.



BOWL TRUCK

— NOTES —

NOTES

Backing Up Your Purchase Dependable Hobart Service

Should your Hobart mixer, attachments or accessories ever require service, it's good to know that more than 1600 factory trained technicians in more than 200 Hobart service facilities nationwide, can keep your mixer working like new.

For ready reference, write down your mixer model and serial numbers here. Should a question or problem arise that this booklet or the instructions you received with the machine cannot answer, expert Hobart assistance is as close as your telephone.



Or, contact Hobart on the internet . . .

www.hobartcorp.com

Model No. _____

Serial No. _____

Hobart Service Location _____

Telephone Number: _____

WARNING

ELECTRICAL AND GROUNDING CONNECTIONS
MUST COMPLY WITH THE APPLICABLE
PORTIONS OF THE NATIONAL ELECTRICAL
CODE AND/OR OTHER LOCAL ELECTRICAL CODES.

SWITCH STATE TABLE		
SWITCH	CONDITION	RESULT
BOWL SWITCH	OPEN	BOWL OUT MIX POSITION
	CLOSED	BOWL IN MIX POSITION
BOWL GUARD	OPEN	CAGE OPEN
	CLOSED	CAGE IN MIX POSITION

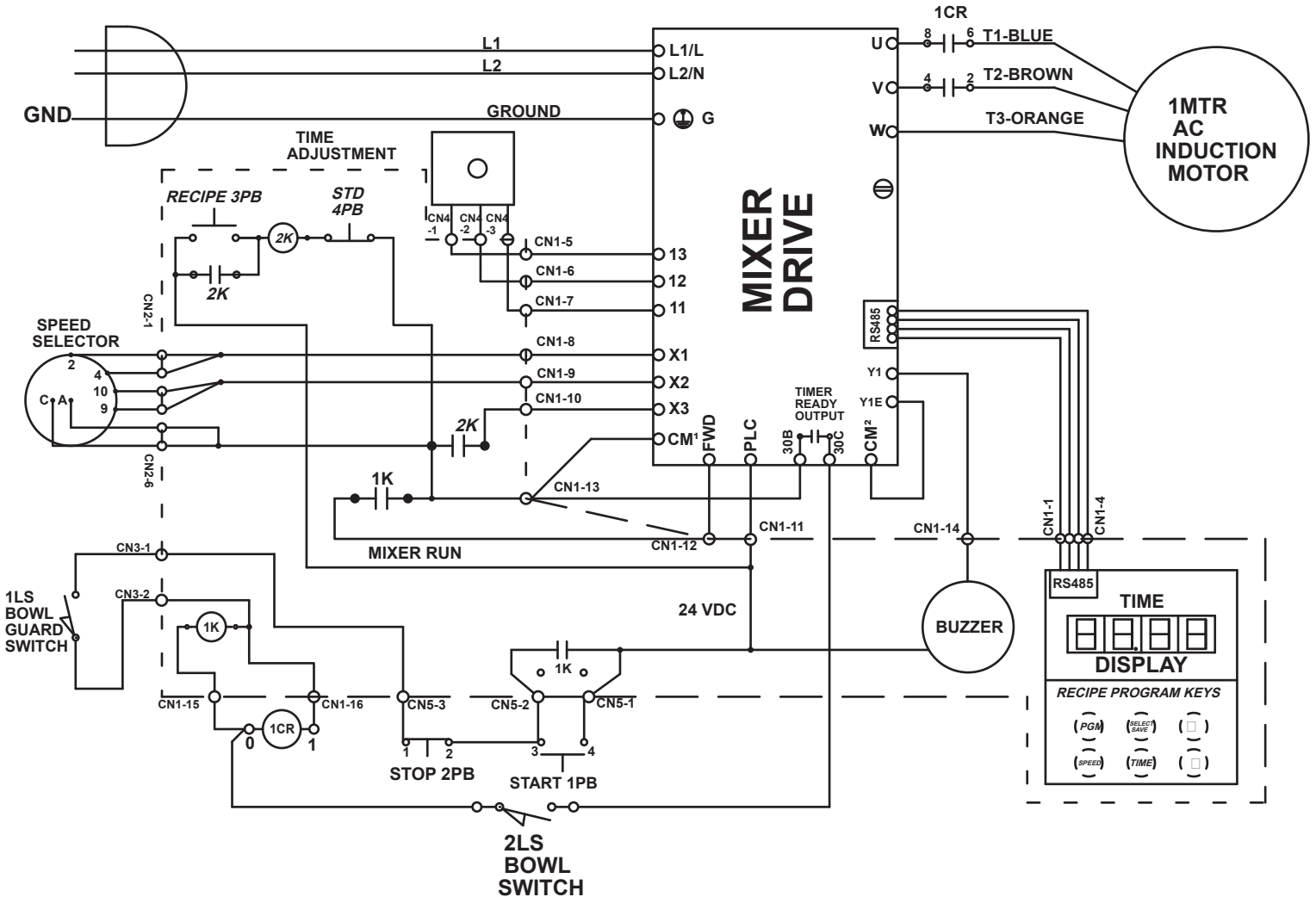

SYMBOL DEFINITIONS

- | | |
|---|--|
| <ul style="list-style-type: none"> CONTACT-NORMALLY OPEN (N.O.) CONTACT-NORMALLY CLOSED (N.C.) MOTOR GND GROUND LS LIMIT SWITCH - N.O. PB PUSH BUTTON-STOP (N.C.) PB PUSH BUTTON-START (N.O.) | <ul style="list-style-type: none"> CR CONTROL RELAY COIL INSEPARABLE CONNECTION SEPARABLE CONNECTION HEAVY LINE DENOTES EXTERNAL WIRING LIGHT LINE DENOTES FIXED PREWIRING (PRINTED CIRCUIT WIRING OR OTHER). DASHED LINE DENOTES BOUNDARY OF PRINTED WIRING BOARD <i>STD</i> SYMBOLS AND LABELS IN ITALICS <i>4PB</i> USED ON RECIPE TIMER ONLY |
|---|--|

**HL200 MIXER
ELECTRICAL DIAGRAM
100-120/50/60/1
200-230/50/60/1**

DERIVED FROM F34936A

AI 2721

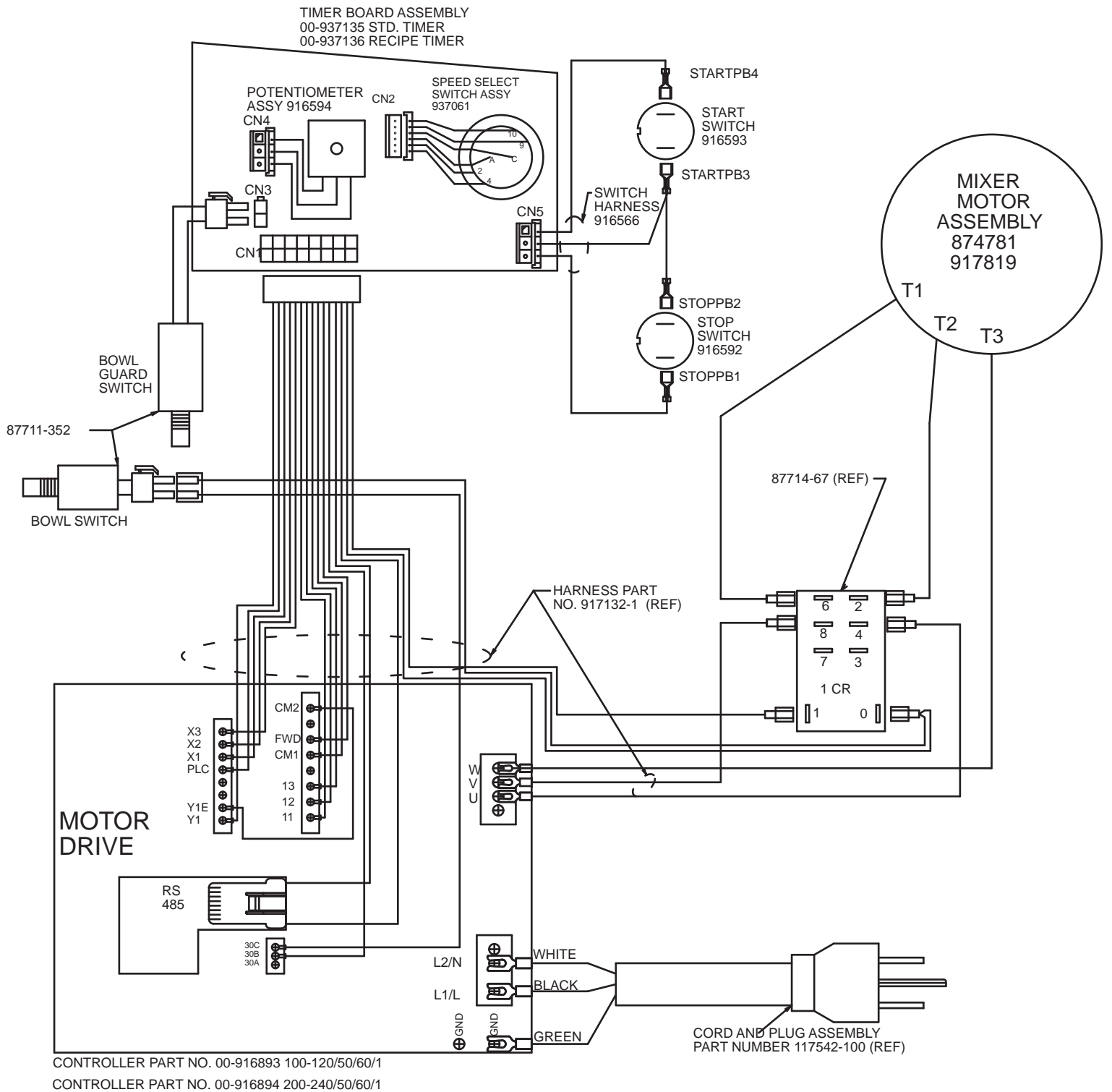

DERIVED FROM 477208-27 REV D

HL200 CONNECTION DIAGRAM

AI2720



CATALOG OF REPLACEMENT PARTS



LEGACY MIXER

HL120	ML-134459
HL200	ML-134455
HL200C	ML-134456
HL200	ML-134457
HL200	ML-134458

A product of HOBART 701 S. RIDGE AVENUE TROY, OHIO 45374-0001

FORM 43177 (May 2009)

Table of Contents

5	CONTROL PANEL
6	ELECTRICAL COMPONENTS
7	ATTACHMENT HUB
9	BASE AND PEDESTAL
11	FLOOR BASE AND PEDESTAL (ML-134458)
12	BOWL SUPPORT
13	TRANSMISSION CASE AND MOTOR
15	TRANSMISSION
17	PLANETARY
19	BOWL AND BOWL GUARD
21	AGITATORS AND ACCESSORIES
23	MIXER TABLE (ML-134299)
24	WIRING HARNESS

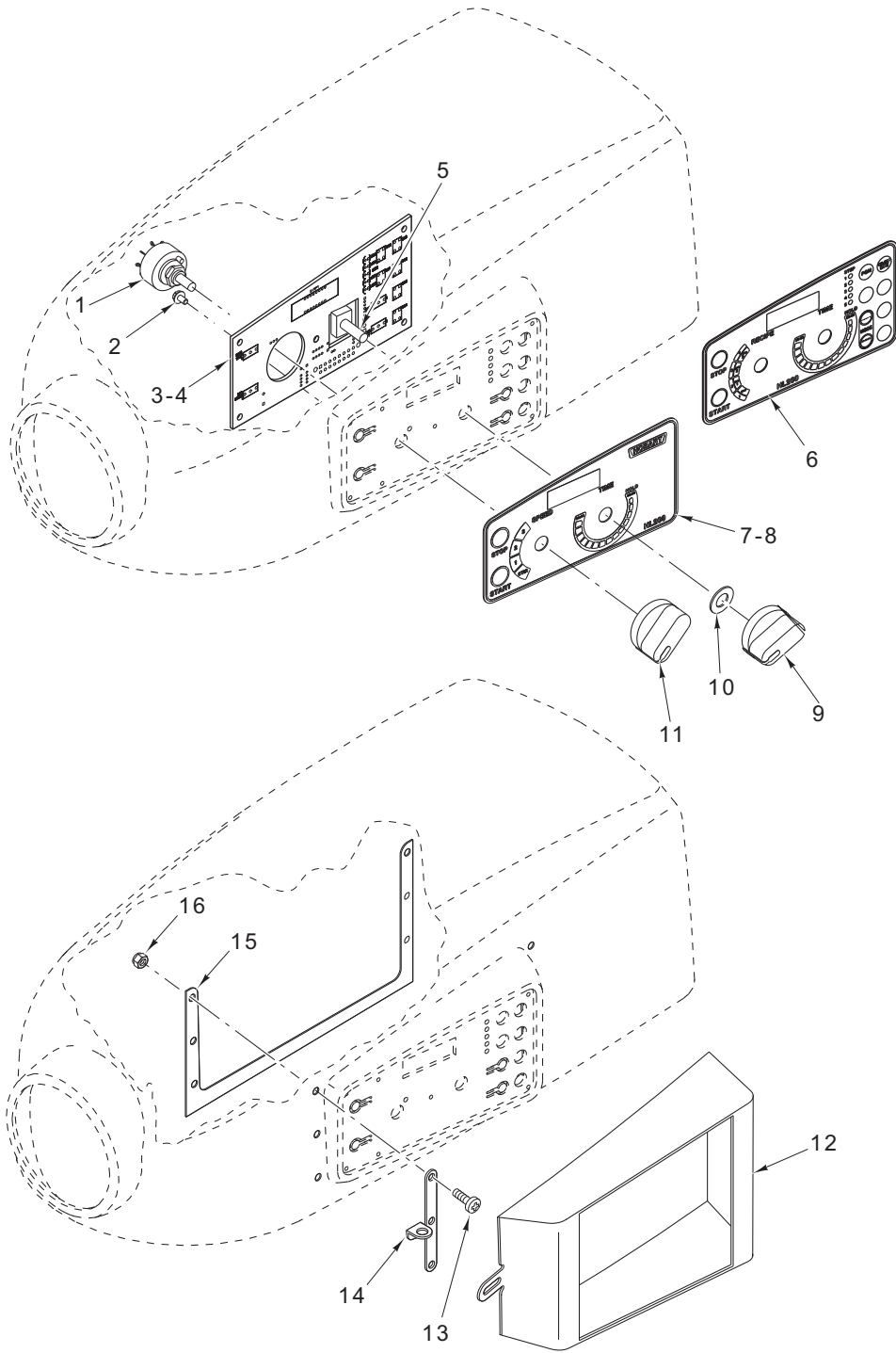

PL-58126

CONTROL PANEL

CONTROL PANEL

ILLUS.	PART NO.	NAME OF PART	AMT.
PL-58126			
1	00-874831	Switch – Speed Selector Assy.	1
2	SD-039-23	Self-Tapping Screw 6-32 x 1/4 Hex Washer Hd., Type RL.....	5
3	00-917212	PCB Assy.	1
4	00-917213	PCB Assy. – Recipe Timer (ML-134457)	1
5	00-916594	Potentiometer Assy.	1
6	00-874811	Overlay (With Recipe Timer) (ML-134457).....	1
7	00-874881	Overlay (Without Recipe Timer) (ML-134455, ML-134456, ML-134457, & ML-134458)	1
8	00-874868	Overlay (ML-134459).....	1
9	00-874809	Knob	1
10	WS-031-55	Washer.....	1
11	00-874809	Knob	1
12	00-874921	Cover – Weldment (ML-134456).....	1
13	SC-128-62	Mach. Screw 10-24 x 1/2 Tx. Button Hd. (ML-134456)	6
14	00-874923	Latch (ML-134456)	1
15	00-874931	Plate – Backer (ML-134456).....	1
16	NS-038-13	Lock Nut 10-24 Hex (ML-134456)	6

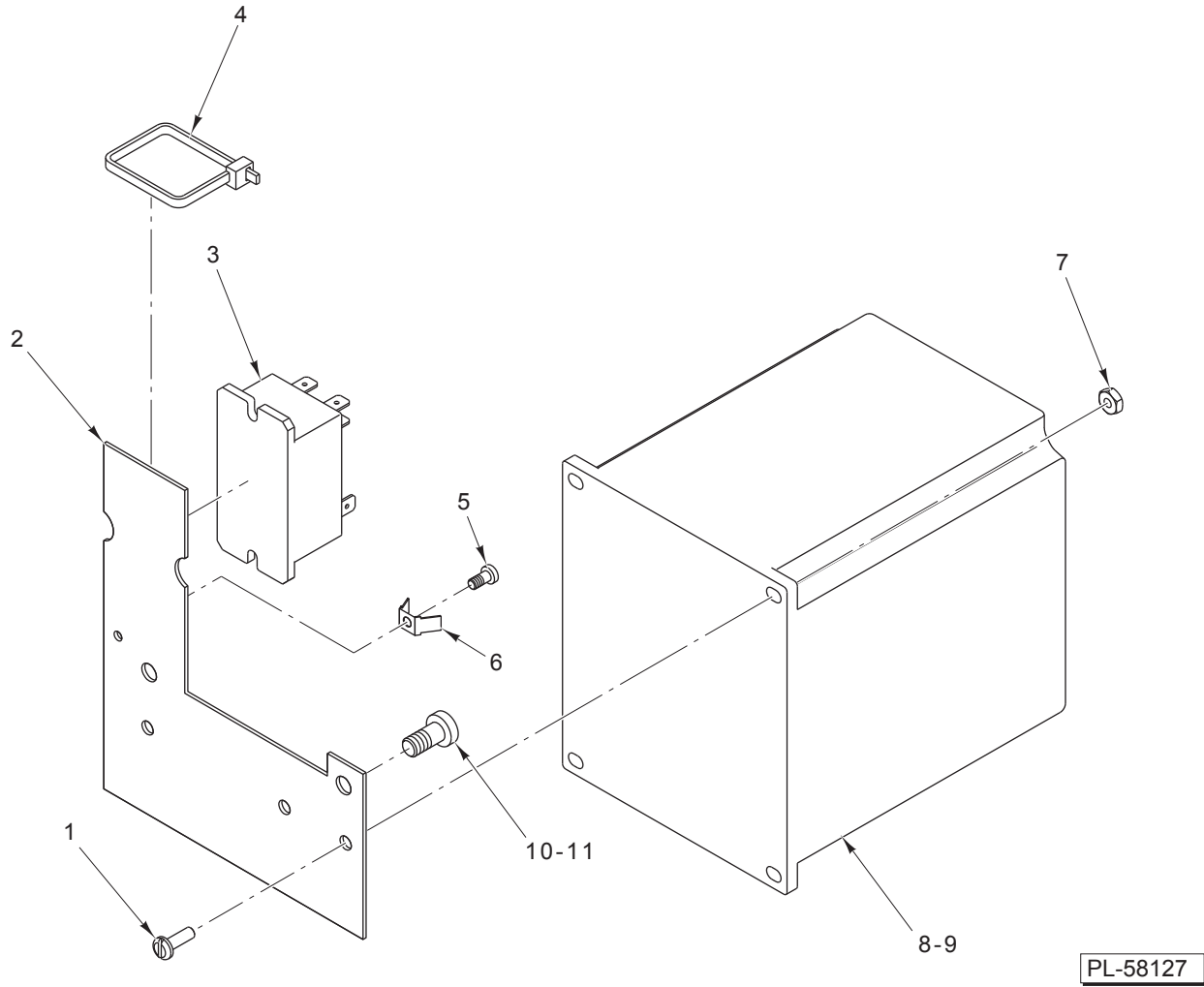

ELECTRICAL COMPONENTS

ILLUS.	PART NO.	NAME OF PART	AMT.
PL-58127			
1	SC-018-38	Mach. Screw 8-32 x 1/2 Slotted Pan Hd.....	2
2	00-874763	Bracket – Controller.....	1
3	00-087714-042-5	Relay (2 Pole, 30 Amp.).....	1
4	00-539847	Tie – Cable (8 In.).....	1
5	SD-015-37	Self-Tapping Screw 6-32 x 1/4 Phil. Pan Hd., Type TT.....	1
6	00-065890-00090	Terminal (2-Tab).....	1
7	NS-009-12	Mach. Nut 8-32 Hex.....	2
8	00-916893	Controller – GE Low Voltage.....	1
9	00-916894	Controller – GE High Voltage.....	1
10	SC-114-80	Mach. Screw 1/4-20 x 3/8 Slotted Pan Hd.	2
11	SC-089-01	Cap Screw 1/4-20 x 1/2 Hex Socket Hd. (ML-134308 & ML-134331).....	2

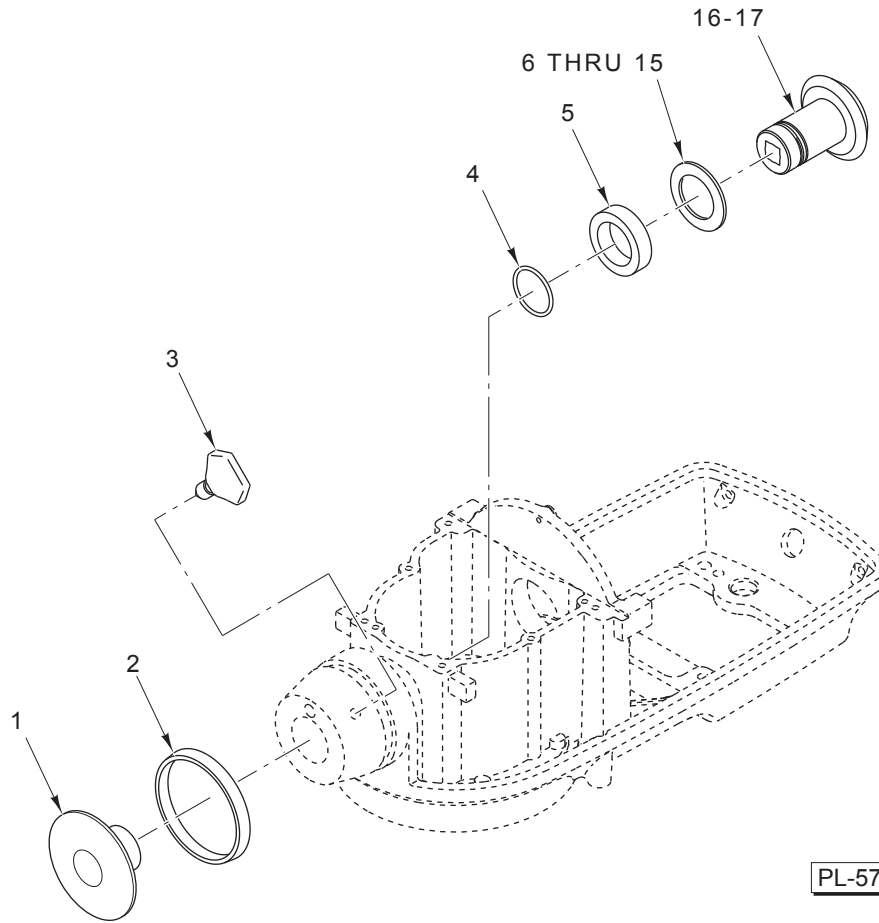

ATTACHMENT HUB

ILLUS.	PART NO.	NAME OF PART	AMT.
PL-57679			
1	00-917221	Plug – Attachment.....	1
2	00-874925-00004	Seal – Neopreme.....	1
3	00-108197-00001	Screw – Thumb 1 ¹ / ₈	1
4	OR-001-03	O-Ring – Quad.....	1
5	00-874837	Spacer	1
6	00-012746-00005	Washer – Thrust (0.080).....	AR
7	00-012746-00006	Washer – Thrust (0.106).....	AR
8	00-012746-00007	Washer – Thrust (0.092).....	AR
9	00-012746-00008	Washer – Thrust (0.086).....	AR
10	00-012746-00009	Washer – Thrust (0.098).....	AR
11	00-012746-00010	Washer – Thrust (0.112).....	AR
12	00-012746-00012	Washer – Thrust (0.119).....	AR
13	00-012746-00013	Washer – Thrust (0.121).....	AR
14	00-012746-00016	Washer – Thrust (0.129).....	AR
15	00-012746-00019	Washer – Thrust (0.115).....	AR
16	00-435065-00002	Bevel Gear Seal Assy. (Incls. Item 17).....	1
17	PL-003-17	Plug – Expansion.....	1

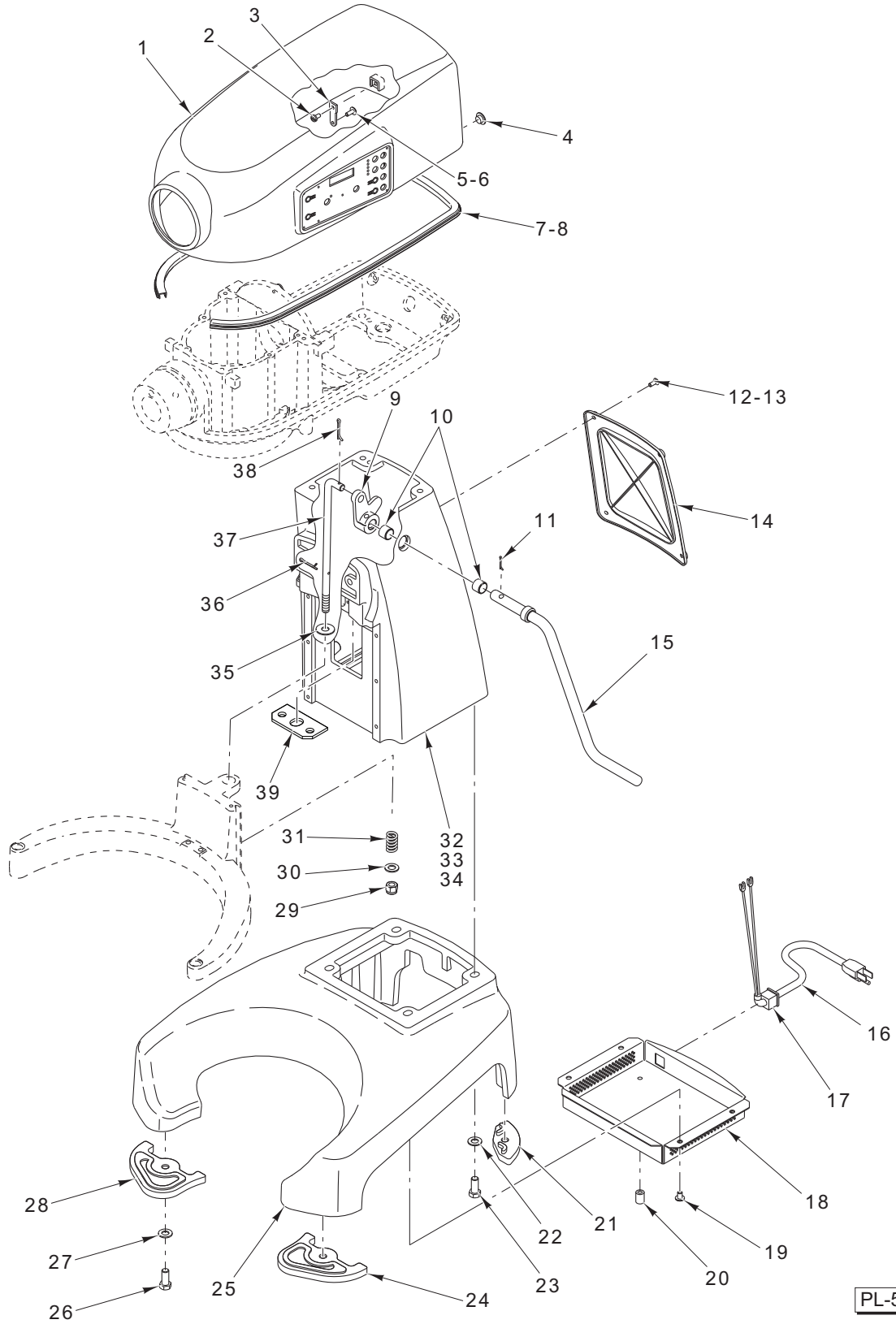

PL-58131

BASE AND PEDESTAL

BASE AND PEDESTAL

ILLUS. PL-58131	PART NO.	NAME OF PART	AMT.
1	00-916262	Cover – Top.....	1
2	SD-024-01	Self-Tapping Screw 10-24 x 3/8 Slotted Pan Hd., Type TT	2
3	00-874829	Tab – Cover Mounting.....	2
4	00-874857	Plug – Hole	1
5	SC-066-20	Mach. Screw 10-32 x 1/2 Phil. Truss Hd. (SST).....	2
6	SC-128-81	Mach. Screw 10-32 x 1/2 Tx. Button Hd. (ML-134456)	2
7	00-874925-00001	Seal – Neopreme.....	1
8	00-874925-00002	Seal – Neopreme.....	1
9	00-874756	Arm – Bowl Lift.....	1
10	00-479510	Bushing – Bowl Lift	2
11	PS-004-15	Pin – Spirol (1/4).....	1
12	SC-015-34	Mach. Screw 10-24 x 1/2 Slotted Oval Hd.....	4
13	SC-128-75	Mach. Screw 10-24 x 5/8 Flat. Hd. (SST) (ML-134456)	4
14	00-917231	Cover – Pedestal (Back).....	1
15	00-874745-00002	Handle & Bushing – Bowl Lift	1
16	00-874833-00001	Cord & Plug Assy. (120 V.).....	1
17	FE-026-34	Relief – Strain (Electrical) (ML-134456).....	1
18	00-874760	Cover – Controller (ML-134456).....	1
19	SC-114-80	Mach. Screw 1/4-20 x 3/8 Phil. Pan Hd. (ML-134455, & ML-134456)	4
20	FE-026-43	Bushing – Electric Snap (ML-134455, ML-134457, & ML-134459)	1
21	00-874879	Pad – Rear (ML-134456).....	2
22	WS-018-24	Washer (ML-134456).....	4
23	SC-118-11	Cap Screw 3/8-16 x 7/8 Hex Hd. (ML-134456).....	4
24	00-874896	Pad – Front (RH) (ML-134456).....	1
25	00-874720-00002	Base (ML-134456).....	1
26	SC-118-12	Cap Screw 3/8-16 x 3/4 Hex Hd. (ML-134456).....	4
27	WS-018-34	Washer (ML-134456).....	4
28	00-874878	Pad – Front (LH) (ML-134456)	4
29	NS-036-15	Stop Nut 3/8-24 Special.....	1
30	WS-006-26	Washer.....	1
31	00-012782	Spring	1
32	00-874723-00002	Pedestal.....	1
33	00-874925-00003	Seal – Neopreme.....	1
34	SC-100-08	Mach. Screw 1/4-20 x 3/8 Hex Washer Hd.	2
35	WS-006-26	Washer.....	1
36	PC-003-55	Cotter Pin 1/8.....	1
37	00-874748	Rod – Bowl Lift.....	1
38	PC-003-55	Cotter Pin 1/8.....	1
39	00-874870	Plate – Spring Bowl Yoke.....	1
	00-917167	Barrier – Steam.....	1

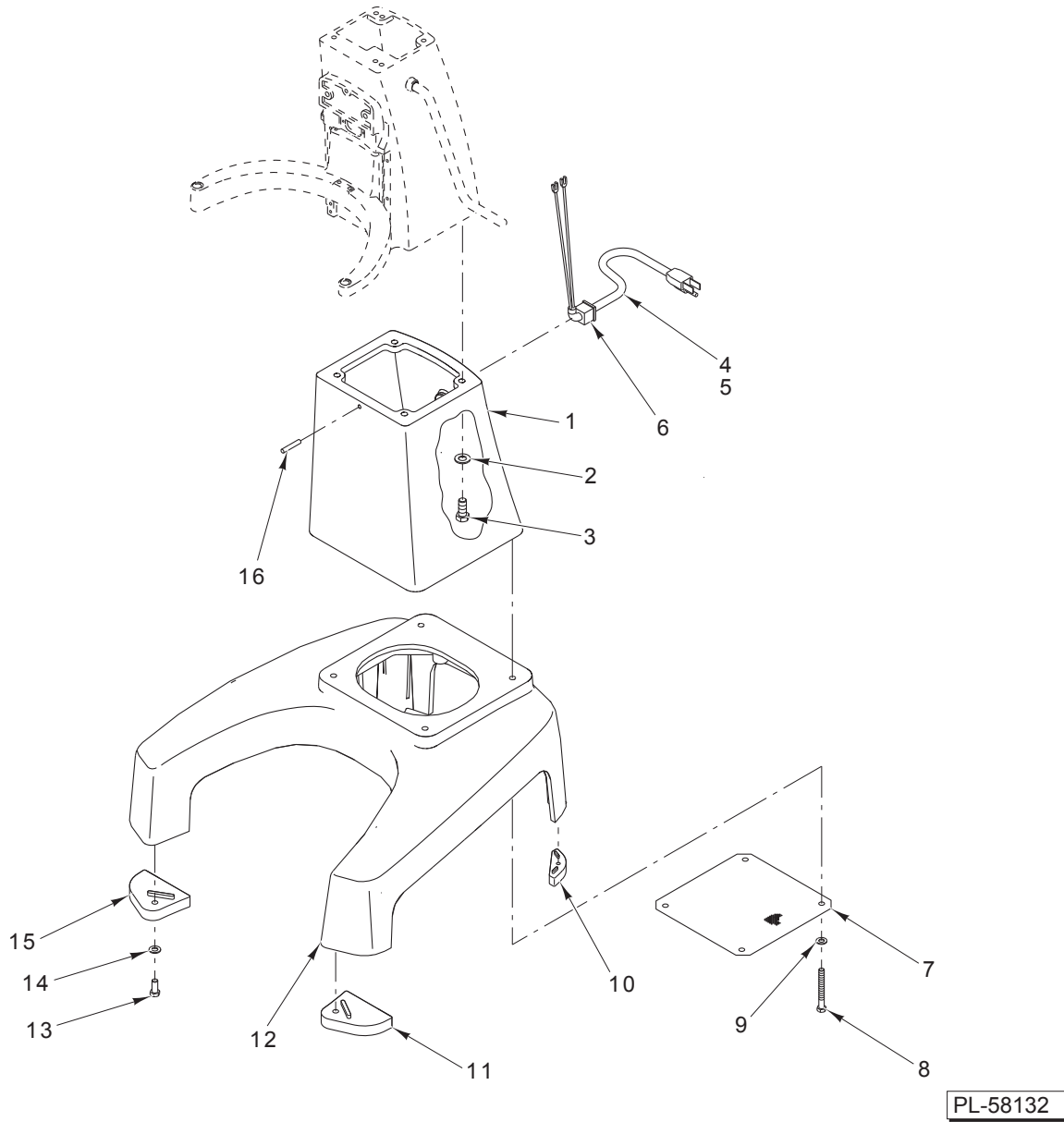

FLOOR BASE AND PEDESTAL (ML-134458)

FLOOR BASE AND PEDESTAL (ML-134458)

ILLUS.	PART NO.	NAME OF PART	AMT.
PL-58132			
1	00-916548-00002	Block – Riser.....	1
2	WS-018-24	Washer.....	8
3	SC-118-10	Cap Screw 3/8-16 x 1 Hex Hd.....	4
4	00-874833-00001	Cord & Plug Assy. (120 V.).....	1
5	00-117542-00001	Cord & Plug.....	1
6	FE-022-84	Relief – Strain (Electrical).....	1
7	00-916549	Screen – Air Floor.....	1
8	SC-124-91	Cap Screw 3/8-16 x 2 1/2 Hex Hd.....	4
9	WS-018-24	Washer.....	8
10	00-916309	Pad – Rear.....	2
11	00-916308	Pad – Front (RH).....	1
12	00-916213-00004	Base.....	1
13	SC-118-12	Cap Screw 3/8-16 x 3/4 Hex Hd.....	4
14	WS-018-34	Washer.....	4
15	00-916307	Pad – Front (LH).....	1
16	PG-005-25	Pin – Grooved.....	1

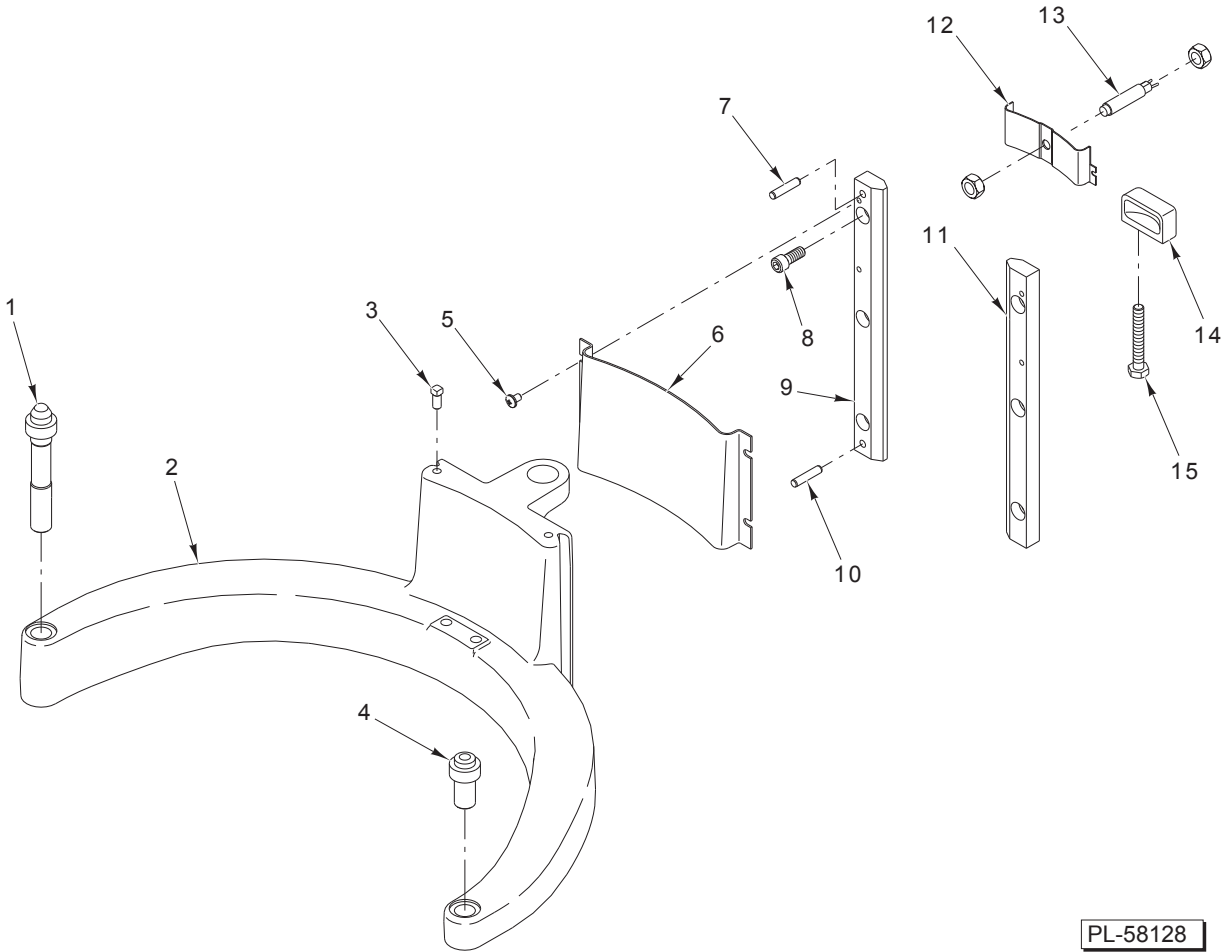

PL-58128

BOWL SUPPORT

ILLUS.	PART NO.	NAME OF PART	AMT.
PL-58128			
1	00-874726	Pin – Bowl (LH).....	1
2	00-874841-00002	Support – Bowl	1
3	SC-129-22	Set Screw 1/4-20 x 1/4 Sq. Hd. Cup Pt.....	2
4	00-874727	Pin – Bowl (RH)	1
5	SC-122-59	Mach. Screw 8-32 x 1/4 Phil. Pan Hd. (SST)	4
6	00-874742	Apron	1
7	00-011800-00187	Dowel.....	2
8	SC-040-09	Cap Screw 1/4-20 x 1 1/4 Hex Socket Hd.....	6
9	00-874738-00001	Slideway – Bowl Lift (LH).....	1
10	00-011800-00187	Dowel.....	1
11	00-874738-00002	Slideway – Bowl Lift (RH)	1
12	00-874884	Cover – Bowl Interlock.....	1
13	00-087711-00352	Switch – Reed.....	1
14	00-874842	Hold Down – Bowl (Rear)	1
15	SC-062-69	Cap Screw 1/4-20 x 1 3/4 Hex Hd.....	2
	PB-004-97	Cap	4

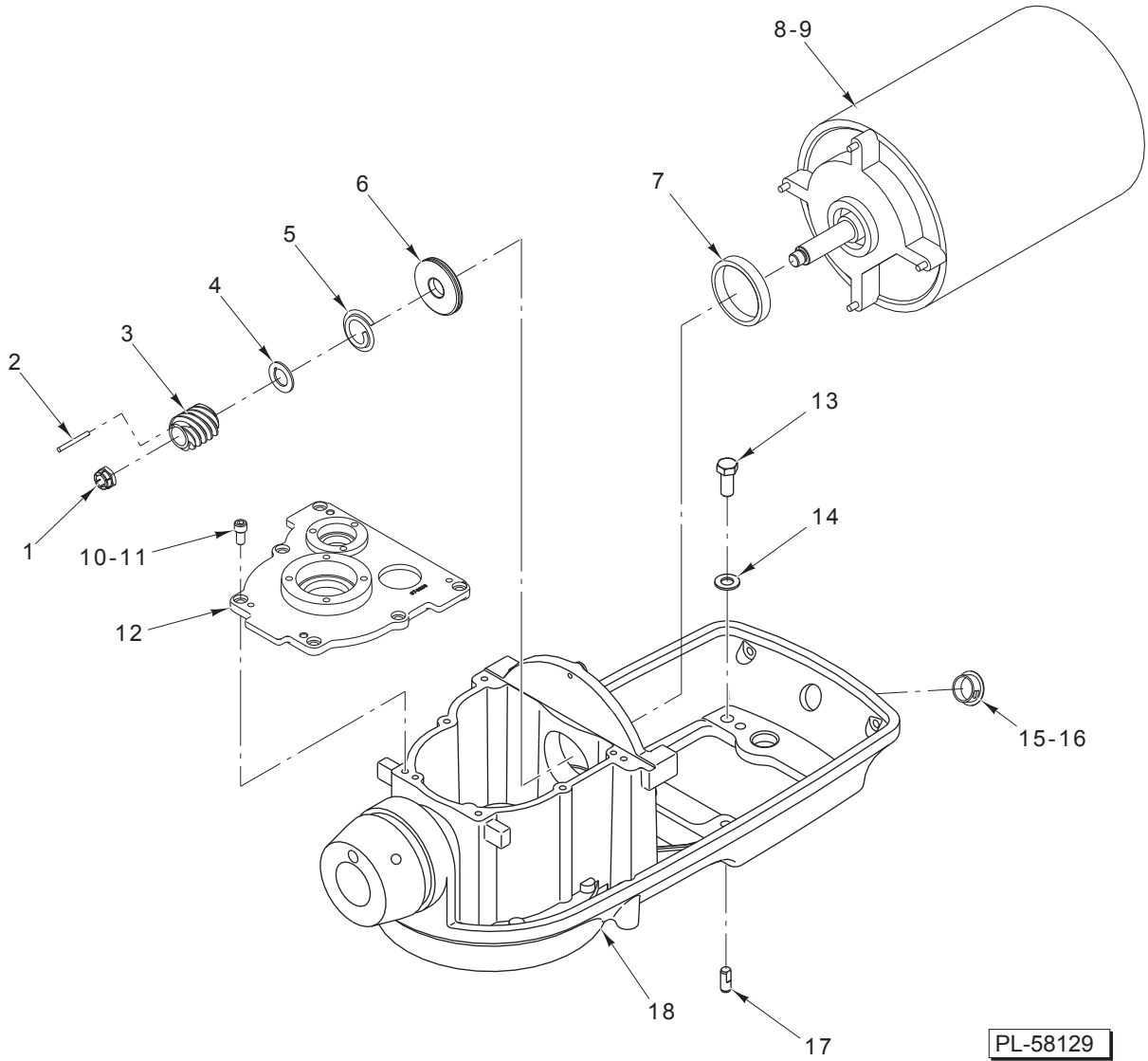

PL-58129

TRANSMISSION CASE AND MOTOR

ILLUS.	PART NO.	NAME OF PART	AMT.
	PL-58129		
1	NS-032-23	Lock Nut $\frac{7}{16}$ -20 Special	1
2	00-012430-00004	Key $\frac{1}{8}$ x $\frac{1}{8}$ x $1\frac{1}{4}$	1
3	00-291221	Worm – Gear 60 Cycle	1
4	00-012754	Washer	1
5	00-012757	Absorber – Shock Spring	1
6	00-874820	Deflector – Grease (LH)	1
7	00-916445	Bushing – Motor Mounting	1
8	00-917810	Motor (100-120 V.)	1
9	00-874634	Motor (200-240 V.)	1
10	SC-089-01	Cap Screw $\frac{1}{4}$ -20 x $\frac{1}{2}$ Hex Socket Hd. (HL200)	6
11	SC-089-02	Cap Screw $\frac{1}{4}$ -20 x $\frac{3}{4}$ Hex Socket Hd. (HL120)	6
12	00-874755	Cover – Transmission	1
13	SC-118-11	Cap Screw $\frac{3}{8}$ -16 x $\frac{7}{8}$ Hex Hd.	4
14	WS-018-24	Washer	4
15	00-874857	Plug	1
16	00-874876	Plug – Cupped Expansion	1
17	00-270776	Dowel	2
18	00-917805	Transmission Case – Lower	1
	00-917983	Label Assy. – Warning Shield	1
	00-438131-00187	Label – Warning	1
	SD-039-23	Self-Tapping Screw 6-32 x $\frac{1}{4}$ Hex Washer Hd.	2

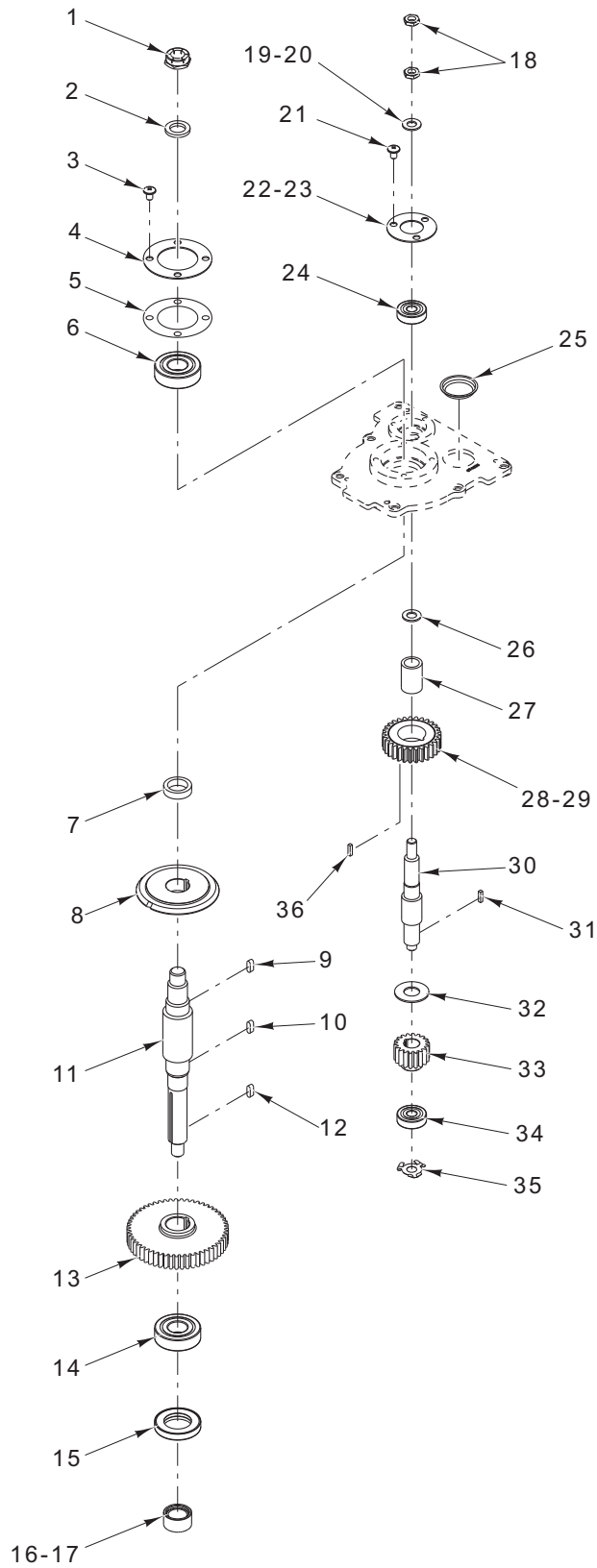

PL-58130

TRANSMISSION

TRANSMISSION

ILLUS. PL-58130	PART NO.	NAME OF PART	AMT.
1	NS-032-37	Lock Nut ⁵ / ₈ -18 Special	1
2	WS-031-41	Washer.....	1
3	SC-114-80	Mach. Screw ¹ / ₄ -20 x ³ / ₈ Phil. Pan Hd.	4
4	00-874787	Retainer – Planetary Bearing.....	1
5	00-874795	Gasket – Bearing.....	1
6	BB-005-34	Bearing – Ball	1
7	00-874793	Spacer – Planetary	1
8	00-124733-00002	Gear – Bevel (46T, 14P).....	1
9	00-874873-00001	Key.....	1
10	00-874873-00002	Key.....	1
11	00-874635	Shaft – Planetary	1
12	00-012430-00017	Key ¹ / ₈ x ¹ / ₈ x 2 ⁷ / ₁₆	1
13	00-874778	Gear (55T, 14P).....	1
14	BB-020-06	Bearing – Ball Fafnir 204K.....	1
15	00-114695	Seal – Oil	1
16	00-437342	Spacer – Bearing	1
17	00-067500-00078	O-Ring	1
18	00-012710	Nut – Retaining	2
19	WS-006-36	Washer (ML-134455, ML-134456, ML-134457, & ML-134458).....	1
20	WS-008-13	Washer (ML-134459).....	1
21	SC-114-80	Mach. Screw ¹ / ₄ -20 x ³ / ₈ Phil. Pan Hd.	3
22	00-874788	Retainer – Bearing.....	1
23	BB-005-02	Bearing – Ball	1
24	BB-005-01	Bearing – Ball Fafnir 200K.....	1
25	00-064871	Plug – Friction.....	1
26	WS-006-26	Washer.....	1
27	00-916962	Spacer – Gear	1
28	00-917797	Gear – Worm (100-120 V.).....	1
29	00-874934	Gear – Worm (29T) (200-240 V.).....	1
30	00-916961	Shaft – Worm Wheel.....	1
31	00-012430-00024	Key ¹ / ₈ x ¹ / ₈ x 1 ¹ / ₂	1
32	WS-006-26	Washer (ML-134308, ML-134331, & ML-134312).....	1
33	00-874777	Gear (18T, 14P).....	1
34	BB-005-01	Bearing – Ball Fafnir 200K.....	1
35	SL-002-08	Spring – Loading.....	1
36	00-012430-00024	Key ¹ / ₈ x ¹ / ₈ x 1 ¹ / ₂	1

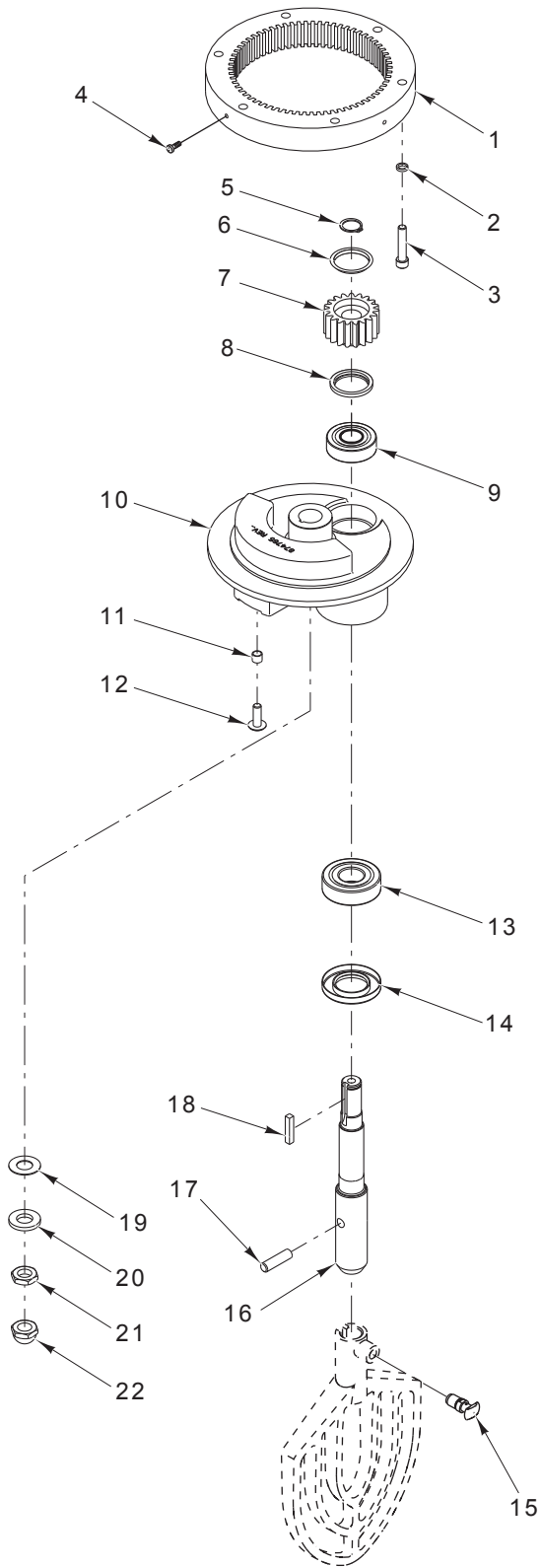

PL-57685

PLANETARY

PLANETARY

ILLUS.	PART NO.	NAME OF PART	AMT.
PL-57685			
1	00-438524-00002	Gear – Internal.....	1
2	WL-003-35	Lockwasher 1/4 Helical.....	6
3	SC-040-09	Cap Screw 1/4-20 x 1 1/4 Hex Socket Hd.....	6
4	SC-066-13	Mach. Screw 8-32 x 1/4 Phil. Truss Hd. (SST).....	3
5	RR-004-18	Ring – Retaining.....	1
6	00-916336	Plug – Friction (1 In. Dia.).....	1
7	00-916335	Pinion – Beater Shaft.....	1
8	00-916512	Seal – Upper Agitator Shaft.....	1
9	BB-018-17	Bearing – Ball Hoover/NSK 6203 DDU.....	1
10	00-916333-00001	Planetary.....	1
11	00-874770	Spacer Bowl Scraper.....	2
12	SC-053-46	Mach. Screw 1/4-20 x 3/4 Slotted Truss Hd. (SST).....	2
13	BB-005-34	Bearing – Ball Hoover/NSK 6204 DDU.....	1
14	00-023482	Seal – Grease 1 In. Dia. Shaft.....	1
15	00-874753	Plunger Assy.	1
16	00-916334	Shaft – Agitator.....	1
17	00-065062-00001	Pin – Dowel.....	1
18	00-012430-00055	Key 3/16 X 3/16 X 1.....	1
19	00-124946	Washer 1/32.....	1
20	WS-030-83	Washer.....	1
21	00-010928-00002	Nut.....	1
22	00-024715-00003	Acorn Nut 1/2-20.....	1
	00-916332	Planetary Subassy. (Incls. Items 5 thru 15, 17, & 20).....	1

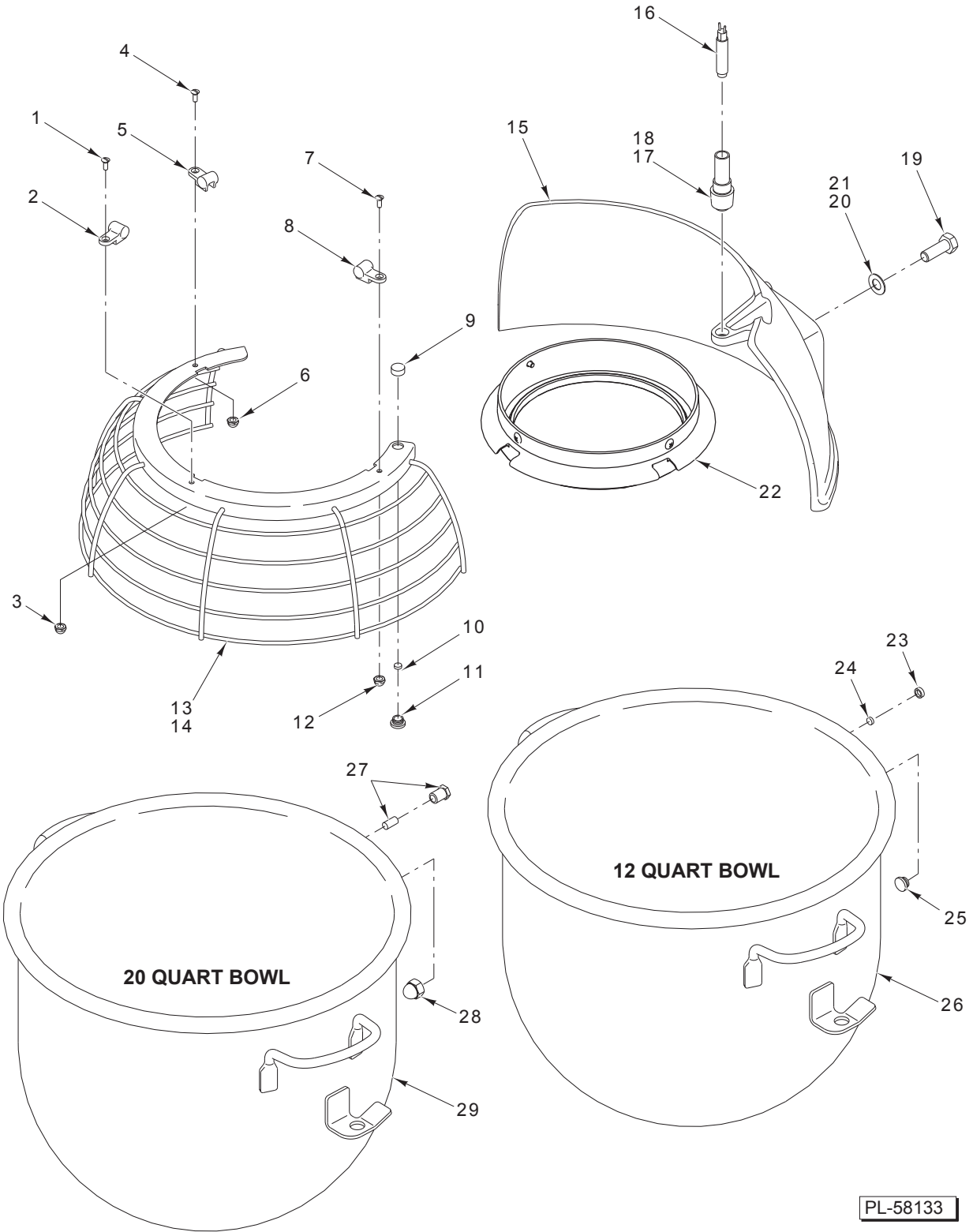

PL-58133

BOWL AND BOWL GUARD

BOWL AND BOWL GUARD

ILLUS.	PART NO.	NAME OF PART	AMT.
PL-58133			
1	SC-129-39	Mach. Screw 6-32 x ⁵ / ₁₆ Slotted Oval Hd.	1
2	00-917349	Carrier – Wire Cage.....	1
3	NS-048-96	Crown Nut 6-32.....	1
4	SC-129-39	Mach. Screw 6-32 x ⁵ / ₁₆ Slotted Oval Hd.	1
5	00-917349-00002	Carrier – Wire Cage (Slotted)	1
6	NS-048-96	Crown Nut 6-32.....	1
7	SC-129-39	Mach. Screw 6-32 x ⁵ / ₁₆ Slotted Oval Hd.	1
8	00-917349	Carrier – Wire Cage.....	1
9	00-917357	Holder – Magnet (Upper).....	1
10	00-874875	Magnet – Disc.....	1
11	00-917358	Holder – Magnet (Lower).....	1
12	NS-048-96	Crown Nut 6-32.....	1
13	00-874822	Wire Cage Assy. (Incls. Items 1 thru 12).....	1
14	00-874822-00002	Wire Cage Assy. (Incls. Items 1 thru 12).....	1
15	00-917234	Guard – Splash.....	1
16	00-087711-00352	Switch – Reed.....	1
17	00-917232	Holder – Switch Reed.....	1
18	00-874839	Pin – Sensor	1
19	SC-118-18	Cap Screw ¹ / ₄ -20 x ⁷ / ₈ Hex Hd.....	2
20	WS-003-19	Washer (HL200).....	2
21	WS-003-46	Washer (HL120).....	4
22	00-917272	Cup – Drip & Flange	1
23	00-917357	Holder – Magnet (Upper).....	1
24	00-874875	Magnet – Disc.....	1
25	00-917358	Holder – Magnet (Lower).....	1
26	00-874864	Bowl Assy. (12 Qt.) (SST) (Packaged) (Incls. Items 23, 24, & 25).....	1
27	00-917527	Housing – Magnet.....	1
28	NS-025-11	Crown Nut ³ / ₈ -24	1
29	00-917720	Bowl Assy. (20 Qt.) (SST) (Packaged) (Incls. Items 27 & 28).....	1

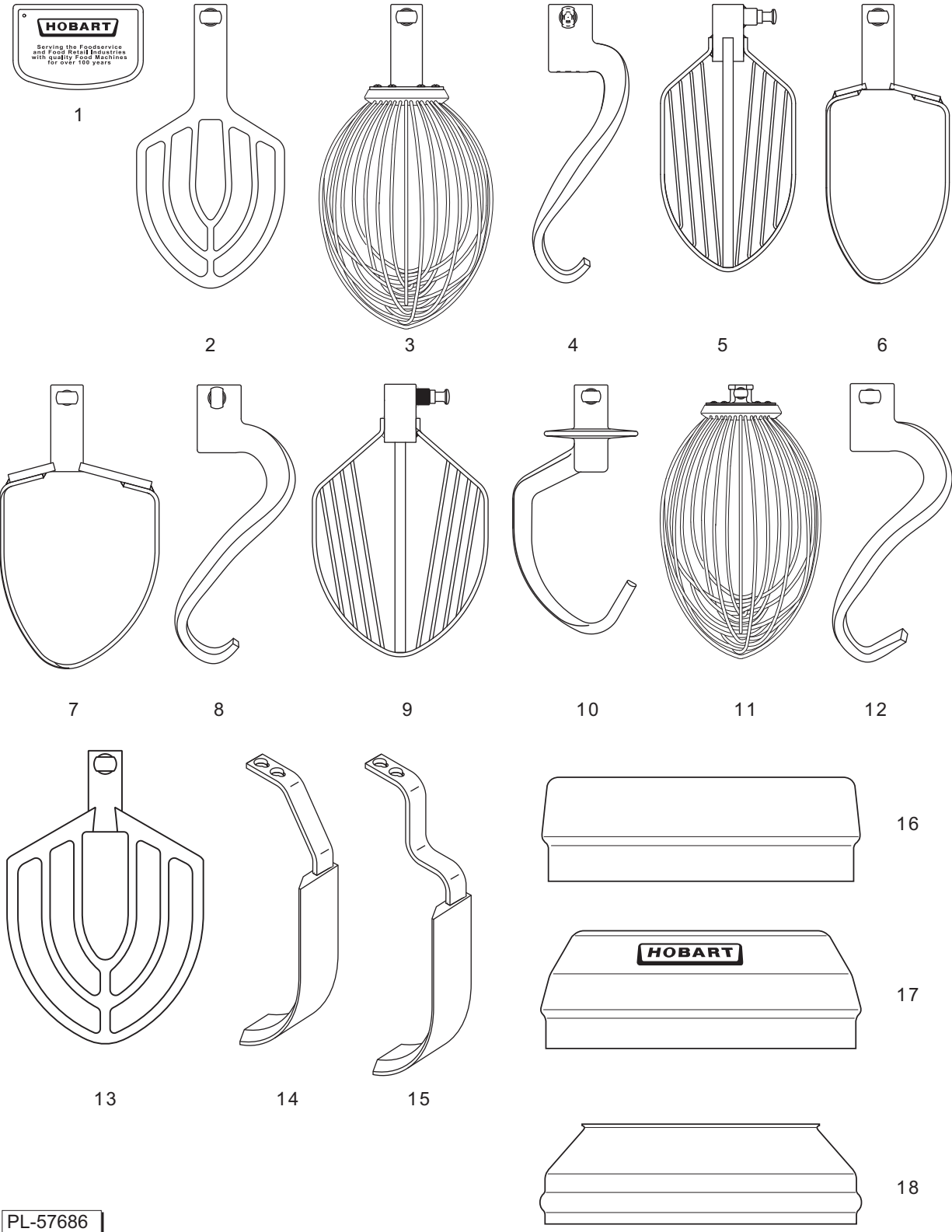

AGITATORS AND ACCESSORIES

AGITATORS AND ACCESSORIES

ILLUS.	PART NO.	NAME OF PART	AMT.
PL-57686			
1	00-913049	Scraper – Bowl	1
2	00-874828	“B” Beater (12 Qt.) (Packaged) (Incls. Item 1)	1
3	00-873360	“D” Wire Whip (12 Qt.) (Packaged) (Incls. Item 1)	1
4	00-873343	“ED” Dough Arm (12 Qt.) (Packaged) (Incls. Item 1)	1
5	00-875893	“C” Whip (12 Qt.) (Packaged) (Incls. Item 1)	1
6	00-873370	Pastry Knife (12 Qt.) (Packaged) (Incls. Item 1)	1
7	00-873294	Pastry Knife (20 Qt.) (Packaged) (Incls. Item 1)	1
8	00-873313	“EDA” Dough Arm (20 Qt.) (Packaged) (Incls. Item 1)	1
9	00-873331	“C” Whip (20 Qt.) (Packaged) (Incls. Item 1)	1
10	00-873335	“E” Dough Arm (20 Qt.) (Packaged) (Incls. Item 1)	1
11	00-874792	“D” Wire Whip (20 Qt.) (Packaged) (Incls. Item 1)	1
12	00-874791	“ED” Dough Arm (20 Qt.) (Packaged) (Incls. Item 1)	1
13	00-874790	“B” Beater (20 Qt.) (Packaged) (Incls. Item 1)	1
14	00-873373	Scraper (12 Qt.) (Packaged)	1
15	00-874836	Scraper (20 Qt.) (Packaged)	1
16	00-438078	Splash Cover (12 Qt.) (Packaged)	1
17	00-438079	Splash Cover (20 Qt.) (Packaged)	1
18	00-875677	Splash Cover (20 Qt.) (SST) (Packaged)	1
	00-874885	Ingredient Chute (Packaged)	1
	00-874899	Tray – Support (Packaged)	1

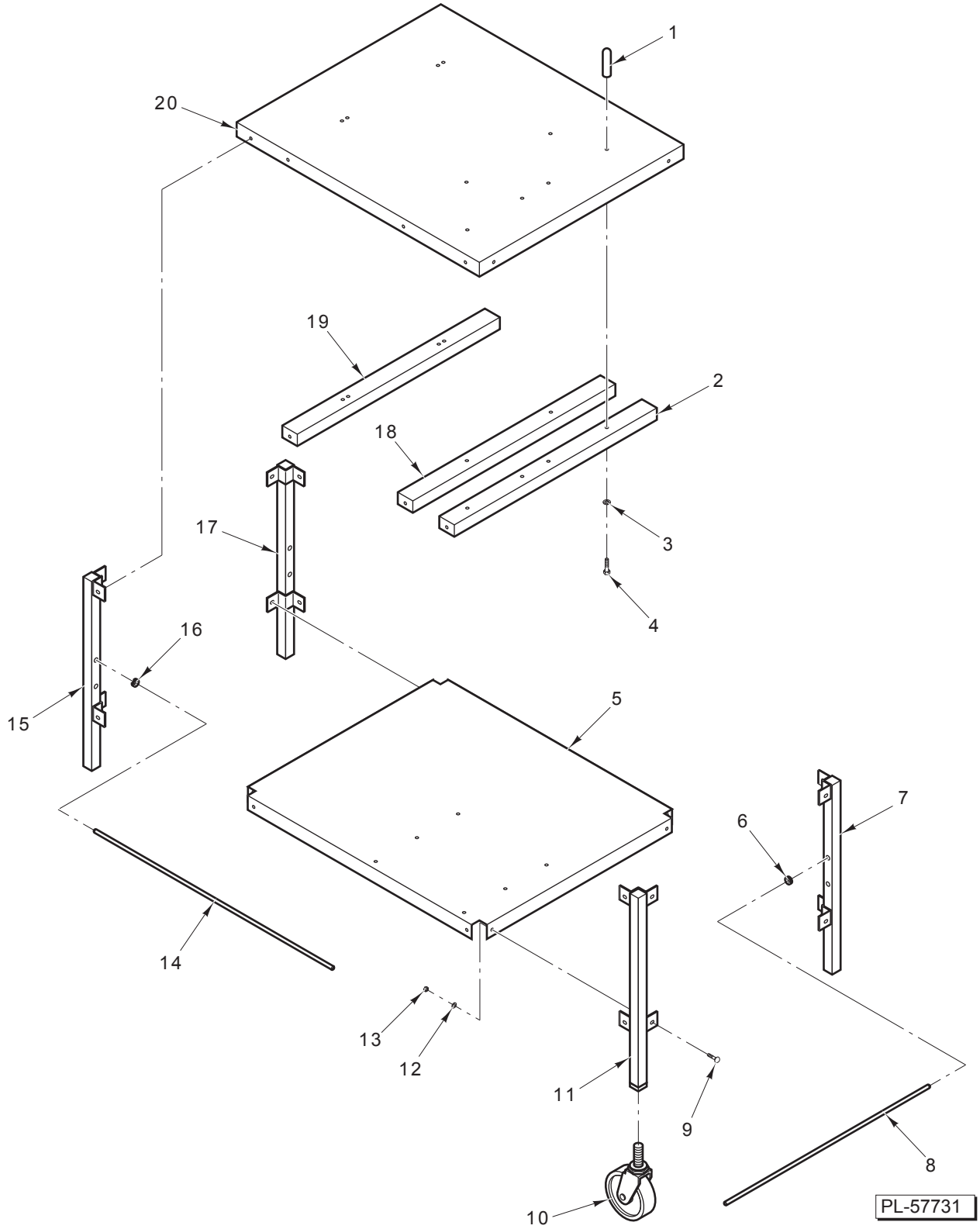

PL-57731

MIXER TABLE (ML-134299)

MIXER TABLE (ML-134299)

ILLUS. PL-57731	PART NO.	NAME OF PART	AMT.
1	00-124075	Post.....	4
2	00-124067	Support – Cross Top	1
3	WL-004-06	Lockwasher ³ / ₈ Helical.....	8
4	SC-037-71	Cap Screw ³ / ₈ -16 x ³ / ₄ Hex Hd.....	8
5	00-123427	Shelf – Table	1
6	00-124076	Grommet.....	4
7	00-124073	Leg – Rear (LH).....	1
8	00-124074-00002	Rod (Short).....	2
9	SC-094-26	Bolt ¹ / ₄ -20 x ¹ / ₂ Sq. Neck Rd. Hd.	22
10	00-205003	Caster – Locking.....	4
11	00-124070	Leg – Rear (RH)	1
12	WS-005-01	Washer.....	22
13	NS-013-02	Nut ¹ / ₄ -20 Hex	22
14	00-124074-00001	Rod (Long).....	4
15	00-124071	Leg – Front (RH).....	1
16	00-124076	Grommet.....	8
17	00-124072	Leg – Front (LH)	1
18	00-875983	Support – Cross Top	1
19	00-124069	Support – Cross Top	1
20	00-875982	Top	1

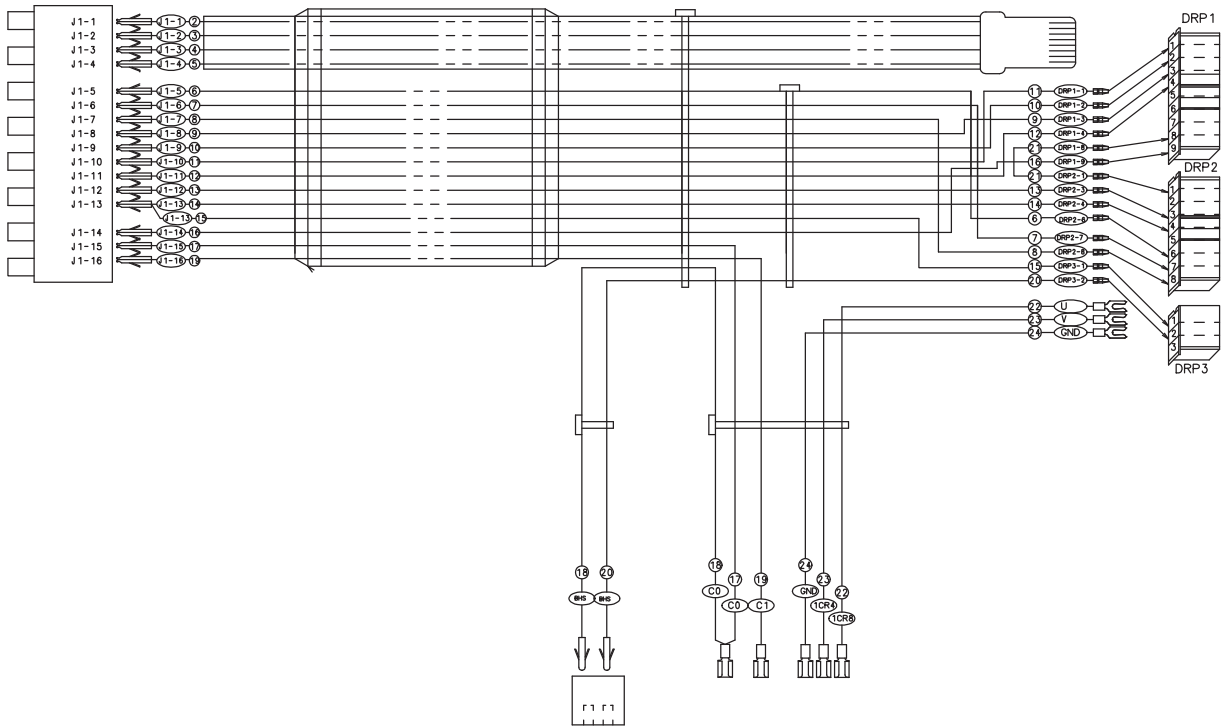

PL-58135

00-917132-00001 Harness - Main Wiring

WIRING HARNESS



CATALOG OF REPLACEMENT PARTS



LEGACY MIXER

HL120	ML-134296
HL200	ML-134289
HL200	ML-134331
HL200C	ML-134312

PREVIOUS MLS COVERED IN THIS MANUAL

HL200	ML-134308
-------	-----------

Table of Contents

5	CONTROL PANEL
6	ELECTRICAL COMPONENTS
7	ATTACHMENT HUB
9	BASE AND PEDESTAL
11	FLOOR BASE AND PEDESTAL (ML-134308 & ML-134331)
12	BOWL SUPPORT
13	TRANSMISSION CASE AND MOTOR
15	TRANSMISSION
17	PLANETARY
19	BOWL AND BOWL GUARD
21	AGITATORS AND ACCESSORIES
23	MIXER TABLE (ML-134299)
24	WIRING HARNESSSES

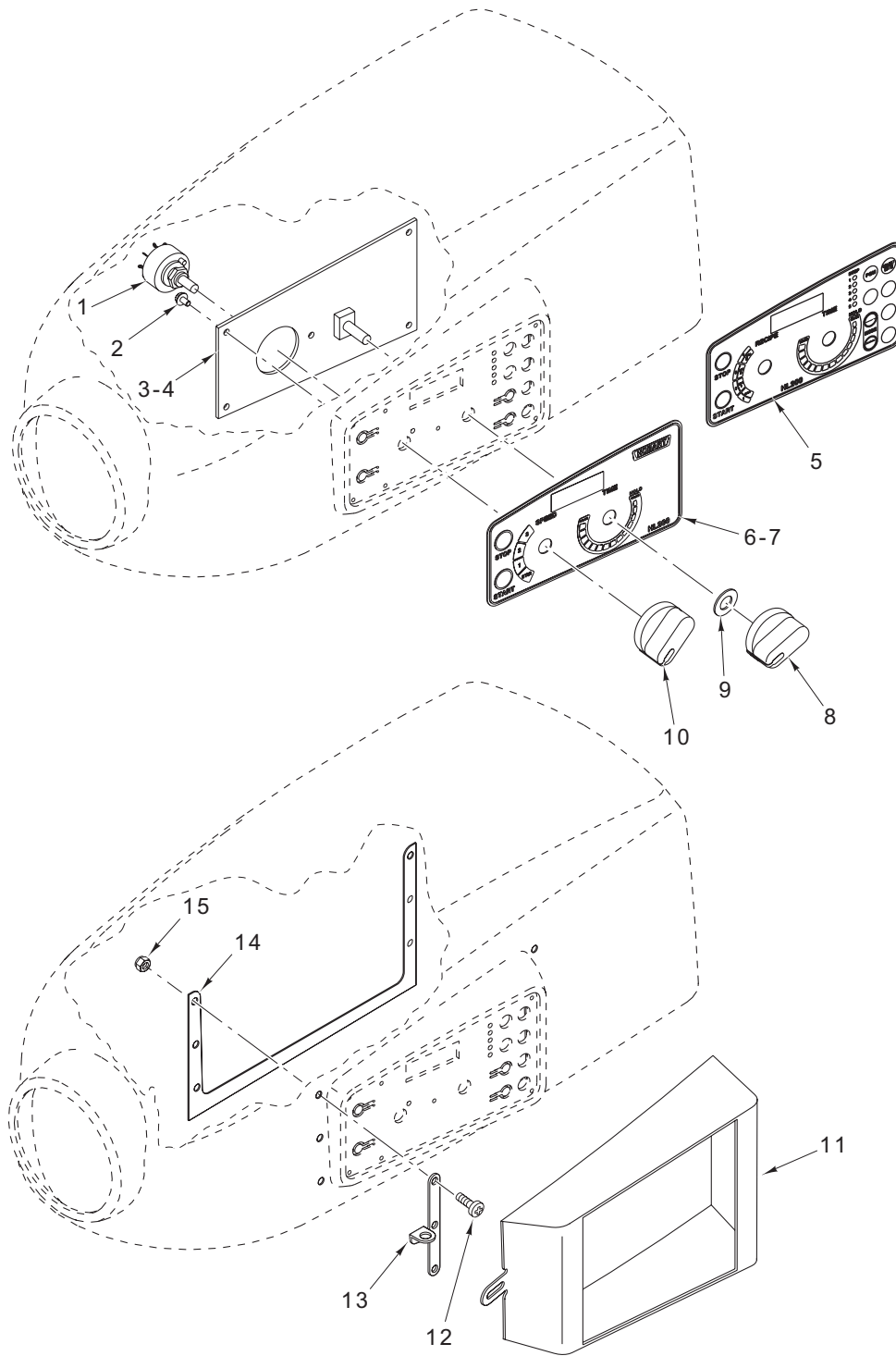

PL-58126

CONTROL PANEL

CONTROL PANEL

ILLUS.	PART NO.	NAME OF PART	AMT.
PL-58126			
1	00-874831	Switch – Speed Selector Assy.	1
2	SD-039-23	Self-Tapping Screw 6-32 x 1/4 Hex Washer Hd., Type RL.....	5
3	00-874883	Board – Timer	1
4	00-874806	Board – Timer (Recipe) (ML-134289).....	1
5	00-874811	Overlay (W/Recipe Timer) (ML-134289).....	1
6	00-874881	Overlay (W/O Recipe Timer) (ML-134289, ML-134308, ML-134331, & ML-134312).....	1
7	00-874868	Overlay (ML-134296).....	1
8	00-874809	Knob	1
9	WS-031-44	Washer.....	1
10	00-874809	Knob	1
11	00-874921	Cover – Weldment (ML-134312)	1
12	SC-128-62	Mach. Screw 10-24 x 1/2 Tx. Button Hd. (ML-134312).....	6
13	00-874923	Latch (ML-134312)	1
14	00-874931	Plate – Backer (ML-134312).....	1
15	NS-038-13	Lock Nut 10-24 Hex (ML-134312)	6

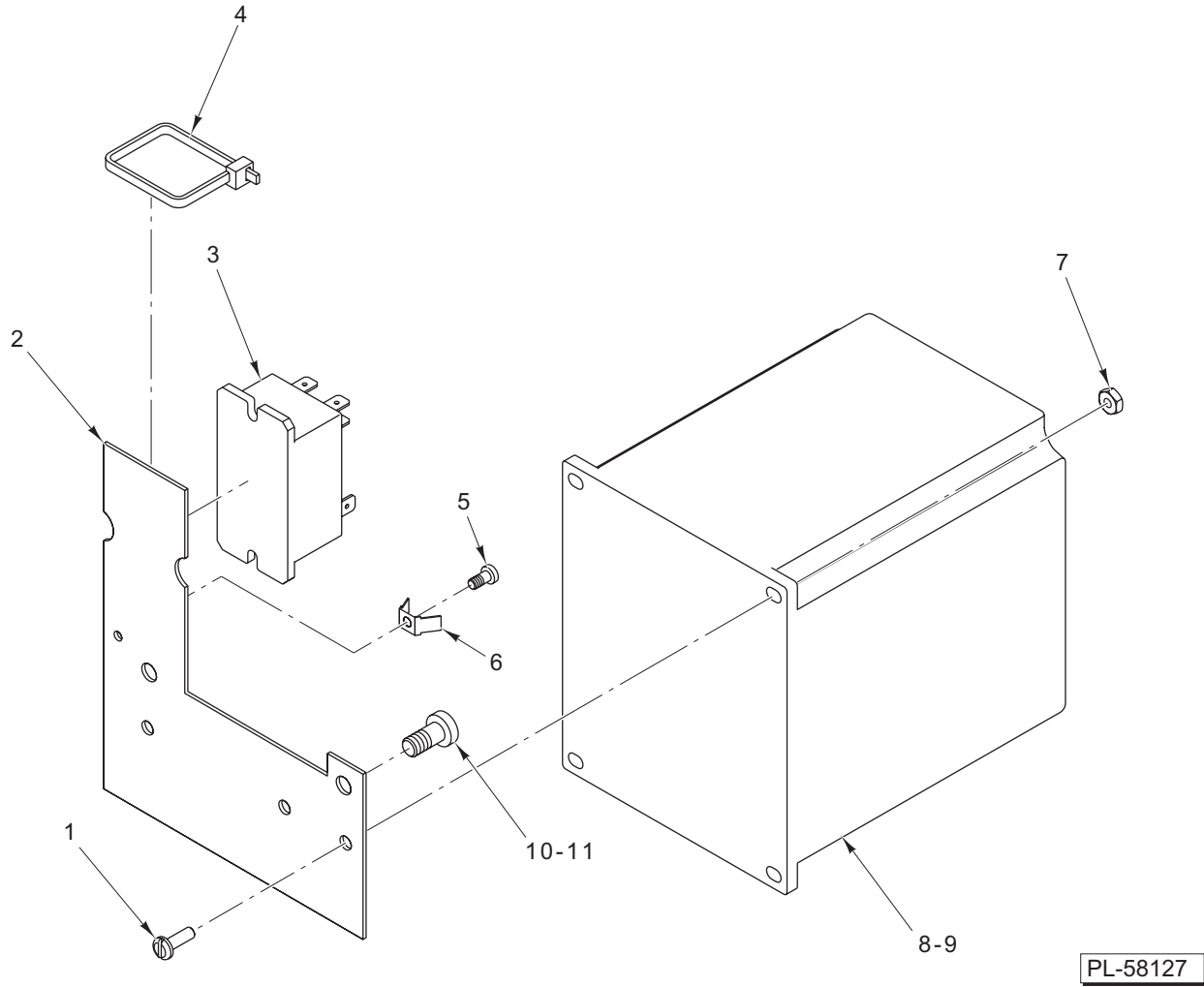

ELECTRICAL COMPONENTS

ILLUS.	PART NO.	NAME OF PART	AMT.
PL-58127			
1	SC-018-38	Mach. Screw 8-32 x 1/2 Slotted Pan Hd.	2
2	00-874763	Bracket – Controller	1
3	00-087714-042-5	Relay (2 Pole, 30 Amp.).....	1
4	00-539847	Tie – Cable 8 In.....	1
5	SD-015-37	Self-Tapping Screw 6-32 x 1/4 Phil. Pan Hd., Type TT.....	1
6	00-065890-00090	Terminal (2-Tab).....	1
7	NS-009-12	Mach. Nut 8-32 Hex.....	2
8	00-874775-00002	Motor Drive (120 V.).....	1
9	00-874776-00002	Motor Drive (240 V.) (ML-134289, ML-134296, ML-134331, & ML-134308)	1
10	SC-114-80	Mach. Screw 1/4-20 x 3/8 Slotted Pan Hd.	2
11	SC-089-01	Cap Screw 1/4-20 x 1/2 Hex Socket Hd. (ML-134308 & ML-134331)	2

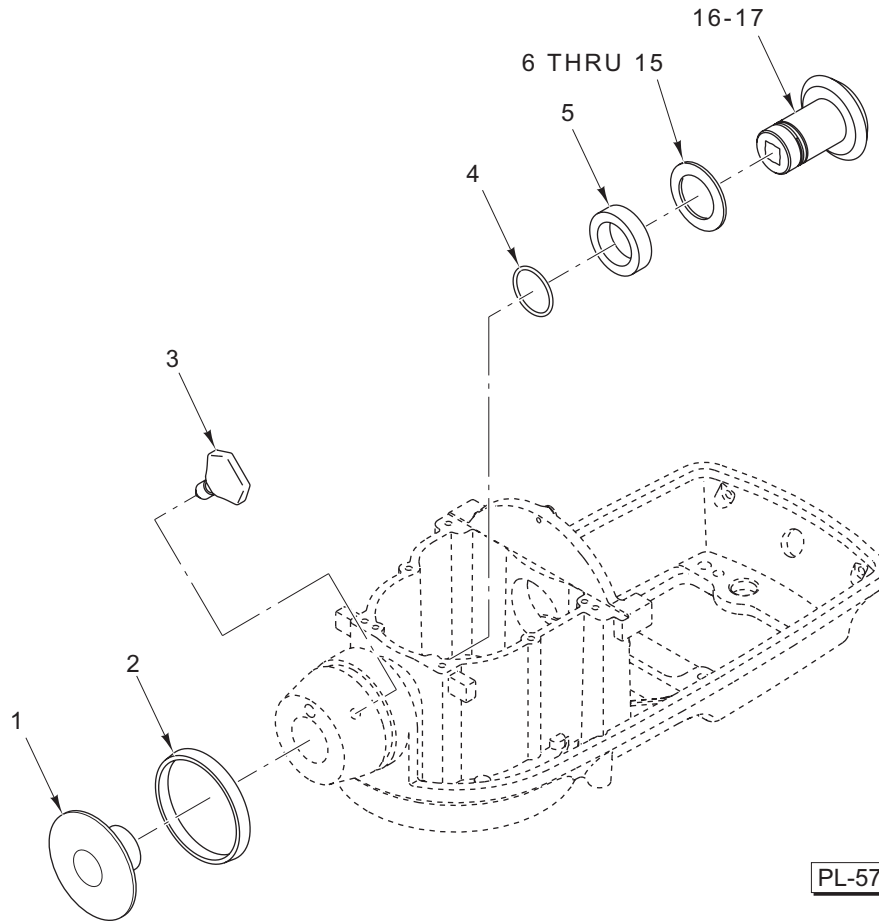

ATTACHMENT HUB

ILLUS. PL-57679	PART NO.	NAME OF PART	AMT.
1	00-114824-00001	Plug – Attachment.....	1
2	00-874925-00004	Seal – Neopreme.....	1
3	00-108197-00001	Screw – Thumb 1.125.....	1
4	OR-001-03	O-Ring – Quad.....	1
5	00-874837	Spacer.....	1
6	00-012746-00005	Washer – Thrust (0.080).....	AR
7	00-012746-00006	Washer – Thrust (0.106).....	AR
8	00-012746-00007	Washer – Thrust (0.092).....	AR
9	00-012746-00008	Washer – Thrust (0.086).....	AR
10	00-012746-00009	Washer – Thrust (0.098).....	AR
11	00-012746-00010	Washer – Thrust (0.112).....	AR
12	00-012746-00012	Washer – Thrust (0.119).....	AR
13	00-012746-00013	Washer – Thrust (0.121).....	AR
14	00-012746-00016	Washer – Thrust (0.129).....	AR
15	00-012746-00019	Washer – Thrust (0.115).....	AR
16	00-435065-00002	Bevel Gear Seal Assy. (Incls. Item 17).....	1
17	PL-003-17	Plug – Expansion.....	1

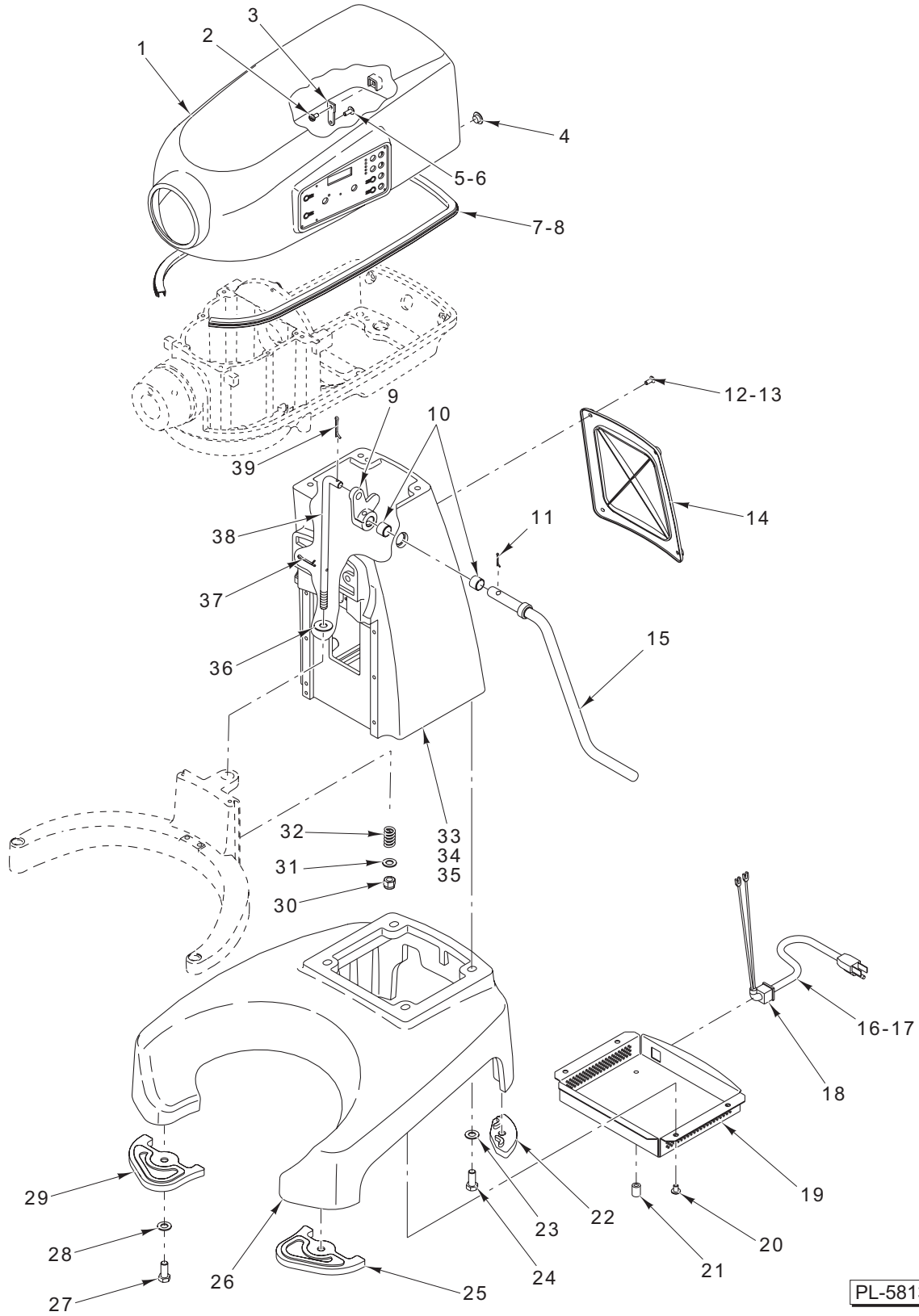

PL-58131

BASE AND PEDESTAL

BASE AND PEDESTAL

ILLUS. PL-58131	PART NO.	NAME OF PART	AMT.
1	00-916262	Cover – Top	1
2	SD-024-01	Self-Tapping Screw 10-24 x 3/8 Slotted Pan Hd., Type TT	2
3	00-874829	Tab – Cover Mounting.....	2
4	00-874857	Plug – Hole	1
5	SC-066-20	Mach. Screw 10-32 x 1/2 Phil. Truss Hd. (SST).....	2
6	SC-128-81	Mach. Screw 10-32 x 1/2 Tx. Button Hd. (ML-134312)	2
7	00-874925-00001	Seal – Neopreme.....	1
8	00-874925-00002	Seal – Neopreme.....	1
9	00-874756	Arm – Bowl Lift.....	1
10	00-479510	Bushing – Bowl Lift	2
11	PS-004-15	Pin – Spirol (1/4).....	1
12	SC-015-34	Mach. Screw 10-24 x 1/2 Slotted Oval Hd.	4
13	SC-128-75	Mach. Screw 10-24 x 5/8 Flat. Hd. (SST) (ML-134312)	4
14	00-874749	Cover – Pedestal (Back).....	1
15	00-874745-00002	Handle & Bushing – Bowl Lift	1
16	00-874833-00001	Cord & Plug Assy. (120 V.).....	1
17	00-874833-00002	Cord & Plug Assy. (220 V.) (ML-134289 & ML-134296)	1
18	FE-026-34	Relief – Strain (Electrical) (ML-134289, ML-134296, & ML-134312).....	1
19	00-874760	Cover – Controller (ML-134289, ML-134296, & ML-134312)	1
20	SC-114-80	Mach. Screw 1/4-20 x 3/8 Phil. Pan Hd. (ML-134289, ML-134296, & ML-134312)	4
21	FE-026-43	Bushing – Electric Snap (ML-134296 & ML-134289)	1
22	00-874879	Pad – Rear (ML-134289, ML-134296, & ML-134312)	2
23	WS-018-24	Washer (ML-134289, ML-134296, & ML-134312)	4
24	SC-118-11	Cap Screw 3/8-16 x 7/8 Hex Hd. (ML-134289, ML-134296, & ML-134312)	4
25	00-874896	Pad – Front (RH) (ML-134289, ML-134296, & ML-134312)	1
26	00-874720-00002	Base (ML-134289, ML-134296, & ML-134312)	1
27	SC-118-12	Cap Screw 3/8-16 x 3/4 Hex Hd. (ML-134289, ML-134296, & ML-134312)	4
28	WS-018-34	Washer (ML-134289, ML-134296, & ML-134312)	4
29	00-874878	Pad – Front (LH) (ML-134289, ML-134296, & ML-134312).....	4
30	NS-036-15	Stop Nut 3/8-24 Special	1
31	WS-006-26	Washer.....	1
32	00-012782	Spring	1
33	00-874723-00002	Pedestal.....	1
34	00-874925-00003	Seal – Neopreme.....	1
35	SC-100-08	Mach. Screw 1/4-20 x 3/8 Hex Washer Hd.	2
36	WS-006-26	Washer.....	1
37	PC-003-55	Cotter Pin 1/8	1
38	00-874748	Rod – Bowl Lift.....	1
39	PC-003-55	Cotter Pin 1/8	1

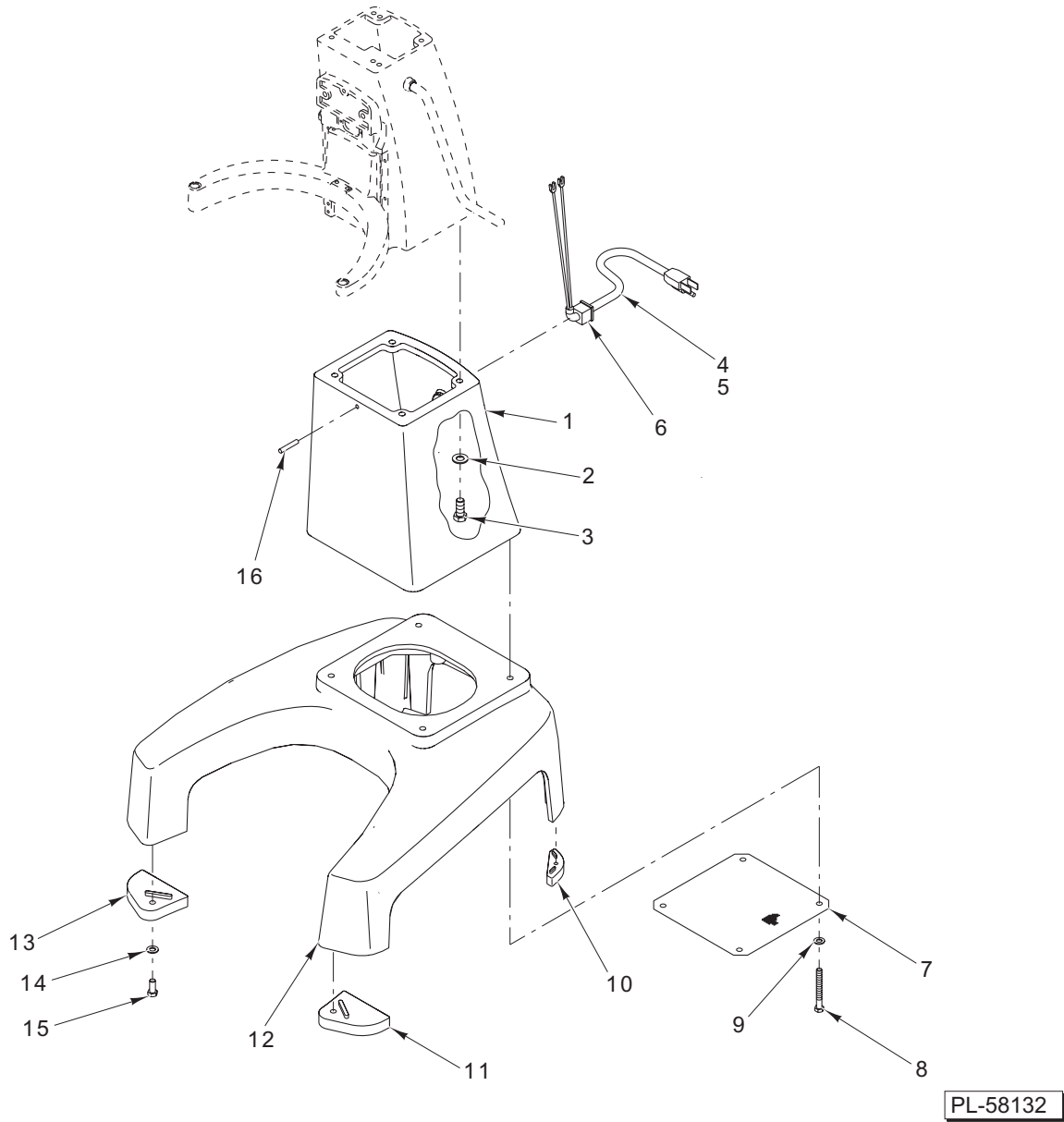

FLOOR BASE AND PEDESTAL (ML-134308& ML-134331)

FLOOR BASE AND PEDESTAL (ML-134308 & ML-134331)

ILLUS.	PART NO.	NAME OF PART	AMT.
PL-58132			
1	00-916222-00002	Block – Riser.....	1
2	WS-018-24	Washer.....	8
3	SC-118-10	Cap Screw 3/8-16 x 1 Hex Hd.....	4
4	00-874833-00001	Cord & Plug Assy. (120 V.).....	1
5	00-874833-00002	Cord & Plug Assy. (220 V.).....	1
6	FE-022-84	Relief – Strain (Electrical).....	1
7	00-916330	Screen – Air Floor.....	1
8	SC-124-91	Cap Screw 3/8-16 x 2 1/2 Hex Hd.....	4
9	WS-018-24	Washer.....	8
10	00-916309	Pad – Rear.....	2
11	00-916308	Pad – Front (RH).....	1
12	00-916213-00002	Base.....	1
13	00-916307	Pad – Front (LH).....	1
14	WS-018-34	Washer.....	4
15	SC-118-12	Cap Screw 3/8-16 x 3/4 Hex Hd.....	4
16	PG-005-25	Pin – Grooved.....	1

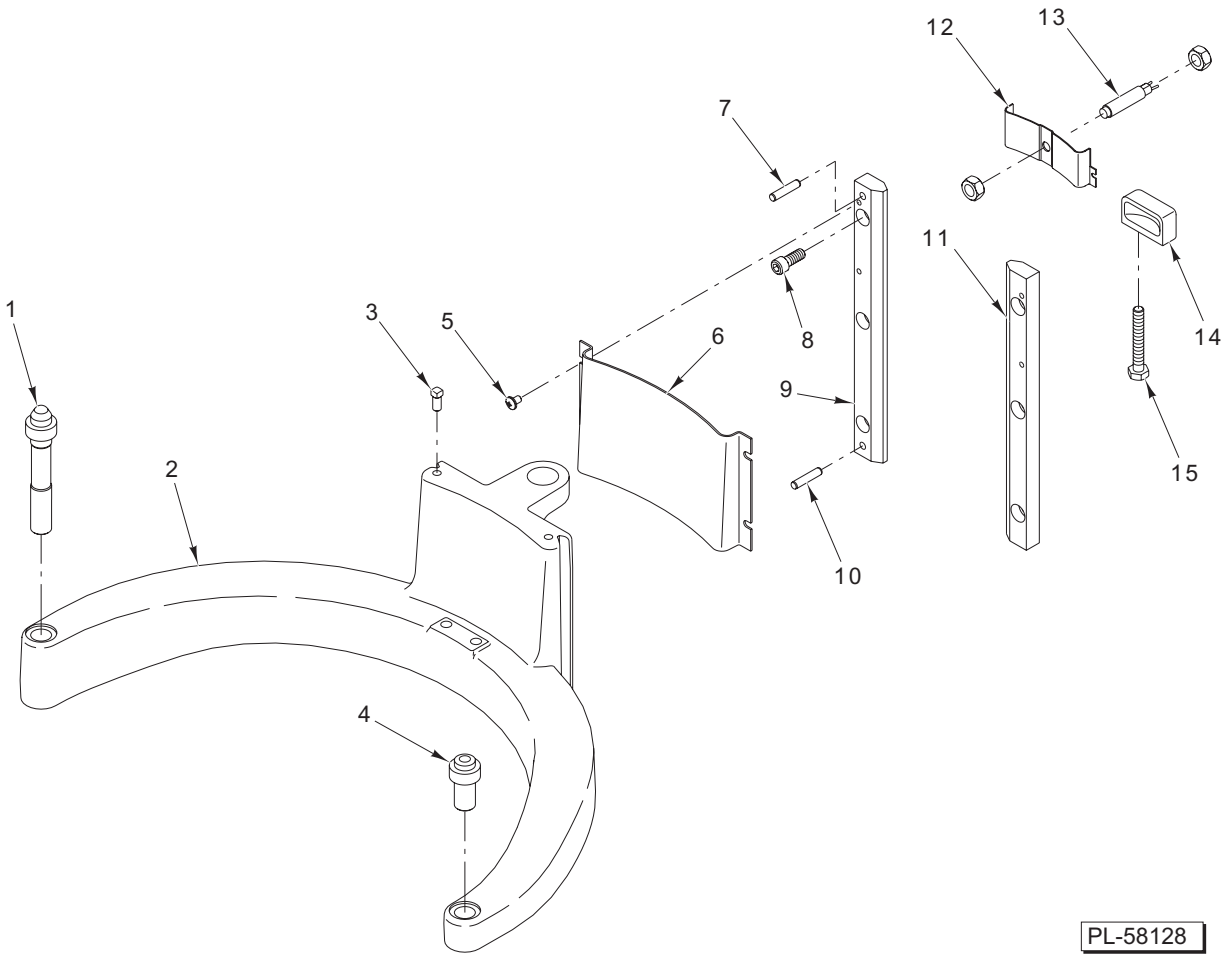

PL-58128

BOWL SUPPORT

ILLUS.	PART NO.	NAME OF PART	AMT.
PL-58128			
1	00-874726	Pin – Bowl (LH).....	1
2	00-874841-00002	Support – Bowl	1
3	SC-129-22	Set Screw 1/4-20 x 1/4 Sq. Hd. Cup Pt.....	2
4	00-874727	Pin – Bowl (RH)	1
5	SC-122-59	Mach. Screw 8-32 x 1/4 Phil. Pan Hd. (SST)	4
6	00-874742	Apron	1
7	00-011800-00187	Dowel.....	2
8	SC-040-09	Cap Screw 1/4-20 x 1 1/4 Hex Socket Hd.....	6
9	00-874738-00001	Slideway – Bowl Lift (LH).....	1
10	00-011800-00187	Dowel.....	2
11	00-874738-00002	Slideway – Bowl Lift (RH)	1
12	00-874884	Cover – Bowl Interlock.....	1
13	00-087711-00352	Switch – Reed.....	1
14	00-874842	Hold Down – Bowl (Rear)	1
15	SC-062-69	Cap Screw 1/4-20 x 1 3/4 Hex Hd.....	2
	PB-004-97	Cap	4

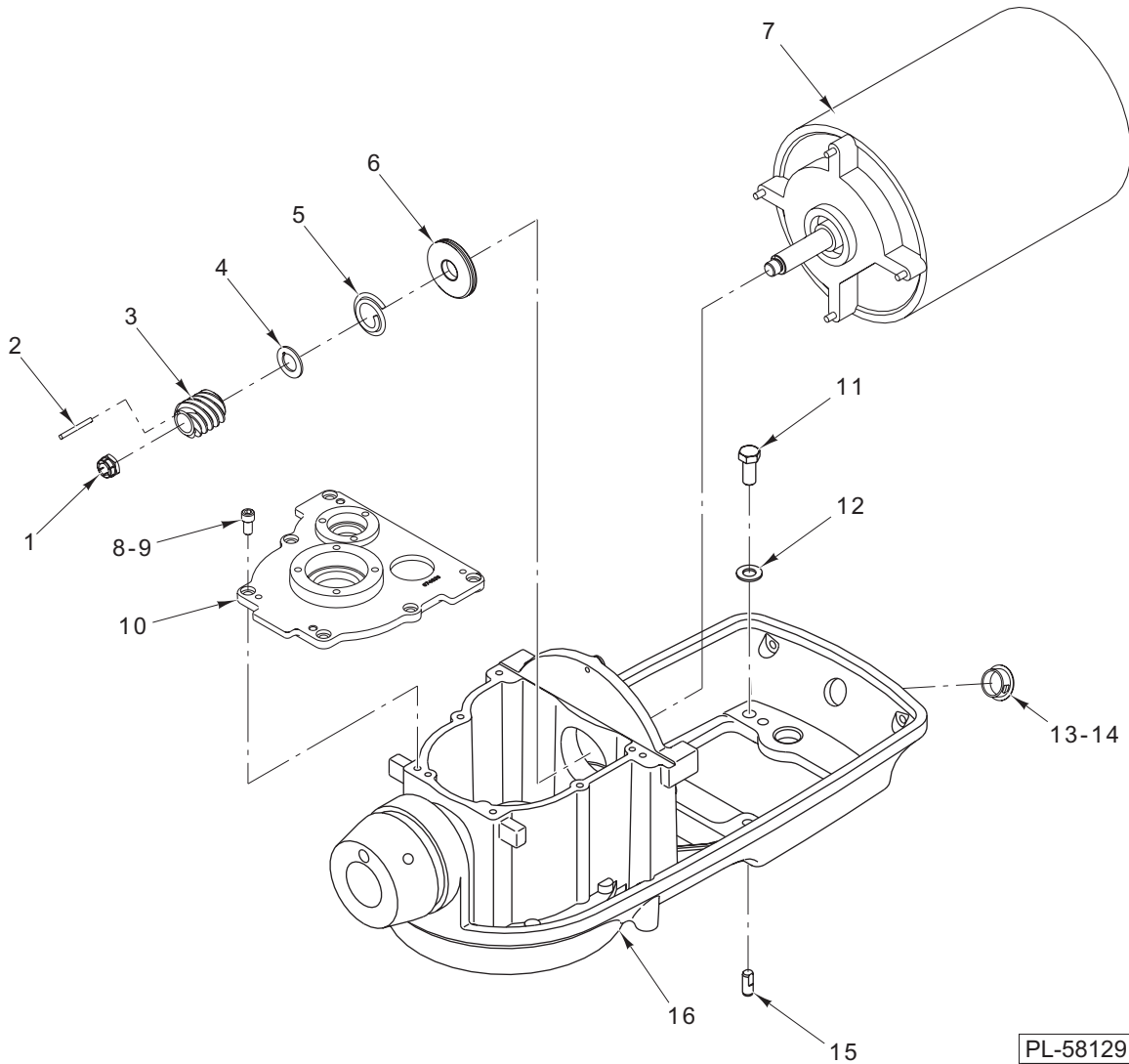

TRANSMISSION CASE AND MOTOR

ILLUS.	PART NO.	NAME OF PART	AMT.
	PL-58129		
1	NS-032-23	Lock Nut $\frac{7}{16}$ -20 Special	1
2	00-012430-00004	Key $\frac{1}{8}$ x $\frac{1}{8}$ x $1\frac{1}{4}$	1
3	00-291221	Worm – Gear 60 Cycle	1
4	00-012754	Washer.....	1
5	00-012757	Absorber – Shock Spring.....	1
6	00-874820	Deflector – Grease (LH).....	1
7	00-874634	Motor.....	1
8	SC-089-01	Cap Screw $\frac{1}{4}$ -20 x $\frac{1}{2}$ Hex Socket Hd. (HL200).....	6
9	SC-089-02	Cap Screw $\frac{1}{4}$ -20 x $\frac{3}{4}$ Hex Socket Hd. (HL120).....	6
10	00-874755	Cover – Transmission	1
11	SC-118-11	Cap Screw $\frac{3}{8}$ -16 x $\frac{7}{8}$ Hex Hd.....	4
12	WS-018-24	Washer.....	4
13	00-874857	Plug.....	1
14	00-874876	Plug – Cupped Expansion	1
15	00-270776	Dowel.....	2
16	00-874783	Transmission Case – Lower	1

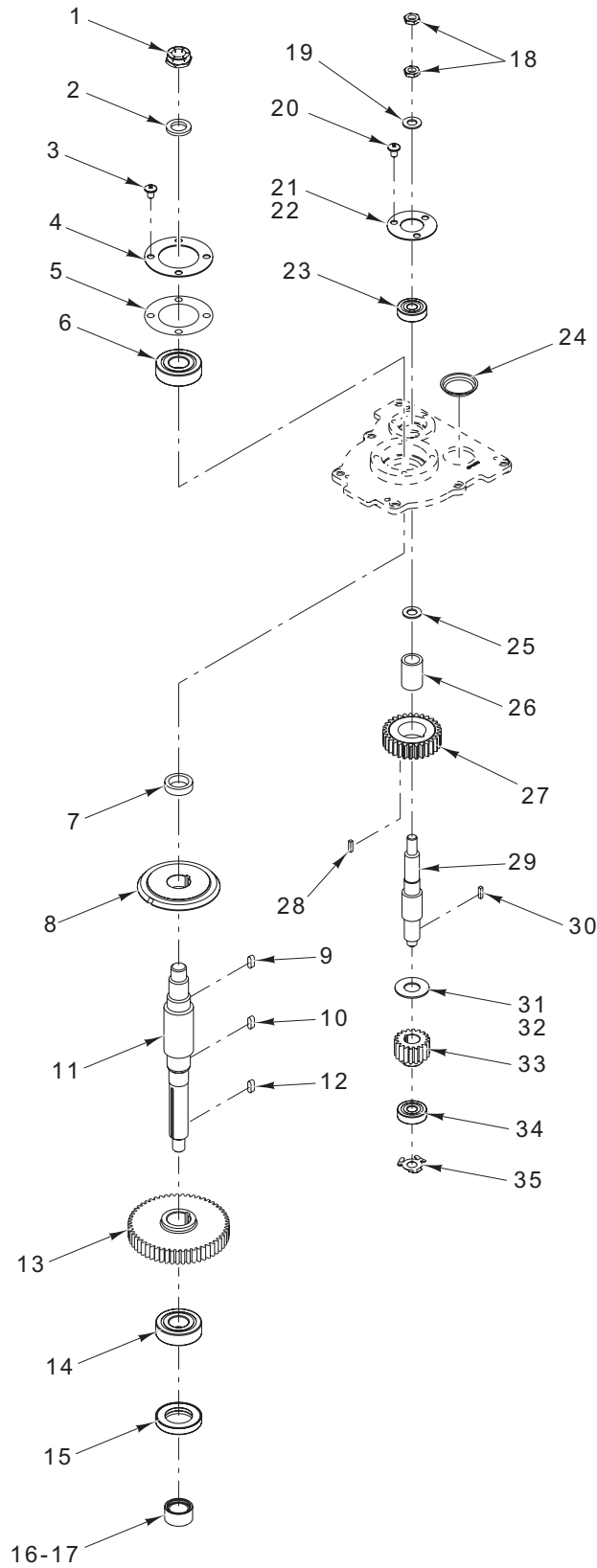

TRANSMISSION

PL-58130

TRANSMISSION

ILLUS.	PART NO.	NAME OF PART	AMT.
	PL-58130		
1	NS-032-37	Lock Nut ⁵ / ₈ -18 Special	1
2	WS-031-41	Washer.....	1
3	SC-114-80	Mach. Screw ¹ / ₄ -20 x ³ / ₈ Phil. Pan Hd.	4
4	00-874787	Retainer – Planetary Bearing.....	1
5	00-874795	Gasket – Bearing	1
6	BB-005-34	Bearing – Ball	1
7	00-874793	Spacer – Planetary	1
8	00-124733-00002	Gear – Bevel (46T, 14P)	1
9	00-874873-00001	Key.....	1
10	00-874873-00002	Key.....	1
11	00-874635	Shaft – Planetary	1
12	00-012430-00017	Key ¹ / ₈ x ¹ / ₈ x 2 ⁷ / ₁₆	1
13	00-874778	Gear (55T, 14P)	1
14	BB-020-06	Bearing – Ball Fafnir 204K.....	1
15	00-114695	Seal – Oil	1
16	00-437342	Spacer – Bearing	1
17	00-067500-00078	O-Ring	1
18	00-012710	Nut – Retaining	2
19	WS-006-36	Washer (ML-134289, ML-134308, ML-134331, & ML-134312).....	1
20	SC-114-80	Mach. Screw ¹ / ₄ -20 x ³ / ₈ Phil. Pan Hd.	3
21	00-874788	Retainer – Bearing.....	1
22	BB-005-02	Bearing – Ball	1
23	BB-005-01	Bearing – Ball Fafnir 200K.....	1
24	00-064871	Plug – Friction.....	1
25	WS-006-26	Washer.....	1
26	00-874780	Spacer – Gear	1
27	00-874934	Gear – Worm (29T).....	1
28	00-012430-00024	Key ¹ / ₈ x ¹ / ₈ x 1 ¹ / ₂	1
29	00-874779	Shaft – Worm Wheel.....	1
30	00-012430-00024	Key ¹ / ₈ x ¹ / ₈ x 1 ¹ / ₂	1
31	WS-010-36	Washer (ML-134296 & ML-134289)	1
32	WS-006-26	Washer (ML-134308, ML-134331, & ML-134312)	1
33	00-874777	Gear (18T, 14P)	1
34	BB-005-01	Bearing – Ball Fafnir 200K.....	1
35	SL-002-08	Spring – Loading.....	1

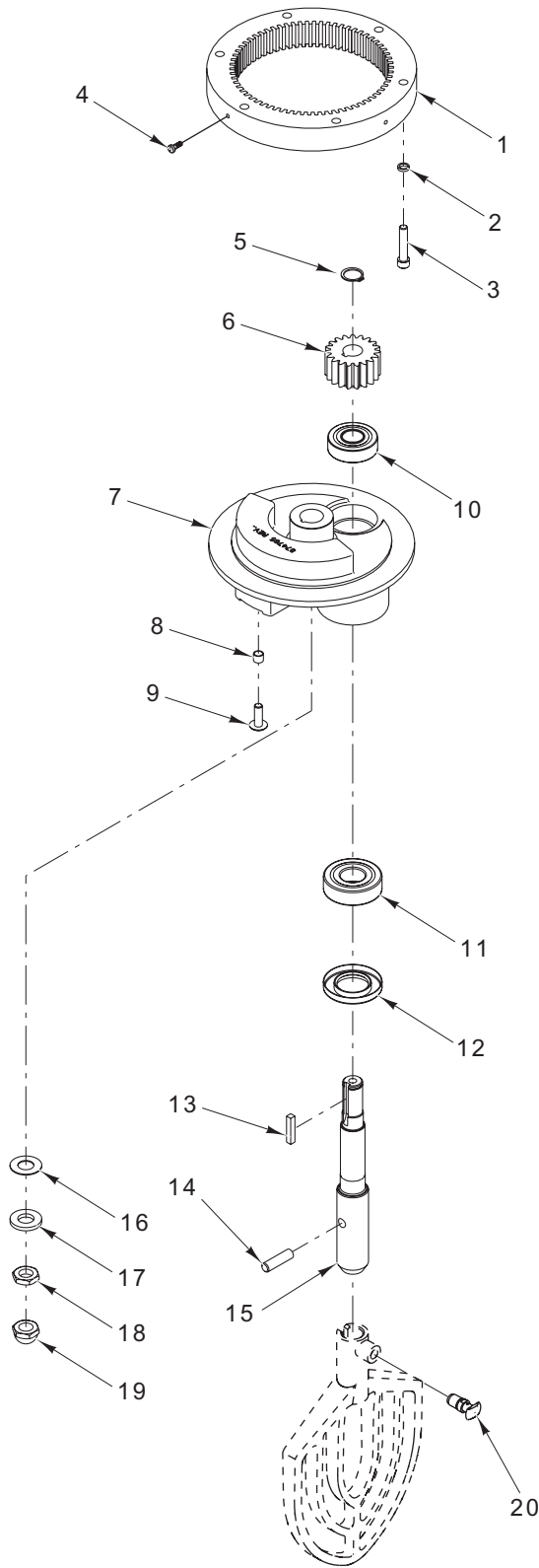

PL-57685

PLANETARY

PLANETARY

ILLUS.	PART NO.	NAME OF PART	AMT.
PL-57685			
1	00-438524-00002	Gear – Internal.....	1
2	WL-003-35	Lockwasher 1/4 Helical	6
3	SC-040-09	Cap Screw 1/4-20 x 1 1/4 Hex Socket Hd.....	6
4	SC-066-13	Mach. Screw 8-32 x 1/4 Phil. Truss Hd. (SST).....	3
5	RR-004-18	Ring – Retaining	1
6	00-015217	Pinion – Beater (19T).....	1
7	00-874766-00002	Planetary.....	1
8	00-874770	Spacer Bowl Scraper.....	2
9	SC-053-46	Mach. Screw 1/4-20 x 3/4 Slotted Truss Hd. (SST)	2
10	BB-018-17	Bearing – Ball Hoover/NSK 6203 DDU.....	1
11	BB-005-34	Bearing – Ball Hoover/NSK 6204 DDU.....	1
12	00-023482	Seal – Grease 1 In. Dia. Shaft.....	1
13	00-012430-00055	Key 3/16 X 3/16 X 1.....	1
14	00-065062-00001	Pin – Dowel.....	1
15	00-874739	Shaft – Agitator	1
16	00-124946	Washer 1/32	1
17	WS-030-83	Washer.....	1
18	00-010928-00002	Nut	1
19	00-024715-00003	Acorn Nut 1/2-20	1
20	00-874753	Plunger Assy.	1
	00-874767	Planetary Subassy. (Incls. Items 5 thru 15)	1

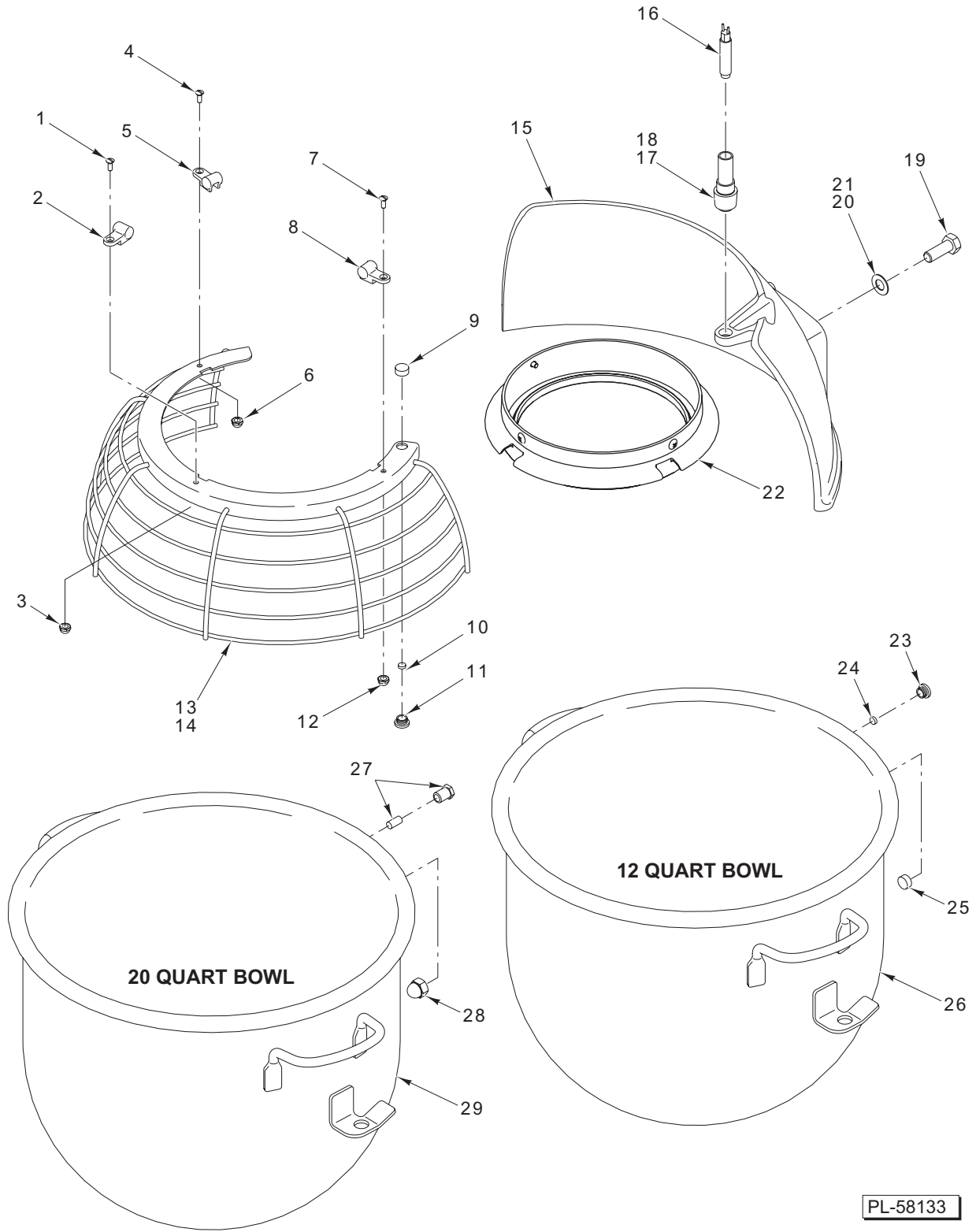

BOWL AND BOWL GUARD

BOWL AND BOWL GUARD

ILLUS.	PART NO.	NAME OF PART	AMT.
PL-58133			
1	SC-129-39	Mach. Screw 6-32 x ⁵ / ₁₆ Slotted Oval Hd.	1
2	00-874816	Carrier – Wire Cage.....	1
3	NS-048-96	Crown Nut 6-32.....	1
4	SC-129-39	Mach. Screw 6-32 x ⁵ / ₁₆ Slotted Oval Hd.	1
5	00-874816-00002	Carrier – Wire Cage (Slotted)	1
6	NS-048-96	Crown Nut 6-32.....	1
7	SC-129-39	Mach. Screw 6-32 x ⁵ / ₁₆ Slotted Oval Hd.	1
8	00-874816	Carrier – Wire Cage.....	1
9	00-874887	Holder – Magnet (Upper).....	1
10	00-874875	Magnet – Disc.....	1
11	00-874886	Holder – Magnet (Lower).....	1
12	NS-048-96	Crown Nut 6-32.....	1
13	00-874822	Wire Cage Assy. (Incls. Items 1 thru 12).....	1
14	00-874822-00002	Wire Cage Assy. (Incls. Items 1 thru 12) (ML-134312).....	1
15	00-874815	Guard – Splash.....	1
16	00-087711-00352	Switch – Reed.....	1
17	00-874786	Holder – Switch Reed.....	1
18	00-874839	Pin – Sensor	1
19	SC-118-18	Cap Screw ¹ / ₄ -20 x ⁷ / ₈ Hex Hd.....	2
20	WS-003-19	Washer (HL200).....	2
21	WS-003-46	Washer (HL120).....	4
22	00-916408	Cup – Drip & Flange	1
23	00-874887	Holder – Magnet (Upper).....	1
24	00-874875	Magnet – Disc.....	1
25	00-874886	Holder – Magnet (Lower).....	1
26	00-874864	Bowl Assy. (12 Qt.) (SST) (Packaged) (Incls. Items 23, 24, & 25).....	1
27	00-874847	Housing & Magnet	1
28	NS-025-11	Crown Nut ³ / ₈ -24	1
29	00-874834	Bowl Assy. (20 Qt.) (SST) (Packaged) (Incls. Items 27 & 28).....	1

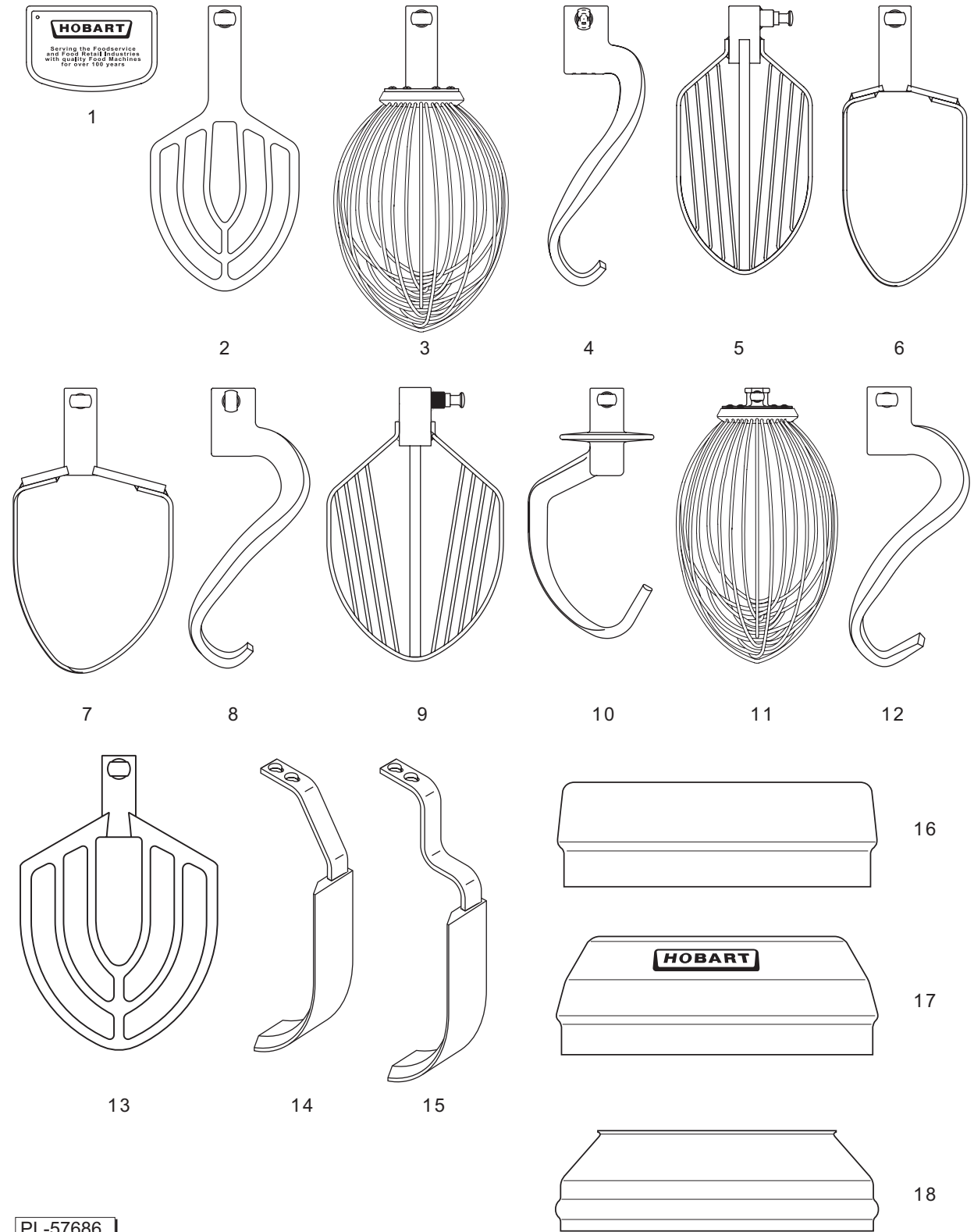

PL-57686

AGITATORS AND ACCESSORIES

AGITATORS AND ACCESSORIES

ILLUS.	PART NO.	NAME OF PART	AMT.
PL-57686			
1	00-118801	Scraper – Bowl (Handheld).....	1
2	00-874828	“B” Beater (12 Qt.) (Packaged) (Incls. Item 1).....	1
3	00-873360	“D” Wire Whip (12 Qt.) (Packaged) (Incls. Item 1).....	1
4	00-873343	“ED” Dough Arm (12 Qt.) (Packaged) (Incls. Item 1).....	1
5	00-875893	“C” Whip (12 Qt.) (Packaged) (Incls. Item 1).....	1
6	00-873370	Pastry Knife (12 Qt.) (Packaged) (Incls. Item 1).....	1
7	00-873294	Pastry Knife (20 Qt.) (Packaged) (Incls. Item 1).....	1
8	00-873313	“EDA” Dough Arm (20 Qt.) (Packaged) (Incls. Item 1).....	1
9	00-873331	“C” Whip (20 Qt.) (Packaged) (Incls. Item 1).....	1
10	00-873335	“E” Dough Arm (20 Qt.) (Packaged) (Incls. Item 1).....	1
11	00-874792	“D” Wire Whip (20 Qt.) (Packaged) (Incls. Item 1).....	1
12	00-874791	“ED” Dough Arm (20 Qt.) (Packaged) (Incls. Item 1).....	1
13	00-874790	“B” Beater (20 Qt.) (Packaged) (Incls. Item 1).....	1
14	00-873373	Scraper (12 Qt.) (Packaged).....	1
15	00-874836	Scraper (20 Qt.) (Packaged).....	1
16	00-438078	Splash Cover (12 Qt.) (Packaged).....	1
17	00-438079	Splash Cover (20 Qt.) (Packaged).....	1
18	00-875677	Splash Cover (20 Qt.) (SST) (Packaged).....	1
	00-874885	Ingredient Chute (Packaged).....	1
	00-874899	Tray – Support (Packaged).....	1

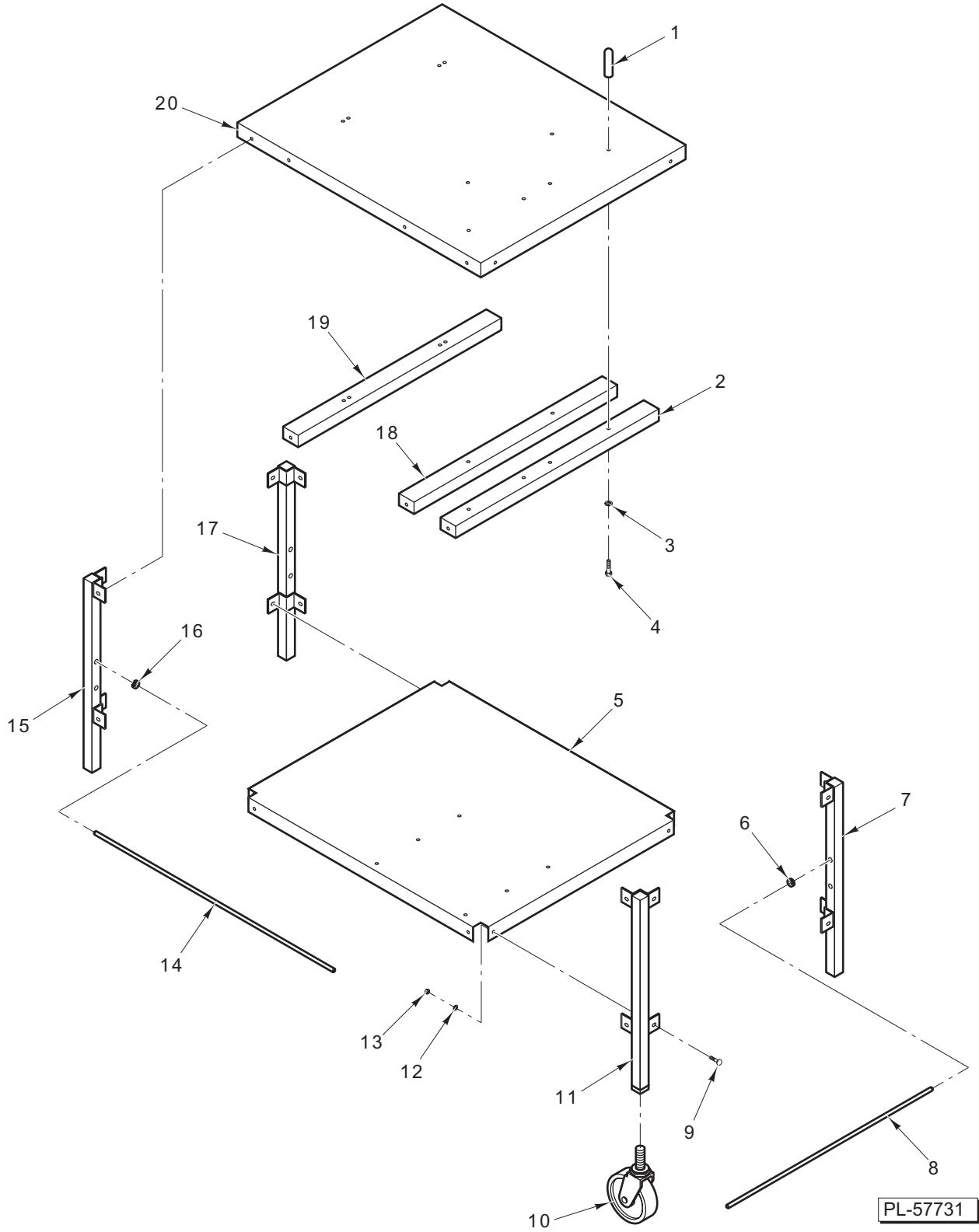

MIXER TABLE (ML-134299)

MIXER TABLE (ML-134299)

ILLUS. PL-57731	PART NO.	NAME OF PART	AMT.
1	00-124075	Post.....	4
2	00-124067	Support – Cross Top	1
3	WL-004-06	Lockwasher ³ / ₈ Helical	8
4	SC-037-71	Cap Screw ³ / ₈ -16 x ³ / ₄ Hex Hd.....	8
5	00-123427	Shelf – Table	1
6	00-124076	Grommet.....	4
7	00-124073	Leg – Rear (LH).....	1
8	00-124074-00002	Rod (Short).....	2
9	SC-094-26	Bolt ¹ / ₄ -20 x ¹ / ₂ Sq. Neck Rd. Hd.	22
10	00-205003	Caster – Locking.....	4
11	00-124070	Leg – Rear (RH)	1
12	WS-005-01	Washer.....	22
13	NS-013-02	Nut ¹ / ₄ -20 Hex	22
14	00-124074-00001	Rod (Long).....	4
15	00-124071	Leg – Front (RH).....	1
16	00-124076	Grommet.....	8
17	00-124072	Leg – Front (LH)	1
18	00-875983	Support – Cross Top	1
19	00-124069	Support – Cross Top	1
20	00-875982	Top	1

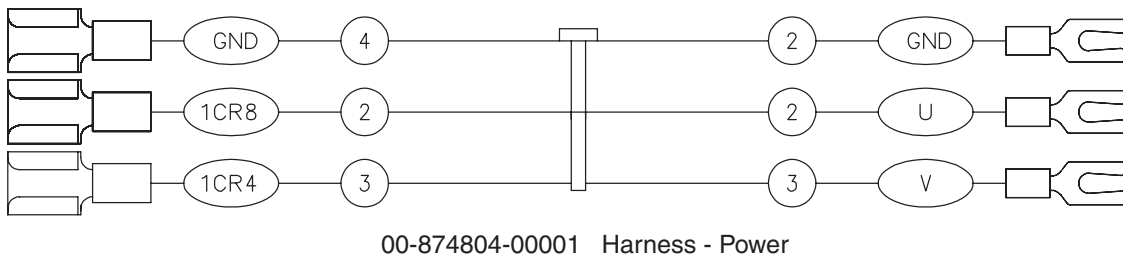
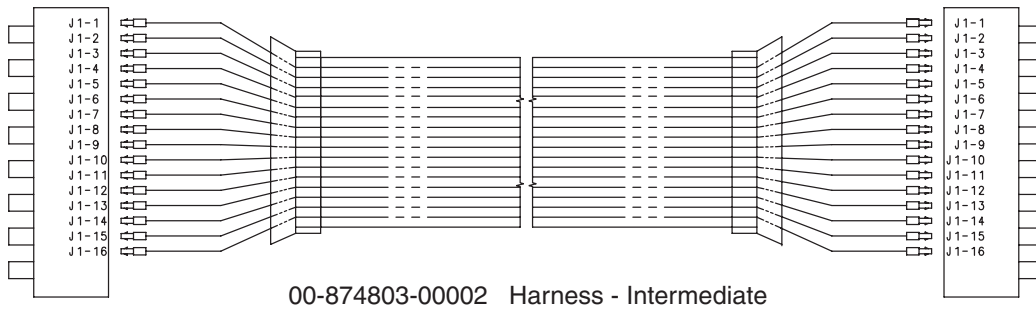
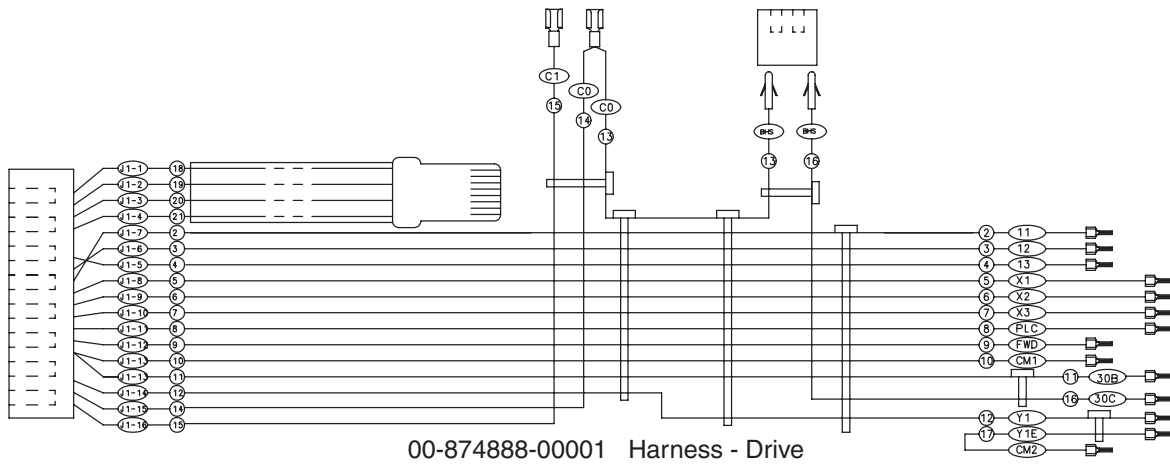

PL-58135

WIRING HARNESES

Online Parts Catalog

Note: It is helpful, but not essential to know the ML (Material List) Number of the equipment for which a part is needed

How Do I Find An ML Number?

The ML Number is found on the machine dataplate. The dataplate resembles the sample below, and is generally located on the back or side of a machine.

HOBART CORPORATION		MODEL	ML
COMMERCIAL DISHWASHER TROY, OHIO			
LISTED 756A C	UL	US	NSF
VOLTS		DATE CODE:	
HZ	PH	AMP	
749901 MADE IN U.S.A.			

- Section 1 – If Equipment ML Number is known
- Section 2 – If Equipment ML Number is not known



PRODUCT DIRECTORY | Locate an Office | Warranty Registration | Career Opportunities

SERVICE | PARTS | INSTALLATIONS | WATER TREATMENT | MANUALS & SUPPORT | CONTRACTS & PMs



Hobart Service

We're there for you, anytime you need us. 24x7.



We're within 50 miles of 95% of our service customers. Only Hobart can provide such blanket coverage because we're the premier equipment manufacturer with nearly 200 offices and 1,700

Hobart Service News & Offers

Get \$25 Off Your Next Service Call!

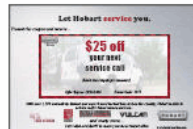

From hobartservice.com select PARTS



PRODUCT DIRECTORY | Locate an Office | Warranty Registration | Career Opportunities

SERVICE | PARTS | INSTALLATIONS | WATER TREATMENT | MANUALS & SUPPORT | CONTRACTS & PMs



Hobart Service Home > **Hobart National Parts and Accessories Program**

National Parts and Accessories Program

Hobart SmartParts® System

The [Hobart SmartParts® System](#) is an interactive parts catalog system. By entering information from your equipment's data plate, you can be assured that you are accessing the



Not Sure How to Use SmartParts™?

It's easy! Just go through the [Hobart SmartParts™ Online Tutorial](#) and you'll be a parts pro in no time!

Hobart Parts QuickLinks

- ▶ [Hobart SmartParts® System](#)
- ▶ [Parts Catalogs](#)

Next select SMARTPARTS

Web Browser Pop-up blocker must be turned off for this site in order for SmartParts to operate

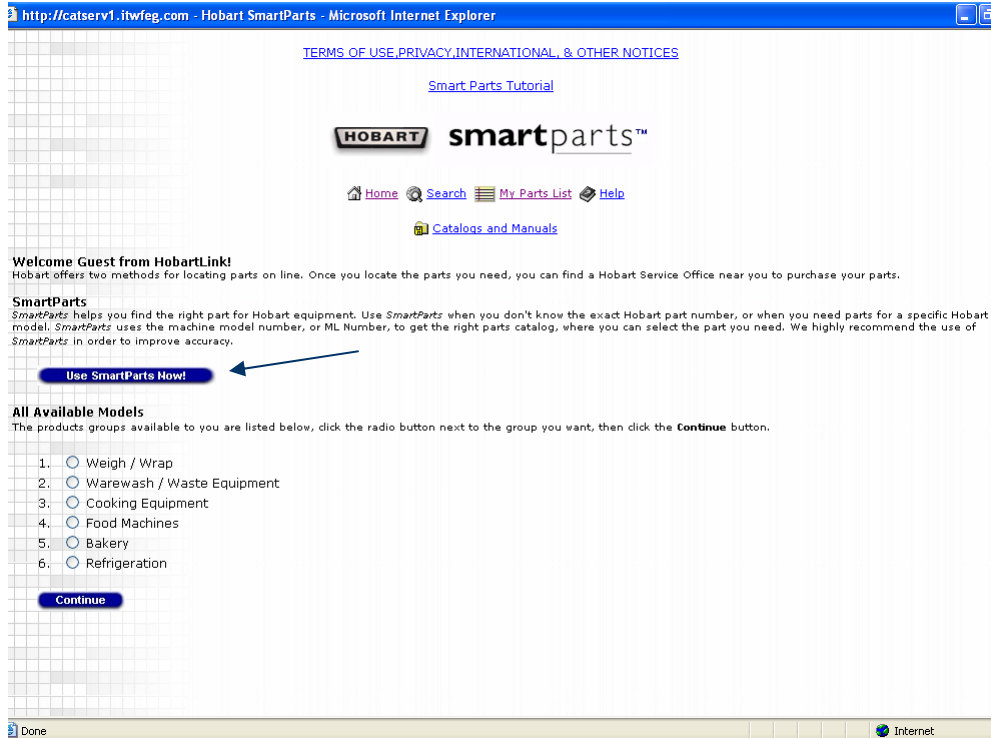

This is SmartParts home page

If the ML Number of the Equipment is known, select Use SmartParts Now

(We'll explain what to do if the ML number of the Equipment is not known in Section 2)

SmartParts

Enter Your ML Number

Enter your full or partial ML Number in the field provided, then click the **Search SmartParts!** button.

ML- **Search Smart Parts**

Enter the ML number and click on Search SmartParts

How Do I Find An ML Number?

The ML Number is found on the machine dataplate. The dataplate resembles the sample below, and is generally located on the back or side of a machine.

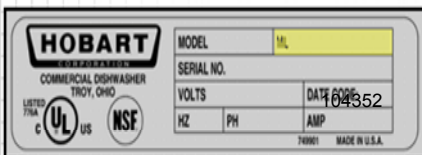

For this example, the part needed is a Water Pressure Gauge used on the LX 30 Undercounter Dishwasher

The ML number of this dishwasher is 104352

Hobart Parts Web

SmartParts

SmartParts results for **104352** (listed by product group):

Warewash / Waste Equipment

1. LX Series Dishwashers (Includes ML numbers 104349, 104350, 104351, 104352, 130016, 130017, 130018, 130019)

Continue

Go Back

Click on the Radio button to select the Parts Catalog

Then click on Continue

Assemblies Available

LX Series Dishwashers (Includes ML numbers 104349, 104350, 104351, 104352, 104353, 104354, 104355, 104356, 110380, 110381, 130016, 130017, 130018, 130019)

Click the radio button next to the assembly you want, then click the **Continue** button.

Continue

Go Back

1. BASE ASSEMBLY
2. TANK ASSEMBLY
3. DOOR ASSEMBLY
4. ELECTRICAL CONTROL DRAWER (LX SERIES)
5. ELECTRICAL CONTROL DRAWER (LXi SERIES)
6. DISPLAY
7. WASH ARM ASSEMBLY (LX18 SERIES)
8. WASH ARM ASSEMBLY (LX30/40, LXG, LXi, & LXiG SERIES)
9. WASH PIPE ASSEMBLY
10. 50 HZ., 60 HZ. PUMP AND MOTOR ASSEMBLY (INGERSOLL OR CRANE)

The Water Pressure Gauge is on the Base Assembly

Select Base Assembly

Then click on Continue

Parts List

BASE ASSEMBLY

Select an appropriate figure size

Change To:

Different Assembly

Different Product

To add an item to your parts list, click the **Add** button next to the item. To see an exploded view, click on the view figure buttons.

View Figure: @ 25% @ 50% @ 75% @ 100% ←

Add	Item	Part No.	Part Description	Qty Used On Assembly
Add	1	00-328634	Track Assy. (RH)	1
Add	2	NS-015-01	Nut 1/4-20 Hex (SST)	8
Add	3	WL-006-17	Lockwasher 1/4 Medium	8

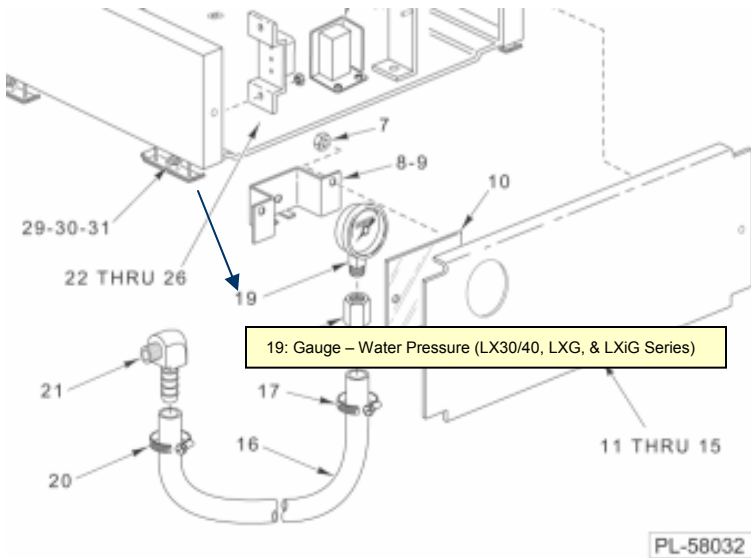

BASE ASSEMBLY

Locate the part needed (Water Pressure Gauge) on the drawing

Placing the cursor on the number will display the Description of the Part

Click on the number pointing to the part

Add	15	00-329267	Retainer - Screw #10	AR
Add	16	00-475060	Hose 1/4 x 12 Pressure Gauge to Fill Valve	1
Add	17	00-528501	Clamp - Hose #4	1
Add	18	FP-088-30	Fitting - Hose Barb (LX30/40, LXG, & LXi Series)	1
Add	19	00-918429	Gauge - Water Pressure (LX30/40, LXG, LXi, & LXiG Series)	1
Add	20	00-528501	Clamp - Hose #4	1
Add	21	FP-088-29	Fitting - Hose 1/4 Barb x 1/8-27 NPTM	1
Add	22	SC-018-24	Mach. Screw 6-32 x 3/4 Phil. Pan Hd.	2
Add	23	00-918385	Block - Terminal (5 Pole) (Current Construction)	1
Add	24	00-918339	Bracket - Terminal Block (Current Construction)	1
Add	25	NS-031-50	Stop Nut 6-32 Hex (SST)	2
Add	26	NS-031-16	Stop Nut 10-24 Hex Elastic (SST)	2
Add	27	00-475299-00001	Connector Assy. (Previous Construction)	1
Add	28	00-473138	Bracket - Terminal Block (Previous Construction)	1
Add	29	00-241857	Foot - Leveling	4
Add	30	00-329284	Spacer - Leveling Foot (LX18 Series)	4

- *Selecting the part on the figure causes the part to be highlighted on the parts list*
- *Click on the Add button to add the part to the shopping cart*
- *You can add more parts or change the quantity of the parts already in the cart*
- *When finished, click on the Confirm Parts Selected and then on Print Parts List if you want to print*

Parts Selected

Items Listed for Guest

Add More Items From:

There is 1 item in your parts list:

Delete	Qty. Req.	Part No.	Part Description	Parts List
<input type="button" value="Delete"/>	<input type="text" value="1"/>	00-918429	Gauge - Water Pressure (LX30/40, LXG, LXi, & LXiG Series)	BASE ASSEMBLY

Use **SMARTPARTS** Now

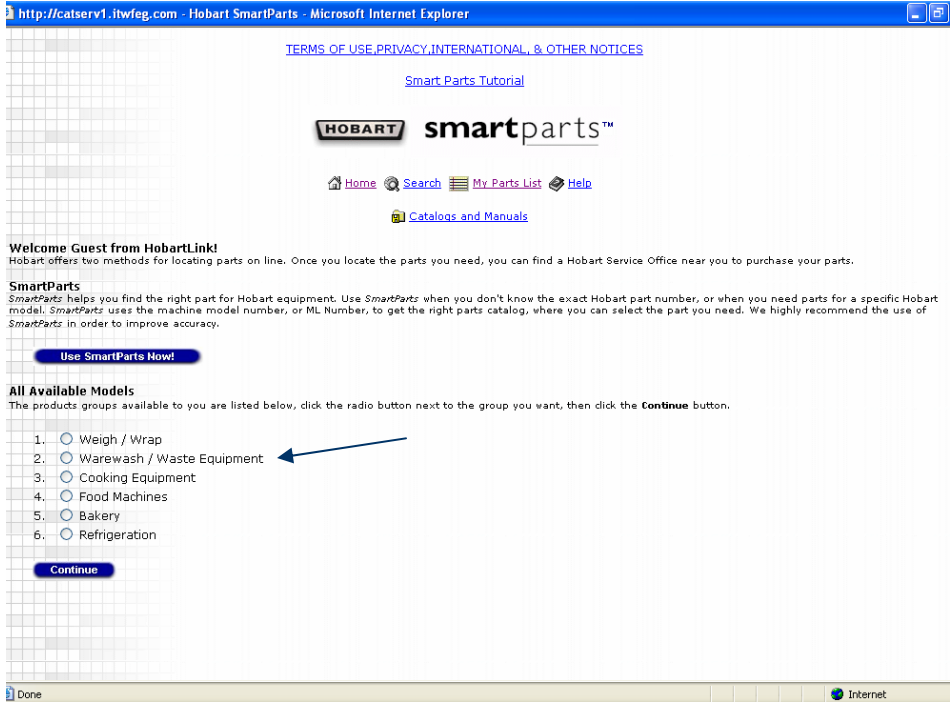

This (again) is SmartParts home page

For this example, the part needed is a Water Pressure Gauge used on the LX 30 Undercounter Dishwasher

If the ML Number of the Equipment is not known, click on the Radio button to select Warewash / Waste Equipment

Then click on Continue

(Go to Section 1 if you do know the ML number of the Equipment)

Section 2 – If Equipment ML Number is not known

Products Available

Warewash / Waste Equipment

Click the radio button next to the product you want, then click the **Continue** button.

Continue **Go Back**

- 1. Door Type Dishwasher
- 2. Booster
- 3. Conveyor Type Dishwasher (C-LINE)
- 4. Flight Type Dishwasher
- 5. Miscellaneous Warewash
- 6. UnderCounter Dishwasher (indicated by a blue arrow)
- 7. Waste Equipment

Continue **Go Back**

Click on the Radio button to select UnderCounter Dishwasher

Then click on Continue

Parts Catalogs

UnderCounter Dishwasher

Click the radio button next to the catalog you want, then click the **Continue** button.

Continue **Go Back**

- LX Series Dishwashers (Includes ML numbers 104349, 104350, 104351, 104352, 104353, 104354, 104355, 104356, 110380, 110381, 130016, 130017, 130018, 130019)
- WM Series Dishwashers
- Dishwasher Motor Book (Includes the following Motor Spec /ML numbers - 9257, 6661, 8115, 17829, 18897, 18751, 18931, 18930, 18932, 31219, 31220, 31221, 18491, 17350, 9801, 18603)
- SR24 Series Dishwasher (SR24C - ML-130021, SR24H - ML-130022)
- Fast Food Warewashers

Continue **Go Back**

Click on the Radio button to select LX Series Dishwashers

Then click on Continue

Assemblies Available

LX Series Dishwashers (Includes ML numbers 104349, 104350, 104351, 104352, 104353, 104354, 104355, 104356, 110380, 110381, 130016, 130017, 130018, 130019)

Click the radio button next to the assembly you want, then click the **Continue** button.

Continue **Go Back**

- BASE ASSEMBLY
- TANK ASSEMBLY
- DOOR ASSEMBLY
- ELECTRICAL COMPONENTS(LX SERIES)
- ELECTRICAL COMPONENTS (LXi SERIES)
- DISPLAY
- WASH AND RINSE ARM ASSEMBLY(lx30/40, lxxg, lxi, & lxiig SERIES)(PREV. CONSTR.)
- WASH AND RINSE ARM ASSEMBLY(lx30/40, lxxg, lxi, & lxiig SERIES)(CURRENT CONSTR.)
- WASH ARM ASSEMBLY(LX18 SERIES)
- WASH PIPE ASSEMBLY (PREVIOUS CONSTRUCTION)
- WASH PIPE ASSEMBLY (CURRENT CONSTRUCTION)

The Water Pressure Gauge is on the Base Assembly

Select Base Assembly

Then click on Continue

Parts List

BASE ASSEMBLY

Select an appropriate figure size

Change To:

Different Assembly

Different Product

To add an item to your parts list, click the **Add** button next to the item. To see an exploded view, click on the view figure buttons.

View Figure: @ 25% @ 50% @ 75% @ 100% ←

Add	Item	Part No.	Part Description	Qty Used On Assembly
Add	1	00-328634	Track Assy. (RH)	1
Add	2	NS-015-01	Nut 1/4-20 Hex (SST)	8
Add	3	WL-006-17	Lockwasher 1/4 Medium	8

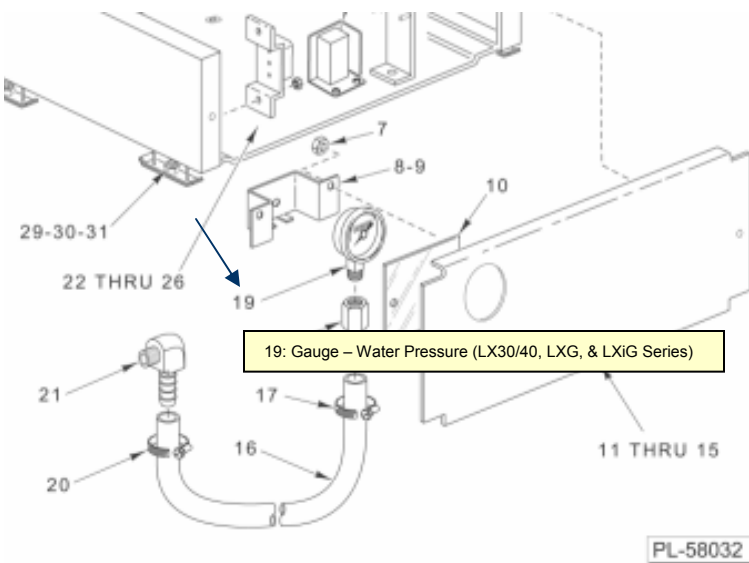

Locate the part needed (Water Pressure Gauge) on the drawing

Placing the cursor on the number will display the Description of the Part

Click on the number pointing to the part

BASE ASSEMBLY

Add	15	00-329267	Retainer - Screw #10	AR
Add	16	00-475060	Hose 1/4 x 12 Pressure Gauge to Fill Valve	1
Add	17	00-528501	Clamp - Hose #4	1
Add	18	FP-088-30	Fitting - Hose Barb (LX30/40, LXG, & LXI Series)	1
Add	19	00-918429	Gauge - Water Pressure (LX30/40, LXG, LXI, & LXIG Series)	1
Add	20	00-528501	Clamp - Hose #4	1
Add	21	FP-088-29	Fitting - Hose 1/4 Barb x 1/8-27 NPTM	1
Add	22	SC-018-24	Mach. Screw 6-32 x 3/4 Phil. Pan Hd.	2
Add	23	00-918385	Block - Terminal (5 Pole) (Current Construction)	1
Add	24	00-918339	Bracket - Terminal Block (Current Construction)	1
Add	25	NS-031-50	Stop Nut 6-32 Hex (SST)	2
Add	26	NS-031-16	Stop Nut 10-24 Hex Elastic (SST)	2
Add	27	00-475299-00001	Connector Assy. (Previous Construction)	1
Add	28	00-473138	Bracket - Terminal Block (Previous Construction)	1
Add	29	00-241857	Foot - Leveling	4
Add	30	00-329284	Spacer - Leveling Foot (LX18 Series)	4

- *Selecting the part on the figure causes the part to be highlighted on the parts list*
- *Click on the Add button to add the part to the shopping cart*
- *You can add more parts or change the quantity of the parts already in the cart*
- *When finished, click on the Confirm Parts Selected and then on Print Parts List if you want to print*

Parts Selected

Items Listed for Guest

Add More Items From:

Current Assembly

Different Assembly

Different Product

There is 1 item in your parts list:

Delete	Qty. Req.	Part No.	Part Description	Parts List
Delete	<input type="text" value="1"/>	00-918429	Gauge - Water Pressure (LX30/40, LXG, LXI, & LXIG Series)	BASE ASSEMBLY

Update Quantities

Confirm Parts Selected

Use **SMARTPARTS** Now



RECOMMENDED SPARE PARTS LIST

HL200 LEGACY MIXER

Qty	Part Number	Description
1	23482	Seal, Grease
1	087711-352	Switch, Reed
1	087714-42-5	Relay
1	114695	Seal, Oil
1	874809	Knob
1	937164-1	Carrier, Wire Cage
1	937164-2	Carrier, Wire Cage Slotted
1	937061	Switch, Speed Selector
1	917529	Housing, Magnet
1	917358	Holder, Lower
1	917357	Holder, Upper
1	874875	Magnet, Disc
1	937135	PBC, Timer
1	OR 001-03	Quad Ring