

HAOF-90

Holmes

BLIZZARD™ OSCILLATING FAN



Owner's Guide

PLEASE READ AND SAVE THESE INSTRUCTIONS

IMPORTANT INSTRUCTIONS

When using electrical appliances, basic safety precautions should always be taken including the following:

- Use fan only for purposes described in the instruction manual.
- To protect against electrical shock do not immerse unit, plug or cord in water or spray with liquids.
- Close supervision is necessary when any appliance is used by or near children.
- Unplug from outlet when not in use, when moving fan from one location to another, before putting on or taking off parts, and before cleaning.
- Avoid contact with moving parts.
- Do not operate in the presence of explosive and/or flammable fumes.
- Do not place fan or any parts near an open flame, cooking or other heating appliance.
- Do not operate any appliance with a damaged cord, plug, after the appliance malfunctions, or has been dropped/ damaged in any manner.
- The use of attachments not recommended or sold by the appliance manufacturer may cause hazards.
- Do not use outdoors.
- Do not let the cord hang over the edge of a table, counter, or come in contact with hot surfaces.
- To disconnect, grip plug and pull from wall outlet. Never yank on cord.
- Always use on a dry, level surface.
- Do not operate without fan grills properly in place.
- This product is intended for household use ONLY and not for commercial or industrial applications.

WARNING: To reduce the risk of fire or electrical shock, DO NOT USE THIS FAN with any SOLID STATE Fan Speed Control Device

PLEASE READ AND SAVE THESE INSTRUCTIONS

THIS PRODUCT IS EQUIPPED WITH A POLARIZED A.C. (Alternating Current) PLUG (a plug having one blade wider than the other). This plug will fit into the power outlet only one way. This is a safety feature. If you are unable to insert the plug fully into the outlet, try reversing the plug. If the plug should still fail to fit, contact an electrician to replace the obsolete outlet. DO NOT DEFEAT THE SAFETY PURPOSE OF THIS POLARIZED PLUG



MOUNTING LOCATION GUIDE

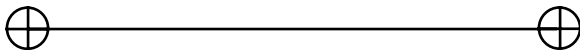

Use this diagram to help properly line up screws.

Assembly Instructions:

The Blizzard™ Oscillating Fan comes completely assembled and ready for immediate use. Carefully unpack your fan, refer to the operating instructions below and enjoy!

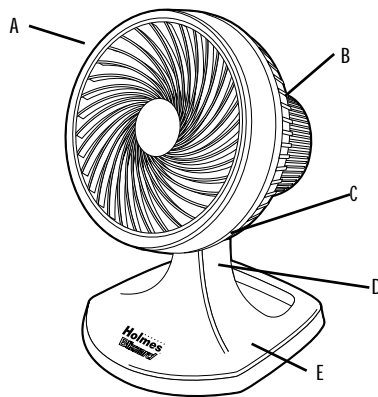

Figure 1

- A) Fan Head
- B) Speed and Oscillation Controls (not visible)
- C) Wall-Mount Lock (not visible)
- D) Fan Neck
- E) Fan Base

Operating Instructions

To Use Your Fan In A Table Position:

- STEP 1: Set fan on a dry, level surface.
- STEP 2: Plug cord into any standard 120 volt AC outlet. Please make sure the Speed Control Knob is in the OFF position.
- STEP 3: The Speed Control Knob is located on the back of the fan motor housing. The speed is adjusted by turning the control knob to the desired setting, 0 for Off, III for High, II for Medium, and I for Low.

To Use Your Fan In A Wall-Mounted Position:

- STEP 1: Wall-Mount according to instructions below.
- STEP 2: The power cord can drape directly down around the neck of the fan. Plug cord into any standard 120 volt AC outlet. Please make sure the Speed Control Knob is in the OFF position.
- STEP 3: The Speed Control Knob is located on the back of the fan motor housing. The speed is adjusted by turning the control knob to the desired setting, 0 for Off, III for High, II for Medium, and I for Low.

MOUNTING LOCATION GUIDE

Use this diagram to help properly line up screws.

Adjustment/Assembly Instructions

Oscillation Control:

The Oscillation Control Switch is located on the top of the motor housing. Push the switch down for oscillation, or pull the switch up for operation in a stationary position.

Table Position:

The Blizzard™ Oscillating Fan is designed to operate as a table fan from 3 different positions. To adjust the direction of the fan, hold onto the front of the fan head with both hands, and gently push to the desired position.

Wall-Mount Position:

The Blizzard™ Oscillating Fan is designed to operate from 4 different positions while wall-mounted. The first 3 positions are set by gently pushing the fan head to the desired location. To set the fan in the fourth and furthest back position, press down firmly on the wall-mount lock at the back of the fan neck with one hand, while pushing the fan head back into the fourth position with your other hand.

Please Note: When taking the fan down from the wall and changing to table fan operation, make sure to pull the fan head forward out of the fourth wall-position. Pull gently forward until you hear the wall-mount lock secure the fan back into table mode. You will then have the 3 standard table fan positions available to choose from.

STEP 1: After selecting a suitable location on the wall, use the mounting location guide below to ensure proper placement.

STEP 2: Use the holes as a guide and mark the correct place where the screws will be inserted. Consult with a Hardware or Home Center for the best screws for your type of wall.

STEP 3: Secure the screws almost all the way into the wall using a screw-driver.

STEP 4: Line up the holes on the back of the unit with the screws to hang your fan. Make sure the screws are securely screwed into the wall before carefully placing the fan on them.

Fan Head Cleaning:

Using a soft, moist cloth, with or without a mild, soap solution, carefully clean the fan head. Please use caution around the motor housing area. Do not allow the motor or other electrical components to be exposed to water. DO NOT ATTEMPT TO REMOVE THE FAN BLADE.

FAN STORAGE:

Your fan can be stored in the off-season either partially disassembled or assembled. It is important to keep it in a safe, dry location.

- If stored disassembled, we recommend using the original (or appropriately sized) box.
- Remember to protect the fan head from dust. The exclusive Holmes Products Fan Bonnet is available to safeguard your fan. (See attached mail order form for special offer or call 1-800-5-HOLMES)

FAN SERVICE INSTRUCTIONS:

1. Do NOT attempt to repair or adjust any electrical or mechanical functions on this unit. Doing so will void the warranty.
2. If you have any questions regarding this unit's operation or believe any repair is necessary, please call 1-800-5-HOLMES to speak with a Customer Service Representative.

3. If you need to exchange the unit, please return it in its original carton, with a sales receipt, to the store where you purchased it. If you are returning the unit more than 30 days after the date of purchase, please see the enclosed warranty.

4. If you have any other questions or comments, feel free to write us:

The Holmes Group, Inc.
P.O. Box 769
Milford, MA 01757

For your own records, staple or attach your sales receipt to this manual. Also, please take a moment to write the store name/location and date purchased below.

STORE NAME

LOCATION:

DATE PURCHASED:

(STAPLE RECEIPT HERE)

Three (3) Year Limited Warranty

SAVE THIS WARRANTY INFORMATION

- A. The quality controls used in the manufacture of this Holmes® product are to ensure your satisfaction.
- B. The Warranty Registration Card enclosed with this product must be completed and returned within 10 days of purchase for your Warranty to be effective. This Warranty applies only to the original purchaser of this product.
- C. This Warranty applies ONLY to repair or replacement of any supplied or manufactured parts of this product that, upon inspection by Holmes authorized personnel, proves to have failed in normal use due to defects in material or workmanship. Holmes will determine whether to repair or replace the unit. This Warranty does not apply to installation expenses.
- D. Operating this unit under conditions other than those recommended or at voltages other than the voltage indicated on the unit, or attempting to service or modify the unit, will render this WARRANTY VOID.
- E. Unless otherwise proscribed by law, Holmes shall not be liable for any personal injury, property or any incidental or consequential damages of any kind (including water damage) resulting from malfunctions, defects, misuse, improper installation or alteration of this product.
- F. All parts of this Holmes product are guaranteed for a period of 3 year as follows:
 - 1. Within the first 30 days from date of purchase, the store from which you purchased your Holmes product should replace this product if it is defective in material or workmanship (provided the store has in-stock replacement.)
 - 2. Within the first thirty-six months from date of purchase, subject to the conditions in paragraph H, Holmes will repair or replace the product if it is defective in material or workmanship providing it is returned to Holmes, freight prepaid, with PROOF OF PURCHASE date, together with \$5.00 for return shipping and handling charges.
- G. If you have any problem with this product, please write our Customer Service Dept., or call, 1-800-5-HOLMES.
- H. **IMPORTANT RETURN INSTRUCTIONS** Your warranty depends on your following these instructions if you are returning the unit more than 30 days after the date of purchase:
 - 1. Carefully pack the item in its original carton or other suitable box to avoid damage in shipping.
 - 2. Before packing your unit for return; be sure to enclose:
 - a) your name, full address with zip code and telephone number,
 - b) a dated sales receipt or PROOF OF PURCHASE,
 - c) your \$5.00 check for return shipping and handling, and
 - d) the model number of the unit and the problem you are having.
(Enclose in an envelope and tape directly to the unit before the box is sealed.)
 - 3. All shipping charges must be prepaid by you (as noted in paragraph F).
 - 4. Ship to: THE HOLMES GROUP, INC., CUSTOMER RETURNS, 2 PULLMAN STREET, WORCESTER, MA 01606

SHIPPING AND HANDLING CHARGES: \$5.00

This warranty gives you specific legal rights, and you may have other rights which vary from state to state. The provisions of this warranty are in addition to, and not a modification of, or subtraction from, the statutory warranties and other rights and remedies contained in any applicable legislation. To the extent that any provision of this warranty is inconsistent with any applicable law, such provision shall be deemed voided or amended, as necessary, to comply with such law.