

Homelite®

OPERATOR'S MANUAL Trimmer / Brushcutter

F3040

UT70131

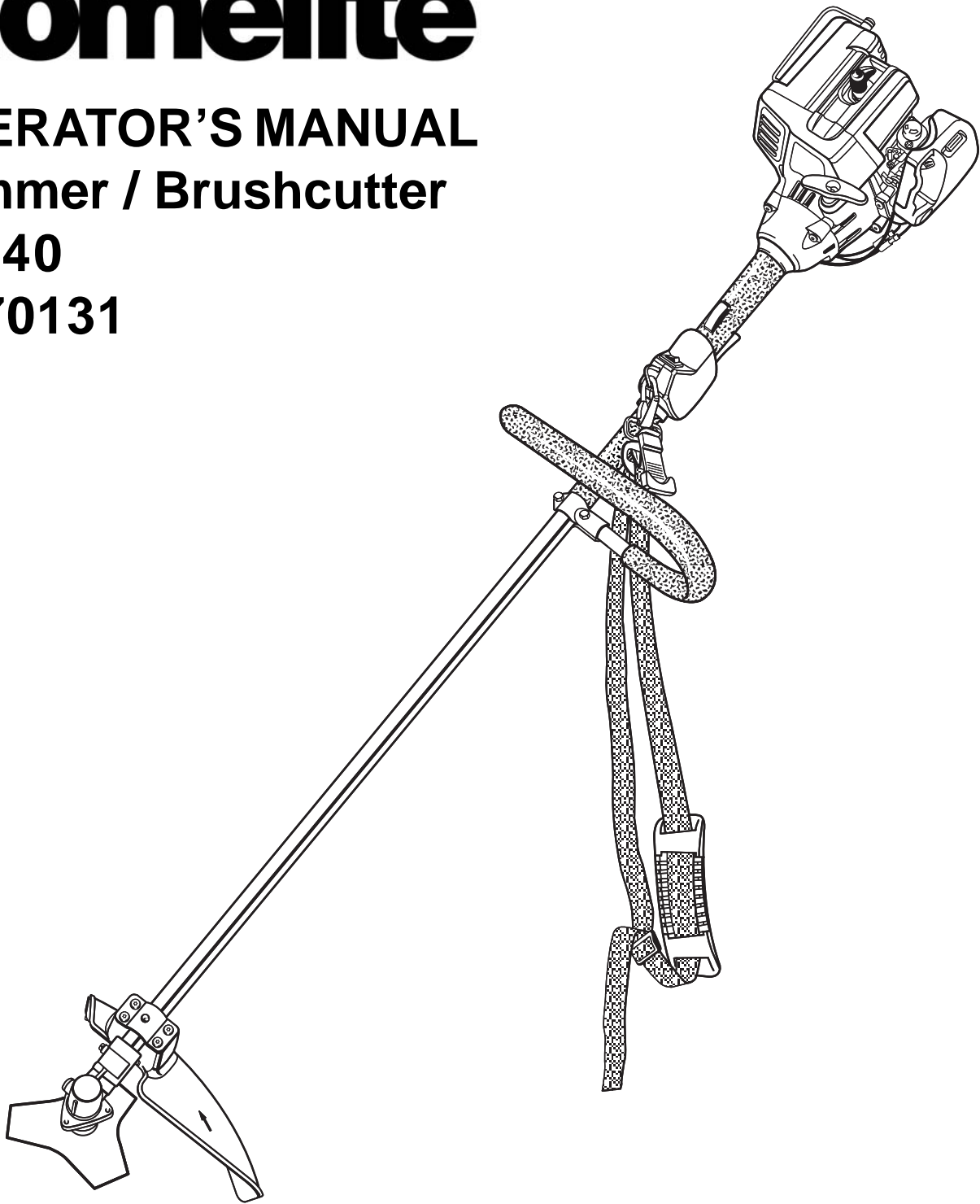

Your new trimmer has been engineered and manufactured to Homelite's high standard for dependability, ease of operation, and operator safety. Properly cared for, it will give you years of rugged, trouble-free performance.



WARNING: To reduce the risk of injury, the user must read and understand the operator's manual.

Thank you for buying a Homelite trimmer.

SAVE THIS MANUAL FOR FUTURE REFERENCE

TABLE OF CONTENTS

■ Safety	2 - 3
■ Symbols	4 - 5
■ Technical Data	5
■ Unpacking	6
■ Features	6
■ Assembly	7 - 10
■ Operation	11 - 14
■ Maintenance	15 - 18
■ Troubleshooting	19 - 20
■ Warranty	21
■ Safety Directive	21

SAFETY

WARNING:

Do not attempt to operate this trimmer until you have read thoroughly and understand completely all instructions, safety rules etc contained in this manual. Failure to comply may result in accidents involving fire, electric shock or serious personal injury. Save operator's manual and review frequently for continuing safe operation, and instructing others who may use this tool.

READ ALL INSTRUCTIONS

GENERAL SAFETY RULES

- For safe operation, read and understand all instructions before using the trimmer/brushcutter. Follow all safety instructions. Failure to follow all safety instructions listed below can result in serious personal injury.
- Do not allow children or untrained individuals to use this unit.
- Never start or run the engine in a closed or poorly ventilated area; breathing exhaust fumes can kill.
- Clear the work area before each use. Remove all objects such as stones, broken glass, nails, wire or string which can be thrown or become entangled in the string head or blade.
- Wear full eye and hearing protection while operating this unit.
- Wear heavy long trousers, boots and gloves. Do not wear loose fitting clothing, shorts, jewellery of any kind, or go barefoot.
- Secure long hair so it is above shoulder level to prevent entanglement in any moving parts.
- Keep all bystanders, children and pets at least 15 m (50 ft) away.
- Do not operate this unit when you are tired, ill or under the influence of alcohol, drugs or medication.
- Do not operate in poor lighting.
- Keep firm footing and balance. Do not overreach. Overreaching can result in loss of balance or exposure to hot surfaces.
- Keep all parts of your body away from any moving part.
- Do not touch area round the silencer or cylinder of the trimmer/brushcutter, these parts get hot from operation.
- Always stop the engine and remove the sparking plug wire before making any adjustments or repairs except for carburettor adjustments.

SAFETY

- Inspect the unit before each use for loose fasteners, fuel leaks etc. Replace any damaged parts before use.
- The string head or blade will rotate during carburettor adjustments.
- It has been reported that vibrations from hand-held tools may contribute to a condition called Raynaud's Syndrome in certain individuals. Symptoms may include tingling, numbness and blanching of the fingers, usually apparent upon exposure to cold. Hereditary factors, exposure to cold and dampness, diet, smoking and work practices are all thought to contribute to the development of these symptoms. It is not known at present what, if any, vibrations or extent of exposure may contribute to the condition. There are measures which can be taken by the operator to possibly reduce the effects of vibration:
 - a) Keep your body warm in cold weather. When operating the unit wear gloves to keep the hands and wrists warm. It is reported that cold weather is a major factor contributing to Raynaud's Syndrome.
 - b) After each period of operation, exercise to increase blood circulation.
 - c) Take frequent work breaks. Limit the amount of exposure per day.
 - d) Keep the tool well maintained, fasteners tightened and worn parts replaced.

If you experience any of the symptoms of this condition, immediately discontinue use and see your doctor about these symptoms.

- Mix and store fuel in a container approved for petrol.
- Mix fuel outdoors where there are no sparks or flames. Wipe up any fuel spillage. Move 9 m (30 ft) away from refuelling site before starting engine.
- Stop the engine and allow to cool before refuelling or storing the unit.
- Allow the engine to cool; empty the fuel tank and secure the unit from moving before transporting in a vehicle.

SPECIFIC SAFETY RULES FOR TRIMMER USE













- Replace string head if cracked, chipped or damaged in any way. Be sure the string head or blade is properly installed and securely fastened. Failure to do so can cause serious injury.
- Make sure all guards, straps, deflectors and handles are properly and securely attached.
- Use only the manufacturer's replacement string in the cutting head. Do not use any other cutting attachment.
- Never operate unit without the grass deflector in place and in good condition.
- Maintain a firm grip on both handles while trimming. Keep string head below waist level. Never cut with the string head located over 76 cm (30 in) or more above the ground.

SPECIFIC SAFETY RULES FOR BRUSHCUTTER AND BLADE USE

- After engine stops, keep rotating blade in heavy grass or pulpy weeds until it stops.
- Do not operate the brushcutter unless the blade guard is firmly secured in place and in good condition.
- Use heavy gloves while installing or removing blades.
- Always stop the engine and remove the sparking plug wire before attempting to remove any obstruction caught or jammed in the blade or before removing and installing the blade.
- Do not attempt to touch or stop the blade when it is rotating.
- A coasting blade can cause injury while it continues to spin after the engine is stopped or throttle trigger released. Maintain proper control until the blade has completely stopped rotating.
- Replace any damaged blade. Always make sure blade is installed correctly and securely fastened before each use. Failure to do so may cause serious injury.
- Use only the manufacturer's replacement TRI-ARC blade intended for use on this brushcutter. Do not use any other blade.
- The TRI-ARC blade is suited for cutting pulpy weeds and vines only. Do not use for any other purpose. Never use the TRI-ARC blade to cut woody brush.
- Exercise extreme caution when using the blade with this unit. Blade thrust is the reaction which may occur when the spinning blade contacts anything it cannot cut. This contact may cause the blade to stop for an instant, and suddenly "thrust" the unit away from the object that was hit. This reaction can be violent enough to cause the operator to lose control of the unit. Blade thrust may occur without warning if the blade snags, stalls or binds. This is more likely to occur in areas where it is difficult to see the material being cut. For cutting ease and safety, approach the weeds being cut from the right to the left. In the event that an unexpected object or woody stock is encountered, this could minimise the blade thrust reaction.
- Never cut any material over 13 mm (1/2 in) diameter.
- Always wear the shoulder strap when using the brushcutter and adjust to a comfortable operating position. Maintain a firm grip on both handles while cutting with a blade. Keep the blade away from body and below waist. Never use the brushcutter with the blade located 76 cm (30 in) or more above the ground level.

SYMBOLS

Important: Some of the following symbols may be used on your tool. Please study them and learn their meaning. Proper interpretation of these symbols will allow you to operate the tool better and more safely.

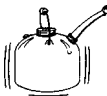
SYMBOL	NAME	EXPLANATION
	Safety Alert Symbol	Indicates danger, warning or caution. It means attention!!! Your safety is involved.
	Read Your Operator's Manual	Your manual contains special messages to bring attention to potential safety concerns as well as operating and servicing information. Please read all the information carefully to ensure satisfaction and safe use.
	Wear eye and hearing protection	Wear eye and hearing protection when operating this equipment.
	Keep bystanders away	Keep all bystanders at least 15 m (50 ft) away.
	Ricochet	Danger of Ricochet.
	Tri-Arc blade	Tri-Arc blade is appropriate for this unit and is suited for cutting pulpy weeds and vines.
	Do not use toothed blade	This unit is not intended for use with a toothed saw type blade.
	RPM Decal	Rotational direction and maximum speed of the shaft for the cutting attachment.
	Boots	Wear non-slip safety footwear when using this equipment.
	Gloves	Wear non-slip, heavy-duty gloves.
	No Smoking	Do not smoke when mixing fuel or filling fuel tank.
	Petrol	Use unleaded petrol intended for motor vehicle use with an octane rating of 87 ([R + M] / 2) or higher.
	Oil	Use 2-cycle oil for air cooled engines.
	Mix Petrol and Oil	Mix the fuel mix thoroughly and also each time before refuelling.

SYMBOLS

SYMBOL	NAME	EXPLANATION
	Switch	On/Off Switch I = ON to Run O = OFF to Stop

The purpose of safety symbols is to attract your attention to possible dangers. The safety symbols and the explanations with them deserve your careful attention and understanding. The safety warnings do not by themselves eliminate any danger. The instructions or warnings they give are not substitutes for proper accident prevention measures.

SYMBOL MEANING



DANGER: Indicates an imminently hazardous situation which, if not avoided, will result in death or serious injury.



WARNING: Indicates a potentially hazardous situation which, if not avoided, could result in serious injury.



CAUTION: Indicates a potentially hazardous situation which, if not avoided, may result in minor or moderate injury. It may also be used to alert against unsafe practices which may cause property damage.

NOTE: Advises you of information or instructions vital to the operation or maintenance of the equipment.

SAVE THESE INSTRUCTIONS

TECHNICAL DATA

Weight	Without fuel, cutting attachment	5.48 Kg
	With blade	5.80 Kg
	With string head	5.67 Kg
Fuel tank volume		42.5 cm ³
Cutting swath		457 mm
Engine displacement		25 cm ³
Maximum engine performance (in accordance with ISO 8893)		0.75 kW
Maximum rotational frequency of the spindle		10,000/min ⁻¹
Engine Speed (rotational frequency) at recommended max. spindle rotational frequency		12,500/min ⁻¹
Engine speed (rotational frequency) at idle		2,000 - 2,500/min ⁻¹
Fuel consumption (in accordance with ISO 8893) at max. engine performance		0.48 kg/h
Specific fuel consumption (in accordance with ISO 8893) at max. engine performance		0.46 kg/h
Vibration level idling	Front Handle	3.0
	Rear Handle	3.1
Vibration level racing	Front Handle	5.0
	Rear Handle	10.5
Sound pressure level (in accordance with EN ISO 11806:1997, ISO 7917:1987)		100
Sound power level (in accordance with ISO 10884)		112

UNPACKING

INSTRUCTIONS

- Carefully remove the product from the carton.
- Inspect the product to make sure no breakage or damage occurred during carriage.
- Do not discard the packing material until you have inspected and operated the product.

PACKING LIST FOR OWNER'S KIT

- Grass deflector
- Blade guard
- Tri-Arc blade
- Shoulder strap
- Silencer guard, torque wrench and screws
- Front "J" handle
- Holding pin
- Spanners - 13 mm (1/2 in) and 16 mm (5/8 in)
- Fixings
- Operator's manual

FEATURES

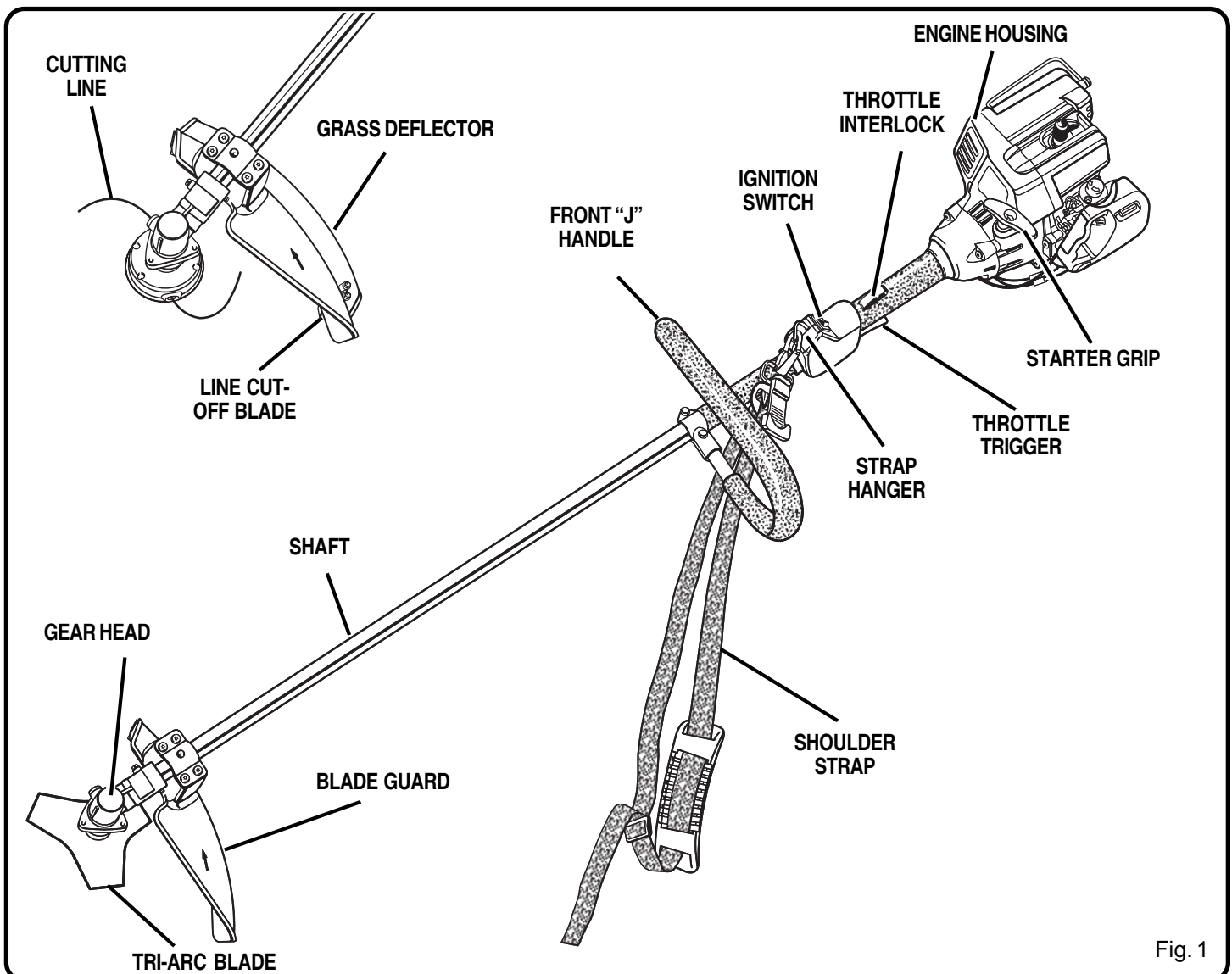

Fig. 1

ASSEMBLY

FRONT HANDLE

See Figure 2.

A barrier handle should be used for ensuring the best control and maximising operator safety.

1. Hold the top and bottom clamp snugly in position on the shaft housing so that handle will be located to the operator's left.
2. Insert the end of the handle between the clamps.
3. Align the bolt holes and push the long bolt (1/4-20 x 1 1/2 in) through the handle side.
4. Place short bolt (1/4-20 x 1 in) through opposite side of clamp. Install flat washer, lock washers and hex nuts to hold the assembly in place.
5. After assembly is complete, adjust the position of the handle for best balance and comfort.
6. Tighten first the long bolt and then the short bolt.
7. Connect the shoulder strap to the strap hanger adjust to a comfortable position.

NOTE: Do not attempt to remove or modify the spacer. This spacer limits the upper position of the handle grip. See Figure 4.

ATTACHING THE SHOULDER STRAP

See Figure 3.

1. Connect the latch on the shoulder strap to the strap hanger.
2. Adjust the strap to a comfortable position.

NOTE: To quickly release the product from the shoulder strap, sharply pull the quick release tab.

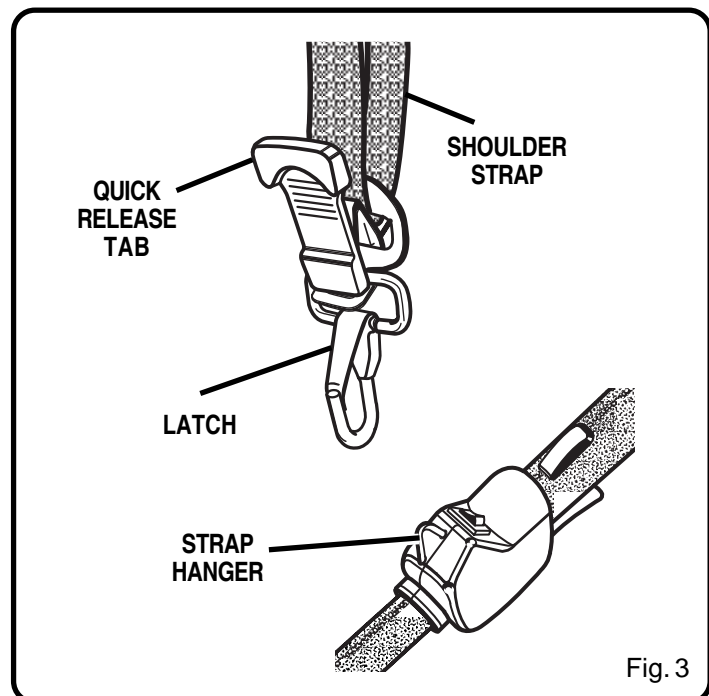
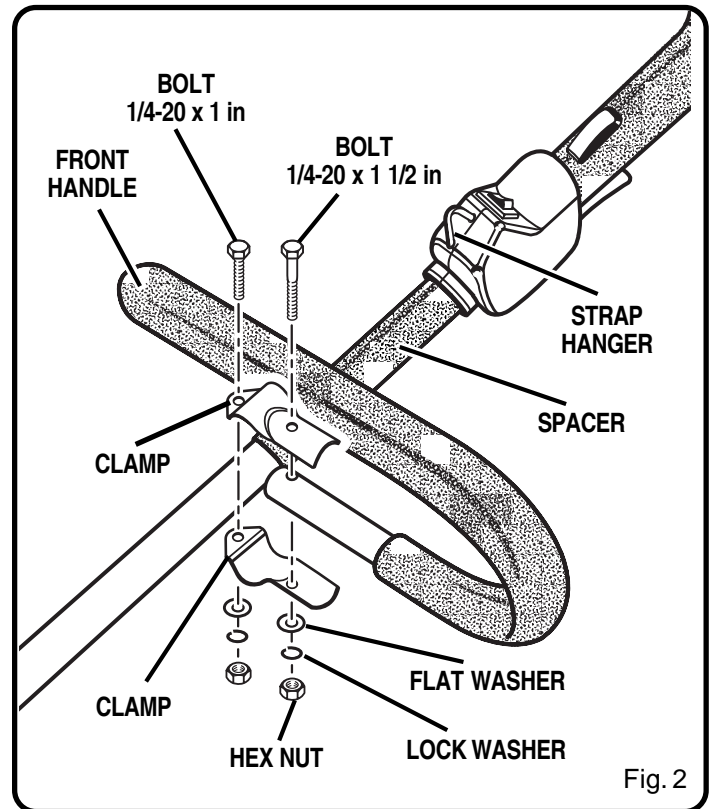

ASSEMBLY

SILENCER GUARD ASSEMBLY

See Figure 4.

1. Remove silencer guard and two screws from the owner's kit.
2. Attach the silencer guard to the rear housing.
NOTE: Make sure the bent end of the silencer guard fits securely into the opening of the rear housing.
3. Install two screws.
4. Tighten screws securely.

GRASS DEFLECTOR AND BLADE GUARD USE

See Figure 5.

NOTE: When converting from brushcutter to trimmer, or trimmer to brushcutter, make sure the correct guard/deflector is being used.

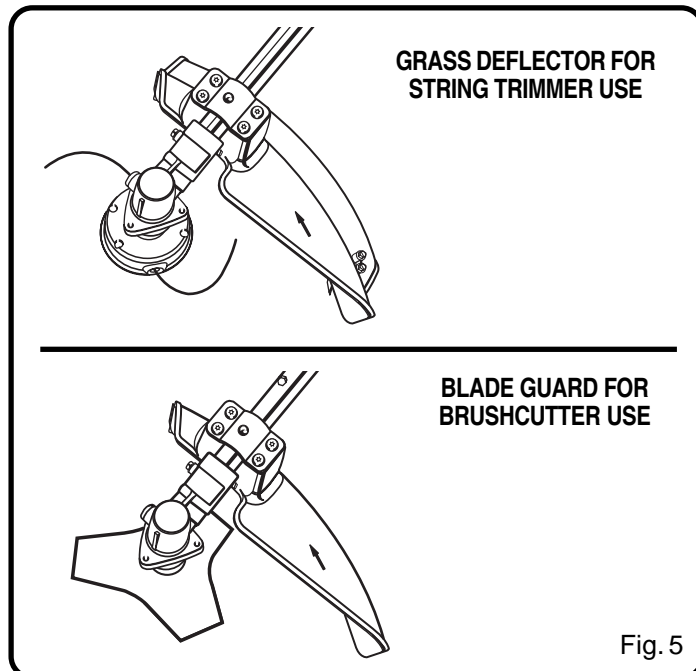
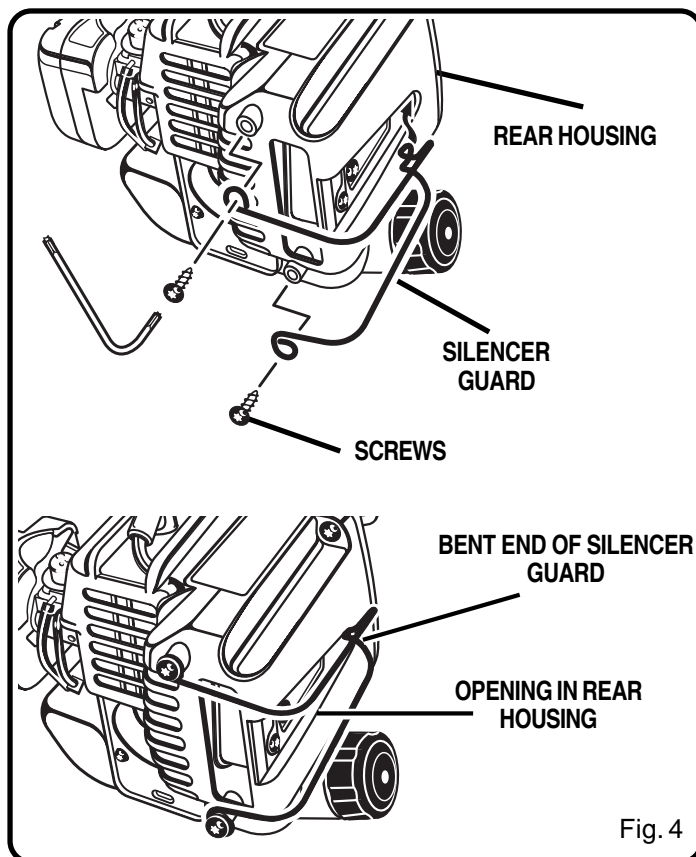

ASSEMBLY

BLADE GUARD

See Figure 6.

1. Attach the blade guard to the mounting bracket; install the four screws (10-24 x 3/4 in) from the top of the mounting bracket through the blade guard and into the threaded mounting plates.
2. Using the torque wrench supplied, tighten all four screws securely.

NOTE: When using the string head, the string shield must be attached to blade guard.

GRASS DEFLECTOR

See Figure 6.

1. Attach the grass deflector to the blade guard by placing the three locking tabs into the three notches.
2. Snap the blade guard and grass deflector together to lock into place.

⚠ WARNING:

Always stop the engine and remove the sparking plug wire before making any adjustments such as changing cutting heads; this is to reduce the risk of serious personal injury.

CONVERTING FROM TRIMMER TO BRUSHCUTTER

REMOVING THE STRING HEAD

See Figure 7.

1. Align the slot in the upper flange washer with the hole in the gear head. Place the holding pin through the slot in the upper flange washer and the hole in the gear head. Turn the spool retainer clockwise to remove. Remove the spool and string head from the drive connector.
2. Place the holding pin through the upper flange washer and the gear head. Using the 16 mm (5/8 in) spanner supplied, turn the drive connector clockwise to remove.
3. Remove the upper flange washer from the gear shaft and retain for blade installation.
4. Remove the grass deflector by pushing in on the three locking tabs while pulling on the grass deflector to separate from the blade guard.

NOTE: Store the string head parts together for later use.

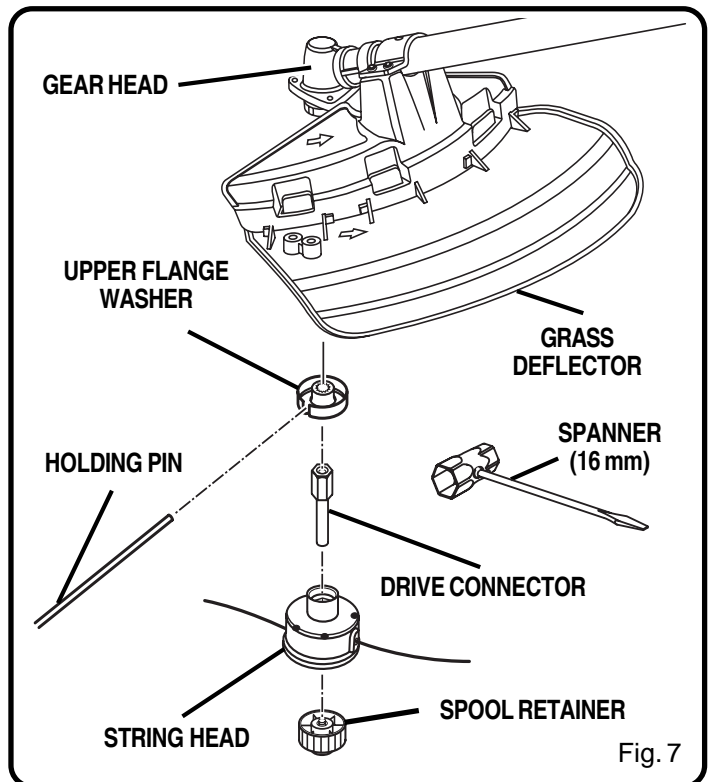
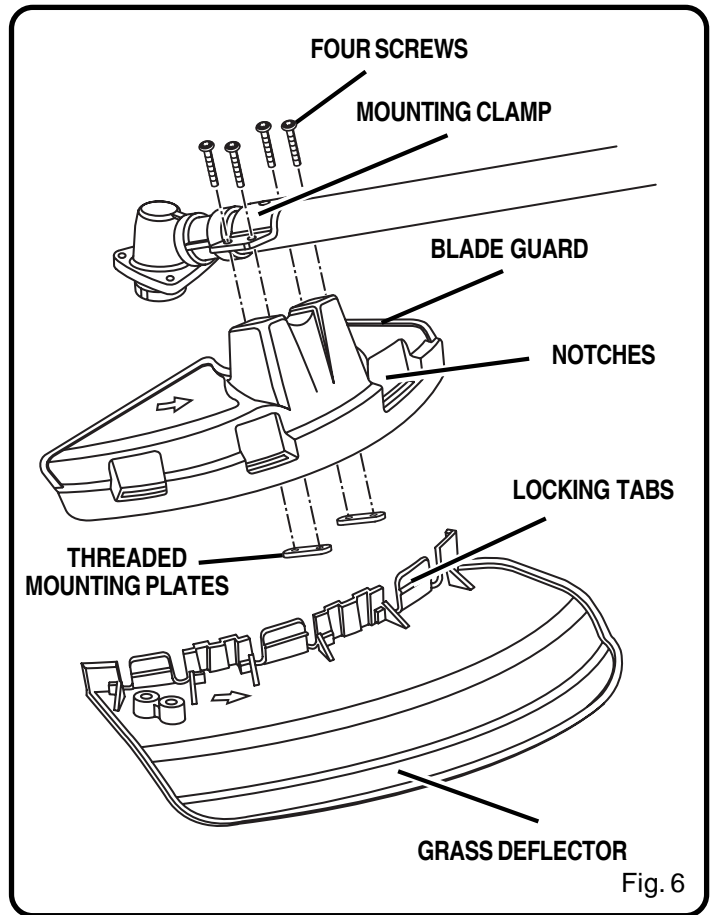

ASSEMBLY

INSTALLING THE BLADE

See Figure 8.

1. Place the upper flange washer over the gear shaft with the hollow side toward the blade guard.
2. Centre the blade on the upper flange, making sure the blade sits flat. Install the cupped washer with the raised centre away from the blade. Install the blade nut. The blade turns anticlockwise from the operator's position.
3. Place the holding pin through the slot in the upper flange washer and the hole in the gear head. Using the 13 mm (1/2 in) spanner supplied, turn the blade nut anticlockwise.
4. Tighten nut securely.

CONVERTING FROM BRUSHCUTTER TO TRIMMER

REMOVING THE BLADE

See Figure 8.

1. Place the holding pin through the slot in the upper flange washer and the gear head. Turn the blade nut clockwise to remove.
2. Remove the cupped washer and the blade.
3. Remove the upper flange washer from the gear shaft and retain for the string head installation.
4. Attach the grass deflector to the blade guard by placing the three locking tabs into the three notches.
5. Snap the blade guard and grass deflector together to lock into place.

NOTE: Store the brushcutter parts together for later use.

INSTALLING THE STRING HEAD

See Figure 7.

1. Install the upper flange washer onto the gear shaft with the hollow side toward the gear head.
2. Place the holding pin through the slot in the upper flange washer and the hole in the gear head. Using the 16 mm (5/8 in) spanner supplied, turn the drive connector anticlockwise to install. Tighten securely.
3. Place the string head on the drive connector.
4. Place the holding pin through the slot in the upper flange washer and the hole in the gear head. Install the spool retainer and turn anticlockwise to tighten securely.

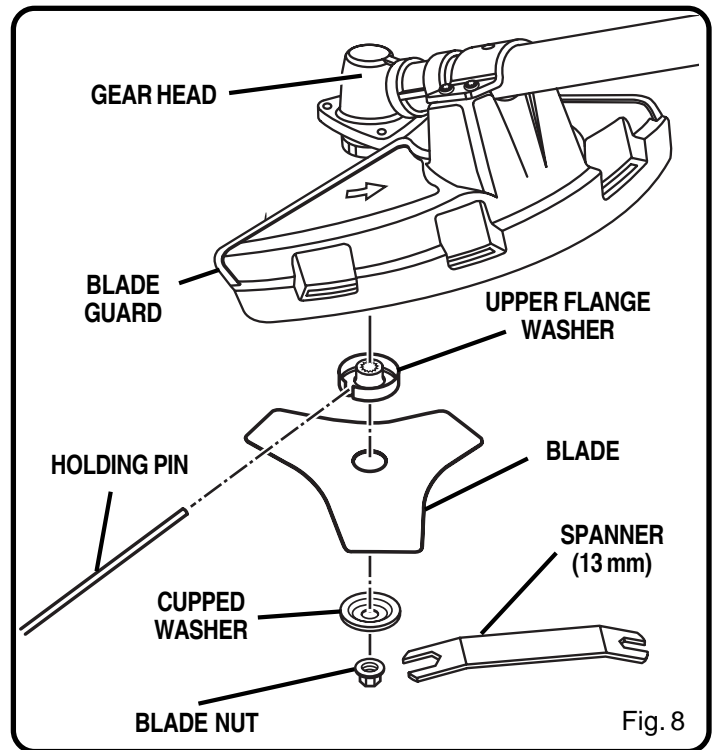

Fig. 8

OPERATION

FUEL AND REFUELLING

HANDLING THE FUEL SAFELY

- Always handle fuel with care. It is highly flammable.
- Always refuel outdoors where there are no sparks and flames. Do not inhale fuel vapour.
- Do not let petrol or oil come in contact with your skin.
- Keep petrol and oil away from the eyes. If petrol or oil comes in contact with the eyes, wash them immediately with clean water. If irritation is still present, see a doctor immediately.
- Clean up spilled fuel immediately.

MIXING THE FUEL

- This product is powered by a 2-cycle engine and requires pre-mixing petrol and 2-cycle oil. Pre-mix unleaded petrol and 2-cycle engine oil in a clean container approved for petrol.
- This engine is certified to operate on unleaded petrol intended for motor vehicle use with an octane rating of 87 ([R + M] / 2) or higher.
- Do not use any type of pre-mixed petrol/oil from fuel service stations. This includes the pre-mixed petrol/oil intended for use in mopeds, motorcycles etc.
- Use high a quality 2-cycle self-mixing oil for air cooled engines. Do not use motor vehicle oil or 2-cycle outboard oil.
- Mix 2% oil into the petrol. This is a 50:1 ratio.
- Mix the fuel thoroughly and also each time before refuelling.
- Mix in small quantities. Do not mix quantities larger than usable in a 30 day period. A 2-cycle oil containing a fuel stabiliser is recommended.

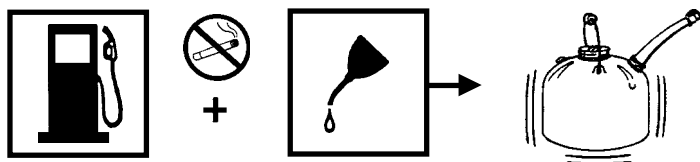

FILLING THE TANK



1. Clean surface round fuel cap to prevent contamination.
2. Loosen fuel cap slowly to release pressure and to keep fuel from escaping around the cap.
3. Carefully pour fuel mixture into the tank. Avoid spillage.

4. Prior to replacing the fuel cap, clean and inspect the gasket.
5. Immediately replace fuel cap and hand tighten. Wipe up any fuel spillage. Move 9 m (30 ft) away from refuelling site before starting engine.

NOTE: It is normal for smoke to be emitted from a new engine during and after first use.

WARNING:

Always shut off engine before refuelling. Never add fuel to a machine with a running or hot engine. Move at least 9 m (30 ft) from refuelling site before starting engine. Do not smoke!

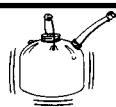
	+		=	
1 Litre	+	20 ml	=	} 50:1
2 Litres	+	40 ml	=	
3 Litres	+	60 ml	=	
4 Litres	+	80 ml	=	
5 Litres	+	100 ml	=	

OPERATING THE TRIMMER

Hold the trimmer/brushcutter with the right hand on the rear handle and the left hand on the front handle. Keep a firm grip with both hands while in operation. Trimmer should be held at a comfortable position with the trigger handle about hip height. See *Figure 9*.

Always operate trimmer at full throttle. Cut tall grass from the top down. This will prevent grass from wrapping round the shaft housing and string head, which may cause damage from overheating. If grass becomes wrapped round the string head, stop the engine, disconnect the sparking plug wire, and remove the grass. Prolonged cutting at partial throttle will result in oil dripping from the silencer.

OPERATION



Fig. 9

ADVANCING THE STRING

ADVANCING STRING USING THE EZ LINE™ TAP ADVANCE SYSTEM

String advance is controlled by tapping string head on grass while running engine at full throttle.

1. Run engine at full throttle.
2. Tap string head on ground to advance string. String advances each time the head is tapped.
3. Several taps may be required until string strikes the cut off blade.
4. Resume trimming.

NOTE: If the string is worn too short you may not be able to advance the string by tapping it on the ground. If so, STOP THE ENGINE, and manually advance the string.

ADVANCING THE STRING MANUALLY

Push the spool retainer down while pulling on string(s) to manually advance the string.

CUTTING TIPS

See Figure 10.

- Keep the trimmer tilted toward the area being cut; this is the best cutting area.
- Do not cut in dangerous cutting area.
- Use the tip of string to do the cutting; do not force string head into uncut grass.
- Wire and picket fences cause extra string wear, even breakage. Stone and brick walls, kerbs and wood may wear string rapidly.
- Avoid trees and shrubs. Tree bark, wood mouldings, cladding and fence posts can easily be damaged by the string.

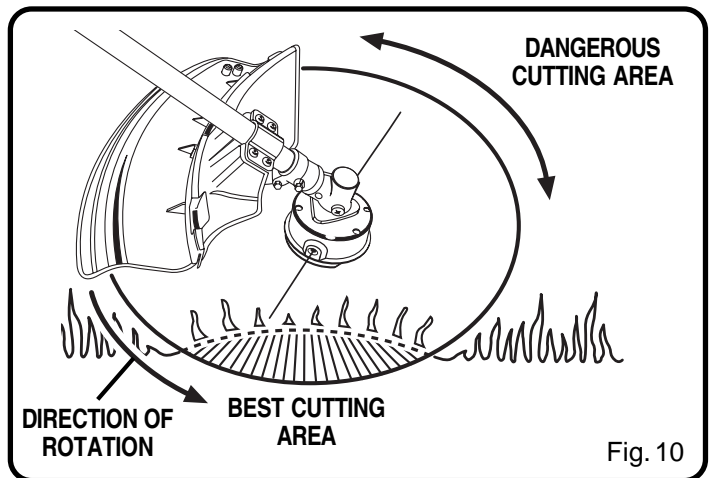

Fig. 10

GRASS DEFLECTOR LINE TRIMMING CUT-OFF BLADE

See Figure 11.

This trimmer is equipped with a line trimming cut-off blade on the grass deflector. For best cutting, advance string until it is trimmed to length by the cut-off blade. Advance string whenever you hear the engine running faster than normal. This will maintain best performance and keep string long enough to advance properly.

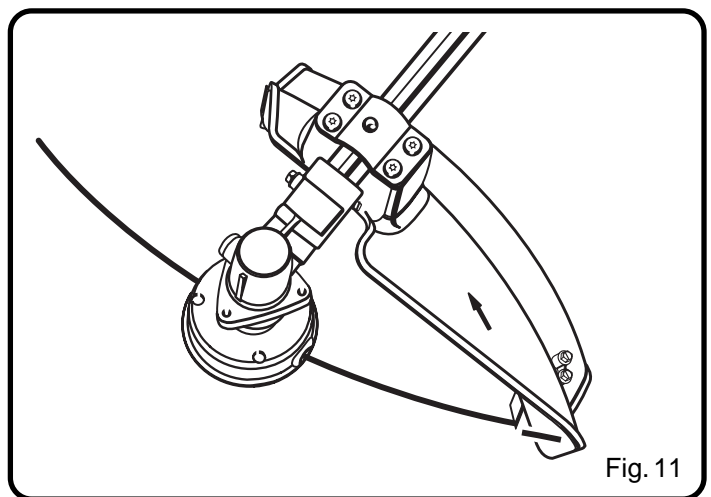

Fig. 11

OPERATION

OPERATING THE BRUSHCUTTER

Hold the brushcutter with the right hand on the trigger handle and the left hand on the left handle. Keep a firm grip with both hands while in operation. Brushcutter should be held at a comfortable position with the trigger handle about hip height. Maintain your grip and balance on both feet. Position yourself so that you will not be drawn off balance by the kick-back reaction of the cutting blade.

Adjust the shoulder strap to position the brushcutter at a comfortable operating position and to assure that the shoulder strap will reduce the risk of operator contact with the blade. See Figure 12.



Fig. 12

Exercise extreme caution when using the blade with this unit. Blade thrust is the reaction which may occur when the spinning blade contacts anything it cannot cut. This contact may cause the blade to stop for an instant, and suddenly “thrust” the unit away from the object that was hit. This reaction can be violent enough to cause the operator to lose control of the unit. Blade thrust can occur without warning if the blade snags, stalls or binds. This is more likely to occur in areas where it is difficult to see the material being cut. For cutting ease and safety, approach the weeds being cut from the right to the left. In the event that an unexpected object or woody stock is encountered, this could minimise the blade thrust reaction. See Figure 13.

APPROACH THE WEEDS BEING CUT FROM THE RIGHT. THE WEEDS WILL BE CUT AGAINST THE LEFT SIDE OF THE BLADE GUARD.

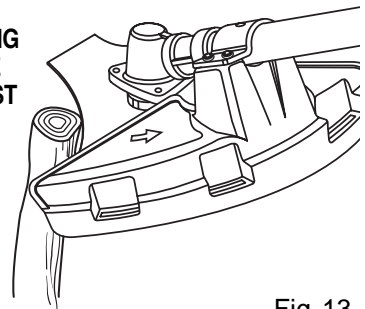

Fig. 13

TRI-ARC BLADE

The TRI-ARC blade is suited only for pulpy weeds and vines. When the blade becomes dull, it can be turned over to extend the life of the blade. Do not sharpen the TRI-ARC blade.

Use only TRI-ARC blade, part number 984227001, available at your local retailer.

CUTTING TECHNIQUE - BLADE

⚠ WARNING:

Extreme care must be taken when using blades to insure safe operation. Read the safety information for safe operation using the blade, refer to “Specific Safety Rules for Brushcutter and Blade Use” earlier in this manual.

- Always hold brushcutter with both hands when operating. Use a firm grip on both handles.
- Maintain your grip and balance on both feet. Position yourself so that you will not be drawn off balance by the kick-back reaction of the cutting blade.
- Inspect and clear the area of any hidden objects such as glass, stones, concrete, fencing, wire, wood, metal etc.
- Never use blades near footpaths, fencing, posts, buildings or other immovable objects.
- Never use a blade after hitting a hard object without first inspecting it for damage. Do not use if any damage is detected.
- Scythe, the broad sweeping of the unit back and forth from side to side, with TRI-ARC blade only.

OPERATION

STARTING AND STOPPING

See Figures 14 and 15.

NOTE: The unit is equipped with an automatic choke feature. The starting instructions for this feature are different from units with a manual choke. Be sure to read and follow the starting instructions below.

⚠ WARNING:

Never start or run the engine inside a closed or poorly ventilated area; breathing exhaust fumes can kill.

TO START A COLD ENGINE:

1. Lay trimmer on a flat, bare surface. Move switch to "I" (RUN) position.
NOTE: Unit is equipped with a positive on-off switch: make sure switch is in the "I" (RUN) position before starting the unit.
2. Push primer bulb **8 to 10 times**.
3. Set choke lever to choke position (I-|).
4. Depress interlock, squeeze trigger and pull starter rope until engine tries to run. (No more than 6 pulls.)
5. Set choke lever to half choke position (I-|).
6. Hold trigger and pull starter rope until engine runs.
7. Run engine 30 to 45 seconds at full throttle (with trigger depressed fully) on half choke position (I-|) to warm up. Move choke lever to run position (I-|).

TO START A WARM ENGINE:

1. Move choke lever to run position (I-|).
2. Hold trigger and pull starter rope until engine runs.

TO STOP THE ENGINE:

To stop the engine, depress the switch to "O" position.

NOTE: Be sure to return the stop switch to the "I" (RUN) position before trying to start unit.

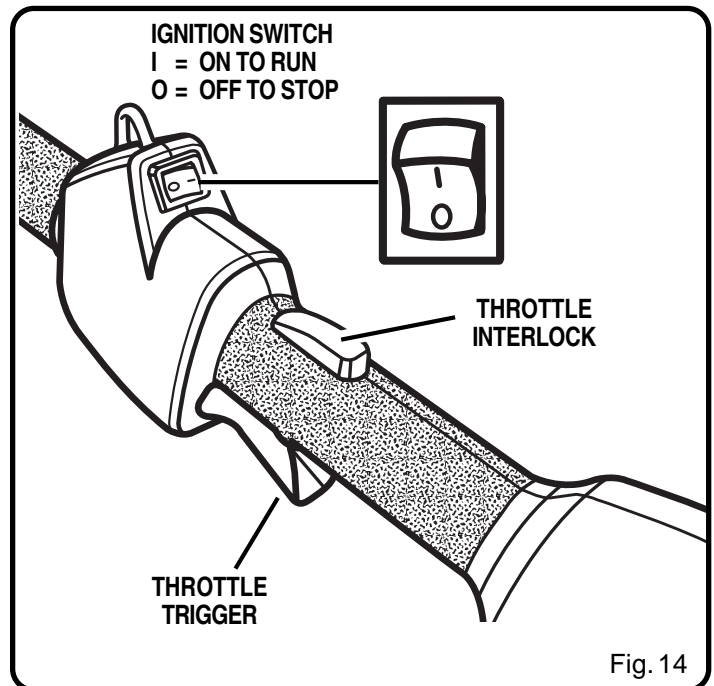

Fig. 14

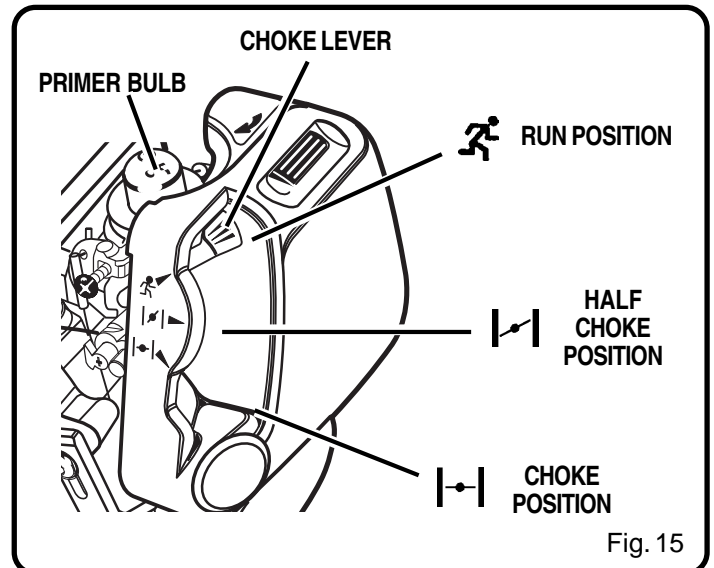

Fig. 15

MAINTENANCE

⚠ WARNING:

Use only original manufacturer's replacement parts, accessories and attachments. Failure to do so can cause possible injury, poor performance and may void your warranty.

- You may make adjustments and repairs described here. For other repairs, have the trimmer serviced by an authorised service dealer.
- Consequences of improper maintenance may include excess carbon deposits resulting in loss of performance and discharge of black oily residue dripping from the silencer.
- Make sure all guards, straps, deflectors and handles are properly and securely attached to avoid the risk of personal injury.

SPOOL REPLACEMENT

EZ LINE™ TAP ADVANCE SYSTEM

NEW PRE-WOUND SPOOL

See Figures 16 and 17.

If replacing string only, refer to "String Replacement" later in this manual.

Use only 2.4 mm (0.095 in) diameter monofilament string. Use the manufacturer's replacement string for best performance.

1. Stop the engine and disconnect the sparking plug wire. Hold the string head and unscrew the spool retainer. Turn clockwise.
2. Remove the empty spool from the string head. Keep the spring attached to the spool.
3. To install the new spool, make sure the two strings are captured in the slots opposite each other on the new spool. Make sure the ends of each string are extended approximately 152 mm (6 in) beyond each slot.
4. Thread the strings into the eyelets in the string head. Carefully push the spool into the string head (gently pull the strings to the outside if necessary). When the spool is positioned in the string head, grasp the strings and pull sharply to release them from the slots in the spool.
5. Push down and turn the spool anticlockwise until it no longer turns. Hold the spool down and rotate clockwise a small amount. Release the spool. The spool should be locked down in the string head. If not, hold down and rotate until locked.

6. Make sure the string head and the spool retainer are installed on the shaft by turning the retainer anticlockwise to tighten.
7. Pull the strings again to rotate the spool into cutting position. Push the spool retainer down while pulling on string(s) to manually advance the string and to check for proper assembly of the string head.

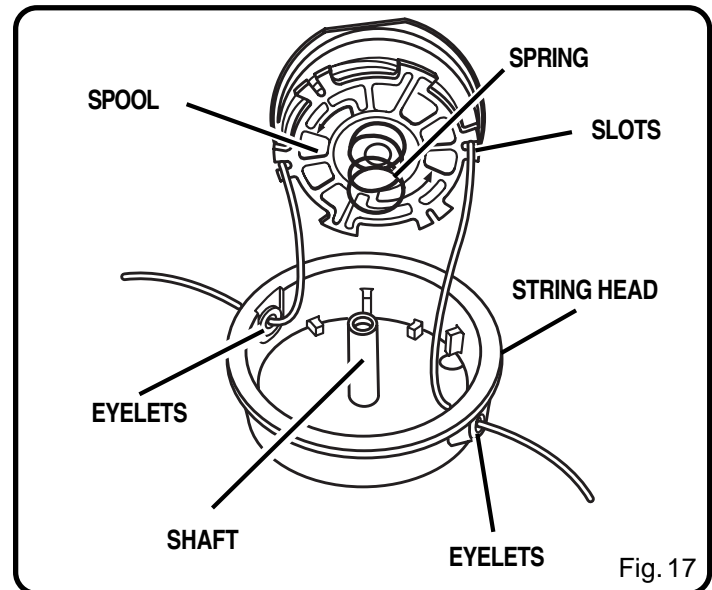
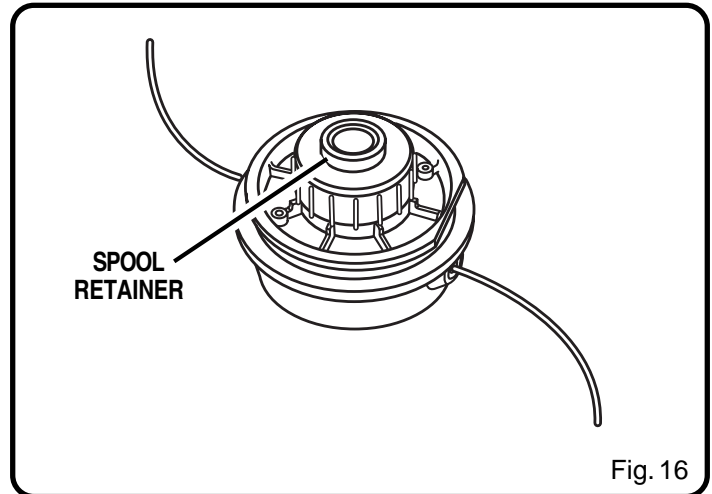

MAINTENANCE

STRING REPLACEMENT

See Figures 18, 19, 20, and 21.

1. Stop the engine, disconnect the sparking plug wire. Hold the string head and unscrew the spool retainer. Turn clockwise.
2. Remove the spool from the string head. **NOTE:** Keep the spring attached to the spool. Remove any old string remaining on the spool.
3. Cut two pieces of string, each being approximately 2.7 m (9 ft) long.
4. Insert the first string into the anchor hole in the upper part of the spool. Wind the first string around the upper part of the spool anticlockwise, as shown by the arrows on the spool. Place string in the slot on upper spool flange, leaving about 152 mm (6 in) extended beyond the slot. Do not overfill. After winding the string, there should be at least 6 mm (1/4 in) between the wound string and the outside edge of the spool.
5. Repeat above step with second string, using the bottom part of spool. Do not overfill.
6. Replace the spool and the spool retainer. Refer to "Spool Replacement" earlier in this manual.

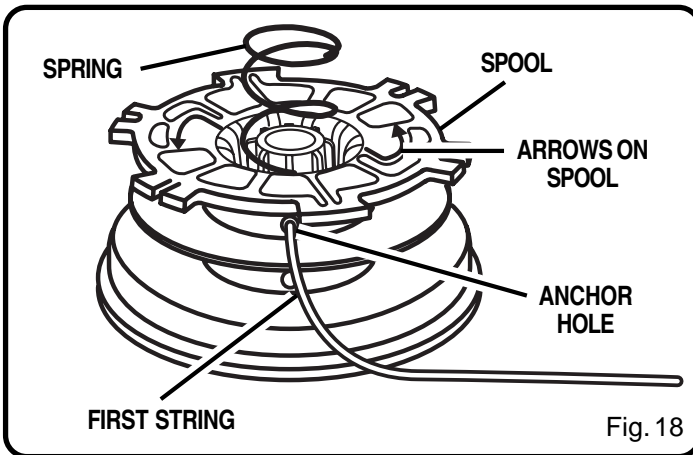

Fig. 18

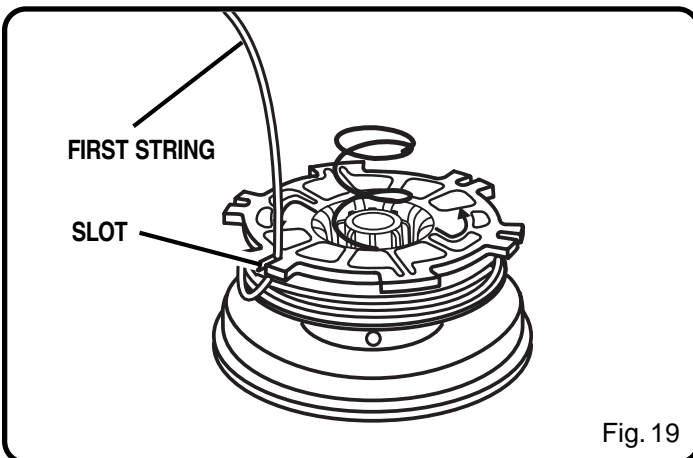

Fig. 19

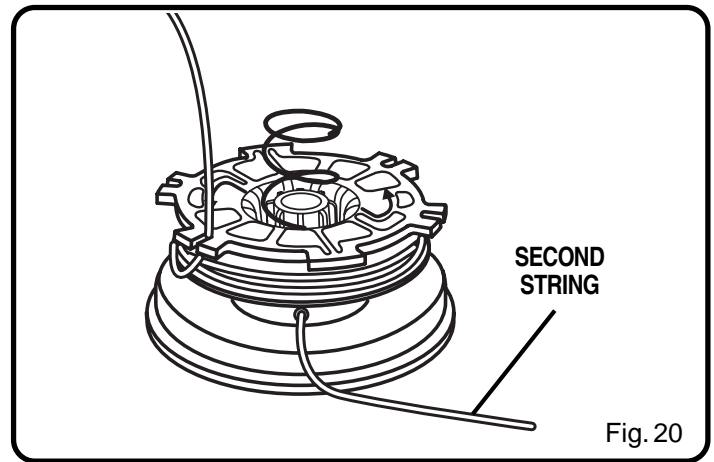

Fig. 20

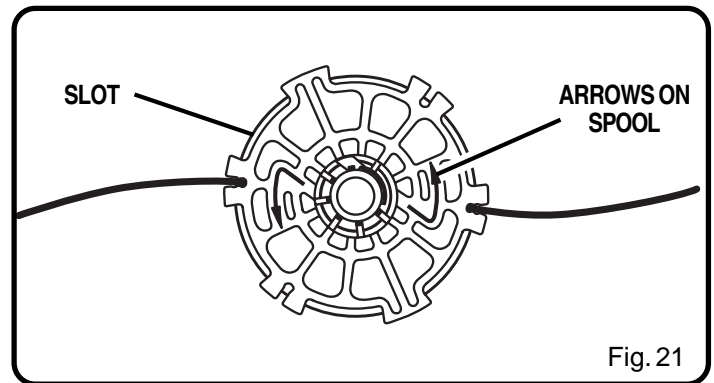

Fig. 21

BLADE PROTECTOR

See Figures 22.

Always place the blade protector on the blade when the unit is not in use. The blade protector has clips round the edges to snap over the blade and keep it in place. Wear gloves and be cautious when handling the blade.

NOTE: Always remove the blade protector before using the unit. If not removed, the blade protector could become a thrown object as the blade begins to turn.

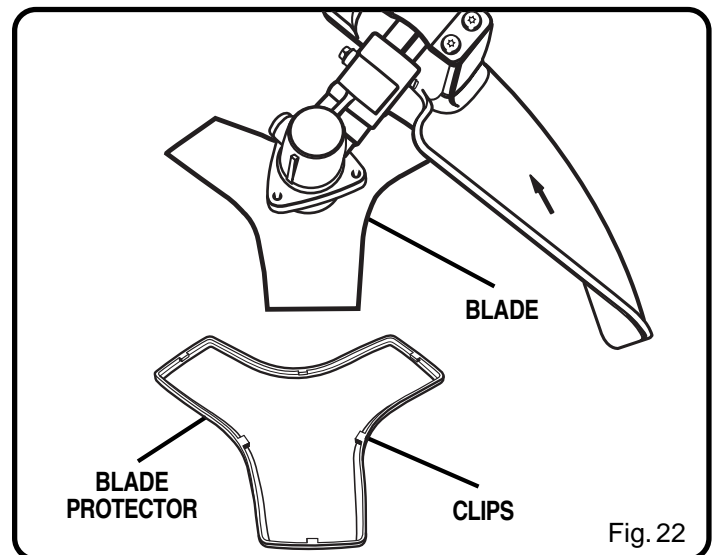

Fig. 22

MAINTENANCE

CLEANING THE EXHAUST PORT AND SILENCER

Depending on the type of fuel used, the type and amount of oil used, and/or your operating conditions, the exhaust port and silencer may become blocked with carbon deposits. If you notice a power loss with your petrol-powered tool, a qualified service technician will need to remove these deposits to restore performance.

SPARK ARRESTER

The spark arrester must be cleaned or replaced every 25 hours or yearly to ensure proper performance of your product. Spark arresters may be in different locations depending on the model purchased. Please contact your nearest service dealer for the location of the spark arrester for your model.

Cleaning Instructions:

- Remove the spark arrester from the silencer.
- If your spark arrester is made of fibreglass, discard and replace.
- If your spark arrester is made of metal, follow these cleaning instructions:
 1. Spray the spark arrester with a quality carbon cleaner.
 2. Gently clean using a wire brush.
 3. Install the new or cleaned spark arrester and reassemble completely before use.

REPLACING AND CLEANING AIR FILTER

See Figures 23 and 24.

For proper performance and long life, keep air filter clean.

1. Remove the air filter cover by pushing down on the latch with your thumb while gently pulling on the cover.
2. Remove the filter and clean it in warm soapy water. Rinse and let dry completely. For best performance, replace annually.
3. Reinstall the filter.
4. Replace the air filter cover by inserting the tabs on the bottom of the cover into the slots on the air filter base; push the cover up until it latches securely in place.

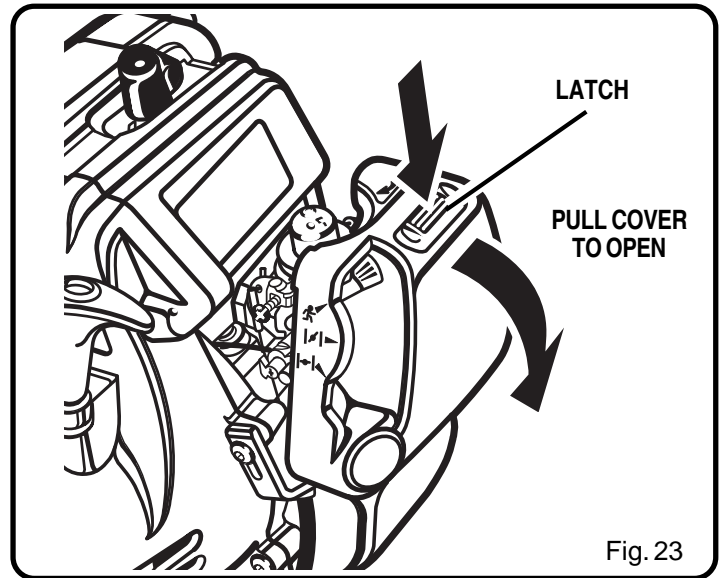

Fig. 23

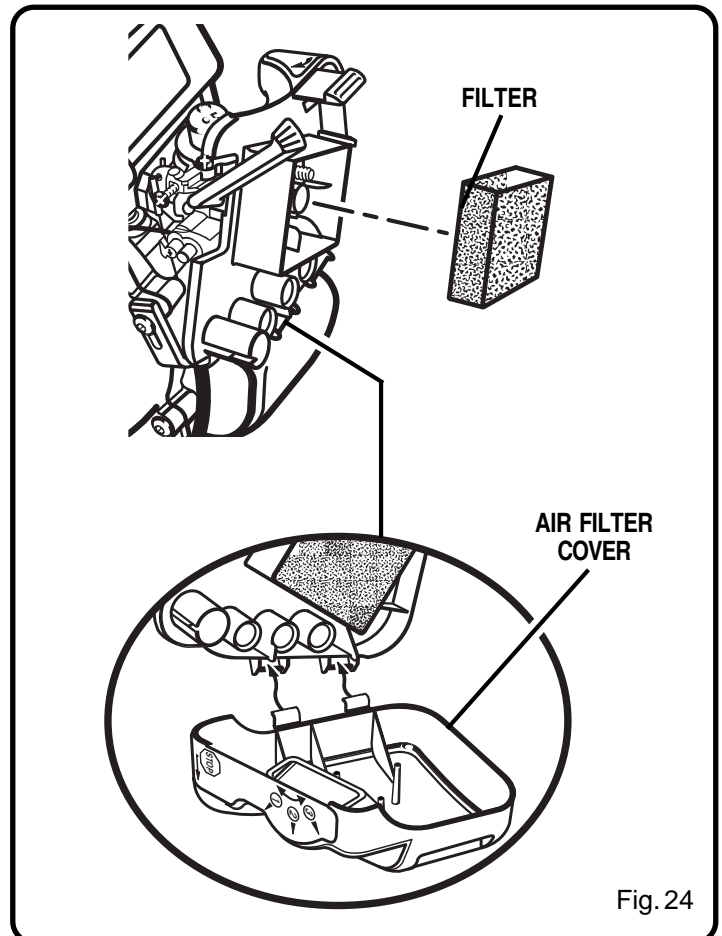

Fig. 24

MAINTENANCE

FUEL CAP

 **WARNING:**

A leaking fuel cap is a fire hazard and must be replaced immediately.

The fuel cap contains a non-serviceable filter and a check valve. A clogged fuel filter will cause poor engine performance. If performance improves when the fuel cap is loosened, the check valve may be faulty or the filter clogged. Replace fuel cap if required.

SPARKING PLUG

This engine uses a Champion RCJ-6Y with 0.63 mm (0.025 in) electrode gap. Use an exact replacement and replace annually.

STORAGE (1 MONTH OR LONGER)

1. Drain all fuel from tank into a container approved for petrol. Run engine until it stops.
2. Clean all foreign material from the trimmer. Store it in a well-ventilated place that is inaccessible to children. Keep away from corrosive agents such as garden chemicals and de-icing salts.
3. Abide by all ISO and local regulations for the safe storage and handling of petrol. Excess fuel should be used up in other 2-cycle engine-powered equipment.

TROUBLESHOOTING

IF THESE SOLUTIONS DO NOT SOLVE THE PROBLEM, CONTACT YOUR AUTHORISED SERVICE DEALER.

PROBLEM	POSSIBLE CAUSE	SOLUTION
Engine will not start:	<ol style="list-style-type: none"> 1. No spark. 2. No fuel. 3. Flooded engine. 4. Starter rope pulls harder now than when new. 	<ol style="list-style-type: none"> 1. Check spark. Remove sparking plug. Reattach the sparking plug cap and lay sparking plug on metal cylinder. Pull the starter rope and watch for spark at sparking plug tip. If there is no spark, repeat test with a new sparking plug. 2. Push primer bulb until bulb is full of fuel. If bulb does not fill, primary fuel delivery system is blocked. Contact a service dealer. If primer bulb fills, engine may be flooded (see next item). 3. Remove sparking plug, turn trimmer so sparking plug hole is aimed at the ground. Move choke lever to "RUN" and pull starter cord 10 to 15 times. This will clear excess fuel from engine. Clean and reinstall sparking plug. Pull starter three times with choke lever at "RUN". If engine does not start, move choke lever to "CHOKE" and repeat normal starting procedure. If engine still fails to start, repeat procedure with a new sparking plug. 4. Contact a service dealer.
Engine starts but will not accelerate:	Carburettor requires adjustment.	Turn "H" needle anticlockwise 1/16 turn. If "L" low needle cannot be turned anticlockwise; do not force plastic limiter caps. Contact a service dealer. <i>See Figure 25.</i>
Engine starts but will only run at high speed at half choke:	Carburettor requires adjustment.	Turn "H" needle anticlockwise 1/16 turn. If "H" high needle cannot be turned anticlockwise; do not force plastic limiter caps. Contact a service dealer. <i>See Figure 25.</i>
Engine does not reach full speed and emits excessive smoke:	<ol style="list-style-type: none"> 1. Check oil fuel mixture. 2. Air filter dirty. 3. Carburettor requires adjustment. 	<ol style="list-style-type: none"> 1. Use fresh fuel and the correct 2-cycle oil mix. 2. Clean the air filter. Refer to "Replacing and Cleaning the Air Filter" earlier in this manual. 3. Turn "H" needle clockwise 1/16 - 1/8 turn. <i>See Figure 25.</i>
Engine starts, runs, and accelerates but will not idle:	Carburettor requires adjustment.	Turn idle speed screw clockwise to increase idle speed.
Blade continues to rotate at idle speed:	Carburettor requires adjustment.	Turn idle speed screw anticlockwise to reduce idle speed. <i>See Figure 25.</i> If after adjustment, blade continues to rotate, return to an authorised service dealer for repair.

TROUBLESHOOTING

IF THESE SOLUTIONS DO NOT SOLVE THE PROBLEM, CONTACT YOUR AUTHORISED SERVICE DEALER.

PROBLEM	POSSIBLE CAUSE	SOLUTION
String will not advance:	<ol style="list-style-type: none"> 1. String welded to itself. 2. Not enough string on spool. 3. String worn too short. 4. String tangled on spool. 5. Engine speed too slow. 	<ol style="list-style-type: none"> 1. Lubricate with silicone spray. 2. Install more string. Refer to "String Replacement" earlier in this manual. 3. Pull strings while alternately pressing down on and releasing spool retainer. 4. Remove string from spool and rewind. Refer to "String Replacement" earlier in this manual. 5. Advance string at full throttle.
Grass wraps round shaft housing and string head:	<ol style="list-style-type: none"> 1. Cutting tall grass at ground level. 2. Operating trimmer at part throttle. 	<ol style="list-style-type: none"> 1. Cut tall grass from the top down. 2. Operate trimmer at full throttle.
Spool retainer hard to turn:	Screw threads dirty or damaged.	Clean threads and lubricate with grease - if no improvement, replace spool retainer.
Oil drips from silencer:	<ol style="list-style-type: none"> 1. Operating trimmer at part throttle 2. Check oil/fuel mixture. 3. Air filter dirty. 4. Carburettor requires adjustment. 	<ol style="list-style-type: none"> 1. Operate trimmer at full throttle. 2. Use fresh fuel and the correct 2-cycle oil mix. 3. Clean air filter. Refer to "Replacing and Cleaning the Air Filter" earlier in this manual. 4. Turn "H" needle clockwise 1/16 - 1/8 turn. <i>See Figure 25.</i>

NOTE: The carburettor adjustment needle(s) are equipped with plastic cap(s) which prevent anticlockwise rotation from the original factory adjustment. If your unit exhibits specific performance problem(s) where the Troubleshooting Section recommends an anticlockwise needle adjustment and no adjustments have been made since original purchase, the unit should be taken to a factory-authorized service dealer for repair. In most cases, the needed adjustment is a simple task for the factory-trained service representative.

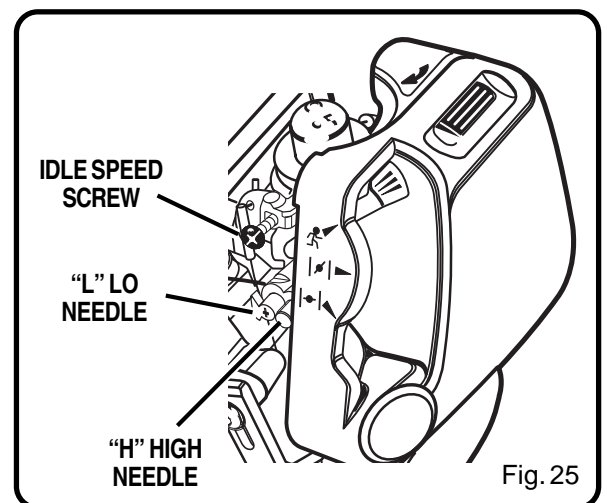

WARRANTY

GUARANTEE – STATEMENT

(RTSA / RTUK / RTG)

All Homelite products are guaranteed from defects in material and workmanship for a period of twenty-four (24) months, effective and evidenced from date of original invoice or delivery note.

Defects caused by normal wear and tear, unauthorised/improper maintenance/handling or overload are excluded from this guarantee as are accessories such as battery packs, bulbs, blades and bits etc.

In the event of malfunction within the guarantee period, please return the assembled product with proof of purchase to your dealer or nearest Homelite Service Centre.

Your statutory rights in respect of defective products remain unaffected by the warranty.

Ryobi Technologies GmbH, Itterpark 7, D-40724 Hilden, Germany

Ryobi Technologies, Customer Services, Anvil House, Tuns Lane, Henley-on-Thames, RG9 1SA, UK

Homelite / R.T.S.A BP 50012 - 95945 Roissy CDG Cedex – FRANCE

Ryobi Technologies Australia PTY Limited, 359-361 Horsley Road, Milperra, NSW 2214 Australia

SAFETY DIRECTIVE

SOUND POWER/PRESSURE AND HANDLE VIBRATION CHART FOR TRIMMERS / BRUSHCUTTERS

Information on Noise Emission per European Machine Safety Directive 98/37/EC.

The individual equipment listed was operated in a manner consistent with normal working conditions.

The A-weighted sound pressure level (LpA) at the operator's ear and the A-weighted sound power level (LWA) were both measured in accordance

with Directive 79/113/EEC. Hearing protection is recommended where levels exceed 85 dBA.

Handle vibration was measured in accordance to ISO 7916. Read the safety precautions section of the manual.

MODEL	MODEL NO.	SOUND PRESSURE LpA (dBA)	SOUND POWER LwA (dBpA)	VIBRATION m/s ²
F3040	UT70131	100	112	10.5

EC DECLARATION OF CONFORMITY

According to machinery directive 98/37/EC and EMC directive 89/336/EEC - We,

Homelite Consumer Products Inc., 1428 Pearman Dairy Road, Anderson, SC 29625, USA

declare in sole responsibility that the product: F3040 (UT70131) - to which this certificate applies, conforms to the basic health and safety requirements of the Machinery Directive 98/37/EC and other relevant directives, such as EMC Directive 89/336/EEC and Outdoor Directive 2000/14/EC.

To effect correct application of the health and safety requirements stated in the EEC directives, the following European and/or national standards and/or technical specifications were consulted: EN ISO 14982:1998, ISO 7916 & 7917, EN ISO 11806:1997, ISO 7918-1995, ISO 8380-1993, ISO 8893-1989, ISO 10884-1995. EN 292-1:1991, EN 292-2:1991, EN 292-2:1991/A1:1995, EN 563-1994, EN 27917-1991, ISO 7112-1982, ISO 7113-1991

Wayne Hill
Director, Environmental Compliance

Homelite Consumer Products, Inc.
1428 Pearman Dairy Road
Anderson, SC 29625, USA



December 22, 2002

Homelite®

OPERATOR'S MANUAL

Trimmer / Brushcutter

F3040

UT70131

Ryobi Technologies GmbH

Itterpark 7
D-40724 Hilden
Germany
Tel.: +49 (0)2103 / 29 58 0
Fax : +49 (0)2103 / 29 58 29
info@ryobi-rtg.de

Ryobi Technologies

Customer Services
Anvil House
Tuns Lane
Henley-on-Thames
RG9 1SA
UK

Homelite / R.T.S.A

BP 50012 - 95945 Roissy CDG Cedex – FRANCE

Ryobi Technologies Australia PTY Limited

359-361 Horsley Road, Milperra, NSW 2214 Australia