



FPWB-B434DRKZ B01-02

IEEE 802.11 b/g/n 1x1 AIOT Module

Product Specification 1.4

Approved:	Approved:	Prepared by:
<hr style="width: 80%; margin-left: 0;"/>	<hr style="width: 80%; margin-left: 0;"/>	<hr style="width: 80%; margin-left: 0;"/>
Zeke Wu Manager	Matt Lin Supervisor	Ben Ho Engineer

Revision History

Date	Number	Approver	Comments
Dec. 18, 2016	1.0	Ben Ho	Initial Draft
Jan. 04, 2017	1.1	Ben Ho	Adding information of Current consumption and Sensitivity
Jan. 25, 2017	1.2	Ben Ho	Adding information of Current consumption and Power consumption
Mar. 31, 2017	1.3	Ben Ho	Adding PCB layout, Placement, PCB specification, schematic, BOM, RF input and output characteristic Connector specification and reliability test item
Oct. 26, 2017	1.4	Cathy Kuo	Added FCC & IC Statement

RESTRICTED AND CONFIDENTIAL INFORMATION STATEMENT

All information contained in this document is the exclusive property of Foxconn Technology Inc. and its development partners. Any reproduction or disclosure of all or part of this document without the expressed written consent of Foxconn Technology Inc. is strictly prohibited.

TABLE OF CONTENTS

Revision History	2
Table of Contents	4
Chapter 1. Module Overview	5
1-1 Key Characteristic	5
1-2 Pin Definition	6
1-3 PCB Specification.....	7
Chapter 2. Electrical and RF Specifcaiton	8
2-1 Recommended Operation Rating	8
2-2 Digital IO Pin DC Characteristic.....	8
2-3 Analog Performance	8
2-4 Power Consumption	9
2-5 RF input and Output Characteristic	9
2-6 WiFi RF Specification – TX.....	9
2-7 WiFi RF Specification – RX	10
2-8 Antenna Specification Requirements	11
Chapter 3. MECHANICAL SPECIFICATION	12
3-1 Module Assembly Dimension	12
Chapter 4. Additional Information	13
4-1 Module Photo	13
4-2 Environment Specifications	13

CHAPTER 1. MODULE OVERVIEW

The Foxconn B01-02 is a low profile, low power and high performance AIOT module. It is mainly consisted of Wireless IOT IC RTL8711AM, codec ALC5640 and 8MB flash for developing IOT application

RTL8711AM is a highly integrated single-chip low power 802.11b/g/n Wireless LAN (WLAN) network controller. It combines an ARM-Cortex M3 MCU, WLAN MAC, a 1T1R capable WLAN based, and RF in a single chip. It also provides a bunch of configure GPIOs which are configured as digital peripheral for different applications and control usage. ALC5640 is a high performance, low power, dual I²S interface audio codec. Asynchronous Sample Rate Converter (ASRC) provides independent and asynchronous connections to different processors, such as an application processor, baseband processor or wireless transceiver.

Alc5640 have stereo Class-D Speaker amplifiers provide 1.5W per channel into 8Ω or 2.5W per channel into 4Ω with a 5V supply, with excellent PSRR and low EMI.

1-1 Key Characteristic

- IEEE 802.11 a/b/g/n compatible WLAN
- 72.2Mnps receive and transmit PHY rate using 20MHz bandwidth
- 150Mnps receive and transmit PHY rate using 40MHz bandwidth
- 802.11i(WPA,WPA2). Open, shared key, and pair-wise key authentication services
- WiFi WPS support
- WiFi Direct support
- 1 set of I2C interface
- 1 set of log UART with standard baud rate support
- I2S with 8/16/24/32/48/96/44.1/88.2KHz sample rate
- Mono BTL(Bridge-Tied-Load) Class-D amplifier

1-2 Pin Definition



Figure 1 Pin Definitions (Module Top View)

Table 1 CN1 Terminal for home appliance Pin Definitions

Pin Number	Symbol Name	Type	Pin Description
1	VCC	POWER	DC 3.3V
2	VCC	POWER	DC 3.3V
3	UART0_RTS	I/O	UART RTS (RTL8711AM GPIOA_3)
4	UART0_CTS	I/O	UART CTS (RTL8711AM GPIOA_5)
5	UART0_RX	I/O	UART RX (RTL8711AM GPIOA_6)
6	UART0_TX	I/O	UART TX (RTL8711AM GPIOA_7)
7	CHIP_EN	I	Module enable control active : High(3.3V)
8	NC	NC	NC
9	I2C3_SCL	I/O	I2C Clock (RTL8711AM GPIOB_2)
10	I2C3_SDA	I/O	I2C data (RTL8711AM GPIOB_3)
11	GPIO	I/O	GPIO (RTL8711AM GPIOE_2)
12	GND	GND	Ground
13	SPKOUT_P	O	Speaker amplifier differential positive output
14	SPKOUT_N	O	Speaker amplifier differential negative output
15	GND	GND	Ground

Table 2 CN2 Service UART terminal Pin Definitions

Pin Number	Symbol Name	Type	Pin Description
1	VCC	POWER	DC 3.3V
2	DEBUG_UART_TX	I/O	Debug UART TX(RTL8711AM GPIOB_0)
3	DEBUG_UART_RX	I/O	Debug UART RX(RTL8711AM GPIOB_1)
4	GND	GND	Ground

1-3 PCB Specification

Board-maker: Foxconn 宏華精密電子(煙台)有限公司

Material of the board: FR4

Model number: 1P-1173X00-40SB

Board-thickness: 1.0mm (typ)

Product-height: 5.45mm (max)

Tolerance: 0.1mm

Flame class: UL94V-0

CHAPTER 2. ELECTRICAL AND RF SPECIFICATION

2-1 Recommended Operation Rating

Table 4 Operation Rating

Parameter	Condition	Min	Typ.	Max.	Unit
VCC	3.3V	3.0V	3.3V	3.6V	V
RF Interface	Zo		50		Ohm

2-2 Digital IO Pin DC Characteristic

Table 5 Typical IO DC Parameter (3.3V)

Symbol	Parameter	Conditions	Min.	Typ.	Max	Units
V _{IH}	Input-High Voltage	LVTTL	2	-	-	V
V _{IL}	Input-Low Voltage	LVTTL	-	-	0.8	V
V _{OH}	Output-High Voltage	LVTTL	2.4	-	-	V
V _{OL}	Output-Low Voltage	LVTTL	-	-	0.4	V
V _{T+}	Scmitt-trigger High Level		1.78	1.87	1.97	V
V _{T-}	Scmitt-trigger Low Level		1.36	1.45	1.56	V
I _{IL}	Input-Leakage Current	V _{IN} =3.3v or 0	-10	±1	10	μA

2-3 Analog Performance

Table 6 Analog Performance Characteristics

Parameter	Min.	Typ.	Max	Units
Full Scale Output Voltage Speaker Amplifiers Output (SPKVDD=5.0V with 4Ω Load,1% THD+N)	-	2.9	-	Vrms

2-4 Power Consumption

Table 8 Power Consumption

Description	Typical	Unit
IDLE (Disconnecting to AP)	106	mW
IDLE (Connecting to AP)	244	mW
Maxmimun B mode CCK11M(18dBm) with Speaker play Voice	983	mW
2G/1T- N mode HT 40MHz MCS 7 (13dBm)	779	mW
2G/1T- N mode HT 20MHz MCS 7 (13dBm)	795	mW
2G/1T- G mode OFDM54M (14dBm)	822	mW
2G/1T- B mode CCK11M (16dBm)	917	mW
2G/1R- N mode HT 40MHz MCS 7 (-60dBm)	231	mW
2G/1R- N mode HT 20MHz MCS 7 (-60dBm)	241	mW
2G/1R- G mode OFDM54M (-60dBm)	241	mW
2G/1R- B mode CCK11M (-60dBm)	241	mW

2-5 RF input and Output characteristic

- RF Input and Output characteristic (Ta=25°C)
- Transmitting and receiving frequency:1ch~13ch(center frequency 2412~2472MHz)
- Wireless system IEEE 802.11b/g/n

2-6 WiFi RF Specification – TX

Table 9 IEEE 802.11 b/g/n TX Output Power(Ave.)

Data Rate (Mbps)	Modulation	Tx Typical Power (dBm)	Data Rate (Mbps)	Modulation	Tx Typical Power (dBm)
1	DBPSK	16	HT20-MCS0	BPSK	13
2	DQPSK	16	HT20-MCS1	BPSK	13
5.5	CCK	16	HT20-MCS2	QPSK	13
11	CCK	16	HT20-MCS3	QPSK	13
6	OFDM	14	HT20-MCS4	16-QAM	13
9	OFDM	14	HT20-MCS5	16-QAM	13
12	OFDM	14	HT20-MCS6	64-QAM	13
18	OFDM	14	HT20-MCS7	64-QAM	13

24	OFDM	14			
36	OFDM	14			
48	OFDM	14			
54	OFDM	14			

2-7 WiFi RF Specification – RX

Table 10 IEEE 802.11 b/g/n RX Sensitivity

Data Rate (Mbps)	Modulation	Rx Sensitivity (dBm)		Data Rate (Mbps)	Modulation	Rx Sensitivity (dBm)	
		Max.	Typ.			Max.	Typ.
1	DBPSK	-83	-95	HT20-7.22	BPSK	-82	-92
2	DQPSK	-80	-94	HT20-14.44	QPSK	-79	-88.5
5.5	CCK	-79	-90	HT20-21.67	QPSK	-77	-86
11	CCK	-76	-87	HT20-28.89	16-QAM	-74	-83
6	OFDM	-85	-92.5	HT20-43.33	16-QAM	-70	-80
9	OFDM	-84	-91	HT20-57.78	64-QAM	-66	-75
12	OFDM	-82	-89.5	HT20-65	64-QAM	-65	-74
18	OFDM	-80	-87	HT20-72.22	64-QAM	-64	-73
24	OFDM	-77	-84	HT40-15	BPSK	-79	-87.5
36	OFDM	-73	-81	HT40-30	QPSK	-76	-85
48	OFDM	-69	-76	HT40-45	QPSK	-74	-83
54	OFDM	-68	-75	HT40-60	16-QAM	-71	-80
				HT40-90	16-QAM	-67	-77
				HT40-120	64-QAM	-63	-72
				HT40-135	64-QAM	-62	-70
				HT40-150	64-QAM	-61	-70

2-8 Antenna Specification Requirements

Nominal antenna port impedance specification is 50 ohms for the Foxconn B01 hardware.

For regulatory requirements, it is assumed that the antenna gain is:

Antenna gain for the 2.4GHz band : 2.0dBi



CHAPTER 3. MECHANICAL SPECIFICATION

3-1 Module Assembly Dimension

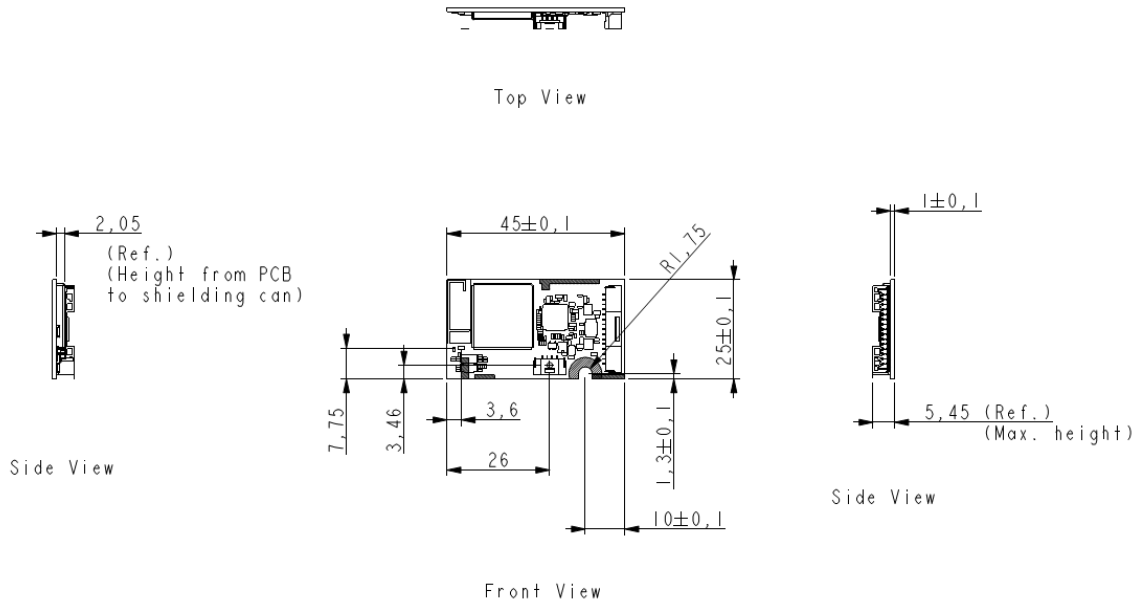

CHAPTER 4. ADDITIONAL INFORMATION

4-1 Module Photo



Figure 2 Top Side Photo

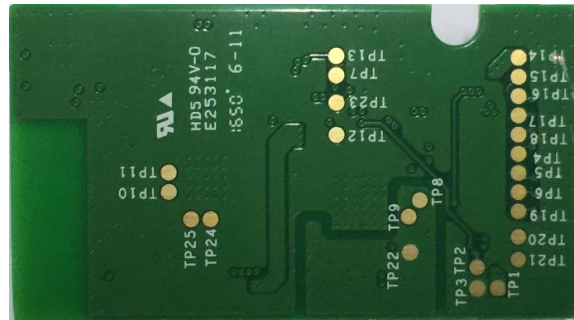

Figure3 Bottom Side Photo

4-2 Environment Specifications

- **Operating Conditions (preliminary)**

Operation Temperature : -10 ~ 80°C
 Relevant Humidity: 5 ~ 95% (non-condensing)

- **Storage Conditions (preliminary)**

Non-Operation Temperature : -20 ~ 85°C (Typ. 25°C)
 Relevant Humidity: 5 ~ 95% (non-condensing)

Federal Communication Commission Interference Statement

This device complies with Part 15 of the FCC Rules. Operation is subject to the following two conditions: (1) This device may not cause harmful interference, and (2) this device must accept any interference received, including interference that may cause undesired operation.

This equipment has been tested and found to comply with the limits for a Class B digital device, pursuant to Part 15 of the FCC Rules. These limits are designed to provide reasonable protection against harmful interference in a residential installation. This equipment generates, uses and can radiate radio frequency energy and, if not installed and used in accordance with the instructions, may cause harmful interference to radio communications. However, there is no guarantee that interference will not occur in a particular installation. If this equipment does cause harmful interference to radio or television reception, which can be determined by turning the equipment off and on, the user is encouraged to try to correct the interference by one of the following measures:

- Reorient or relocate the receiving antenna.
- Increase the separation between the equipment and receiver.
- Connect the equipment into an outlet on a circuit different from that to which the receiver is connected.
- Consult the dealer or an experienced radio/TV technician for help. FCC Caution: Any changes or modifications not expressly approved by the party responsible for compliance could void the user's authority to operate this equipment. This transmitter must not be co-located or operating in conjunction with any other antenna or transmitter.

Radiation Exposure Statement:

This equipment complies with FCC radiation exposure limits set forth for an uncontrolled environment. This equipment should be installed and operated with minimum distance 20cm between the radiator & your body.

This device is intended only for OEM integrators under the following conditions:

- 1) The antenna must be installed such that 20 cm is maintained between the antenna and users, and 2) The transmitter module may not be co-located with any other transmitter or antenna.

As long as 2 conditions above are met, further transmitter test will not be required. However, the OEM integrator is still responsible for testing their end-product for any additional compliance requirements required with this module installed

IMPORTANT NOTE: In the event that these conditions can not be met (for example certain laptop configurations or co-location with another transmitter), then the FCC authorization is no longer considered valid and the FCC ID can not be used on the final product. In these circumstances, the OEM integrator will be responsible for reevaluating the end product (including the transmitter) and obtaining a separate FCC authorization.

End Product Labeling

This transmitter module is authorized only for use in device where the antenna may be installed such that 20 cm may be maintained between the antenna and users. The final end product must be labeled in a visible area with the following: "Contains FCC ID: RX3-B01". The grantee's FCC ID can be used only when all FCC compliance requirements are met.

Manual Information To the End User

The OEM integrator has to be aware not to provide information to the end user regarding how to install or remove this RF module in the user's manual of the end product which integrates this module. The end user manual shall include all required regulatory information/warning as show in this manual.

Canada, Industry Canada (IC) Statement

This Class B digital apparatus complies with Canadian ICES-003.

This device complies with Industry Canada licence-exempt RSS standard(s). Operation is subject to the following two conditions:

- (1) this device may not cause interference, and
- (2) this device must accept any interference, including interference that may cause undesired operation of the device.

RF Radiation Exposure Statement:

This equipment complies with IC radiation exposure limits set forth for an uncontrolled environment. This equipment should be installed and operated with a minimum distance of 20 centimeters between the radiator and your body.

Required end product labeling:

Any device incorporating this module must include an external, visible, permanent marking or label which states: "Contains IC: 2878F-B01"

This radio transmitter (identify the device by certification number or model number if Category II) has been approved by Industry Canada to operate with the antenna types listed below with the maximum permissible gain indicated. Antenna types not included in this list, having a gain greater than the maximum gain indicated for that type, are strictly prohibited for use with this device.

Antenna Type: Printing Peak Gain: 2.0 dBi

Canada, Industrie Canada (IC) Déclaration

Cet appareil numérique de classe B est conforme à la norme NMB-003.

Le présent appareil est conforme aux CNR d'Industrie Canada applicables aux appareils radio exempts de licence. L'exploitation est autorisée aux deux conditions suivantes:

- (1) l'appareil ne doit pas produire de brouillage, et
- (2) l'utilisateur de l'appareil doit accepter tout brouillage radioélectrique subi, même si le brouillage est susceptible d'en compromettre le fonctionnement.

Déclaration d'exposition aux radiations:

Cet appareil est conforme aux limites d'exposition aux rayonnements définies pour un environnement non contrôlé. Cet équipement doit être installé et utilisé à une distance minimale de 20 centimètres entre le radiateur et votre corps.

Obligation d'étiquetage du produit final:

Tout dispositif intégrant ce module doit comporter un externe, visible, marquage permanent ou une étiquette qui dit: "Contient IC : 2878F-B01".

Cet émetteur radio (identifier le dispositif par numéro de certification ou le numéro de modèle , si la catégorie II) a été approuvé par Industrie Canada pour fonctionner avec les types d'antenne énumérés ci-dessous avec le gain maximal admissible indiqué . types d'antennes non inclus dans cette liste , ayant un gain supérieur au gain maximum indiqué pour ce type , sont strictement interdits pour une utilisation avec cet appareil.

Type d'antenne: Printing Pic Gain: 2.0 dBi