

**HONDA**  
**MARINE**

# Owner's Manual

BF8A

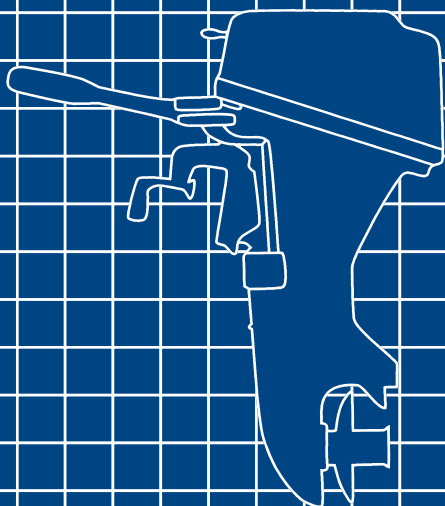



## **WARNING:**



The engine exhaust from this product contains chemicals known to the State of California to cause cancer, birth defects or other reproductive harm.

Keep this owner's manual handy, so you can refer to it at any time. This owner's manual is considered a permanent part of the outboard motor and should remain with the outboard motor if resold.

The information and specifications included in this publication were in effect at the time of approval for printing. Honda Motor Co., Ltd. reserves the right, however, to discontinue or change specifications or design at any time without notice and without incurring any obligation whatever. No part of this publication may be reproduced without written permission.

# INTRODUCTION

Congratulations on your selection of a Honda outboard motor. We are certain you will be pleased with your purchase of one of the finest outboard motors on the market.

We want to help you get the best results from your new outboard motor and to operate it safely. This manual contains the information on how to do that; please read it carefully.

As you read this manual, you will find information preceded by a **NOTICE** symbol. That information is intended to help you avoid damage to your outboard motor, other property, or the environment.

We suggest you read the warranty policy to fully understand its coverage and your responsibilities of ownership.

When your outboard motor needs scheduled maintenance, keep in mind that your Honda marine dealer is specially trained in servicing Honda outboard motors. Your Honda marine dealer is dedicated to your satisfaction and will be pleased to answer your questions and concerns.

Best Wishes,  
Honda Motor Co., Ltd.

# INTRODUCTION

---

## A FEW WORDS ABOUT SAFETY

Your safety and the safety of others are very important. And using this outboard motor safely is an important responsibility.

To help you make informed decisions about safety, we have provided operating procedures and other information on labels and in this manual. This information alerts you to potential hazards that could hurt you or others.

Of course, it is not practical or possible to warn you about all the hazards associated with operating or maintaining an outboard motor. You must use your own good judgment.

You will find important safety information in a variety of forms, including:

- **Safety Labels** — on the outboard motor.
- **Safety Messages** — preceded by a safety alert symbol  and one of three signal words, DANGER, WARNING, or CAUTION.

These signal words mean:

 **DANGER** You WILL be KILLED or SERIOUSLY HURT if you don't follow instructions.

 **WARNING** You CAN be KILLED or SERIOUSLY HURT if you don't follow instructions.

 **CAUTION** You CAN be HURT if you don't follow instructions.

- **Safety Headings** — such as *IMPORTANT SAFETY INFORMATION*.
- **Safety Section** — such as *OUTBOARD MOTOR SAFETY*.
- **Instructions** — how to use this outboard motor correctly and safely.

This entire book is filled with important safety information — please read it carefully.

# CONTENTS

|  |           |
|--|-----------|
| <b>OUTBOARD MOTOR SAFETY</b> .....           | <b>7</b>  |
| <b>IMPORTANT SAFETY INFORMATION</b> .....    | <b>7</b>  |
| Operator Responsibility .....                | 7         |
| Refuel With Care .....                       | 8         |
| Carbon Monoxide Hazard .....                 | 8         |
| <b>SAFETY LABEL LOCATIONS</b> .....          | <b>9</b>  |
| <br>   |           |
| <b>CONTROLS AND FEATURES</b> .....           | <b>10</b> |
| <b>COMPONENT AND CONTROL LOCATIONS</b> ..... | <b>10</b> |
| <b>CONTROLS</b> .....                        | <b>12</b> |
| Engine Stop Switch and Switch Clip .....     | 12        |
| Choke Knob .....                             | 12        |
| Throttle Grip .....                          | 13        |
| Throttle Friction Knob .....                 | 13        |
| Gearshift Lever .....                        | 14        |
| Starter Grip .....                           | 14        |
| Steering Friction Bolt .....                 | 15        |
| Tilt Lever .....                             | 15        |
| Transom Angle Adjusting Rod .....            | 16        |
| Engine Cover Lock Lever .....                | 16        |
| Fuel Priming Bulb .....                      | 17        |
| Fuel Filler Cap Vent Knob .....              | 17        |
| <b>FEATURES</b> .....                        | <b>17</b> |
| Fuel Gauge .....                             | 17        |
| Oil Pressure Indicator .....                 | 17        |
| Cooling System Indicator .....               | 17        |
| Anode .....                                  | 18        |
| <br>   |           |
| <b>INSTALLATION</b> .....                    | <b>19</b> |
| <b>POWER REQUIREMENTS</b> .....              | <b>19</b> |
| <b>INSTALLATION POSITION</b> .....           | <b>19</b> |
| <b>OUTBOARD MOTOR ATTACHMENT</b> .....       | <b>20</b> |

# CONTENTS

---

## **INSTALLATION (continued)**

|                                  |    |
|----------------------------------|----|
| MOTOR ANGLE FOR CRUISING .....   | 21 |
| MOTOR ANGLE ADJUSTMENT .....     | 21 |
| BATTERY .....                    | 22 |
| Battery Connections .....        | 22 |
| Battery Installation .....       | 23 |
| EMERGENCY PROCEDURES .....       | 23 |
| Connections to the Battery ..... | 24 |

## **BEFORE OPERATION ..... 25**

|   |    |
|---|----|
| ARE YOU READY TO GET UNDER WAY? .....     | 25 |
| Knowledge .....                           | 25 |
| Safety Apparel .....                      | 25 |
| IS YOUR OUTBOARD MOTOR READY TO GO? ..... | 25 |
| Safety Inspection .....                   | 26 |
| Maintenance Inspection .....              | 26 |

## **OPERATION ..... 27**

|  |    |
|--|----|
| SAFE OPERATING PRECAUTIONS .....                   | 27 |
| BREAK-IN PROCEDURE .....                           | 27 |
| PORTABLE FUEL TANK PLACEMENT AND CONNECTIONS ..... | 27 |
| Fuel Tank Placement .....                          | 27 |
| Fuel Hose Connections .....                        | 28 |
| Fuel Priming .....                                 | 28 |
| STARTING THE ENGINE .....                          | 29 |
| EMERGENCY STARTING .....                           | 33 |
| STOPPING THE ENGINE .....                          | 34 |
| Emergency Engine Stopping .....                    | 34 |
| Normal Engine Stopping .....                       | 34 |
| GEAR SHIFTING .....                                | 35 |
| STEERING .....                                     | 36 |
| CRUISING .....                                     | 37 |
| TILTING THE OUTBOARD MOTOR .....                   | 38 |

## **SERVICING YOUR OUTBOARD MOTOR ..... 40**

|                                     |    |
|-------------------------------------|----|
| THE IMPORTANCE OF MAINTENANCE ..... | 40 |
| MAINTENANCE SAFETY .....            | 41 |
| Safety Precautions .....            | 41 |

|   |           |
|---|-----------|
| <b>SERVICING YOUR OUTBOARD MOTOR (continued)</b>        |           |
| TOOL KIT AND SPARE PARTS .....                          | 42        |
| MAINTENANCE SCHEDULE .....                              | 43        |
| REFUELING .....   | 44        |
| FUEL RECOMMENDATIONS .....                              | 45        |
| COOLING SYSTEM CLEANING AND FLUSHING .....              | 46        |
| Cleaning and Flushing With the Optional Flush Kit ..... | 46        |
| Cleaning and Flushing Without the Flush Kit .....       | 47        |
| ENGINE OIL LEVEL CHECK .....                            | 48        |
| ENGINE OIL CHANGE .....                                 | 49        |
| ENGINE OIL RECOMMENDATIONS .....                        | 50        |
| GEAR CASE OIL LEVEL CHECK .....                         | 51        |
| GEAR CASE OIL CHANGE .....                              | 52        |
| LUBRICATION POINTS .....                                | 53        |
| SPARK PLUG SERVICE .....                                | 54        |
| FUEL FILTER REPLACEMENT .....                           | 55        |
| RECOIL STARTER ROPE INSPECTION .....                    | 57        |
| ANODE REPLACEMENT .....                                 | 57        |
| SHEAR PIN AND PROPELLER REPLACEMENT .....               | 58        |
| ENGINE COVER LOOK ADJUSTMENT .....                      | 59        |
| <b>HELPFUL TIPS AND SUGGESTIONS .....</b>               | <b>60</b> |
| STORING YOUR OUTBOARD MOTOR .....                       | 60        |
| Storage Preparation .....                               | 60        |
| Storage Precautions .....                               | 63        |
| Removal From Storage .....                              | 64        |
| TRANSPORTING .....                                      | 64        |
| <b>TAKING CARE OF UNEXPECTED PROBLEMS .....</b>         | <b>65</b> |
| ENGINE WILL NOT START .....                             | 65        |
| BATTERY DOES NOT CHARGE .....                           | 66        |
| Fuse Replacement .....                                  | 66        |
| SUBMERGED MOTOR .....                                   | 67        |

# CONTENTS

---

|   |                          |
|---|--------------------------|
| <b>TECHNICAL AND CONSUMER INFORMATION .....</b>           | <b>69</b>                |
| TECHNICAL INFORMATION .....                               | 69                       |
| Serial Number Locations .....                             | 69                       |
| Carburetor Modification for High Altitude Operation ..... | 70                       |
| Oxygenated Fuels .....                                    | 71                       |
| Emission Control System Information .....                 | 72                       |
| Star Label .....  | 74                       |
| Specifications .....                                      | 76                       |
| CONSUMER INFORMATION .....                                | 78                       |
| Honda Publications .....                                  | 78                       |
| Customer Service Information .....                        | 79                       |
| Distributor's Limited Warranty .....                      | 83                       |
| Emission Control System Warranty .....                    | 86                       |
| WIRING DIAGRAM .....                                      | 88                       |
| <b>INDEX .....</b>  | <b>89</b>                |
| <b>QUICK REFERENCE INFORMATION .....</b>                  | <b>Inside back cover</b> |



# OUTBOARD MOTOR SAFETY

## IMPORTANT SAFETY INFORMATION

The Honda BF8A outboard motor is designed for use with boats that have a suitable manufacturer's power recommendation, other uses can result in injury to the operator or damage to the outboard motor and other property.

Most accidents can be prevented if you follow all instructions in this manual and on the outboard motor. The most common hazards are discussed below, along with the best way to protect yourself and others.

### Operator Responsibility

- It is the operator's responsibility to provide the necessary safeguards to protect people and property. Know how to stop the engine quickly in case of emergency. Understand the use of all controls.
- Stop the engine immediately if anyone falls overboard, and do not run the engine while the boat is near anyone in the water.
- Always stop the engine if you must leave the controls for any reason.
- Attach the emergency stop switch lanyard securely to the operator.
- Always wear a PFD (PERSONAL FLOTATION DEVICE) while on the boat.
- Familiarize yourself with all laws and regulations relating to the boating and the use of outboard motors.
- Be sure that anyone who operates the outboard motor receives proper instruction.
- Be sure the outboard motor is properly mounted on the boat.
- Do not remove the engine cover while the engine is running.
- Do not attempt to modify the outboard motor.
- Do not remove any labels, covers, or safety devices; they are installed for your safety.

# **OUTBOARD MOTOR SAFETY**

---

## **Refuel With Care**

- Gasoline is extremely flammable, and gasoline vapor can explode. Refuel outdoors, in a well-ventilated area, with the engine stopped. Never smoke near gasoline, and keep other flames and sparks away.
- Remove any portable fuel tank from the boat for refueling. Keep the portable fuel tank away from the battery or other potential spark sources.
- Refuel carefully to avoid spilling fuel. Avoid overfilling the fuel tank.
- After refueling, tighten the filler cap securely. If any fuel is spilled, make sure the area is dry before starting the engine.

## **Carbon Monoxide Hazard**

Exhaust gas contains poisonous carbon monoxide. Avoid inhalation of exhaust gas. Never run the engine in a closed garage or confined area.

# OUTBOARD MOTOR SAFETY

## SAFETY LABEL LOCATIONS

The labels shown here contain important safety information. Please read them carefully. These labels are considered permanent parts of your outboard motor. If a label comes off or becomes hard to read, contact an authorized Honda marine dealer for a replacement.

 **READ OWNER'S MANUAL CAREFULLY BEFORE OPERATION.**

---

 **WARNING**

- PLACE TRANSMISSION IN NEUTRAL BEFORE STARTING.
- DO NOT OPERATE WITH ENGINE COVER REMOVED.
- BE SURE THE ANTIVENTILATION PLATE IS BELOW THE WATER LINE.
- DO NOT SHIFT TO REVERSE SUDDENLY AT HIGH SPEED.

---

- CHECK OIL LEVEL BEFORE STARTING.
- FLUSH THE SYSTEM THOROUGHLY WITH FRESH WATER AFTER EACH USE IN SALT WATER.
- EMERGENCY STARTING INSTRUCTIONS ARE ON TOP OF ENGINE.

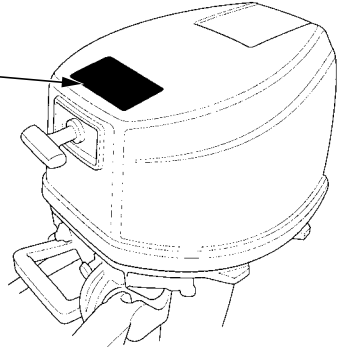

**GASOLINE**      **FLAMMABLE DANGER**

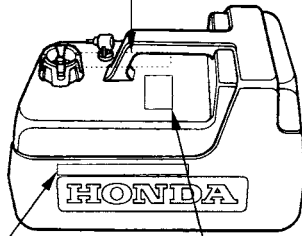

**GASOLINE**      **FLAMMABLE DANGER**

**DANGER**  
HARMFUL OR FATAL IF SWALLOWED.  
KEEP OUT OF REACH OF CHILDREN.  
IF SWALLOWED, DO NOT INDUCE  
VOMITING. CALL A PHYSICIAN  
IMMEDIATELY.

# CONTROLS AND FEATURES

## COMPONENT AND CONTROL LOCATIONS

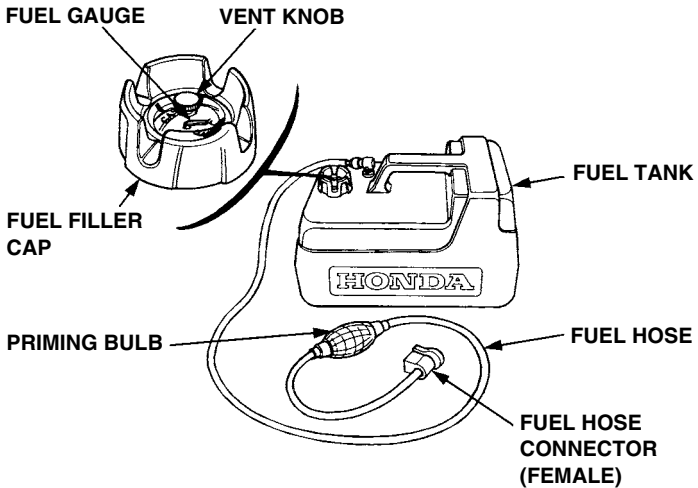
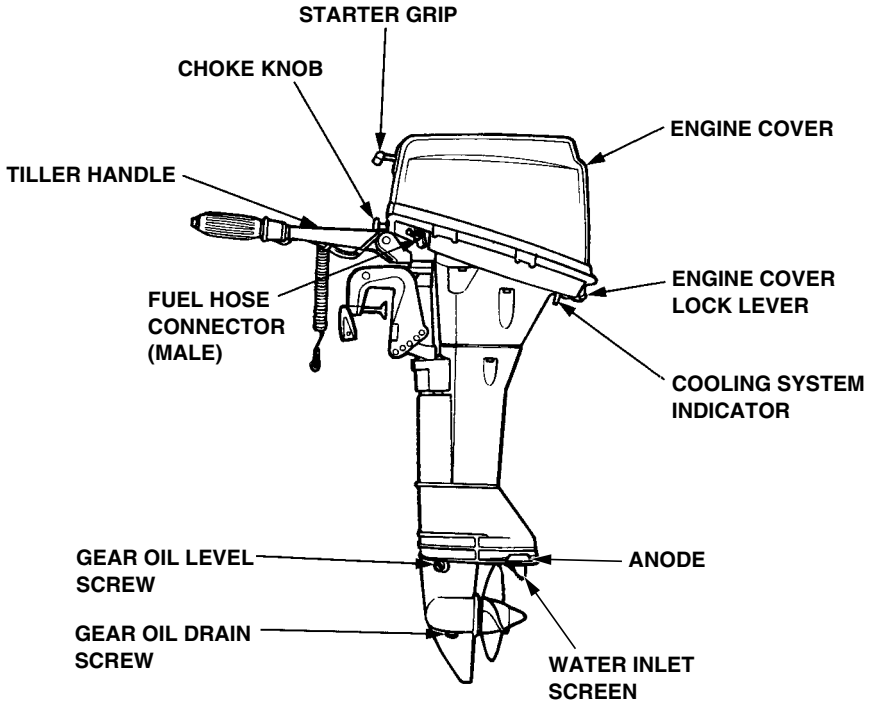

# CONTROLS AND FEATURES

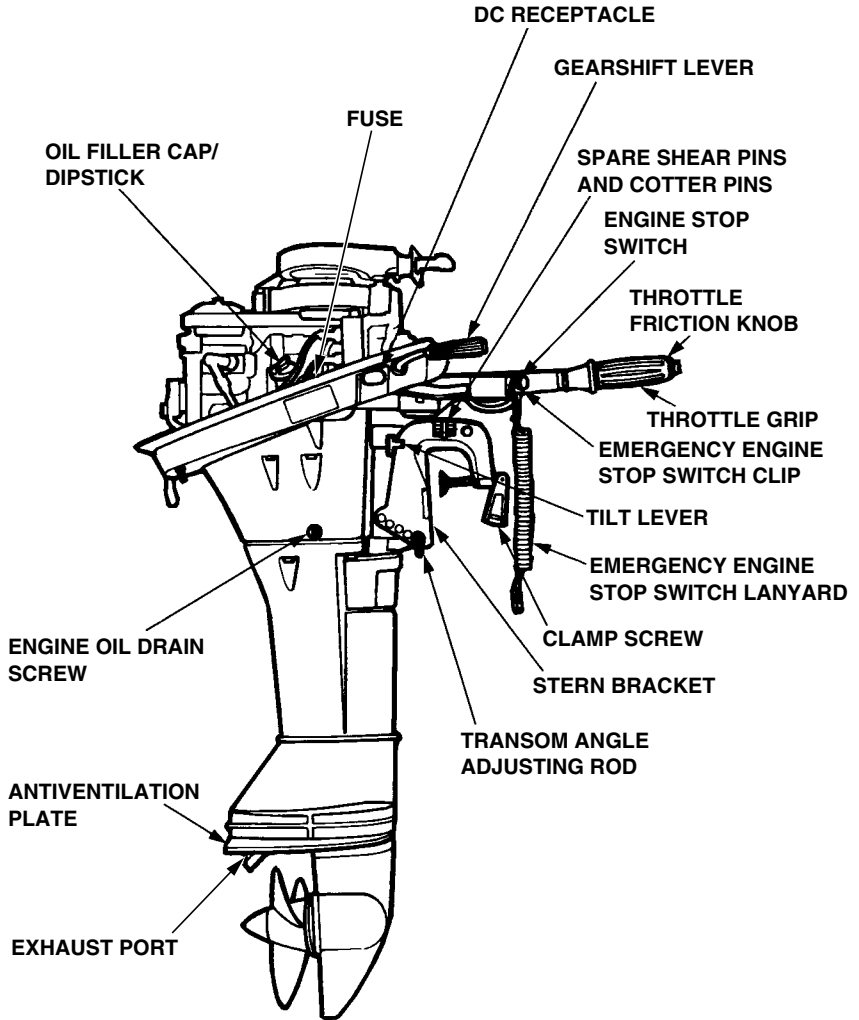

# CONTROLS AND FEATURES

---

## CONTROLS

### Engine Stop Switch and Switch Clip

The engine stop switch has controls for normal engine stopping and emergency engine stopping.

In normal operation, press the engine stop button to stop the engine.

A switch clip and lanyard system stops the engine automatically if the operator falls away from the controls.

The switch clip must be inserted in the engine stop switch in order for the engine to start and run. The other end of the lanyard attaches to the operator's wrist. If the operator falls away from the controls, the lanyard pulls the clip out of the switch.

Always attach the lanyard to your PFD (Personal Flotation Device) or your wrist before operating the outboard motor.

A spare switch clip is supplied with the tool kit.

### Choke knob

The choke knob opens and closes the choke valve in the carburetor.

The ON position enriches the fuel mixture for starting a cold engine.

The OFF position provides the correct fuel mixture for operation after starting, and for restarting a warm engine.

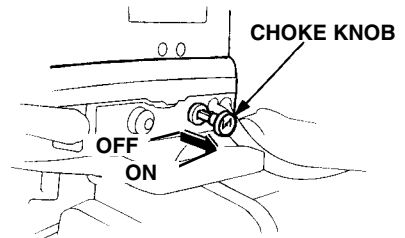
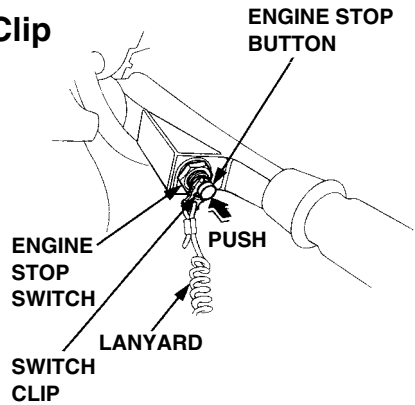

## Throttle Grip

The throttle grip controls engine speed.

An index mark on the tiller arm indicates throttle position.

The gearshift mechanism limits throttle grip movement when the gearshift lever (p. 14) is in the R (reverse) or N (neutral) position.

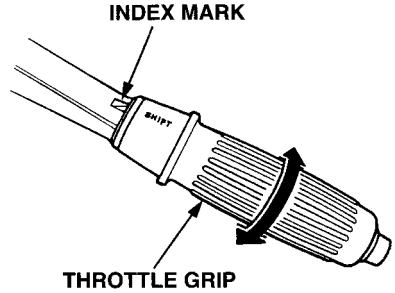

## Throttle Friction Knob

The throttle friction knob adjusts resistance to throttle grip rotation.

Turn the knob clockwise to increase friction for holding a throttle setting while cruising.

Turn the knob counterclockwise to decrease friction for easy throttle grip rotation.

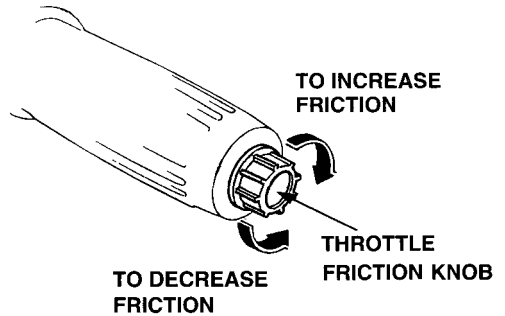

# CONTROLS AND FEATURES

---

## Gearshift Lever

The gearshift lever is used to select F (forward), N (neutral), or R (reverse) gears.

The engine can be started with the gearshift lever in the N (neutral) position only.

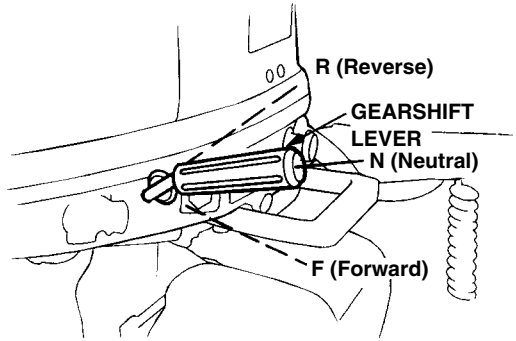

## Starter Grip

Pulling the starter grip operates the recoil starter to crank the engine for starting.

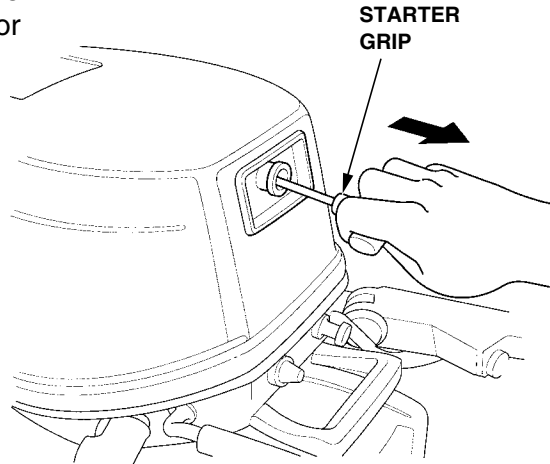



## Steering Friction Bolt

The steering friction bolt adjusts steering resistance.

Turn the bolt clockwise to increase friction for holding a steady course while cruising or to prevent the outboard motor from swinging while trailering the boat.

Turn the bolt counterclockwise to reduce steering friction.

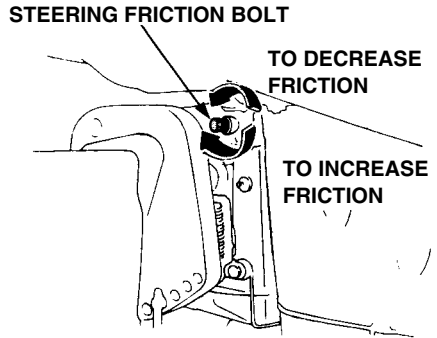

## Tilt Lever

The tilt lever enables the outboard motor to be raised for shallow water operation, beaching, launching, or mooring.

To tilt, move the lever to the TILT position, then raise the outboard motor until the tilt mechanism engages at 30°, 45° or 70° (p. 38).

To return the outboard motor to the normal running position, move the tilt lever to the RUN position, raise the outboard motor slightly to disengage the tilt mechanism, then slowly lower the engine.

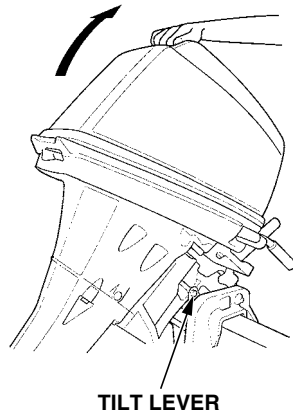

# CONTROLS AND FEATURES

## Transom Angle Adjusting Rod

The transom angle adjusting rod is used to adjust the angle of the outboard motor in the normal operating position (see page 21).

To adjust, first tilt the outboard motor, so it is not resting on the rod.

Push the rod in and turn the end of the rod up, so the latch will fall in line with the rod.

Remove the rod, and reinsert it in the desired position.

Push the rod in and turn the end of the rod down, so the latch will fall to the locked position. Then release the rod.

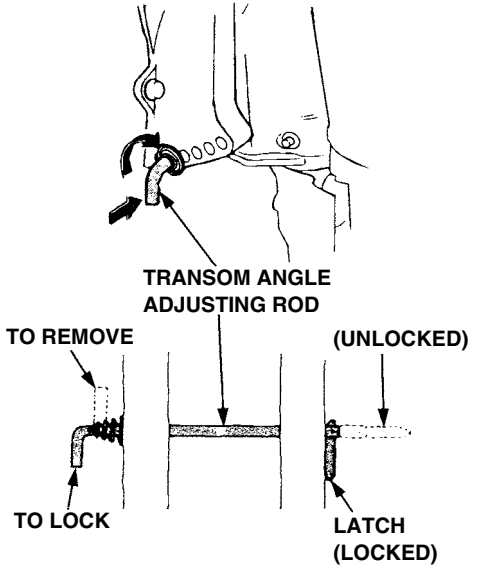

## Engine Cover Lock Lever

The engine cover lock lever fastens the cover to the outboard motor.

To remove the cover, move the lever to the unlocked position, then lift off the cover.

To install the cover, position the cover on the outboard motor, then move the lever to the locked position.

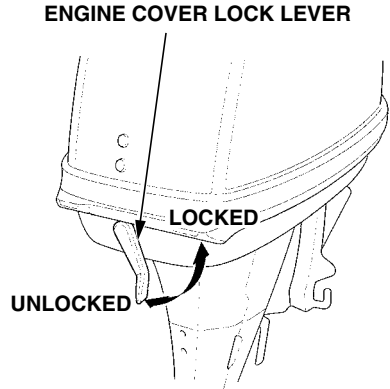

# CONTROLS AND FEATURES

## Fuel Priming Bulb

A priming bulb is built into the fuel hose that connects the portable fuel tank to the outboard motor.

Before operating the outboard motor, squeeze the priming bulb until it feels firm. This will ensure that fuel is supplied to the engine (see page 28).

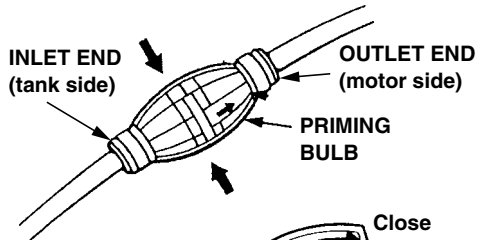

## Fuel Filler Cap Vent Knob

The cap is provided with a vent knob to seal the portable fuel tank for carrying it to and from the boat. Open the vent knob 2 or 3 turns before operating the outboard motor.

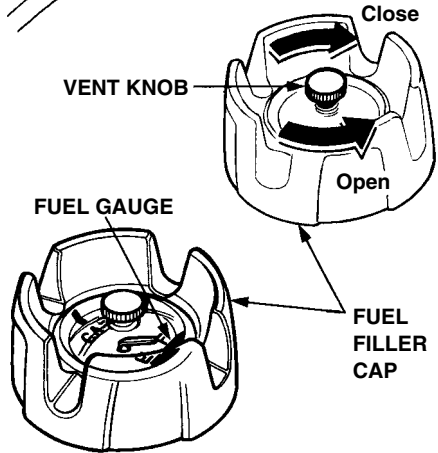

## FEATURES

### Fuel Gauge

A fuel gauge is built into the cap of the portable fuel tank.

### Oil Pressure Indicator

The oil pressure indicator should remain lit while the engine is running. The lit indicator shows that the oil pressure is OK (see page 31).

OIL PRESSURE INDICATOR

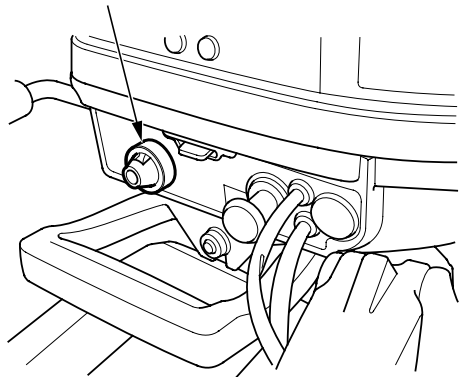

### Cooling System Indicator

Water should flow from the cooling system indicator while the engine is running. This shows that water is circulating through the engine cooling system.

COOLING SYSTEM INDICATOR

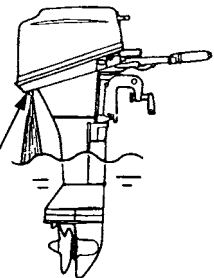

# CONTROLS AND FEATURES

---

## Anode

The anode is made of a sacrificial material that helps to protect the outboard motor from corrosion.

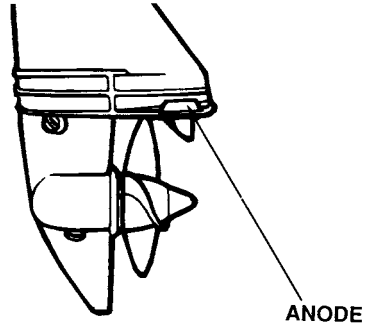

# INSTALLATION

Correct and secure installation is essential for safe boating and good performance. Follow the installation instructions provided in this manual.

## POWER REQUIREMENTS

Before installation, check to be sure that the outboard motor does not exceed the recommended maximum horsepower for the boat on which it is to be installed. Refer to the boat's certification plate for recommended maximum horsepower. If the certification plate information is not available, contact the boat dealer or manufacturer.

For most boat applications, the outboard motor should have a horsepower which provides 80% of the maximum recommended horsepower for the boat.

## INSTALLATION POSITION

Install the outboard motor on the center of the boat transom.

The antiventilation plate of the outboard motor should be 0 – 2 in (0 – 50 mm) below the bottom of the boat. When the outboard motor is mounted on a sailboat, the antiventilation plate should be 6 in (150 mm) or more below the surface of the water. For unusual situations, see your Honda marine dealer for advice.

The correct dimensions differ according to the type of boat and the configuration of the bottom of the boat. Follow the manufacturer's recommended installation height.

| Outboard Motor |                  |
|----------------|------------------|
| Type           | Transom Height   |
| Short : S      | 16.5 in (420 mm) |
| Long : L       | 22.5 in (572 mm) |

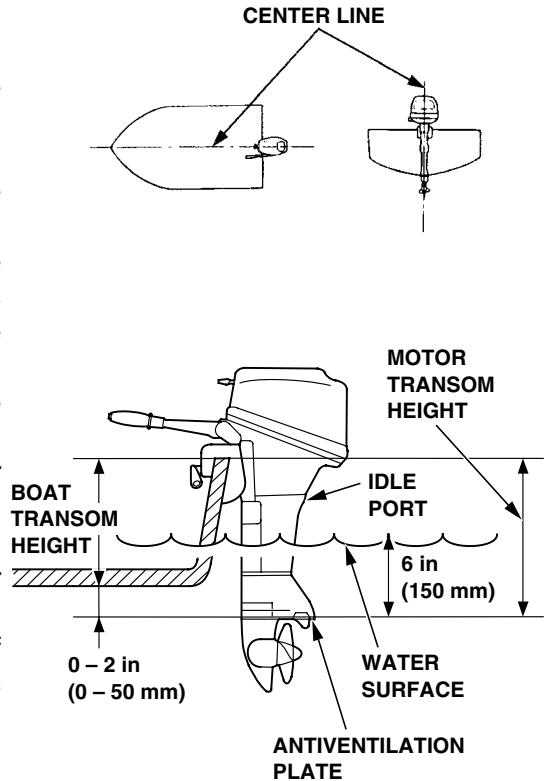

# INSTALLATION

---

When the outboard motor is installed extremely low, the idle port may be immersed and the engine may become hard to start or may run poorly. Check that the idle port is high enough from the water level when the engine is stopped with the boat fully loaded.

If the outboard motor is installed too low, the boat will squat and be hard to plane, and the motor will spray water that may enter the boat. It will tend to porpoise, and high-speed stability will be reduced.

Propeller ventilation will occur if the outboard motor is installed too high on the boat transom.

Optimum installation height varies with boat type and bottom shape. Contact the boat manufacturer for any special recommendations that are unique to a specific model of boat.

If the transom needs to be modified to accommodate the outboard motor, contact the boat manufacturer and follow their recommendations for corrective action.

## OUTBOARD MOTOR ATTACHMENT

Attach the stern bracket to the boat transom by tightening the clamp screws.

### NOTICE

- *Before operating the boat, check the tightness of the clamp screws.*
- *Tie a rope through the hole in the stern bracket and secure the other end of the rope to the boat. This will prevent accidental loss of the motor.*
- *The holes in the clamp screw handles may be padlocked together to prevent theft of the motor.*

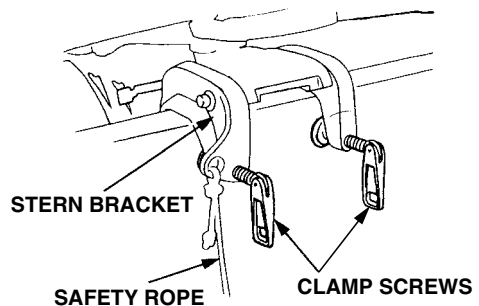

## MOTOR ANGLE FOR CRUISING

Adjust the motor so the propeller shaft is parallel with the water surface.

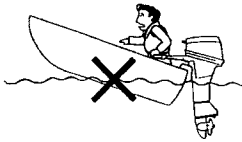

**INCORRECT  
CAUSES BOAT TO  
"SQUAT"**

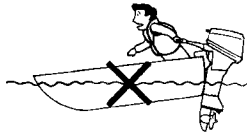

**INCORRECT  
CAUSES BOAT TO  
"PLOW"**

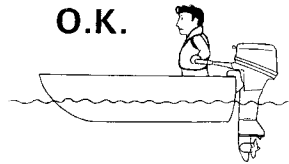

**O.K.  
CORRECT  
GIVES MAXIMUM PERFORMANCE**

## MOTOR ANGLE ADJUSTMENT

If the propeller shaft is not parallel with the water surface, adjust by changing the transom angle adjusting rod position.

There are four adjusting stages.

1. Push in (A) the adjusting rod, twist upwards (B) and pull out to remove.
2. Insert the rod in the proper hole and twist it down to lock.

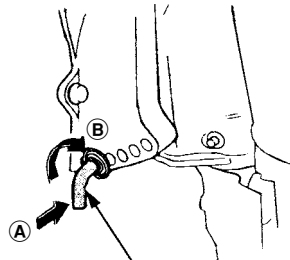

**TRANSOM ANGLE  
ADJUSTING ROD**

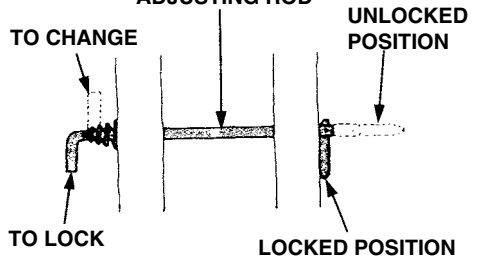

### NOTICE

*To prevent damage to the motor or boat, make sure the transom angle adjusting rod is locked.*

# INSTALLATION

## BATTERY

### Battery Connections

Honda BF8A outboard motors produce a 12-volt, 5-ampere battery-charging current. The motors come with a DC receptacle that needs to be connected to a 12-volt battery. The battery-charging circuit is protected by a 5-ampere fuse located in the engine compartment.

The outboard motor's 12-volt output is designed to charge a "starting or cruising" battery only. It is not intended to charge a "deep-cycle" type battery. Lights and electrical accessories for the boat should be connected to the battery.

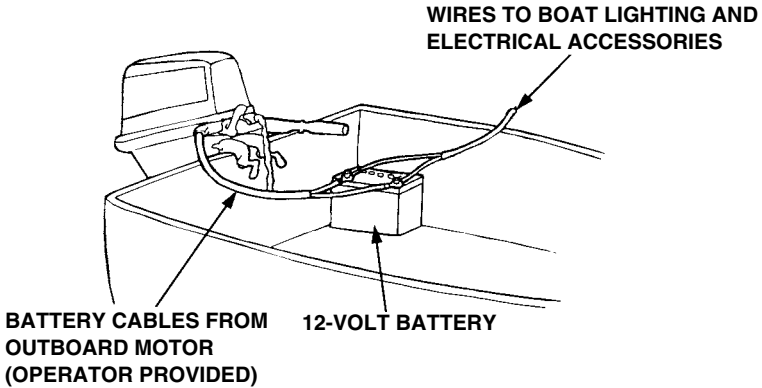

The receptacle is provided with a rubber cap, which should be attached when the plug is removed, in order to keep the receptacle clean and dry.

To prepare the outboard motor for connection to a battery, pull the plug out of its rubber boot, route suitable electrical wires through the boot, and screw them to the plug positive (+) and negative (-) terminals. Coat the plug terminals with dielectric grease, and reinstall the plug in the rubber boot.

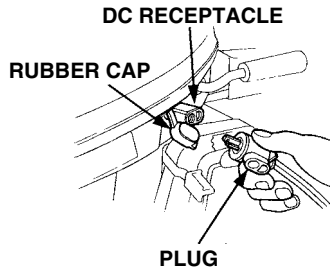



## Battery Installation

Place the battery in a corrosion-resistant battery box that is securely mounted in a location away from the fuel tank and protected from contact with water.

### **WARNING**

The battery contains sulfuric acid (electrolyte), which is highly corrosive and poisonous.

Getting electrolyte in your eyes or on your skin can cause serious burns.

Wear protective clothing and eye protection when working near the battery.

## EMERGENCY PROCEDURES

**Eyes** — Flush with water from a cup or other container for at least 15 minutes (water under pressure can damage the eye). Immediately call a physician, local poison control center, or 911.

**Skin** — Remove contaminated clothing. Flush the skin with large quantities of water. Call a physician immediately.

**Swallowing** — Drink water or milk. Call your local poison control center or a physician immediately.

# INSTALLATION

---

## Connections to the Battery

Connect the positive (+) battery cable to the positive (+) battery terminal, then connect the negative (-) battery cable to the negative (-) battery terminal.

The negative (-) battery cable should always be removed from the battery when connecting or disconnecting the positive (+) battery cable, so tools cannot cause a short circuit if they touch a grounded part while being used on the positive (+) battery terminal fitting.

### NOTICE

*Be careful to avoid connecting the battery in reverse polarity, as this will damage the battery-charging system in the outboard motor.*

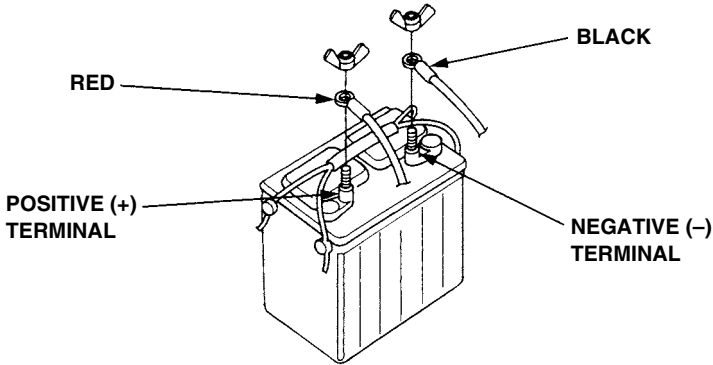

# BEFORE OPERATION

## ARE YOU READY TO GET UNDERWAY?

Your safety is your responsibility. A little time spent in preparation will significantly reduce your risk of injury.

### Knowledge

Read and understand this manual. Know what the controls do and how to operate them.

Familiarize yourself with the outboard motor and its operation before you get underway. Know what to do in case of emergencies.

Familiarize yourself with all laws and regulations relating to boating and the use of outboard motors.

### Safety Apparel

Always wear a PFD while on the boat. Attach the emergency stop switch lanyard securely to your PFD or your wrist.

## IS YOUR OUTBOARD MOTOR READY TO GO?

For your safety, and to maximize the service life of your equipment, it is very important to take a few moments before you operate the outboard motor to check its condition. Be sure to take care of any problem you find, or have your servicing dealer correct it, before you operate the outboard motor.

### **WARNING**

Improperly maintaining this outboard motor, or failing to correct a problem before operation, can cause a malfunction in which you could be seriously hurt or killed.

Always perform a preoperation inspection before each operation, and correct any problem.

# **BEFORE OPERATION**

---

## **Safety Inspection**

- Look around for signs of oil or gasoline leaks. Make sure the fuel tank is in good condition and properly secured in the boat (see page 27). Check that the fuel hose is undamaged and properly connected (see page 28). Wipe up any spills before starting the engine.
- Check the stern bracket to be sure the outboard motor is securely installed.
- Check that all controls are operating properly.
- Replace any damaged parts.
- Check that all fasteners are in place and securely tightened.

## **Maintenance Inspection**

- Check the engine oil level (see page 48). Running the engine with a low oil level can cause engine damage.
- Check to be sure the propeller and shear pin are undamaged, and the propeller cap is secured with a cotter pin (see page 58).
- Check that the anode is securely attached to the antiventilation plate and is not excessively worn (see page 57). The anode helps to protect the outboard motor from corrosion.
- Make sure the tool kit and spare parts are on the boat (see page 42). Replace any missing items.
- Check the fuel hose and the fuel level in the fuel tank (see page 44).

# OPERATION

## SAFE OPERATING PRECAUTIONS

To safely realize the full potential of this outboard motor, you need a complete understanding of its operation and a certain amount of practice with its controls.

Before operating the outboard motor for the first time, please review the *IMPORTANT SAFETY INFORMATION* on page 7 and the chapter titled *BEFORE OPERATION*.

For your safety, avoid starting or operating the engine in an enclosed area, such as a garage. Your engine's exhaust contains poisonous carbon monoxide gas which can collect rapidly in an enclosed area and cause illness or death.

## BREAK-IN PROCEDURE

Proper break-in procedure allows the moving parts to wear in smoothly for best performance and long service life.

For the first 10 hours, run the outboard motor at low speed, and avoid prolonged fullthrottle operation.

## PORTABLE FUEL TANK PLACEMENT AND CONNECTIONS

### Fuel Tank Placement

Place the portable fuel tank in a well-ventilated location, away from direct sunlight.

### WARNING

Gasoline is highly flammable and explosive.

You can be burned or seriously injured when handling fuel.

- Stop the engine and keep heat, sparks and flame away.
- Handle fuel only outdoors.
- Wipe up spills immediately.

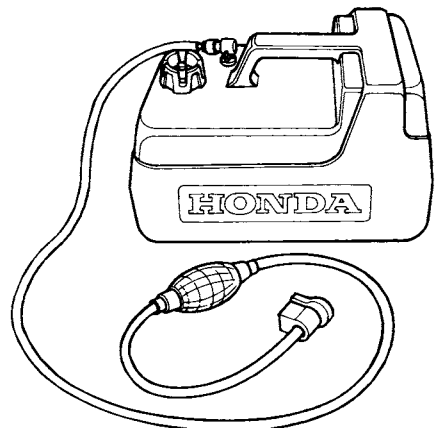

# OPERATION

To ensure that the outboard motor will be able to draw fuel from the tank, place the tank within 6 feet of the outboard motor and not more than 3 feet below the fuel connector on the outboard motor.

Secure the portable fuel tank in the boat, so it won't move around and become damaged.

Before use, open the fuel tank vent by turning the vent knob at least 2 or 3 turns counterclockwise.

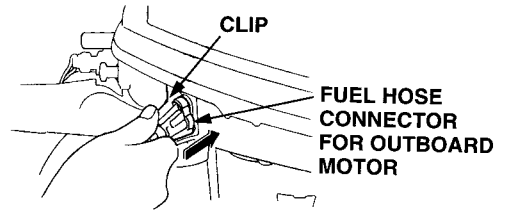
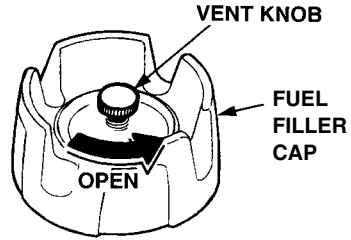

## Fuel Hose Connections

Connect the fuel hose to the tank and the outboard motor, as shown. Be sure both connectors snap securely into place.

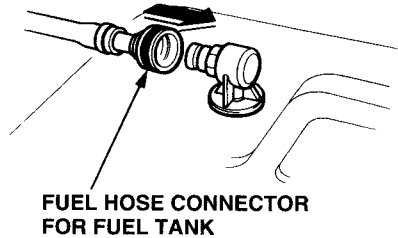

## Fuel Priming

Hold the priming bulb with the outlet end higher than the inlet end. Squeeze the priming bulb several times, until it feels firm, indicating that fuel has reached the carburetor.

Check to be sure there are no fuel leaks before starting the engine.

Do not touch the priming bulb with the engine running or when tilting up the outboard motor. The carburetor could overflow.

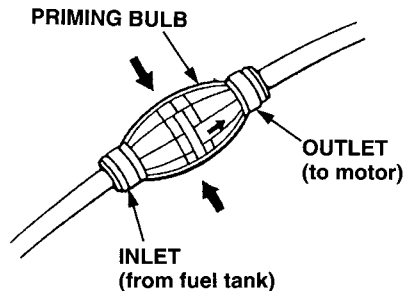

## STARTING THE ENGINE

1. Put the emergency engine stop switch clip in the engine stop switch, and attach the lanyard to your PFD or your wrist.

The engine will not start or run, unless the clip is in the switch.

The emergency engine stop switch clip and lanyard system is a safety device that will stop the engine if you fall away from the controls while operating the boat.

Always attach the lanyard to your PFD or your wrist before starting the engine.

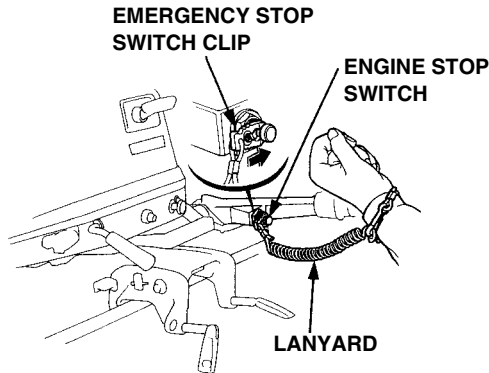

2. Check the position of the gearshift lever. It must be in the N (neutral) position for starting.

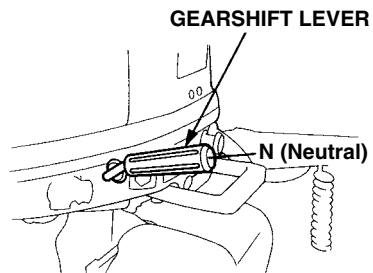

# OPERATION

3. Align the throttle grip START position with the mark on the tiller handle.

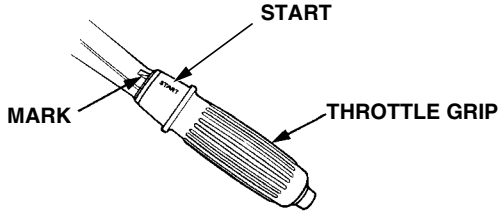

4. To start a cold engine, pull out the choke knob to the ON position. To restart a warm engine, leave the choke knob pushed in.

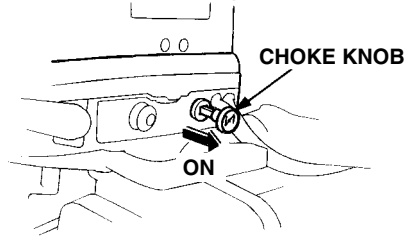

5. Pull the starter grip lightly until you feel resistance, then pull briskly in the direction of the arrow as show below.

## NOTICE

- *Do not allow the starter grip to snap back against the engine. Return it gently to prevent damage to the starter.*
- *Do not pull the starter grip while the engine is running, as that may damage the starter.*

If the engine fails to start, check the engine stop switch clip and verify that the gearshift lever is in the neutral position.

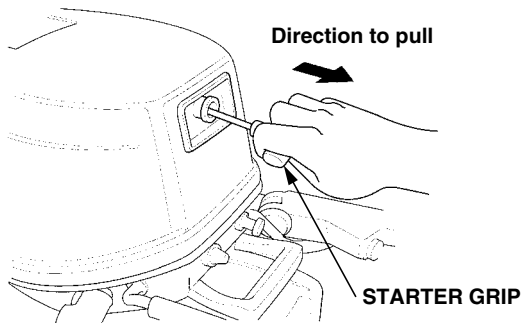



6. After starting, check the oil pressure indicator. The indicator should be on while the engine is running. If the indicator is off, stop the engine immediately, check the engine oil level, and inspect the engine for oil leaks.

### OIL PRESSURE INDICATOR

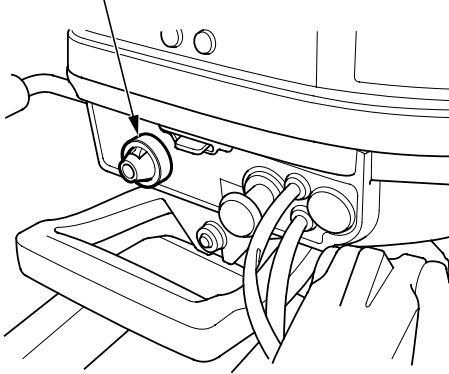

If the oil level is OK, but the indicator stays off while the engine is running, take the motor to an authorized Honda marine dealer immediately.

# OPERATION

---

7. After starting, be sure water is flowing out of the cooling system indicator.

## NOTICE

*If water does not flow out, or if steam comes out, stop the engine. Check to see if the screen in the cooling water inlet is obstructed. Do not operate the engine until the problem has been corrected.*

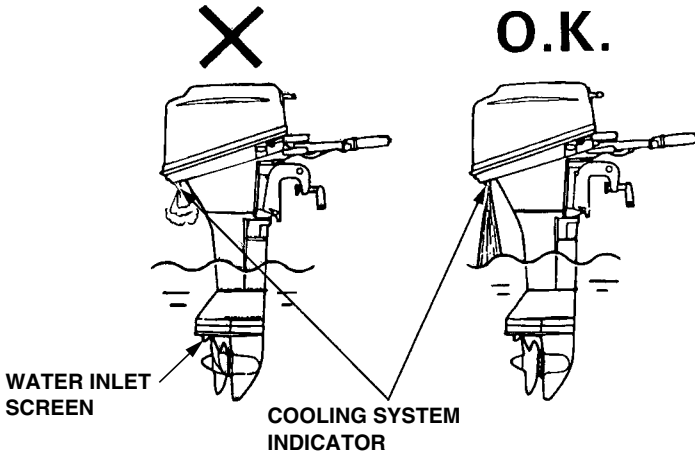

8. If the choke was used, push it in gradually as the engine warms up.

9. Before leaving the dock, check the operation of the emergency engine stop switch.

## EMERGENCY STARTING

If the recoil starter is not working properly, the engine can be started with the emergency starter rope in the tool kit.

1. Remove the engine cover.
2. Remove the recoil starter by removing the three 6 mm bolts.
3. Follow steps 1 through 4 of the normal engine starting procedure (see pages 29 and 30).
4. Wind the emergency starter rope clockwise around the pulley, and then pull it straight out to start the engine. Keep clear of moving parts.
5. Leave the recoil starter off and reinstall engine cover.

### **⚠ WARNING**

Exposed moving parts can cause injury. Use extreme care when installing the engine cover. Do not operate the outboard motor without the engine cover.

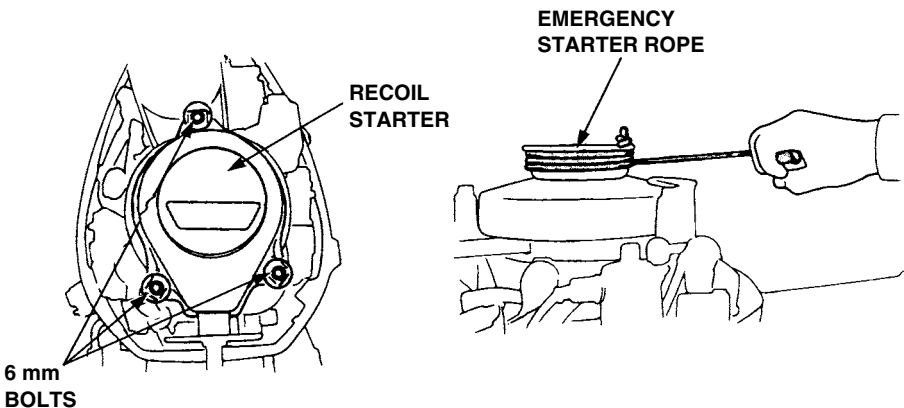

# OPERATION

## STOPPING THE ENGINE

### Emergency Engine Stopping

Disengage the emergency engine stop switch clip from the engine stop switch by pulling the lanyard.

It is a good idea to stop the engine with the emergency engine stop switch lanyard from time to time to be sure that the switch is operating properly.

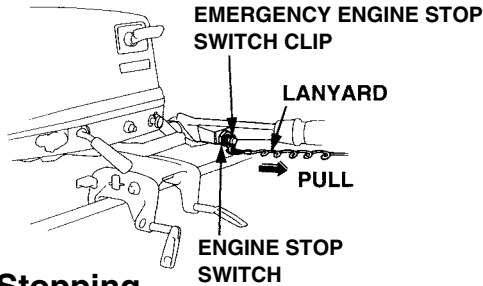

### Normal Engine Stopping

1. Turn the throttle grip to the SHIFT position, and move the gearshift lever to the N (neutral) position.

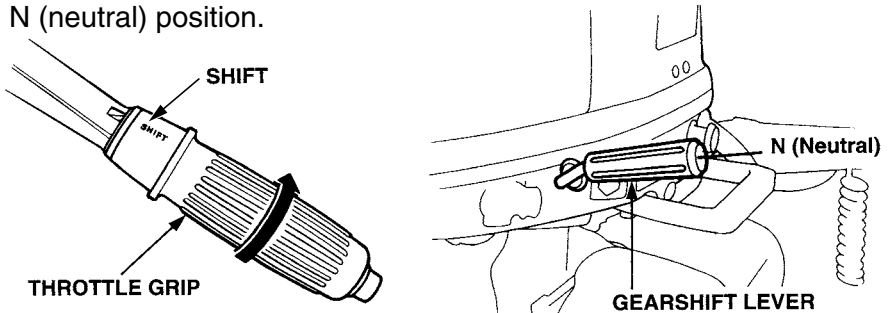

2. Push the engine stop switch button until the engine stops.

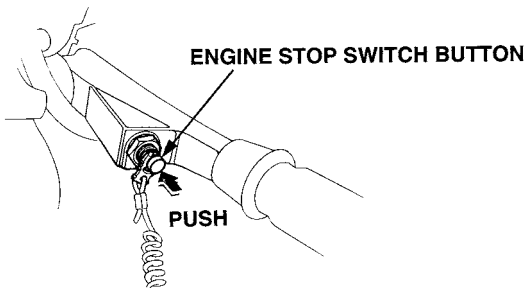

In the event that the engine does not stop when you push the engine stop switch button, pull the emergency engine stop switch lanyard. If the engine continues to run, pull the choke knob to stop the engine.

## GEAR SHIFTING

Put the tilt lever in the RUN position to prevent the outboard motor from tilting up when operating in reverse (refer to page 38).

The gearshift lever has 3 positions : FORWARD, NEUTRAL, and REVERSE. An indicator at the base of the gearshift lever aligns with letters F, N, or R on the engine case to show the gear that has been selected.

Turn the throttle grip to SHIFT to decrease engine speed before moving the gearshift lever.

### NOTICE

*When operating in reverse, proceed with caution to avoid hitting any underwater obstructions with the propeller.*

The gear shift mechanism limits throttle opening in the N (neutral) and R (reverse) positions. The outboard motor allows the throttle to be opened to FAST with the gear shift lever in the F (forward) position.

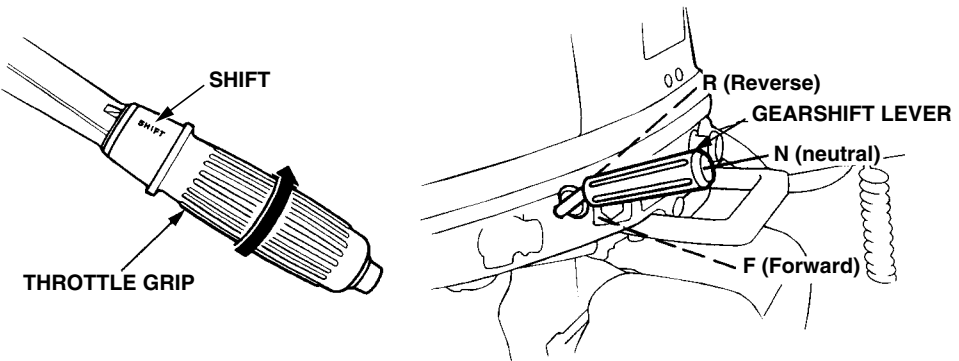

# OPERATION

---

## STEERING

To turn to the right, swing the tiller handle to the left. To turn to the left, swing the tiller handle to the right.

Boats equipped with a remote control steering wheel are controlled in the same way as a car.

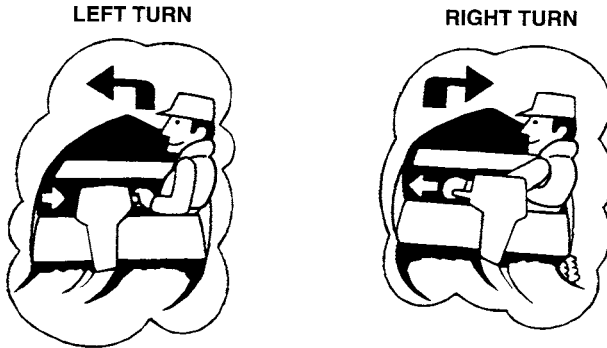

Swing the tiller handle to the right.

Swing the tiller handle to the left.

The tiller handle steering friction should be adjusted so that stable boat operation is maintained with a minimum of operator effort.

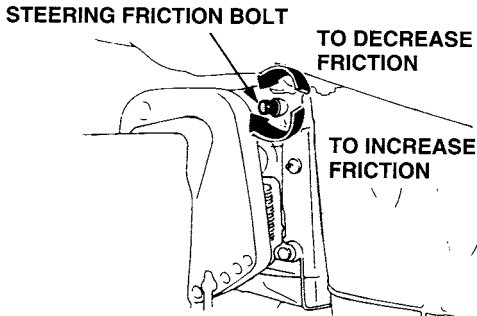

## CRUISING

With the gearshift lever in the forward position F, turn the throttle grip toward FAST to increase speed. For normal cruising, open the throttle about 3/4.

To hold the throttle at a steady setting, turn the throttle friction knob clockwise. To free the throttle grip for manual speed control, turn the friction knob counterclockwise.

For best performance, passengers and equipment should be distributed evenly to balance the boat.

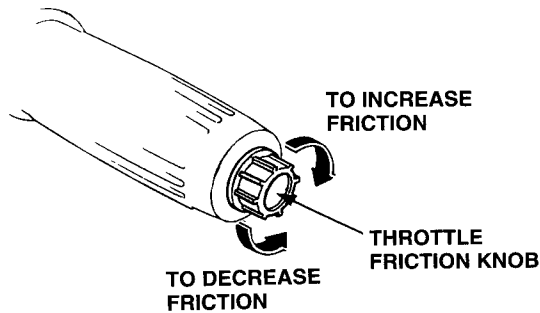
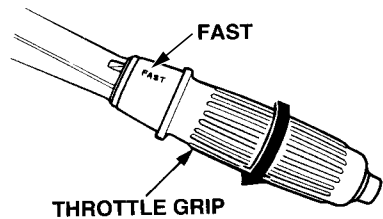
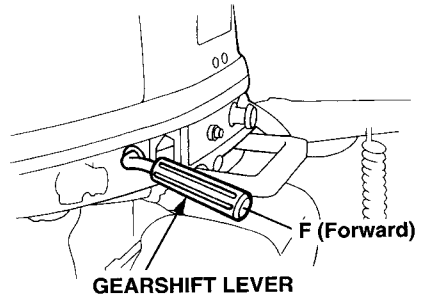

# OPERATION

## TILTING THE OUTBOARD MOTOR

Tilt the motor to prevent the propeller and gear case from hitting bottom when the boat is beached or stopped in shallow water.

1. Stop the engine and put the gearshift lever into NEUTRAL.
2. Pull the tilt lever toward you, set the lever in the TILT position, and raise the engine to either the 30°, 45° or 70° tilt position.

### NOTICE

*Do not use the throttle grip or the tiller handle to tilt the outboard motor. The throttle grip is not designed to tilt the engine and may be damaged.*

3. To return the engine to the normal RUN position, move the tilt lever away from you until it stops, tilt the engine up slightly, then lower the engine slowly.

### NOTICE

- *Make sure water comes out from the cooling system indicator.*
- *When the outboard motor is tilted, cruise at low speed.*
- *Never operate in reverse when the outboard motor is tilted, because the outboard motor will rise suddenly.*
- *Excessive tilt angle during operation can cause propeller ventilation, overheating, and water pump damage. This type of damage is not covered by the Distributor's Limited Warranty (p. 83).*

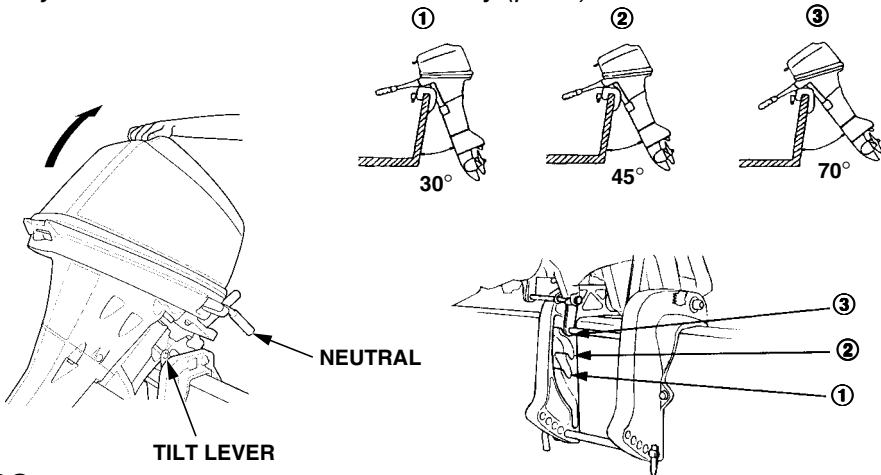



## NOTICE

*To avoid damaging the motor, be very careful when mooring a boat, especially when its motor is tilted up. Don't allow the motor to strike against the pier or other boats.*

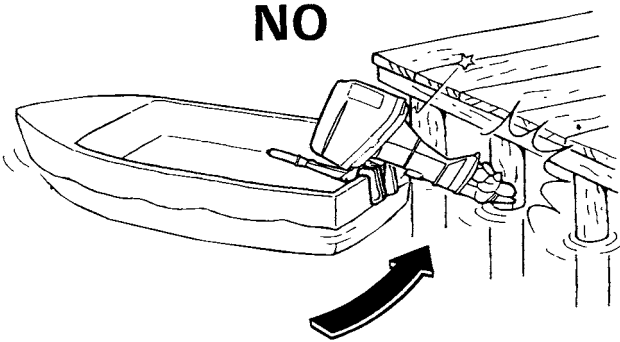

# SERVICING YOUR OUTBOARD MOTOR

## THE IMPORTANCE OF MAINTENANCE

Proper maintenance is essential for safe, economical, and trouble-free operation. It will also help reduce air pollution.

### **WARNING**

Improperly maintaining this outboard motor, or failure to correct a problem before operation, can cause a malfunction in which you could be seriously hurt or killed.

Always follow the inspection and maintenance recommendations and schedules in this owner's manual.

To help you properly care for your outboard motor, the following pages include a maintenance schedule, routine inspection procedures, and simple maintenance procedures using basic hand tools. Other service tasks that are more difficult, or require special tools, are best handled by professionals and are normally performed by a Honda technician or other qualified mechanic.

The maintenance schedule applies to normal operating conditions. If you operate your outboard motor under unusual conditions, consult an authorized Honda marine dealer for recommendations applicable to your individual needs and use.

Remember that your authorized Honda marine dealer knows your outboard motor best and is fully equipped to maintain and repair it.

To ensure the best quality and reliability, use only new, genuine Honda parts or their equivalents for repair and replacement.

**Maintenance, replacement, or repair of emission control devices and systems may be performed by any marine engine repair establishment or individual, using parts that are “certified” to EPA standards.**

# SERVICING YOUR OUTBOARD MOTOR

## MAINTENANCE SAFETY

Some of the most important safety precautions follow. However, we cannot warn you of every conceivable hazard that can arise in performing maintenance. Only you can decide whether or not you should perform a given task.

### **WARNING**

Failure to properly follow maintenance instructions and precautions can cause you to be seriously hurt or killed.

Always follow the procedures and precautions in the owner's manual.

## Safety Precautions

- Make sure the engine is off before you begin any maintenance or repairs. This will eliminate several potential hazards:
  - **Carbon monoxide poisoning from engine exhaust.**  
Be sure there is adequate ventilation whenever you operate the engine.
  - **Burns from hot parts.**  
Let the engine and exhaust system cool before touching.
  - **Injury from moving parts.**  
Do not run the engine unless instructed to do so.
- Read the instructions before you begin, and make sure you have the tools and skills required.
- To reduce the possibility of fire or explosion, be careful when working around gasoline. Use only a nonflammable solvent, not gasoline, to clean parts. Keep cigarettes, sparks, and flames away from all fuel-related parts.
- Wear gloves when handling the propeller to protect your hands from sharp edges.

# SERVICING YOUR OUTBOARD MOTOR

## TOOL KIT AND SPARE PARTS

The following tools and spare parts are supplied with the outboard motor for simple maintenance, adjustment, and emergency repairs.

Spare shear pins and cotter pins are located on the stern bracket.

Keep these items on the boat, so they will always be available if you need them.

If your tool kit needs replacement, it is not available as a kit and each item must be ordered individually.

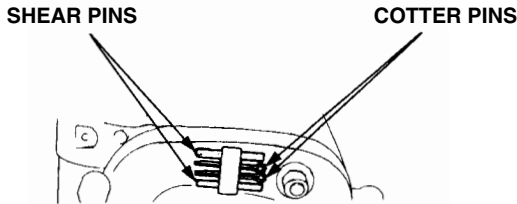

## Tool Kit

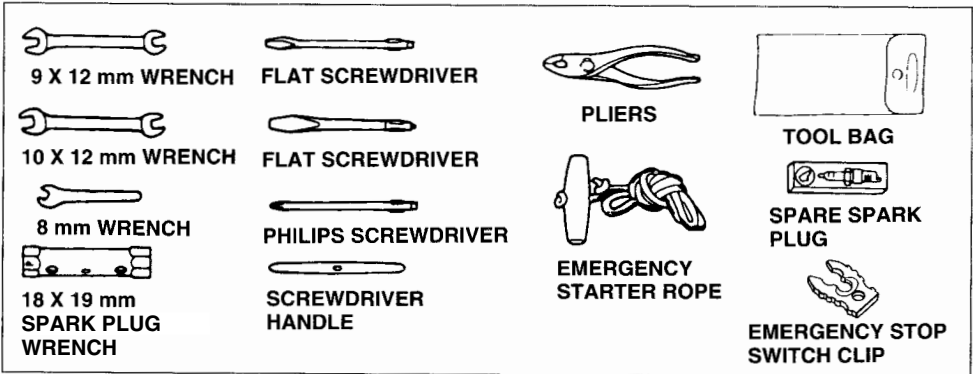

## Flush Kit (optional equipment)

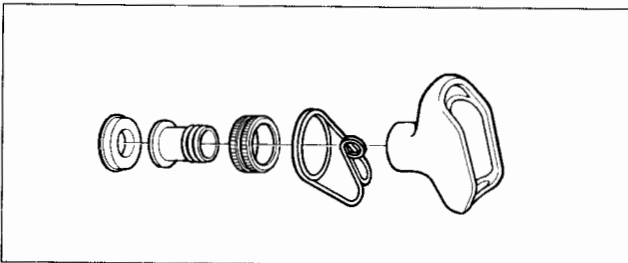

# SERVICING YOUR OUTBOARD MOTOR

## MAINTENANCE SCHEDULE

Follow the MAINTENANCE SCHEDULE table and service your outboard motor accordingly. Please note, a claim for warranty coverage will not be denied simply because the maintenance schedule for your outboard was not followed. However, any part(s) that fails specifically due to lack of maintenance, or improperly performed maintenance, would not be covered under the *Distributor's Limited Warranty*.

| REGULAR SERVICE PERIOD (3)<br>Perform at every indicated month or<br>operating hour interval, whichever<br>comes first. |                 | Each<br>use | After<br>use                    | First<br>month<br>or<br>20 hrs. | Every<br>6 months<br>or<br>100 hrs. | Every<br>year<br>or<br>200 hrs. |
|---|-----------------|-------------|---------------------------------|---------------------------------|-------------------------------------|---------------------------------|
| ITEM  |                 |             |                                 |                                 |                                     |                                 |
| Engine oil  | Check level     | ○           |                                 |                                 |                                     |                                 |
|   | Change          |             |                                 | ○                               | ○                                   |                                 |
| Gear case oil   | Change          |             |                                 | ○                               | ○                                   |                                 |
| Timing belt   | Check           |             |                                 |                                 |                                     | ○(2)                            |
| Starter rope  | Check           |             |                                 |                                 | ○                                   |                                 |
| Carburetor linkage  | Check-adjust    |             |                                 | ○(2)                            | ○(2)                                |                                 |
| Valve clearance   | Check-adjust    |             |                                 |                                 |                                     | ○(2)                            |
| Spark plugs   | Check-adjust    |             |                                 |                                 | ○                                   |                                 |
|   | Replace         |             |                                 |                                 |                                     | ○                               |
| Propeller and Cotter pin  | Check           | ○           |                                 |                                 |                                     |                                 |
| Anode   | Check           | ○           |                                 |                                 |                                     |                                 |
| Idle speed  | Check-adjust    |             |                                 | ○(2)                            | ○(2)                                |                                 |
| Lubrication   | Grease          |             |                                 | ○(1)                            | ○(1)                                |                                 |
| Fuel tank and tank filter   | Clean           |             |                                 |                                 |                                     | ○                               |
| Thermostat  | Check           |             |                                 |                                 |                                     | ○(2)                            |
| Fuel filter   | Check           |             |                                 |                                 | ○                                   |                                 |
|   | Replace         |             |                                 |                                 |                                     | ○                               |
| Fuel line   | Check           | ○           |                                 |                                 |                                     |                                 |
|   | Replace         |             | Every 2 years (if necessary)(2) |                                 |                                     |                                 |
| Bolts and Nuts  | Check-tightness |             |                                 | ○(2)                            | ○(2)                                |                                 |
| Crankcase breather tube   | Check           |             |                                 |                                 |                                     | ○(2)                            |
| Cooling water passages  | Clean           |             | ○(4)                            |                                 |                                     |                                 |
| Water pump  | Check           |             |                                 |                                 |                                     | ○(2)                            |

- (1) Lubricate more frequently when used in salt water.
- (2) These items should be serviced by an authorized Honda marine dealer, unless you have the proper tools and are mechanically proficient.  
Refer to Honda Shop Manual for service procedures.
- (3) For professional commercial use, log hours of operation to determine proper maintenance intervals.
- (4) When operating in salt water, turbid or muddy water, the engine should be flushed with clean water after each use.

# SERVICING YOUR OUTBOARD MOTOR

## REFUELING

**Fuel tank capacity**  
**3.0 US gal (12 ℓ , 2.6 Imp gal)**

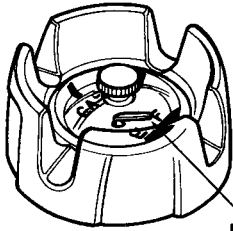

**FUEL GAUGE**

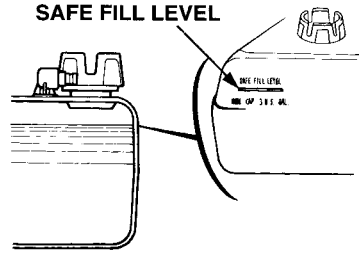

Check the fuel gauge and refill the tank to the **SAFE FILL LEVEL** mark if necessary.

### **⚠ WARNING**

Gasoline is highly flammable and explosive.

You can be burned or seriously injured when handling fuel.

- Stop the engine and keep heat, sparks, and flame away.
- Handle fuel only outdoors.
- Wipe up spills immediately.

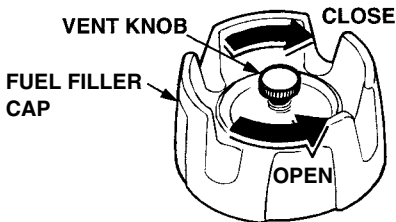

Remove the fuel tank from the boat for refilling. Turn the vent knob counter-clockwise to the open position and remove the fuel filler cap.

Refuel in a well-ventilated area. Fill the fuel tank up to the **SAFE FILL LEVEL** mark only. Inspect the condition of the fuel filler cap gasket and replace if necessary.

After refilling, install and tighten the fuel filler cap securely. Turn the vent knob clockwise to the closed position. Return the fuel tank to the boat.

# SERVICING YOUR OUTBOARD MOTOR

---

## FUEL RECOMMENDATIONS

**Use unleaded gasoline with a pump octane rating of 86 or higher.**

This outboard motor is certified to operate on unleaded gasoline. Unleaded gasoline produces fewer engine and spark plug deposits and extends exhaust system life.

Never use stale or contaminated gasoline or an oil/gasoline mixture. Avoid getting dirt or water in the fuel tank.

If your outboard will be used on an infrequent or intermittent basis, please refer to the fuel section of the *STORAGE* chapter (p. 60) for additional information regarding fuel deterioration.

Occasionally you may hear a light “spark knock” or “pinging” (metallic rapping noise) while operating under heavy loads. This is no cause for concern.

If spark knock or pinging occurs at a steady engine speed, under normal load, change brands of gasoline. If spark knock or pinging persists, see an authorized Honda marine dealer.

### **NOTICE**

*Running the engine with persistent spark knock or pinging can cause engine damage.*

Running the engine with persistent spark knock or pinging is misuse, and the *Distributor's Limited Warranty* (p. 83) does not cover parts damaged by misuse.

For information regarding oxygenated fuels, please refer to page 71.

# SERVICING YOUR OUTBOARD MOTOR

## COOLING SYSTEM CLEANING AND FLUSHING

After each use in salt water or dirty water, thoroughly clean and flush the outboard motor.

### **WARNING**

- For safety, the propeller must be removed.
- Be sure the outboard motor is securely mounted, and do not leave it unattended while running.
- Keep children and pets away from the area, and stay clear of moving parts during this procedure.

### **NOTICE**

*Running the engine without water can cause serious engine damage due to overheating. Be sure that water flows from the cooling system indicator while the engine is running. If not, stop the engine and determine the cause of the problem.*

## Cleaning and Flushing With the Optional Flush Kit

1. Wash the outside of the outboard motor with clean, fresh water.
2. Attach a hose from a fresh water faucet to the water hose connector of the flush kit.
3. Remove the propeller (see page 58), and clip the flush kit rubber fitting over the water inlet screen as shown.
4. Turn on the fresh water supply to the hose.
5. Start the engine and run in neutral for 10 minutes.

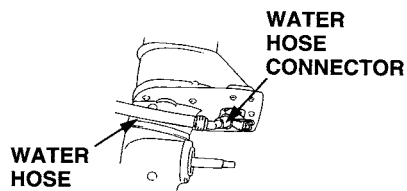
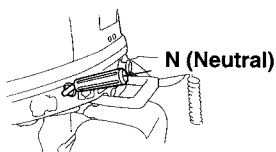



# SERVICING YOUR OUTBOARD MOTOR

---

## Cleaning and Flushing Without the Flush Kit

1. Wash the outside of the outboard motor with clean, fresh water to remove mud, salt, sea weed, etc.
2. Remove the propeller.
3. Stand the motor in a suitable container of water. The water level must be at least 2 inches above the antiventilation plate.
4. Start the engine and run slowly for at least 10 minutes.

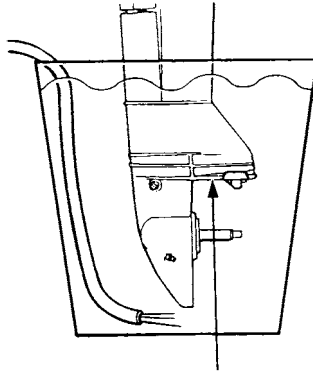

ANTIVENTILATION PLATE

# SERVICING YOUR OUTBOARD MOTOR

## ENGINE OIL LEVEL CHECK

Check the engine oil level with the engine stopped and the outboard motor in a vertical position.

1. Move the engine cover lock lever down to unlock the cover, and remove the cover.
2. Remove the oil filler cap/dipstick and wipe it clean.

Insert and remove the dipstick without screwing it into the filler neck. Check the oil level shown on the dipstick.

If the oil level is near or below the lower limit mark on the dipstick, fill with the recommended oil (p. 50) to the upper limit mark.

### NOTICE

*Running the engine with a low oil level can cause engine damage.*

3. Install the oil filler cap and tighten it securely.
4. Install the engine cover, and lock it by moving the lever up.

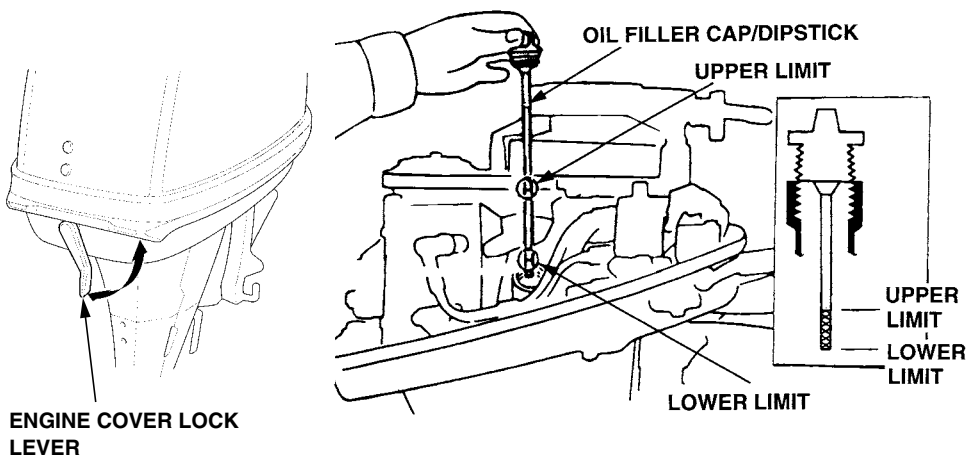

# SERVICING YOUR OUTBOARD MOTOR

## ENGINE OIL CHANGE

An engine oil evacuation device may be used to remove the engine oil. Drain the used oil while the engine is warm. Warm oil drains quickly and completely.

1. Move the engine cover lock lever (p. 48) down to unlock the cover, and remove the cover.
2. Place a suitable container below the engine oil drain location to catch the used oil, then remove the oil filler cap and the drain screw.
3. Allow the used oil to drain completely, then reinstall the drain screw with a new sealing washer, and tighten it securely.

### NOTICE

*Improper disposal of engine oil can be harmful to the environment. If you change your own oil, please dispose of the used oil properly. Put it in a sealed container, and take it to a recycling center. Do not discard it in a trash bin, dump it on the ground or pour it down a drain.*

4. With the outboard motor in a vertical position, fill to the upper limit mark on the dipstick (p. 48) with the recommended oil (p. 50).
5. Install the oil filler cap and tighten it securely.
6. Install the engine cover, and lock it by moving the lever up.

OIL FILLER CAP/DIPSTICK

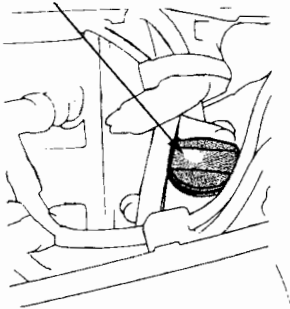

OIL DRAIN SCREW

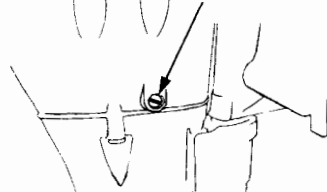

# SERVICING YOUR OUTBOARD MOTOR

---

## ENGINE OIL RECOMMENDATIONS

Oil is a major factor affecting performance and service life. Use 4-stroke automotive detergent oil.

SAE 10W-30 is recommended for general use.

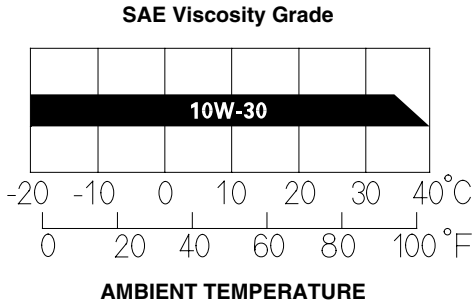

The SAE oil viscosity and service classification are in the API label on the oil container. Honda recommends that you use API SERVICE category SG or later oil with the “starburst” certification mark displayed on the container.

# SERVICING YOUR OUTBOARD MOTOR

---

## GEAR CASE OIL LEVEL CHECK

Check the oil level when the motor is in the vertical position. Remove the oil level screw and see if oil flows out.

If no oil flows out, use a commercially available oil pump or squeeze tube to fill the gear case with the gear oil recommended on page 52. Pump or squeeze fresh oil through the OIL DRAIN screw hole until oil begins flowing out through the OIL LEVEL screw hole.

If there is water in the oil, the water will flow out first when the oil drain screw is removed, or the oil will be a milky color. If water is detected in the oil, the outboard motor should be inspected by an authorized Honda marine dealer.

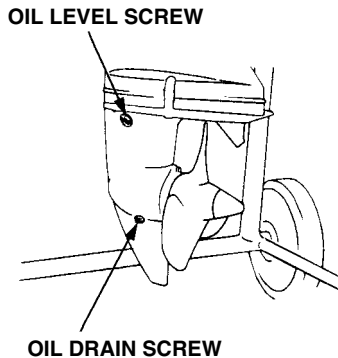

# SERVICING YOUR OUTBOARD MOTOR

---

## GEAR CASE OIL CHANGE

**Recommended oil** : API standard (GL-4/5)  
SAE 90 outboard motor gear oil

**Oil Capacity** : 0.24 US qt (0.23 ℓ, 0.20 Imp qt)

Remove the oil level screw and drain screw and allow the gear oil to thoroughly drain into a suitable container.

Pump or squeeze the recommended gear oil through the OIL DRAIN screw hole until oil starts flowing out through the OIL LEVEL screw hole.

Use new sealing washers. Install the oil level screw first and then the oil drain screw. Tighten securely.

OIL LEVEL SCREW

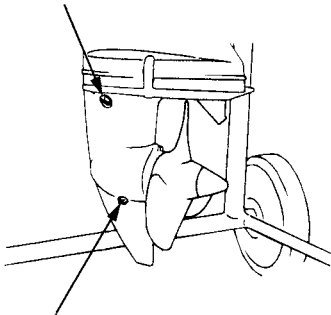

OIL DRAIN SCREW

OIL PUMP

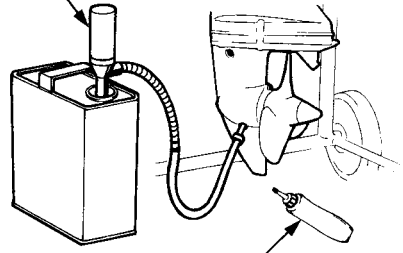

SQUEEZE TUBE

# SERVICING YOUR OUTBOARD MOTOR

## LUBRICATION POINTS

Apply marine waterproof grease to the following parts:

Lubrication interval:

20 operating hours or one month after date of purchase or initial use, then every 100 operating hours or 6 months.

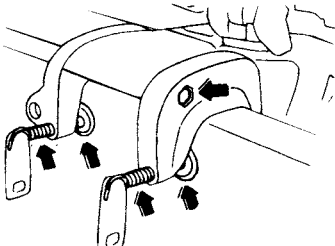

CLAMP SCREWS

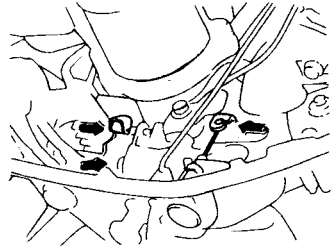

THROTTLE CABLE AND PIVOT  
SHIFT SHAFT AND PIVOT

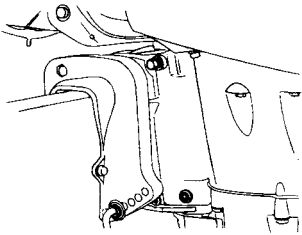

SWIVEL CASE

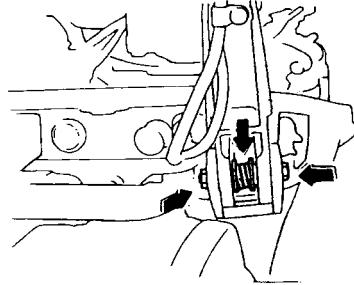

HANDLE PIVOT

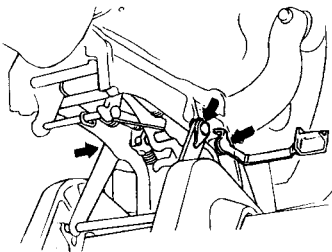

TILT LINKAGE

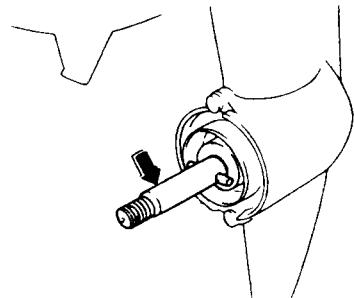

PROPELLER SHAFT

Apply Honda Marine Corrosion Inhibitor (or equivalent) to all areas under the engine cover and any exposed metal surfaces except the belt.

### NOTICE

*To prevent corrosion, apply anticorrosion oil to pivot surfaces where grease cannot penetrate.*

# SERVICING YOUR OUTBOARD MOTOR

## SPARK PLUG SERVICE

**Recommended spark plug: DR-5HS (NGK)**

### NOTICE

*Incorrect spark plug can cause engine damage.*

1. Remove the engine cover (p. 48).
2. Disconnect the spark plug cap from the spark plug.
3. Remove the spark plug with a spark plug wrench and screwdriver supplied in the tool kit.
4. Inspect the spark plug. Replace it if the electrode is worn, or if the insulator is cracked or chipped.
5. Measure the spark plug electrode gap with a wire-type feeler gauge. Correct the gap, if necessary, by carefully bending the side electrode. The gap should be:  
0.024 – 0.028 in (0.60 – 0.70 mm)

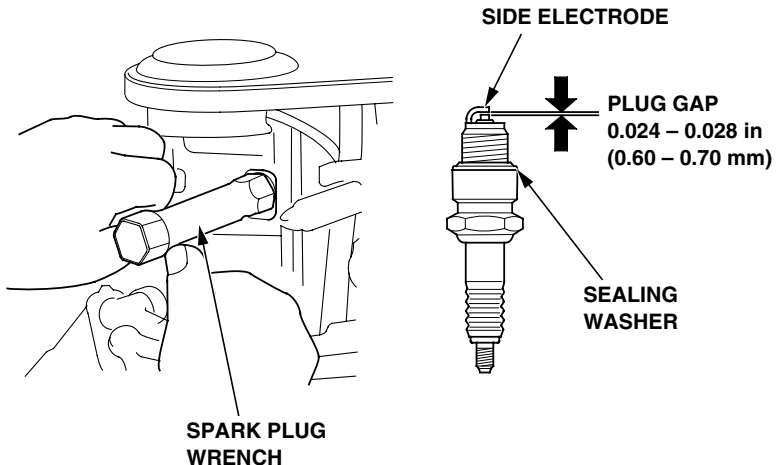



# SERVICING YOUR OUTBOARD MOTOR

---

6. Check that the spark plug washers are in good condition, and thread the spark plugs in by hand to prevent cross-threading.
7. After the spark plugs are seated, tighten with a spark plug wrench to compress the washers.

If reinstalling a used spark plugs, tighten 1/8–1/4 turn after the spark plug seats to compress the washers.

If installing a new spark plugs, tighten 1/2 turn after the spark plug seats to compress the washers.

## NOTICE

*Loose spark plugs can overheat and damage the engine.*

*Overtightening the spark plugs can damage the threads in the cylinder head.*

8. Attach the spark plug cap.
9. Install the engine cover.

## FUEL FILTER REPLACEMENT

The fuel filter is located between the fuel pump and the carburetor. Water or sediment accumulated in the fuel filter can cause loss of power or hard starting. To prevent engine malfunction, replace the fuel filter regularly.

## WARNING

Gasoline is highly flammable and explosive.

You can be burned or seriously injured when handling fuel.

- Stop the engine and keep heat, sparks and flame away.
- Handle fuel only outdoors.
- Wipe up spills immediately.

# SERVICING YOUR OUTBOARD MOTOR

---

1. Disconnect the fuel tank line from the motor.
2. Remove the engine cover, and remove the fuel filter. Before removing the filter, place commercially available hose clips on the fuel hoses on each side of the filter to prevent fuel leakage.
3. Install the new fuel filter with the arrow mark pointing toward the carburetor. Fuel flow will be impeded if the filter is installed backward.

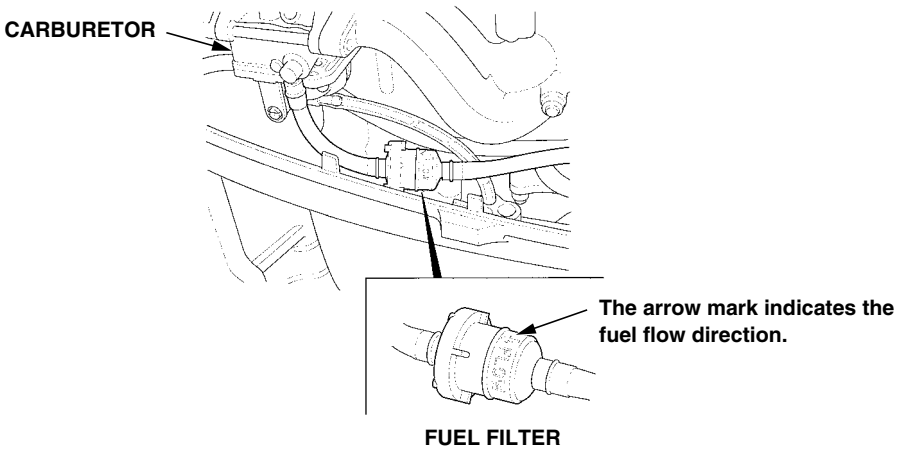

4. If loss of power or hard starting is found to be caused by excessive water or sediment accumulated in the fuel filter, inspect the fuel tank. Clean the fuel tank if necessary.
5. Remove the hose clips used to close the fuel hoses. Connect the fuel tank line to the motor. Turn the fuel tank vent knob counterclockwise to the open position, squeeze the priming bulb, and check for leaks.

# SERVICING YOUR OUTBOARD MOTOR

## RECOIL STARTER ROPE INSPECTION

Inspect the recoil starter rope, and replace it if it becomes frayed.

Always keep the tool kit's emergency starter rope on the boat in case the recoil starter rope fails.

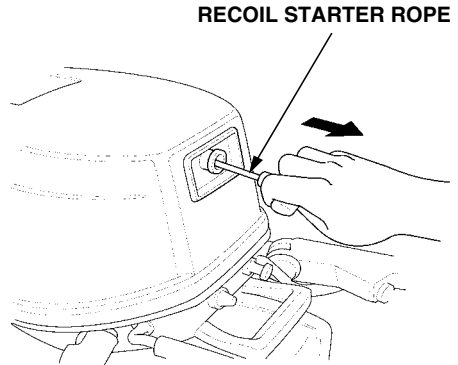

## ANODE REPLACEMENT

The anode is made of a sacrificial material that helps to protect the outboard motor from corrosion.

Replace the anode when it has been reduced to about half its original size, or if it is crumbling.

### NOTICE

*Painting or coating the anode will defeat its purpose and will lead to rust and corrosion damage to the outboard motor. The anode must be exposed to the water in order to protect the outboard motor.*

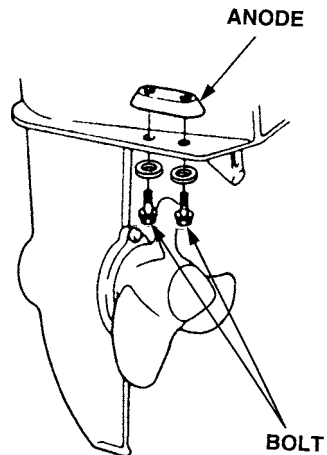

# SERVICING YOUR OUTBOARD MOTOR

## SHEAR PIN AND PROPELLER REPLACEMENT

A shear pin is used to protect the propeller and drive mechanism from damage when the propeller strikes an obstruction.

The propeller blades may have sharp edges, so wear heavy gloves to protect your hands.

1. Remove the cotter pin, the propeller cap, and the propeller.
2. Remove the broken shear pin and replace it with a new one.
3. Install the propeller, then install the propeller cap finger tight.
4. Install a new cotter pin, and spread the ends as shown in the illustration.

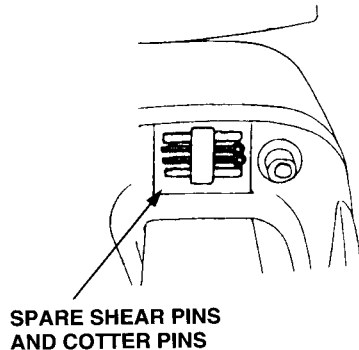
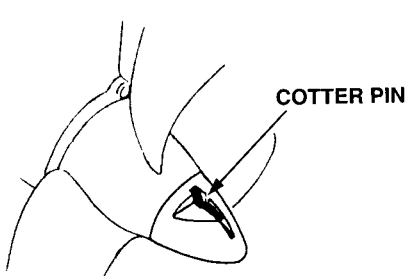
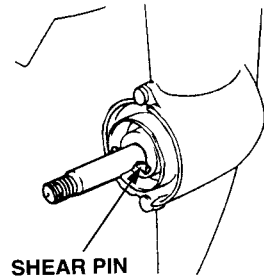
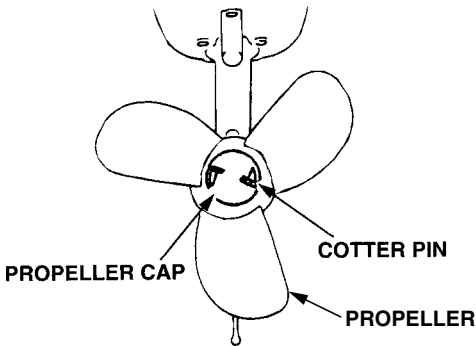

# SERVICING YOUR OUTBOARD MOTOR

## ENGINE COVER LOCK ADJUSTMENT

The engine cover should fit tightly to keep the engine compartment dry. If adjustment is needed, reposition the lock hook.

1. Remove the engine cover, and loosen the lock hook bolt with a 10 mm wrench.
2. Reposition the lock hook, and retighten the bolt. Be sure the lock washer serrations align with the hook serrations when tightening the bolt.
3. Install and lock the engine cover. Check whether the engine cover fits tightly. If necessary, repeat steps 1 and 2 to achieve a tight fit.

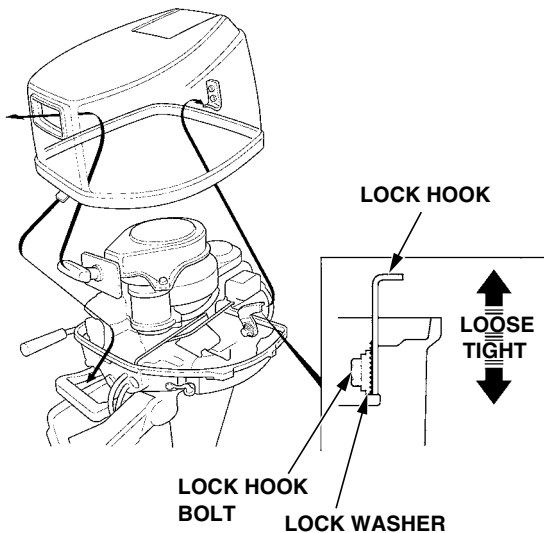

# HELPFUL TIPS AND SUGGESTIONS

## STORING YOUR OUTBOARD MOTOR

### Storage Preparation

Proper storage preparation is essential for keeping your outboard motor trouble-free and looking good. The following steps will help to keep rust and corrosion from impairing your outboard motor's function and appearance, and will make the engine easier to start when you use the outboard motor again.

### *Cleaning and Flushing*

Wash the outside of the outboard motor with clean, fresh water, and flush the cooling system as described on page 46 or 47.

Disengage the emergency engine stop switch clip from the engine stop switch, and pull the recoil starter rope several times to expel any water remaining in the water pump.

Touch up any damaged paint, and coat areas that may rust with Honda Corrosion Inhibitor, or equivalent. Lubricate controls with a silicone spray lubricant.

### *Fuel*

#### **NOTICE**

*Depending on the region where you operate your outboard, fuel formulations may deteriorate and oxidize rapidly. Fuel deterioration and oxidation can occur in as little as 15 days and may cause damage to the carburetors and fuel system. Please check with your servicing dealer for local storage recommendations.*

Gasoline will oxidize and deteriorate in storage. Old gasoline will cause hard starting, and it leaves gum deposits that clog the fuel system. If the gasoline in your fuel tank and carburetor deteriorates during storage, you may need to have the carburetor and other fuel system components serviced or replaced.

The length of time that gasoline can be left in your fuel tank and carburetor without causing functional problems will vary with such factors as gasoline blend, your storage temperatures, and whether the fuel tank is partially or completely filled. The air in a partially filled fuel tank promotes fuel deterioration. Very warm storage temperatures accelerate fuel deterioration. Fuel deterioration problems may occur in less than 30 days, if the gasoline was not fresh when you filled the fuel tank.

# HELPFUL TIPS AND SUGGESTIONS

The *Distributor's Limited Warranty* does not cover fuel system damage or engine performance problems resulting from neglected storage preparation.

You can extend fuel storage life by adding a gasoline stabilizer that is formulated for that purpose, or you can avoid fuel deterioration problems by draining all the fuel from the fuel tank and carburetor.

## ***Adding a Fuel Stabilizer***

When adding a fuel stabilizer, fill the fuel tank with fresh gasoline. If only partially filled, air in the tank will promote fuel deterioration during storage. If you keep a container of gasoline for refueling, be sure that it contains only fresh gasoline.

1. Add fuel stabilizer following the manufacturer's instructions.
2. After adding a fuel stabilizer, run the engine outdoors for 10 minutes to be sure that the treated gasoline has replaced the untreated gasoline in the carburetor.

Starting the engine on land:

For safety, remove the propeller from the outboard motor (p. 58).

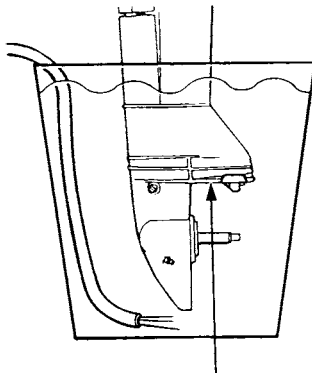

**ANTIVENTILATION PLATE**

- Place a container under the outboard motor, and fill it with clean, fresh water. The water level must be at least 6 inches above the antiventilation plate.

### **NOTICE**

*Running the engine without water can cause overheating and damage.*

Damage caused by running the outboard motor without water is not covered by the *Distributor's Limited Warranty*.

3. Turn the engine OFF.

# HELPFUL TIPS AND SUGGESTIONS

---

## *Draining the Fuel Tank and Carburetor*

You can avoid fuel deterioration problems by draining the fuel tank and carburetors.

1. Disconnect the fuel hose from the outboard motor.
2. With the outboard motor in a vertical position, place an approved gasoline container below the fuel drain outlet, and use a funnel to avoid spilling fuel. Loosen the drain screw to drain fuel from the carburetor.

### **⚠ WARNING**

Gasoline is highly flammable and explosive.

You can be burned or seriously injured when handling fuel.

- Stop the engine and keep heat, sparks, and flame away.
- Handle fuel only outdoors.
- Wipe up spills immediately.

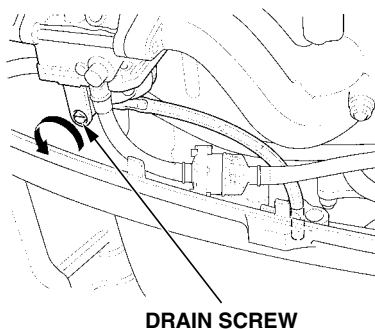

3. After the fuel has drained from the carburetor, tighten the drain screw securely.
4. Drain the fuel tank into an approved gasoline container, or if you need to store fuel in the portable fuel tank, you can extend fuel storage life by filling the fuel tank with fresh gasoline and adding a fuel stabilizer that is formulated for that purpose. Firmly close the fuel filler cap vent knob.

## *Engine Oil*

1. Change the engine oil (see page 49).
2. Remove the spark plugs (see page 54).
3. Pour a tablespoon (5 - 10 cm<sup>3</sup>) of clean engine oil into each cylinder.
4. Pull the starter grip several times to distribute the oil in the cylinders.
5. Reinstall the spark plugs.



# HELPFUL TIPS AND SUGGESTIONS

## Storage Precautions

Select a well-ventilated storage area. If possible, avoid storage areas with high humidity.

If your portable fuel tank contains gasoline, store it away from any appliance that operates with a flame, such as a furnace, water heater, or clothes dryer. Also avoid any area with a spark-producing electric motor, or where power tools are operated.

Store the outboard motor either vertically, or horizontally with the tiller handle side down, as shown.

If storing horizontally, be sure to fold the tiller handle, so the outboard motor rests on its case protectors. Be sure all water has drained from the outboard motor before placing it on its side, so no residual water can enter the engine exhaust port.

### NOTICE

*Any other storage position may cause damage or oil leakage.*

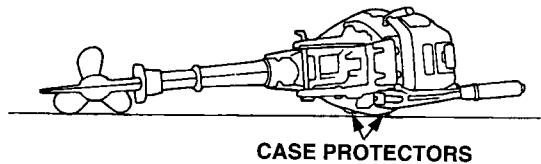
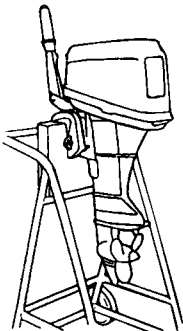

Cover the outboard motor to keep out dust. Do not use sheet plastic as a dust cover. A nonporous cover will trap moisture, promoting rust and corrosion.

# HELPFUL TIPS AND SUGGESTIONS

---

## Removal From Storage

Check your outboard motor as described in the *BEFORE OPERATION* chapter of this manual.

If the cylinder was coated with oil during storage preparation, the engine may smoke briefly at startup. This is normal.

## TRANSPORTING

### With outboard motor installed on boat

When trailering a boat with the outboard motor attached, leave the engine in the normal running position, if possible, and tighten the steering friction bolt securely (p. 36).

If there is insufficient road clearance in the normal running position, then tilt the outboard motor, leave the tilt lever in the tilt position, and use a motor support device, such as a transom-saver bar, or remove the outboard motor from the boat. Refer to the manufacture's instructions for using a motor support device.

### With outboard motor removed from boat

To transport the outboard motor when removed from the boat, secure it in either the vertical or horizontal position shown on page 63.

To carry, hold the outboard motor by the carrying handle, or hold by the carrying handle and the lug beneath engine cover lock lever as shown below.

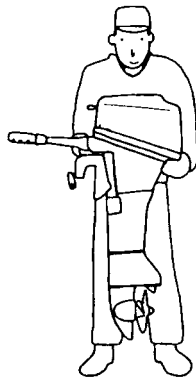

### NOTICE

*Lifting the outboard motor by the engine cover, or using the installed outboard motor as a handle or lever to move the boat, can damage the outboard motor.*

# TAKING CARE OF UNEXPECTED PROBLEMS

## ENGINE WILL NOT START

1. Is the emergency stop switch clip in place?
2. Is the gearshift lever in neutral?
3. Is there fuel in the fuel tank?
4. Is the fuel cap vent knob turned to open?
5. Is the fuel system primed by squeezing the priming bulb?
6. Is fuel reaching the carburetor?

Loosen the carburetor drain screw to see if there is fuel in the carburetor float bowl.

### **WARNING**

If any fuel is spilled, make sure the area is dry before starting the engine. Spilled fuel or fuel vapor may ignite.

7. Is the spark plug in good condition?

Remove and inspect the spark plug. Readjust gap and dry the spark plug. Replace it if necessary.

## **Engine overheats:**

1. Is the water inlet screen clogged?
2. Is the thermostat faulty?

# TAKING CARE OF UNEXPECTED PROBLEMS

---

## BATTERY DOES NOT CHARGE

The battery-charging circuit is protected by a 5-ampere fuse.

If the fuse burns out, running the engine will not charge the battery.

### Fuse Replacement

1. With the engine stopped, remove the engine cover.
2. Pull the rubber cover off the end of the fuse holder, and unscrew the fuse holder cap.
3. Remove and inspect the fuse. If the fuse is burnt out, install a replacement 5-ampere fuse.

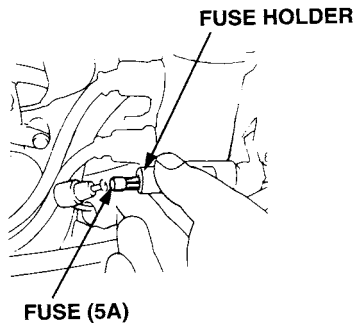

#### NOTICE

*Never use a fuse with a rating greater than 5-amperes. Serious damage to the electrical system could result.*

4. Reinstall the fuse holder and engine cover.

Before further operation, try to determine and correct the electrical problem that caused the fuse to burn out. An uncorrected electrical problem may cause the fuse to burn out again.

# TAKING CARE OF UNEXPECTED PROBLEMS

## SUBMERGED MOTOR

A submerged motor must be serviced immediately after it is recovered from the water in order to minimize corrosion.

If there is a Honda marine dealer nearby, take the motor to the dealer immediately. If you are far from a dealer, proceed as follows:

1. Remove the engine cover, and rinse the outboard motor with fresh water to remove salt water, sand, mud, etc.
2. Loosen the carburetor drain screw (p. 62), drain the contents of the carburetor into a suitable container, then tighten the drain screw.
3. Change the engine oil (p. 49). If there was water in the engine crankcase, or if the used engine oil showed signs of water contamination, then a second engine oil change should be performed after running the engine for 1/2 hour.
4. Remove the spark plugs (p. 54). Disengage the emergency engine stop switch clip from the engine stop switch and pull the starter grip, rotate the flywheel a few revolutions to completely expel water from the cylinders.

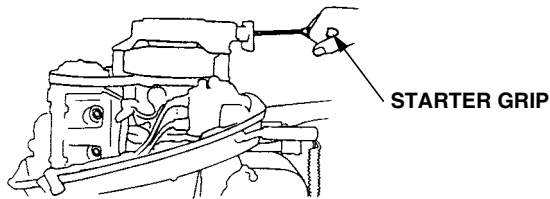

### NOTICE

- *When cranking the engine with an open ignition circuit (spark plugs removed from the ignition circuit), disengage the emergency engine stop switch clip from the engine stop switch to prevent electrical damage to the ignition system.*
- *If the engine was running when it submerged, there may be mechanical damage, such as bent connecting rods. If the engine binds when cranked, do not attempt to run the engine until it has been repaired.*

## TAKING CARE OF UNEXPECTED PROBLEMS

---

5. Pour a teaspoon of engine oil into the spark plug hole, then pull the starter grip several times to lubricate the inside of the cylinders. Reinstall the spark plug and engage the emergency engine stop switch clip with the engine stop switch.

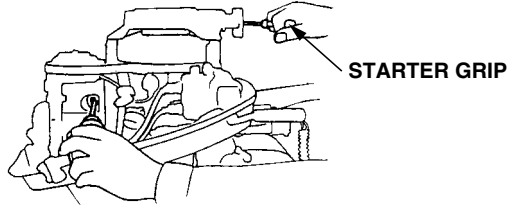

6. Attempt to start the engine.
  - If the engine fails to start, remove the spark plug, clean and dry the electrode, then reinstall the spark plug and attempt to start the engine again.
  - If the engine starts, and no mechanical damage is evident, continue to run the engine for 1/2 hour or longer (be sure the water level is at least 2 inches above the antivibration plate).
7. As soon as possible, take the motor to an authorized Honda marine dealer for inspection and service.

# TECHNICAL AND CONSUMER INFORMATION

## TECHNICAL INFORMATION

### Serial Number Locations

**ENGINE SERIAL NUMBER**

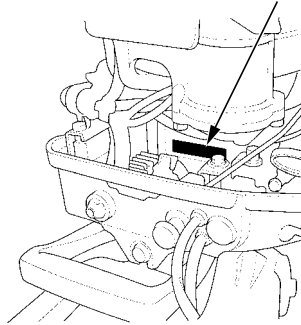

**PRODUCT IDENTIFICATION NUMBER**

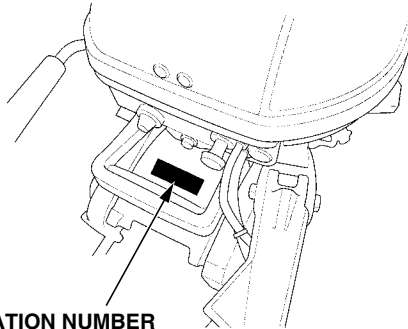

Record the engine serial number, the product identification number and the date of purchase in the space below. You will need these serial numbers when ordering parts, and when making technical or warranty inquiries (see page 78).

Engine serial number: \_\_\_\_\_

Product identification number: \_\_\_\_\_

Date of purchase: \_\_\_\_\_

# TECHNICAL AND CONSUMER INFORMATION

---

## Carburetor Modification for High Altitude Operation

At high altitude, the standard carburetor air-fuel mixture will be too rich. Performance will decrease, and fuel consumption will increase. A very rich mixture will also foul the spark plug and cause hard starting.

High altitude performance can be improved by specific modifications to the carburetor. If you always operate your outboard motor at altitudes above 5,000 feet (1,500 meters), have an authorized Honda marine dealer perform this carburetor modification.

Even with carburetor modification, engine horsepower will decrease about 3.5 % for each 1,000-foot (300-meter) increase in altitude. The effect of altitude on horsepower will be greater than this if no carburetor modification is made.

### **NOTICE**

*When the carburetor has been modified for high altitude operation, the air-fuel mixture will be too lean for low altitude use. Operation at altitudes below 5,000 feet (1,500 meters) with modified carburetor may cause the engine to overheat and result in serious engine damage. For use at low altitudes, have an authorized Honda Marine dealer return the carburetor to original factory specifications.*



# TECHNICAL AND CONSUMER INFORMATION

---

## Oxygenated Fuels

Some conventional gasolines are being blended with alcohol or an ether compound. These gasolines are collectively referred to as oxygenated fuels. To meet clean air standards, some areas of the United States and Canada use oxygenated fuels to help reduce emissions.

If you use an oxygenated fuel, be sure it is unleaded and meets the minimum octane rating requirement.

Before using an oxygenated fuel, try to confirm the fuel's contents. Some states/provinces require this information to be posted on the pump.

The following are the EPA-approved percentages of oxygenates:

**ETHANOL** — (ethyl or grain alcohol) 10% by volume.  
You may use gasoline containing up to 10% ethanol by volume. Gasoline containing ethanol may be marketed under the name "Gasohol".

**MTBE** — (Methyl Tertiary Butyl Ether) 15% by volume.  
You may use gasoline containing up to 15% MTBE by volume.

**METHANOL** — (methyl or wood alcohol) 5% by volume.  
You may use gasoline containing up to 5% methanol by volume, as long as it also contains cosolvents and corrosion inhibitors to protect the fuel system. Gasoline containing more than 5% methanol by volume may cause starting and/or performance problems. It may also damage metal, rubber, and plastic parts of your fuel system.

If you notice any undesirable operating symptoms, try another service station, or switch to another brand of gasoline.

Fuel system damage or performance problems resulting from the use of an oxygenated fuel containing more than the percentages of oxygenates mentioned above are not covered under warranty.

# **TECHNICAL AND CONSUMER INFORMATION**

---

## **Emission Control System Information**

### ***Source of Emissions***

The combustion process produces carbon monoxide, oxides of nitrogen, and hydrocarbons. Control of hydrocarbons and oxides of nitrogen is very important because, under certain conditions, they react to form photochemical smog when subjected to sunlight. Carbon monoxide does not react in the same way, but it is toxic.

Honda utilizes lean carburetor settings and other systems to reduce the emissions of carbon monoxide, oxides of nitrogen, and hydrocarbons.

### ***The U.S. and California Clean Air Acts***

EPA and California regulations require all manufacturers to furnish written instructions describing the operation and maintenance of emission control systems.

The following instructions and procedures must be followed in order to keep the emissions from your Honda engine within the emission standards.

### ***Tampering and Altering***

Tampering with or altering the emission control system may increase emissions beyond the legal limit. Among those acts that constitute tampering are:

- Removal or alteration of any part of the intake, fuel, or exhaust systems.
- Alterations that would cause the engine to operate outside its design parameters.

## ***Problems That May Affect Emissions***

If you are aware of any of the following symptoms, have your engine inspected and repaired by your servicing dealer.

- Hard starting or stalling after starting.
- Rough idle
- Misfiring or backfiring under load.
- Afterburning (backfiring).
- Black exhaust smoke or high fuel consumption.

## ***Replacement Parts***

The emission control systems on your Honda engine were designed, built, and certified to conform with EPA and California emission regulations. We recommend the use of genuine Honda parts whenever you have maintenance done. These original-design replacement parts are manufactured to the same standards as the original parts, so you can be confident of their performance. The use of replacement parts that are not of the original design and quality may impair the effectiveness of your emission control system.

A manufacturer of an aftermarket part assumes the responsibility that the part will not adversely affect emission performance. The manufacturer or rebuilder of the part must certify that use of the part will not result in a failure of the engine to comply with emission regulations.

## ***Maintenance***

Follow the maintenance schedule on page 43. Remember that this schedule is based on the assumption that your machine will be used for its designed purpose. Sustained high-load operation, or use in unusual conditions, will require more frequent service.

# TECHNICAL AND CONSUMER INFORMATION

---

## Star Label

A Star label was applied to this outboard motor in accordance with the requirements of the California Air Resources Board.

### *The Star Label means Cleaner Marine Engine*

This engine has been certified as a:

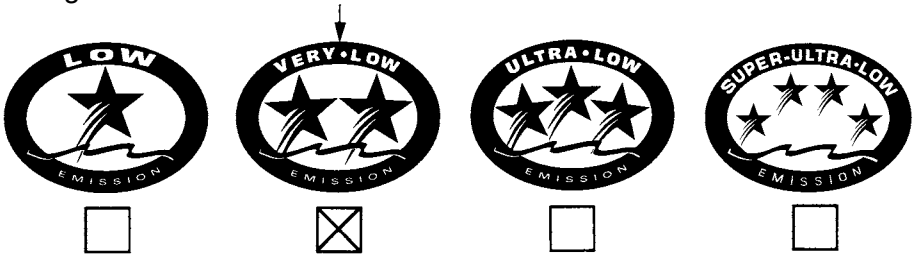

### The Symbol for Cleaner Marine Engines:

**Cleaner Air and Water** - for healthier lifestyle and environment.

**Better Fuel Economy** - burns up to 30 - 40 percent less gas and oil than conventional carbureted two-stroke engines, saving money and resources.

**Longer Emission Warranty** - protects consumer for worry-free operation.



### **One Star Low Emission**

The one-star label identifies engines that meet the Air Resources Board's Personal Watercraft and Outboard marine engine 2001 exhaust emission standards. Engines meeting these standards have 75% lower emissions than conventional carbureted two-stroke engines. These engines are equivalent to the U.S. EPA's 2006 standards for marine engines.

# TECHNICAL AND CONSUMER INFORMATION

---



## **Two Stars Very Low Emission**

The two-star label identifies engines that meet the Air Resources Board's Personal Watercraft and Outboard marine engine 2004 exhaust emission standards. Engines meeting these standards have 20% lower emissions than One Star-Low Emission engines.



## **Three Stars Ultra Low Emission**

The three-star label identifies engines that meet the Air Resources Board's Personal Watercraft and Outboard marine engine 2008 exhaust emission standards or the Sterndrive and Inboard marine engine 2003 – 2008 exhaust emission standards. Engines meeting these standards have 65% lower emissions than One Star-Low Emission engines.



## **Four Stars Super Ultra Low Emission**

The four-star label identifies engines that meet the Air Resources Board's Sterndrive and Inboard marine engine 2009 exhaust emission standards. Personal Watercraft and Outboard marine engines may also comply with these standards. Engines meeting these standards have 90% lower emissions than One Star-Low Emission engines.

Cleaner Watercraft - Get the Facts  
1-800-END-SMOG  
[www.arb.ca.gov](http://www.arb.ca.gov)

# TECHNICAL AND CONSUMER INFORMATION

## Specifications

| Model  |        | BF8A   |                             |
|--|--------|--|-----------------------------|
| Description code                                       |        | BZBC   |                             |
| Rated power  |        | 6.3 kW (8.4 HP)  |                             |
| Full throttle range                                    |        | 4,950 — 5,500 rpm  |                             |
| Engine type  |        | 4-stroke OHC in-line twin cylinder   |                             |
| Displacement   |        | 12.0 cu-in (197 cm <sup>3</sup> )  |                             |
| Spark plug gap   |        | 0.024 — 0.028 in (0.60 — 0.70 mm)  |                             |
| Starter system   |        | Recoil starter   |                             |
| Ignition system  |        | Digital Ignition Control Module (ICM)  |                             |
| Lubrication system                                     |        | Trochoid pump pressure lubrication   |                             |
| Specified oil  |        | Engine: API standard (SG or later oil)<br>SAE 10W-30<br>Gear case: API standard (GL-4/5)<br>SAE 90 outboard motor gear oil |                             |
| Oil capacity   |        | Engine: 0.85 US qt (0.80 ℓ, 0.70 Imp qt)<br>Gear case: 0.24 US qt (0.23 ℓ, 0.20 Imp qt)                                    |                             |
| CARB star label  |        | VERY•LOW EMISSION  |                             |
| D.C. output  |        | 12V—5A   |                             |
| Cooling system   |        | Water cooling with thermostat (volumetric pump)  |                             |
| Exhaust system   |        | Underwater exhaust   |                             |
| Spark plugs  |        | DR-5HS (NGK)   |                             |
| Fuel pump  |        | Diaphragm type fuel pump   |                             |
| Fuel   |        | Automotive unleaded gasoline (86 pump octane or higher)  |                             |
| Tank capacity  |        | 3.0 US gal (12 ℓ, 2.6 Imp gal)   |                             |
| Steering equipment                                     |        | Tiller handle  |                             |
| Tilt angle   |        | 3-stage adjustment (30°, 45° and 70°)  |                             |
| Steering angle   |        | 40° right and left   |                             |
| Dimensions   |        | S Model  | L Model                     |
|  | Length | 20.7 in (525 mm)   | 20.7 in (525 mm)            |
|  | Height | 39.8 in (1,010 mm)   | 45.7 in (1,160 mm)          |
|  | Width  | 12.4 in (315 mm)   | 12.4 in (315 mm)            |
| Outboard motor transom height                          |        | S Model<br>16.5 in (420 mm)  | L Model<br>22.5 in (572 mm) |
| Standard propeller<br>(No. of blades-diameter x pitch) |        | 9-1/2 x 8-5/8 in (3-240 x 220 mm)  |                             |
| Gear change  |        | Forward-Neutral-Reverse (dog type)   |                             |
| Dry weight   |        | S Model 77.2 lbs. (35.0 kg)  | L Model 79.4 lbs. (36.0 kg) |

Honda outboards are power rated in accordance with NMMA procedures and using the ICOMIA standard 28/23.

# TECHNICAL AND CONSUMER INFORMATION

---

## Tuneup

|                        |   |                  |
|------------------------|---|------------------|
| Spark plug gap         | 0.024-0.028 in (0.60-0.70 mm)                             | See page 54.     |
| Idle speed             | 1,200 $\pm$ 100   | See shop manual. |
| Valve clearance (cold) | Intake: 0.12 $\pm$ 0.02 mm<br>Exhaust: 0.20 $\pm$ 0.02 mm | See shop manual. |
| Other specifications   | No other adjustments needed.                              |                  |

# TECHNICAL AND CONSUMER INFORMATION

---

## CONSUMER INFORMATION

### **Honda Publications**

These publications will give you additional information for maintaining and repairing your outboard motor.

#### ***Shop Manual***

This manual covers complete maintenance and overhaul procedures. It is intended to be used by a skilled technician.

Available through your Honda marine dealer or through Helm Inc. at 1 888-292-5395 or visit [www.Honda-marine.com](http://www.Honda-marine.com) > product manuals.

#### ***Parts Catalog***

This manual provides complete, illustrated parts lists. The catalog is available from your Honda marine dealer.



# TECHNICAL AND CONSUMER INFORMATION

---

## Customer Service Information

### *Contacting Honda*

Your owner's manual was written to cover most of the questions you might ask about your Honda. Any questions not answered in the owner's manual can be answered by your Honda dealer. If your dealer doesn't have an immediate answer, they should be able to get it for you.

If you have a difference of opinion with your dealer, please remember that each dealership is independently owned and operated. That's why it's important to work to resolve any differences at the dealership level. If the service personnel are unable to assist you, please discuss your concerns with the dealer management such as the Service Manager or Dealer Owner.

If you need to contact American Honda regarding your experiences with your Honda product or with your dealer, please send your comments to the following address:

American Honda Motor Co., Inc.  
Marine Division  
Customer Relations Office  
4900 Marconi Drive  
Alpharetta, GA 30005-8847  
Telephone (770) 497-6400  
M-F 8:30 am — 7:00 pm (Eastern Time Zone)

## **TECHNICAL AND CONSUMER INFORMATION**

---

Please include the following information in your communication:

- Your name, address and telephone number (complete with area code)
- Model and complete serial number
- Date of purchase
- Name and location of selling dealer
- Name and location of servicing dealer (if different)
- A detailed description of your concerns

We will likely ask your Honda dealer to respond, or possibly acknowledge your comments directly.

## ***Warranty Coverage***

Your new Honda is covered by the following warranties:

- Distributor's Limited Warranty
- Emission Control Warranty

Please read the warranty statements contained in this manual. There are responsibilities, restrictions, and exclusions that apply to these warranties.

To obtain warranty service you must take your Honda outboard engine, together with proof of original retail purchase date, at your expense, to a Honda engine dealer or distributor authorized to sell that product in the United States, Puerto Rico, or the U. S. Virgin Islands.

It is important to realize that your warranty applies to defects in material or workmanship of your Honda. Your warranty coverage does not apply to normal wear or deterioration associated with using your Honda outboard.

Your warranty coverage will not be voided if you choose to perform your own maintenance. However, you should have the proper tools and service information and be mechanically qualified. Failures that occur due to modifications, improper maintenance or service are not covered.

# TECHNICAL AND CONSUMER INFORMATION

---

## *Warranty Service*

Please remember that recommended maintenance interval servicing is not included in your warranty coverage. Additionally, your warranty does not apply to the normal wear of items (such as spark plug(s), water pump, etc.).

As the owner of a Honda product, your servicing dealer may ask you to authorize an inspection. If the problem is covered under warranty, your dealer will perform any warranty repairs for you at no cost. However, you may be responsible for additional non-warranty charges.

If you have questions about warranty coverage or the nature of the repair, it is best to talk to the service manager of your Honda dealer.

Sometime, in spite of the best intentions of all concerned, a misunderstanding may occur. If you aren't satisfied with your dealer's handling of the situation, we suggest you discuss your problem with the appropriate member of the dealership's management team. If the problem has already been reviewed with the appropriate manager of the Service, Parts, or Sales department, contact the owner of the dealership or their designated representative.

# TECHNICAL AND CONSUMER INFORMATION

## Distributor's Limited Warranty

This warranty is limited to Honda Outboard Motors distributed by American Honda Motor Co., Inc., Power Equipment Division, 4900 Marconi Drive, Alpharetta, Georgia 30005-8847.

| Products Covered by Warranty:                   | Length of Warranty: (from date of original retail purchase) |                       |                                    |
|---|---|-----------------------|------------------------------------|
|   | NONCOMMERCIAL/<br>NONRENTAL                                 | COMMERCIAL/<br>RENTAL | STATE/LOCAL/<br>FEDERAL GOVERNMENT |
| All Models: Model Year 2000 (Y) and Newer       | 36 months   | 12 months             | 24 months                          |
| Models BF115/BF130: All Model Years             | 36 months   | 12 months             | 24 months                          |
| Models BF2 – BF90 – Model Year 1999 and Earlier | 24 months   | 12 months             | 24 months                          |

### To Qualify for This Warranty:

The Honda Outboard Motor must be purchased from American Honda or a dealer authorized by American Honda to sell Honda Outboard Motors in the United States, Puerto Rico, or the U.S. Virgin Islands. This limited warranty applies to the first retail purchaser and each subsequent owner during the applicable warranty time period.

### What American Honda Will Repair or Replace Under Warranty:

American Honda will repair or replace, at its option, any part that is proven to be defective in material or workmanship under normal use during the applicable warranty time period. Warranty repairs and replacements will be made without charge for parts or labor. Anything replaced under warranty becomes the property of American Honda Motor Company, Inc. All parts replaced under warranty will be considered as part of the original product and any warranty on those parts will expire coincidentally with the original product warranty.

### To Obtain Warranty Service:

You must take your Honda Outboard Motor and proof of the original purchase date, at your expense, to any dealer who is authorized to service Honda Outboard Motors in the United States, Puerto Rico, or the U.S. Virgin Islands, during the dealer's normal business hours. If you are unable to obtain warranty service, or are dissatisfied with the warranty service you receive, take the following steps: First, contact the owner of the dealership involved; normally this should resolve the problem. However, if you should require further assistance, write or call the Honda Marine Customer Relations. Please see *Contacting Honda* page 79.

# TECHNICAL AND CONSUMER INFORMATION

---

## **Exclusions:**

This warranty does not extend to the following:

- Conditions caused by lack of routine maintenance (as outlined in the owner's manual)
- Conditions caused by the use of propeller (s) that do not allow the outboard motor to run in its recommended full throttle rpm range
- Operation inconsistent with the recommended operation/duty cycle (as outlined in the owner's manual)
- Parts affected or damaged by an accident, submersion and/or collision
- Normal wear and tear
- Fuel contamination and water entering engine through the fuel intake, air intake or exhaust system
- Operation with fuels, oils, additives and lubricants which are not suitable for use in the product
- Use in an application for which the outboard motor was not designed, such as racing or competitive use or any other misuse or neglect
- Incorporation of unsuitable attachments or parts
- The unauthorized alteration, improper installation and/or rigging, or any causes other than defects in material or workmanship
- Corrosion to steering system or electrical components, corrosion due to electrolysis, water born foreign chemicals, improper service or corrosion caused by damage or abuse
- Reimbursement for towing charges, in and out of water charges, or technician travel time
- Growth of marine organisms on motor surfaces, external or internal

## **Disclaimer of consequential damage and limitation of implied warranties:**

American Honda disclaims any responsibility for loss of time or use of the outboard, revenue, or the equipment in which the outboard is installed, transportation, commercial loss, or any other incidental or consequential damage. Any implied warranties are limited to the duration of this written limited warranty. Some states do not allow limitations on how long an implied warranty lasts and/or do not allow the exclusion or limitation of incidental or consequential damages, so the above exclusions and limitations may not apply to you. This warranty gives you specific legal rights, and you may also have other rights which vary from state to state.

# TECHNICAL AND CONSUMER INFORMATION

## Accessories and Replacement Parts

This warranty is limited to Honda Power Equipment parts, accessories and apparel when distributed by American Honda Motor Co., Inc., 1919 Torrance Blvd., Torrance, California 90501-2746

| Products Covered by Warranty: | Length of Warranty: (from date of original retail purchase) |                       |                                    |
|-------------------------------|---|-----------------------|------------------------------------|
|                               | Non Commercial  | Commercial/<br>Rental | Local/State/<br>Federal Government |
| Accessories                   | 12 months   | 3 months              | 3 months                           |
| Replacement Parts             | 6 months  | 3 months              | 3 months                           |

### To Qualify for This Warranty:

1. The accessories or replacement parts must be purchased from American Honda, or a dealer, distributor or distributor's dealer authorized by American Honda to sell those products in the United States, Puerto Rico, and the U.S. Virgin Islands.
2. You must be the first retail purchaser. This warranty is not transferable to subsequent owners.

### What American Honda Will Repair or Replace Under Warranty:

American Honda will repair or replace, at its option, any marine product accessories or replacement parts that are proven to be defective in material or workmanship under normal use during the applicable warranty time period. Anything replaced under warranty becomes the property of American Honda Motor Company, Inc. All parts replaced under warranty will be considered as part of the original product and any warranty on those parts will expire coincidentally with the original product warranty. Accessories and replacement parts, installed by a dealer who is authorized by American Honda to sell them, will be repaired or replaced under warranty without charge for parts or labor. If installed by anyone else, accessories and replacement parts will be repaired or replaced under warranty without charge for parts, but any labor charges will be the responsibility of the purchaser.

### To Obtain Warranty Service:

You must take the Honda Outboard Motor product accessory or replacement part or the outboard motor or boat on which the accessory or replacement part is installed, and proof of purchase, at your expense, to any Honda Marine authorized service facility or dealer in the United States, Puerto Rico, or the U.S. Virgin Islands, during normal business hours.

### Exclusions:

This warranty does not extend to accessories or parts affected or damaged by accident and/or collision, normal wear, use in an application for which the product was not designed or any other misuse, neglect, incorporation or use of unsuitable attachments or parts, unauthorized alteration, improper installation, or any causes other than defects in material or workmanship of the product.

### Disclaimer of consequential damage and limitation of implied warranties:

American Honda disclaims any responsibility for loss of time or use of the outboard motor, or the boat on which the product is installed, transportation, commercial loss, or any other incidental or consequential damage. Any implied warranties are limited to the duration of this written warranty. Some states do not allow limitations on how long an implied warranty lasts and/or do not allow the exclusion or limitation of incidental or consequential damages, so the above exclusions and limitations may not apply to you. This warranty gives you specific legal rights, and you may also have other rights which vary from state to state.

# TECHNICAL AND CONSUMER INFORMATION

---

## Emission Control System Warranty

Your new Honda outboard engine complies with both the U.S. EPA and State of California emission regulations. American Honda provides the same emission warranty coverage for outboard engines sold in all 50 states.

### YOUR WARRANTY RIGHTS AND OBLIGATION

#### California

The California Air Resources Board and American Honda Motor Co., Inc. are pleased to explain the emission control system warranty on your 2001 and later Honda outboard engine. In California, new outboard engines must be designed, built and equipped to meet California's stringent anti-smog emission standards in addition to the U.S. EPA emissions standards.

#### Other States

In other areas of the United States your outboard engine must be designed, built and equipped to meet the U.S. EPA Emission Standard for spark ignited marine engines.

#### All States

American Honda Motor Co., Inc. must warranty the emission control system on your outboard engine for the period of time listed below provided there has been no abuse, neglect or improper maintenance of your outboard engine. Where a warranty condition exists, American Honda Motor Co., Inc. will repair your outboard engine at no cost to you including diagnosis, parts and labor. Your emission control system may include such parts as the carburetor or fuel injection system and catalytic converter. Also included may be hoses, connectors and other emission-related assemblies.

### MANUFACTURER'S EMISSION CONTROL SYSTEM WARRANTY COVERAGE:

The 2001 and later outboard engines are warranted for four years or 250 hours of operation, whichever comes first. However, warranty coverage based on the hourly period is only permitted for outboard engines equipped with appropriate hour meters. If any emission-related part on your outboard engine is defective under warranty, the part will be repaired or replaced by American Honda Motor Co., Inc.

### OWNER'S WARRANTY RESPONSIBILITY:

As the outboard engine owner, you are responsible for the performance of the required maintenance listed in your owner's manual. American Honda Motor Co., Inc. recommends that you retain all receipts covering maintenance on your outboard engine, but American Honda Motor Co., Inc. cannot deny warranty solely for the lack of receipts or for your failure to ensure the performance of all scheduled maintenance. As the outboard engine owner, you should, however, be aware that American Honda Motor Co., Inc. may deny you warranty coverage if your outboard engine or a part has failed due to abuse, neglect, improper maintenance, or unapproved modifications. You are responsible for presenting your outboard engine to a Honda Marine dealer as soon as a problem exists. The warranty repair should be completed in a reasonable amount of time, not to exceed 30 days. If you have any questions regarding your warranty rights and responsibilities, you should contact American Honda Motor Co., Inc. Marine Division Customer Relations Office. Please see *Contacting Honda* page 79.

### WARRANTY COVERAGE:

Honda outboard engines manufactured after June 1, 2000 are covered by this warranty for a period of four years or 250 operating hours, whichever comes first, from the date of delivery to the retail purchaser. This warranty is transferred to each subsequent purchaser for the duration of the warranty period. Warranty repairs will be made without charge for diagnosis, parts and labor. All defective parts replaced under this warranty become the property of American Honda Motor Co., Inc. A list of warranty parts is on page 87. Normal maintenance items, such as spark plugs and filters, that are on the warranted parts list are warranted up to their required replacement interval only. American Honda Motor Co., Inc. is also liable for damages to other engine components caused by a failure of any warranted part during the warranty period. Only Honda approved replacement parts will be used in the performance of any warranty repairs and they will be provided without charge to the owner. The use of replacement parts not equivalent to the original parts may impair the effectiveness of your engine's emission control system. If such a replacement part is used in the repair or maintenance of your engine, and an authorized Honda Marine dealer determines it is defective or causes a failure of a warranted part, your claim for your engine may be denied. If the part in question is not related to the reason that your engine requires repair, your claim will not be denied.

### TO OBTAIN WARRANTY SERVICE:

You must take your Honda outboard engine, along with your sales registration card or other proof of original purchase date, at your expense, to any Honda Marine dealer who is authorized by American Honda Motor Co., Inc. to sell and service that Honda marine product during his normal business hours. Claims for repair or adjustment found to be caused solely by defects in material or workmanship will not be denied because the engine was not properly maintained and used. If you are unable to obtain warranty service, or are dissatisfied with the warranty service you received, contact the owner of the dealership involved. Normally this should resolve your problem. However, if you require further assistance, write or call the Honda Marine Customer Relations Office of American Honda Motor Co., Inc.



# TECHNICAL AND CONSUMER INFORMATION

## EXCLUSIONS:

FAILURES OTHER THAN THOSE RESULTING FROM DEFECTS IN MATERIAL OR WORKMANSHIP ARE NOT COVERED BY THIS WARRANTY. THIS WARRANTY DOES NOT EXTEND TO EMISSION CONTROL SYSTEMS OR PARTS WHICH ARE AFFECTED OR DAMAGED BY OWNER ABUSE, NEGLIGENCE, IMPROPER MAINTENANCE, MISUSE, MISFUELING, IMPROPER STORAGE, ACCIDENT AND/OR COLLISION. THE INCORPORATION OF, OR USE OF, UNSUITABLE ATTACHMENTS, OR THE UNAUTHORIZED ALTERATION OF ANY PART. THIS WARRANTY DOES NOT COVER REPLACEMENT OF EXPENDABLE MAINTENANCE ITEMS MADE IN CONNECTION WITH REQUIRED MAINTENANCE SERVICE AFTER THE ITEM'S FIRST SCHEDULED REPLACEMENT AS LISTED IN THE MAINTENANCE SECTION OF THE PRODUCT OWNER'S MANUAL, SUCH AS: SPARK PLUGS AND FILTERS.

## DISCLAIMER OF CONSEQUENTIAL DAMAGE AND LIMITATION OF IMPLIED WARRANTIES:

American Honda Motor Co., Inc. disclaims any responsibility for incidental or consequential damages such as loss of time or the use of outboard engine, or any commercial loss due to the failure of the equipment; and any implied warranties are limited to the duration of this written warranty. This warranty is applicable only where the California or U.S. EPA emission control system warranty regulation is in effect.

## EMISSION CONTROL SYSTEM WARRANTY PARTS:

| SYSTEMS COVERED BY THIS WARRANTY: | PARTS DESCRIPTION  |
|-----------------------------------|--|
| Fuel Metering                     | Carburetor assembly, Throttle body, Fuel injector, Fuel pump, Fuel pressure regulator, Throttle position sensor, Intake air temperature sensor, Engine temperature sensor, Manifold absolute pressure sensor, Idle air control valve, Barometric pressure sensor, Fuel line solenoid valve, Intake manifold, Intake valves, and Oxygen sensor or Air fuel ratio sensor |
| Air Induction                     | Air intake duct, Crankcase breather tube, Positive crankcase ventilation valve, Vapor separator, Intake manifold tuning valve (Intake air bypass control valve)  |
| Ignition                          | Flywheel magneto, Ignition pulse generator, Ignition coil assembly, Ignition control module, Engine control module, Crankshaft position sensor, Spark plug cap, Spark plug*, Knock sensor, and Camshaft position sensor  |
| Lubrication system                | Oil pump and internal parts  |
| Crankcase Emission Control        | Oil filler cap   |
| Exhaust                           | Exhaust manifold and Exhaust valves  |
| Valve Control System              | Rocker arm oil control valve   |
| Miscellaneous Parts               | Tubing, fittings, seals, gaskets, and clamps associated with these listed systems.   |

\* Covered up to the first required replacement only. See the Maintenance Schedule in the owner's manual.



## A

|                                       |    |
|---------------------------------------|----|
| ANODE REPLACEMENT .....               | 57 |
| ARE YOU READY TO GET UNDER WAY? ..... | 25 |
| Anode .....                           | 18 |

## B

|                          |    |
|--------------------------|----|
| BATTERY .....            | 22 |
| DOES NOT CHARGE .....    | 66 |
| Connections .....        | 22 |
| Installation .....       | 23 |
| BEFORE OPERATION .....   | 25 |
| BREAK-IN PROCEDURE ..... | 27 |

## C

|   |    |
|---|----|
| Carbon Monoxide Hazard .....                              | 8  |
| Carburetor Modification for High Altitude Operation ..... | 70 |
| Choke Knob .....  | 12 |
| Cleaning and Flushing Without the Flush Kit .....         | 47 |
| Cleaning and Flushing with the Optional Flush Kit .....   | 46 |
| COMPONENT AND CONTROL LOCATIONS .....                     | 10 |
| Connections to the Battery .....                          | 24 |
| CONSUMER INFORMATION .....                                | 78 |
| CONTROL AND FEATURES .....                                | 10 |
| CONTROLS .....  | 12 |
| COOLING SYSTEM CLEANING AND FLUSHING .....                | 46 |
| Cooling System Indicator .....                            | 17 |
| CRUISING .....  | 37 |
| Customer Service Information .....                        | 79 |

## D

|                                      |    |
|--------------------------------------|----|
| Distributor's Limited Warranty ..... | 83 |
|--------------------------------------|----|

# INDEX

---

## E

### EMERGENCY

|                       |    |
|-----------------------|----|
| Engine Stopping ..... | 34 |
| PROCEDURES .....      | 23 |
| STARTING .....        | 33 |

### ENGINE

#### COVER

|                       |    |
|-----------------------|----|
| LOCK ADJUSTMENT ..... | 59 |
| Lock Lever .....      | 16 |

#### OIL

|                       |    |
|-----------------------|----|
| CHANGE .....          | 49 |
| LEVEL CHECK .....     | 48 |
| RECOMMENDATIONS ..... | 50 |

|                                   |    |
|-----------------------------------|----|
| Stop Switch and Switch Clip ..... | 12 |
|-----------------------------------|----|

|                      |    |
|----------------------|----|
| WILL NOT START ..... | 65 |
|----------------------|----|

|   |    |
|---|----|
| Emission Control System Information ..... | 72 |
|---|----|

|  |    |
|--|----|
| Emission Control System Warranty ..... | 86 |
|--|----|

## F

|                |    |
|----------------|----|
| FEATURES ..... | 17 |
|----------------|----|

|                                 |    |
|---------------------------------|----|
| Fuel Filler Cap Vent Knob ..... | 17 |
|---------------------------------|----|

### FUEL

|                          |    |
|--------------------------|----|
| FILTER REPLACEMENT ..... | 55 |
|--------------------------|----|

|             |    |
|-------------|----|
| Gauge ..... | 17 |
|-------------|----|

|                        |    |
|------------------------|----|
| Hose Connections ..... | 28 |
|------------------------|----|

|               |    |
|---------------|----|
| Priming ..... | 28 |
|---------------|----|

|                    |    |
|--------------------|----|
| Priming Bulb ..... | 17 |
|--------------------|----|

|                      |    |
|----------------------|----|
| Tank Placement ..... | 27 |
|----------------------|----|

|                       |    |
|-----------------------|----|
| RECOMMENDATIONS ..... | 45 |
|-----------------------|----|

|                        |    |
|------------------------|----|
| Fuse Replacement ..... | 66 |
|------------------------|----|

|   |    |
|---|----|
| <b>G</b>                                  |    |
| GEAR                                      |    |
| CASE OIL                                  |    |
| CHANGE .....                              | 52 |
| LEVEL CHECK .....                         | 51 |
| SHIFTING .....                            | 35 |
| Gearshift Lever .....                     | 14 |
| <b>H</b>                                  |    |
| HELPFUL TIPS AND SUGGESTIONS .....        | 60 |
| Honda Publications .....                  | 78 |
| <b>I</b>                                  |    |
| IMPORTANT SAFETY INFORMATION .....        | 7  |
| INSTALLATION .....                        | 19 |
| POSITION .....                            | 19 |
| IS YOUR OUTBOARD MOTOR READY TO GO? ..... | 25 |
| <b>K</b>                                  |    |
| Knowledge .....                           | 25 |
| <b>L</b>                                  |    |
| LUBRICATION POINTS .....                  | 53 |
| <b>M</b>                                  |    |
| MAINTENANCE                               |    |
| Inspection .....                          | 26 |
| SCHEDULE .....                            | 43 |
| SAFETY .....                              | 41 |
| MOTOR ANGLE                               |    |
| ADJUSTMENT .....                          | 21 |
| FOR CRUISING .....                        | 21 |

# INDEX

---

## N

Normal Engine Stopping ..... 34

## O

Oil Pressure Indicator ..... 17

OPERATION ..... 27

Operator Responsibility ..... 7

## OUTBOARD MOTOR

ATTACHMENT ..... 20

SAFETY ..... 7

Oxygenated Fuels ..... 71

## P

PORTABLE FUEL TANK PLACEMENT AND CONNECTIONS ..... 27

## R

### RECOIL STARTER

ROPE INSPECTION ..... 57

Refuel With Care ..... 8

REFUELING ..... 44

Removal From Storage ..... 64

## S

### SAFE

Apparel ..... 25

OPERATING PRECAUTIONS ..... 27

### SAFETY

LABEL LOCATIONS ..... 9

Inspection ..... 26

Precautions ..... 41

Serial Number Locations ..... 69

SERVICING YOUR OUTBOARD MOTOR ..... 40

SHEAR PIN AND PROPELLER REPLACEMENT ..... 58

SPARK PLUG SERVICE ..... 54

Specifications ..... 76

---

|  |    |
|--|----|
| Star Label .....                         | 74 |
| Starter Grip .....                       | 14 |
| STARTING THE ENGINE .....                | 29 |
| STEERING .....                           | 36 |
| Friction Bolt .....                      | 15 |
| STOPPING THE ENGINE .....                | 34 |
| STORAGE                                  |    |
| Precautions .....                        | 63 |
| Preparation .....                        | 60 |
| STORING YOUR OUTBOARD MOTOR .....        | 60 |
| SUBMERGED MOTOR .....                    | 67 |
| <b>T</b>                                 |    |
| TAKING CARE OF UNEXPECTED PROBLEMS ..... | 65 |
| TECHNICAL                                |    |
| AND CONSUMER INFORMATION .....           | 69 |
| INFORMATION .....                        | 69 |
| THE IMPORTANCE OF MAINTENANCE .....      | 40 |
| Throttle                                 |    |
| Friction Knob .....                      | 13 |
| Grip .....                               | 13 |
| Tilt Lever .....                         | 15 |
| TILTING THE OUTBOARD MOTOR .....         | 38 |
| TOOL KIT AND SPARE PARTS .....           | 42 |
| Transom Angle Adjusting Rod .....        | 16 |
| TRANSPORTING .....                       | 64 |
| <b>W</b>                                 |    |
| WIRING DIAGRAM .....                     | 88 |

---

# MEMO



---

# MEMO

---

**MEMO**

## QUICK REFERENCE INFORMATION

|             |                 |  |
|-------------|-----------------|--|
| Fuel        | Type            | Unleaded gasoline with a pump octane rating of 86 or higher (page 45)  |
|             | Capacity        | 3.0 US gal (12 ℓ)  |
| Engine Oil  | Type            | SAE 10W-30, API standard (SG, SH, SJ, SL), for general use (page 50)   |
|             | Capacity        | 0.85 US qt (0.8 ℓ)   |
| Gear Oil    | Type            | API standard (GL-4/5)<br>SAE 90 outboard motor gear oil  |
|             | Capacity        | 0.24 US qt (0.23 ℓ)  |
| Spark Plug  | Type            | DR-5HS (NGK)   |
|             | Gap             | 0.024-0.028 in (0.60-0.70 mm) (page 54)  |
| Carburetor  | Idle speed      | 1,200 ± 100  |
| Maintenance | Before each use | Check engine oil level (page 48).<br>Check fuel hose (page 26).<br>Check propeller and cotter pin (page 26).<br>Check anode (page 26). |
|             | First 20 hours  | Change engine oil (page 49).<br>Change gear oil (page 52).<br>Check carburetor linkage.<br>Grease lubrication points (page 53).        |
|             | Subsequent      | Refer to the maintenance schedule on page 43.  |

# HONDA

The Power of Dreams

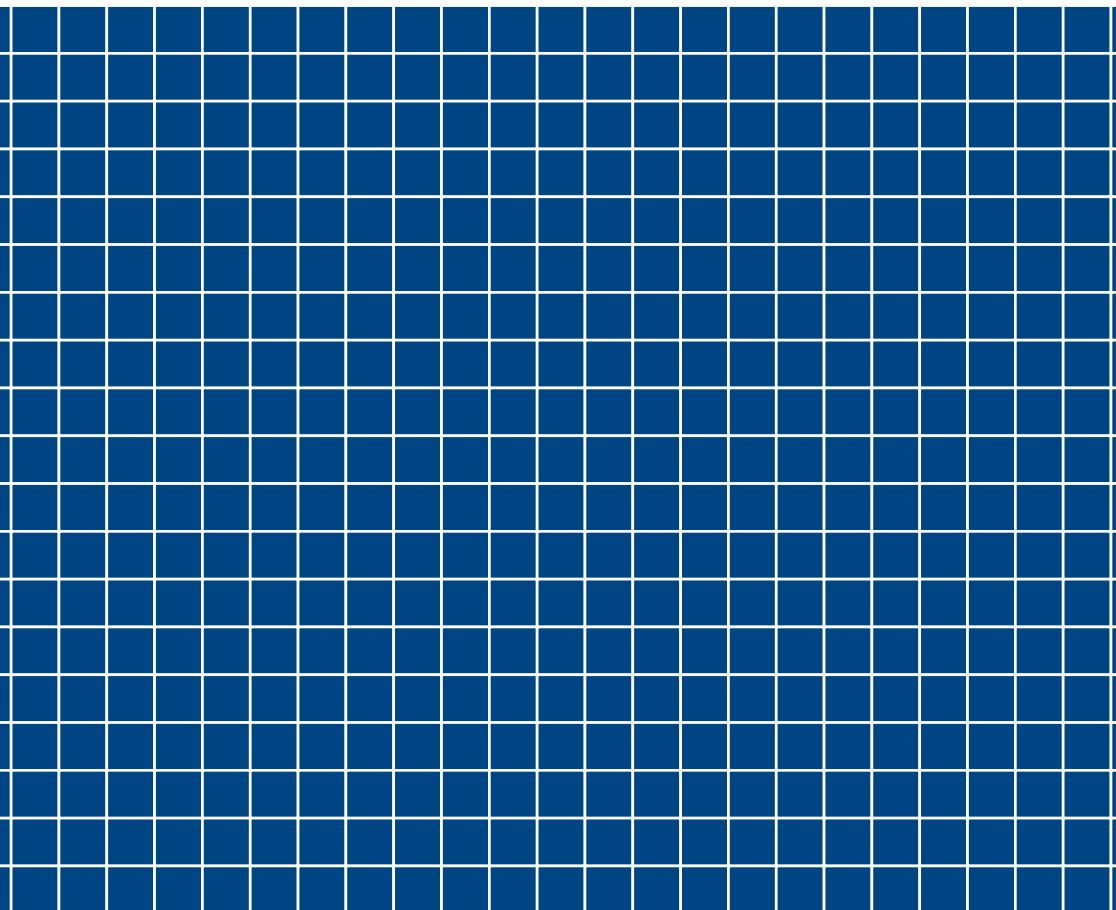

31881805  
00X31-881-8050

**EM3**

AH

英

Y

BF8AK0  
300.2006.03  
Printed in Japan