

# HONDA XR600R OWNER'S MANUAL

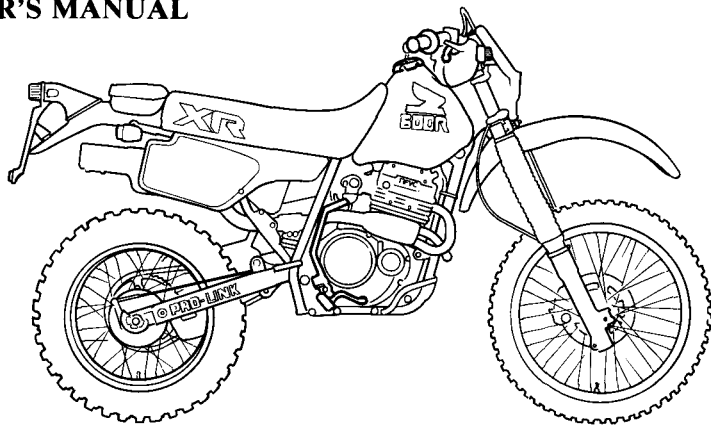

*All information in this publication is based on the latest production information available at the time of approval for printing. HONDA MOTOR CO., LTD. reserves the right to make changes at any time without notice and without incurring any obligation. No part of this publication may be reproduced without written permission.*

© Honda Motor Co., Ltd. 1985



## WELCOME

The motorcycle presents you a challenge to master the machine, a challenge to adventure. You ride through the wind, linked to the road by a vehicle that responds to your commands as no other does. Unlike an automobile, there is no metal cage around you. Like an airplane, a pre-ride inspection and regular maintenance are essential to your safety. Your reward is freedom.

To meet the challenges safely, and to enjoy the adventure fully, you should become thoroughly familiar with this owner's manual **BEFORE YOU RIDE THE MOTORCYCLE**.

When service is required, remember that your Honda dealer knows your motorcycle best. If you have the required mechanical "know-how" and tools, your dealer can supply you with an official Honda Shop Manual to help you perform many maintenance and repair tasks.

Pleasant riding, and thank you for choosing a Honda!

# CONTENTS

	Page		Page
<b>MOTORCYCLE SAFETY</b> .....	1	Spark Plug .....	52
Safe Riding Rules .....	1	Air Cleaner .....	54
Off-road Safety .....	2	Valve Clearance .....	55
Protective Apparel .....	2	Starter Decompressor .....	57
Modifications .....	2	Throttle Operation .....	59
Loading and Accessories .....	3	Carburetor .....	61
<b>DESCRIPTION</b> .....	5	Clutch .....	62
Parts Location .....	5	Front Brake .....	64
Serial Numbers .....	8	Rear Brake .....	66
Color Label .....	9	Brake Wear Indicators .....	68
Parts Function .....	10	Drive Chain .....	69
Fuel .....	30	Front Wheel Removal .....	74
Engine Oil Level Check .....	32	Rear Wheel Removal .....	76
Tires .....	34	Front Suspension .....	78
<b>OPERATION</b> .....	35	Rear Suspension .....	79
Pre-ride Inspection .....	35	Side Stand .....	80
Starting the Engine .....	36	Wheel Rims and Spokes .....	81
Manual Starter Decompressor .....	38	Headlight and Taillight .....	82
Flooded Engine .....	39	Stoplight Switch .....	83
Break-in .....	39	Turn Signal .....	84
Riding .....	40	<b>CLEANING</b> .....	85
High Altitude Riding .....	41	<b>STORAGE GUIDE</b> .....	86
Braking .....	42	<b>SPECIFICATIONS</b> .....	88
Parking .....	43	<b>NOISE EMISSION (AUSTRALIA ONLY)</b> .....	91
Anti-theft Tips .....	43	<b>WIRING DIAGRAM</b>	
<b>MAINTENANCE</b> .....	44		
Competition Inspection .....	45		
Maintenance Schedule .....	46		
Fuel Strainer Screen and Fuel Line .....	48		

# MOTORCYCLE SAFETY

## WARNING

*\* Motorcycle riding requires special efforts on your part to ensure your safety. Know these requirements before you ride.*

## SAFE RIDING RULES

1. Always make a pre-ride inspection (page 35) before you ride the motorcycle. You may prevent an accident or equipment damage.
2. Learn to ride in an uncongested off-road area free of obstacles before venturing into unfamiliar terrain.
3. Always obey local off-road riding laws and regulations.
4. Obtain permission to ride on private property. Avoid posted areas and obey “no trespassing” signs.
5. Ride with a friend on another motorcycle so that you can assist each other in case of trouble.
6. Familiarity with your motorcycle is critically important should a problem occur far from help.
7. Never ride beyond your ability and experience or faster than conditions warrant.
8. If you are not familiar with the terrain, ride cautiously. Hidden rocks, holes, or ravines could spell disaster.
9. Spark arresters and mufflers are required in most areas. Don’t modify your exhaust system. Remember that excessive noise bothers everyone and creates a bad image for motorcycling.
10. This motorcycle is not legally equipped to be ridden on the highway. Remember to walk an off-road motorcycle when crossing public highways, roads or streets.

## OFF-ROAD SAFETY

Learn to ride in an uncongested off-road area free of obstacles before venturing into unfamiliar terrain.

1. Always obey local off-road riding laws and regulations.
2. Obtain permission to ride on private property. Avoid posted areas and obey no trespassing signs.
3. Ride with a friend on another motorcycle so that you can assist each other in case of trouble.
4. Familiarity with your motorcycle is critically important should a problem occur far from help.
5. Never ride beyond your ability and experience or faster than conditions warrant.
6. If you are not familiar with the terrain, ride cautiously. Hidden rocks, holes, or ravines could spell disaster.
7. Spark arresters and mufflers are required in most areas. Don't modify your exhaust system. Remember that excessive noise bothers everyone and creates a bad image for motorcycling.

## PROTECTIVE APPAREL

1. Most motorcycle accident fatalities are due to head injuries: ALWAYS wear a helmet. You should also wear a face shield or goggles as well as boots, gloves, and protective clothing.
2. The exhaust system becomes very hot during operation, and it remains hot after operation. Never touch any part of the hot exhaust system. Wear clothing that fully covers your legs.
3. Do not wear loose clothing which could catch on the control levers, kickstarter, footpegs, drive chain, or wheels.

## MODIFICATIONS



- \* *Modification of the motorcycle, or removal of original equipment, may render the vehicle unsafe or illegal. Obey all federal, state and local equipment regulations.*

## LOADING AND ACCESSORIES

### WARNING

- \* A motorcycle is sensitive to changes in weight distribution. Addition of accessories or cargo can impair the motorcycle's stability and performance. To prevent an accident, use extreme care when adding and riding with cargo and accessories. These general guidelines may help you decide whether, or how to equip your motorcycle.*

### Loading

The vehicle capacity load is 220 lbs (100 kg). The combined weight of the rider, cargo, and all accessories must not exceed this limit.

1. Keep cargo and accessory weight low and close to the center of the motorcycle. Load weight equally on both sides to minimize imbalance. As weight is located farther from the motorcycle's center of gravity, handling is proportionally affected.

2. Luggage racks are for lightweight items. Bulky items may snag on a tree or other nearby objects causing loss of control.
3. All cargo and accessories must be secure for stable handling. Recheck cargo security and accessory mounts frequently.
4. Do not attach large or heavy items (such as a sleeping bag or tent) to the handlebars, front forks, or fender. Unstable handling or slow steering response may result.

### Accessories

Genuine Honda accessories have been specifically designed for and tested on this motorcycle.

Because the factory cannot test all other accessories, you are personally responsible for proper selection, installation, and use of non-Honda accessories. Always follow the guidelines under Loading, and these:

1. Carefully inspect the accessory to make sure it does not reduce ground clearance, or limit suspension travel, steering travel or control operation.
2. Do not add electrical equipment that will exceed the motorcycle's electrical system capacity. An electrical failure could cause a dangerous loss of lights or engine power at night, far from help.

## DESCRIPTION

## PARTS LOCATION

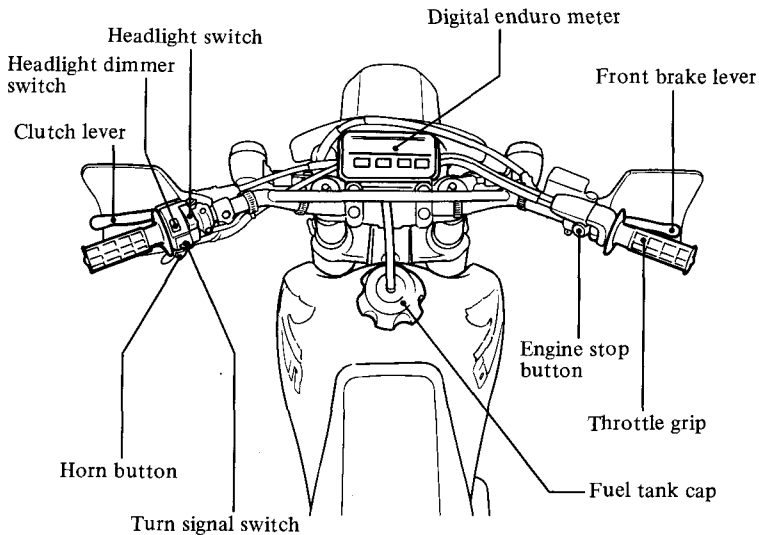

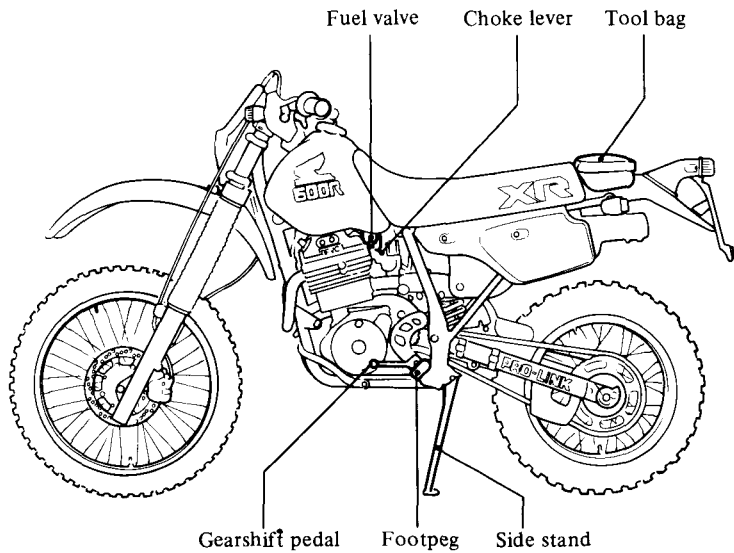

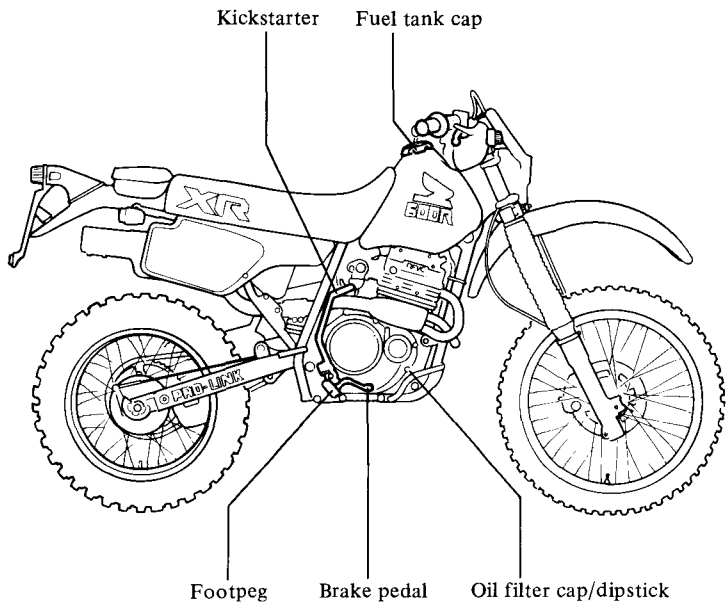

## SERIAL NUMBERS

The frame and engine serial numbers are required when registering your motorcycle. They may also be required by your dealer when ordering replacement parts.

Record the numbers here for your reference.

FRAME NO. \_\_\_\_\_

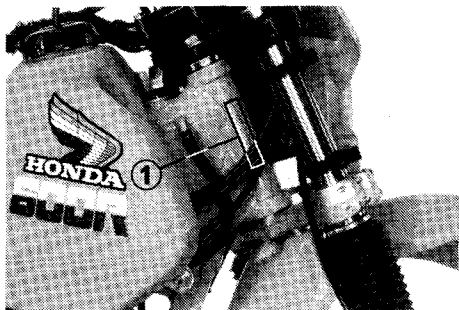

(1) Frame number

The frame number (1) is stamped on the right side of the steering head. The engine number (2) is stamped on the left side of the crankcase.

ENGINE NO. \_\_\_\_\_

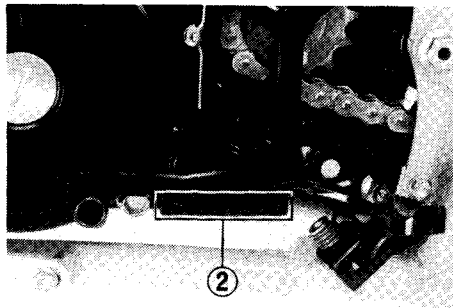

(2) Engine number

## COLOR LABEL

The color label (1) is attached to the frame behind the left side cover. It is helpful when ordering replacement parts. Record the color and code here for your reference.

COLOR \_\_\_\_\_

CODE \_\_\_\_\_

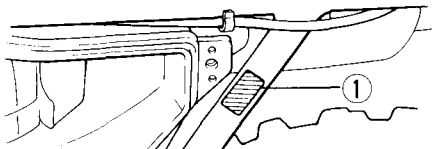



(1) Color label

## PARTS FUNCTION

The battery operated enduro meter is located on the headlight. Its functions are described in the tables on the following pages.

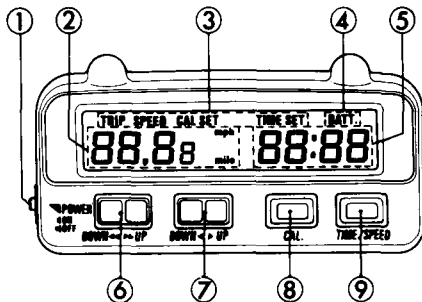
- (1) Power button
- (2) Trip/speedometer
- (3) Mode display
- (4) Battery indicator
- (5) Elapsed time meter
- (6) Fast up/down button
- (7) Slow up/down button
- (8) Calibration button
- (9) Time/speed button

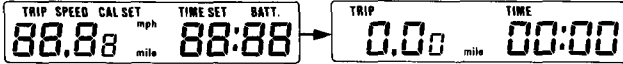

Ref.	Description	Function
1	Power button	<p>Turns enduro meter ON. Also operates following systems:  <u>Meter self-checking system:</u> All L.C. displays should light for a few seconds and then go out when this button is pressed.</p>  <p>The diagram shows two digital displays. The left display has labels 'TRIP SPEED CAL SET' above '88.88' and 'mph' to the right, with 'mile' below. The right display has labels 'TIME SET BATT.' above '88:88' and 'TRIP' above '0.00' and 'TIME' above '00:00', with 'mile' below. An arrow points from the right display to the left display.</p> <p><u>Auto power cut-off system:</u>  Power is cut off automatically after this unit has been left ON for 2-3 hours with motorcycle stationary and all controls not operated.</p>
2	Trip/speedometer	Shows accumulated mileage and speed.
3	Mode display	Shows modes depending on which way controls are operated with power button ON.
4	Battery indicator	<p>“BATT” is indicated on display when battery is low. Batteries should be replaced when this is indicated on display.</p>  <p>The diagram shows a digital display with labels 'TRIP' above '0.00' and 'TIME BATT.' above '00:00', with 'mile' below.</p>

Ref.	Description	Function
5	Elapsed time meter	Displays elapsed time.
6	FAST UP/DOWN button	Resets functions of elapsed time and mileage in 1 minute or 1 mile steps.
7	SLOW UP/DOWN button	Resets functions of elapsed time and mileage in 1 second or 0.1 mile steps.
8	Calibration (CAL) button	Calibrates mileage and speed on display for succeeding run.
9	Time/speed button	Starts elapsed time meter or resets time. Also used to select either tripmeter or speedometer.

NOTE: The enduro meter is not illuminated and cannot be used at night.

**TO SHOW ELAPSED TIME:**

- Turn the power button (1) ON.
- To start counting, press the time/speed button (9).
- To stop counting, press and hold the time/speed button (9).

**TO SHOW TRIP MILEAGE:**

- Turn the power button (1) ON.

**TO SHOW SPEED:**

- Turn the power button (1) ON.
- Press the time/speed button twice (9).

NOTE: For detailed procedures, refer to pages 14 thru 20.

## Digital Enduro Meter Battery Replacement

If the L.C. display shows "BATT", the meter batteries must be replaced with new ones.

1. Remove the headlight (page 82).
2. Disconnect the sensor wires from the meter wires at the connectors (1).
3. Remove the two bolts (2) attaching the meter retainer to the meter mount bracket and then pull out the meter (3).
4. Open the battery compartment cover (4) by turning the screw (5) counterclockwise.

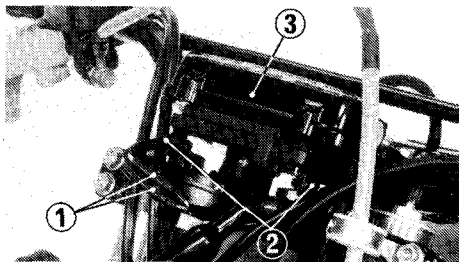

- (1) Connectors      (3) Meter  
(2) Bolts

5. Replace the batteries with new ones.  
Type of meter batteries: three AA

### CAUTION:

- \* Check that the batteries are installed in the battery compartment properly.
6. Install the meter in the reverse order of removal.

### CAUTION:

- \* Check that the water drain tube is connected to the meter securely.

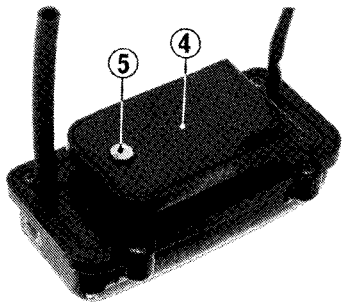

- (4) Cover      (5) Screw

## Digital Enduro Meter

The XR600R is equipped with an enduro meter which can show elapsed time, distance and speed. The meter also has a calibration function to adjust the tripmeter to a particular course.

### Power Button

After pushing and releasing the POWER button, the enduro meter will temporarily display all the modes and digital segments so you can make sure the liquid crystal display is functioning properly. The meter will then automatically switch to the TRIP and TIME modes and display zeroes.

When the meter is turned OFF, all recorded or preset distances and time will be cleared.

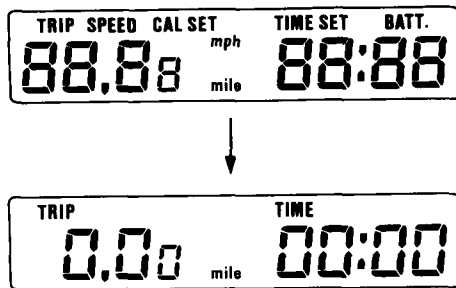

## Time/Speed Button



After the meter is turned ON, pressing and releasing the TIME/SPEED button will start the elapsed time function. The meter will begin to count seconds and minutes until 59:59 has been reached, whereupon the display will show 00:00 and begin counting again.



Press/Release

Count starts

To stop counting time, press and hold the TIME/SPEED button until the mode display shows TIME SET then release the button.



Press/Hold/  
Release

Count stops

If you want to preset the time function to a specific time (minutes and seconds), press and hold this button. Once the mode display shows TIME SET, keep the TIME/SPEED button depressed and then operate the FAST and SLOW UP/DOWN buttons to set the minutes and seconds respectively.

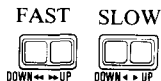

The TIME/SPEED button also switches the tripmeter function to the speedometer function, and vice versa, but only when the elapsed time meter is counting seconds and minutes. (When the timer is not counting, pressing and releasing the TIME/SPEED button starts the timer.)

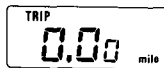

Press

The tripmeter will show mileage until 99.9 miles has been reached, whereupon the display will show 00.0 and begin counting again.

The tripmeter can be preset to a specific mileage when the enduro meter is in the TRIP mode. Use the FAST and SLOW UP/DOWN buttons to set the miles and tenths of miles respectively.

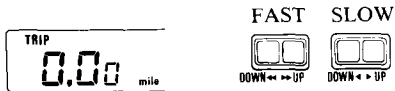

The speedometer will display speeds up to 125 mph.



### Fast and Slow Up/Down Buttons

These buttons are used to preset the elapsed time meter and tripmeter. Pressing and releasing one of the buttons will change the meter reading by one increment. Pressing and holding the buttons will change the meter reading continuously until the button is released.

To preset the elapsed time meter:

Press and hold the TIME/SPEED button. When the mode indicator displays TIME SET, press the FAST UP/DOWN buttons to count up or down whole minutes while holding the TIME/SPEED button down. Use the SLOW UP/DOWN buttons in the same manner to set the desired seconds.

### NOTE:

Adjusting the minutes with the FAST UP/DOWN buttons will “zero” the seconds display.

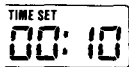

To preset the tripmeter:

When the mode indicator displays TRIP, use the FAST UP/DOWN buttons to set whole miles, and use the SLOW UP/DOWN buttons to set tenths of miles.

### NOTE:

Initial use of the calibration function will clear any preset mileage (see Cal Button.)

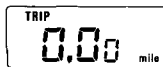

## Cal Button



The enduro meter has a calibration function which allows you to calibrate the tripmeter to a particular course's speed check.

Press and hold this button until the mode indicator displays CAL SET and the tripmeter displays 3.0. If the course you are riding has a speed check at 3.0 miles, release the button.

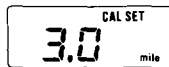

Press/Hold/  
Release

## NOTE:

- \* Releasing the button sets the CAL SET mode. Pushing the button again activates the calibration function, so be careful not to touch the CAL button again until you're at the starting line. Until the CAL button is pushed again, the meter will not count miles; so, you can ride the motorcycle before the start of the enduro without accumulating mileage on the meter.
- \* 3.0 miles is the standard distance memorized by the enduro meter and will always appear when the CAL button is pushed after the meter is turned ON; however, the calibration distance can be preset to any mileage from 1.0 to 49.9 miles. Once preset, the calibration distance will be memorized by the meter until it's turned OFF.

If you want to change the calibration distance, do not release the CAL button; keep the button depressed and operate the FAST and SLOW UP/DOWN buttons to adjust whole miles and tenths of miles respectively. Release the button.

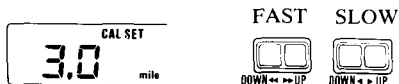

After you have set the calibration distance on the meter and you are at the start line of the enduro, push the CAL button again to allow the meter to begin computing the calibration distance. The mode indicator will display CAL.

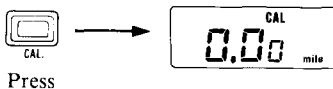

The tripmeter will now display uncalibrated distance until the CAL button is pushed again when you reach the speed check. Upon reaching the speed check and pushing the CAL button, the enduro meter will automatically calibrate the tripmeter to the course distances. The mode indicator will display TRIP and CAL.

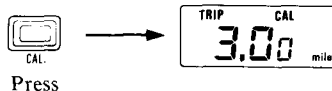

**NOTE:**

You must be within 90—110% of the calibration distance when pushing the CAL button at the course speed check in order for the calibration function to operate properly. If you push the CAL button before reaching 90% of the calibration distance, it will have no effect on the meter. If you ride past 110% of the calibration distance, the calibration function will be canceled and the meter will switch to the TRIP mode.

You can repeat the calibration operation at the start of another loop or for another speed check. If, for example, at the end of the first loop your tripmeter reads 68.3 miles, and it should read 70.0 miles for the start of the second loop, you can:

- Preset the mileage on the tripmeter to 70.0 miles.
- Reset the calibration distance as required.
- Before starting off, press the CAL button.

**NOTE:**

If you calibrated the meter at the start of the first loop, the tripmeter will read 70.0 miles again after pushing the CAL button. If you did not use the calibration function initially, then pushing the CAL button at the start of the second loop will clear the 70.0 miles on the tripmeter.

- Press the CAL button at the end of the calibration run. The meter is now recalibrated.

## Engine Stop Button

The engine stop button (1) is next to the left handlebar grip. Push the button until the engine stops completely.

## Switches

The four controls next to the left handlebar grip are:

### Headlight Switch (1)

The headlight switch has two positions: "H", and "OFF" marked by an orange dot.

H: Headlight and taillight on.

OFF (orange dot): Headlight and taillight off.

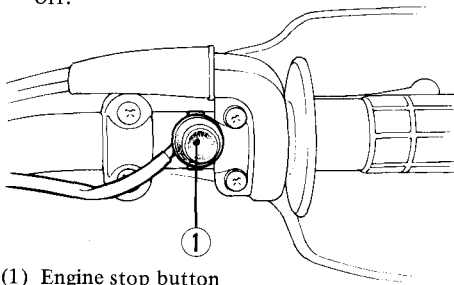

(1) Engine stop button

### Headlight Dimmer Switch (2)

Select Hi for high beam, Lo for low beam.

### Turn Signal Switch (3)

Move to L to signal a left turn, R to signal a right turn. Return to the center (off) when finished.

### Horn Button (4)

Press the button to sound the horn.

### NOTE:

\* The lights and horn will be dim when the engine is idling.

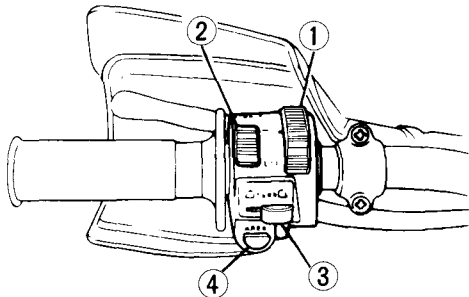

(1) Headlight switch (3) Turn signal switch  
(2) Headlight dimmer switch (4) Horn button

## Steering Lock (Australia only)

The motorcycle has a steering lock (1) on the steering column. To lock the steering, turn the handlebar all the way to the left, insert the key into the cylinder, turn the key 180° to the right. To unlock the steering, perform the locking sequence in the reverse order.

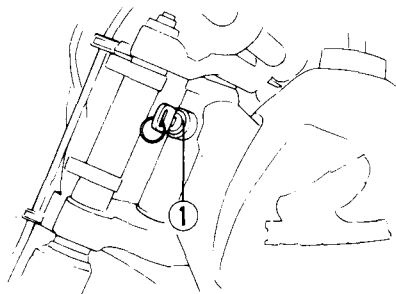

(1) Steering lock

## Tool Bag

A multi-purpose wrench (1) is in the tool bag (2) at the rear of the seat.

Some repairs, minor adjustments and parts replacement can be performed with this tool.

This owner's manual and other documents should be stored in the tool bag. When washing your motorcycle, be careful not to flood this area with water.

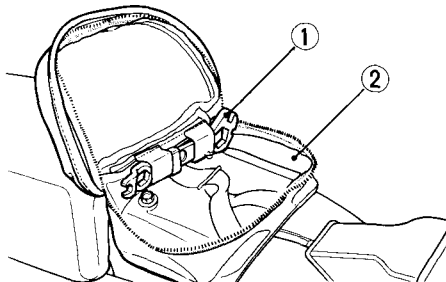

(1) Multi-purpose wrench  
(2) Tool bag

## Front Suspension

The front suspension system uses air assisted front forks. Though the standard air pressure is 0 psi (0 kPa, 0 kg/cm<sup>2</sup>), the

Condition	Air pressure	Oil volume
The entire range of travel is too hard.	Lower	—
The entire range of travel is too soft (bottoming).	Increase	—
Initial travel is good, but the final stages of travel are too soft (bottoming).	—	Increase
The initial stages of travel are good but the final stages are hard	—	Reduce
The initial stages of travel are too soft, but the final stages are good	Increase	Reduce
The initial stages of travel are too hard, but the final stages are good	Reduce	Increase

forks may be adjusted for the rider's weight and riding conditions by adjusting the air pressure and oil volume. Use the chart below to determine the correct adjustment for you.

### Air Pressure Adjustment

Low air pressure settings provide a soft ride and are for light loads and smooth riding conditions.

High air pressure settings provide a firm ride and are for heavy loads and rough riding conditions.

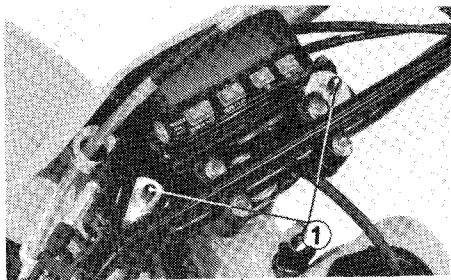

(1) Air-valve caps

For accurate pressure readings, check and adjust air pressure when the fork tubes are cold and with the front wheel off the ground.

1. Place a support under the engine to raise the front wheel off the ground.
2. Remove the air valve caps (1) and check the air pressure with a pressure gauge.

Standard air pressure: 0 psi (0 kPa, 0 kg/cm<sup>2</sup>)

3. If air pressure is insufficient, add air with a bicycle air pump. To decrease air pressure, depress the valve core.

Some air will be lost when using a pressure gauge. Determine the amount of loss and compensate accordingly. Also, be sure that the air pressure in both fork tubes is equal.

**NOTE:**

- \* Do not add a lot of air pressure at one time.
  - \* Use of more than 15 psi (100 kPa, 1.0 kg/cm<sup>2</sup>) is not recommended because fork action becomes very stiff.
4. Install the air valve caps.

**Oil Volume Adjustment:**

Low oil levels provide a soft ride and are for light loads and smooth riding conditions. High oil levels provide a firm ride and are for heavy loads and rough riding conditions.

1. Place a support under the engine to raise the front wheel off the ground.
2. Remove the air valve caps and release all air pressure.
3. Remove the fork cap bolts (2) and springs from the fork tubes.

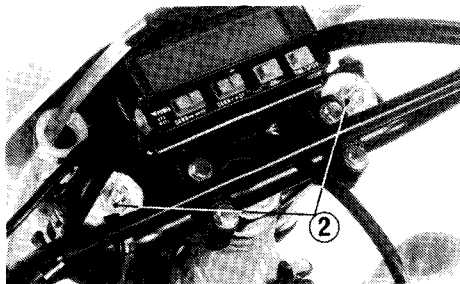

(2) Fork cap bolts

Inspect the O-ring on the cap bolts and replace if they are damaged.

**WARNING**

- \* *The fork cap bolts are under extreme spring pressure. Use care when removing the cap bolts and wear eye and face protection.*
4. Compress the forks all the way and measure the oil level (3) from the top of tubes.

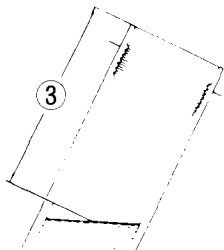

(3) Oil level

Standard oil level: 127 mm (5.0 in)  
To lower the oil level (decrease volume), use a syringe. Add oil with a graduated beaker for accurate measurements.  
The recommended oil level range is 117 mm (4.6 in) to 147 mm (5.8 in).

**NOTE:**

- \* Increase or decrease oil in increments of 5 cc (0.17 oz).
  - \* To prevent fork damage, do not fill past the recommended maximum level. Do not use a level lower than the recommended minimum to prevent poor performance.
5. Be sure the oil level is the same in both fork tubes.
  6. Clean and dry the fork spring with a lint free cloth. Install the fork spring and fork cap bolt. Torque the fork cap bolt to 15—30 N·m (1.5—3.0 kg·m, 11—22 ft·lb).

## Rear Suspension

The rear shock rebound damping and spring preload can be adjusted for rider weight and riding conditions.

### Rebound damping:

There are four detent rebound damping adjustment positions. Turn the damping adjuster (1) at the lower end of the shock for rider weight and riding conditions. The adjuster is marked for each adjustment position.



(1) Adjuster

### NOTE:

- \* Be sure the damping adjuster is not between positions but is located in a detent.

### Compression damping:

The compression damping adjuster has 14 positions or more. Turning, the adjuster knob one full turn clockwise advances the adjuster 6 positions. To adjust the adjuster to the standard position, proceed as follows:

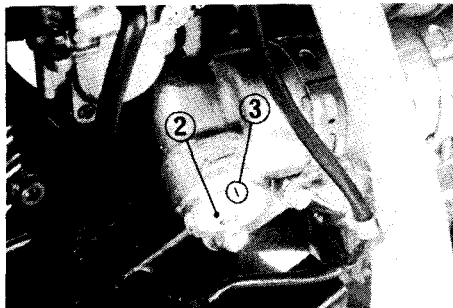

(2) Adjuster knob

(3) Red dot

1. Turn the adjuster knob (2) counter-clockwise until it will no longer go.
2. The adjuster is set in the standard position when the knob is turned clockwise 4-8 clicks with the red dot (3) on the knob aligned with the arrow on the reservoir.

#### Spring preload:

1. Remove the left and right side covers.
2. Remove the seat, exhaust muffler and air cleaner box.

#### **CAUTION:**

- \* *Be careful not to allow dust into the carburetor.*
3. Place a support under the engine to raise the rear wheel off the ground.
  4. Measure the spring length (4).

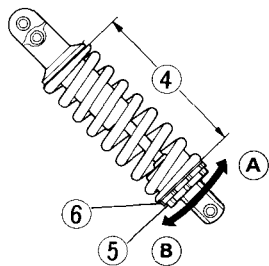

- (4) Spring length
- (5) Lock nut
- (6) Adjusting nut

- (A) Increase Preload
- (B) Decrease Preload

## Spring length;

Standard: 225.2 mm (8.87 in)

Minimum: 220.2 mm (8.67 in)

Maximum: 230.2 mm (9.06 in)

5. To increase spring preload; Loosen the lock nut (5) with the optional pin spanner and turn the adjusting nut (6) to shorten the spring length. Do not shorten to less than 220.2 mm (8.67 in).

To decrease spring preload; Loosen the lock nut (5) and turn the adjusting nut (4) to increase the spring length. Do not increase to more than 230.2 mm (9.06 in).

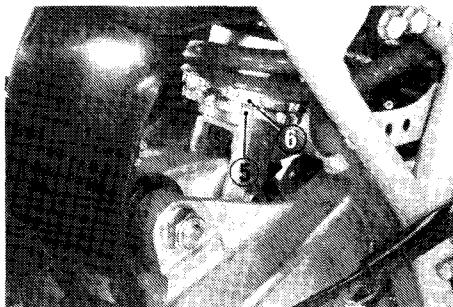

(5) Lock nut

(6) Adjusting nut

## WARNING

- \* *The rear shock absorber damper body contains pressurized nitrogen 142 psi (1,000 kpa, 10 kg/cm<sup>2</sup>). Do not attempt to disassemble the shock body.*
- \* *Do not disconnect the reservoir hose, or disconnect and refill the reservoir.*
- \* *Keep fire and heat away from the shock and its reservoir.*
- \* *If the shock absorber must be replaced, take the old unit to your authorized Honda dealer for proper disposal.*

## NOTE:

- \* Each turn of the adjuster equals 1.5 mm (0.06 in) of spring length and 15.5 kg (34.2 lbs) of spring preload.
  - \* An optional pin spanner is available for turning the lock nut and adjusting nut.
6. Tighten the lock nut and install the removed parts.

Condition and adjustment:

1. Always begin with Step I, then test ride the motorcycle. If the condition still exists, proceed to Step II and again test ride the motorcycle. If necessary, proceed to Step III.

Step Condition	I	II	III
Bottoming	Shorten the spring length (to increase the pre-load)	Turn the compression ad- juster to a stiffer position (to increase the damping force)	
Soft	Turn the compression ad- juster to a stiffer position (to increase the damping force)	Shorten the spring length (to increase pre-load)	Turn the rebound ad- juster to a stiffer position (to increase the damping force)
Hard	Increase the spring length (to decrease pre-load)	Turn the compression ad- juster to a softer position (to decrease damping force)	Turn the rebound adjuster to softer position (to de- crease damping force)
Excessive sinking	Shorten the spring length (to increase the pre-load)		

## FUEL

### Fuel Valve

The three way fuel valve (1) is on the left side near the carburetor.

### OFF

With the fuel valve in the OFF position, fuel cannot flow from the tank to the carburetors. Turn the valve OFF whenever the motorcycle is not in use.

### ON

With the fuel valve in the ON position, fuel will flow from the main fuel supply to the carburetors.

### RES

With the fuel valve in the RES position, fuel will flow from the reserve fuel supply to the carburetors. Use the reserve fuel only when the main supply is gone. The reserve fuel supply is 3.0 l (0.8 US gal). Refill the tank as soon as possible after switching to RES.

### WARNING

- \* *Know how to operate the fuel valve while riding the motorcycle. You may avoid a sudden stop in traffic.*
- \* *Be careful not to touch any hot engine parts while operating the fuel valve.*

### NOTE:

- \* Do not operate the motorcycle with the fuel valve in the RES position after refueling. You may run out of fuel with no reserve.

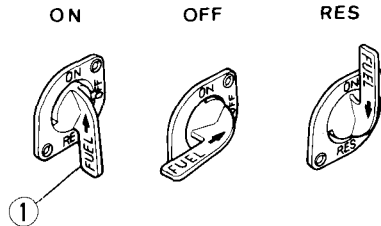

(1) Fuel valve

## Fuel Tank

Fuel tank capacity is 10.5 ℓ (2.8 US gal) including 3.0 ℓ (0.8 US gal) in the reserve supply.

To open the fuel tank cap (1), pull out the breather tube (2) from the steering stem nut. Then turn the fuel tank cap counter-clockwise.

Any automotive gasoline with a pump octane number ( $\frac{R + M}{2}$ ) of 86 or higher, or a

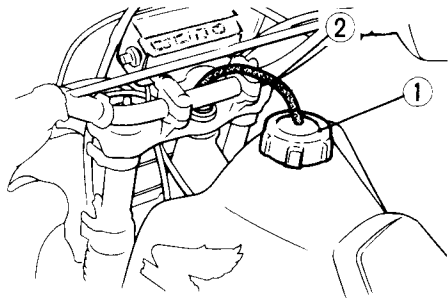

(1) Fuel tank cap

(2) Breather tube

research octane number of 91 or higher may be used. If “knocking” or “pinging” occurs, try a different brand of gasoline or a higher octane grade.

After refueling, be sure to tighten the fuel tank cap firmly by turning it clockwise. Insert the breather tube into the steering stem nut.

### WARNING

- \* *Gasoline is extremely flammable and is explosive under certain conditions. Refuel in a well-ventilated area with the engine stopped. Do not smoke or allow flames or sparks in the area where the motorcycle is refueled or stored.*
- \* *Do not overfill the tank (there should be no fuel in the filler neck). After refueling, make sure the tank cap is closed securely.*

## ENGINE OIL LEVEL CHECK

Check engine oil level each day before operating the motorcycle.

The oil filler cap is in front of fuel tank and has a dipstick for measuring the oil level. Oil level must be maintained between the upper and lower level marks on the dipstick.

1. With the motorcycle upright on level ground, start the engine let it idle for a few minutes.
2. Stop the engine and remove the oil filler cap/dipstick (1), wipe it clean, and reinsert the dipstick with out screwing it in. The oil level should be between the upper (2) and lower marks (3) on the dipstick.
3. If required, add the specified oil up the upper level mark. Do not overfill.
4. Reinstall the filler cap/dipstick. Check for oil leaks.

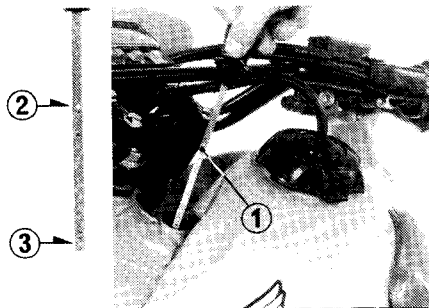

- (1) Oil filler cap/dipstick (3) Lower level mark  
(2) Upper level mark

## Engine Oil Recommendation

### USE HONDA 4-STROKE OIL OR AN EQUIVALENT

Use only high detergent, premium quality motor oil certified to meet US automobile manufacturers' requirements for Service Classification SE or SF.

Motor oils intended for Service SE or SF will show this designation on the container. The use of special oil additives is unnecessary and will only increase operating expenses.

#### CAUTION:

\* *Engine oil is a major factor affecting the performance and service life of the engine. Non-detergent, vegetable or castor based racing oils are not recommended.*

## Recommended Oil Viscosity

### SAE 20W—50/10W—40

#### NOTE:

\* Use SAE 10W—40 oil when the outside temperature is below 0°C (32°F).

Other viscosities shown in the chart below may be used when the average temperature in your riding area is within the indicated range.

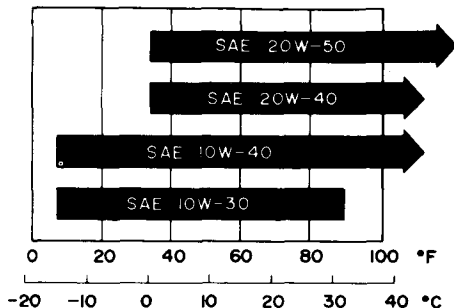

## TIRES

Proper air pressure will provide maximum stability, riding comfort and tire life.

Check tire pressures frequently and adjust if necessary.

### NOTE:

\* Tire pressure should be checked when the tires are “cold,” before you ride.

Off-road tires are standard on this model. Select the right replacement tires in accordance with the following specifications:

Cold tire pressures psi (kPa, kg/cm <sup>2</sup> )	Front: 15 (100, 1.0) Rear: 15 (100, 1.0)
Vehicle capacity load	100 kg (220 lbs)
Tire size	Front: 3.00-21-6 PR Rear: 5.10-17-6 PR

Check the tires for cuts, imbedded nails, or other sharp objects. See your authorized Honda Dealer for replacement of damaged tires or punctured inner tubes.

### WARNING

- \* *Do not attempt to patch a damaged tire or inner tube. Wheel balance and tire reliability may be impaired.*
- \* *Improper tire inflation will cause abnormal tread wear and create a safety hazard. Underinflation may result in the tire slipping on, or coming off of the rim.*
- \* *Operation with excessively worn tires is hazardous and will adversely affect traction and handling.*

Replace tires before tread depth at the center of the tire reaches the following limit:

Minimum tread depth
3 mm (1/8 in)

## OPERATION

### PRE-RIDE INSPECTION

#### WARNING

*\* If the Pre-ride Inspection is not performed, serious damage or an accident may result.*

Inspect your motorcycle every day before you ride it. The items listed here will only take a few minutes to inspect, and in the long run they can save time, expense, and possibly your life.

1. Engine oil level—add engine oil if required (page 32). Check for leaks.
2. Fuel level—fill the fuel tank when necessary (page 31). Check for leaks.
3. Brakes—check operation; Check operation; make sure there is no brake fluid leakage. Adjust free play if necessary (page 64–67).
4. Tires—check condition and pressure (page 34).
5. Spokes and rim locks—check and tighten if necessary (page 81).
6. Drive chain—check condition and slack (pages 69–73). Adjust and lubricate if necessary.
7. Chain guide slider and slipper—check slider wear (page 70).
8. Throttle—check for smooth opening and closing in all steering positions (pages 59–60).
9. Clutch—check operation, and adjust if necessary (page 62–63).
10. Headlight—check for proper operation.
11. Spark plug and high tension terminal—check for looseness.
12. Engine stop button—check for proper function (page 21).
13. Nuts, Bolts, Fasteners—check front wheel to see that the axle nut and axle holder nuts are tightened securely. Check security of all other nuts, bolts, and fasteners.

Correct any discrepancy before you ride. Contact your authorized Honda dealer for assistance if you cannot correct the problem.

## STARTING THE ENGINE

### WARNING

- \* *Never run the engine in a closed area. The exhaust contains poisonous carbon monoxide gas.*
- \* *Attempting to start the engine with the transmission in gear and the clutch engaged may result in injury or damage.*

### NOTE:

- \* This motorcycle can be kickstarted with the transmission in gear by disengaging the clutch before operating the kickstarter.

### Preparation

Make sure that the transmission is in neutral. Turn the fuel valve ON.

### Starting Procedure

To restart a warm engine, follow the procedure for "High Air Temperature."

### Normal Air Temperature

10°—35°C (50°—95°F)

1. Pull the choke lever (1) up all the way to "Fully Open" (A).
2. Keep the throttle closed.
3. Operate the kickstarter to start the engine. Starting from the top of the stroke, kick through to the bottom with a rapid, continuous motion.

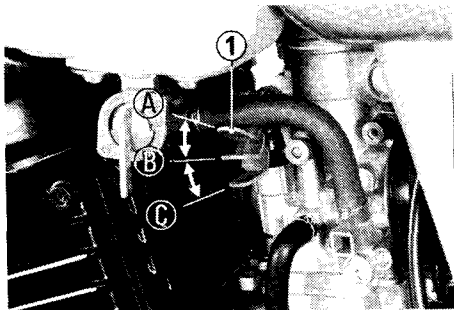

(1) Choke lever  
(A) Fully Closed

(B) Detent Position  
(C) Fully Open

**CAUTION:**

- \* *Do not allow the kickstarter to snap back against the pedal stop, as engine case damage could result.*
4. Immediately after the engine starts, push the choke lever down to the Detent Position (B).
  5. About a half minute after the engine starts, push the choke lever down all the way to “Fully Closed” (C).
  6. If idling is unstable, open the throttle slightly.

High Air Temperature

35°C (95°F) or above

1. Do not use the choke.
2. Keep the throttle closed.
3. Start the engine (See step 3 under “Normal Air Temperature”).

**NOTE:**

If the engine fails to restart, follow the procedure described below:

- \* Pull the decompression lever in, open the throttle fully, and operate the kickstarter pedal several times to clear the engine.
- \* Release the decompression lever. Start the engine (See step 3 under “Normal Air Temperature”).

Low Air Temperature

10°C (50°F) or below

1. Follow steps 1—3 under “Normal Air Temperature.”
2. If idling is unstable, push the choke lever down to the Detent Position (B).
3. Warm up the engine by opening and closing the throttle slightly.
4. Continue warming up the engine until it will idle smoothly with the choke lever pushed down all the way to “Fully Closed” (C).

**CAUTION:**

- \* *Extended use of the choke may impair piston and cylinder wall lubrication.*

## MANUAL STARTER DECOMPRESSOR

Although an engine decompression system is interlocked with the kickstarter, the manual starter decompressor can also be used if you experience starting difficulties.

To operate:

1. Push down lightly on the kickstarter until you feel some resistance.
2. Pull the decompressor lever (1) and push the kickstarter down again slowly about 1/4 to 1/2 of a full stroke.
3. Release the decompressor lever and kickstart the motorcycle in the usual manner.

The manual starter decompressor can also help restart the engine in an off-road situation where the motorcycle is rolling down a hill.

1. Close the throttle, disengage the clutch and shift into 2nd or 3rd gear.
2. With the motorcycle rolling, release the clutch.

3. If the rear tire skids instead of turning over the engine, pull the decompressor lever. Releasing compression allows the rear wheel to roll while turning the engine over.
4. Release the decompressor lever. If the engine does not start, pull the decompressor lever again. Wait until the motorcycle gains speed and release the decompressor lever.

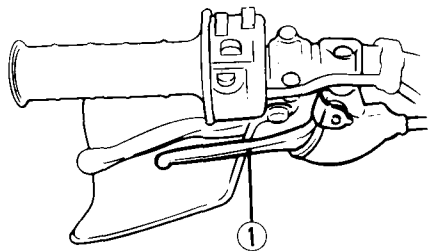

(1) Decompressor lever

## **FLOODED ENGINE**

If the engine fails to start after repeated attempts, it may be flooded with excess fuel. To clear a flooded engine, stop the engine by pressing the engine stop button and push the choke lever down to the Fully Open position (C). Open the throttle fully and pull the manual decompression lever and crank the engine several times with the kickstarter while pushing the engine stop button. Release the engine stop button and follow the “High Air Temperature” starting procedure.

## **BREAK-IN**

During the first 200 miles (350 km), avoid full throttle use and never lug the engine. Do not operate at any one speed for prolonged periods.

During initial break-in, newly machined surfaces will be in contact with each other and these surfaces will wear in quickly. Break-in maintenance at 200 miles (350 km) is designed to compensate for this initial minor wear. Timely performance of the break-in maintenance will ensure optimum service life and performance from the engine.

## RIDING

### WARNING

- \* *Review Motorcycle Safety (pages 1–4) before you ride.*
  - \* *Make sure the side stand is fully retracted before riding the motorcycle. If the stand is extended, it may interfere with control during a left turn.*
1. After the engine has been warmed up, the motorcycle is ready for riding.
  2. While the engine is idling, pull in the clutch lever and depress the gearshift pedal to shift into 1st (low) gear.
  3. Slowly release the clutch lever and at the same time gradually increase engine speed by opening the throttle. Coordination of the throttle and clutch lever will assure a smooth positive start.
  4. When the motorcycle attains a moderate speed, close the throttle, pull in the clutch lever and shift to 2nd gear by raising the gearshift pedal.

5. This sequence is repeated to progressively shift to 3rd, 4th, 5th (top) gears.
6. Raise the pedal to shift to a higher gear and depress the pedal to down shift. Each stroke of the pedal engages the next gear in sequence. The pedal automatically returns to the horizontal position when released.

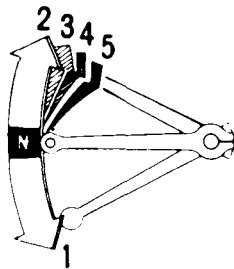

Shifting pattern

 **WARNING**

- \* *Do not downshift when traveling at a speed that would force the engine to overrev in the next lower gear, or cause the rear wheel to lose traction.*

**CAUTION:**

- \* *Do not shift gears without disengaging the clutch and closing the throttle. The engine and drive train could be damaged by overspeed and shock.*
- \* *Do not tow the motorcycle or coast for long distances while the engine is off. The transmission will not be properly lubricated and damage may result.*

## HIGH ALTITUDE RIDING

When operating this motorcycle at high altitude the air-fuel mixture becomes overly rich. driveability and performance may be reduced and fuel consumption increased. the carburetor can be modified to compensate for this high altitude richness. However, the carburetor must be returned to standard factory specifications when lower altitude riding is desired. See your authorized Honda dealer for this high altitude modification.

**CAUTION:**

- \* *Sustained operation at lower altitudes with high altitude carburetor modifications may cause engine overheating and damage.*

## BRAKING

1. For normal braking, gradually apply both front and rear brakes while downshifting to suit your road speed.
2. For maximum deceleration, close the throttle and apply the front and rear brakes firmly. Disengage the clutch before the motorcycle stops.

### WARNING

- \* *Independent use of only the front or rear brake reduces stopping performance. Extreme braking may cause either wheel to lock, reducing control of the motorcycle.*
- \* *When possible, reduce speed or brake before entering a turn; closing the throttle or braking in mid-turn may cause wheel slip. Wheel slip will reduce control of the motorcycle.*
- \* *When riding in wet or rainy conditions, or on loose surfaces, the ability to maneuver and stop will be reduced. All of your actions should be smooth under these conditions. Sudden acceleration, braking or turning may cause loss of control. For your safety, exercise extreme caution when braking, accelerating or turning.*
- \* *When descending a long, steep grade, use engine compression braking by downshifting, with intermittent use of both brakes. Continuous brake application can overheat the brakes and reduce their effectiveness.*

## **PARKING**

1. After stopping the motorcycle, shift the transmission into neutral and turn the fuel valve OFF. Press the engine stop button until the engine stops completely.
2. Use the side stand to support the motorcycle while parked.

### **CAUTION:**

- \* *Park the motorcycle on firm, level ground to prevent it from falling over.*

## **ANTI-THEFT TIPS**

1. Be sure the registration information for your motorcycle is accurate and current.
2. Park your motorcycle in a locked garage whenever possible.
3. Use an additional anti-theft device of good quality.
4. Put your name, address, and phone number in this Owner's Manual and keep it on your motorcycle at all times. Many times stolen motorcycles are identified by information in the Owner's Manuals which are still with them.

NAME: \_\_\_\_\_

ADDRESS: \_\_\_\_\_

\_\_\_\_\_

\_\_\_\_\_

PHONE NO.: \_\_\_\_\_

## MAINTENANCE

- When service is required, remember that your authorized Honda dealer knows your motorcycle best and is fully equipped to maintain and repair it. The scheduled maintenance may be performed by a qualified service facility that normally does this kind of work; or you may perform most of the work yourself if you are mechanically qualified.
- The maintenance intervals shown in the following schedule are based upon average riding conditions. Machines subjected to severe use (competition), or ridden in unusually muddy or dusty areas, require more frequent servicing.
- Consult your authorized Honda dealer for recommendations applicable to your individual needs and use.
- If your motorcycle is involved in a collision, have your Honda dealer inspect the major components, including frame, suspension and steering parts, for misalignment or damage.

### WARNING

- \* *Stop the engine and support the motorcycle securely on a level surface before performing any maintenance.*
- \* *Use new, genuine Honda parts or their equivalent for maintenance and repair. Parts which are not of equivalent quality may impair the safety of your motorcycle.*

## COMPETITION INSPECTION-Check all items before each race

No.	ITEMS	INSPECT FOR:	ACTION	REFER TO PAGE
1	All Pre-ride Inspection items			Page 35
2	Engine oil	Contaminants	Change	Page 32
3	Fuel line	Deterioration, damage or leakage	Replace	Page 48
4	Valve clearance	Correct clearance	Adjust	Pages 55-56
5	Carburetor-idle speed	Correct idle speed	Adjust	Page 59
6	Carburetor-choke	Proper operation	—	—
7	Decompression mechanism	Proper free play	Adjust	Pages 57-58
8	Clutch discs	Proper operation, see NOTE 1	Replace	—
9	Air cleaner element	Contamination or tears	Clean or replace	Page 54
10	Spark plug	Tightness, proper heat range, and high-tension terminal security	Tighten, replace or secure	Pages 52-53
11	Steering head	Free rotation of handlebars and steering stem nut tightness	Adjust or retighten	—
12	Front suspension	Smooth operation, no oil leaks, good boot condition, air pressure and oil volume	Replace or adjust	Pages 23-25, 78
13	Rear suspension	Smooth operation, no oil leaks and spring height	Replace or adjust	Pages 26-29, 79
14	Swingarm bearings	Smooth operation	Replace	—
15	Rear suspension linkage bushings	Wear	Replace	—
16	Brake shoes/Pads	Wear beyond service limit	Replace	Pages 68
17	Drive chain	Length: 1700 mm (66.9 in)/105 pins, max.	Replace	Pages 69-73
18	Sprockets	Wear and secure installation	Replace or tighten	Page 81
19	Seat	Security	Tighten	—
20	Headlight	Proper beam aim	Adjust	Page 82
21	Digital enduro meter battery	Proper operation	Replace	Page 13
22	Control cables	Smooth operation, kinks and correct routing	Lubricate or replace	—
23	Engine mounting bolts	Tightness	Tighten	—

NOTE 1: Competition use may cause more rapid clutch disc wear. Refer to the official Honda Shop Manual, or see your authorized Honda dealer for clutch disassembly and wear inspection.

NOTE: Refer to Maintenance Schedule (page 50-51) for regular service intervals.

## MAINTENANCE SCHEDULE

Perform the Pre-ride Inspection (Page 35) at each scheduled maintenance period.

I : Inspect and Clean, Adjust, Lubricate or Replace if necessary.

C: Clean    R: Replace    A: Adjust    L: Lubricate

ITEM	FREQUENCY	EVERY	BREAK-IN MAINT.	REGULAR MAINT. INTERVAL	Refer to
			200 mi	1000 mi	
			350 km	1600 km	
*	FUEL LINE			I	48
*	FUEL STRAINER SCREEN			C	48
*	THROTTLE OPERATION			I	59-60
	AIR CLEANER	NOTE 1		EVERY 500 mi (800 km) C	54
	SPARK PLUG			I	52-53
*	VALVE CLEARANCE		I	I	55-56
	ENGINE OIL		R	R	49-50
	ENGINE OIL FILTER		R	R	51
*	ENGINE OIL STRAINER SCREEN IN DOWN TUBE			C	—
*	DECOMPRESSOR SYSTEM		I	I	57-58
*	CARBURETOR IDLE SPEED		I	I	59
	DRIVE CHAIN	NOTE 1	I, L	EVERY 300 mi (500 km) I, L	69-73

ITEM	FREQUENCY	EVERY	BREAK-IN MAINT.		REGULAR MAINT. INTERVAL		
			200 mi	350 km	1000 mi	1600 km	Refer to
	DRIVE CHAIN GUIDE SLIDER				I	70	
	DRIVE CHAIN SLIPPER				I	70	
	BRAKE FLUID	2 YEARS *R			I	64	
	BRAKE SHOE/PAD WEAR				I	68	
	BRAKE SYSTEM		I		I	64-68	
*	HEADLIGHT AIM				I	82	
	CLUTCH SYSTEM		I		I	62-63	
	SIDE STAND				I	80	
*	SUSPENSION				I	78-79	
	SWINGARM BEARING				I, L	—	
	REAR SUSPENSION LINKAGE				I, L	79	
*	NUT, BOLT, FASTENER		I		I	—	
**	WHEEL		I		I	81	
**	STEERING HEAD BEARING		I		I	—	

\* SHOULD BE SERVICED BY AN AUTHORIZED HONDA DEALER UNLESS THE OWNER HAS PROPER TOOLS AND SERVICE DATA AND IS MECHANICALLY QUALIFIED REFER TO THE OFFICIAL HONDA SHOP MANUAL.

\*\* IN THE INTEREST OF SAFETY. WE RECOMMEND THESE ITEMS BE SERVICED ONLY BY AN AUTHORIZED HONDA DEALER.

NOTE: 1. Service more frequently when ridden in wet or dusty conditions.

## FUEL STRAINER SCREEN AND FUEL LINE

The fuel filter is incorporated in the fuel valve. An accumulation of dirt in fuel strainer screen will restrict the flow of fuel and therefore, the fuel strainer screen should be serviced periodically.

1. Drain the fuel from the fuel tank.  
Disconnect the fuel line.

### WARNING

\* *Gasoline is extremely flammable and is explosive under certain conditions. Perform this operation in a well-ventilated area. Do not smoke or allow flames or sparks in the area.*

2. Remove the fuel valve (1) by removing the mounting screws (2) and collar. Remove the fuel strainer screen (3) and wash it in clean non-flammable or high flash point solvent.

### WARNING

\* *Never use gasoline or low flash point solvents for cleaning the fuel strainer screen. A fire or explosion could result.*

3. Make sure the O-ring (4) on the fuel strainer screen pipe is in good condition. Reinstall the fuel strainer screen and fuel valve in the reverse order of removal and turn the fuel valve ON. Check for leaks.
4. Check the fuel line (5) for deterioration, damage or leakage. Replace it if necessary.

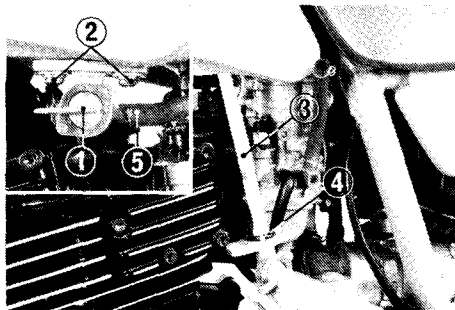

- |                          |               |
|--------------------------|---------------|
| (1) Fuel valve           | (4) O-ring    |
| (2) Mounting screws      | (5) Fuel line |
| (3) Fuel strainer screen |               |

## Engine Oil

Engine oil quality is the chief factor affecting engine service life. Change the engine oil when specified by the maintenance schedule.

### NOTE:

\* Change engine oil with the engine at normal operating temperature and the motorcycle on the side stand to assure complete and rapid draining.

1. Start the engine and let it idle for a few minute.
2. Place an oil drain pan under the crankcase. Remove the oil filler cap/dipstick and drain bolt (1) on the down tube and drain bolt (2) on the left crankcase.
3. Operate the kickstarter several times while pushing down the engine stop button to drain any oil which may be left in the engine.
4. After the oil has completely drained, make sure the sealing washers on the drain plugs are in good condition.

5. Install the drain bolts

Drain bolt on the crankcase torque 30—40 N·m (3.0—4.0 kg·m, 22—29 ft·lb).

Drain bolt on the down tube torque 35—45 N·m (3.5—4.5 kg·m, 25—32 ft·lb).

### CAUTION:

\* *Oil quantity is about 1.5 l (1.6 US qt) at oil change. To fill the oil tank up to the upper level, oil should be added in two steps.*

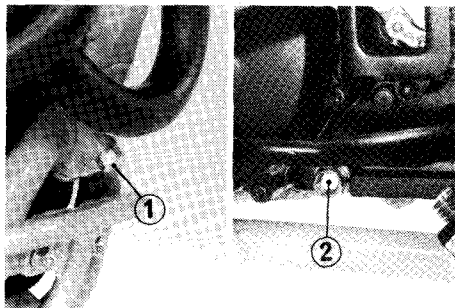

(1) Drain bolt (down tube)

(2) Drain bolt (left crankcase)

6. Pour 1.5 l (1.6 US qt) of specified oil into the oil tank. Install the oil filler cap/dipstick.
7. With the motorcycle upright on level ground, start the engine and let it idle for a few minutes.
8. Stop the engine and add the specified oil up the upper level mark.
9. Reinstall the filler cap/dipstick. Check for oil leaks.

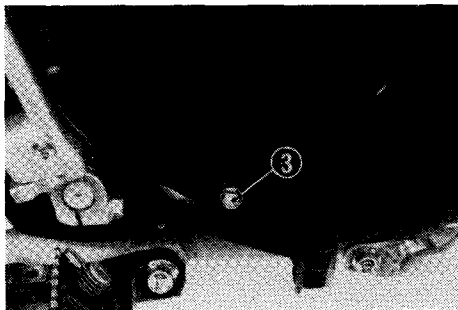

(3) Check bolt

**NOTE:**

- \* The engine contains a crankcase oil level check bolt (3). The oil level is correct if it is not flush with the crankcase lower edge of the check bolt hole.
- \* Do not check the oil level immediately after the engine has been operated at high speeds. Make sure that motorcycle is standing upright on level ground while idling.

**CAUTION:**

- \* *Running the engine with insufficient oil can cause serious engine damage.*

## Engine oil filter

### NOTE:

- \* Change the filter after draining the engine oil.
1. Remove the oil filter bolt (1) and cover (2).
  2. Remove the oil filter element (3) from the cover.
  3. Check that the O-rings (4) on the oil filter bolt and cover are in good condition.

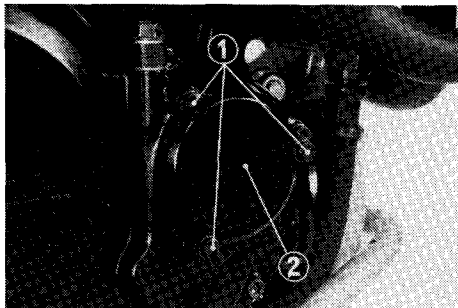

(1) Bolts  
(2) Cover

4. Insert a new oil filter element. Check that all parts are installed as shown. Install the oil filter cover.

### Oil Filter Bolt Torque:

8—10 N·m (0.8—1.0 kg-m,  
5—7 ft-lb)

5. Perform steps 6—9 of Engine oil Change.

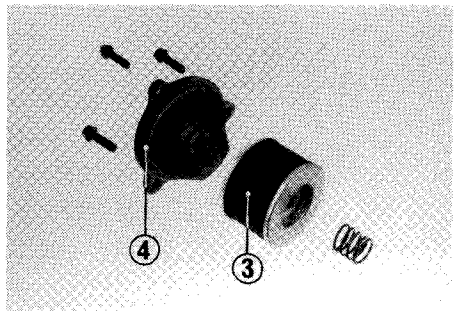

(3) Element  
(4) O-ring

## SPARK PLUG

Recommended plugs:

Standard:

DPR8EA-9 (NGK) or X24EPR-U9 (ND)

For most riding conditions this spark plug heat range number is satisfactory. However, if the motorcycle is going to be operated for extended periods at high speeds or near maximum power in hot climates, the spark plug should be changed to a colder heat range number.

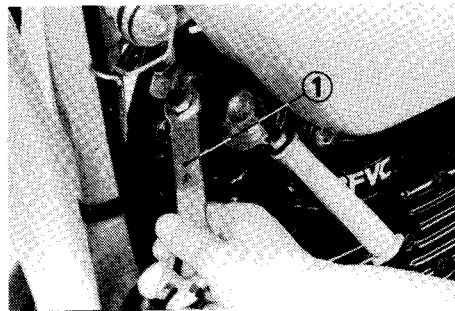

(1) Multi-purpose wrench

1. Clean any dirt from around the spark plug base.
2. Disconnect the spark plug cap and remove the spark plug with the multipurpose wrench (1) provided in the tool bag.
3. Visually inspect the spark plug electrodes for wear. The center electrode should have square edges and the side electrode should not be eroded. Discard the spark plug if there is apparent wear or if the insulator is cracked or chipped.

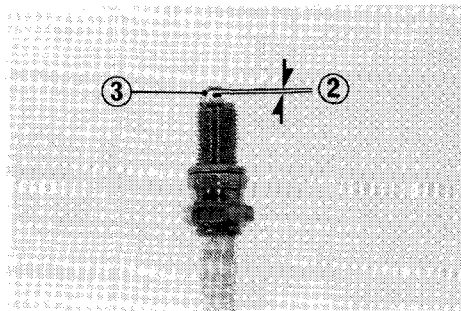

(2) Spark plug gap

(3) Side electrode

4. Make sure that the spark plug gap (2) is 0.8—0.9 mm (0.031—0.035 in) using a wire-type feeler gauge. If adjustment is necessary, bend the side electrode (3) carefully. Make sure the plug washer is in good condition.
5. With the plug washer attached, thread the spark plug in by hand to prevent cross-threading.
6. Tighten a new spark plug 1/2 turn with a spark plug wrench to compress the washer. If you are reusing a plug, it should only take 1/8—1/4 turn after the plug seats.

**CAUTION:**

- \* *The spark plug must be securely tightened. An improperly tightened plug can become very hot and possibly damage the engine.*
- \* *Never use a spark plug with an improper heat range.*

## AIR CLEANER

The air cleaner should be serviced at regular intervals (page 46). When riding in dusty areas, more frequent service may be necessary.

1. Remove the left side cover (1) by turning the latches (2) 90° counterclockwise and pulling the cover outward.
2. Remove the set spring (3).
3. Remove the air cleaner element (4).
4. Wash the element in clean nonflammable or high flash point solvent and dry it thoroughly.

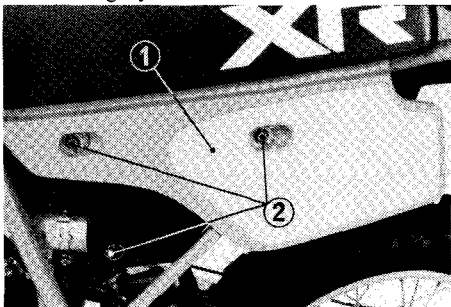

(1) Side cover (2) Latches

### WARNING

- \* *Never use gasoline or low flash point solvents for cleaning the air cleaner element. A fire or explosion could result.*
5. Soak the element in clean gear oil (SAE 80-90) until it is saturated. Then squeeze it to remove the excess.
  6. Install the element with the lug on the holder aligned with the hole in the element, then install the set spring and left side cover.

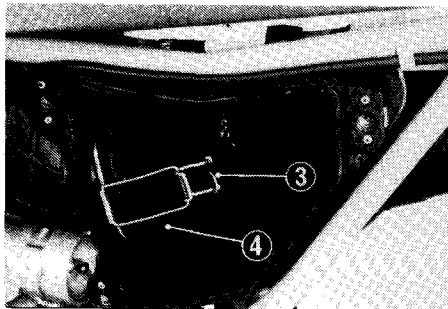

(3) Set spring (4) Air cleaner element

## VALVE CLEARANCE

Excessive valve clearance will cause noise. Little or no clearance will prevent the valve from closing and cause valve damage and power loss. Check valve clearance at the specified intervals.

### NOTE:

\* Checking or adjusting valve clearance should be performed while the engine is

cold. The clearance may increase as the engine temperature rises.

1. Turn the fuel valve OFF and remove the seat and fuel tank.
2. Remove the crankshaft hole cap (1) and timing mark hole cap (2).
3. Remove the valve adjuster covers.
4. Rotate the crankshaft counterclockwise and align the T mark (3) with the index mark (4). Make sure the piston is at the

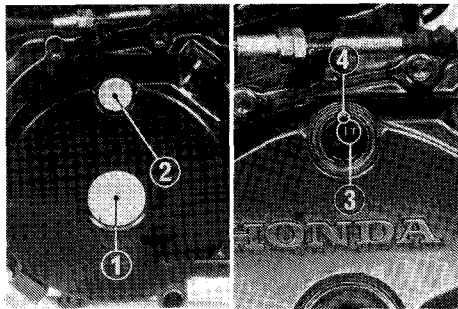

- (1) Crankshaft hole cap    (3) "T" mark  
(2) Timing mark hole cap    (4) Index mark

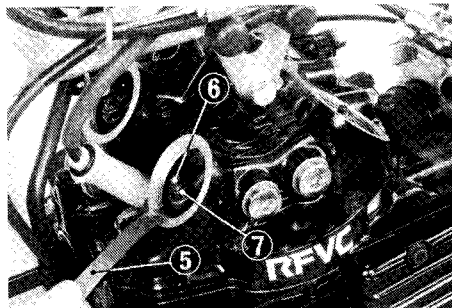

- (5) Feeler gauge                      (7) Lock nut  
(6) Adjusting screw

top of the compression stroke by jiggling the rocker arms with your fingers. If they are free, the piston is at the top of the compression stroke. If they are tight, rotate the crankshaft 360° and realign the marks.

5. Check the clearance by inserting the feeler gauge (5) between the adjusting screw (6) and valve stem.

Standard clearance:

In. 0.05 mm (0.002 in)

Ex. 0.08 mm (0.003 in)

Adjust the valves by loosening the lock nut (7) and turning the adjusting screw (6) until there is a slight drag on the feeler gauge. After tightening the lock nut (7), recheck the clearance.

6. Adjust the starter decompressor (see page 57–58).
7. Install all parts in the reverse order of disassembly.

## STARTER DECOMPRESSOR

Excessive decompressor lifter lever free play will cause hard starting, and insufficient free play may cause erratic idling and valve burning.

### CAUTION:

\* *Adjustment must be made for both manual and kickstarter decompressor.*

### NOTE:

\* Adjust the decompressor linkage after adjusting the valve clearance.

1. Loosen the manual decompressor lock nut (1) and the manual decompressor adjusting nut (2).
2. Disconnect the manual decompressor cable (3) at the decompressor valve lifter lever (4).
3. Be sure the piston is at the top of the compression stroke and the T mark is aligned with the index mark.

4. Measure the free play at the tip of the decompression lifter lever. To adjust, loosen the lock nut (5) and turn the adjusting nut (6).

Free play: 1—2 mm (1/32—1/16 in)

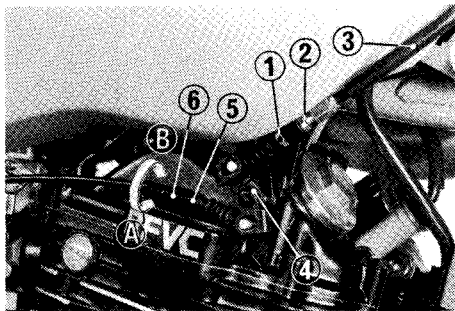

- (1) Decompressor adjusting nut
  - (2) Decompressor lock nut
  - (3) Manual decompressor cable
  - (4) Lifter lever
  - (5) Adjusting nut
  - (6) Lock nut
- (A) Increase free play  
(B) Decrease free play

5. Install all parts in the reverse order of disassembly.
6. Connect the manual decompressor cable to the lifter lever.
7. Measure the free play at the top of the manual decompressor lever (7).  
Free play: 5—8 mm (3/16—5/16 in)  
To adjust: Loosen the manual decompressor lock nut (2) and turn the adjusting nut (1).

#### Other Checks:

Check the decompression cable for kinks or signs of wear that could cause sticking or failure. Lubricate the decompression cable with a commercially available cable lubricant to prevent premature wear and corrosion.

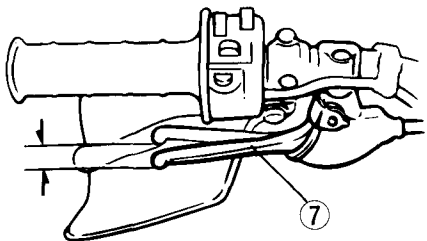

(7) Manual decompressor lever

## THROTTLE OPERATION

### Cable Inspection:

Check for smooth rotation of the throttle grip from the fully open to the fully closed position. Check at full left and full right steering positions. Inspect the condition of the throttle cables from the throttle grip down to the carburetor. If the cables are kinked, chafed or improperly routed, they should be replaced or rerouted.

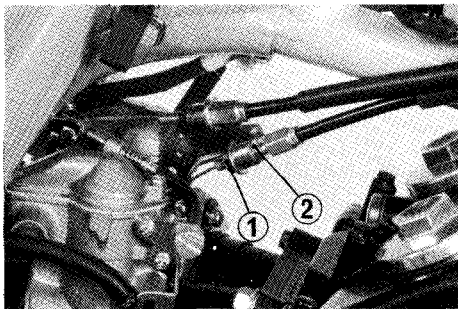

(1) Lower lock nut      (2) Lower adjuster

Check the cables for tension or stress at both full left and full right steering position. Lubricate the throttle cables with a commercially available cable lubricant to prevent premature wear and corrosion.

### **WARNING**

*\* For safe operation and positive engine response, the throttle cable must be properly adjusted.*

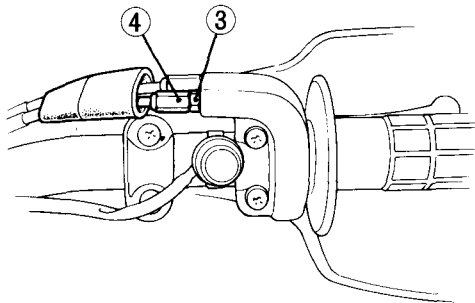

(3) Upper lock nut      (4) Upper adjuster

### Free Play Adjustment:

Standard throttle grip free play is approximately 2—6 mm (1/8—1/4 in) of grip rotation. Major free play adjustments, such as after replacing the throttle cables or removing the carburetor, are made with the lower adjuster (2). Minor free play adjustments are made with the upper adjuster (4). To adjust free play, loosen the lock nut (1) or (3), and turn the adjuster (2) or (4). Tighten the lock nut after adjustment.

## CARBURETOR

### Idle Speed:

#### NOTE:

- \* Do not attempt to compensate for faults in other systems by carburetor adjustment. See your authorized Honda dealer for regularly scheduled carburetor adjustments.
- \* The engine must be warm for accurate idle adjustment.

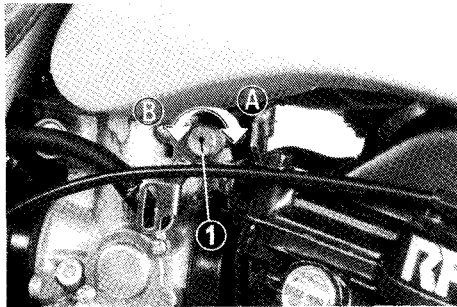

(1) Throttle stop screw (A) Increase rpm  
(B) Decrease rpm

1. Warm up the engine and hold the motorcycle upright. Shift to neutral.
2. Adjust the idle speed with the throttle stop screw (1).  
IDLE SPEED:  $1,300 \pm 100$  rpm

### Idle Mixture:

1. Turn the pilot screw clockwise until the engine misses or decreases in speed, then counterclockwise until the engine again misses or decreases in speed. Set the screw exactly between these two extreme positions to adjust the fuel mixture. Usually the correct setting will be found to be 1-1/2 turns open from the fully closed position.
2. If the idle speed changes after adjusting fuel mixture, readjust the idle speed by turning the throttle stop screw.

## CLUTCH

Clutch adjustment may be required if the motorcycle stalls when shifting into gear or tends to creep; or if the clutch slips, causing acceleration to lag behind engine speed.

Normal clutch lever free play is 10–20 mm (3/8–3/4 in) at the lever (1). Minor adjustments can be made with the clutch cable adjuster at the lever.

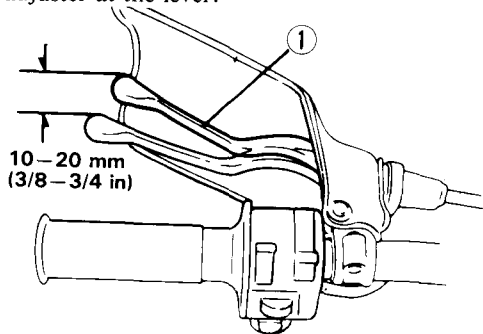

(1) Clutch lever

1. Pull back the rubber dust cover (2). Loosen the lock nut (3) and turn the adjuster (4). Tighten the lock nut and check the adjustment.
2. If the adjuster is threaded out near its limit or if the correct free play cannot be obtained, loosen the lock nut and turn in the cable adjuster completely. Tighten the lock nut and pull on the dust cover.

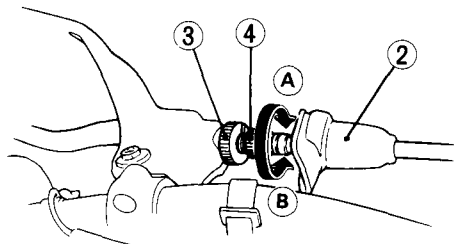

(2) Dust cover  
(3) Lock nut  
(4) Adjuster

(A) Increase free play  
(B) Decrease free play

3. At the middle part of the cable, loosen the lock nut (6). Turn the adjusting nut (5) to obtain the specified free play. Tighten the lock nut and check the adjustment.
4. Start the engine, pull in the clutch lever and shift into gear. Make sure the engine does not stall and the motorcycle does not creep. Gradually release the clutch lever and open the throttle. The motorcycle should start smoothly and accelerate gradually.

**NOTE:**

- \* If proper adjustment cannot be obtained or the clutch does not work correctly, the cable or clutch friction discs may be worn. Refer to the official Honda shop manual or see your authorized Honda dealer.

Other Checks:

Check the clutch cable for kinks or signs of wear that could cause sticking or failure. Lubricate the clutch cable with a commercially available cable lubricant to prevent premature wear and corrosion.

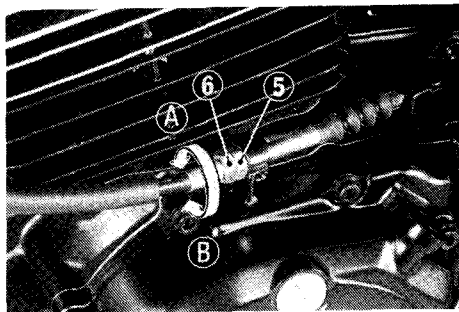

(5) Adjusting nut  
(6) Lock nut

(A) Increase free play  
(B) Decrease free play

## FRONT BRAKE

This model has a hydraulic disc front brake. As the brake pads wear, brake fluid level drops, automatically compensating for wear.

There are not adjustments to perform, but fluid level and pad wear must be inspected periodically. The system must be inspected frequently to ensure there are no fluid leaks. If the control lever free play becomes excessive and the brake pads are not worn beyond the recommended limit (page 81), there is probably air in the brake system and it must be bled. See your authorized Honda dealer.

### Brake Fluid Level:

#### **WARNING**

\* *Brake fluid may cause irritation. Avoid contact with skin or eyes. In case of contact, flush thoroughly with water and call a doctor if your eyes were exposed.*

Remove the screws, reservoir cap and diaphragm. Whenever the level is near the lower level mark (1) on the front reservoir, fill the reservoir with DOT 4 BRAKE FLUID from a sealed container. Reinstall the diaphragm and reservoir cap. Tighten the screws securely.

#### **CAUTION:**

\* *When adding brake fluid be sure the reservoir is horizontal before the cap is removed or brake fluid may spill out.*

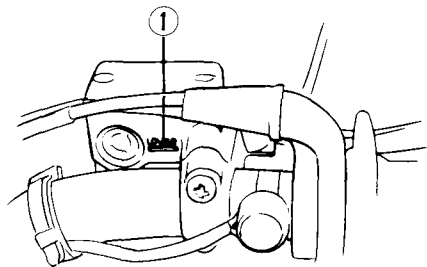

(1) Lower level mark

## CAUTION:

- \* Use only DOT 4 brake fluid from a sealed container.
- \* Handle brake fluid with care because it can damage paint and instrument lenses.
- \* Never allow contaminants (dirt, water, etc.) to enter the brake fluid reservoir.

### Front brake lever adjuster:

The front brake lever is provided with a free play adjuster. To increase free play, loosen the lock nut (2) and turn the adjuster (3) counterclockwise. To decrease free play, turn the adjuster clockwise.

### WARNING

- \* Never use the adjusters other than those designed for this motorcycle. Install a new adjuster from the lever side with the lock nut under the head of the adjuster.

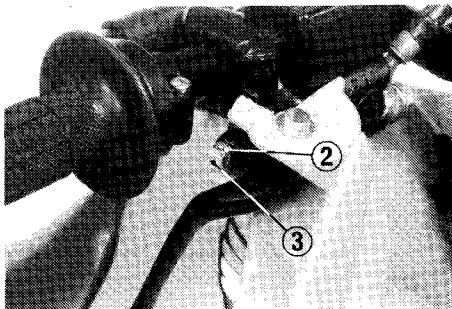

(2) Lock nut

(3) Adjuster

### Other Checks:

Make sure there are no fluid leaks. Check for deterioration or cracks in the hose and fittings.

## REAR BRAKE

### Adjustment:

1. Place the motorcycle on its side stand.
2. The stopper bolt (1) is provided to allow adjustment of the pedal height.  
To adjust the pedal height, loosen the lock nut (2) and turn the stopper bolt. Tighten the lock nut.

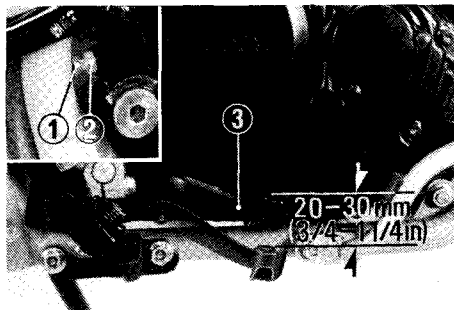

(1) Stopper bolt  
(2) Lock nut

(3) Rear brake pedal

3. Measure the distance the rear brake pedal (3) moves before the brake starts to take hold.

Free play should be 20—30 mm (3/4—1-1/4 in). If adjustment is necessary, turn the rear brake adjusting nut (4).

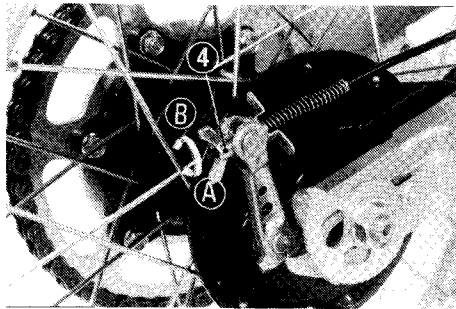

(4) Adjusting wing nut (A) Decrease free play  
(B) Increase free play

**NOTE:**

- \* Make sure the cut-out on the adjusting nut is seated on the brake arm pin.
  - \* If proper adjustment cannot be obtained by this method, the brake cable or brake shoes may be worn. Replace if necessary.
4. Apply the brake several times and check for free wheel rotation when released.

Other Checks:

Check the brake cable for kinks or signs of wear that could cause sticking or failure. Lubricate the brake cable with a commercially available cable lubricant to prevent premature wear and corrosion. Make sure the brake arm, spring and fasteners are in good condition.

## BRAKE WEAR INDICATORS

### Brake Pad Wear

Brake pad wear will depend upon the severity of usage, type of riding, and condition of the roads. The pads (1) will wear faster on dirty and wet roads. Inspect the pads visually from under the caliper during all regular service intervals to determine the pad wear. If either pad wears to the wear limit both pads must be replaced.

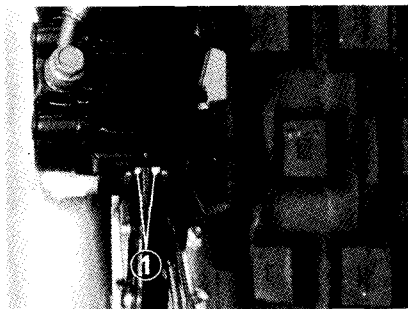

(1) Pads

### Brake Shoe Wear

The rear brake is equipped with brake wear indicators.

When the brake is applied, an arrow (1) attached to the brake arm (2) moves toward a reference mark (3) on the brake panel (4). If the arrow aligns with the reference mark on full application of the brake, the brake shoes must be replaced.

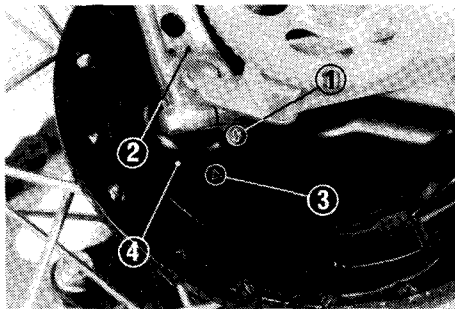

(1) Arrow  
(2) Brake arm

(3) Reference mark  
(4) Brake panel

## DRIVE CHAIN

The service life of the drive chain (1) is dependent upon proper lubrication and adjustment. Poor maintenance can cause premature wear or damage to the drive chain and sprockets.

The drive chain should be checked and lubricated as part of the Pre-ride Inspection (page 35). Under severe usage, or when the motorcycle is ridden in unusually dusty areas, more frequent maintenance will be necessary.

### Inspection:

1. Turn the engine off, raise the rear wheel off the ground by placing a support under the engine, and shift the transmission into neutral.
2. Check slack in the upper drive chain run midway between the sprockets. Drive chain slack should be adjusted to allow 35—45 mm (1-3/8—1-3/4 in) vertical movement by hand.

3. Rotate the wheel and check drive chain slack as the wheel turns. Drive chain slack should remain constant as the wheel rotates. If the chain is slack in one section and taut in another, some links are kinked and binding. Kinks and binding can frequently be eliminated by lubrication.

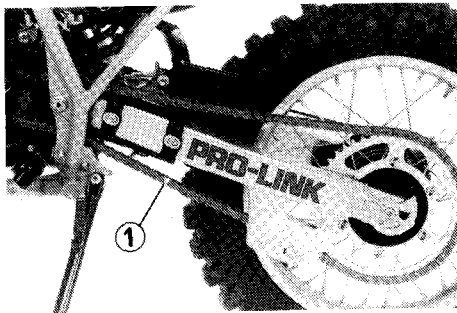

(1) Drive chain

4. Check the chain slipper (2) and chain guide slider (3) for wear.

If the distance from the bottom of the groove to the lower end of the chain slipper exceeds the limit, the chain slipper must be replaced. Chain slipper depth limit:

15 mm (0.6 in)

Replace the chain guide slider if the chain is visible through the wear inspection window.

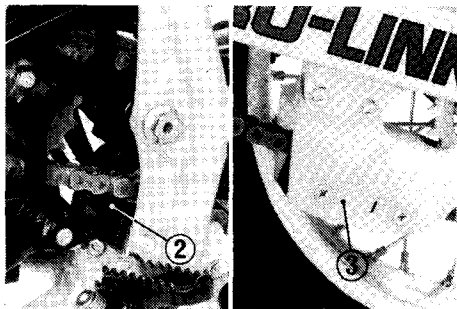

(2) Chain slipper

(3) Chain guide slider

5. Measure a section of the drive chain to determine whether the chain is worn beyond its service limit. Remove the drive chain and measure the distance between a span of 109 pins from pin center to pin center. In a new chain, this distance will measure 1,730 mm (68.1 in). If the distance exceeds 1,764 mm (69.4 in), the chain is worn out and should be replaced.

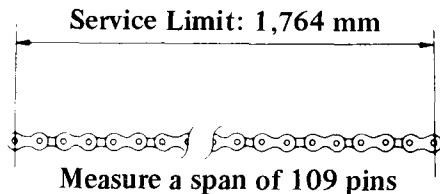

6. Inspect the sprocket teeth for wear or damage.

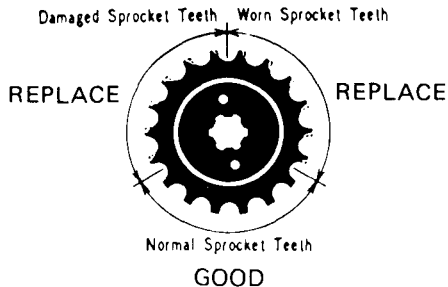

Standard sprocket sizes:

Drive sprocket (engine)	Driven sprocket (rear wheel)
14 teeth	48 teeth

**NOTE:**

\* If the drive chain or sprockets are excessively worn or damaged, they should be replaced. Never use a new chain with worn sprockets; rapid chain wear will result.

**Adjustment:**

If the drive chain requires adjustment, the procedure is as follows:

1. Loosen the rear axle nut (1) while holding the axle.
2. Loosen the stopper plate nuts (2).
3. Turn both right and left adjusters (3) equally to increase or decrease chain slack.

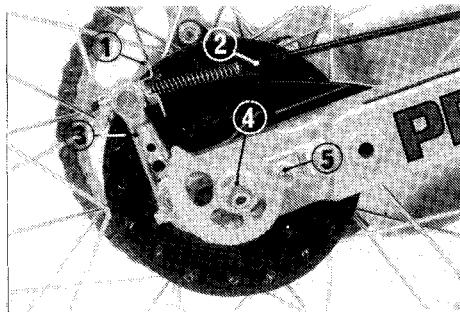

- (1) Axle nut                      (4) Stopper pin  
 (2) Stopper plate nuts        (5) Index mark  
 (3) Chain adjuster

4. After adjusting, be sure the same adjuster index marks (5) align with the pins (4) on both sides of the swingarm.

**NOTE:**

- \* If drive chain slack is excessive when the rear axle is moved to the furthest limit of adjustment, the drive chain is worn and must be replaced.
5. Tighten the stopper plate nuts to 25—35 N·m (2.5—3.5 kg-m, 18—25 ft-lb). Tighten the rear axle nut to 80—100 N·m (8.0—10.0 kg-m, 58—72 ft-lb) torque.
  6. Recheck chain slack.
  7. Rear brake pedal free travel is affected when repositioning the rear wheel to adjust drive chain slack. Check rear brake pedal free play and adjust as necessary (pages 66—67).

Lubrication and cleaning:

Lubricate every 300 miles (500 km) or sooner if chain appears dry.

The O-rings in this chain can be damaged by steam cleaning, high pressure washers, and certain solvents. Clean the chain with kerosene. Wipe dry and lubricate only with SAE 80 or 90 gear oil. Commercial chain lubricants may contain solvents which could damage the rubber O-rings. Replacement Chain. RK520 MO, DID 520 VC-6

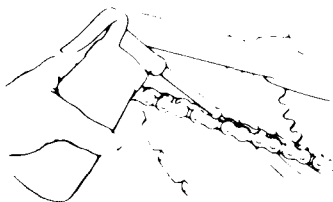

## Removal and Cleaning:

When the drive chain becomes dirty, it should be removed and cleaned prior to lubrication.

1. Carefully remove the master link retaining clip with a pliers. Do not bend or twist the clip. Remove the master link. Remove the drive chain from the motorcycle.
2. Clean the drive chain in clean nonflammable or high flash point solvent and allow to dry. Inspect the drive chain and clip for possible wear or damage. Replace any chain that has damaged rollers, loose fitting links, or otherwise appears unserviceable.

### WARNING

- \* *Never use gasoline or low flash point solvents for cleaning the drive chain. A fire or explosion could result.*
3. Inspect the sprocket teeth for possible wear or damage. Replace if necessary.
  4. Lubricate the drive chain (see page 72).
  5. Pass the chain over the sprockets and join the ends of the chain with the master link. For ease of assembly, hold the

chain ends against the rear sprocket teeth while inserting the master link.

- Install the master link retaining clip (1) so that the closed end of the clip will face the direction of forward wheel rotation. The master link is the most critical part affecting the security of the drive chain. It is recommended that a new master link retaining clip be installed whenever the drive chain is reassembled.
6. Adjust the drive chain and rear brake pedal free play.

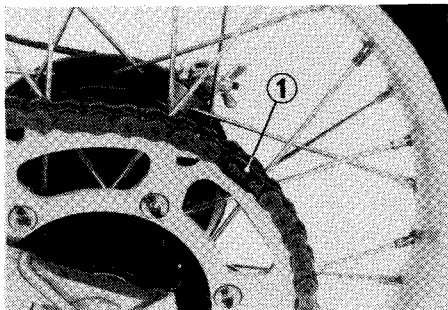

(1) Retaining clip

## FRONT WHEEL REMOVAL

1. Raise the front wheel off the ground by placing a support under the engine.
2. Remove the speedometer cable set screw (1) and disconnect the speedometer cable (2).
3. Remove the front axle holder nuts (3) and the front axle holder (4).
4. Unscrew the axle (5). Remove the wheel.

### NOTE:

\* Do not depress the brake lever when the wheel is off the motorcycle. The caliper piston will be forced out of the cylinder with subsequent loss of brake fluid. If this occurs, servicing of the brake system will be necessary. See your authorized Honda dealer.

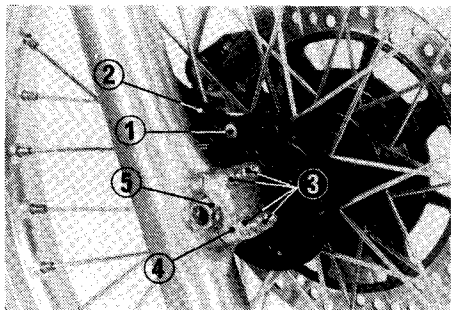

- |                       |                 |
|-----------------------|-----------------|
| (1) Screw             | (4) Axle holder |
| (2) Speedometer cable | (5) Axle        |
| (3) Axle holder nuts  |                 |

### Installation Notes:

- Reverse the removal procedure.
- Insert the axle through the wheel hub and left fork leg.

Make sure that the tang (6) on the fork leg is located in the slot (7) in the brake panel.

- Tighten the axle.

Axle torque:

50—80 N·m (5.0—8.0 kg-m,  
36—58 ft-lb)

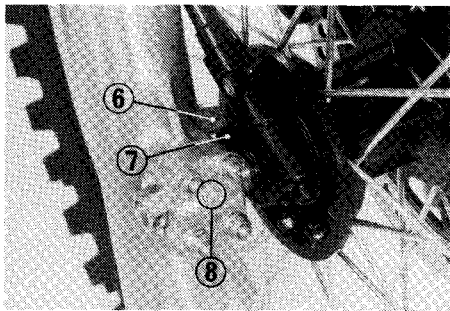

(6) Tang

(7) Slot

(8) UP mark

- Install the axle holder with the UP mark (8) upward and tighten the upper holder nuts to the specified torque first, then tighten the lower holder nuts to the same torque.

Axle holder nut torque:

10—14 N·m (1.0—1.4 kg-m,  
7—10 ft-lb)

- After installing the wheel, apply the brake several times and check for free wheel rotation when released.

### WARNING

- \* *If a torque wrench was not used for installation, see your dealer as soon as possible to verify proper assembly.*

## REAR WHEEL REMOVAL

1. Raise the rear wheel off the ground by  
• placing a support under the engine.
2. Pull the brake arm pin holder (1) forward and lift the brake rod (2) up to disconnect it from the rear brake arm (3).
3. Loosen the rear axle nut (4) while holding the axle.
4. Loosen the stopper plate nuts (5).
5. Turn both adjusters so the rear wheel can be moved all the way forward for maximum drive chain slack.
6. Move the rear wheel forward. Deraill the drive chain from the driven sprocket.
7. Remove the rear wheel with the rear axle.

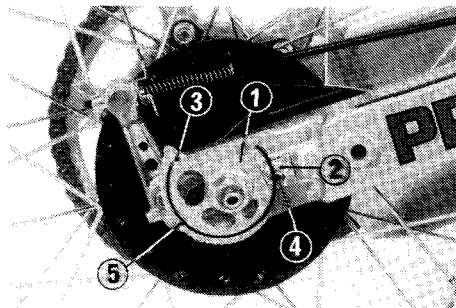

- |                          |                       |
|--------------------------|-----------------------|
| (1) Brake arm pin holder | (4) Axle nut          |
| (2) Brake rod            | (5) Stopper plate nut |
| (3) Brake arm            |                       |

### Installation Note:

- To install the rear wheel, reverse the removal procedure.
- Make sure that the tang (6) on the swingarm is located in the slot (7) in the brake panel (8).
- Torque the following bolts:  
Axle nut torque  
80—100 N·m (8.0—10.0 kg·m,  
58—72 ft·lb)  
Stopper plate nuts  
25—35 N·m (2.5—3.5 kg·m, 18—25  
ft·lb)

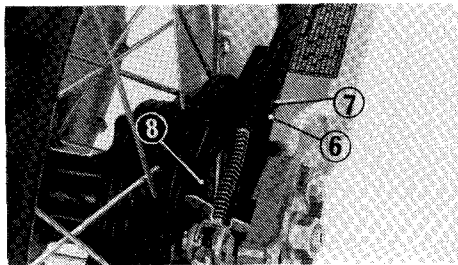

(6) Tang (7) Slot (8) Brake panel

- Position the brake arm pin holder (9) correctly.
- Adjust the rear brake (pages 66—67) and drive chain (pages 71—72).
- Apply the brake several times and check for free wheel rotation when released.

### WARNING

- \* *If a torque wrench was not used for installation, see your dealer as soon as possible to verify proper assembly.*

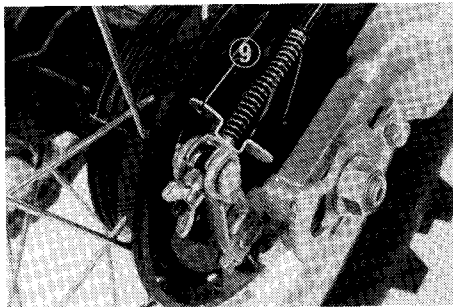

(9) Brake arm pin holder

## FRONT SUSPENSION

Check front fork action by locking the front brake and pumping the forks up and down several times. The suspension should function smoothly, with no oil leakage from the fork legs. Damaged, binding, or leaking front forks should be repaired before the motorcycle is operated. Check security of all front fork and handlebar mounting bolts (1).

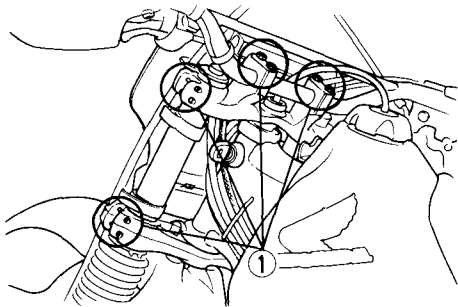

(1) Mounting bolts

### WARNING

- \* *If any suspension components appear worn or damaged, consult your Honda dealer for further inspection. The suspension components are directly related to safety and your Honda dealer is qualified to determine whether or not replacement parts or repairs are needed.*
- \* *Do not operate the motorcycle with loose, worn, or damaged steering or front suspension components, as handling will be adversely affected.*

## REAR SUSPENSION

Check the rear suspension periodically by careful visual examination. Note the following items.

1. Swingarm bearings should be checked by pushing hard against the side of the rear wheel. Free play indicates worn bearings.
2. Check all suspension component attaching points for security of their respective fasteners.
3. Check for oil leaks in the shock absorber units.

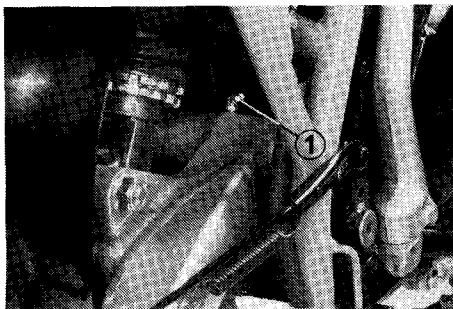

(1) Swingarm pivot

### NOTE:

- \* If any of the before mentioned components appear damaged or worn, consult your Honda dealer for further inspection.

### Lubrication:

There are grease fittings at the swingarm pivot (1) and suspension linkage pivots (2). The swingarm pivot and linkage should be lubricated at the specified intervals with lithium based multipurpose grease with molybdenum disulfide additive.

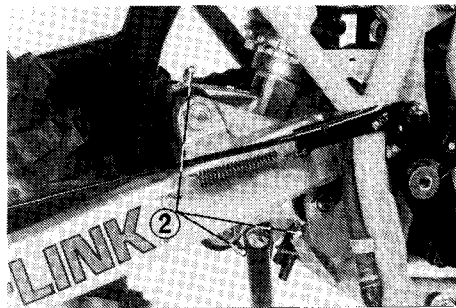

(2) Suspension linkage pivots

## SIDE STAND

Check the side stand spring (1) for damage and loss of tension, and the side stand assembly for freedom of movement. If the side stand is squeakily or stiff, clean the pivot area and lubricate the pivot bolt with engine oil.

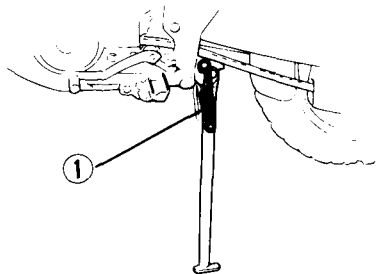

(1) Side stand spring

Check the rubber pad for deterioration and wear. Replace if wear extends to the wear line (2) as shown. Check the side stand spring for damage and loss of tension, and the side stand assembly for freedom of movement. See your authorized Honda dealer for replacement.

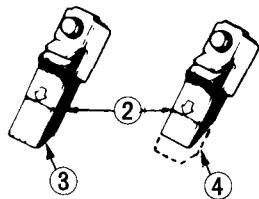

(2) Wear line    (4) Replace  
(3) Good

## WHEEL RIMS AND SPOKES

1. Inspect the wheel rims (1) and spokes (2) for damage.
2. Tighten any loose spokes and rim locks (3).
3. Check wheel rim runout. If runout is noticeable, see your Honda dealer for inspection.

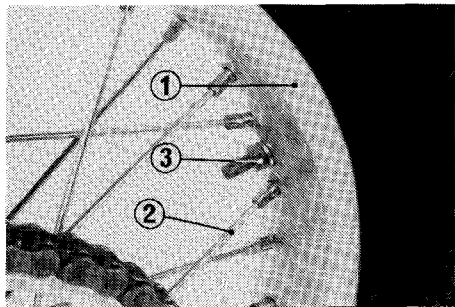

(1) Wheel rim  
(2) Spoke

(3) Rim lock

### WARNING

- \* *Maintenance of spoke tension and wheel trueness are critical to safe motorcycle operation. During the first 200 miles (350 km), spokes will loosen more rapidly due to initial seating of parts. Excessively loose spokes may result in high speed instability and possible loss of control.*

## HEADLIGHT AND TAILLIGHT

### Headlight Bulb:

1. Remove the three headlight mounting bands (1) and remove the front number plate (2).
2. Disengage socket from headlight (3).
3. Remove the bulb (4) with a new one.

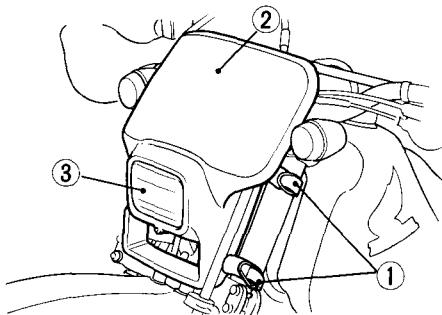

- (1) Headlight mounting bands  
(2) Number plate  
(3) Headlight

4. To install the headlight, reverse the removal procedure.

### NOTE:

- \* When installing the bulb, align the tab on the bulb with the groove on the headlight case.

### Headlight Aim:

The headlight beam can be raised or lowered. Turn the adjusting screw (6) to move the headlight up or down to the proper adjustment.

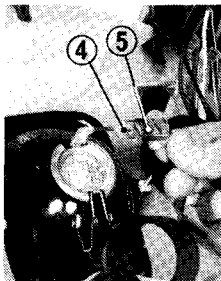

- (4) Headlight bulb  
(5) Socket



- (6) Adjusting screw

### Taillight Bulb Replacement:

1. Remove the two screws (7) and remove the taillight lens (8).
2. Replace the bulb (9) with a new one.
3. Reinstall the lens.

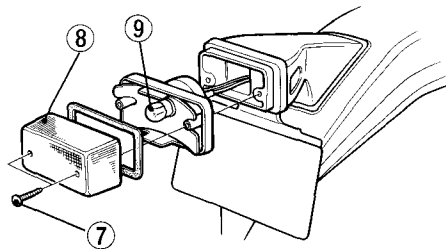

(7) Screws (8) Taillight lens (9) Taillight bulb

### **STOPLIGHT SWITCH**

Check the operation of the stoplight switch (1) at the right side behind the engine from time to time.

Adjustment is done by turning the adjusting nut (2).

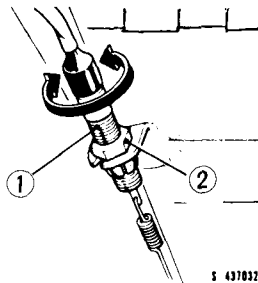

(1) Stoplight switch (2) Adjusting nut

## TURN SIGNAL

### Turn Signal Bulb

1. Remove the turn signal light lens (1) by pulling it forward.
2. Press the bulb (2) inward and twist to the left and the bulb can be removed.
3. Replace with a new bulb.
4. Install the turn signal light lens by pressing it.

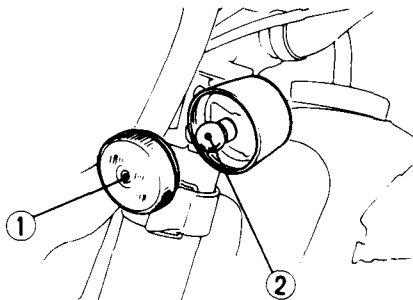

- (1) Turn signal light lens  
(2) Bulb

### Turn Signal Removal

When you ride your XR600R with the signals removed, observe the following to prevent entry of mud and water into the connectors:

- Front turn signals/ – Wrap the wire harness connector with a tape.  
Rear turn signals

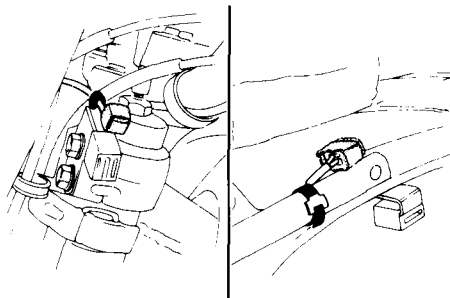

## CLEANING

Clean your motorcycle regularly to protect the surface finishes and inspect for damage, wear, and oil or hydraulic fluid seepage.

### CAUTION:

- \* *Avoid spraying high pressure water (typical in coin-operated car washes) at the following areas:*

*Wheel Hubs*

*Carburetors      Brake Master Cylinder*

*Instruments      Muffler Outlet*

*Under Seat      Under Fuel Tank*

*Drive Chain*

1. After cleaning, rinse the motorcycle thoroughly with plenty of clean water. Strong detergent residue can corrode alloy parts.

2. Dry the motorcycle, start the engine, and let it run for several minutes.



### WARNING

- \* *Braking performance may be impaired immediately after washing the motorcycle.*
3. Test the brakes before riding the motorcycle. Several applications may be necessary to restore normal braking performance.
  4. Lubricate the drive chain immediately after washing the motorcycle.

## STORAGE GUIDE

### STORAGE

Extended storage, such as for winter, requires that you take certain steps to reduce the effects of deterioration from non-use of the motorcycle. In addition, necessary repairs should be made **BEFORE** storing the motorcycle; otherwise, these repairs may be forgotten by the time the motorcycle is removed from storage.

1. Change the engine oil and filter.
2. Lubricate the drive chain.
3. Drain the fuel tank and carburetor.  
Reinstall the fuel cap on the tank.



#### WARNING

- \* *Gasoline is flammable and is explosive under certain conditions. Do not smoke or allow flames or sparks near the equipment while draining fuel.*

4. Remove the spark plug and pour a tablespoon (15—20 cc) of clean engine oil into the cylinder. Crank the engine several times to distribute the oil, then reinstall the spark plugs.

#### NOTE:

- \* When turning the engine over, the Engine Stop button should be pushed and the spark plug placed in its cable cap and grounded to prevent damage to the ignition system.
5. Wash and dry the motorcycle. Wax all painted surfaces.

7. Inflate the tires to their recommended pressures. Place the motorcycle on blocks to raise both tires off the ground.
8. Cover the motorcycle (don't use plastic or other coated materials) and store in an unheated area, free of dampness with a minimum of daily temperature variation. Do not store the motorcycle in direct sunlight.

## **REMOVAL FROM STORAGE**

1. Uncover and clean the motorcycle. Change the engine oil if more than 4 months have passed since the start of storage.
2. Fill the fuel tank with fresh gasoline.
3. Perform all Pre-ride Inspection checks (page 35). Test ride the motorcycle at low speeds in a safe riding area away from traffic.

## **SPECIFICATIONS**

### **DIMENSIONS**

Overall length	2,145 mm (84.4 in)
Overall width	910 mm (35.8 in)
Overall height	1,205 mm (47.4 in)
Wheel base	1,450 mm (57.1 in)

### **WEIGHT**

Dry weight	121 kg (267 lbs)
------------	------------------

### **CAPACITIES**

Engine oil	2.3 ℓ (2.4 US qt) After disassembly 1.9 ℓ (2.0 US qt) After draining 1.95 ℓ (2.1 US qt) After draining and oil filter change
Fuel tank	10.5 ℓ (2.8 US gal)
Fuel reserve tank	3.0 ℓ (0.8 US gal)
Passenger capacity	Operator Only
Vehicle capacity load	100 kg (220 lbs)
Front fork oil capacity	631 cc (21.3 oz)
Front fork air pressure	0 psi (0 kPa, kg/cm <sup>2</sup> )

## ENGINE

Bore and stroke	97 x 80 mm (3.8 x 3.1 in)
Compression ratio	9.0 : 1
Displacement	591 cc (36.1 cu.in)
Spark plug	
Standard	DPR8EA-9 (NGK) or X24EPR-U9 (ND)
For cold climate	DPR7EA-9 (NGK) or X22EPR-U9 (ND)
Spark plug gap	0.8—0.9 mm (0.031—0.035 in)
Valve clearance	Intake: 0.10 mm (0.004 in) Exhaust: 0.12 mm (0.005 in)
Idle speed	1,300 ± 100 rpm

## CHASSIS AND SUSPENSION

Caster	62°
Trail	118 mm (4.6 in)
Tire size, front	3.00—21—6PR
Tire size, rear	5.10—17—6PR
Tire pressure, front	15 psi (100 kPa, 1.0 kg/cm <sup>2</sup> )
Tire pressure, rear	15 psi (100 kPa, 1.0 kg/cm <sup>2</sup> )

## POWER TRANSMISSION

Primary reduction	2.188
Final reduction	3.428
Gear ratio, 1st	2.384
2nd	1.647
3rd	1.250
4th	1.000
5th	0.840

## ELECTRICAL

Alternator	0.15 kW/5,000 rpm
------------	-------------------

## LIGHTS

Headlight (Low/High)	12V—25/25W
Taillight/Stop light	12V—18/5W
Turn signal light (Front/Rear)	12V—10/10W

## **NOISE EMISSION (AUSTRALIA ONLY)**

This motorcycle complies with the Australian Design Rule (ADR 39-2-3) requirements for noise emission regulations. And the data below are written according to the requirements.

Sound Level of Stationary Test	Engine Speed at Maximum Power
89 dB (A)	6,500 rpm

# MEMO