

HONDA®

Rotary Mower

HR21

OWNER'S
MANUAL

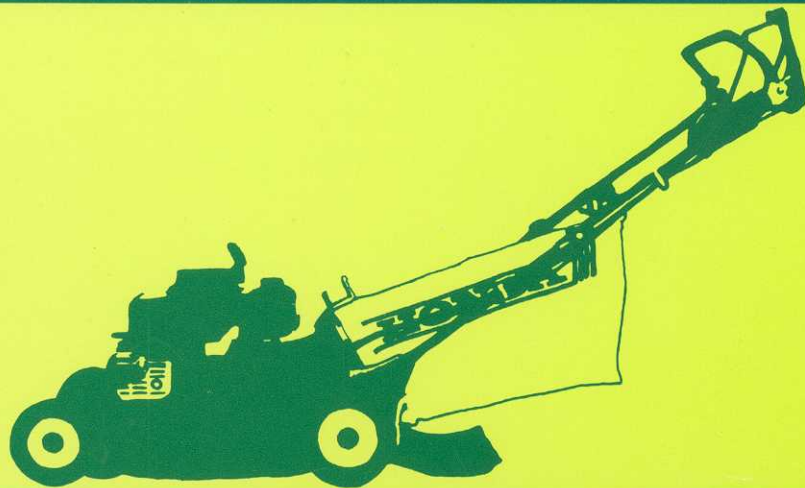
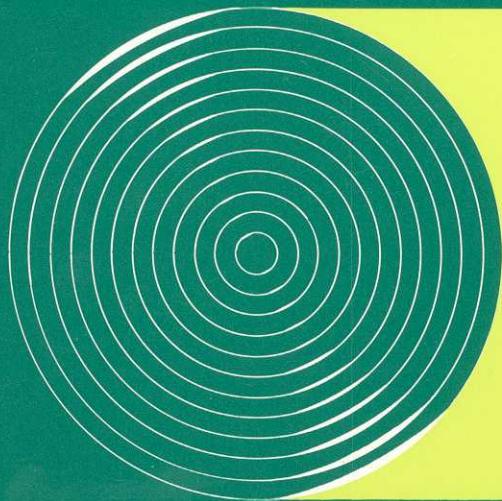

This HR21K2 meets C.P.S.C. blade safety requirement for walk behind rotary power mowers.

This manual covers operation and maintenance of the HONDA ROTARY MOWER HR21.

All information in this publication is based on the latest product information available at the time of approval for printing. Honda Motor Co., Ltd. reserves the right to make changes at any time without notice and without incurring any obligation.

Any powered product can be a potential source of danger if misused or improperly maintained.

Pay particular attention to statements preceded by the following words:

WARNING

Indicates the possibility of personal injury or loss of life if instructions are not followed.

CAUTION

Indicates the possibility of equipment damage if instructions are not followed.

Thank you for purchasing a Honda Lawn Mower.

If any problems occur, or if there are any questions concerning the mower, consult an authorized HONDA dealer.

No part of this publication may be reproduced without written permission.

WARNING

The Honda rotary mower is designed to give safe and dependable service if operated according to instructions and intended use: mowing (cutting) grass, and bagging cut grass when equipped with the grass bag. Any other use could be dangerous.

Read and understand the Owner's Manual before operating the mower. Failure to do so could result in personal injury or equipment damage.

CONTENTS	3
GENERAL SAFETY	4
COMPONENT IDENTIFICATION	5
THE CONTROLS	7
OPERATION	9
TRANSPORTING/STORAGE	18
MAINTENANCE	21
TROUBLESHOOTING	34
SPECIFICATIONS	35

GENERAL SAFETY

WARNING

- * *Know how to stop the engine quickly and understand operation of all the controls. Never permit anyone to operate the mower without proper instruction.*
 - * *The safety shield and side guard are for your protection; keep them in place at all times.*
 - * *The blade is sharp and dangerous. Never put your hands or feet under the mower. Never tilt the mower to expose the blade while the engine is running. If you find it necessary to work on the blade or mower, stop the engine and remove the spark plug cap.*
 - * *Never stand in front of self-propelled mowers when the engine is running. Someone may accidentally engage the drive clutch.*
 - * *Keep clear of the discharge opening when the bag is not attached to avoid being hit by a flying object.*
Clear the lawn of sticks, stones, or debris before mowing. Mow only in cleared areas in daylight or good artificial light.
- * *Protect yourself by wearing long trousers and appropriate shoes. Don't wear loose fitting clothing or sandals when mowing.*
 - * *Keep children and pets away from the mower at all times.*
 - * *If the blade strike a stone, sprinkler head, etc., be sure the blade, blade holder, woodruffkey, fasteners, crankshaft, etc. are in good condition before continuing to mow.*
Replace any damaged parts.

COMPONENT IDENTIFICATION

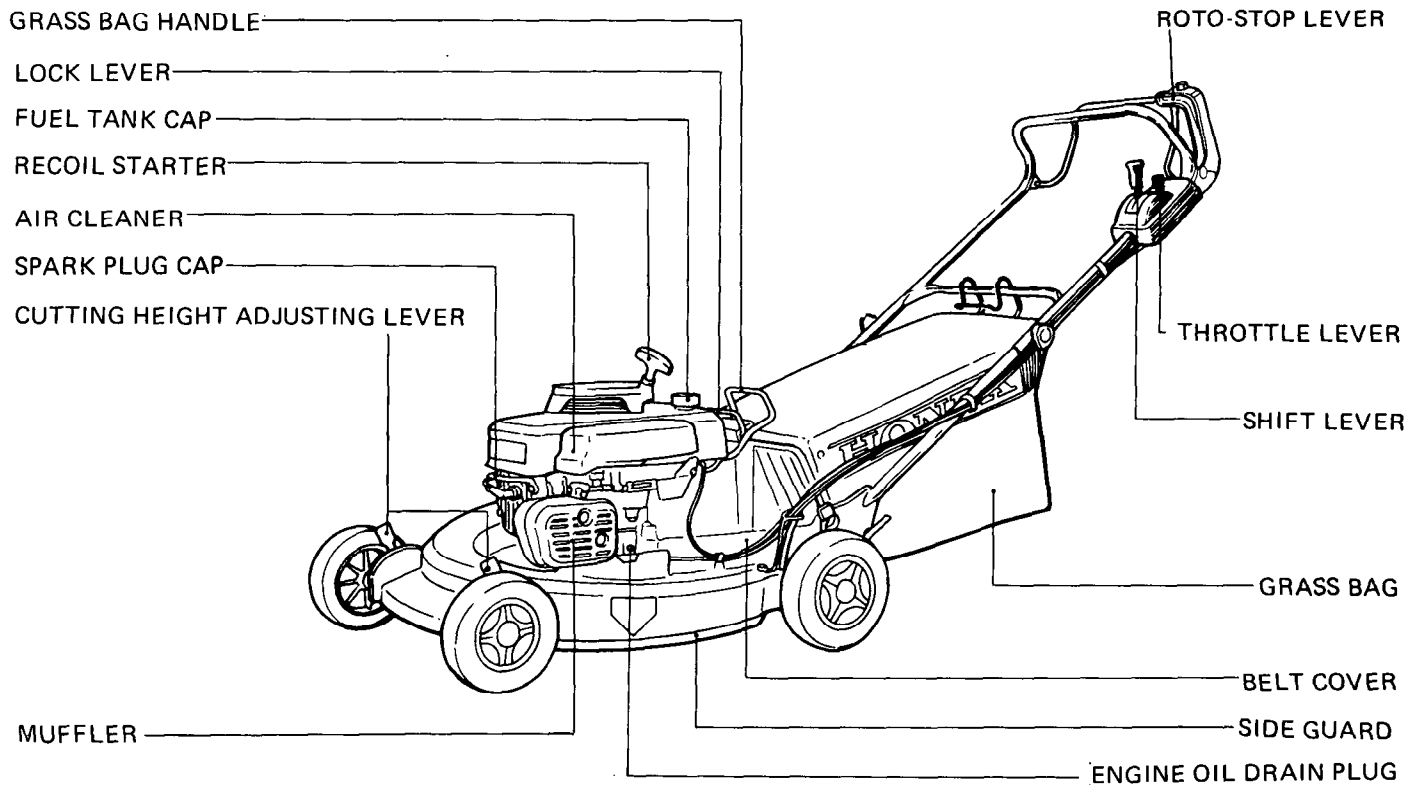

S-XAM type

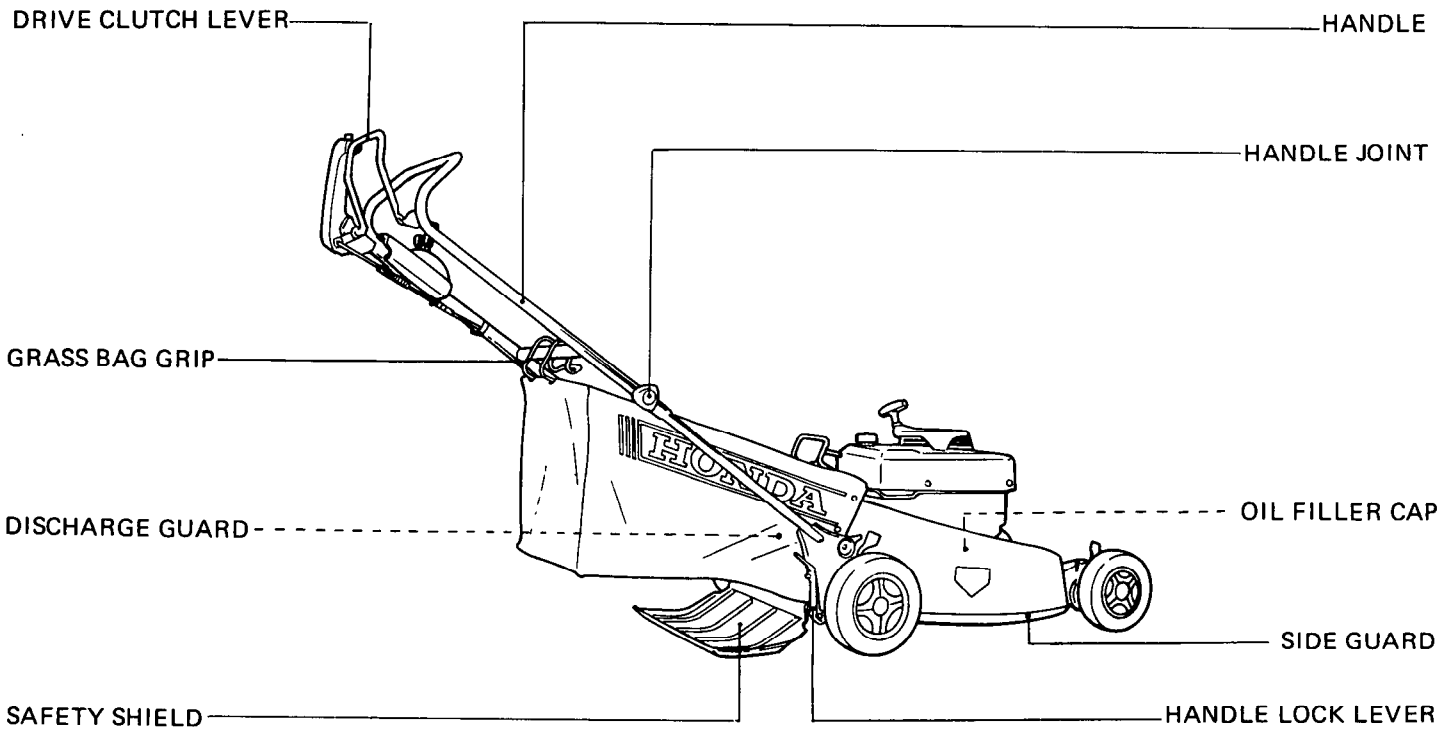

S-XAM type

THE CONTROLS

1. Throttle
“CHOKE”
“HI”
“LO”
“IDLE”
“STOP”

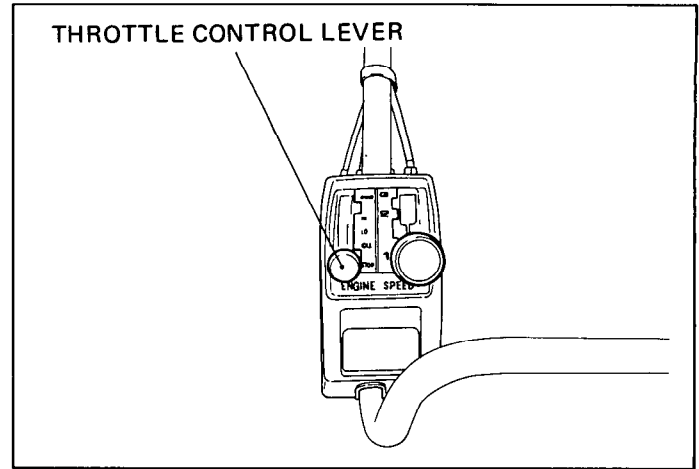

2. ROTO-STOP

To put the cutting blade into operation, press the button on top of the ROTO-STOP lever and push the lever forward, holding it against the handlebar. The blade will stop when the ROTO-STOP lever is released.

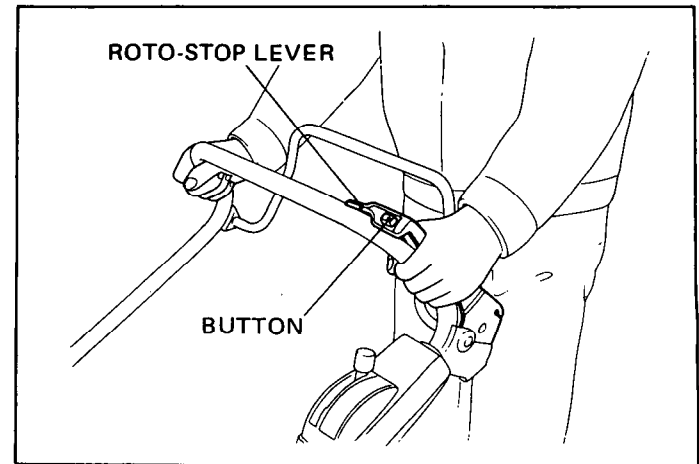

3. Drive Clutch (S-XAM TYPE only)

For self-propelled operation, push the drive clutch lever forward and hold it against the handlebar.

The drive clutch lever holds the ROTO-STOP lever forward during self-propelled operation. The button on top of the ROTO-STOP lever must be pressed before either of these levers can be moved forward – the cutting blade must be put into operation whenever the mower is to be self-propelled.

When the drive clutch is released, the drive is disengaged and the ROTO-STOP lever is released.

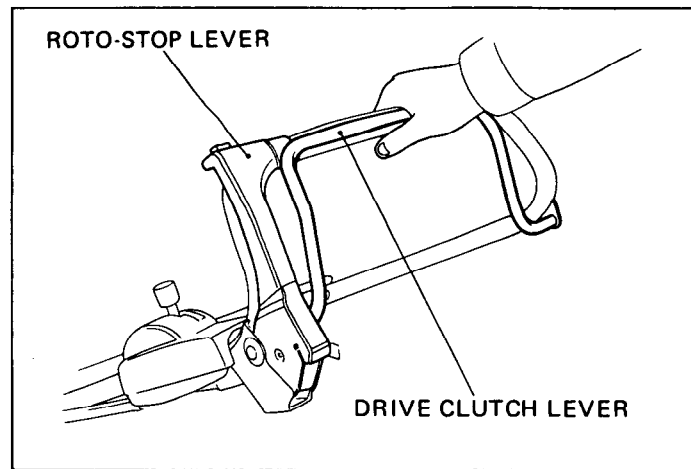

4. Shift Lever (S-XAM TYPE only)

Three forward speeds are available:

Position 1: Low, 0.8 m/sec (2.6 ft/sec)

Position 2: Medium, 1.0 m/sec (3.3 ft/sec)

Position 3: High, 1.2 m/sec (4.0 ft/sec)

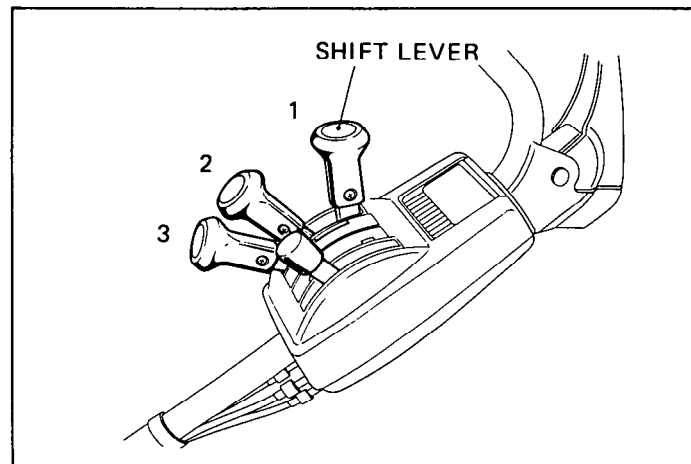

OPERATION

The HR21 may be used either with the grass bag, or without the bag as a mulching mower.

The following suggestions and rules are intended to help you operate your Honda HR21 under the safest conditions possible. Be alert and exercise the same care using the mower as you would using any other power tool.

WARNING

- * *Be especially careful when mowing uneven or rough ground. The mower may tilt, exposing the blade, and hidden objects could be thrown by the blade. Keep all four wheels on the ground.*

CAUTION

- * *Use extra care when mowing around objects to keep the blade from striking them. Never deliberately mow over any object.*
- * *Stop the engine immediately if the blade hits an object or the mower starts to vibrate. Remove the spark plug cap (keep the wire away from the plug) and inspect for damage.*

NOTE:

- Mow across slopes. Do not mow excessively steep slopes.
- Always push, never pull, a mower with the engine running. Control direction by the handle, not by foot pressure on the mower housing.
- Keep a firm hold on the handle and walk, never run, with the mower. Don't lag behind the machine or let it pull you.
- (S-XAM TYPE) Do not use the drive clutch when maneuvering around trees, etc. Release the clutch and push the mower while using the ROTO-STOP for better directional control.

BEFORE YOU START THE MOWER

1. Check the engine oil level.

CAUTION

- * Engine oil is a major factor affecting engine performance and service life. Non-detergent or vegetable oils are not recommended.
- * Running the engine with insufficient oil can cause serious engine damage.

Use Honda-4-stroke, or an equivalent high detergent, premium quality motor oil certified to meet or exceed U.S. automobile manufacturers' requirements for service classification SE or SF. (Motor oils classified SE or SF will show this designation on the container.) SAE 10W-40 is recommended for general, all temperature use. If single viscosity oil is used, select the appropriate viscosity for the average temperature in your area.

- With the mower on a level surface, remove the oil filler cap/dipstick using a screwdriver as illustrated.
- If the level is low, add the recommended oil to the "Upper" mark on the dipstick. Do not overfill; excess oil will result in power loss and smoking.

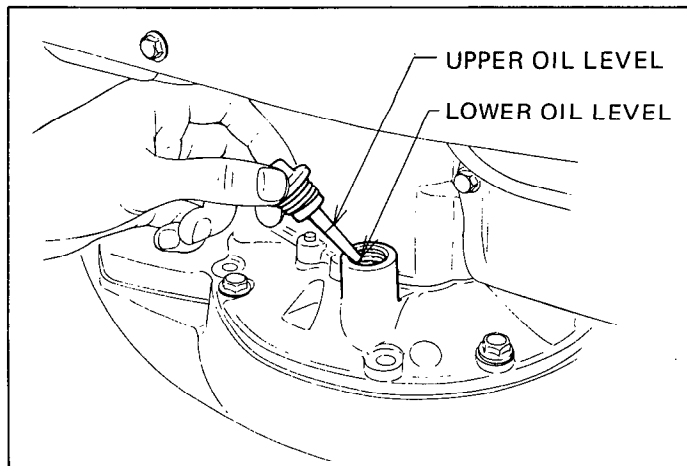
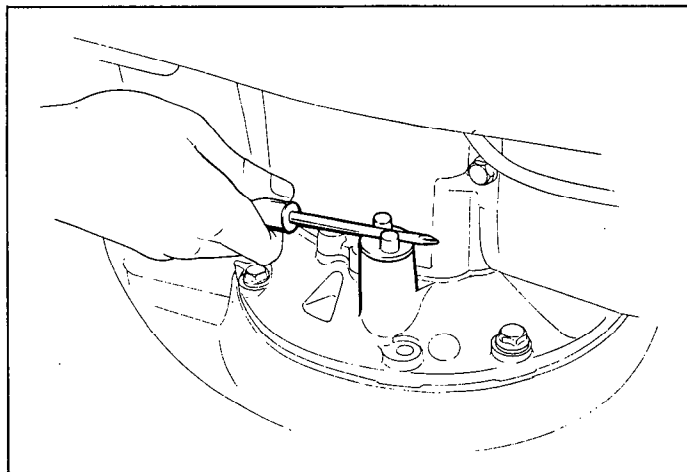
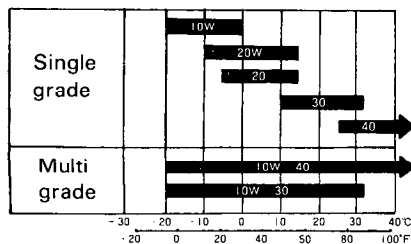

2. Check the fuel level.

Use automotive gasoline.

Never use an oil/gasoline mixture or dirty gasoline.

Avoid getting dirt, dust or water in the fuel tank.

WARNING

- * *Gasoline is extremely flammable and explosive under certain conditions. Refuel in a well ventilated area with the engine stopped.*
- * *Do not smoke or allow flames or sparks in the area where the mower is refueled or where gasoline is stored.*
- * *Be careful not to spill fuel when refueling. Fuel vapor or spilled fuel may ignite. Make sure the area is dry before starting the engine.*
- * *Do not overfill the tank and make sure the filler cap is securely closed after refueling.*
- * *Replenish when the engine is cold.*

CAUTION: Gasoline substitutes, such as gasohol etc., are not recommended, they may be harmful to the fuel system components.

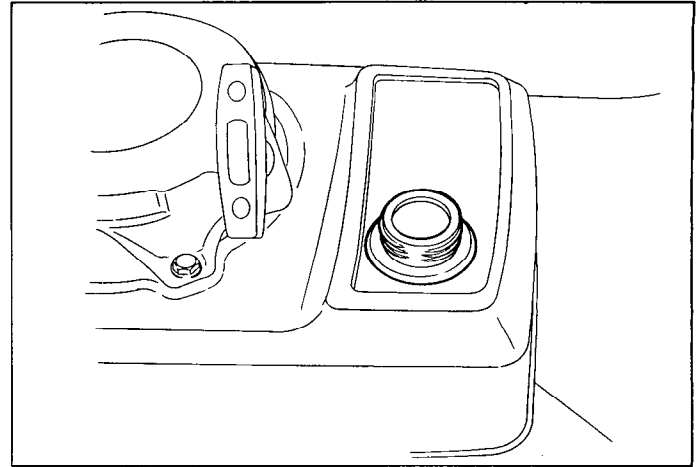

3. Check the grass bag for fraying, tears and clogged mesh. Wash the bag with water if necessary, and let it dry thoroughly. Grass will not chute properly without adequate ventilation through the bag. Make sure the lock lever is latched securely.
4. Check the blade bolts for tightness.
Torque: 4.5-5.5 kg m (32.5-39.8 ft lb)

WARNING

- * *To be certain that the engine will not start accidentally, remove the spark plug cap before performing this inspection.*
5. Check and clean the air cleaner element if it is dirty (p. 24).

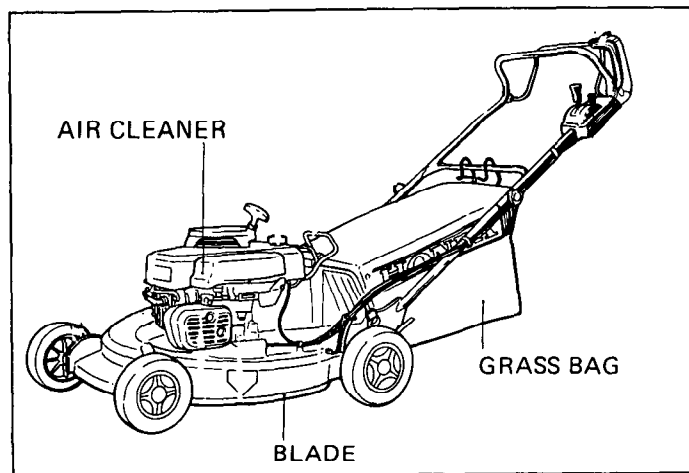

STARTING THE ENGINE

WARNING

* *Exhaust gas contains poisonous carbon monoxide. Never run the mower in an enclosed area. Be sure to provide adequate ventilation.*

1. Move the throttle lever to "CHOKE".

NOTE:

Do not use "CHOKE" when the engine is warm or the air temperature is high. Move the throttle to "LO" instead.

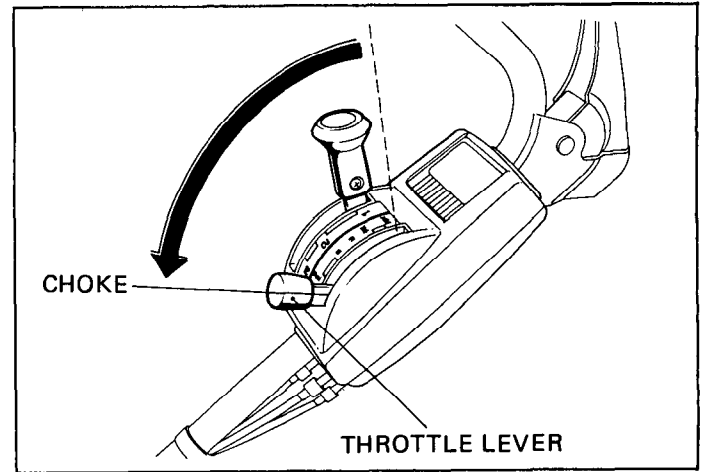

2. Turn the fuel valve "ON".

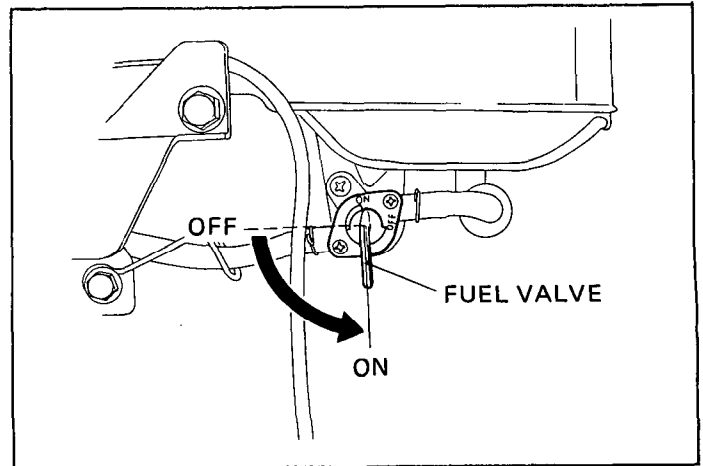

3. Place your foot on “STEP” on the mower housing.
4. Pull the starter rope lightly until you feel compression, then pull briskly.

NOTE:

Do not allow the rope to snap back; return it by hand.

5. After the engine warms up, move the throttle lever to “HI”. Squeeze the ROTO-STOP to start the blade.

(S-XAM TYPE) Move the shift lever to “1”. Engage the drive clutch/ROTO-STOP and the mower will move forward. For faster speeds, shift to “2” or “3”.

NOTE:

The throttle lever may be moved anywhere between “HI” and “LO” to adjust engine speed during operation.

However the engine may stall if the lever is at “IDLE” when the ROTO-STOP is engaged.

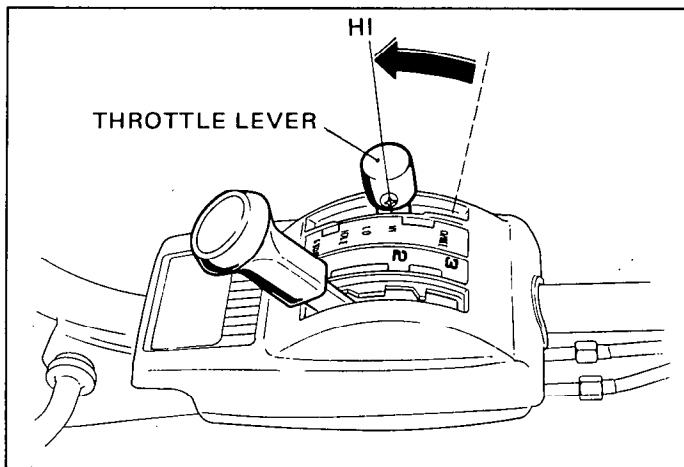
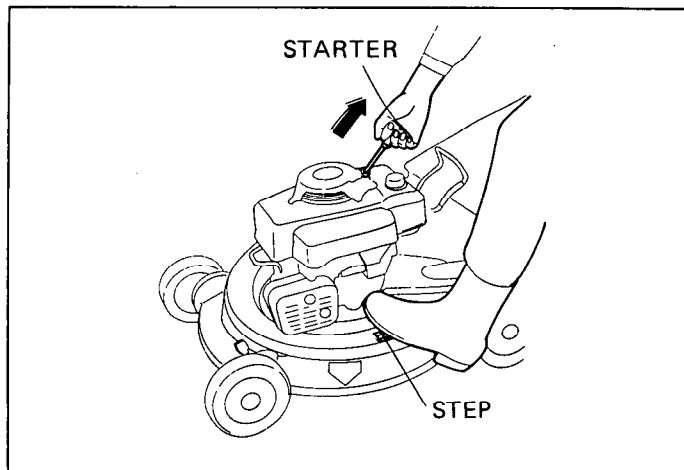

Flooded Engine

If the engine won't start after several pulls on the starter rope the engine is probably flooded.

To clear a flooded engine:

1. Move the throttle lever to "STOP" and turn off the fuel valve.
2. Remove and dry the spark plug. When re-installing the plug, thread it in by hand until it seats. Then tighten it an additional 1/8-1/4 turn with the spark plug wrench to compress the washer.
3. Move the throttle to "HI", turn on the fuel valve and repeat steps 3-5 under "Starting the Engine".

Stopping the Engine

1. Release the drive clutch (S-XAM TYPE only).
2. Move the throttle lever to "STOP" and turn off the fuel valve.

● High altitude operation

At high altitude, the standard carburetor air-fuel mixture will be excessively rich. Performance will decrease, and fuel consumption will increase.

High altitude performance can be improved by installing a smaller diameter main fuel jet in the carburetor and readjusting the pilot screw. If you always operate the rotary mower at altitudes higher than 6,000 feet above sea level, have your authorized

Honda Rotary Mower dealer perform these carburetor modifications.

Even with suitable carburetor jetting, engine horsepower will decrease approximately 3.5% for each 1,000 foot increase in altitude. The affect of altitude on horsepower will be greater than this if no carburetor modification is made.

CAUTION

* *Operation of the mower at an altitude lower than the carburetor is jetted for may result in reduced performance, overheating, and serious engine damage caused by an excessively lean air/fuel mixture.*

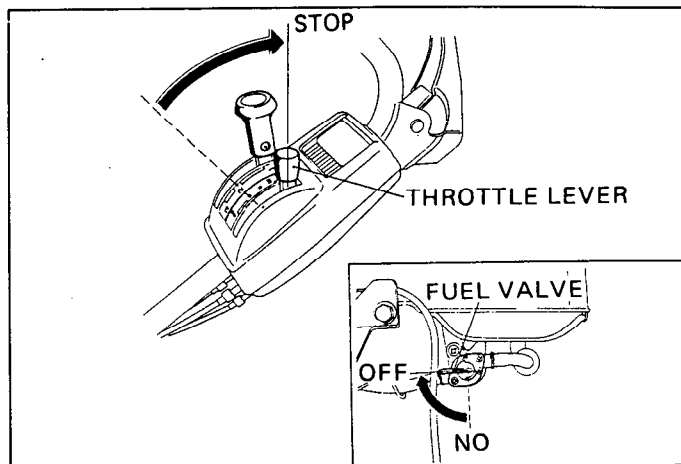

Cutting Height Adjustment

Five settings are available: 1", 1-1/2", 2", 2-1/2", 3".
To change blade height:

1. Stop the engine.
2. Push the adjusting lever toward the wheel and move it up or down to raise or lower the blade height.
3. Release the lever in the appropriate notch.
4. Adjust the other three wheels. Make sure all four wheels are at the same level.

WARNING

- * *Be careful not to touch the muffler when adjusting the right front wheel height.
The muffler will stay hot for a while after the engine is stopped.*

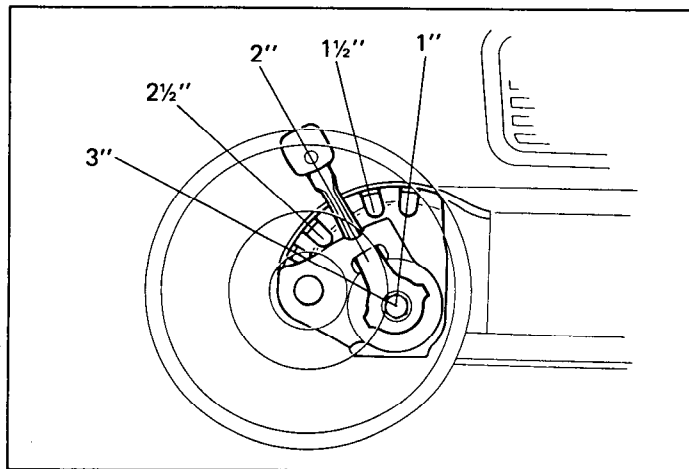
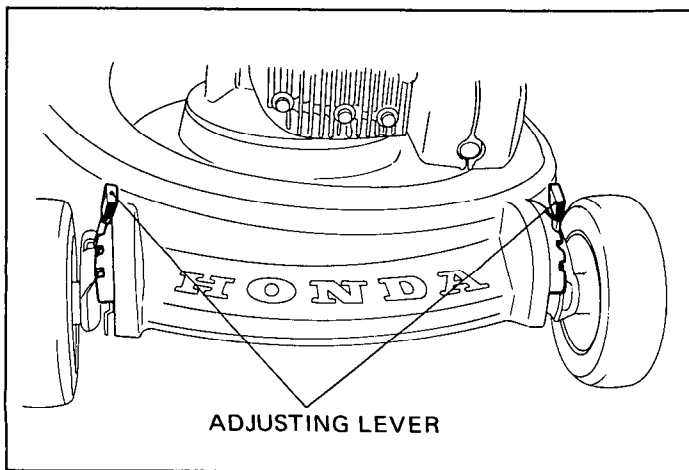
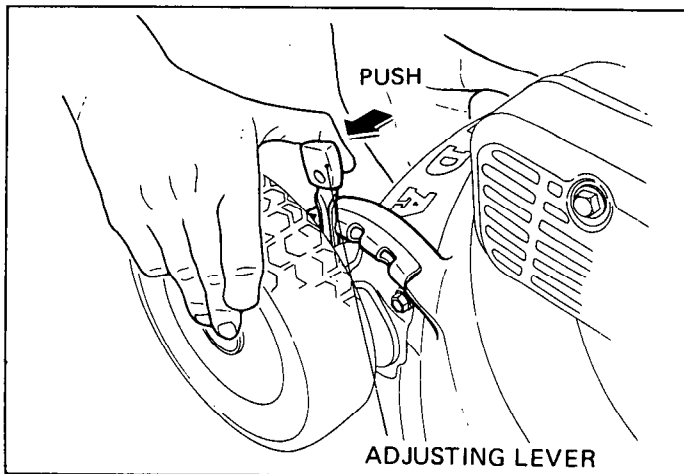

Grass Bag

The bag is subject to wear under normal usage; frequently check for fraying and tears. Replace deteriorated bags only with Honda replacement bags or equivalent. When the bag needs cleaning, wash it with water and make sure it is dry before using it. Clogged mesh will result in poor grass chuting and a wet bag will clog quickly.

Removal

1. Stop the engine. Unhook the grip from the handlebars.
2. Lift the lock lever, grasp the handle and remove the bag toward the rear of the mower.

Installation Notes

- * Reverse the removal procedure.
- * Be sure the lock lever is securely engaged or the discharge guard will not open completely and grass will not chute properly.

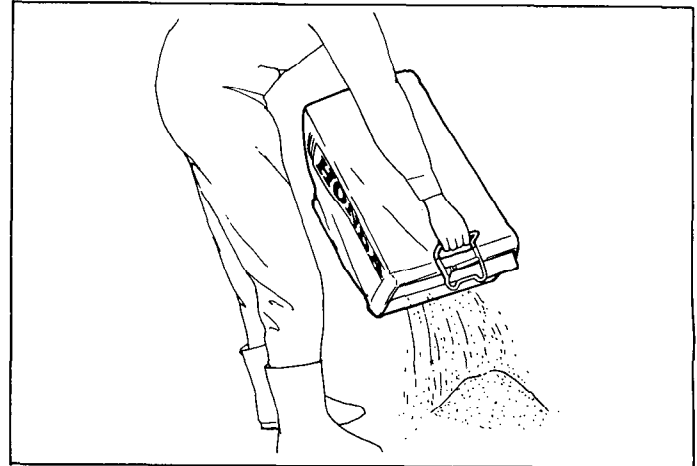
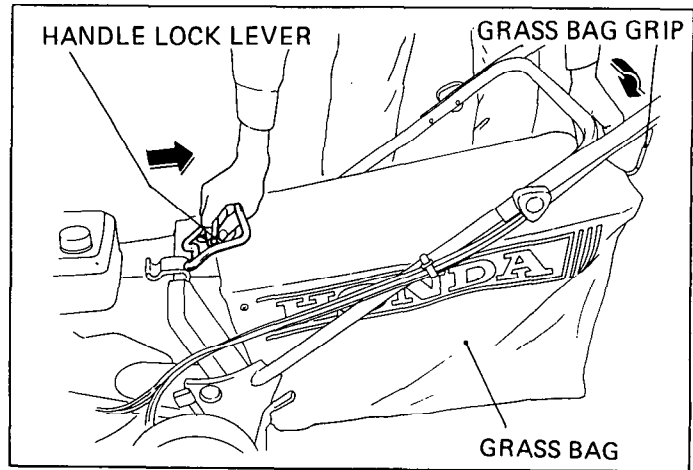

TRANSPORTING/STORAGE

Transporting

Turn the fuel valve OFF when transporting the mower.

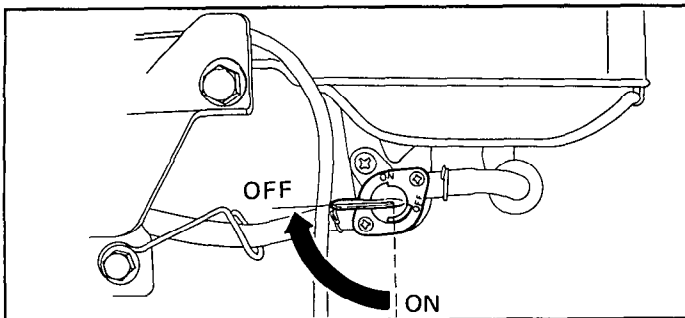

WARNING

* To avoid fuel and oil spillage do not tilt the unit; spilled fuel may ignite.

The handle may be folded for convenience:

1. Remove the grass bag (p. 17).
2. Push the handle lock levers down and move the handle forward until it stops.
3. Loosen the handle joints and collapse the handle as shown.

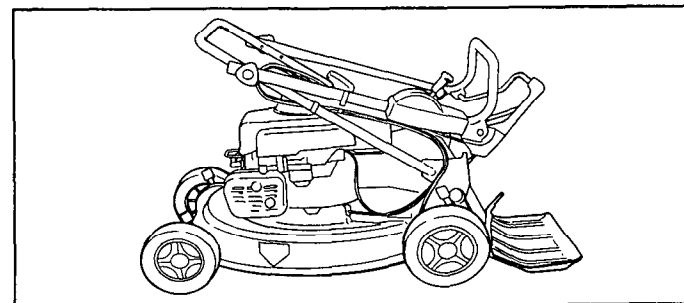
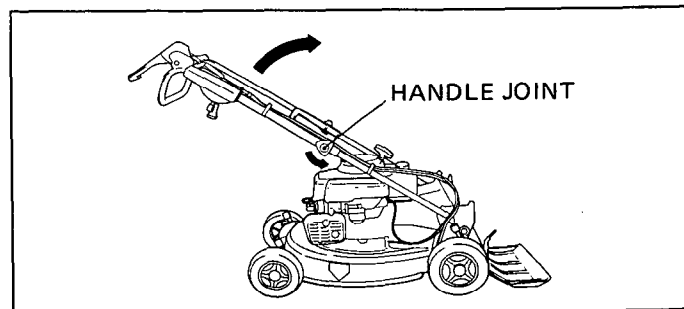
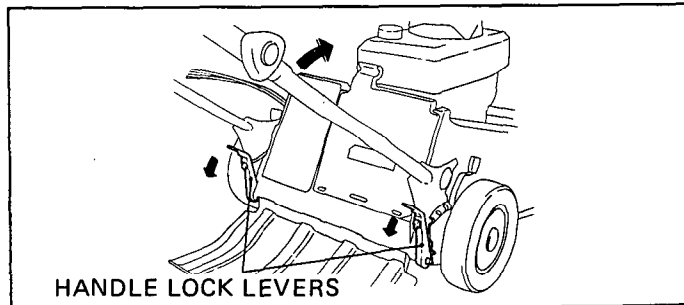

Preparation for Storage

The following steps should be taken to protect the mower whenever it will be stored for longer than 30 days.

NOTE:

If the mower will be stored for longer than a year, first remove the spark plug and pour three table-spoonsful of clean motor oil into the cylinder. Pull the starter rope slowly two or three times to distri-bute the oil.

Replace the plug.

1. Drain the fuel tank and carburetor into an ap-proved gasoline container:
 - A. Remove the fuel tube and turn the fuel valve ON to empty the fuel tank.
 - B. Loosen the carburetor drain bolt to drain the carburetor.
 - C. Retighten the drain bolt, connect the fuel tube and turn the fuel valve OFF.

WARNING

* *Gasoline is extremely flammable and explosive un-der certain conditions. Do not smoke or allow flames or sparks in the area.*

2. Change the engine oil (p. 23).

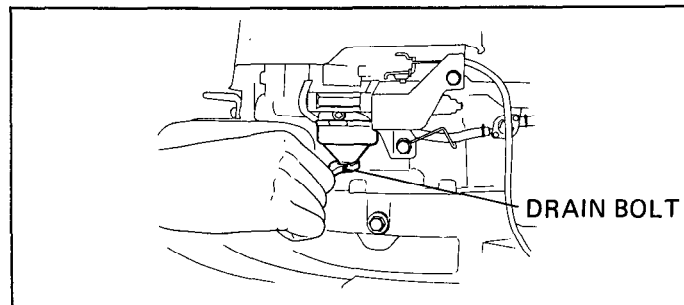
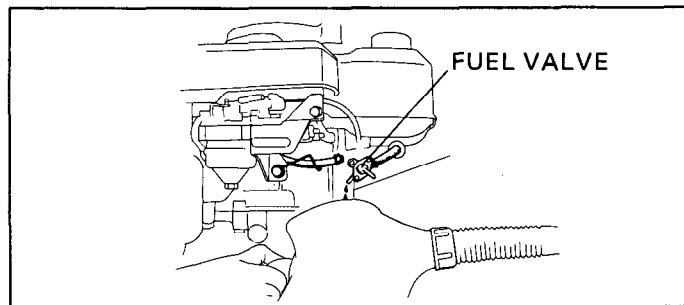
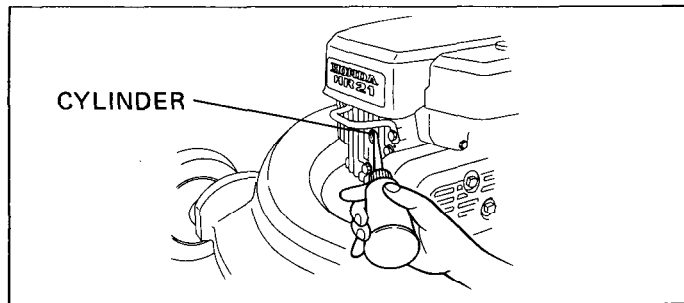

3. Pull the starter rope until it becomes hard to pull. This closes the valves and breaker points (non-CDI models), and protects them from dust and corrosion.
4. Coat areas that may rust with a light film of oil. Cover the mower and store it on a level surface in a dry, dust free area.

Removal From Storage

1. Remove the spark plug; check that it is clean and properly gapped (p. 25). Pull the starter rope several times.
2. Thread the spark plug in as far as possible by hand, then use the plug wrench to tighten $1/8$ to $1/4$ turn further.
3. Check the engine oil level and condition.
4. Fill the fuel tank and start the engine.

NOTE:

If the cylinder was coated with oil, the engine will smoke at start up; this is normal.

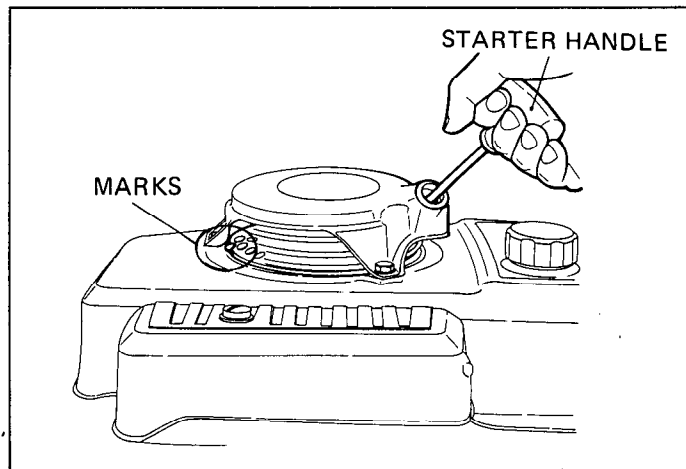

MAINTENANCE

WARNING

- * *To prevent accidental start-up, shut off the engine and disconnect the spark plug cap before performing any maintenance.*

CAUTION

- * *Use only genuine Honda parts or their equivalent for maintenance or repair. Replacement parts which are not of equivalent quality may damage the mower.*

Periodic inspection and adjustment of the Honda HR21 is essential if high level performance is to be maintained. Regular maintenance will also ensure a long service life. The required service intervals and the kind of maintenance to be performed are described in the following chart.

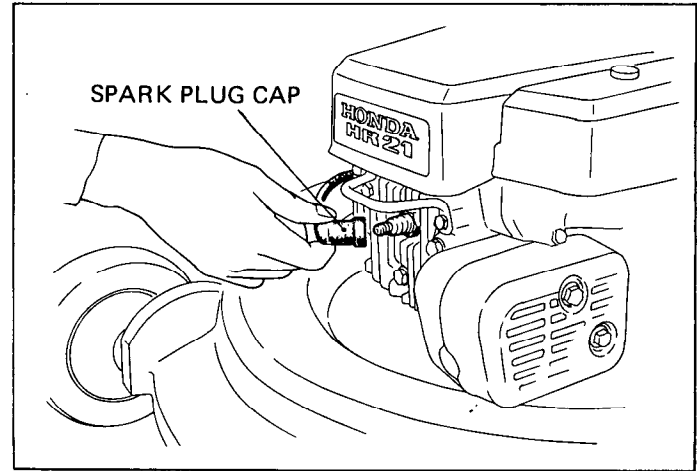

MAINTENANCE SCHEDULE

REGULAR SERVICE PERIOD		Each Use	First 1 month or 20 Hrs. (3)	Every 1 month or 20 Hrs. (3)	Every 6 months or 100 Hrs. (3)	Every one year or 300 Hrs. (3)
Item	Perform at every indicated month or operating hour interval, whichever comes first.					
Engine oil	Check level	○				
Engine oil	Change		○		○	
Air cleaner element	Check	○				
Air cleaner element	Clean			○ (1)		
Fuel strainer	Check				○	
Spark plug	Clean-Adjust				○	
Blade bolts (Tightness)	Check	○				
Gass bag	Check	○				
Throttle cable	Adjust					○
V-belt	Inspection					○
Drive clutch cable	Adjust					○
ROTO-STOP cable	Adjust				○	
ROTO-STOP	Check				○ (2)	
Ignition timing	Check-Adjust					○ (2)
Valve clearance	Check-Adjust					○ (2)
Combustion chamber	Clean-Lap valves					○ (2)
Fuel tank	Clean					○ (2)
Fuel tube	Check (Replace, if necessary)					○

(1) Service the air cleaner more frequently when used in dusty areas.

(2) These items should be serviced by an authorized Honda dealer, unless the owner has the proper tools and is mechanically proficient. See the Honda Shop Manual.

(3) For professional commercial use, log hours of operation to determine proper maintenance intervals.

ENGINE OIL CHANGE

Drain the oil while the engine is still warm to assure rapid and complete draining.

1. Remove the filler cap/dipstick using a screwdriver as illustrated.
2. Remove the drain bolt, drain the oil, and retighten the bolt securely.
3. Refill to the "Upper" level mark with the recommended oil (see p. 10). Tighten the cap securely to prevent leakage.

CAUTION

** Used motor oil may cause skin cancer if repeatedly left in contact with the skin for prolonged periods. Although this is unlikely unless you handle used oil on a daily basis, it is still advisable to thoroughly wash your hands with soap and water as soon as possible after handling used oil.*

NOTE:

Please dispose of used motor oil in a manner that is compatible with the environment. We suggest you take it in a sealed container to your local service station for reclamation. Do not throw it in the trash or pour it on the ground.

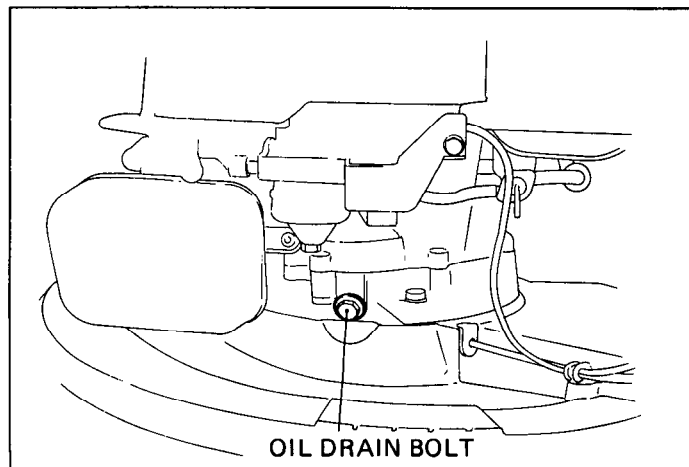
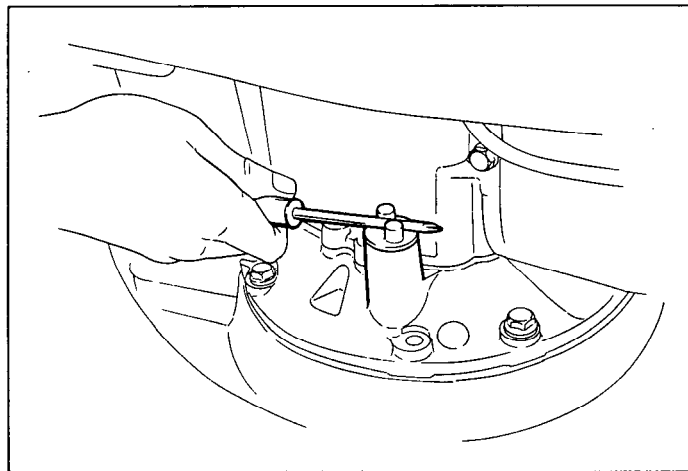

AIR CLEANER SERVICE

A dirty air cleaner will restrict air flow to the carburetor. To prevent carburetor malfunction, service the air cleaner frequently.

1. Remove the wing nuts and the air cleaner cover. Remove the elements and separate them. Carefully check both elements for holes or tears and replace if damaged.
2. Foam element: Clean in warm soapy water, rinse and allow to dry thoroughly. Or clean in high flash-point solvent and allow to dry. Dip the element in clean engine oil and squeeze out all the excess. The engine will smoke during initial start-up if too much oil is left in the foam.
3. Paper element: Tap the element lightly several times on a hard surface to remove excess dirt, or blow compressed air through the filter from the inside out. Never try to brush the dirt off; brushing will force dirt into the fibers. Clean in warm, soapy water and rinse. Dry using compressed air blown from the inside out, or shake the element and allow it to air dry thoroughly. (Or clean in high flash-point solvent, remove immediately, and allow to dry.) Oil the outside of the paper with a light aerosol oil such as WD-40. The engine will smoke during initial start-up if too much oil is used.

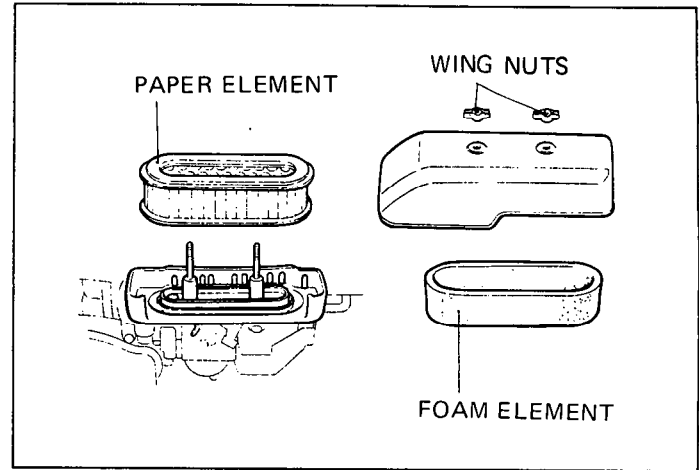

SPARK PLUG

Standard Plugs:

P-DAM: BMR-6A(NGK) or W20MR-U(ND)

S-XAM: BPM6A-10(NGK) or W20MP-U10(ND)

1. Disconnect the cap and remove the spark plug.
2. Visually inspect the plug. Discard the plug if it is heavily deposited or if the insulator is cracked or chipped.
3. Measure the plug gap with a wire-type feeler gauge; it should be 0.6 - 0.7 mm (0.024 - 0.028 in) for BM TYPE plugs, 0.9 - 1.0 mm (0.035 - 0.040 in) for BPM TYPE plugs. If adjustment is necessary, bend the side electrode carefully.
4. Make sure the sealing washer is in good condition, then thread the spark plug in by hand until it seats.
5. Use the wrench to tighten a new plug 1/2 turn further to compress the washer. If you are reusing the plug it should only take 1/8 - 1/4 turn after the plug seats.
6. Replace the spark plug cap.

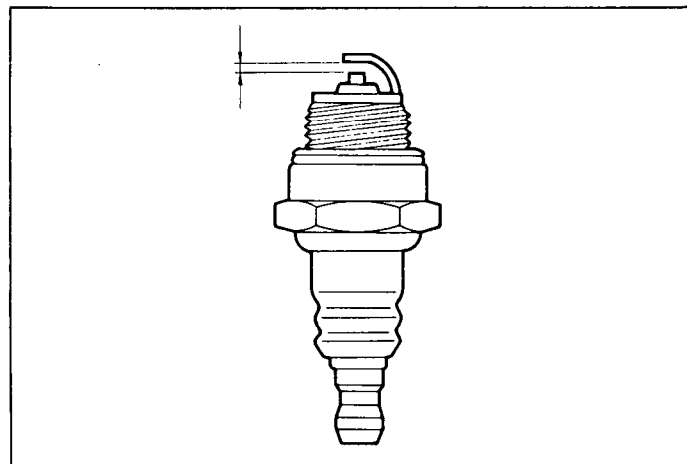
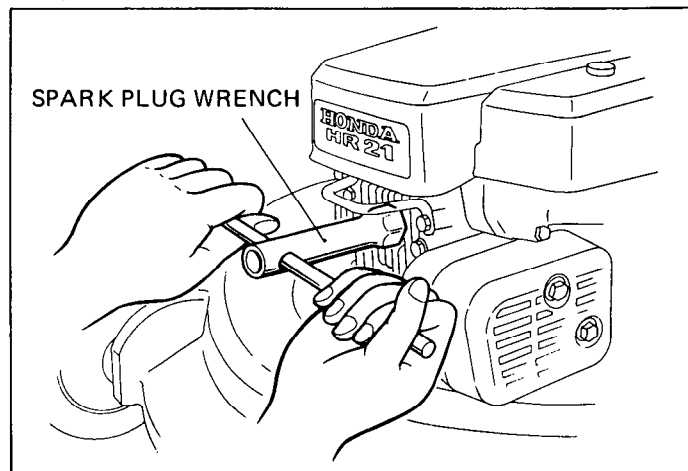

BLADE REMOVAL AND SHARPENING

WARNING

* *Wear heavy gloves to protect your hands.*

1. Tilt the mower so the carburetor side is up.
Loosen the blade bolts to remove the blade.
2. Sharpen the blade cutting edges with a file. File the top side only. Maintain the original bevel for a fine cutting edge. File both ends evenly to maintain blade balance.

NOTE:

Use only a genuine HONDA replacement blade or equivalent.

3. Clean away any dirt and grass from around the blade shaft.
4. Install the blade. Tighten the bolts securely.
Torque: 4.5 - 5.5 gk m (32.5 - 39.8 ft lb).

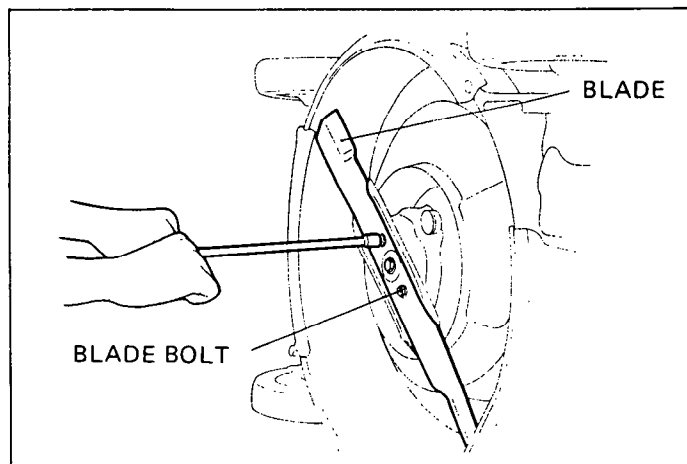
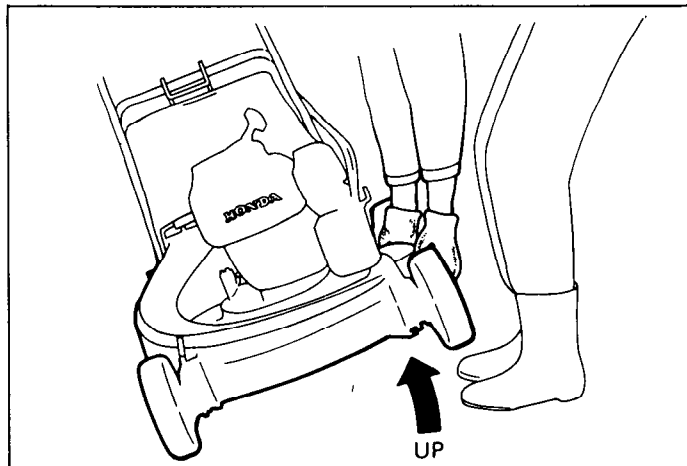

THROTTLE CONTROL CABLE ADJUSTMENT

1. Move the throttle lever to "CHOKE".
2. Push the control lever at the carburetor with your finger to check if it is positioned at the extreme right.
3. If adjustment is necessary, loosen the cable lock nut. Turn the adjusting bolt in or out as required until the lever is completely right. Tighten the lock nuts securely.
4. Start the engine and make sure the engine is stopped when moving the throttle control lever to "STOP".

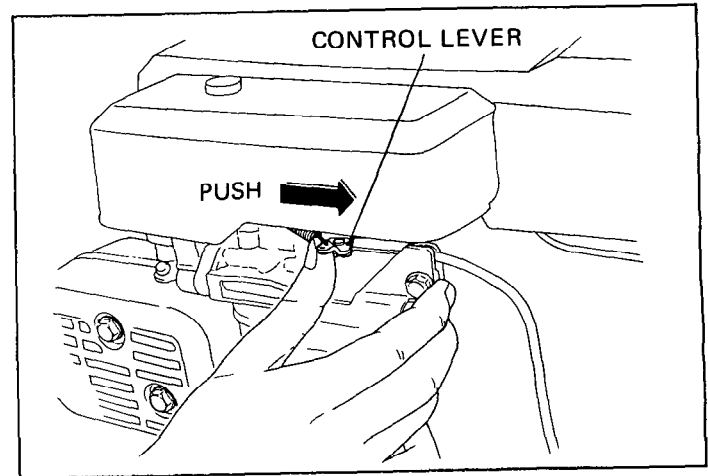
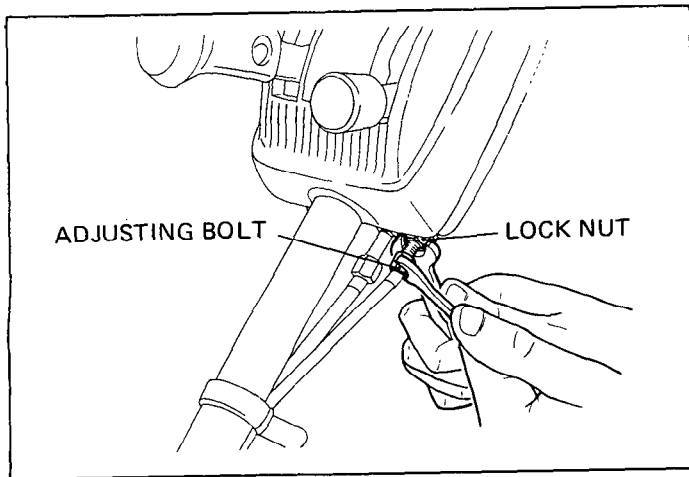
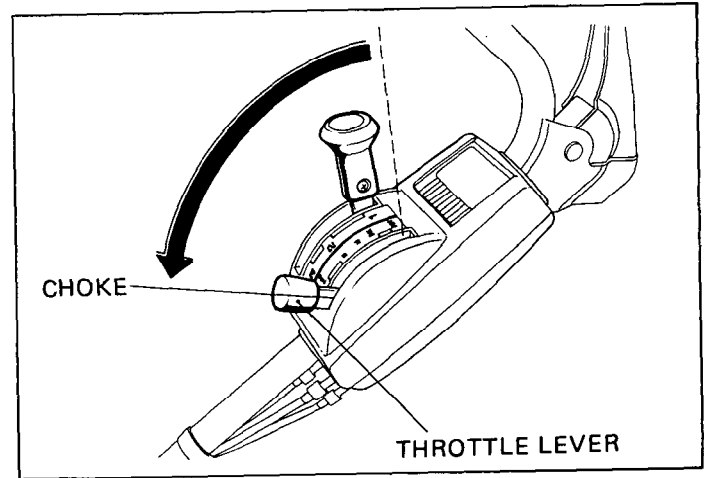

ROTO-STOP LEVER FREE PLAY

1. Measure free play at the tip of the lever as shown; it should be between 5 - 10 mm (3/16 - 3/8 in).
2. If adjustment is necessary, loosen the lock nut at the lever cable and turn the adjusting bolt to increase or decrease free play.
3. Tighten the lock nuts securely.
4. After adjusting, make sure the rotary blade is stopped when releasing the ROTO-STOP lever.

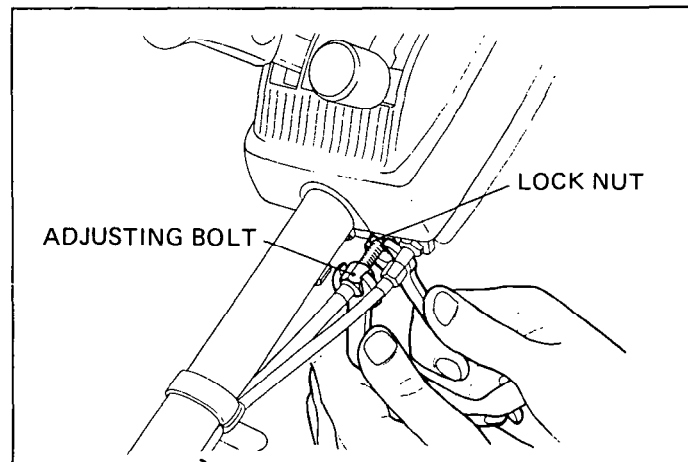
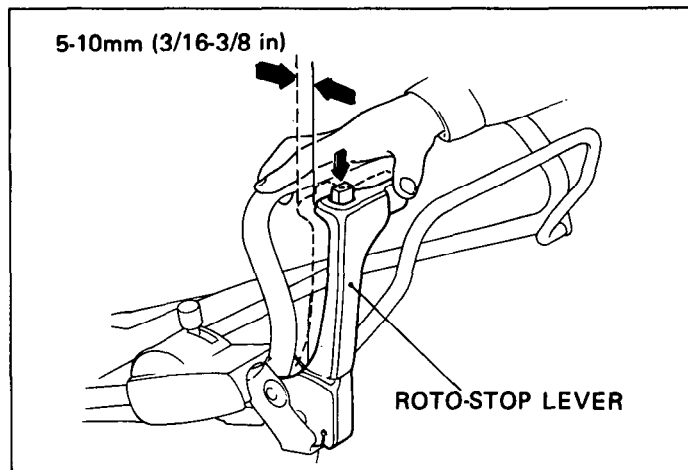

DRIVE CLUTCH FREE PLAY (S-XAM TYPE only)

1. Measure free play at the top of the lever as shown; it should be between 15-20 mm (19/32-25/32 in).
2. If adjustment is necessary, loosen the clutch cable lock nut and turn the adjusting bolt to increase or decrease free play.
3. Tighten the lock nuts securely.
4. After adjusting, make sure the drive clutch operates properly; moving forward when gripping and stopping to propell when releasing.

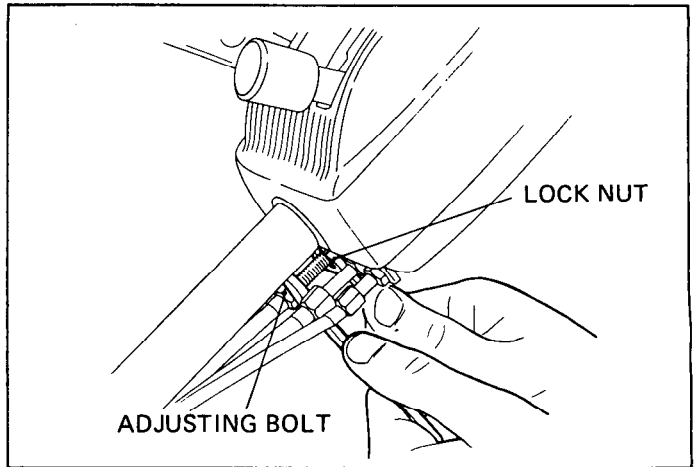
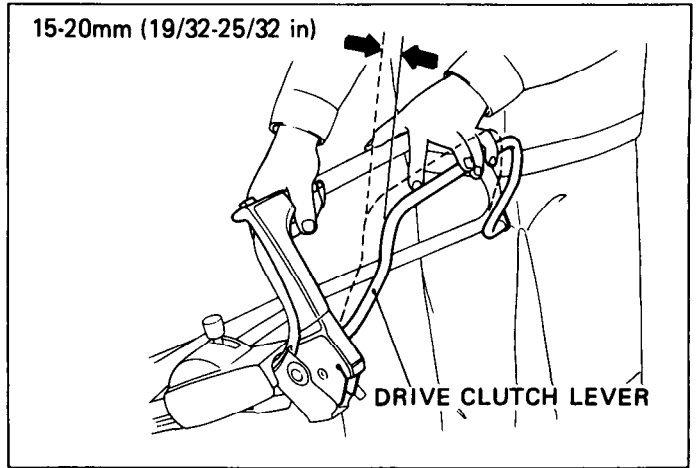

NOTE:

The following adjustments should be performed by an authorized Honda dealer unless the owner has the proper tools and is mechanically proficient.

1. Move the throttle lever to "IDLE" and start the engine.
2. Turn the throttle stop screw either in or out as required until the engine runs at 1,400 rpm.

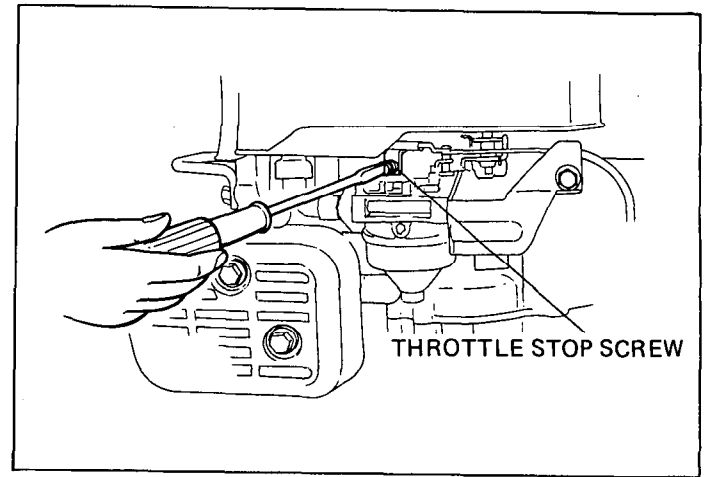

SHIFT CONTROL CABLE ADJUSTMENT (S-XAM TYPE only)

1. Move the shift lever to "3".
2. Remove the grass bag. Loosen the three 6 mm bolts and remove the bag opening panel.
3. Loosen the three 6 mm bolts and remove the belt cover.
4. Raise the movable driven face to move the drive belt to the smallest section of the pulley.
5. Loosen the cable lock nut and turn the adjusting bolt until there is no clearance between the contacting portions of the shift arm and tension arm.
6. Further turn the adjusting bolt 3 - 5 turns counter-clockwise from the point in step 5 above.
7. Tighten the lock nuts securely.

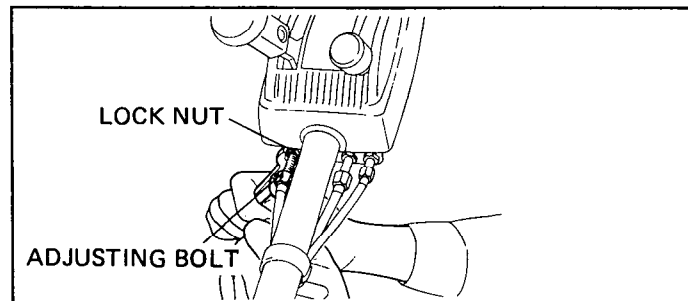
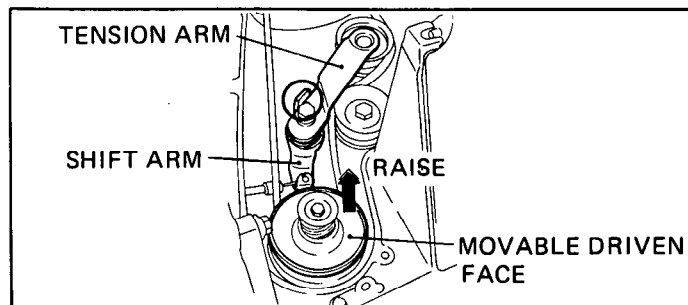
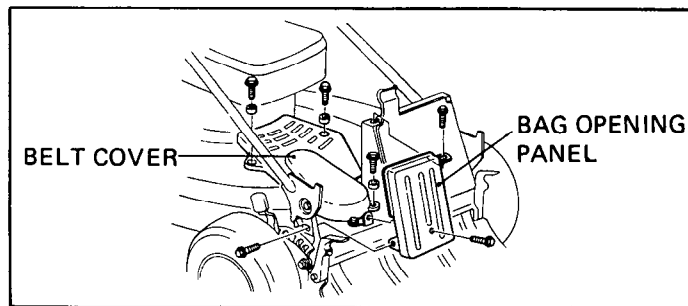

GRASS BAG ASSEMBLY

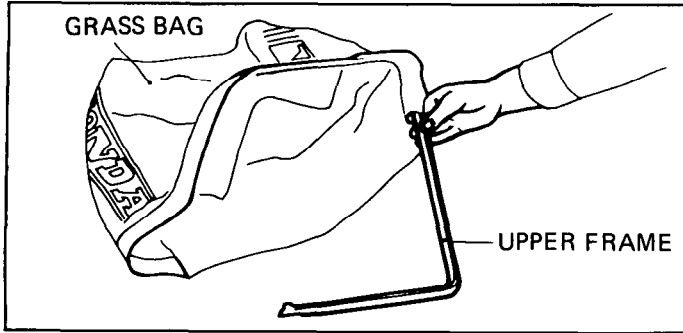

1. Work the upper frame into the grass bag. The side with two holes goes in first to match the holes in the side of the bag.

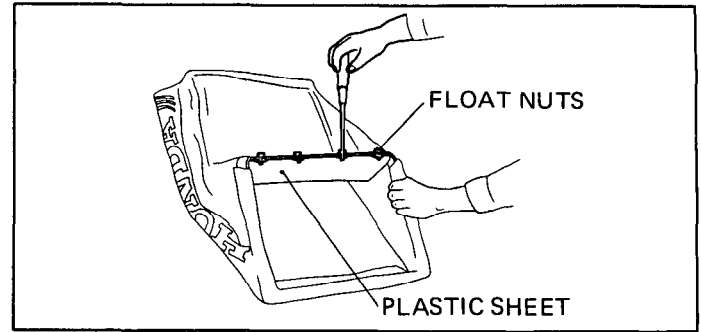

2. Install four float nuts onto the plastic sheet in the bottom of the bag. Point the lipped edge of the lower frame forward the rear and attach the lower frame to the upper frame by tightening two screws. Then attach the lower frame to the plastic sheet with four screws.

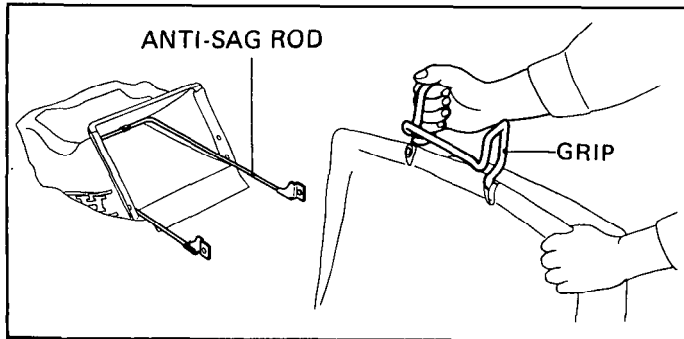

3. With the bag upside down, place the anti-sag rod in the bag and secure it to the upper frame with two screws and two washers. Install the bag grip on the rod through the slits in the bag end.

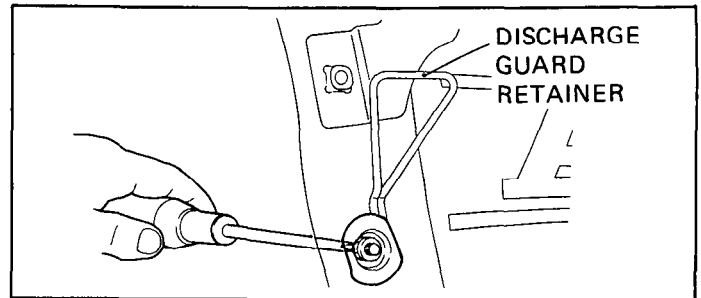

4. Install the discharge guard retainer as shown With a screw and a washer.

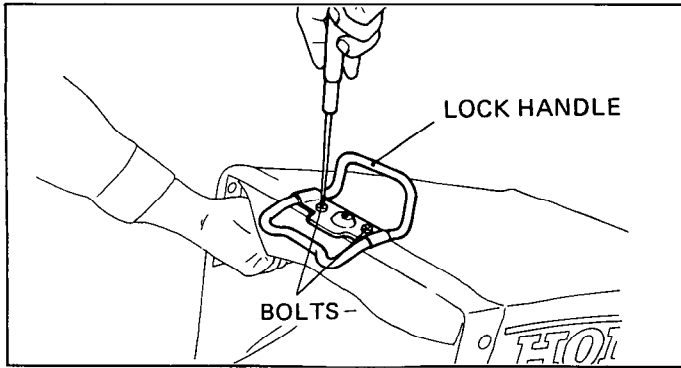

5. Install the lock handle to the bag with two screws.

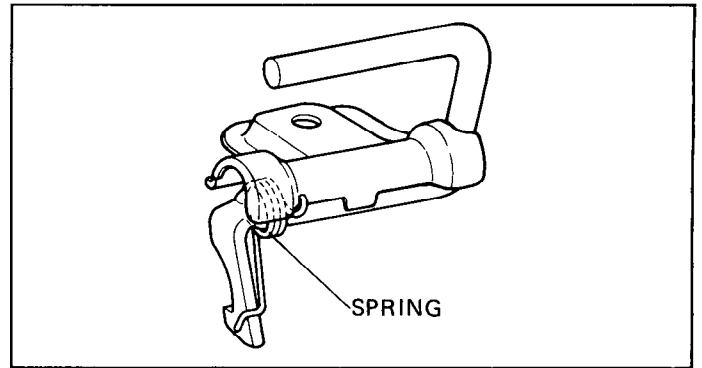

6. Install the spring on the lever with the long hook down. Slide the retaining bracket under the short hook and finger-tighten the bracket on the bag.

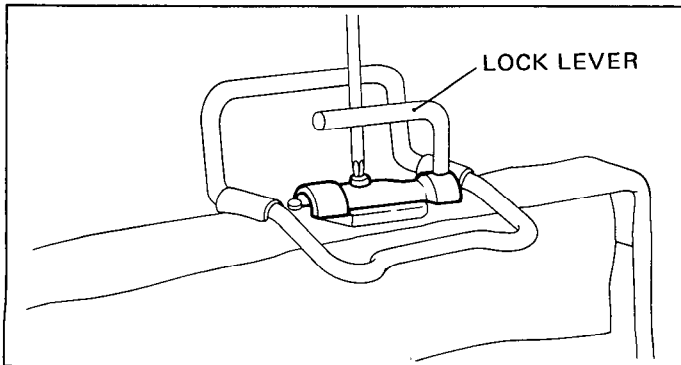

7. Hook the long end of the spring on the lever and tighten the bracket securely.

TROUBLESHOOTING CHART

Engine will not start

1. No fuel.
2. Throttle lever in “STOP” position.
3. Spark plug wire loose or disconnected.
4. Spark plug faulty or improperly gapped (p. 25).
5. Engine flooded (p. 15).
6. Dirty air cleaner.

Hard starting or loss of power

1. Dirt in gas tank.
2. Dirty air cleaner.
3. Water in gas tank.
4. Vent in gas cap and/or carburetor clogged.

Erratic operation

1. Spark plug faulty or improperly gapped (p.25).
2. Dirty air cleaner.

Engine overheats

1. Spark plug improperly gapped.
2. Dirty air cleaner.
3. Dirty cooling fins.
4. Low oil level.
5. Starter pulley clogged by grass, etc.

Excessive vibration

1. Loose blade or engine mounting hardware.
2. Blade unbalanced.

SPECIFICATIONS

MODEL	ROTARY MOWER HR21
ENGINE	GV150
Engine type	Side valve, single-cylinder, forced air-cooled four-stroke gasoline engine.
Displacement/Bore and stroke	144 cc (8.8 cu in)/64 x 45 mm (2.52 x 1.77 in)
Ignition timing	TYPE P-DAM: 20° BTDC, Fixed TYPE S-XAM CDI (Capacitor Discharge Ignition)
Ignition system	TYPE P-DAM: flywheel magneto ignition TYPE S-XAM: CDI
Engine oil capacity	0.6 l (1.3 US pt)
Fuel tank capacity	1.0 l (0.26 US gal)
Spark plug	TYPE P-DAM: BMR-6A (NGK), W20MR-U(ND) TYPE S-XAM: BPM6A-10 (NGK), W20MP-U10 (ND)

FRAME

Dimensions (Length x Width x Height)	1610x580x960 mm (63.4x22.8x37.8 in)
Dry weight	TYPE P-DAM: 42.0 kg (92.6 lb), S-XAM: 45.5 kg (100.3 lb)
Grass bag capacity	67 l (2.0 bu)
Cutting width	540 mm (21 in)

WARRANTY SERVICE

Owner Satisfaction

Your satisfaction and goodwill are important to your dealer and to us. All Honda warranty details are explained in the Distributor's Limited Warranty. Normally, any problems concerning the product will be handled by your dealer's service department. If you have a warranty problem that has not been handled to your satisfaction, we suggest you take the following action:

- Discuss your problem with a member of dealership management. Often complaints can be quickly resolved at that level. If the problem has already been reviewed with the Service Manager, contact the owner of the dealership or the General Manager.
- If your problem still has not been resolved to your satisfaction, contact the Power Equipment Customer Relations Department of American Honda Motor Co., Inc.

American Honda Motor Co., Inc.
Power Equipment Customer Relations Department
P.O. Box 50
Gardena, California 90247-0805
Telephone: (213) 604-2400

We will need the following information in order to assist you:

- Your name, address, and telephone number
- Product model and serial number
- Date of purchase
- Dealer name and address
- Nature of the problem

After reviewing all the facts involved, you will be advised of what action can be taken. Please bear in mind that your problem will likely be resolved at the dealership, using the dealer's facilities, equipment, and personnel, so it is very important that your initial contact be with the dealer.

Your purchase of a Honda product is greatly appreciated by both your dealer and American Honda Motor Co., Inc. We want to assist you in every way possible to assure your complete satisfaction with your purchase.



HONDA

HONDA MOTOR CO., LTD. TOKYO, JAPAN

31952040
00X31-952-0400

K2



5058709
PRINTED IN JAPAN