

HONDA

Power

Equipment

Owner's Manual

GENERATOR

EG5000X

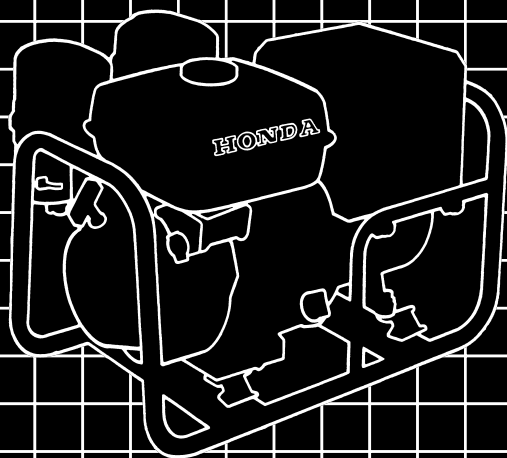



WARNING:



The engine exhaust from this product contains chemicals known to the State of California to cause cancer, birth defects or other reproductive harm.

▲WARNING

Exhaust contains poisonous carbon monoxide gas that can build up to dangerous levels in closed areas.

Breathing carbon monoxide can cause unconsciousness or death.

Never run the generator in a closed, or even partly closed area where people may be present.

▲WARNING

The generator is a potential source of electrical shock if misused. Do not expose the generator to moisture, rain or snow. Do not let the generator get wet, and do not operate it with wet hands.

Keep this owner's manual handy so that you can refer to it at any time. This owner's manual is considered a permanent part of the generator and should remain with the generator if resold.

The information and specifications included in this publication were in effect at the time of approval for printing. Honda Motor Co., Ltd. reserves the right, however, to discontinue or change specifications or design at any time without notice and without incurring any obligation whatever. No part of this publication may be reproduced without written permission.

INTRODUCTION

Congratulations on your selection of a Honda generator. We are certain you will be pleased with your purchase of one of the finest generators on the market.

We want to help you get the best results from your new generator and to operate it safely. This manual contains the information on how to do that; please read it carefully.

As you read this manual, you will find information preceded by a **NOTICE** symbol. That information is intended to help you avoid damage to your generator, other property, or the environment.

We suggest you read the warranty policy to fully understand its coverage and your responsibilities of ownership. The warranty policy is a separate document that should have been given to you by your dealer.

When your generator needs scheduled maintenance, keep in mind that your Honda servicing dealer is specially trained in servicing Honda generators. Your authorized Honda servicing dealer is dedicated to your satisfaction and will be pleased to answer your questions and concerns.

Best Wishes,
Honda Motor Co., Ltd.

A FEW WORDS ABOUT SAFETY

Your safety and the safety of others are very important. And using this generator safely is an important responsibility.

To help you make informed decisions about safety, we have provided operating procedures and other information on labels and in this manual. This information alerts you to potential hazards that could hurt you or others.

Of course, it is not practical or possible to warn you about all the hazards associated with operating or maintaining a generator. You must use your own good judgement.

You will find important safety information in a variety of forms, including:

- **Safety Labels** – on the generator.
- **Safety Messages** – preceded by a safety alert symbol  and one of three signal words, DANGER, WARNING, or CAUTION.

These signal words mean:

 **DANGER**

You **WILL** be **KILLED** or **SERIOUSLY HURT** if you don't follow instructions.

 **WARNING**

You **CAN** be **KILLED** or **SERIOUSLY HURT** if you don't follow instructions.

 **CAUTION**

You **CAN** be **HURT** if you don't follow instructions.

- **Safety Headings** – such as *IMPORTANT SAFETY INFORMATION*.
- **Safety Section** – such as *GENERATOR SAFETY*.
- **Instructions** – how to use this generator correctly and safely.

This entire book is filled with important safety information – please read it carefully.

CONTENTS

GENERATOR SAFETY	5
Safety Label Locations	5
Important Safety Information	6
COMPONENT IDENTIFICATION	8
CONTROLS	10
Engine Switch	10
Starter Grip	10
Fuel Valve Lever	11
Choke Lever	11
Circuit Breaker	12
Circuit Protector	12
Ground Terminal	13
Oil Alert System	13
Voltage Selector Switch (Dual Voltage System)	14
GENERATOR USE	15
Connections to a Building Electrical System	15
Ground System	15
Special Requirements	15
AC Applications	16
AC Operation	17
AC Receptacle Selection	18
High Altitude Operation	20
PRE-OPERATION CHECK	21
Engine Oil	21
Refueling	22
Fuel Recommendations	23
STARTING THE ENGINE	24
STOPPING THE ENGINE	25

MAINTENANCE	26
The Importance of Maintenance	26
Maintenance Safety	27
Maintenance Schedule	28
Engine Oil Change	29
Air Cleaner Service	30
Fuel Sediment Cup Cleaning	31
Spark Plug Service	32
Spark Arrester Maintenance	33
TRANSPORTING/STORAGE	34
Storage Procedure	35
TROUBLESHOOTING	36
TECHNICAL INFORMATION	38
Emission Control System Information	38
Air Index	41
Specifications	42
CONSUMER INFORMATION	43
Dealer Locator Information	43
Customer Service Information	43
Honda Publications	44
Wiring Diagram	45
INDEX	46

GENERATOR SAFETY

SAFETY LABEL LOCATIONS

These labels warn you of potential hazards that can cause serious injury. Read them carefully.

If a label comes off or becomes hard to read, contact your Honda generator dealer for a replacement.

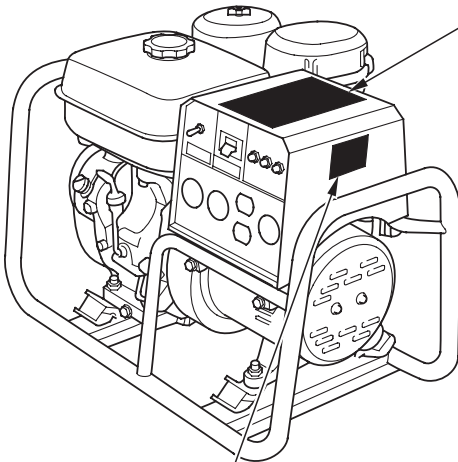

EG 5000X

A C

VOLTAGE 120/240V
FREQUENCY 60Hz
RATED OUTPUT 4.5kVA
MAX. OUTPUT 5.0kVA
PHASE 1 ϕ

FUEL GASOLINE (PETROL)

Honda Motor Co., Ltd. MADE IN JAPAN (A)

⚠ DANGER	
Using a generator indoors CAN KILL YOU IN MINUTES. Generator exhaust contains carbon monoxide. This is a poison you cannot see or smell.	
NEVER use inside a home or garage, EVEN IF doors and windows are open.	Only use OUTSIDE and far away from windows, doors, and vents.
⚠ WARNING	
	Gasoline is highly flammable and explosive. You could be burned or seriously injured if the gasoline is ignited. ■ Before refueling, stop the engine and keep heat, sparks, and flame away. ■ Handle fuel only outdoors. ■ Do not fill the fuel tank above the upper limit line. ■ Wipe up spills immediately.
	Exhaust contains poisonous carbon monoxide gas that can build up to dangerous levels in closed areas. Breathing carbon monoxide can cause unconsciousness or death. ■ Never run the generator in a closed, or even partly closed area where people may be present.
	Improper connections to a building can allow electrical current to backfeed into utility lines, creating an electrocution hazard. ■ Connections to a building must isolate generator power from utility power and comply with all applicable laws and electrical codes.
	The generator is a potential source of electrical shock if not kept dry. ■ Do not expose the generator to moisture, rain or snow. ■ Do not operate the generator with wet hands.
	Read owner's manual carefully before operation.

IMPORTANT SAFETY INFORMATION

Honda generators are designed to give safe and dependable service if operated according to instructions. Read and understand this owner's manual before operating your generator. You can help prevent accidents by being familiar with your generator's controls and by observing safe operating procedures.

Operator Responsibility

- Know how to stop the generator quickly in case of emergency.
- Understand the use of all generator controls, output receptacles, and connections.
- Be sure that anyone who operates the generator receives proper instruction. Do not let children operate the generator without parental supervision.

Carbon Monoxide Hazards

- Exhaust contains poisonous carbon monoxide, a colorless and odorless gas. Breathing carbon monoxide can cause loss of consciousness and may lead to death.
- If you run the generator in an area that is confined, or even partly enclosed area, the air you breathe could contain dangerous amount of exhaust gas.
- Never run your generator inside a garage, house, or near open windows or doors.

Electric Shock Hazards

- The generator produces enough electric power to cause a serious shock or electrocution if misused.
- Using a generator or electrical appliance in wet conditions, such as rain or snow, or near a pool or sprinkler system, or when your hands are wet, could result in electrocution. Keep the generator dry.
- If the generator is stored outdoors, unprotected from the weather, check all of the electrical components on the control panel before each use. Moisture or ice can cause a malfunction or short circuit in electrical components that could result in electrocution.
- Do not connect to a building's electrical system unless an isolation switch has been installed by a qualified electrician.

Fire and Burn Hazards

- The exhaust system gets hot enough to ignite some materials.
 - Keep the generator at least 3 feet (1 meter) away from buildings and other equipment during operation.
 - Do not enclose the generator in any structure.
 - Keep flammable materials away from the generator.
- The muffler becomes very hot during operation and remains hot for a while after stopping the engine. Be careful not to touch the muffler while it is hot. Let the engine cool before storing the generator indoors.
- Gasoline is extremely flammable and is explosive under certain conditions. Do not smoke or allow flames or sparks where the generator is refueled or where gasoline is stored. Refuel in a well-ventilated area with the engine stopped.
- Fuel vapors are extremely flammable and may ignite after the engine has started. Make sure that any spilled fuel has been wiped up before starting the generator.

COMPONENT IDENTIFICATION

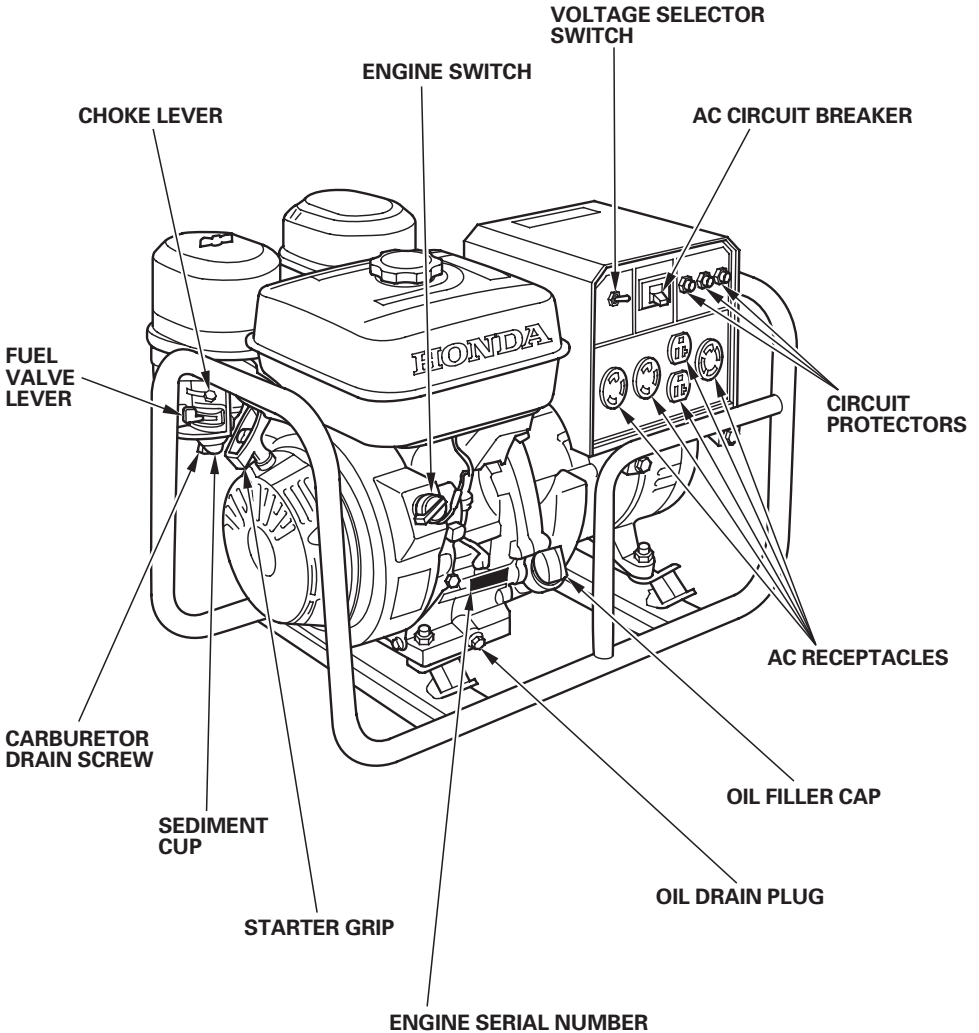

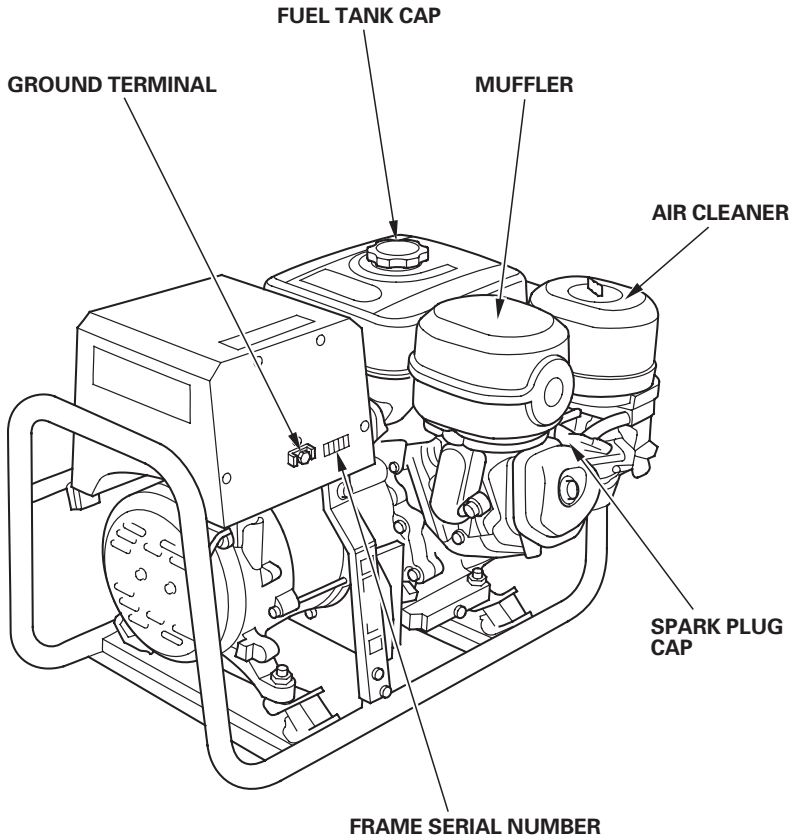

Record the engine and frame serial numbers and date of purchase for your future reference. Refer to these serial numbers when ordering parts and when making technical or warranty inquiries (see page 43).

Frame serial number: _____

Engine serial number: _____

Date of purchase: _____

CONTROLS

ENGINE SWITCH

To start and stop the engine.

Switch position:

OFF: To stop the engine.

ON: To start and run the engine.

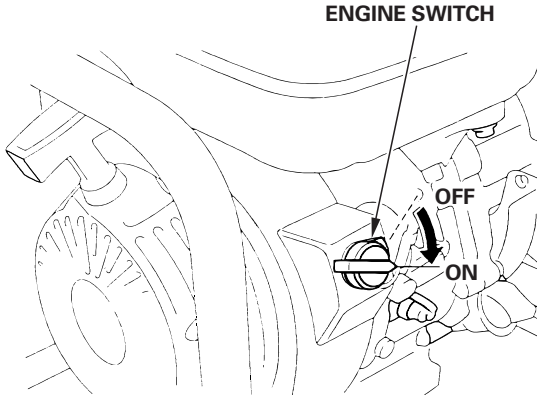

STARTER GRIP

To start the engine, pull the starter grip lightly until you feel resistance, then pull briskly in the direction of the arrow as shown below.

NOTICE

Do not allow the starter grip to snap back against the engine. Return it gently to prevent damage to the starter.

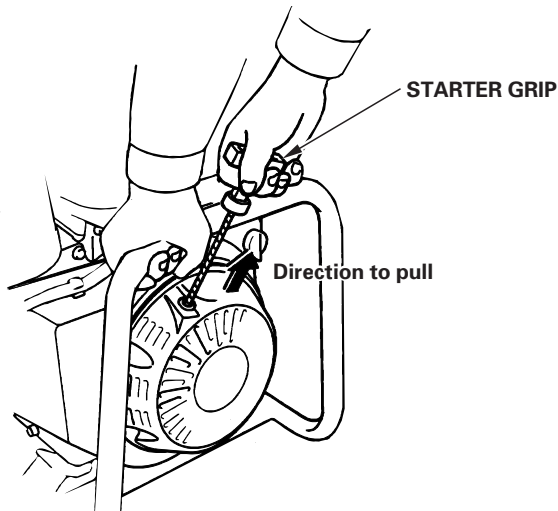

FUEL VALVE LEVER

The fuel valve is located on the carburetor. When the fuel valve lever is in the ON position, fuel is allowed to flow from the fuel tank to the carburetor. Be sure to return the fuel valve lever to the OFF position after stopping the engine.

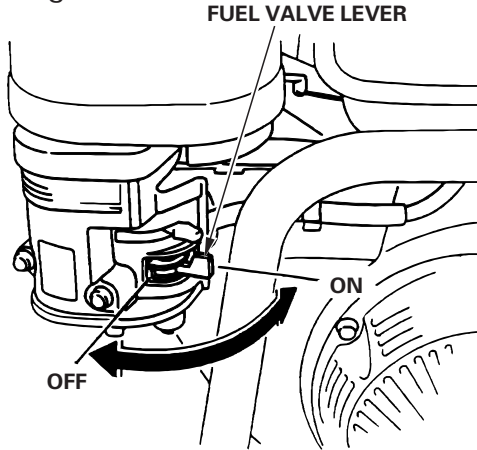

CHOKE LEVER

The choke is used to provide proper starting mixture when the engine is cold. It can be opened and closed by operating the choke lever manually. Move the choke lever to the CLOSED position to enrich the mixture for cold starting.

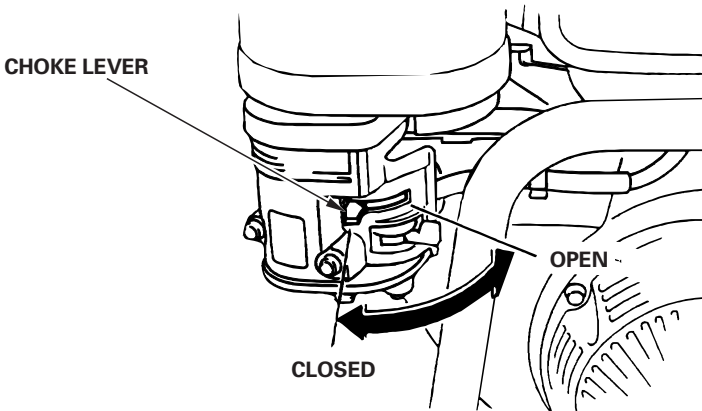

CIRCUIT BREAKER

The AC circuit breaker will automatically switch OFF if there is a short circuit or an overload of the generator at the AC receptacle. If the AC circuit breaker is switched OFF automatically, check that the appliance is working properly and does not exceed the rated load capacity of the AC circuit before switching the AC circuit breaker ON again.

The AC circuit breaker may be used to switch the generator AC power ON or OFF.

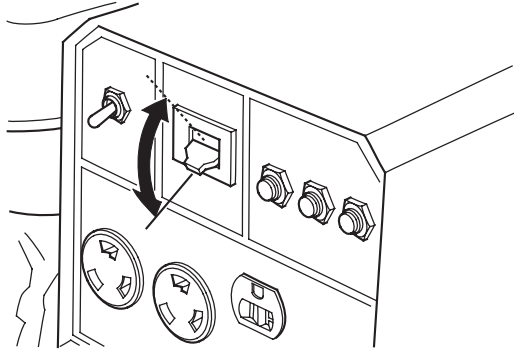

CIRCUIT PROTECTOR

The circuit protectors will automatically switch OFF if there is a short circuit or a significant overload of the generator at the 120V 20A, 120V 30A locking plug, or 120/240V 20A locking plug receptacle. If a circuit protector switches OFF automatically, check that the appliance is working properly and does not exceed the rated load capacity of the circuit before resetting the circuit protector to the ON position.

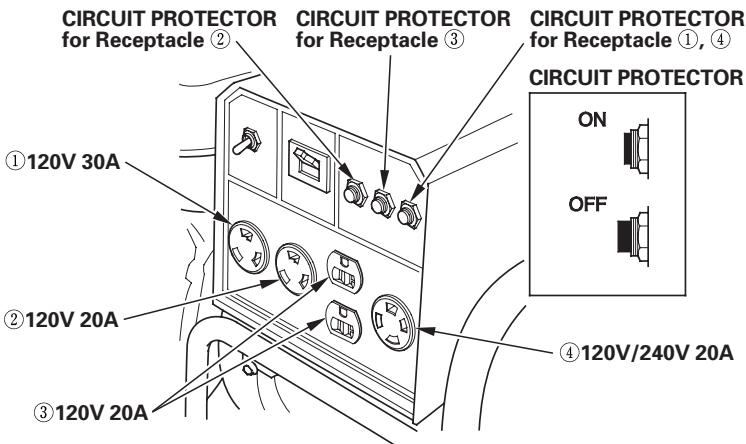

GROUND TERMINAL

The generator ground terminal is connected to the frame of the generator, the metal non-current-carrying parts of the generator, and the ground terminals of each receptacle.

Before using the ground terminal, consult a qualified electrician, electrical inspector, or local agency having jurisdiction for local codes or ordinances that apply to the intended use of the generator.

GROUND TERMINAL

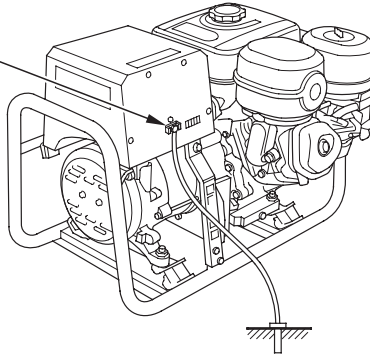

OIL ALERT® SYSTEM

The Oil Alert system is designed to prevent engine damage caused by an insufficient amount of oil in the crankcase. Before the oil level in the crankcase can fall below a safe limit, the Oil Alert system will automatically stop the engine (the engine switch will remain in the ON position).

If the engine stops and will not restart, check the engine oil level (see page 21) before troubleshooting in other areas.

OIL DRAIN PLUG

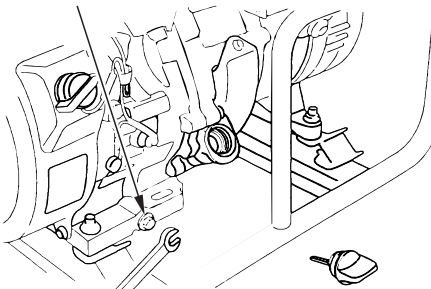

UPPER LEVEL

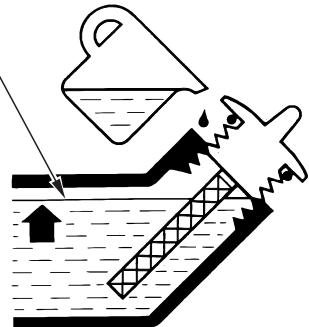

VOLTAGE SELECTOR SWITCH (DUAL VOLTAGE SYSTEM)

The voltage selector switches the main power carrying windings of the generator to produce "120V ONLY" or "120/240V". If a 240V appliance is connected to the 4-prong receptacle, the switch must be in the "120/240V" position. If only a 120V appliance is being connected to any of the 120V 3-prong receptacles, select the "120V ONLY" position.

120/240V: The 120V and 120/240V receptacles can be used simultaneously.

120V ONLY: ONLY the 120V receptacles can be used. Do not use the 120/240V receptacle in this position. Rated power will be available at the 30A 120V locking plug receptacle.

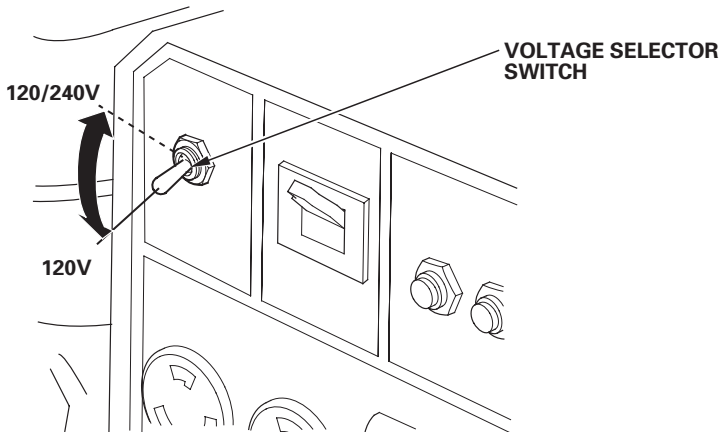

CONNECTIONS TO A BUILDING ELECTRICAL SYSTEM

Connections for standby power to a building electrical system must be made by a qualified electrician. The connection must isolate the generator power from utility power, and must comply with all applicable laws and electrical codes. A transfer switch, which isolates generator power from utility power, is available through authorized Honda generator dealers (see page 43).

▲WARNING

Improper connections to a building electrical system can allow electrical current from the generator to backfeed into the utility lines. Such backfeed may electrocute utility company workers or others who contact the lines during a power outage, and the generator may explode, burn, or cause fires when utility power is restored. Consult the utility company or a qualified electrician.

GROUND SYSTEM

Honda portable generators have a system ground that connects generator frame components to the ground terminals in the AC output receptacles. The system ground is not connected to the AC neutral wire. If the generator is tested by a receptacle tester, it will not show the same ground circuit condition as for a home receptacle.

SPECIAL REQUIREMENTS

There may be Federal or State Occupational Safety and Health Administration (OSHA) regulations, local codes, or ordinances that apply to the intended use of the generator. Please consult a qualified electrician, electrical inspector, or the local agency having jurisdiction.

- In some areas, generators are required to be registered with local utility companies.
- If the generator is used at a construction site, there may be additional regulations that must be observed.

AC APPLICATIONS

Before connecting an appliance or power cord to the generator:

- Make sure that it is in good working order. Faulty appliances or power cords can create a potential for electrical shock.
- If an appliance begins to operate abnormally, becomes sluggish, or stops suddenly, turn it off immediately. Disconnect the appliance, and determine whether the problem is the appliance or the rated load capacity of the generator has been exceeded.
- Make sure that the electrical rating of the tool or appliance does not exceed that of the generator. Never exceed the maximum power rating of the generator. Power levels between rated and maximum may be used for no more than 30 minutes.

NOTICE

Substantial overloading will open the circuit breaker. Exceeding the time limit for maximum power operation or slightly overloading the generator may not switch the circuit breaker OFF, but will shorten the service life of the generator.

Limit operation requiring maximum power to 30 minutes.

Maximum power is:

5.0 kVA

For continuous operation, do not exceed the rated power.

Rated power is:

4.5 kVA

The total power requirements (VA) of all appliances connected must be considered. Appliance and power tool manufacturers usually list rating information near the model number or serial number.

AC OPERATION

1. Start the engine (see page 24).
2. Turn the voltage selector switch to either position.

With the voltage selector switch in the "120/240V" position, you can use the 120V and 120/240V receptacles simultaneously. If you are NOT using the 120/240V receptacle but require more power from the 120V locking plug receptacle, then select the "120V ONLY" position.

3. Switch ON the AC circuit breaker.
4. Plug in the appliance.

Most motorized appliances require more than their rated wattage for startup.

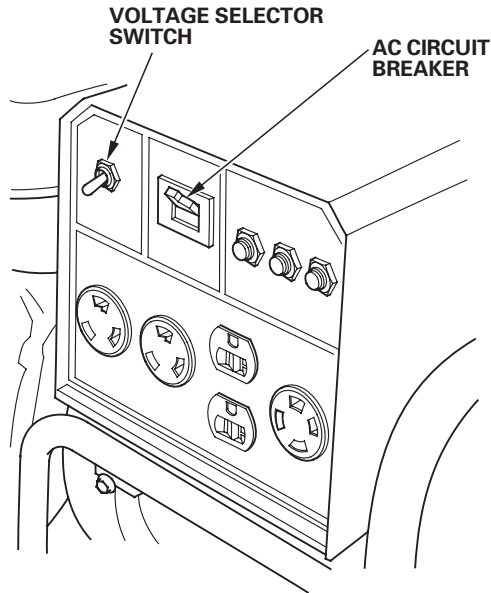

Do not exceed the current limit specified for any one receptacle. If an overloaded circuit causes the AC circuit breaker to switch OFF, reduce the electrical load on the circuit, wait a few minutes and then reset the AC circuit breaker.

AC RECEPTACLE SELECTION

The control panel, shown below, has a voltage selector switch and five receptacles. Receptacle #4 and #5 comprise one 240-volt receptacle with two powered terminals.

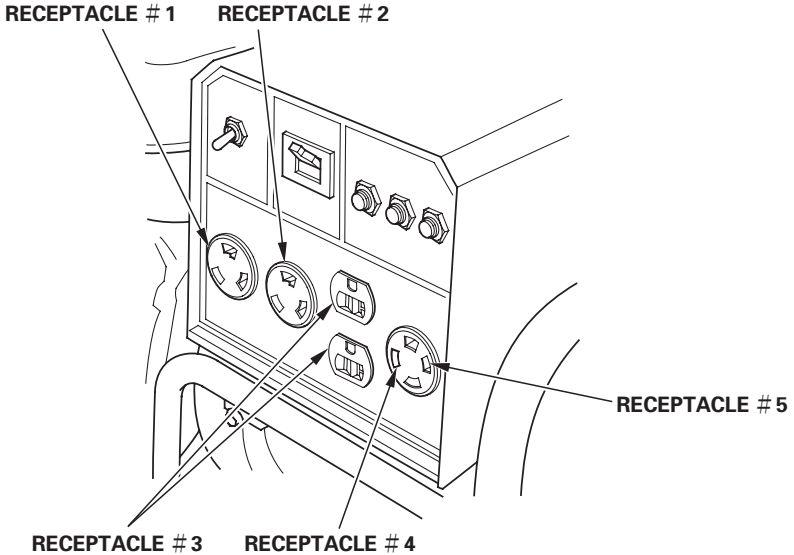

Power Producing Circuits

This generator is equipped with two power generating circuits. When the voltage selector switch is in the 120V/240V position, each of the two power producing circuits supplies power to specific receptacles. When the voltage selector switch is in the 120V ONLY position, the power producing circuits operate in parallel, sharing the total load connected to receptacles 1, 2, 3, and 4.

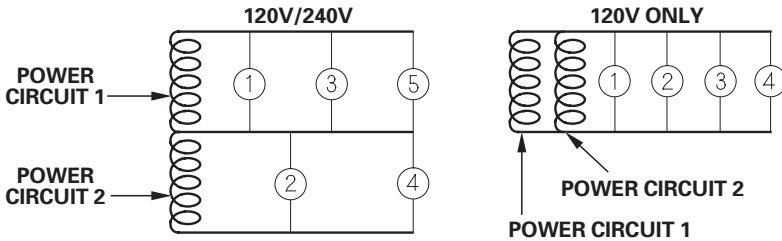

Voltage Selector Switch

The power available to each receptacle depends on the position of the voltage selector switch.

Switch Position	Receptacle	Available Power
120V ONLY	1	30A at 120V
	2	20A at 120V
	3	20A at 120V
	4	20A at 120V
	5	None
120V/240V	1	18.8A at 120V
	2	18.8A at 120V
	3	18.8A at 120V
	4-5	18.8A at 240V

120V ONLY Position

When the voltage selector switch is in the 120V ONLY position, you do not need to spread the load over the receptacles. You must, however, make sure the load on any receptacle does not exceed its available power shown in the preceding table and the total load does not exceed 37.5 amps.

120V/240V Position

When the voltage selector switch is in the 120V/240V position, you must balance the load. Divide the load between the two sets of receptacles shown below. Balancing is necessary because each set of receptacles is powered by only one power producing circuit that can produce a maximum of 18.8 amps.

Set of Receptacles	Total Current Available	Power Producing Circuit
1+3+5	18.8A	1
2+4	18.8A	2

HIGH ALTITUDE OPERATION

At high altitude, the standard carburetor air/fuel mixture will be too rich. Performance will decrease, and fuel consumption will increase. A very rich mixture will also foul the spark plug and cause hard starting. Operation at an altitude that differs from that at which this engine was certified, for extended periods of time, may increase emissions.

High altitude performance can be improved by specific modifications to the carburetor. If you always operate your generator at altitudes above 5,000 feet (1,500 meters), have your servicing dealer perform this carburetor modification. This engine, when operated at high altitude with the carburetor modifications for high altitude use, will meet each emission standard throughout its useful life.

Even with carburetor modification, engine horsepower will decrease about 3.5% for each 1,000-foot (300-meter) increase in altitude. The effect of altitude on horsepower will be greater than this if no carburetor modification is made.

NOTICE

When the carburetor has been modified for high altitude operation, the air/fuel mixture will be too lean for low altitude use. Operation at altitudes below 5,000 feet (1,500 meters) with a modified carburetor may cause the engine to overheat and result in serious engine damage. For use at low altitudes, have your servicing dealer return the carburetor to original factory specifications.

PRE-OPERATION CHECK

Before beginning your pre-operation checks, be sure the generator is on a level surface and the engine switch is in the OFF position.

ENGINE OIL

NOTICE

Engine oil is a major factor affecting engine performance and service life. Non-detergent and 2-stroke engine oils will damage the engine and are not recommended.

Check the oil level EACH USE with the generator on a level surface and the engine stopped.

Use 4-stroke motor oil that meets or exceeds the requirements for API service classification SJ or later (or equivalent). Always check the API SERVICE label on the oil container to be sure it includes the letter SJ or later (or equivalent).

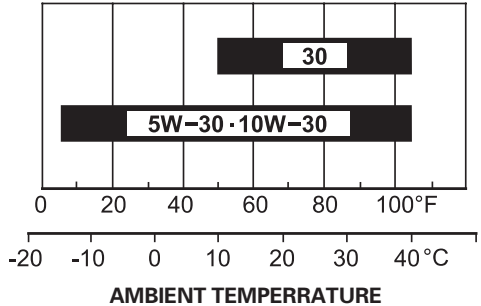

SAE 10W-30 is recommended for general, all-temperature use. Other viscosities shown in the chart may be used when the average temperature in your area is within the indicated range.

1. Remove the oil filler cap and wipe the dipstick clean.
2. Check the oil level by inserting the dipstick into the filler neck without screwing it in.
3. If the level is low, fill to the upper limit of the oil filler neck with the recommended oil.

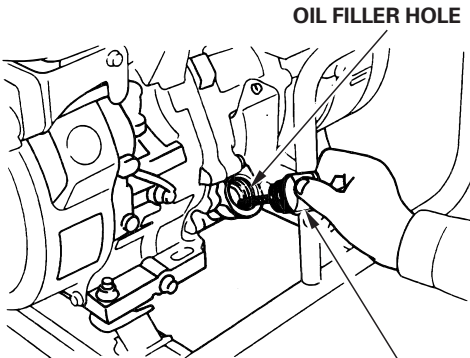

OIL FILLER CAP/DIPSTICK

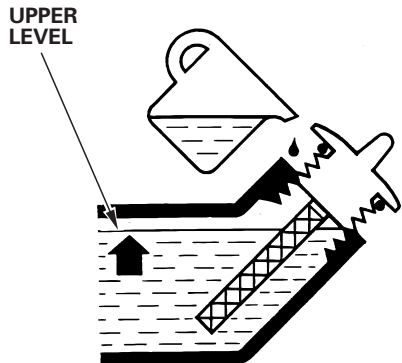

REFUELING

With the engine stopped, remove the fuel tank cap and check the fuel level. Refill the fuel tank if the fuel level is low.

▲WARNING

Gasoline is highly flammable and explosive.

You can be burned or seriously injured when handling fuel.

- **Stop the engine and keep heat, sparks, and flame away.**
- **Handle fuel only outdoors.**
- **Wipe up spills immediately.**

Refuel in a well-ventilated area with the engine stopped. If the engine has been running, allow it to cool first. Refuel carefully to avoid spilling fuel. Do not fill above the upper limit mark.

Never refuel the engine inside a building where gasoline fumes may reach flames or sparks. Keep gasoline away from appliance pilot lights, barbecues, electric appliances, power tools, etc.

Spilled fuel is not only a fire hazard, it causes environmental damage. Wipe up spills immediately.

NOTICE

Fuel can damage paint and plastic. Be careful not to spill fuel when filling your fuel tank. Damage caused by spilled fuel is not covered under warranty.

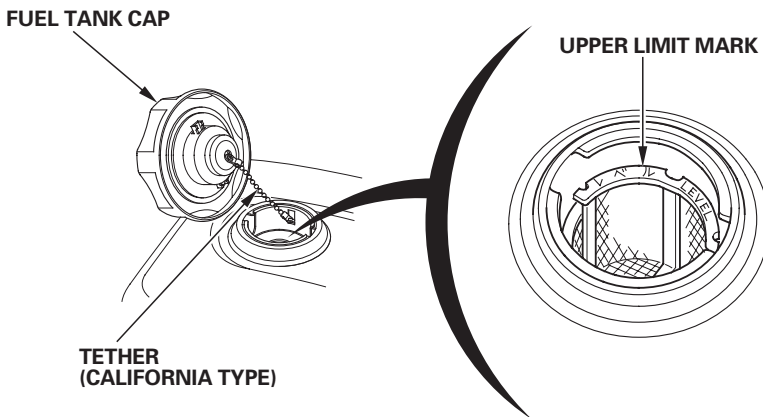

After refueling, reinstall the fuel tank cap securely.

FUEL RECOMMENDATIONS

This engine is certified to operate on regular unleaded gasoline with a pump octane rating of 86 or higher.

Never use stale or contaminated gasoline or an oil/gasoline mixture. Avoid getting dirt or water in the fuel tank.

You may use regular unleaded gasoline containing no more than 10% ethanol (E10) or 5% methanol by volume. In addition, methanol must contain cosolvents and corrosion inhibitors.

Use of fuels with content of ethanol or methanol greater than shown above may cause starting and/or performance problems. It may also damage metal, rubber, and plastic parts of the fuel system.

Engine damage or performance problems that result from using a fuel with percentages of ethanol or methanol greater than shown above are not covered under warranty.

STARTING THE ENGINE

STARTING THE ENGINE

For your safety, do not operate the generator in an enclosed area such as a garage. Your generator's exhaust contains poisonous carbon monoxide gas that can collect rapidly in an enclosed area and cause illness or death.

▲WARNING

Exhaust contains poisonous carbon monoxide gas that can build up to dangerous levels in closed areas.

Breathing carbon monoxide can cause unconsciousness or death.

Never run the generator in a closed, or even partly closed area where people may be present.

To prevent a possible fire, keep the generator at least 3 feet (1 meter) away from building walls and other equipment during operation. Do not place flammable objects close to the engine.

NOTICE

Operating this generator less than 3 feet (1 meter) from a building or other obstruction can cause overheating and damage the generator. For proper cooling, allow at least 3 feet (1 meter) of empty space above and around the generator.

Refer to *AC APPLICATIONS* (see page 16) for connecting loads to the generator.

1. Perform the *PRE-OPERATION CHECK* (see page 21).
2. Make sure that the AC circuit breaker is in the OFF position. The generator may be hard to start if a load is connected.
3. Turn the fuel valve lever to the ON position.
4. Turn the choke lever to the CLOSED position.
5. Turn the engine switch to the ON position.
6. Pull the starter grip lightly until resistance is felt, then pull briskly.

NOTICE

Do not allow the starter grip to snap back against the engine. Return it gently to prevent damage to the starter or housing.

7. As the engine warms up, slowly turn the choke lever to the OPEN position.

STOPPING THE ENGINE

STOPPING THE ENGINE

In an emergency:

1. To stop the engine in an emergency, turn the engine switch to the OFF position.

In normal use:

1. Turn the AC circuit breaker to the OFF position.
2. Turn the engine switch to the OFF position.
3. Turn the fuel valve lever to the OFF position.

MAINTENANCE

THE IMPORTANCE OF MAINTENANCE

Good maintenance is essential for safe, economical, and trouble-free operation. It will also help reduce air pollution.

▲WARNING

Improper maintenance, or failure to correct a problem before operation, can cause a malfunction in which you can be seriously hurt or killed.

Always follow the inspection and maintenance recommendations and schedules in this owner's manual.

To help you properly care for your generator, the following pages include a maintenance schedule, routine inspection procedures, and simple maintenance procedures using basic hand tools. Other service tasks that are more difficult or require special tools are best handled by professionals and are normally performed by a Honda technician or other qualified mechanic.

The maintenance schedule applies to normal operating conditions. If you operate your generator under severe conditions, such as sustained high-load or high-temperature operation, or use it in unusually wet or dusty conditions, consult your servicing dealer for recommendations applicable to your individual needs and use.

Remember that your servicing dealer knows your generator best and is fully equipped to maintain and repair it.

To ensure the best quality and reliability, use only new, Honda Genuine parts or their equivalents for repair or replacement.

Maintenance, replacement, or repair of the emission control devices and systems may be performed by any engine repair establishment or individual, using parts that are "certified" to EPA standards.

MAINTENANCE SAFETY

Some of the most important safety precautions follow. However, we cannot warn you of every conceivable hazard that can arise in performing maintenance. Only you can decide whether or not you should perform a given task.

▲WARNING

Failure to properly follow maintenance instructions and precautions can cause you to be seriously hurt or killed.

Always follow the procedures and precautions in the owner's manual.

Safety Precautions

- Make sure the engine is off before you begin any maintenance or repairs. This will eliminate several potential hazards:
 - **Carbon monoxide poisoning from engine exhaust.**
Operate outside away from open windows or doors.
 - **Burns from hot parts.**
Let the engine and exhaust system cool before touching.
 - **Injury from moving parts.**
Do not run the engine unless instructed to do so.
- Read the instructions before you begin, and make sure you have the tools and skills required.
- To reduce the possibility of fire or explosion, be careful when working around gasoline. Use only a non-flammable solvent, not gasoline, to clean parts. Keep cigarettes, sparks, and flames away from all fuel-related parts.

MAINTENANCE SCHEDULE

REGULAR SERVICE PERIOD (3)		Each use	First month or 20 Hrs.	Every 3 months or 50 Hrs.	Every 6 months or 100 Hrs.	Every year or 300 Hrs.
ITEM	Perform at every indicated month or operating hour interval, whichever comes first.					
Engine oil	Check level	○				
	Change		○		○	
Air cleaner	Check	○				
	Clean			○(1)		
Sediment Cup	Clean				○	
Spark plug	Check-adjust				○	
	Replace					○
Spark arrester	Clean				○	
Valve clearance	Check-adjust					○(2)
Combustion chamber	Clean	After every 500 Hrs.(2)				
Fuel tank and filter	Clean				○(2)	
Fuel tube	Check	Every 2 years (Replace if necessary) (2)				

NOTE:

- (1) Service more frequently when used in dusty areas.
- (2) These items should be serviced by your Honda servicing dealer, unless you have the proper tools and are mechanically proficient. Refer to the Honda shop manual for service procedures.
- (3) For commercial use, log hours of operation to determine proper maintenance intervals.

Failure to follow this maintenance schedule could result in non-warrantable failures.

ENGINE OIL CHANGE

Drain the oil while the engine is warm to assure rapid and complete draining.

1. Remove the drain plug and sealing washer, remove the oil filler cap, and drain the oil.
2. Reinstall the drain plug and sealing washer. Tighten the plug securely.
3. Refill with the recommended oil (see page 21) and check the oil level.

OIL DRAIN PLUG

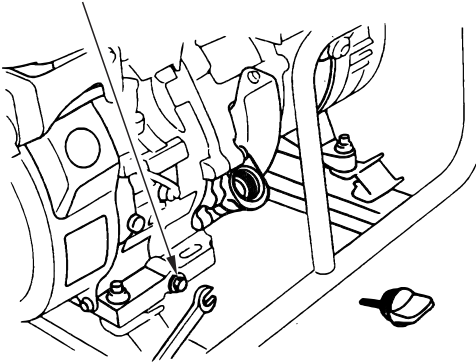

UPPER LEVEL

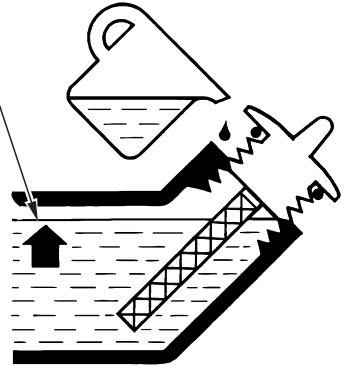

Wash your hands with soap and water after handling used oil.

Please dispose of used motor oil in a manner that is compatible with the environment. We suggest you take it in a sealed container to your local service station or recycling center for reclamation. Do not throw it in the trash, pour it on the ground, or pour it down a drain.

AIR CLEANER SERVICE

A dirty air cleaner will restrict air flow to the carburetor. To prevent carburetor malfunction, service the air cleaner regularly. Service more frequently when operating the generator in extremely dusty areas.

▲WARNING

Using gasoline or flammable solvent to clean the air filter can cause a fire or explosion. Use only soapy water or non-flammable solvent.

NOTICE

Operating the engine without an air filter or with a damaged air filter will allow dirt to enter the engine, causing rapid engine wear. This type of damage is not covered by the Distributor's Limited Warranty.

1. Remove the wing nut and the air cleaner cover. Remove the elements and separate them. Carefully check both elements for holes or tears and replace if damaged.
2. Foam element: Wash the element in a solution of household detergent and warm water, then rinse thoroughly, or wash in non-flammable or high flash point solvent. Allow the element to dry thoroughly.
Soak the element in clean engine oil and squeeze out the excess oil. The engine will smoke during initial start-up if too much oil is left in the foam.
3. Paper element: Tap the element lightly several times on a hard surface to remove excess dirt, or blow compressed air through the filter from the inside out. Never try to brush the dirt off; brushing will force dirt into the fibers.
Replace the paper element if it is excessively dirty.

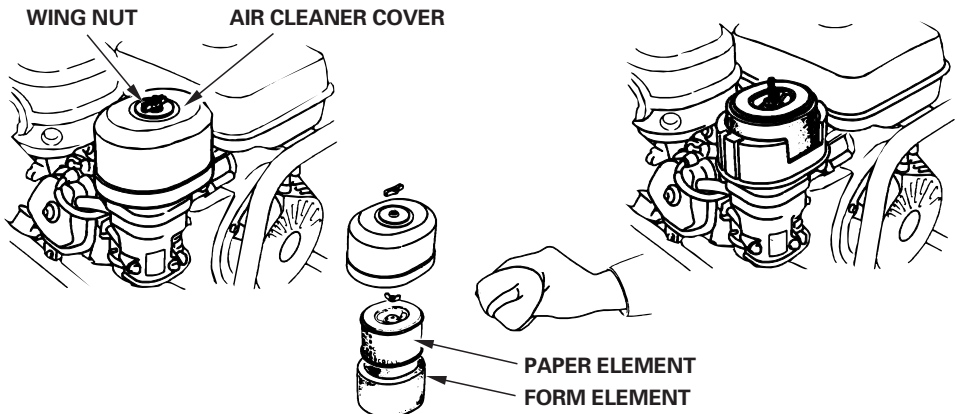

FUEL SEDIMENT CUP CLEANING

The sediment cup prevents dirt or water that may be in the fuel tank from entering the carburetor. If the engine has not been run for a long time, the sediment cup should be cleaned.

1. Turn the fuel valve lever to the OFF position. Remove the sediment cup, O-ring, and filter.
2. Clean the sediment cup, O-ring, and filter in non-flammable or high flash point solvent.
3. Reinstall the filter, O-ring, and sediment cup.
4. Turn the fuel valve lever ON and check for leaks.

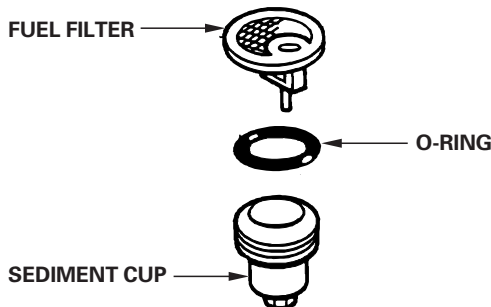
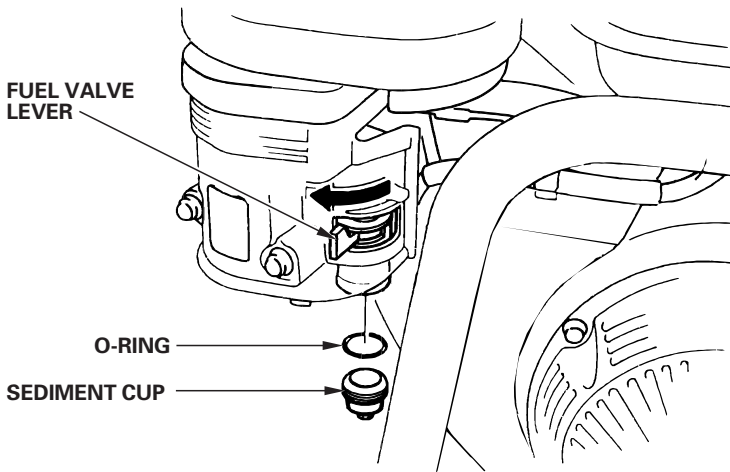

SPARK PLUG SERVICE

Recommended spark plugs: BPR5ES (NGK)
W16EPR-U (DENSO)

To ensure proper engine operation, the spark plug must be properly gapped and free of deposits.

If the engine has been running, the muffler will be very hot. Be careful not to touch the muffler.

1. Remove the spark plug cap.
2. Clean any dirt from around the spark plug base.
3. Use a spark plug wrench to remove the spark plug.

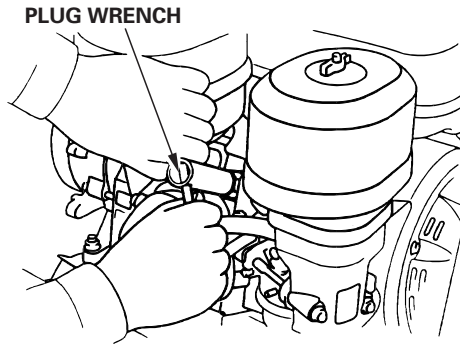

4. Visually inspect the spark plug. Discard it if the insulator is cracked or chipped. Clean the spark plug with a wire brush if it is to be reused.
5. Measure the plug gap with a wire-type feeler gauge. Correct as necessary by carefully bending the side electrode.

The gap should be:

0.028–0.031 in (0.7–0.8 mm)

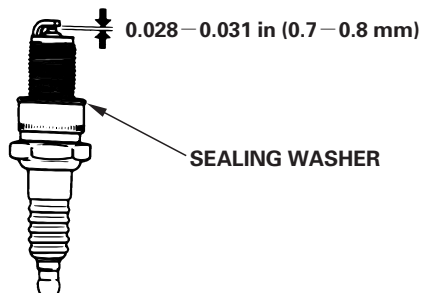

6. Check that the spark plug washer is in good condition, and thread the spark plug in by hand to prevent cross-threading.
7. After the spark plug is seated, tighten with a spark plug wrench to compress the washer.

—If installing a new spark plug, tighten 1/2 turn after the spark plug seats to compress the washer. If reinstalling a used spark plug, tighten 1/8–1/4 turn after the spark plug seats to compress the washer.

NOTICE

The spark plug must be securely tightened. An improperly tightened spark plug can become very hot and could damage the engine. Never use spark plugs which have an improper heat range. Use only the recommended spark plugs or equivalent.

SPARK ARRESTER MAINTENANCE

If the generator has been running, the muffler will be very hot. Allow it to cool before proceeding.

NOTICE

The spark arrester must be serviced every 100 hours to maintain its efficiency.

1. Remove the eight 5 mm screws ① from the muffler protector ② , and remove the muffler protector.
2. Remove the 4 mm screw ③ from the spark arrester ④ , and remove the spark arrester from the muffler ⑤.
3. Use a brush to remove carbon deposits from the spark arrester screen.
4. Inspect the spark arrester for breaks or holes, and replace it if necessary.
5. Install the spark arrester and the muffler in the reverse order of disassembly.

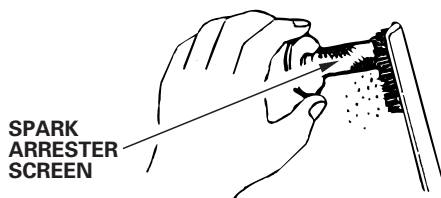
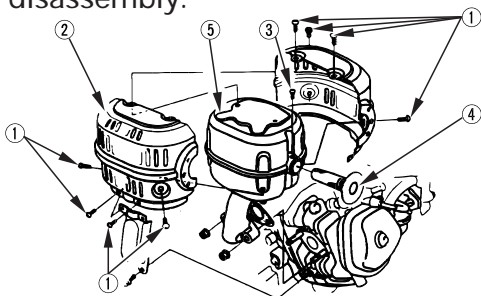

TRANSPORTING/STORAGE

When transporting the generator, turn the engine switch and the fuel valve OFF. Keep the generator level to prevent fuel spillage. Fuel vapor or spilled fuel may ignite.

▲WARNING

Contact with a hot engine or exhaust system can cause serious burns or fires. Let the engine cool before transporting or storing the generator.

Take care not to drop or strike the generator when transporting. Do not place heavy objects on the generator.

Before storing the unit for an extended period:

1. Be sure the storage area is free of excessive humidity and dust.
2. Service according to the table below:

STORAGE TIME	RECOMMENDED SERVICE PROCEDURE TO PREVENT HARD STARTING
Less than 1 month	No preparation required
1 to 2 months	Fill with fresh gasoline and add gasoline stabilizer *.
2 months to 1 year	Fill with fresh gasoline and add gasoline stabilizer *. Drain the carburetor float bowl. (page 35). Drain the fuel sediment cup. (page 31).
1 year or more	Fill with fresh gasoline and add gasoline stabilizer *. Drain the carburetor float bowl. (page 35). Drain the fuel sediment cup. (page 31). Remove the spark plug. Put a tablespoon of engine oil into the cylinder. Turn the engine slowly with the pull rope to distribute the oil. Reinstall the spark plug. Change the engine oil. (page 29). After removal from storage, drain the stored gasoline into a suitable container, and fill with fresh gasoline before starting.
*Use gasoline stabilizers that are formulated to extend storage life. Contact your authorized Honda generator dealer for stabilizer recommendations.	

Storage Procedure

1. Drain the carburetor by loosening the drain screw. Drain the gasoline into a suitable container.

▲WARNING

Gasoline is extremely flammable and is explosive under certain conditions. Perform this task in a well-ventilated area with the engine stopped. Do not smoke or allow flames or sparks in the area during this procedure.

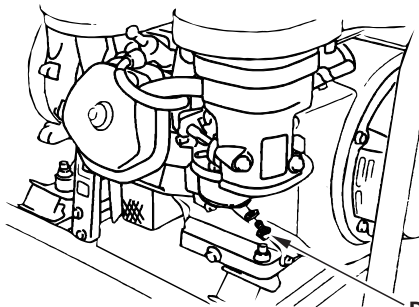

DRAIN SCREW

2. Change the engine oil (see page 29).
3. Remove the spark plug, and pour about a tablespoon of clean engine oil into the cylinder. Crank the engine several revolutions to distribute the oil, then reinstall the spark plug.
4. Slowly pull the starter grip until resistance is felt. At this point, the piston is coming up on its compression stroke and both the intake and exhaust valves are closed. Storing the engine in this position will help to protect it from internal corrosion.

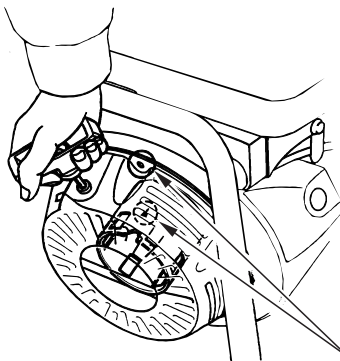

Align the notch on the starter pulley with the hole at the top of recoil starter.

TROUBLESHOOTING

When the engine will not start:

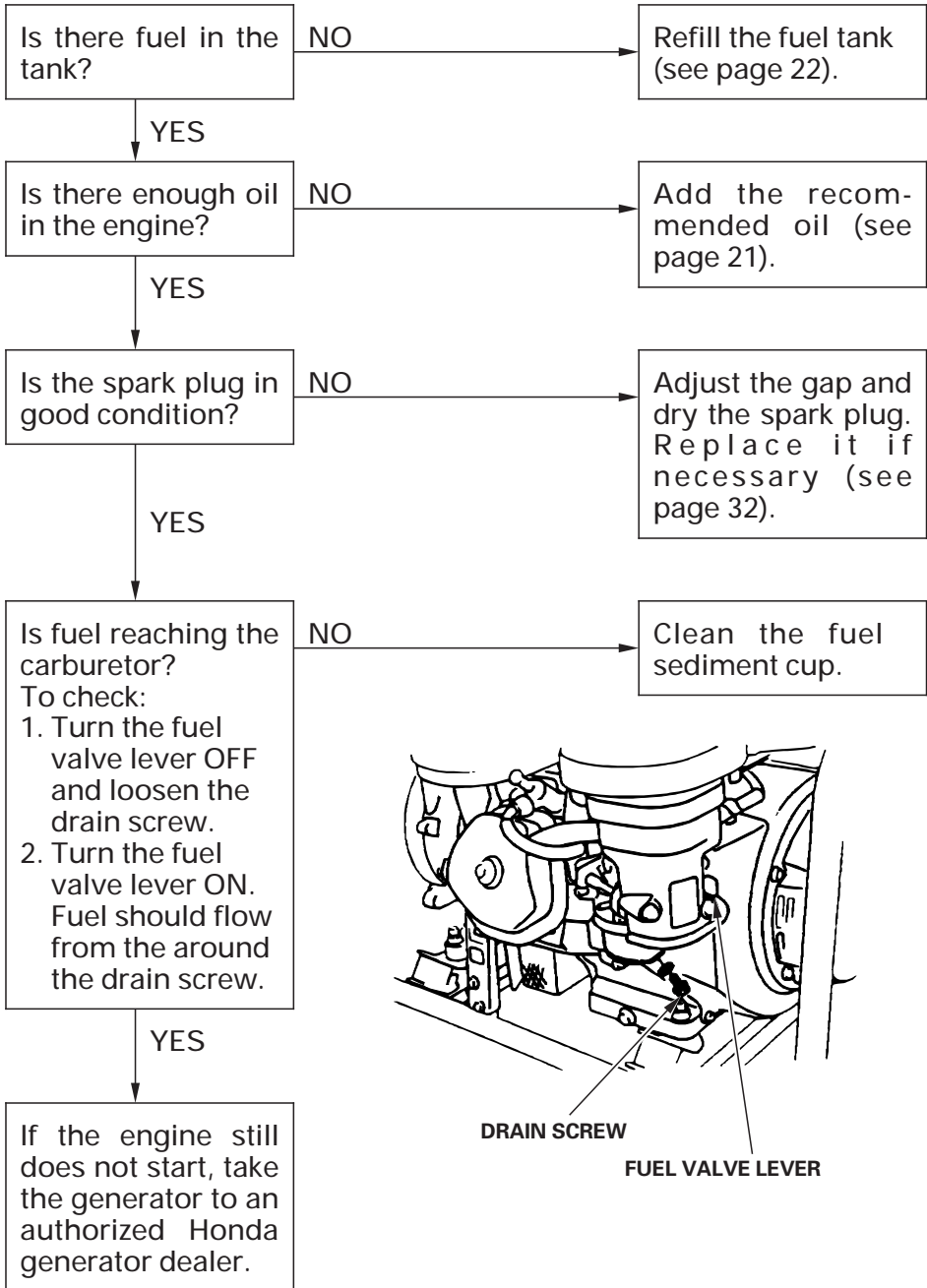

No electricity at the AC receptacles:

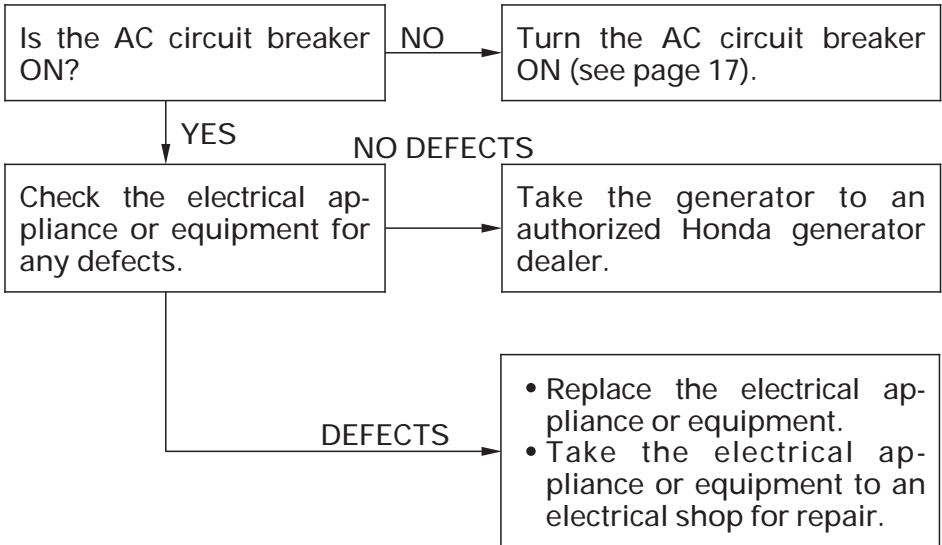

TECHNICAL INFORMATION

EMISSION CONTROL SYSTEM INFORMATION

Source of Emissions

The combustion process produces carbon monoxide, oxides of nitrogen, and hydrocarbons. Control of hydrocarbons and oxides of nitrogen are very important because, under certain conditions, they react to form photochemical smog when subjected to sunlight. Carbon monoxide does not react in the same way, but it is toxic.

Honda utilizes appropriate air/fuel ratios and other emissions control systems to reduce the emissions of carbon monoxide, oxides of nitrogen, and hydrocarbons.

Additionally, Honda fuel systems utilize components and control technologies to reduce evaporative emissions.

The U.S. and California Clean Air Acts

EPA and California regulations require all manufacturers to furnish written instructions describing the operation and maintenance of emission control systems.

The following instructions and procedures must be followed in order to keep the emissions from your Honda engine within the emission standards.

Tampering and Altering

Tampering with or altering the emission control system may increase emissions beyond the legal limit. Among those acts that constitute tampering are:

- Removal or alteration of any part of the intake, fuel, or exhaust systems.
- Altering or defeating the governor linkage or speed-adjusting mechanism to cause the engine to operate outside its design parameters.

Problems That May Affect Emissions

If you are aware of any of the following symptoms, have your engine inspected and repaired by your servicing dealer.

- Hard starting or stalling after starting.
- Rough idle.
- Misfiring or backfiring under load.
- Afterburning (backfiring).
- Black exhaust smoke or high fuel consumption.

Replacement Parts

The emission control systems on your new Honda engine were designed, built, and certified to conform with applicable emission regulations. We recommend the use of Honda Genuine parts whenever you have maintenance done. These original-design replacement parts are manufactured to the same standards as the original parts, so you can be confident of their performance. The use of replacement parts that are not of the original design and quality may impair the effectiveness of your emission control system.

A manufacturer of an aftermarket part assumes the responsibility that the part will not adversely affect emission performance. The manufacturer or rebuilder of the part must certify that use of the part will not result in a failure of the engine to comply with emission regulations.

Maintenance

Follow the *Maintenance Schedule* on page 28. Remember that this schedule is based on the assumption that your machine will be used for its designed purpose. Sustained high-load or high-temperature operation, or use in unusually wet or dusty conditions, will require more frequent service.

AIR INDEX

(Models certified for sale in California)

An Air Index Information label is applied to engines certified to an emission durability time period in accordance with the requirements of the California Air Resources Board.

The bar graph is intended to provide you, our customer, the ability to compare the emissions performance of available engines. The lower the Air Index, the less pollution.

The durability description is intended to provide you with information relating to the engine's emission durability period. The descriptive term indicates the useful life period for the engine's emission control system. See your *Emission Control System Warranty* for additional information.

Descriptive Term	Applicable to Emission Durability Period
Moderate	50 hours (0 – 80 cc, inclusive) 125 hours (greater than 80 cc)
Intermediate	125 hours (0 – 80 cc, inclusive) 250 hours (greater than 80 cc)
Extended	300 hours (0 – 80 cc, inclusive) 500 hours (greater than 80 cc) 1,000 hours (225 cc and greater)

SPECIFICATIONS

Dimensions

Model	EG5000X	
Type	Non-California type (AN type)	California type (AC type)
Power product description code	EA7	
Length	25.7 in (653 mm)	
Width	18.9 in (480 mm)	
Height	19.1 in (485 mm)	19.6 in (497 mm)
Dry weight	146.6 lbs (66.5 kg)	

Engine

Model	GX340K1
Engine type	4-stroke, overhead valve, single cylinder
Displacement [Bore x stroke]	20.6 cu-in (337 cm ³) [3.2 × 2.5 in (82.0 × 64.0 mm)]
Compression ratio	8.0 : 1
Engine speed	3,600 rpm
Cooling system	Forced air
Ignition system	Transistor magneto
Oil capacity	1.2 US qt (1.1 ℓ)
Fuel tank capacity	1.61 US gal (6.1 ℓ)
Spark plug	BPR5ES (NGK) W16EPR-U (DENSO)

Generator

Model	EG5000X	
AC output	Rated voltage	120/240 V
	Rated frequency	60 Hz
	Rated ampere	37.5/18.8 A
	Rated output	4.5 kVA
	Maximum output	5.0 kVA

Tune-up Specifications

ITEM	SPECIFICATION	MAINTENANCE
Spark plug gap	0.028 – 0.031 in (0.7 – 0.8 mm)	Refer to page: 32
Valve clearance	IN: 0.15 ± 0.02 mm (cold) EX: 0.20 ± 0.02 mm (cold)	See your authorized Honda dealer
Other specifications	No other adjustments needed.	

NOTE:

Specifications may vary according to the types, and are subject to change without notice.

CONSUMER INFORMATION

Dealer Locator Information

To find an authorized Honda Servicing Dealer anywhere in the United States:

Visit our website:
www.hondapowerequipment.com

Customer Service Information

Servicing dealership personnel are trained professionals. They should be able to answer most questions you may have. If you encounter a problem that your dealer does not solve to your satisfaction, please discuss it with the dealership's management. The Service Manager or General Manager can help. Almost all problems are solved in this way.

If you are dissatisfied with the decision made by the dealership's management, contact the Honda Power Equipment Customer Relations Office. You can write to:

American Honda Motor Co., Inc.
Power Equipment Division
Customer Relations Office
4900 Marconi Drive
Alpharetta, Georgia 30005-8847

Or telephone: (770) 497-6400 8:30 am to 7:00 pm ET

When you write or call, please give us this information:

- Model and serial number (see page 9)
- Name of dealer who sold the generator to you
- Name and address of dealer who services your generator
- Date of purchase
- Your name, address, and telephone number
- A detailed description of the problem

Honda Publications

Shop Manual

This manual covers complete maintenance and overhaul procedures. It is intended to be used by a skilled technician.

Available through your Honda dealer or through Helm Inc. at 1 888-292-5395 or visit www.hondapowerequipment.com

Parts Catalog

This manual provides complete, illustrated parts lists. Available through your Honda dealer.

Accessories Catalog

Your authorized Honda power equipment dealer offers a wide selection of accessories (optional equipment) to make your generator even more useful.

Visit www.hondapowerequipment.com and click on Generators and Welders to see the entire catalog of accessories.

WIRING DIAGRAM

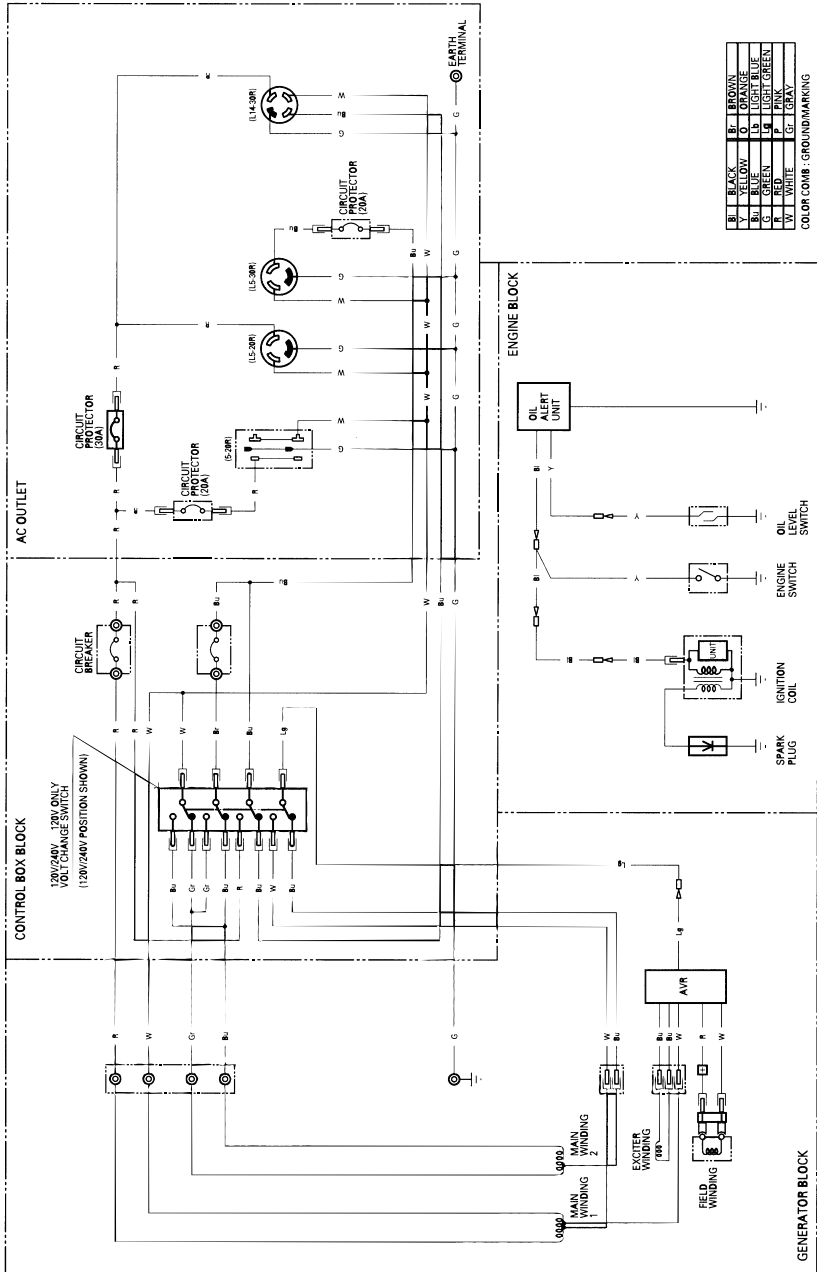

B	BLACK	BY	BROWN
Y	YELLOW	O	ORANGE
BL	BLUE	LB	LIGHT BLUE
G	GREEN	LG	LIGHT GREEN
W	WHITE	LT	LIGHT GREEN
		GR	GRAY

COLOR CODE - GROUND/MARKING

INDEX

COMPONENT IDENTIFICATION	8
CONTROLS	10
Choke Lever	11
Circuit Breaker	12
Circuit Protector	12
Engine Switch	10
Fuel Valve Lever	11
Ground Terminal	13
Oil Alert System	13
Starter Grip	10
Voltage Selector Switch (Dual Voltage System)	14
GENERATOR USE	15
AC Applications	16
AC Operation	17
AC Receptacle Selection	18
Connections to a Building Electrical System	15
Ground System	15
High Altitude Operation	20
Special Requirements	15
MAINTENANCE	26
Air Cleaner Service	30
Air Index	41
Emission Control System Information	38
Engine Oil Change	29
Fuel Sediment Cup Cleaning	31
Importance of Maintenance	26
Maintenance Safety	27
Maintenance Schedule	28
Spark Arrester Maintenance	33
Spark Plug Service	32

PRE-OPERATION CHECK	21
Engine Oil	21
Fuel Recommendations	23
Refueling	22
GENERATOR SAFETY	5
IMPORTANT SAFETY INFORMATION	6
SAFETY LABEL LOCATIONS	5
STARTING THE ENGINE	24
STOPPING THE ENGINE	25
TECHNICAL INFORMATION	38
Air Index	41
CONSUMER INFORMATION	43
Customer Service Information	43
Dealer Locator Information	43
Honda Publications	44
Specifications	42
Wiring Diagram	45
TRANSPORTING/STORAGE	34
Storage procedure	35
TROUBLESHOOTING	36

MEMO

HONDA

The Power of Dreams

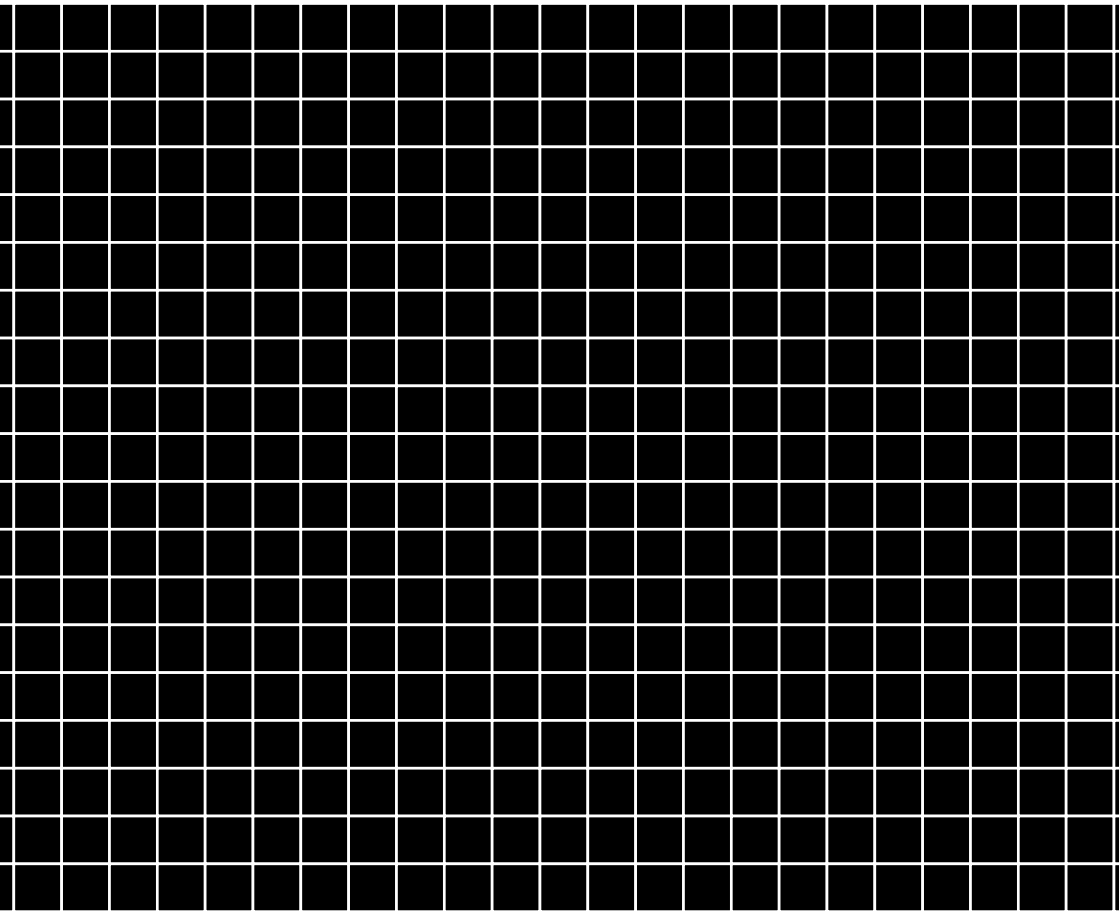

31ZC2770
00X31-ZC2-7700

EM4 K1 (AH) (英) (Y) (HC) 400.2007.12
(Hi) Printed in Japan