

**HONDA**

**Power**

**Equipment**

# Owner's Manual

## TILLER

### FRC800

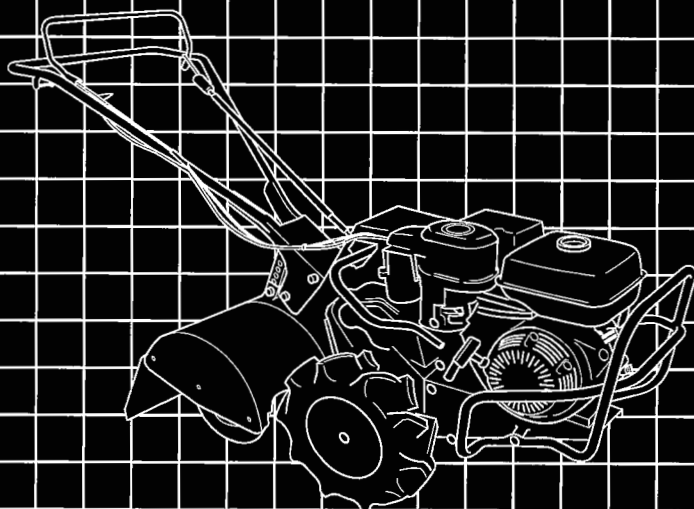



## **WARNING:**



The engine exhaust from this product contains chemicals known to the State of California to cause cancer, birth defects, or other reproductive harm.

Keep this owner's manual handy, so you can refer to it any time. This owner's manual is considered a permanent part of the tiller and should remain with the tiller if resold.

The information and specifications included in this publication were in effect at the time of approval for printing. Honda Motor Co., Ltd. reserves the right, however, to discontinue or change specifications or design at any time without notice and without incurring any obligation whatever.

# INTRODUCTION

Congratulations on your selection of a Honda tiller. We are certain you will be pleased with your purchase of one of the finest tillers on the market.

We want to help you get the best results from your new tiller and to operate it safely. This manual contains all the information on how to do that; please read it carefully.

As you read this manual, you will find information preceded by a **NOTICE** symbol. That information is intended to help you avoid damage to your tiller, other property, or the environment.

We suggest you read the warranty policy to fully understand its coverage and your responsibilities of ownership. The warranty policy is a separate document that should have been given to you by your dealer.

When your tiller needs scheduled maintenance, keep in mind that your Honda servicing dealer is specially trained in servicing Honda tillers and is supported by the parts and service divisions of American Honda. Your Honda servicing dealer is dedicated to your satisfaction and will be pleased to answer your questions and concerns.

Best Wishes,

Honda Motor Co., Ltd.

# INTRODUCTION

---

## A FEW WORDS ABOUT SAFETY

Your safety and the safety of others are very important. And using this tiller safely is an important responsibility.

To help you make informed decisions about safety, we have provided operating procedures and other information on labels and in this manual. This information alerts you to potential hazards that could hurt you or others.

Of course, it is not practical or possible to warn you about all the hazards associated with operating or maintaining a tiller. You must use your own good judgment.

You will find important safety information in a variety of forms including:

- **Safety Labels** — on the tiller.
- **Safety Messages** — preceded by a safety alert symbol  and one of three signal words: DANGER, WARNING, or CAUTION.

These signal words mean:



You WILL be KILLED or SERIOUSLY HURT if you don't follow instructions.



You CAN be KILLED or SERIOUSLY HURT if you don't follow instructions.



You CAN be HURT if you don't follow instructions.

- **Safety Headings** — such as *IMPORTANT SAFETY INFORMATION*
- **Safety Chapter** — such as *TILLER SAFETY*
- **Instructions** — how to use this tiller correctly and safely

This entire book is filled with important safety information — please read it carefully.

# CONTENTS

<b>TILLER SAFETY</b> .....	<b>5</b>
IMPORTANT SAFETY INFORMATION .....	5
SAFETY LABEL LOCATIONS .....	8
<b>CONTROLS</b> .....	<b>9</b>
COMPONENT & CONTROL LOCATIONS.....	9
CONTROLS .....	10
Fuel Valve .....	10
Choke Lever.....	10
Engine Switch .....	10
Recoil Starter.....	11
Throttle Lever.....	11
Handlebar Height Adjuster .....	11
Main Clutch Lever.....	12
Gearshift Lever.....	12
Drag Bar.....	12
<b>BEFORE OPERATION</b> .....	<b>13</b>
ARE YOU READY TO GET STARTED? .....	13
IS YOUR TILLER READY TO GO? .....	13
Check the Engine .....	14
Check the Tiller.....	14
<b>OPERATION</b> .....	<b>15</b>
SAFE OPERATING PRECAUTIONS .....	15
STARTING THE ENGINE .....	16
OPERATING THE CONTROLS FOR TILLING.....	19
HANDLING TIPS .....	23
STOPPING THE ENGINE .....	24
<b>SERVICING YOUR TILLER</b> .....	<b>25</b>
THE IMPORTANCE OF MAINTENANCE.....	25
MAINTENANCE SAFETY .....	26
MAINTENANCE SCHEDULE .....	27
REFUELING.....	28
FUEL RECOMMENDATIONS .....	28
ENGINE OIL LEVEL CHECK.....	30
ENGINE OIL CHANGE .....	31
ENGINE OIL RECOMMENDATIONS.....	32
TRANSMISSION OIL LEVEL CHECK .....	33
AIR FILTER INSPECTION.....	34

# CONTENTS

---

## **SERVICING YOUR TILLER (continued)**

AIR FILTER CLEANING .....	34
SPARK PLUG SERVICE.....	36
CLUTCH CABLE ADJUSTMENT .....	37
THROTTLE CABLE ADJUSTMENT .....	38
DRIVE BELT ADJUSTMENT .....	39
SEDIMENT CUP CLEANING .....	41
SPARK ARRESTER SERVICE.....	42
TINE REPLACEMENT .....	43
TIRE PRESSURE CHECK .....	44
TINES AND FASTENERS CHECK.....	45
<b>STORAGE.....</b>	<b>46</b>
STORAGE PREPARATION .....	46
Cleaning.....	46
Fuel .....	48
Engine Oil .....	50
STORAGE PRECAUTIONS .....	51
REMOVAL FROM STORAGE .....	51
<b>TRANSPORTING .....</b>	<b>52</b>
<b>TAKING CARE OF UNEXPECTED PROBLEMS .....</b>	<b>53</b>
ENGINE PROBLEMS .....	53
Engine Will Not Start.....	53
Engine Lacks Power.....	54
TILLING PROBLEMS .....	55
Poor Tilling Quality .....	55
<b>TECHNICAL &amp; CONSUMER INFORMATION .....</b>	<b>56</b>
TECHNICAL INFORMATION .....	56
Serial Number Locations .....	56
Carburetor Modification for High Altitude Operation.....	57
Oxygenated Fuels.....	58
Emission Control System Information.....	59
Air Index .....	61
Specifications.....	62
CONSUMER INFORMATION .....	63
Honda Publications.....	63
Customer Service Information .....	64
<b>QUICK REFERENCE INFORMATION.....</b>	<b>Inside back cover</b>

# TILLER SAFETY

## IMPORTANT SAFETY INFORMATION

Honda tillers are designed to cultivate earth outdoors. Other uses can result in injury to the operator or damage to the tiller and other property.

Most accidents can be prevented if you follow all instructions in this manual and on the tiller. The most common hazards are discussed below, along with the best way to protect yourself and others.

### Operator Responsibility

- Know how to stop the tiller quickly in case of emergency.
- Understand the use of all tiller controls.
- Be very cautious when operating the tiller in REVERSE especially if attachments are being used.
- Keep a firm hold on the handlebars. They may tend to lift during clutch engagement.
- Be sure the drag bar is in place and properly adjusted.
- Be sure that anyone who operates the tiller receives proper instruction. Do not let children operate the tiller. Keep children and pets away from the area of operation.

### Carbon Monoxide Hazards

- Exhaust contains poisonous carbon monoxide, a colorless, odorless gas. Breathing exhaust can cause loss of consciousness and may lead to death.
- If you run the tiller in a confined or even partially enclosed area, the air you breathe could contain dangerous amounts of exhaust gas. To keep exhaust gas from building up, provide adequate ventilation.

# TILLER SAFETY

---

## Fire and Burn Hazards

- The exhaust system gets hot enough to ignite some materials.
  - Keep the tiller at least 3 feet ( 1 meter) away from buildings and other equipment during operation.
  - Keep flammable materials away from the tiller.
- The muffler becomes very hot during operation and remains hot for a while after stopping the engine. Be careful not to touch the muffler while it is hot. Let the engine cool before storing the tiller indoors.

## Refuel With Care

Gasoline is extremely flammable, and gasoline vapor can explode. Allow the engine to cool if the tiller has been in operation. Refuel only outdoors in a well-ventilated area with the engine OFF. Do not overfill the fuel tank. Never smoke near gasoline, and keep other flames and sparks away. Always store gasoline in an approved container. Make sure that any spilled fuel has been wiped up before starting the engine.

## Avoid Rotating Tines

Rotating tines can cause serious cuts and even amputate body parts. Keep away from the tine area whenever the engine is running. If you need to work around the tines to clear a object accumulation or for any other reason, always shut off the engine. Disconnect the spark plug cap, and wear heavy gloves when you need to clean the tine area or handle the tines.

## Clear Tilling Area

A tine can throw rocks and other objects with enough force to cause serious injury. Before tilling, carefully inspect the area and remove all stones, sticks, bones, nails, pieces of wire, and other loose objects. Be aware if children are in the area; stop the tiller. Never operate the tines over gravel.



## **Keep Shields in Place**

Guards and shields are designed to protect you from being hit by thrown objects and to keep you from touching hot engine parts and moving components. For your safety and the safety of others, keep all shields in place when the engine is running.

## **Wear Protective Clothing**

Wearing protective clothing will reduce your risk of injury. Long pants and eye protection reduce the risk of injuries from thrown objects. Sturdy shoes with aggressive soles provide better traction.

## **Turn Engine Off When Not Operating the Tiller**

If you need to leave the tiller for any reason, even just to inspect the area ahead, always turn the engine off.

## **Slope Operation**

- When tilling on slopes, keep the fuel tank less than half full to minimize fuel spillage.
- Till across the slope (at equally spaced intervals) rather than up and down it.
- Be very careful when changing the direction of the tiller on a slope.
- Do not use the tiller on a slope of more than 10°. Before starting the engine, check that the tiller is not damaged and is in good condition. For your safety and safety of others, exercise extreme care when using the tiller on a slope.

## **Tilling Conditions**

Operate tiller only in daylight or good artificial light. Do not operate the tiller at night or under poor light conditions.

# TILLER SAFETY

## SAFETY LABEL LOCATIONS

These labels warn you of potential hazards that can cause serious injury. Read them carefully. If a label comes off or becomes hard to read, contact your Honda servicing dealer for a replacement.

**▲ WARNING** (A)  
**DRIVE BELT AND PULLEYS CAN INJURE YOU.**  
Keep guard in place during operation.

**▲ CAUTION**  
**HOT MUFFLER CAN BURN YOU.**  
Stay away if engine has been running.-

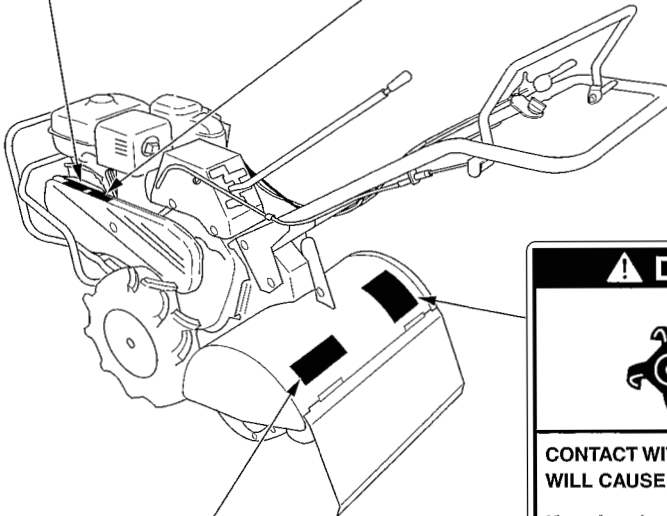

**▲ DANGER**  
  
**CONTACT WITH ROTATING TINES  
WILL CAUSE SERIOUS INJURY.**  
Keep hands and feet away while  
the engine is running. (A)

**▲ WARNING**  
**TO AVOID SERIOUS INJURY**  
• READ THE OWNER'S MANUAL CAREFULLY BEFORE OPERATION.  
• KNOW LOCATION AND FUNCTIONS OF ALL CONTROLS.  
• KEEP ALL SAFETY DEVICES AND SHIELDS IN PLACE AND WORKING.  
• NEVER ALLOW CHILDREN OR UNINSTRUCTED ADULTS TO OPERATE MACHINE.  
• SHUT OFF ENGINE BEFORE MANUALLY UNBLOCKING TINES OR MAKING REPAIRS.  
• KEEP BYSTANDERS AWAY FROM MACHINE.  
• KEEP AWAY FROM ROTATING PARTS WHILE ENGINE IS RUNNING.  
• USE EXTREME CAUTION WHEN REVERSING OR PULLING THE MACHINE TOWARDS YOU.  
• GASOLINE IS FLAMMABLE AND EXPLOSIVE. STOP ENGINE, AVOID HEAT, SPARKS, AND OPEN FLAME WHEN REFUELING.

# CONTROLS

## COMPONENT & CONTROL LOCATIONS

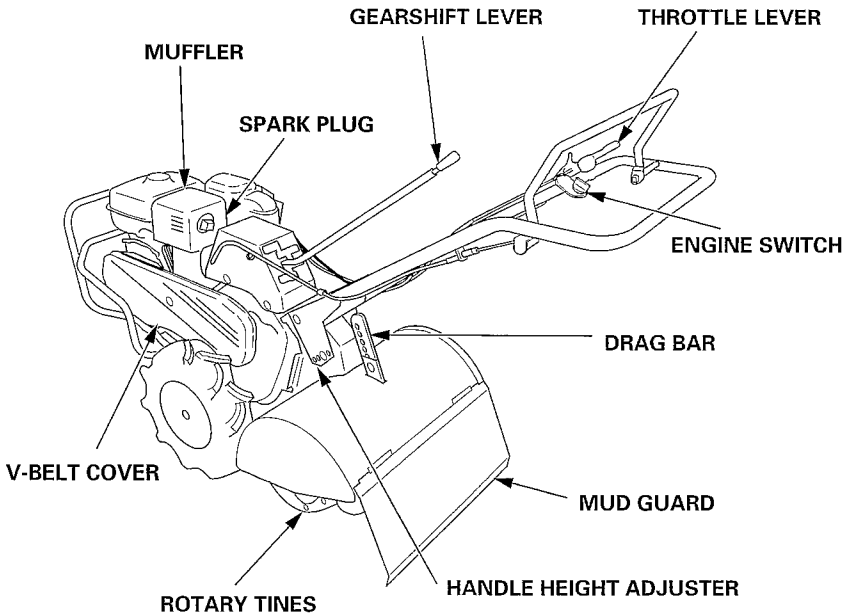
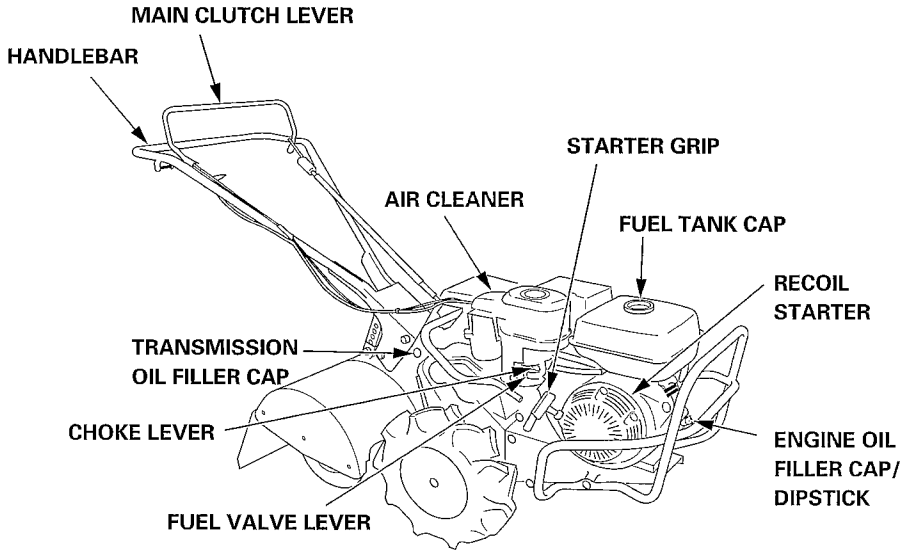

# CONTROLS

---

## CONTROLS

### Fuel Valve

The fuel valve opens and closes the connection between the fuel tank and the carburetor.

The fuel valve must be in the ON position for the engine to run.

After stopping the engine, turn the fuel valve to the OFF position.

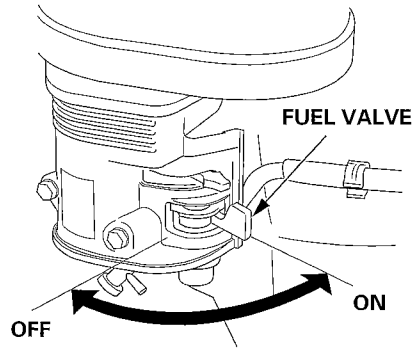

### Choke Lever

The choke lever opens and closes the choke valve in the carburetor.

The CLOSED position enriches the fuel mixture for starting a cold engine.

The OPEN position provides the correct fuel mixture for operation after starting and for restarting a warm engine.

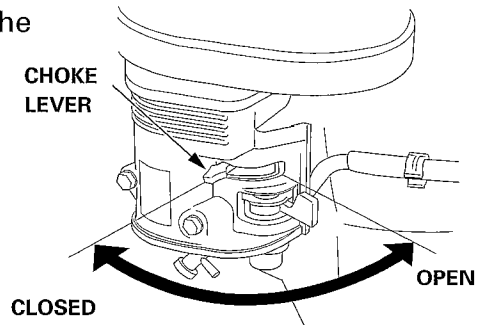

### Engine Switch

The engine switch controls the ignition system.

OFF — Stops the engine.

ON — Running position.

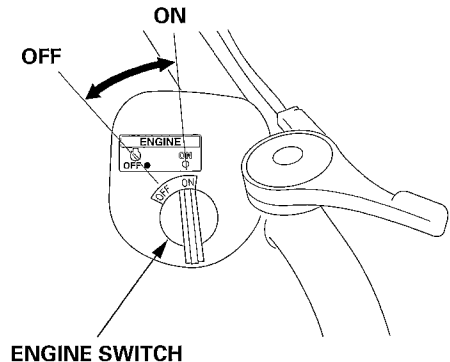

## Recoil Starter

Pulling the starter grip operates the recoil starter to crank the engine for starting.

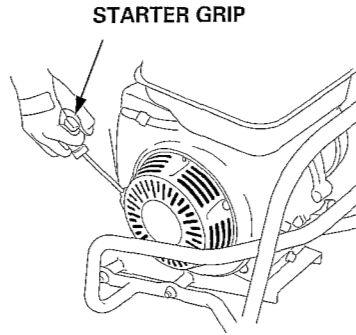

## Throttle Lever

The throttle lever controls engine speed.

Moving the throttle lever in the directions shown makes the engine run faster or slower.

Tine speed is controlled by adjusting the throttle lever. At maximum throttle position, the tines will rotate at the highest speed. Moving the throttle lever toward the idle position will decrease the tine speed.

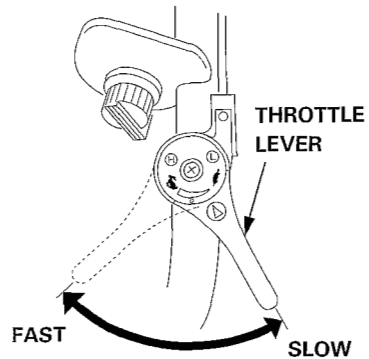

## Handlebar Height Adjuster

Handlebar height can be adjusted to match operator height.

For normal tilling, the most comfortable operator position is with the handlebars at waist height.

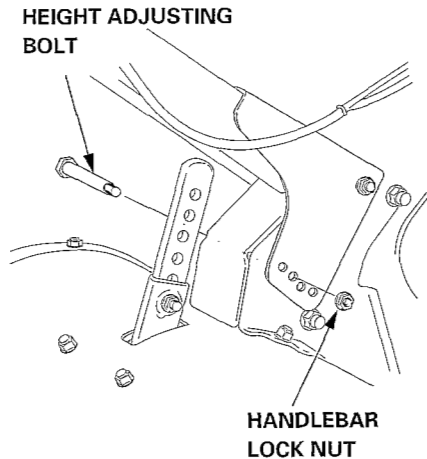

# CONTROLS

---

## Main Clutch Lever

The main clutch lever engages and disengages the transmission.

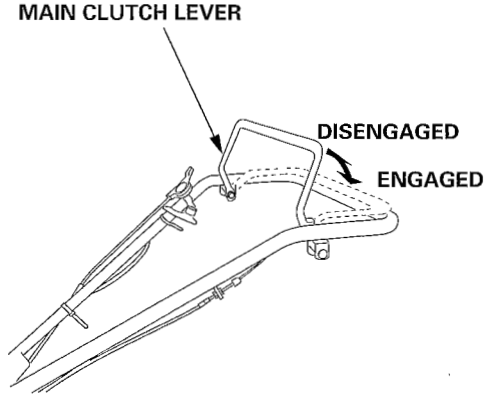

## Gearshift Lever

The transmission offers a choice of three forward speeds neutral and one reverse speed. Shift lever positions are indicated on the Change Lever Bracket.

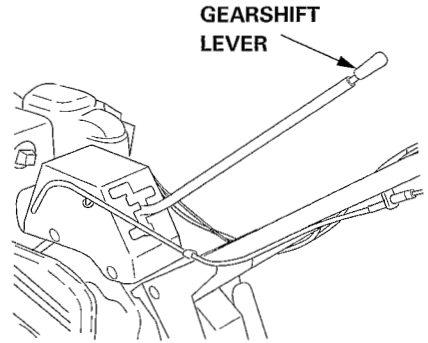

## Drag Bar

The drag bar controls tilling depth and should always be used when tilling. It enables you to compensate for the hardness of the soil. Ideal drag bar height will depend on the type of soil being tilled and soil conditions at the time of tilling. In general, the drag bar should be adjusted so that the tiller is tilted slightly backward.

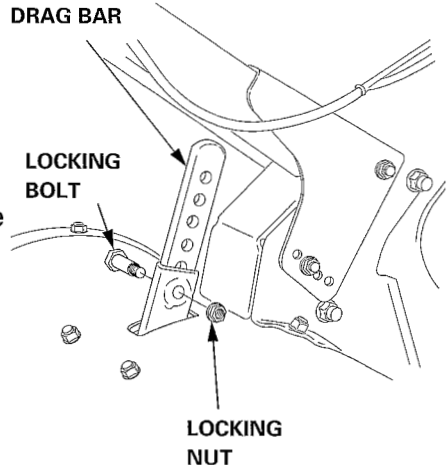

# BEFORE OPERATION

## ARE YOU READY TO GET STARTED?

Your safety is your responsibility. A little time spent in preparation will significantly reduce your risk of injury.

### Knowledge

Read and understand this manual. Know what the controls do and how to operate them.

Familiarize yourself with the tiller and its operation before you begin using it. Know how to quickly shut off the tiller in case of an emergency.

## IS YOUR TILLER READY TO GO?

For your safety, and to maximize the service life of your equipment, it is very important to take a few moments before you operate the tiller to check its condition. Be sure to take care of any problem you find, or have your servicing dealer correct it, before you operate the tiller.

### **WARNING**

Improperly maintaining this tiller, or failing to correct a problem before operation, could cause a malfunction in which you could be seriously injured.

Always perform a preoperation inspection before each operation, and correct any problem.

# **BEFORE OPERATION**

---

Do not place flammable objects close to the engine.

Before beginning your preoperation checks, be sure the tiller is on a level surface and the engine switch is in the OFF position.

## **Check the Engine**

Check the oil level (see page 30).

Check the air filter (see page 34). A dirty air filter will restrict air flow to the carburetor, reducing engine and tiller performance.

Check the fuel level (see page 28). Starting with a full tank will help to eliminate or reduce operating interruptions for refueling.

## **Check the Tiller**

Check the transmission oil (see page 33).



# OPERATION

## SAFE OPERATING PRECAUTIONS

Before operating the tiller for the first time, please review both the *TILLER SAFETY* chapter and the chapter titled *BEFORE OPERATION*.

For your safety, avoid starting or operating the tiller in an enclosed area such as a garage. Your tiller's exhaust contains poisonous carbon monoxide gas which can collect rapidly in an enclosed area and cause illness or death.

### **WARNING**

Carbon monoxide gas is toxic. Breathing it can cause unconsciousness and even kill you.

Avoid any enclosed areas or activities that expose you to carbon monoxide.

# OPERATION

## STARTING THE ENGINE

Refer to *Safe Operating Precautions* on Page 15.

### **⚠ WARNING**

Tines are sharp and spin fast.

Spinning tines can cut you severely and can amputate body parts.

- Wear protective footwear.
- Keep your hands and feet away from the tines while the engine is running.
- Stop the engine before performing any adjustment, inspection, or maintenance.

1. Turn the fuel valve lever to the ON position. Check that the fuel drain screw is tightened securely.

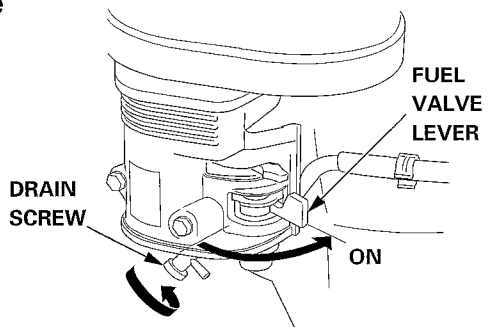

2. Move the choke lever to the CLOSED position to start a cold engine.

Leave the choke lever in the OPEN position to restart a warm engine.

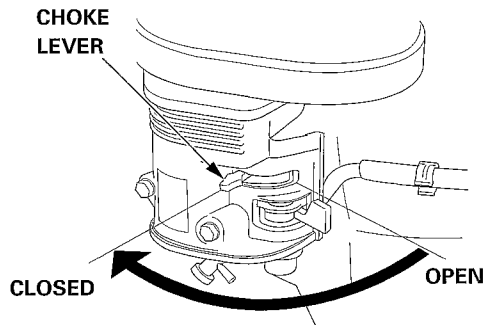

3. Turn the engine switch to the ON position.

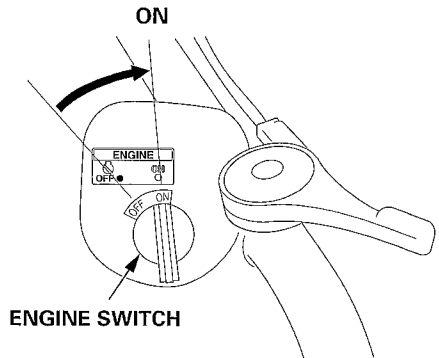

4. Move the throttle lever away from the SLOW position, about 1/3 of the way toward the FAST position.

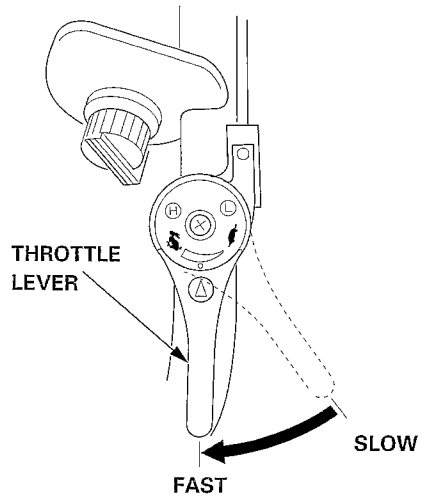

5. Pull the starter grip lightly until you feel resistance, then pull briskly.

Do not allow the starter grip to snap back against the engine. Return it gently to prevent damage to the starter.

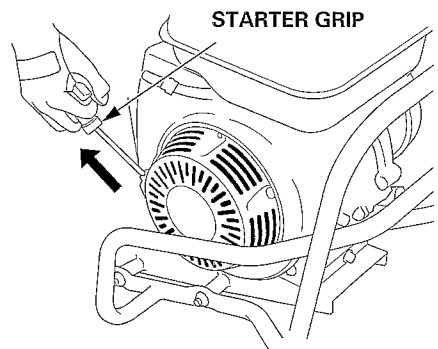

# OPERATION

---

6. If the choke lever was moved to the CLOSED position to start the engine, gradually move it to the OPEN position as the engine warms up.

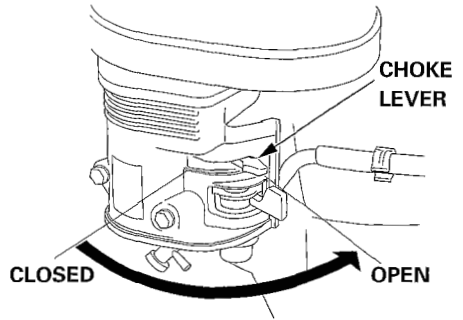

## OPERATING THE CONTROLS FOR TILLING

If the tines dig in but the machine will not move forward, move the handlebars from side-to-side.

### Handlebar Height Adjustment

Stop the engine before adjusting the handlebar height.

To adjust the handlebar height, loosen the handlebar height adjuster, select the appropriate holes and tighten it.

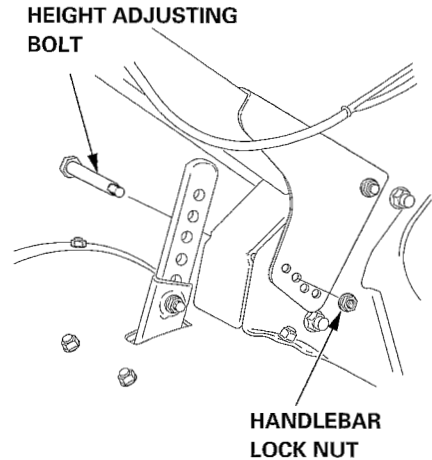

### Clutch

When the main clutch lever is squeezed, the clutch is engaged, and power is transmitted to the transmission.

When the lever is released, the clutch is disengaged, and power is not transmitted.

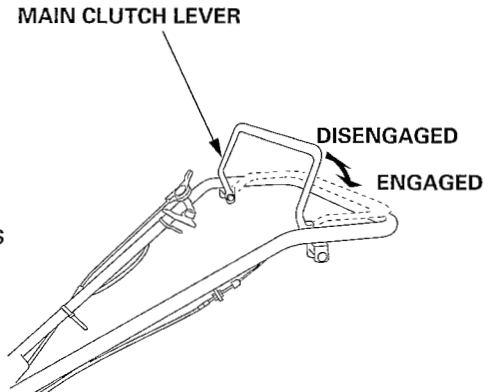

# OPERATION

## Forward Gear Selection

1. Return the throttle lever to the slowest position.
2. Release the clutch lever to disengage the clutch.
3. Move the shift lever to the desired gear position.

The tines will only operate when the shift lever is positions in the yellow zone. If the shift lever will not engage the desired gear, squeeze the clutch lever and move the tiller slightly to reposition the gears.

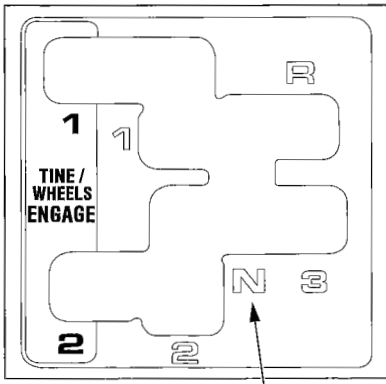

NEUTRAL POSITION

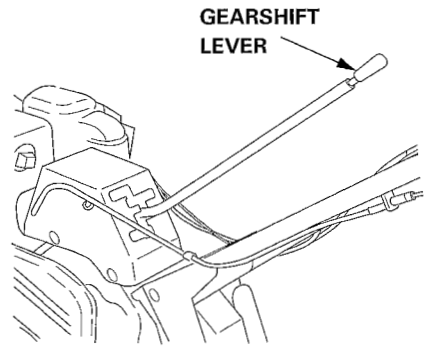

Gear Selection Table (When engine speed is 3,400 rpm)

Gear position	Tiller speed	*Tine speed	Suitable work
1	0.18 m/s	—	Moving tiller, loading tiller onto a truck, taking tiller on or off field
2	0.35 m/s	—	Moving tiller, loading tiller onto a truck, taking tiller on or off field
3	1.28 m/s	—	Moving tiller
TINE/WHEELS ENGAGE 1	0.18 m/s	219 rpm	Tilling, ground breaking, weeding
TINE/WHEELS ENGAGE 2	0.36 m/s	219 rpm	Tilling, ground breaking, weeding
R	0.21 m/s	—	Moving tiller, loading/unloading tiller from a truck, taking tiller on or off field

\*Tiller speed applies when standard tires are used.

## **Reverse Gear Operation**

Use the reverse gear only when it is necessary to move the tiller away from an obstacle.

1. Check the area behind you and make sure it is clear of any obstacles.
2. Move the throttle to the SLOW position.
3. Make sure the main clutch lever is released. Move the shift lever to the REVERSE position.
4. Engage the main clutch lever and carefully walk the tiller backwards. Be prepared to release the main clutch lever quickly.
5. Release the main clutch lever, lower the handle bar, and move the shift lever out of the REVERSE position when done.

# OPERATION

---

## Tiling Depth Adjustment

The drag bar is used to control the tilling depth, which can be adjusted by loosening the locking bolt and sliding the drag bar up or down as necessary.

During operation, if the machine jerks forward while tilling, press down on the handle bars. This will cause the drag bar to dig more deeply into the soil.

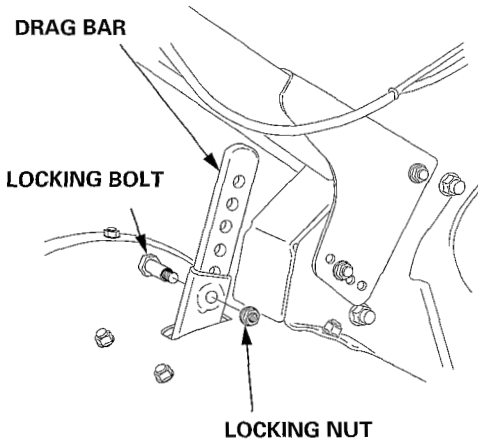



## HANDLING TIPS

- Adjust the handle bar height to a comfortable position (waist height for normal tilling).
- The drag bar should always be used when tilling. It enables you to compensate for the hardness of the soil. The ideal height of the drag bar will depend on the type of soil being tilled and soil conditions at the time of tilling. In general, however, the drag bar should be adjusted so that the tiller is tilted slightly backward.
- If the machine jerks forward while tilling, press down on the handle bars. This will cause the drag bar to dig more deeply into the soil.
- If tines dig in but the machine will not move forward, move the handle bars from side to side.
- Stop the tines before crossing gravel drives, walks, or roads. Stay alert for hidden hazards or traffic.
- Stop the engine immediately if the tiller vibrates abnormally. Check the tiller for damage or loose parts, and repair or replace them before using the tiller again. Vibration is usually a sign of trouble.

# OPERATION

## STOPPING THE ENGINE

To stop the engine in an emergency, simply turn the engine switch to the OFF position. Under normal conditions, use the following procedure.

1. Release the main clutch lever to the DISENGAGED position, and move the shift lever to the neutral position.

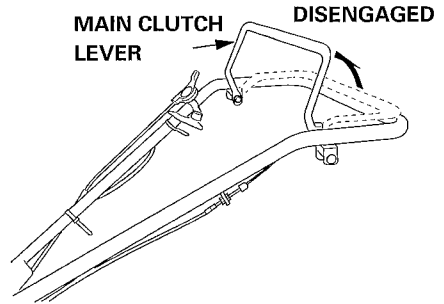

2. Move the throttle lever to the slowest position.

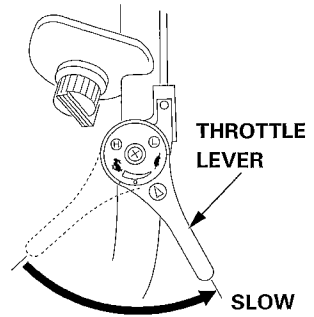

3. Turn the engine switch to the OFF position.

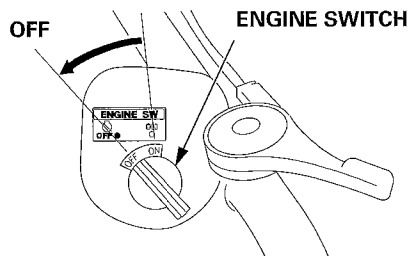

4. Turn the fuel valve lever to the OFF position.

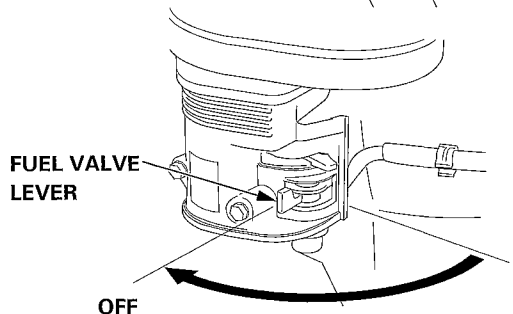

# SERVICING YOUR TILLER

## THE IMPORTANCE OF MAINTENANCE

Good maintenance is essential for safe, economical, and trouble-free operation. It will also help reduce air pollution.

To help you properly care for your tiller, the following pages include a maintenance schedule, routine inspection procedures, and simple maintenance procedures using basic hand tools. Other service tasks that are more difficult, or require special tools, are best handled by professionals and are normally performed by a Honda technician or other qualified mechanic.

The maintenance schedule applies to normal operating conditions. If you operate your tiller under unusual conditions, (such as sustained high-load or high-temperature operation, or use in dusty conditions), consult your servicing dealer for recommendations applicable to your individual needs and use.

### **WARNING**

Improper maintenance, or failure to correct a problem before operation, can cause a malfunction in which you can be seriously hurt or killed.

Always follow the inspection and maintenance recommendations and schedules in this owner's manual.

Remember that your servicing dealer knows your tiller best and is fully equipped to maintain and repair it.

To ensure the best quality and reliability, use only new, genuine Honda parts or their equivalents for repair and replacement.

**Maintenance, replacement, or repair of the emission control devices and systems may be performed by any engine repair establishment or individual, using parts that are "certified" to EPA standards.**

# SERVICING YOUR TILLER

---

## MAINTENANCE SAFETY

Some of the most important safety precautions follow. However, we cannot warn you of every conceivable hazard that can arise in performing maintenance. Only you can decide whether or not you should perform a given task.

### **WARNING**

Failure to properly follow maintenance instructions and precautions can cause you to be seriously hurt or killed.

Always follow the procedures and precautions in the owner's manual.

## Safety Precautions

- Make sure the engine is off before you begin any maintenance or repairs. This will eliminate several potential hazards:
  - **Carbon monoxide poisoning from engine exhaust.**  
Be sure there is adequate ventilation whenever you operate the engine.
  - **Burns from hot parts.**  
Let the engine and exhaust system cool before touching.
  - **Injury from moving parts.**  
Do not run the engine unless instructed to do so.
- Read the instructions before you begin, and make sure you have the tools and skills required.
- To reduce the possibility of fire or explosion, be careful when working around gasoline. Use only a nonflammable solvent, not gasoline, to clean parts. Keep cigarettes, sparks, and flames away from all fuel-related parts.
- Disconnect the spark plug cap and wear heavy gloves when working near the belts, or tine blades.

# SERVICING YOUR TILLER

## MAINTENANCE SCHEDULE

REGULAR SERVICE PERIOD (3)		Each use	First month or 20 hrs.	Every 3 months or 50 hrs.	Every 6 months or 100 hrs.	Every year or 300 hrs.
ITEM	Perform at every Indicated month or operating hour Interval, whichever comes first.					
• Engine oil	Check level	<input type="radio"/>				
	Change		<input type="radio"/>		<input type="radio"/>	
• Transmission oil	Check level	<input type="radio"/>				
	Clean			<input type="radio"/> (1)		
	Replace					<input type="radio"/> *
• Clutch cable	Adjust		<input type="radio"/>		<input type="radio"/>	
• Belt tension	Adjust		<input type="radio"/>		<input type="radio"/>	
• Spark plug	Check-adjust				<input type="radio"/>	
	Replace					<input type="radio"/>
• Sediment cup	Clean				<input type="radio"/>	
• Spark arrester (Optional parts)	Clean				<input type="radio"/>	
• Throttle cable	Adjust					<input type="radio"/>
• Idle speed	Check-adjust					<input type="radio"/> (2)
• Valve clearance	Check-adjust					<input type="radio"/> (2)
• Combustion chamber	Clean	After every 500 hrs. (2)				
• Fuel tank & filter	Clean				<input type="radio"/> (2)	
• All fasteners (for tightness)	Check-tighten	Initial 10 hrs.				
• Fuel tube	Check	Every 2 years (Replace if necessary) (2)				

• Emission related items.

\* Replace the paper element only.

(1) Service more frequently when used in dusty areas.

(2) These items should be serviced by your servicing dealer, unless you have the proper tools and are mechanically proficient. Refer to the Honda shop manual for service procedures.

(3) For commercial use, log hours of operation to determine proper maintenance intervals.

# SERVICING YOUR TILLER

---

## REFUELING

Fuel tank capacity: 1.19 US gal (4.5ℓ)

With the engine stopped, remove the fuel tank cap and check the fuel level. Refill the tank if the fuel level is low. Do not fill above the fuel level mark.

### **WARNING**

Gasoline is highly flammable and explosive.

You can be burned or seriously injured when handling fuel.

- Stop the engine and keep heat, sparks, and flame away.
- Refuel only outdoors.
- Wipe up spills immediately.

Refuel in a well-ventilated area before starting the engine. If the engine has been running, allow it to cool. Refuel carefully to avoid spilling fuel. Do not fill the fuel tank above the fuel level mark. After refueling, tighten the fuel tank cap securely.

Never refuel the engine inside a building where gasoline fumes may reach flames or sparks. Keep gasoline away from appliance pilot lights, barbecues, electric appliances, power tools, etc.

Spilled fuel is not only a fire hazard, it causes environmental damage. Wipe up spills immediately.

## FUEL RECOMMENDATIONS

**Use unleaded gasoline with a pump octane rating of 86 or higher.**

This engine is certified to operate on unleaded gasoline. Unleaded gasoline produces fewer engine and spark plug deposits and extends exhaust system life.

## SERVICING YOUR TILLER

---

Never use stale or contaminated gasoline or an oil/gasoline mixture. Avoid getting dirt or water in the fuel tank.

Occasionally you may hear light “spark knock” or “pinging” (metallic rapping noise) while operating under heavy loads. This is no cause for concern.

If spark knock or pinging occurs at a steady engine speed, under normal load, change brands of gasoline. If spark knock or pinging persists, see an authorized Honda servicing dealer.

### **NOTICE**

*Running the engine with persistent spark knock or pinging can cause engine damage.*

Running the engine with persistent spark knock or pinging is misuse, and the *Distributor's Limited Warranty* does not cover parts damaged by misuse.

# SERVICING YOUR TILLER

---

## ENGINE OIL LEVEL CHECK

Check the engine oil level with the tiller on a level surface and the engine stopped.

1. Remove the engine oil filler cap/dipstick and wipe it clean.
2. Insert and remove the engine oil filler cap/dipstick without screwing it into the oil filler neck. Check the oil level shown on the engine oil filler cap/dipstick.
3. If the oil level is low, fill to the top of the oil filler neck with the recommended oil (see page 32).
4. Screw in the engine oil filler cap/dipstick securely.

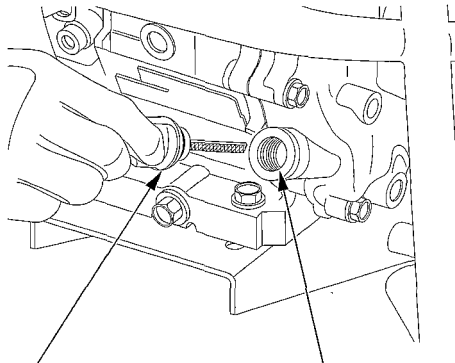

ENGINE OIL  
FILLER CAP/DIPSTICK

OIL FILLER NECK

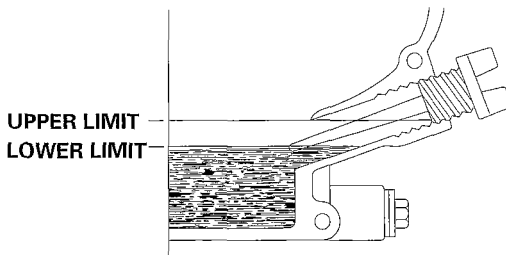

UPPER LIMIT  
LOWER LIMIT



## ENGINE OIL CHANGE

Drain the oil while the engine is warm to assure rapid and complete draining.

1. Place a suitable container below the engine to catch the used oil, then remove the engine oil filler cap/dipstick, drain plug and sealing washer.
2. Allow the used oil to drain completely, then reinstall the drain plug and sealing washer. Tighten the plug securely.

### NOTICE

*Improper disposal of engine oil can be harmful to the environment. If you change your own oil, please dispose of the used oil properly. Put it in a sealed container and take it to a recycling center. Do not discard it in a trash bin or dump it on the ground.*

3. With the tiller in a level position, fill to the outer edge of the oil filter hole with the recommended oil (see page 32).

**Oil Capacity:** 1.16 US qt (1.10ℓ)

### NOTICE

*Running the engine with a low oil level is misuse and can cause engine damage. This type of damage is not covered by the Distributors Limited Warranty.*

4. Screw in the engine oil filler cap/dipstick securely.

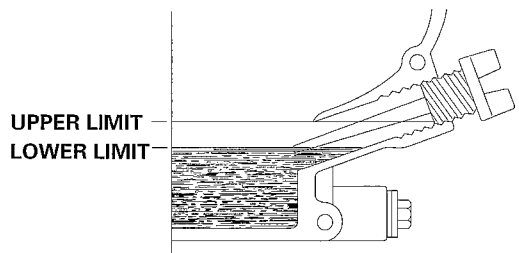
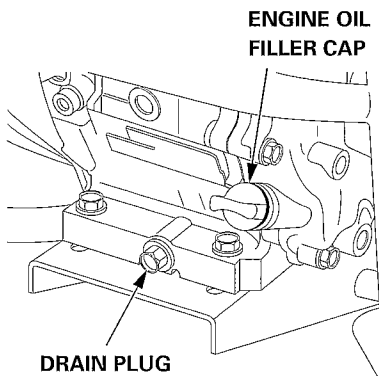

# SERVICING YOUR TILLER

---

## ENGINE OIL RECOMMENDATIONS

Oil is a major factor affecting performance and service life. Use a 4-stroke automotive detergent oil.

SAE 10W-30 is recommended for general use. Other viscosities shown in the chart may be used when the average temperature in your area is within the recommended range.

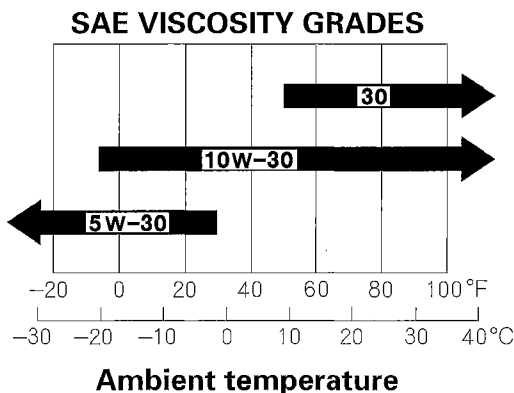

The SAE oil viscosity and service classification are in the API label on the oil container. Honda recommends that you use API SERVICE category SJ oil.

# SERVICING YOUR TILLER

## TRANSMISSION OIL LEVEL CHECK

Check the transmission oil level with the tiller on a level surface and the engine stopped.

1. Remove the transmission oil level check bolt. The oil should be level with the lower edge of the oil filler hole.
2. Remove the transmission oil filler cap and add the same oil as recommended for the engine (see page 32), if the level is low.
3. Reinstall oil filler cap and tighten the oil level check bolt securely.

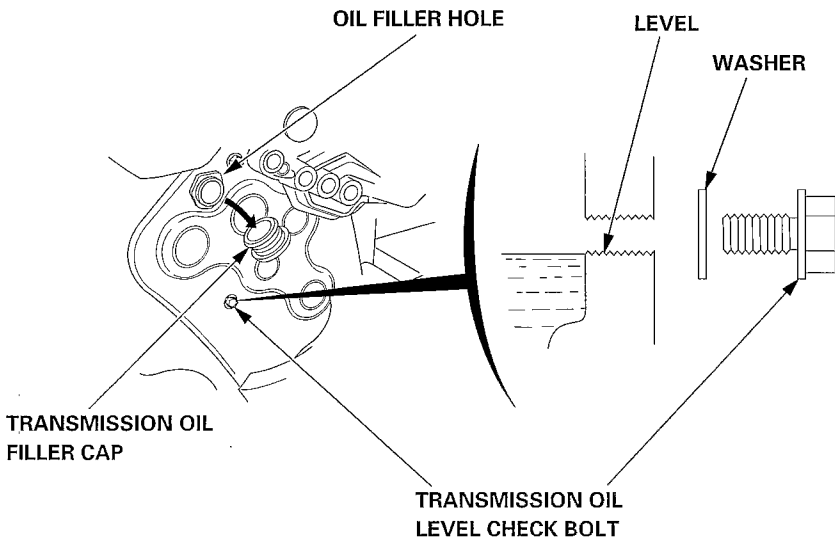

# SERVICING YOUR TILLER

## AIR FILTER INSPECTION

1. Unscrew the wing nut and remove the air cleaner cover. Check the air filter to be sure it is clean and in good condition.
2. If the air filter are dirty, clean them as described on page 34. Replace the air filter if they are damaged.
3. Reinstall the air cleaner cover, and tighten the wing nut securely.

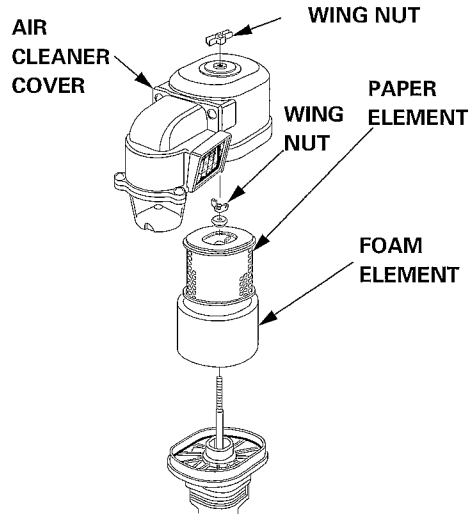

### NOTICE

*Operating the engine without the air filter, or with damaged air filter, will allow dirt to enter the engine, causing rapid engine wear. This type of damage is not covered by the Distributor's Limited Warranty.*

## AIR FILTER CLEANING

A dirty air filter will restrict air flow to the carburetor, reducing engine performance. If you operate the tiller in very dusty areas, clean the air filter more frequently than specified in the *Maintenance Schedule*.

1. Remove the wing nut and air cleaner cover.
2. Remove the wing nut and grommet, and air filter elements and separate them.
3. Carefully check both filter elements for holes or tears and replace if necessary.

# SERVICING YOUR TILLER

4. Clean both filter elements, if they are to be reused.

**Foam element:** Clean in warm soapy water, rinse and allow to dry thoroughly, or clean with a high flash point solvent and allow to dry.

Dip the element in clean engine oil and squeeze out all the excess oil.

Excess oil will restrict air flow through the foam element and may smoke at the engine start.

**Paper element:** Tap the filter element several times to remove dirt or blow compressed air (not exceeding 207 kPa, 2.1 kgf/cm<sup>3</sup>, 30 psi) through the filter from the clean side that faces the engine. Never try to brush off dirt; brushing will force dirt into the fibers.

5. Install the foam element onto the paper element.
6. Wipe dirt from the inside of the air cleaner cover using a moist rag.

Remove the five 5 × 16.5 mm pan screws and remove the pre air cleaner guide and case.

Clean air cleaner cover and case. Assemble the pre air cleaner case and guide by aligning tab of the case with the groove of the case cover.

7. Reinstall the filter elements and grommet and tighten the wing nut. Install the air cleaner cover and tighten the wing nut.

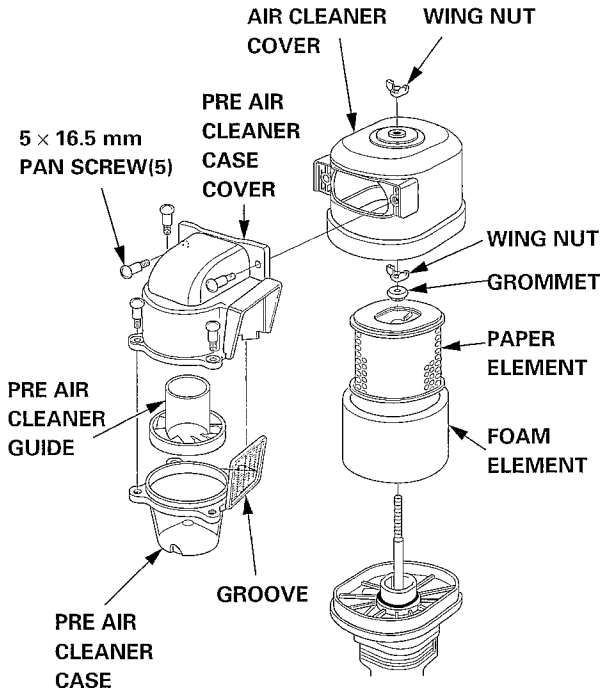

# SERVICING YOUR TILLER

---

## SPARK PLUG SERVICE

Recommended spark plug: BPR6ES (NGK), W20EPR-U (DENSO)

### NOTICE

*Incorrect spark plugs can cause engine damage.*

1. Disconnect the spark plug cap, and remove any dirt from around the spark plug area.
2. Remove the spark plug with a 13/16-inch spark plug wrench.

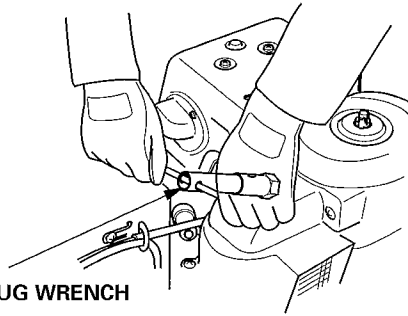

SPARK PLUG WRENCH

3. Inspect the spark plug. Replace it if the electrodes are worn, or if the insulator is cracked or chipped. Clean the spark plug if you are going to reuse it.
4. Measure the spark plug electrode gap with a suitable gauge. The gap should be 0.028 - 0.031 in (0.70 - 0.80 mm). Correct the gap, if necessary, by carefully bending the side electrode.
5. Install the spark plug carefully, by hand, to avoid cross-threading.
6. After the spark plug seats, tighten with a 13/16-inch spark plug wrench to compress the washer.

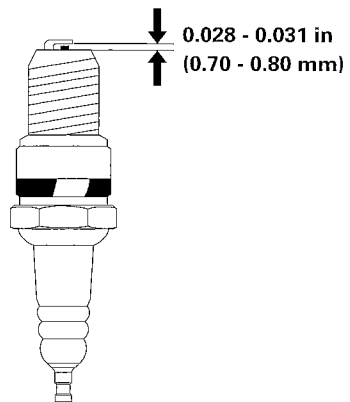

# SERVICING YOUR TILLER

If reinstalling a used spark plug, tighten 1/8 - 1/4 turn after the spark plug seats.

If installing a new spark plug, tighten 1/2 turn after the spark plug seats.

## NOTICE

*A loose spark plug can overheat and damage the engine. Overtightening the spark plug can damage the threads in the cylinder head.*

7. Attach the spark plug cap.

## CLUTCH CABLE ADJUSTMENT

Adjust the handlebar height on the third hole from the bottom (page 19).

There should be 3/16 - 3/8 inches (5 - 10 mm) of free play at the lever end. If lever adjustment is incorrect, loosen the lock nut and turn the adjusting nut in or out just enough to set the correct free play. Do not overtighten.

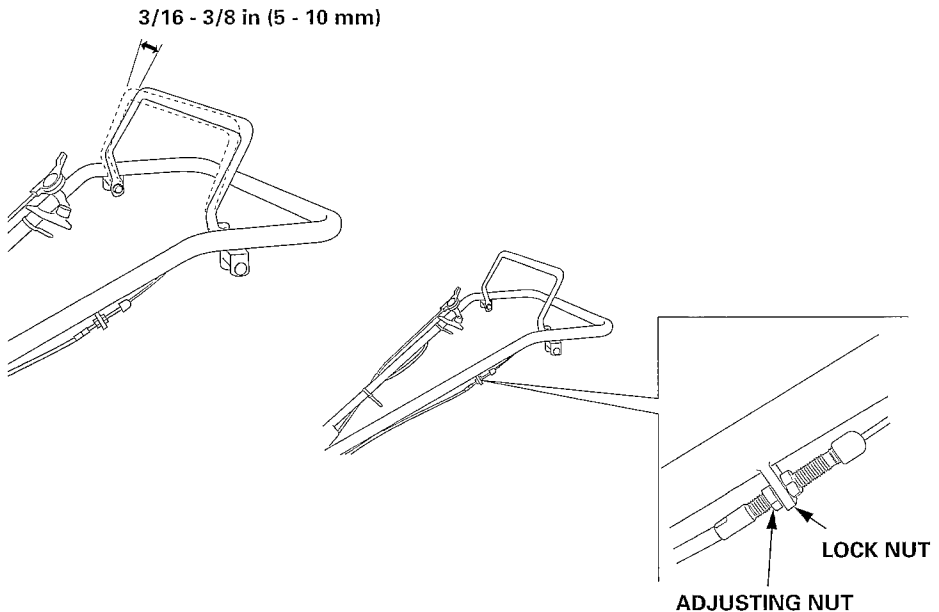

# SERVICING YOUR TILLER

---

## THROTTLE CABLE ADJUSTMENT

Measure the free play at the lever tip.

Free play: 3/16 - 3/8 in (5 - 10 mm)

If the free play is incorrect, loosen the lock nut and turn the adjusting nut in or out as required.

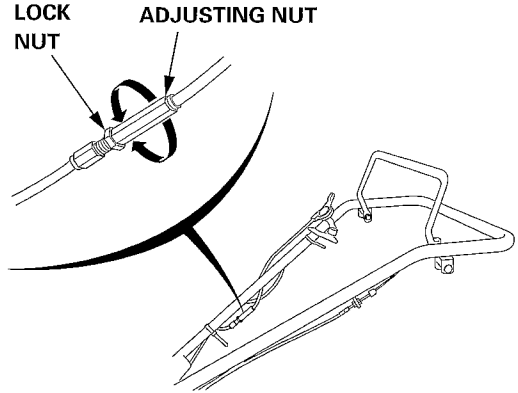
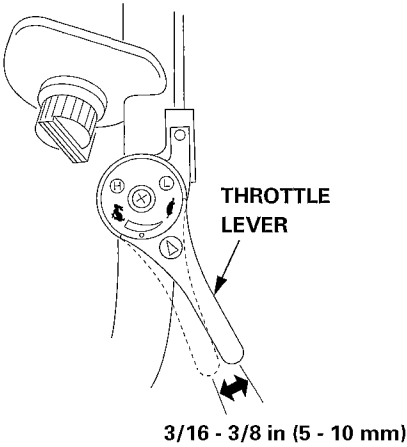



## DRIVE BELT ADJUSTMENT

1. Stop the engine, remove the spark plug cap.
2. Adjust the handlebar height on the third hole from the bottom (page 19).
3. Adjust the clutch cable (page 37).  
Remove the belt cover. Hold the clutch lever in the ENGAGED position. Pinch the upper and lower parts of the belt together with both hands five or six times.

Belt tension is correct when the distance from the top of the belt to the top of the tension roller is 1.77 - 1.97 in (45 - 50 mm) when the clutch is engaged.

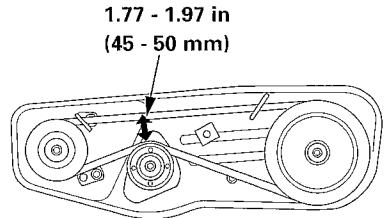
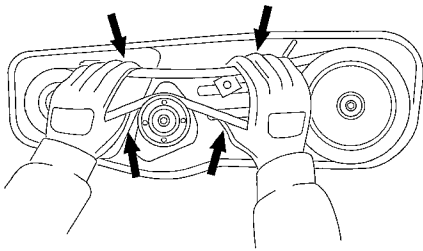

4. To adjust, loosen the four engine mounting bolts and the belt stopper attaching two bolts (front side) and move the engine forward or backward to get proper tension on the belt.

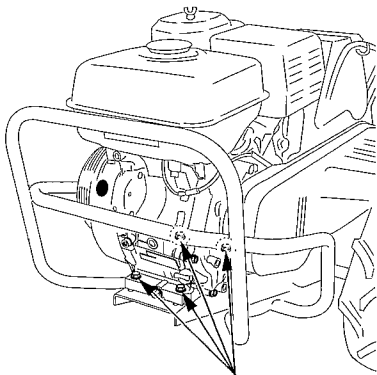

ENGINE MOUNTING BOLTS

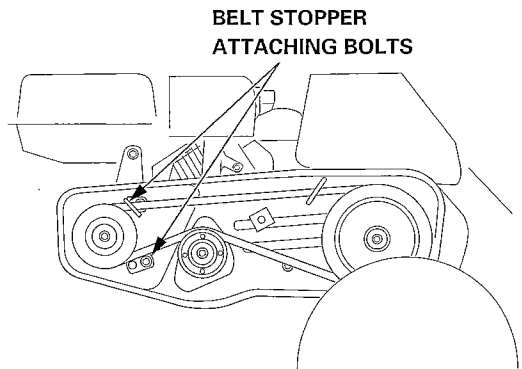

BELT STOPPER  
ATTACHING BOLTS

# SERVICING YOUR TILLER

## NOTICE

*During adjustment, line up the groove of the engine-side pulley and that of the transmission-side pulley. If they are not aligned, the belt may come off or will wear prematurely.*

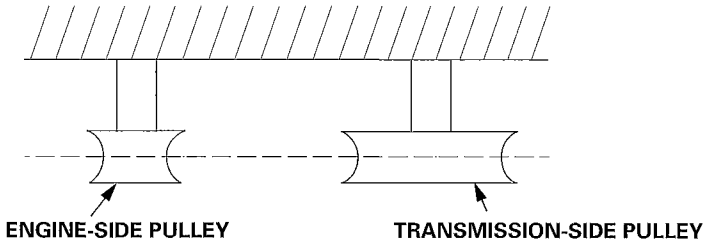

5. Loosen the belt stopper attaching bolts. Adjust the clearance between the belt stopper and the belt as illustrated with the clutch lever squeezed.

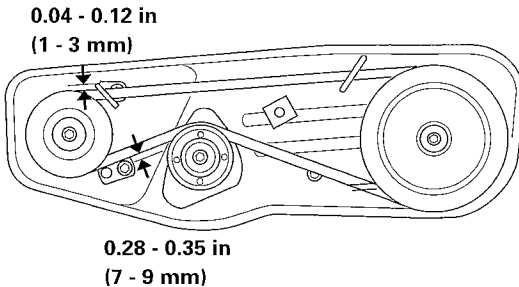

6. After adjustment has been completed, fasten the nut securely.
7. Install the belt cover.

After checking or adjusting the drive belt, be sure to reinstall the belt cover. The cover is designed to help shield you from the moving belt and pulleys.

## **!** WARNING

Contact with the moving belt or pulleys may cause you or your clothing to get caught in the moving parts resulting in serious accident or injury.

Always keep the belt cover installed when operating the tiller.

## SEDIMENT CUP CLEANING

1. Turn the fuel valve to the OFF position.
2. Remove the sediment cup with a 10 mm wrench.
3. Empty the sediment cup, and wash it in nonflammable solvent.
4. Inspect and reinstall the O-ring. Replace the O-ring if it is damaged.
5. Install the sediment cup, and tighten it securely.
6. Turn the fuel valve to the ON position, and check for leaks.

### **⚠ WARNING**

Gasoline is highly flammable and explosive.

You can be burned or seriously injured when handling fuel.

- Stop the engine and keep heat, sparks, and flame away.
- Refuel only outdoors.
- Wipe up spills immediately.

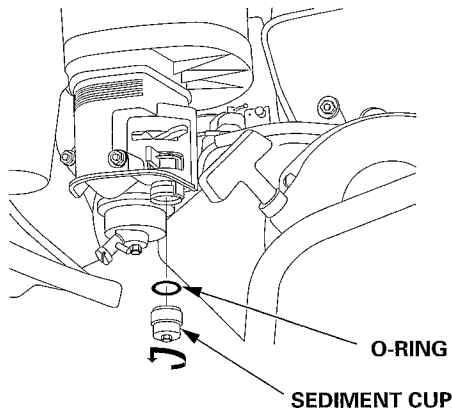

# SERVICING YOUR TILLER

---

## SPARK ARRESTER SERVICE

Your engine is not factory-equipped with a spark arrester. In some areas, it is illegal to operate an engine without a spark arrester. Check local laws and regulations. A spark arrester is available from authorized Honda servicing dealers.

The spark arrester must be serviced every 6 months or 100 hours to keep it functioning as designed.

If the engine has been running, the muffler will be very hot. Allow the muffler to cool before servicing the spark arrester.

1. Remove the mounting bolt.
2. Remove the two 8 mm nuts and remove the muffler from the cylinder.
3. Remove the two 4 mm screws from the muffler deflector, and remove the muffler deflector.
4. Remove the six 5 mm screws from the muffler protector, and remove the muffler protector.
5. Remove the special screw from the spark arrester, and remove the spark arrester from the muffler.

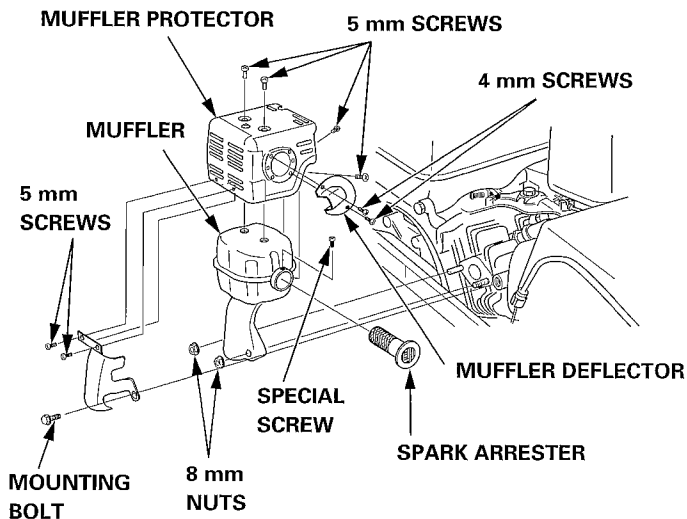

# SERVICING YOUR TILLER

- Use a brush to remove carbon deposits from the spark arrester screen. Be careful to avoid damaging the screen. The spark arrester must be free of breaks and holes. Replace the spark arrester if it is damaged.

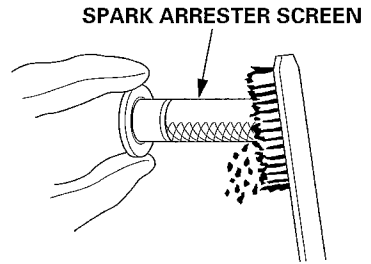

- Install the spark arrester and muffler protector, in the reverse order of disassembly.

## TINE REPLACEMENT

Use genuine Honda replacement tines or their equivalent. Wear heavy gloves to protect your hands.

### Nut and bolt positions

For rotary tines A/B and E'/F':

Tighten the bolts from outside in.

Make sure to install the tine plates.

For other tines: Tighten the bolts from inside out.

### Tine positions

Rotary tines C/D and C'/D':

Toward outside

Others: Toward inside

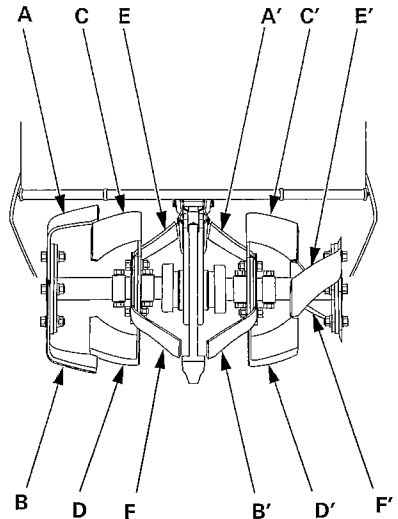
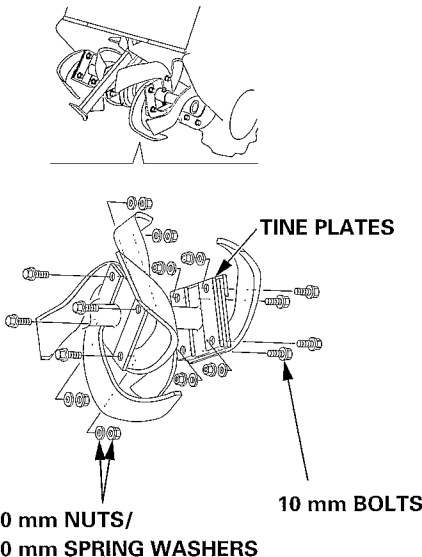

# SERVICING YOUR TILLER

---

## TIRE PRESSURE CHECK

Check the tire pressure. Improper inflation can reduce both tire life and load carrying capacity.

Make sure the clevis pin and lock pin are securely installed.

Tire size: 4.00 - 7

Tire pressure: 120 kPa (1.2 kg/cm<sup>2</sup>, 17.1 psi)

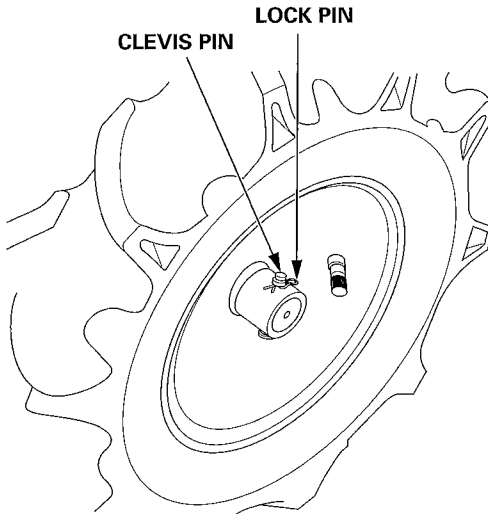

# SERVICING YOUR TILLER

## TINES AND FASTENERS CHECK

Be sure to check the tightness of fasteners at the following places:

- Tine cover and transmission case
- Tine cover and side cover
- Tine cover and rear shield
- Stiffening plate and tine hub

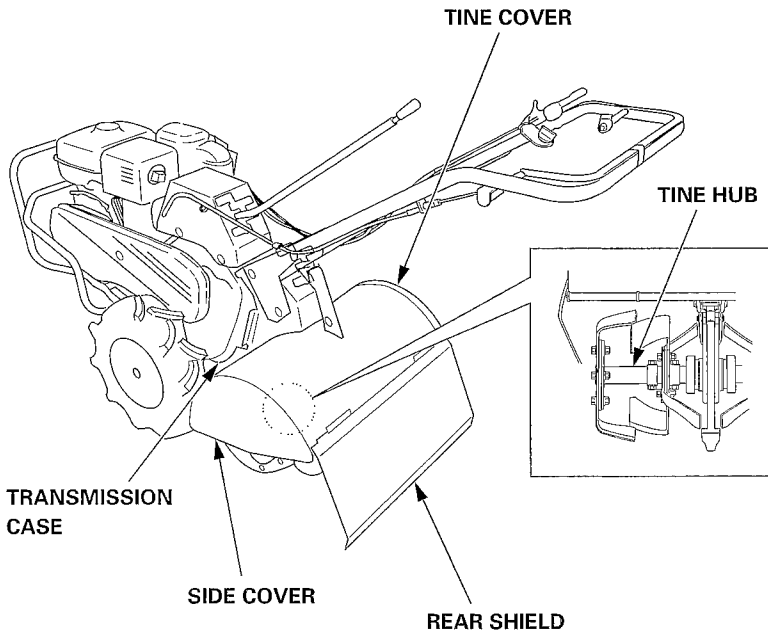

# STORAGE

## STORAGE PREPARATION

Proper storage preparation is essential for keeping your tiller trouble free and looking good. The following steps will help to keep rust and corrosion from impairing your tiller's function and appearance, and will make the engine easier to start when you use the tiller again.

### Cleaning

1. Wash the tiller, including the underside.

#### Engine

Wash the engine by hand, and be careful to prevent water from entering the air cleaner.

#### NOTICE

- *Using a garden hose or pressure washing equipment can force water into the air cleaner. Water in the air cleaner will soak the filter elements and can enter the carburetor or engine cylinder, causing damage.*
- *Water contacting a hot engine can cause damage. If the engine has been running, allow it to cool for at least half an hour before washing.*

#### Tiller

If using a garden hose or pressure washing equipment to clean the tiller, be careful to avoid getting water on the belts.

#### NOTICE

*Spraying water on hot tine shaft bearings can cause them to be damaged from cooling too quickly.*



2. After washing the tiller, wipe dry all accessible surfaces.
3. Start the engine outdoors, and let it run until it reaches normal operating temperature to evaporate any water remaining on the engine.
4. While the engine is running, operate the clutch lever to expel water from the pulleys, belts, and other moving items.
5. Stop the engine and allow it to cool.
6. After the tiller is clean and dry, touch up any damaged paint and coat other areas with a light film oil. Lubricate the throttle cable core with a silicone spray lubricant.

# STORAGE

---

## Fuel

Gasoline will oxidize and deteriorate in storage. Old gasoline will cause hard starting, and it leaves gum deposits that clog the fuel system. If the gasoline in your tiller deteriorates during storage, you may need to have the carburetor and other fuel system components serviced or replaced.

The length of time that gasoline can be left in your fuel tank and carburetor without causing functional problems will vary with such factors as gasoline blend, your storage temperatures, and whether the fuel tank is partially or completely filled. The air in a partially filled fuel tank promotes fuel deterioration. Very warm storage temperatures accelerate fuel deterioration. Fuel deterioration problems may occur within a few months, or even less if the gasoline was not fresh when you filled the fuel tank.

The Distributor's Limited Warranty does not cover fuel system damage or engine performance problems resulting from neglected storage preparation.

You can extend fuel storage life by adding a gasoline stabilizer that is formulated for that purpose, or you can avoid fuel deterioration problems by draining the fuel tank and carburetor.

### ***Adding a Gasoline Stabilizer to Extend Fuel Storage Life***

When adding a gasoline stabilizer, fill the fuel tank with fresh gasoline. If only partially filled, air in the tank will promote fuel deterioration during storage. If you keep a container of gasoline for refueling, be sure that it contains only fresh gasoline.

1. Add gasoline stabilizer following manufacturer's instructions.
2. After adding a gasoline stabilizer, run the engine outdoors for 10 minutes to be sure that treated gasoline has replaced the untreated gasoline in the carburetor.
3. Stop the engine, and turn the fuel valve to the off position.

## *Draining the Fuel Tank and Carburetor*

1. Place an approved gasoline container below the carburetor, and use a funnel to avoid spilling fuel.
2. Loosen the carburetor drain screw, then move the fuel valve to the ON position.

### **! WARNING**

Gasoline is highly flammable and explosive.

You can be burned or seriously injured.

Never use gasoline to clean engine parts. Use a nonflammable solvent.

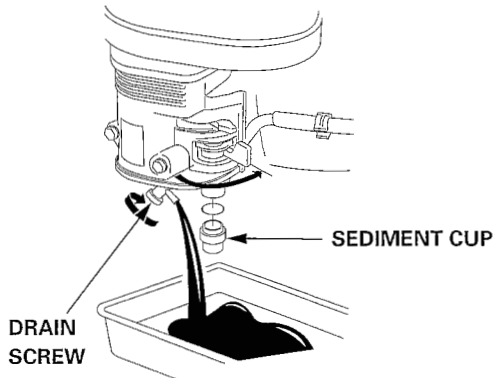

3. After all the fuel has drained into the container, tighten the drain screw securely.
4. Remove and empty the sediment cup, then reinstall the sediment cup and tighten securely.

# STORAGE

---

## Engine Oil

1. Change the engine oil (page 31).
2. Remove the spark plug (page 36).
3. Pour a tablespoon (5 - 10 cc) of clean engine oil into the cylinder.
4. Pull the starter rope several times to distribute the oil in the cylinder.
5. Reinstall the spark plug.
6. Pull the starter grip slowly until resistance is felt, and the notch on the starter pulley aligns with the hole at the top of the recoil starter cover.  
This will close the valves, so moisture cannot enter the engine cylinder. Return the starter rope gently.

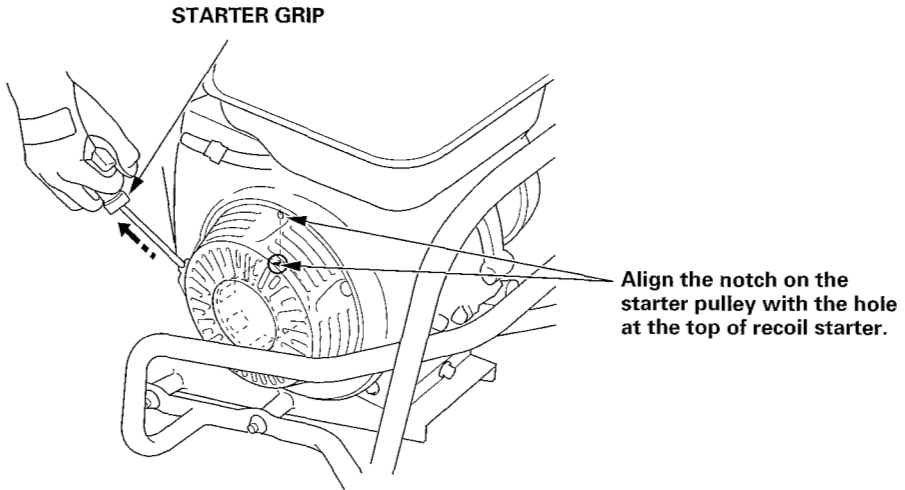

## STORAGE PRECAUTIONS

If your tiller will be stored with gasoline in the fuel tank and carburetor, it is important to reduce the hazard of gasoline vapor ignition. Select a well-ventilated storage area away from any appliance that operates with a flame, such as a furnace, water heater, or clothes dryer. Also avoid any area with a spark-producing electric motor, or where power tools are operated.

If possible, avoid storage areas with high humidity, because that promotes rust and corrosion.

Unless all fuel has been drained from the fuel tank, leave the fuel valve in the OFF position to reduce the possibility of fuel leakage.

Place the tiller on a level surface. Tilting can cause fuel or oil leakage.

With the engine and exhaust system cool, cover the tiller to keep out dust. A hot engine and exhaust system can ignite or melt some materials. Do not use sheet plastic as a dust cover. A nonporous cover will trap moisture around the tiller, promoting rust and corrosion.

## REMOVAL FROM STORAGE

Check your tiller as described in the *BEFORE OPERATION* chapter of this manual.

If the fuel was drained during storage preparation, fill the tank with fresh gasoline. If you keep a container of gasoline for refueling, be sure that it contains only fresh gasoline. Gasoline oxidizes and deteriorates over time, causing hard starting.

If the cylinder was coated with oil during storage preparation, the engine may smoke briefly at start-up. This is normal.

# **TRANSPORTING**

## **BEFORE LOADING**

If the engine has been running, allow it to cool for at least 15 minutes before loading the tiller on the transport vehicle. A hot engine and exhaust system can burn you and can ignite some materials.

Always turn the ignition switch to the OFF position. Make sure to turn the fuel valve OFF.

## **LOADING AND UNLOADING**

If a suitable loading ramp is not available, two people should lift the tiller on and off the transport vehicle while holding the tiller level.

Position the tiller so it sits flat on the bed of the transport vehicle. Tie the tiller down with rope or straps. Keep the tie-down rope or straps away from the controls, adjustment levers, cables, and the carburetor.

# TAKING CARE OF UNEXPECTED PROBLEMS

## ENGINE PROBLEMS

<b>Engine Will Not Start</b>	<b>Possible Cause</b>	<b>Correction</b>
1. Check control positions.	Fuel valve OFF.	Turn valve ON.
	Choke OPEN.	Move to CLOSED unless engine is warm.
	Engine switch OFF.	Turn engine switch to ON.
2. Check fuel.	Out of fuel.	Refuel (p.28).
	Bad fuel; tiller stored without treating or draining gasoline, or refueled with bad gasoline.	Drain fuel tank and carburetor (p.49). Refuel with fresh gasoline (p.28).
3. Remove and inspect spark plug.	Spark plug fault, fouled, or improperly gapped.	Clean, gap, or replace spark plug (p.36).
	Spark plug wet with fuel (flooded engine).	Dry and reinstall spark plug. Start engine with throttle lever in FAST position and the choke open.
4. Take tiller to an authorized Honda servicing dealer, or refer to the shop manual.	Fuel filter clogged, carburetor malfunction, ignition malfunction, valves stuck, etc.	Replace or repair faulty components as necessary.

## TAKING CARE OF UNEXPECTED PROBLEMS

---

<b>Engine Lacks Power</b>	<b>Possible Cause</b>	<b>Correction</b>
1. Check air filter.	Air filter clogged.	Clean or replace air filter (p.34).
2. Check fuel.	Bad fuel; tiller stored without treating or draining gasoline, or refueled with bad gasoline.	Drain fuel tank and carburetor (p.49). Refuel with fresh gasoline (p.28).
3. Take tiller to an authorized Honda servicing dealer, or refer to the shop manual.	Fuel filter clogged, carburetor malfunction, ignition malfunction, valves struck, etc.	Replace or repair faulty components as necessary.



# TAKING CARE OF UNEXPECTED PROBLEMS

---

## TILLING PROBLEMS

Poor Tilling Quality	Possible Cause	Correction
1. Check that the throttle lever is in the FAST position.	Engine speed is too slow to till well.	Move the throttle to the FAST position (p.11).
2. Reduce forward speed.	Tiller is moving too fast for soil conditions.	Shift to slower speed (p.20).
3. Check drag bar depth setting.	Drag bar adjustment set to high.	Lower drag bar adjustment (p.22).
4. Check tines	Tines dull, worn, or damaged.	Replace tines if necessary (p.43)
	Wrong tines installed.	Install correct tines (p.43).
	Tines installed incorrectly	Install tines correctly (p.43).

# TECHNICAL & CONSUMER INFORMATION

## TECHNICAL INFORMATION

### Serial Number Locations

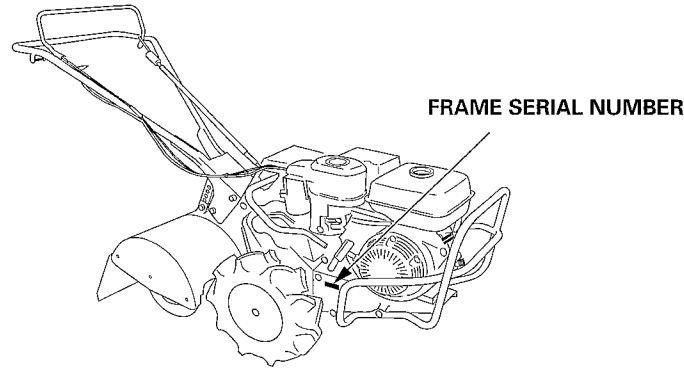
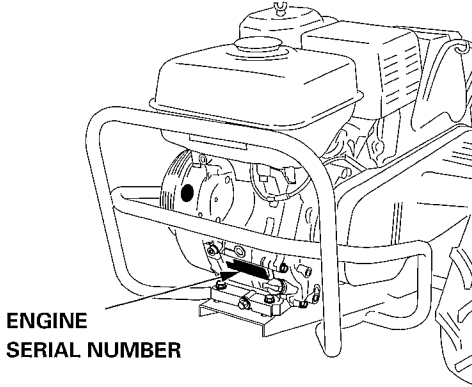

Record the engine and frame serial numbers in the spaces below. You will need this serial number when ordering parts, and when making technical or warranty inquiries.

Engine serial number: \_\_\_\_\_

Frame serial number: \_\_\_\_\_

## Carburetor Modification for High Altitude Operation

At high altitude, the standard carburetor air-fuel mixture will be too rich. Performance will decrease, and fuel consumption will increase. A very rich mixture will also foul the spark plug and cause hard starting. Operation at an altitude that differs from that at which this engine was certified, for extended periods of time, may increase emissions.

High altitude performance can be improved by specific modifications to the carburetor. If you always operate your tiller at altitudes above 5,000 feet (1,500 meters), have your servicing dealer perform this carburetor modification. This engine, when operated at high altitude with the carburetor modifications for high altitude use, will meet each emission standard throughout its useful life.

Even with carburetor modification, engine horsepower will decrease about 3.5% for each 1,000-foot (300-meter) increase in altitude. The effect of altitude on horsepower will be greater than this if no carburetor modification is made.

### **NOTICE**

*When the carburetor has been modified for high altitude operation, the air-fuel mixture will be too lean for low altitude use. Operation at altitudes below 5,000 feet (1,500 meters) with a modified carburetor may cause the engine to overheat and result in serious engine damage. For use at low altitudes, have your servicing dealer return the carburetor to original factory specifications.*

# TECHNICAL & CONSUMER INFORMATION

---

## Oxygenated Fuels

Some conventional gasolines are being blended with alcohol or an ether compound. These gasolines are collectively referred to as oxygenated fuels. To meet clean air standards, some areas of the United States and Canada use oxygenated fuels to help reduce emissions.

If you use an oxygenated fuel, be sure it is unleaded and meets the minimum octane rating requirement.

Before using an oxygenated fuel, try to confirm the fuel's contents. Some states/provinces require this information to be posted on the pump.

The following are the EPA approved percentages of oxygenates:

**ETHANOL** — (ethyl or grain alcohol) 10% by volume  
You may use gasoline containing up to 10% ethanol by volume. Gasoline containing ethanol may be marketed under the name "Gasohol".

**MTBE** — (Methyl Tertiary Butyl Ether) 15% by volume  
You may use gasoline containing up to 15% MTBE by volume.

**METHANOL**—(methyl or wood alcohol) 5% by volume  
You may use gasoline containing up to 5% methanol by volume, as long as it also contains cosolvents and corrosion inhibitors to protect the fuel system. Gasoline containing more than 5% methanol by volume may cause starting and/or performance problems. It may also damage metal, rubber, and plastic parts of your fuel system.

If you notice any undesirable operating symptoms, try another service station, or switch to another brand of gasoline.

Fuel system damage or performance problems resulting from the use of an oxygenated fuel containing more than the percentages of oxygenates mentioned above are not covered under warranty.

## **Emission Control System Information**

### ***Source of Emissions***

The combustion process produces carbon monoxide, oxides of nitrogen, and hydrocarbons. Control of hydrocarbons and oxides of nitrogen is very important because, under certain conditions, they react to form photochemical smog when subjected to sunlight. Carbon monoxide does not react in the same way, but it is toxic.

Honda uses lean carburetor settings and other systems to reduce the emissions of carbon monoxide, oxides of nitrogen, and hydrocarbons.

### ***The U.S. and California Clean Air Act***

EPA and California regulations require all manufacturers to furnish written instruction describing the operation and maintenance of emission control systems.

The following instructions and procedures must be followed in order to keep the Honda engine emissions within the emission standards.

### ***Tampering an Altering***

Tampering with or altering the emission control system may increase emissions beyond the legal limit. Among those acts that constitute tampering are:

- Removal or alteration of any part of intake, fuel, or exhaust system.
- Altering or defeating the governor linkage or speed-adjusting mechanism to cause the engine to operate outside its design parameters.

# TECHNICAL & CONSUMER INFORMATION

---

## ***Problems That May Affect Emissions***

If you are aware of any of the following symptoms, have your engine inspected and repaired by your authorized Honda servicing dealer.

- Hard starting or stalling after starting.
- Rough idle.
- Misfiring or backfiring under load.
- Afterburning (backfiring).
- Black exhaust smoke or high fuel consumption.

## **Replacement Parts**

The emission control systems on your new Honda engine were designed, built, and certified to conform with EPA and California emission regulations.

We recommend the use of genuine Honda parts whenever you have maintenance done. These original-design replacement parts are manufactured to the same standards as the original parts, so you can be confident of their performance. The use of replacement parts that are not of the original design and quality may impair the effectiveness of your emission control system.

A manufacturer of an aftermarket part assumes the responsibility that the part will not adversely affect emission performance. The manufacturer or rebuilder of the part must certify that use of the part will not result in a failure of the engine to comply with emission regulations.

## ***Maintenance***

Follow the Maintenance Schedule on page 27. Remember that this schedule is based on the assumption that your machine will be used for its designed purpose. Sustained high-load or high-temperature operation, or use in unusually wet or dusty conditions, will require more frequent service.

# TECHNICAL & CONSUMER INFORMATION

---

## Air Index

An Air Index Information hang tag/label is applied to engines certified to an emission durability time period in accordance with the requirements of the California Air Resources Board.

The bar graph is intended to provide you, our customer, the ability to compare the emissions performance of available engines. The lower the Air Index, the less pollution.

The durability description is intended to provide you with information relating to the engine's emission durability period. The descriptive term indicates the useful-life period for the engine's emission control system. See your *Emission Control Warranty* for additional information.

Descriptive Term	Applicable to Emissions Durability Period
Moderate	50 hours (0 - 65 cc) 125 hours (greater than 65 cc)
Intermediate	125 hours (0 - 65 cc) 250 hours (greater than 65 cc)
Extended	300 hours (0 - 65 cc) 500 hours (greater than 65 cc)

The Air Index Information hang tag must remain on the tiller until it is sold. Remove the hang tag before operating the tiller.

# TECHNICAL & CONSUMER INFORMATION

## Specifications

Model	FRC800
Description code	FAHJ
Dry weight	265 lbs (120 kg)
Length	65.4 in (1,660 mm)
Width	24.0 in (610 mm)
Height	48.8 in (1,240 mm)
Engine model	GX240K1
Type	4-stroke, Single cylinder, OHV, forced air cooled
Displacement	14.8 cu-in (242 cm <sup>3</sup> )
Bore × Stroke	2.9 × 2.3 in (73 × 58 mm)
Ignition system	Transistorized magneto
Spark plug	BPR6ES (NGK), W20EPR-U (DENSO)
Oil capacity	1.16 US qt (1.1 ℓ)
Fuel tank capacity	1.19 US gal (4.5 ℓ)
Clutch	Belt tension
Transmission oil capacity	5.3 US qt (5.0 ℓ)

Specifications may vary according to the types, and are subject to change without notice.

## Tune-up Specifications

ITEM	SPECIFICATION	MAINTENANCE
Spark plug gap	0.028 - 0.031 in (0.70 - 0.80 mm)	Refer to page: 36
Valve clearance	IN: 0.15 ± 0.02 mm (cold) EX: 0.20 ± 0.02 mm (cold)	See your authorized Honda dealer
Other specifications	No other adjustments needed	



# TECHNICAL & CONSUMER INFORMATION

---

## CONSUMER INFORMATION

### **Honda Publications**

These publications will give you additional information for maintaining and repairing your tiller. You may order them from your Honda tiller dealer.

#### ***Shop Manual***

This manual covers complete maintenance and overhaul procedures. It is intended to be used by a skilled technician.

#### ***Parts Catalog***

This manual provides complete, illustrated parts lists.

# TECHNICAL & CONSUMER INFORMATION

---

## Customer Service Information

Honda Power Equipment dealership personnel are trained professionals. They should be able to answer any question you may have. If you encounter a problem that your dealer does not solve to your satisfaction, please discuss it with the dealership's management. The Service Manager or General Manager can help. Almost all problems are solved in this way.

If you are dissatisfied with the decision made by the dealership's management, contact the Honda Power Equipment Customer Relations Office. You can write:

**American Honda Motor Co., Inc.**  
Power Equipment Division  
Customer Relations Office  
4900 Marconi Drive  
Alpharetta, Georgia 30005 - 8847

Or telephone: (770) 497-6400

When you write or call, please give us this information:

- Model and serial numbers (see page 56)
- Name of the dealer who sold the tiller to you
- Name and address of the dealer who services your tiller
- Date of purchase
- Your name, address, and telephone number
- A detailed description of the problem

# QUICK REFERENCE INFORMATION

Fuel	Type	Unleaded gasoline with a pump octane rating of 86 or higher (page 28)
	Capacity	1.19 US gal (4.5 ℓ)
Engine oil	Type	SAE 10W-30, API SJ, for general use (page 32)
	Capacity	1.16 US qt (1.1 ℓ)
Spark plug	Type	NGK: BPR6ES DENSO: W20EPR-U
	Gap	0.028 ~ 0.031 in (0.70 ~ 0.80 mm)
Carburetor	Idle speed	1,400 ± 150 rpm
Maintenance	Before each use	Check engine oil level. Check air filter. Tiller outside Each lever function Bolt and nut torque Cables and wires Engine operation Transmission oil
	First 20 hours	Change engine oil
	Subsequent	Refer to maintenance schedule (page 27)

# HONDA

The Power of Dreams

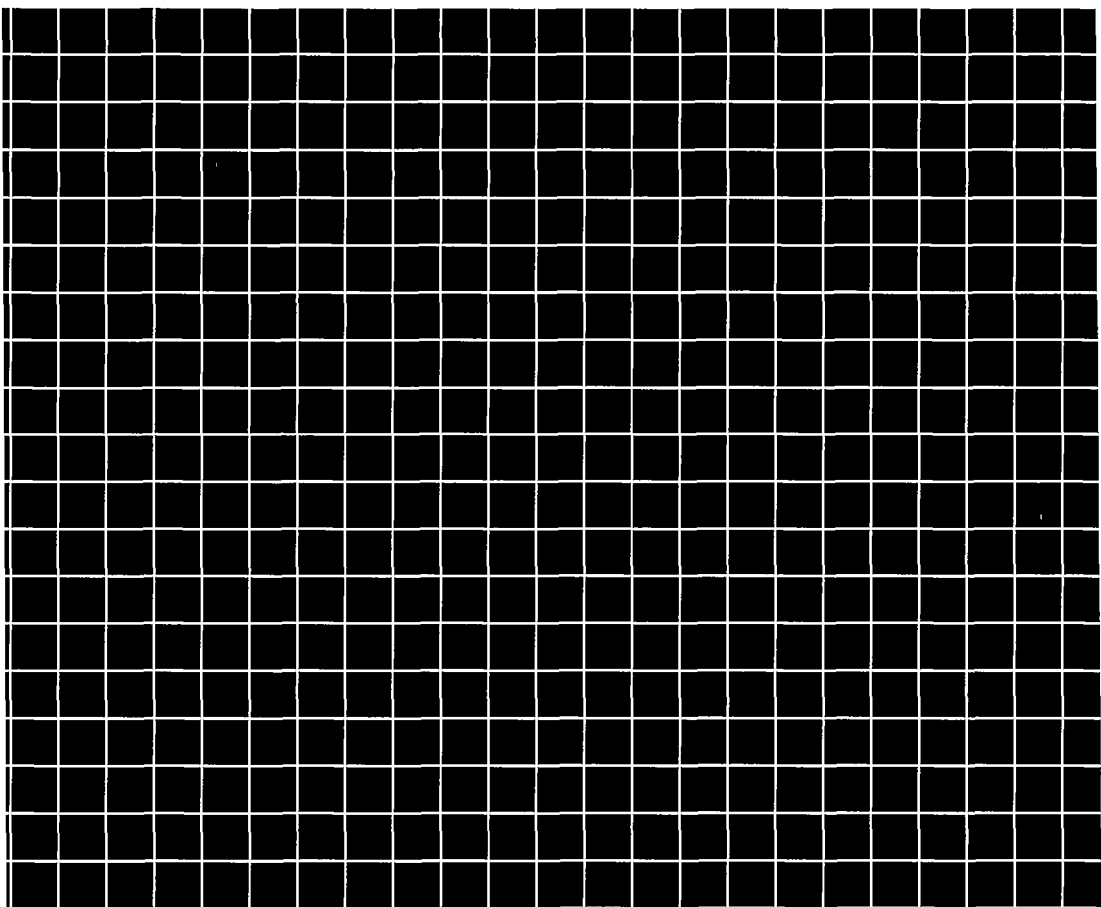

31V20600  
00X31-V20-6000

**EM3** (AH) (英) (Y) 2000.2002.07  
(Hi) Printed in Japan