Installation guide ***970 SmartRadar ATi***

March 2004
Part no. 4416.717_Rev.1



Enraf B.V.
P.O. Box 812
2600 AV Delft
Netherlands



Tel. : +31 15 2701100
Fax : +31 15 2701111
E-mail : info@enraf.nl
Website : <http://www.enraf.com>



Preface

The 970 SmartRadar ATi is a radar-based level gauge for liquid storage tanks.

This installation guide is intended for technicians involved in the mechanical and electrical installation of the Enraf series 970 SmartRadar ATi.

EC declaration of conformity

Refer to the EC declaration of conformity, shipped with the instrument.

Note:

All connections to the instrument must be made with shielded cables with exception of the mains, alarm output and Enraf field bus cable. The shielding must be grounded in the cable gland on both ends of the cable.

Note:

This device should only be used in a closed metal tank.

Legal aspects

The mechanical and electrical installation shall only be carried out by trained personnel with knowledge of the requirements for installation of explosion-proof equipment in hazardous areas.

The information in this installation guide is the copyright property of Enraf B.V., Netherlands. Enraf B.V. disclaims any responsibility for personal injury or damage to equipment caused by:

- Deviation from any of the prescribed procedures;
- Execution of activities that are not prescribed;
- Neglect of the general safety precautions for handling tools and use of electricity.

The contents, descriptions and specifications in this installation guide are subject to change without notice. Enraf B.V. accepts no responsibility for any errors that may appear in this installation guide.

Additional information

Please do not hesitate to contact Enraf or its representative if you require additional information.

For FCC compliant versions only

Warning

This device complies with Part 15 of the FCC Rules and with RSS-210 of Industry Canada. Operation is subject to the following two conditions:

- (1) this device may not cause harmful interference, and
- (2) this device must accept any interference received, including interference that may cause undesired operation.

Warning

The radiated output power of SmartRadar 970 LTi is far below the FCC radio frequency exposure limits. Nevertheless, the SmartRadar 970 LTi shall be used in such a manner that the potential for human contact during normal operation is minimized.

Warning

This equipment has been tested and found to comply with the limits for a Class B digital device, pursuant to Part 15 of the FCC Rules. These limits are designed to provide reasonable protection against harmful interference in a residential installation. This equipment generates, uses and can radiate radio frequency energy and, if not installed and used in accordance with the instructions, may cause harmful interference to radio communications. However, there is no guarantee that interference will not occur in a particular installation. If this equipment does cause harmful interference to radio or television reception, which can be determined by turning the equipment off and on, the user is encouraged to try to correct the interference by one or more of the following measures:

- Reorient or relocate the receiving antenna.
- Increase the separation between the equipment and receiver.
- Connect the equipment into an outlet on a circuit different from that to which the receiver is connected.
- Consult the dealer or an experienced radio/TV technician for help.

Warning

Changes or modifications made to this equipment not expressly approved by Enraf B.V. may void the FCC authorization to operate this equipment.

Safety

Safety aspects of 970 SmartRadar ATi

Warning

Do not use the instrument for anything else than its intended purpose.

The housing of the 970 SmartRadar ATi is explosion proof:

- II 1/2 G EEx de [ia/ib] II B T4; KEMA 03ATEX2468 X; certified by KEMA, Netherlands
- Class I, Division 1, Groups B, C, D T4, according to ANSI / NFPA 70 (Factory Mutual)

Environmental conditions for the SmartRadar ATi are:

ambient temperature : -40 to 60 °C (-40 to 140 °F)
operating pressure : max. 6 bar
relative humidity : 0 - 100 %
ingress protection : IP67

Warning

Improper installation of cable glands, conduits or stopping plugs will invalidate the Ex approval of the 970 SmartRadar ATi.

The emitted microwave energy is far below acceptable limits for exposure to the human body. Depending on the type of antenna, a maximum radiation of 0.1 mW/cm^2 is generated.

Personal safety

The technician must have basic technical skills to be able to safely install the equipment. When the 970 SmartRadar ATi is installed in a hazardous area, the technician must work in accordance with the (local) requirements for electrical equipment in hazardous areas.

Warning

In hazardous areas it is compulsory to use personal protection and safety gear such as: hard hat, fire-resistive overall, safety shoes, safety glasses and working gloves.

*Avoid possible generation of static electricity.
Use non-sparking tools and explosion-proof testers.*

Make sure no dangerous quantities of combustible gas mixtures are present in the working area.

Never start working before the work permit has been signed by all parties.

Pay attention to the kind of product in the tank. If any danger for health, wear a gas mask and take all necessary precautions.

Safety conventions

“**Warnings**”, “**Cautions**” and “**Notes**” are used throughout this installation guide to bring special matters to the immediate attention of the reader.

- A **Warning** concerns danger to the safety of the technician or user;
- A **Caution** draws the attention to an action which may damage the equipment;
- A **Note** points out a statement deserving more emphasis than the general text, but not requiring a “Warning” or a “Caution”.

Mechanical installation

Antenna and tank separator should already be installed (refer to installation guide SmartRadar antennas).

Install SmartRadar ATi housing on tank separator as follows:

- 1) Place housing on tank separator; mind locking pin!
- 2) Turn coupling nut manually securing the housing.

Electrical installation

The entire electrical installation shall be in accordance with the International Standard IEC 79-14 for electrical equipment to be installed in hazardous areas.

Warning

*Make sure that all power to the instrument is switched off before opening the covers of the 970 SmartRadar ATi. Failure to do so may cause danger to persons or damage the equipment.
All covers of the 970 SmartRadar ATi must be closed before switching on the power.*

Caution

Before opening the covers of the SmartRadar ATi, make sure that the blocking devices are removed (figure 1).

Use Allen key 3 mm.

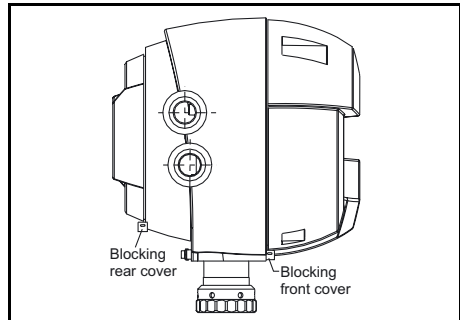

Figure 1 Blocking / sealing facilities

Caution

*Do not damage the thread of covers and 970 housing and keep the thread free of dirt.
After opening, grease it lightly with anti seize grease.*

*When closing, never tighten the covers before the threads are properly engaged.
The covers should be turned counter-clockwise until the thread "clicks" in place,
then turn clockwise until the covers are fully closed.*

After closing the covers, do not forget to place the blocking devices.

Preparing SmartRadar ATi for electrical installation

Mains supply, fuses and external mains switch

Mains supply for 970 SmartRadar ATi can be:

- 110 - 240 Vac 45/65 Hz, or
- 24 - 64 Vdc

Power rating : max. 25 VA (18 W).

Supply variations of +10% and -20% are allowed.

The 970 SmartRadar ATi is internally fused on the primary side. Refer to figure 2.

Fuse values, in accordance with IEC 127-2-3, are:

- 1.6 A slow; I^2t value $\geq 10 \text{ A}^2\text{s}$ for AC supply
- 2 A slow; I^2t value $\geq 25 \text{ A}^2\text{s}$ for DC supply

Install an explosion-proof mains switch in the mains supply cable to each 970 SmartRadar ATi. Specify which switch you need to operate the SmartRadar.



Figure 2 Fuses in 970 SmartRadar ATi

Grounding

The SmartRadar ATi housing should be properly grounded to the ground reference (generally the tank). This is a safety grounding requirement.

For this purpose, the SmartRadar ATi has an external ground terminal.

Caution

Safety depends on proper grounding. Check the resistance of the ground connection directly after installation. The measured ground resistance shall be below the maximum prescribed by local grounding requirements.

Warning

When measuring the ground resistance, use a suitable explosion-proof tester.

Note:

Grounding shall be performed in accordance with local regulations.

Cable glands / conduit

Cable glands:

Explosion proof (Ex-d) or increased safe (Ex-e) cable glands must be used, depending on local requirements. Refer to the Ex-marking on the identification label of the 970 SmartRadar ATi to determine which type of cable glands is required.

Note:

Mount the glands according to the supplier's instructions.

Conduit:

If the 970 SmartRadar ATi is installed in a hazardous area, threaded rigid metal conduit or threaded steel intermediate metal conduit shall be used.

Note:

*If the 970 SmartRadar ATi is installed in a hazardous area, stopper boxes **must** be applied within 18 inches (0.45 m) from the 970 SmartRadar ATi to seal the cabling in the conduit.*

Depending on the wiring configuration, one to three $\frac{3}{4}$ " NPT threaded cable glands (or rigid conduits) may be required with the 970 SmartRadar ATi.

Note:

Seal the unused cable inlets with an approved $\frac{3}{4}$ " NPT threaded stopping plug.

Warning

Improper installation of cable glands, conduit or stopping plugs will invalidate the Ex approval of your 970 SmartRadar ATi.

Lay-out terminal compartment

The terminal compartment at the rear of the 970 SmartRadar ATi is divided into a non-intrinsically safe and an intrinsically safe part. Cable entries are $\frac{3}{4}$ " NPT.

Intrinsically safe cabling may only enter at the left-hand side cable entry, marked Ex-i (figure 3).

Warning

Only open the terminal compartment cover (rear cover) when the power is switched off.

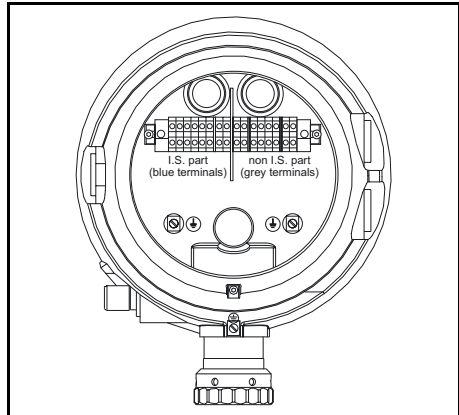

Figure 3 Terminal compartment

Non intrinsically safe connections

Mains

Mains cabling : Must be suitable for the 970 SmartRadar ATi power rating and, moreover, approved for use in hazardous areas.

Communication

Enraf field bus : One twisted pair cable is recommended. $R_{max} = 200 \Omega / \text{line}$; $C_{max} = 1 \mu\text{F}$. Maximum length: 10 km.

Enraf field bus lines may be interchanged. If local regulations allow, mains and Enraf field bus may share one cable. Mind the isolation voltage of the cores in the cable; refer to the International Standard IEC 61010-1.

Note:

If a quad cable is used and all four cores are twisted together, use two opposite cores for Enraf field bus lines and the two others for mains.

RS-232C (option): Cable: maximum length 15 m (50 ft); twisted pairs and shielded.

RS-485 (option): Cable: maximum length 1200 m (3900 ft); twisted pairs and shielded.

HART[®] / analog 4-20 mA (option) : Cable: twisted pair; shielded. Maximum cable length: 1500 m (5000 ft); $C_{max} = 40 \text{ nF}$; min. AWG 24 (0.2 mm²). Loop supply can be: external (passive) or internal (active).

Selecting external or internal loop supply is done by placing the connector with the brown wires for:

- external supply in: CN1 of ICU_HPO board (passive loop)
- internal supply in: CN2 of ICU_HPO board (active loop)

With active loop, the supply voltage in the loop is: 20 Vdc ($\pm 5\%$).

With passive loop, the minimum supply voltage is 8 Vdc; the maximum supply voltage is 64 Vdc. Supply voltages over 30 Vdc, require external series resistor (figure 4).

HART[®] communication requires a minimum series resistor of 250 Ω . Refer to figure 4, loop resistance graph. When HART[®] loop is external powered, minimum supply voltage is 14 Vdc and maximum supply voltage is 36 Vdc with 250 Ω resistor. With higher external supply voltage, series resistor must be increased. The maximum resistance for HART[®] communication is 1100 Ω , which corresponds to a maximum of 57 Vdc loop supply voltage.

The power rating of external resistor depends on resistance value; we recommend 1 W / k Ω .

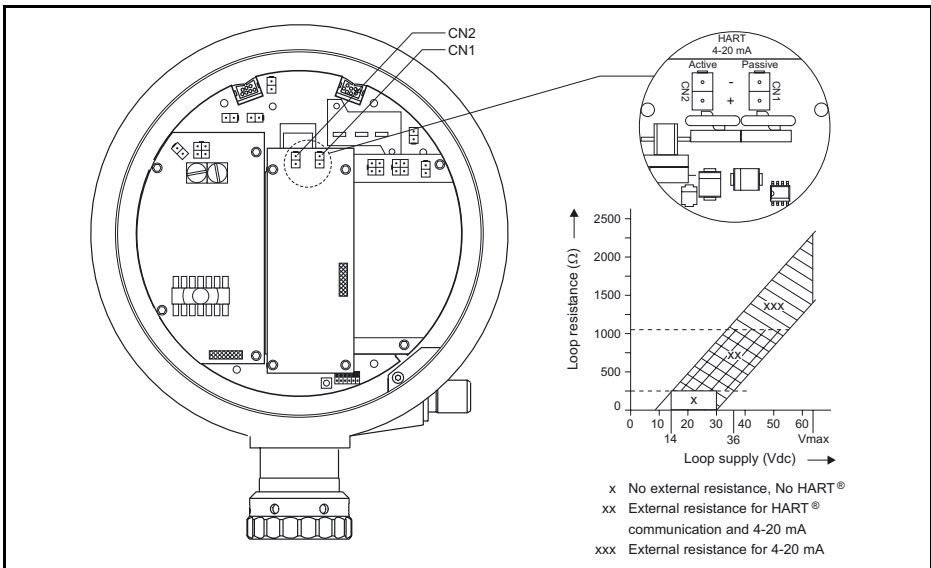

Figure 4 Changing passive/active loop supply and selecting external loop resistor

Hard alarm output contact

Relay output (option): Potential free relay contact; contact rating: $U_{max} = 50 \text{ Vac}$ or 75 Vdc ; $I_{max} = 3 \text{ A}$. Mind the isolation voltage of the cores in the cable; refer to the International Standard IEC 61010-1.

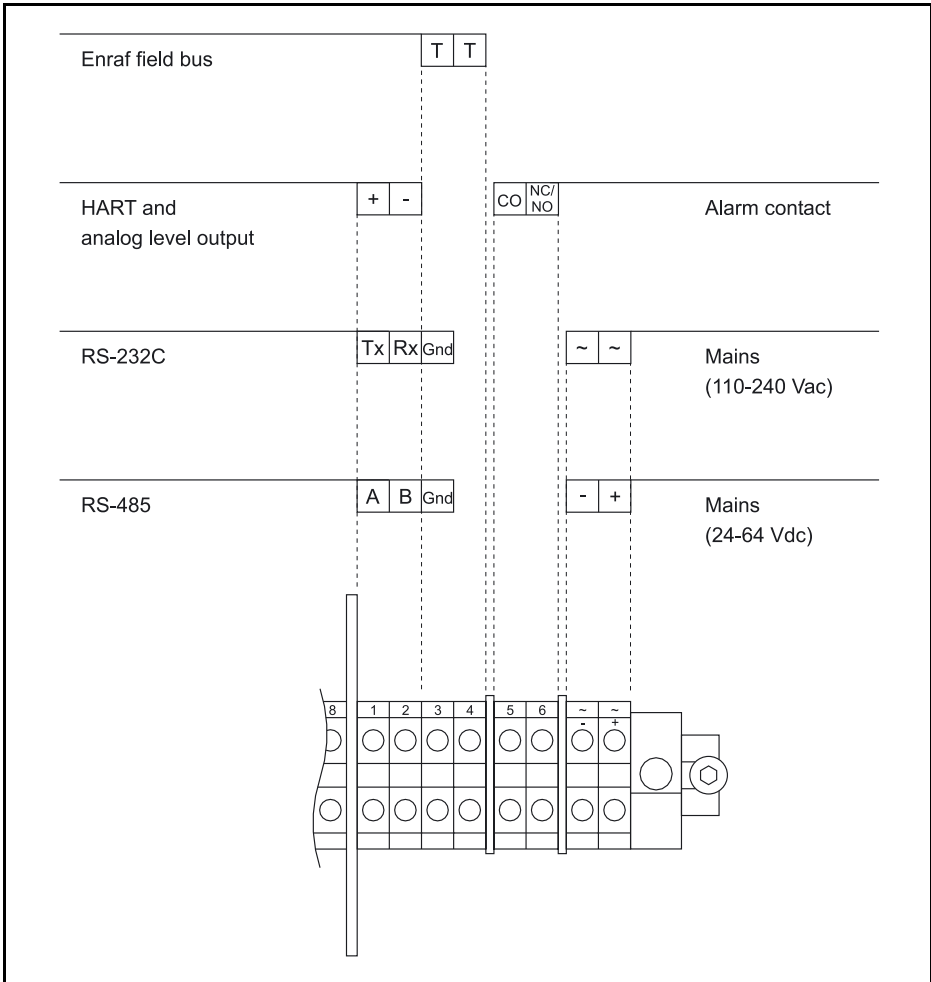

Figure 5 Non-intrinsically safe connections

Note:

Use either AC or DC supply (refer to instrument label).

When using RS-232C or RS-485 communication, Enraf field bus signal is **not** available.

When using HART[®] communication and/or analog level output, Enraf field bus signal is available.

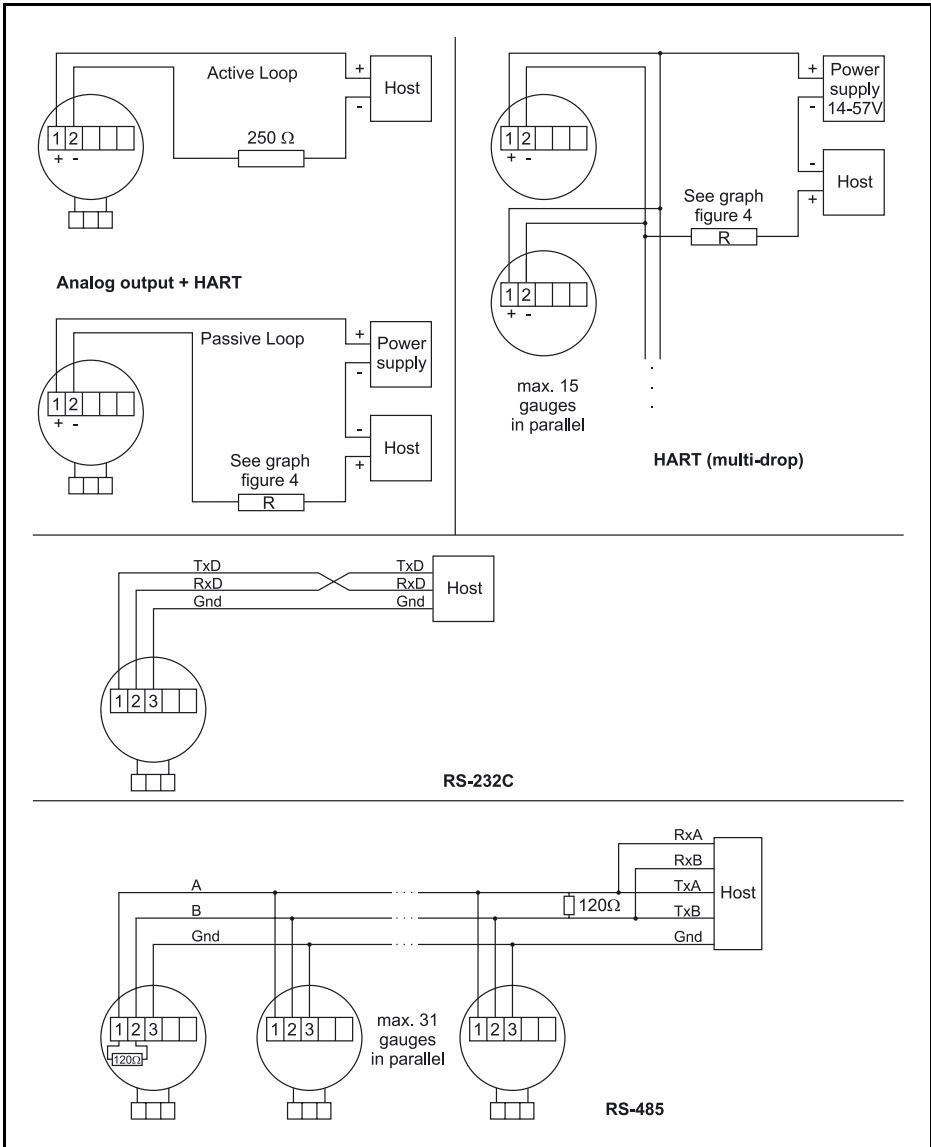

Figure 6 Detailed communication wiring

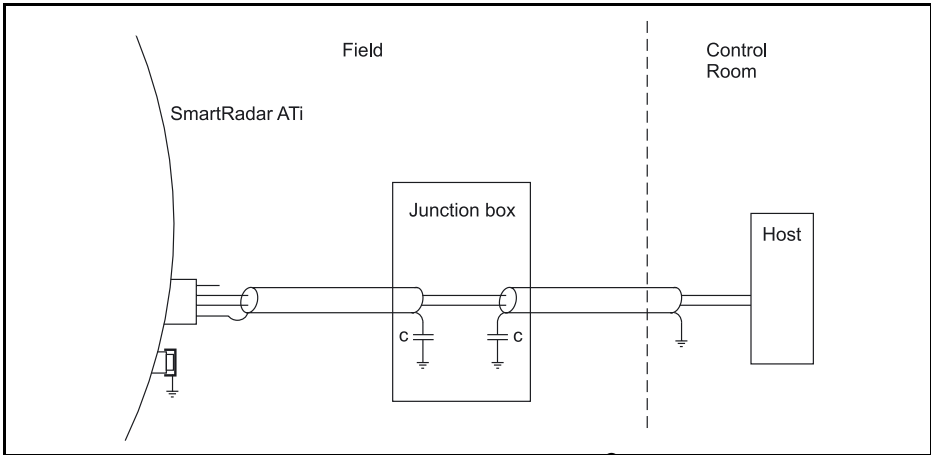

Figure 7 Grounding cable shield with RS-485 and HART[®] / analog output signal

The shielding of the RS-485 and HART[®] / analog output signals must be connected to ground at both sides of the cable. There can be a potential difference between tank ground and ground in the control room. Therefore, capacitors should be applied in the shield grounding between tank and control room, preferably in (one of) the junction box(es). Capacitance value: 10 to 100 nF. The capacitor can be located in a terminal. Such devices are available from for instance Phoenix.

At the end of a RS-485 transmission line a 120 Ω resistor must be placed (figure 6).

On the ICU_RS-232C/485 communication board the terminal resistance can be connected by means of jumper 1 (figure 8).

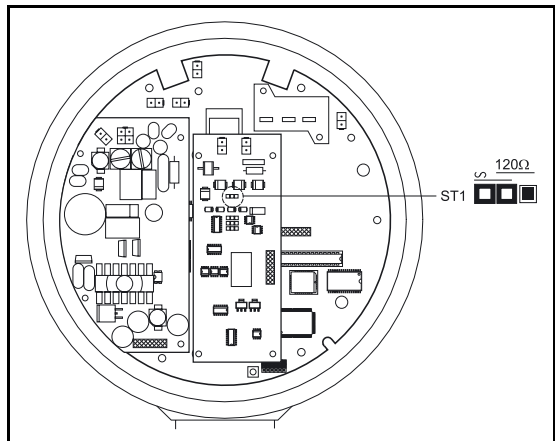

Figure 8 Selecting terminal resistor in RS-485 cabling

Intrinsically safe connections

The cable for the intrinsically safe option(s) should be fed through the cable entry at the side of the intrinsically safe (blue) terminals. Blue marked cables are recommended for the I.S. options. If more than one connection is to be made, an external junction box is required.

Caution

The intrinsically safe options described in this section have been certified as explosion-proof. Make sure that the certificate of approval is available on site and act in accordance with the instructions as given in the approval certificate.

Caution

Intrinsically safe wiring shall be separated from all other wiring. Cable lay-out shall be in accordance with local regulations.

Note:

*The shield of the intrinsically safe cable shall **not** be connected inside the SmartRadar ATi housing. Connect the shield of the cable externally in the cable gland at both ends of the cable.*

Device	Cable requirement
Spot temperature element	: Shielded; $R_{max} = 12 \Omega$ / line.
Average temp. element (combined water probe)	: Twisted pair and shielded; $R_{max} = 25 \Omega$ / line.
Pressure transmitters	: Twisted pair and shielded; $R_{max} = 25 \Omega$ / line (only pressure transmitters with HART [®] protocol). Pressure transmitter P1 is the bottom transmitter (measures liquid head) and P3 is the top transmitter (measures vapour pressure).
Water bottom probe (separate from temp. elem.)	: Twisted pair and shielded; $R_{max} = 25 \Omega$ / line (only with HART [®] protocol).
Tank Side Indicator	: Twisted pair and shielded; $R_{max} = 5 \Omega$ / line, maximum cable length 50 m (160 ft).

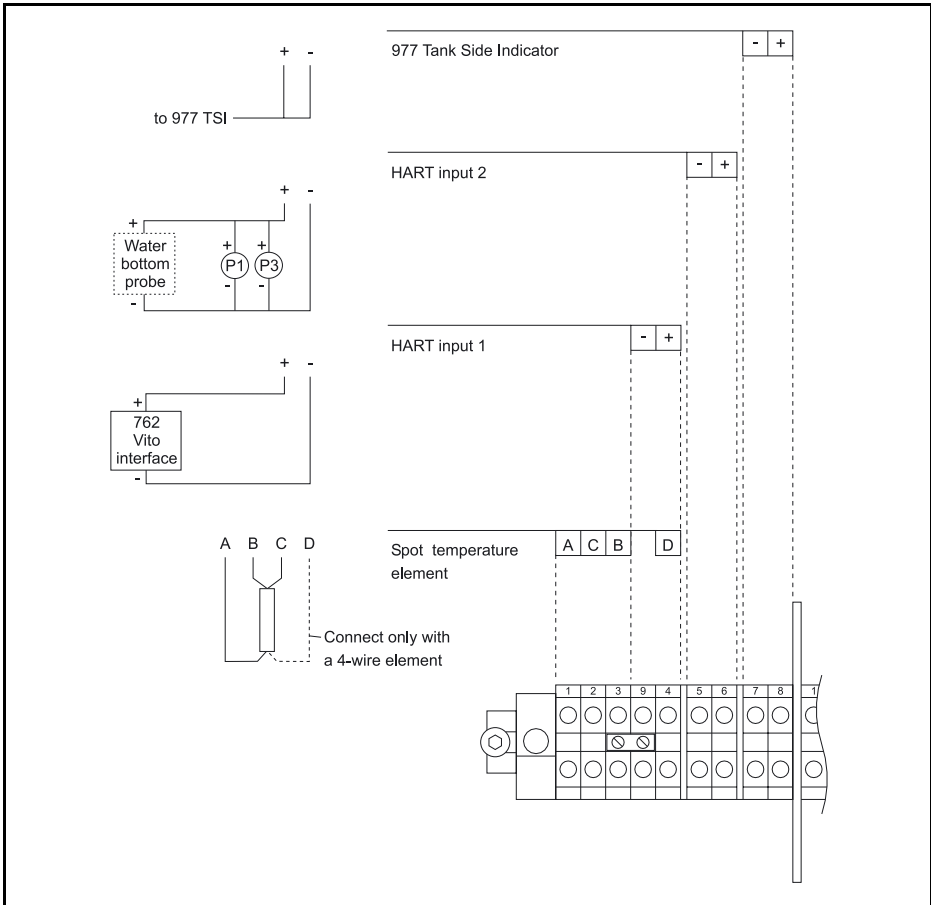
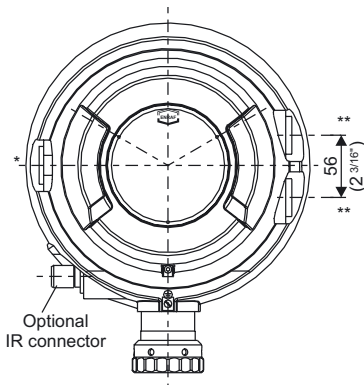
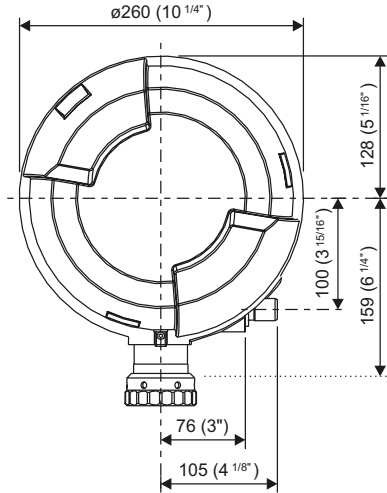
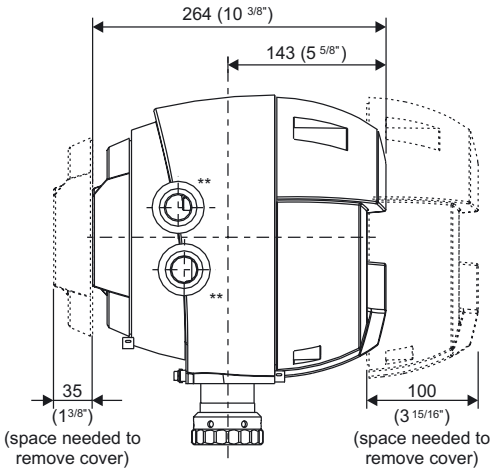

Figure 9 Intrinsically safe connections

Note:

If pressure transmitters are connected to HART input 2, it must be verified that the maximum values for current and power of the ICU_HPI option board HART input 2 circuit are not exceeding the maximum values of the connected pressure transmitters. Refer to Appendix B. If the values of the HART input 2 circuit are too high, then connect the pressure transmitters to HART input 1 and the 762 VITO Interface to HART input 2.

Appendix A Dimensional drawing



* Cable entry 3/4" NPT, Ex-i (1x)

** Cable entry 3/4" NPT (2x)

Appendix B ATEX Approval

The terminal compartment of the 970 SmartRadar ATi has been ATEX approved as explosion-proof and as being increased safe. The type of cable glands that must be used:

For protection type increased safe EEx e approved glands are to be used.

For protection type explosion-proof EEx d approved glands or conduits are to be used.

Connection requirements of optional boards

The identification label on the 970 SmartRadar ATi indicates whether your instrument is equipped with an optional board with intrinsically safe measuring circuits.

I.S. option for Tank Side Indicator, [EEx ib] IIB:

Output circuit for 977 TSI:

Max. values	:	U = 21 V, I = 325 mA, P = 1.5 W
Max. permissible ext. inductance	:	1.4 mH
Max. permissible ext. capacitance	:	1.27 μ F

ICU_HPI option board SPOT, [EEx ia] IIB:

Spot temperature input circuit:

Max. values	:	U = 23.1 V, I = 221 mA, P = 0.19 W
Max. permissible ext. inductance	:	3.5 mH
Max. permissible ext. capacitance	:	980 nF

ICU_HPI option board HART1, [EEx ia] IIB:

HART input 1 circuit (for 762 VITO interface):

Max. values	:	U = 23.1 V, I = 90 mA, P = 0.52 W
Max. permissible ext. inductance	:	15 mH
Max. permissible ext. capacitance	:	1.02 μ F

ICU_HPI option board HART2, [EEx ia] IIB:

HART input 2 circuit (for HART[®] pressure transmitters and/or external water probe):

Max. values	:	U = 23.1 V, I = 148 mA, P = 0.68 W
Max. permissible ext. inductance	:	7 mH
Max. permissible ext. capacitance	:	1.02 μ F

Appendix C Related publications

Model 970 SmartRadar ATi Safety instructions for installation, commissioning, operation and maintenance

Installation guide SmartRadar Antennas

Instruction manual 970 SmartRadar ATi

Installation guide VITO sensors

Installation instructions for MERCAP Side mounted water probe

Installation guide 977 TSI Tank Side Indicator

Installation info 003 (Installation HIMS system)



Delftechpark 39
2628 XJ, Delft

Tel. : +31 15 2701 100
E-mail : info@enraf.nl
Website : <http://www.enraf.com>

P.O. Box 812
2600 AV, Delft
Netherlands

We at Enraf are committed to excellence.

Your Enraf distributor

Information in this publication is subject to change without notice.
® Enraf is a registered trademark. © Enraf B.V. Netherlands.

