

DT8050A-SN

V-Plex® DUAL TEC® Motion Sensor with Anti-Mask - Installation Instructions

1 SELECT THE MOUNTING LOCATION

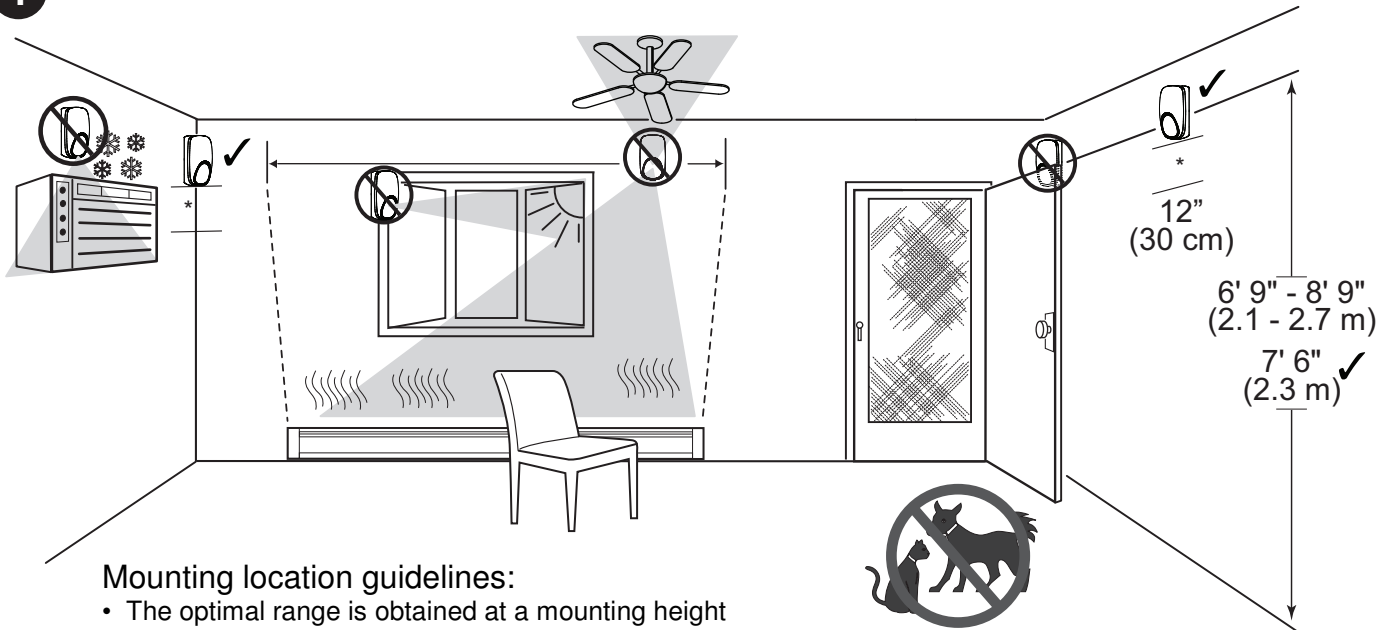

Mounting location guidelines:

- The optimal range is obtained at a mounting height of 7' 6" (2.3m).
- Allow a clear line-of-sight to all areas to protect.
- Avoid mounting anything within 12" (30cm) in front of the sensor*.
- Do not directly face windows.
- Avoid close proximity to moving machinery, fluorescent lights, and heating/cooling sources.
- Not for use in applications with pets.

2 OPEN THE SENSOR

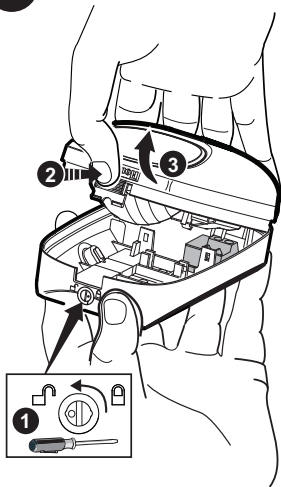

1. Turn the arrow to point to the Unlock symbol.
2. Press firmly on housing latch.
3. Gently separate the front and rear housing.

3 MOUNT THE SENSOR

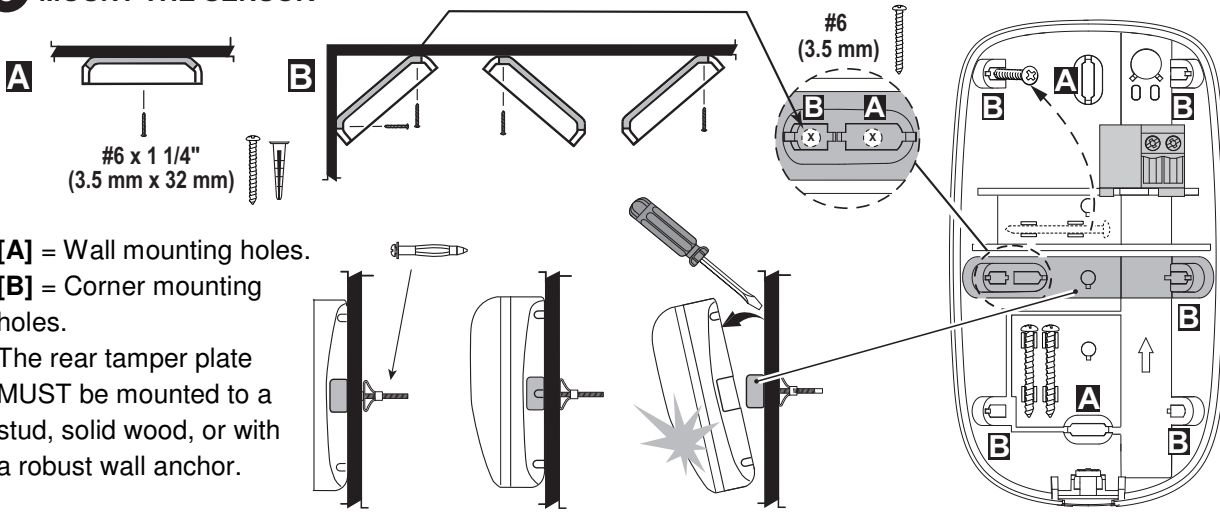

- [A] = Wall mounting holes.
- [B] = Corner mounting holes.
- The rear tamper plate MUST be mounted to a stud, solid wood, or with a robust wall anchor.

DT8050A-SN_step3-ii

4 SENSOR COMPONENTS AND SETTINGS

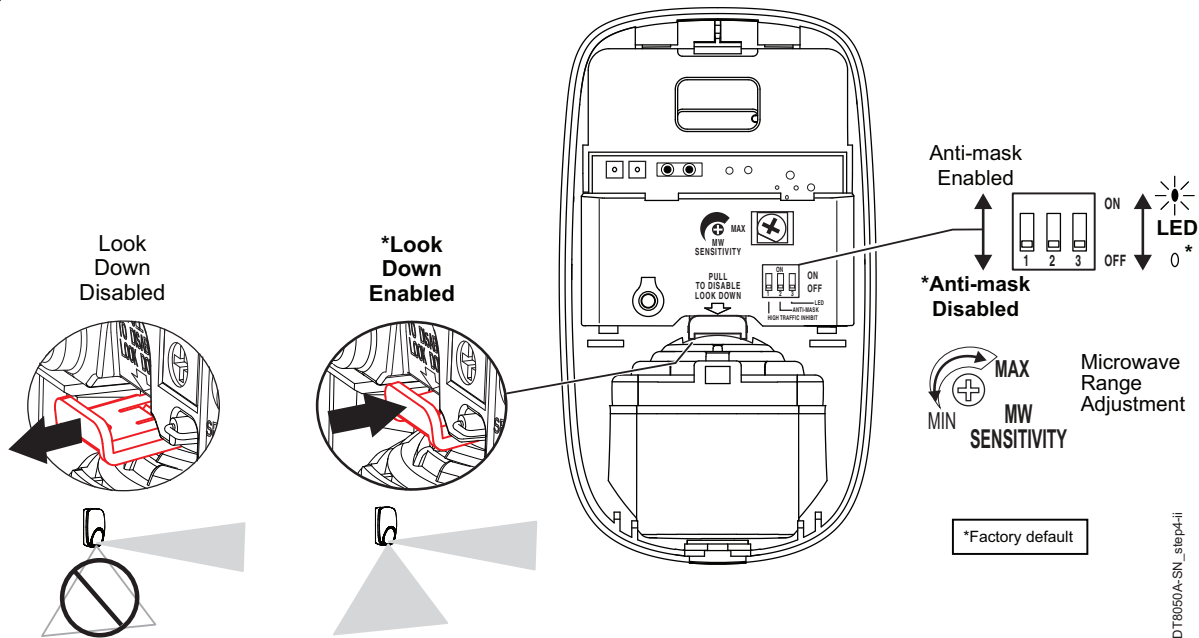

DT8050A-SN_step4-ii

5 WIRE THE SENSOR

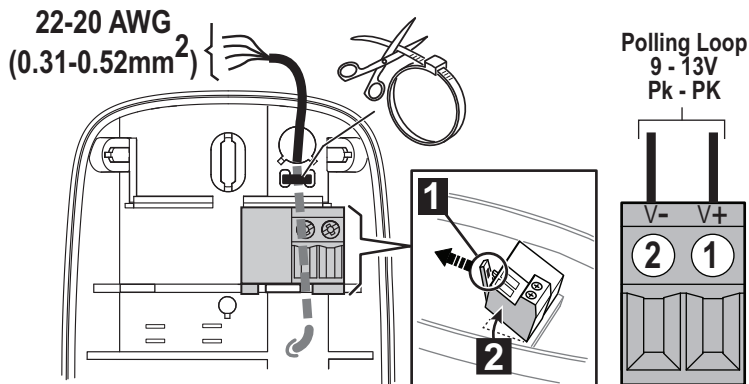

DT8050A-SN_step5-ii

6 WALK TEST THE SENSOR AND ADJUST AS NEEDED

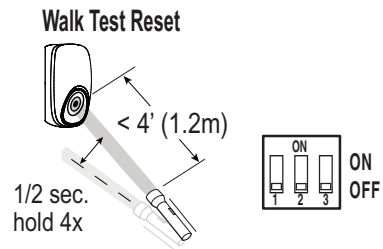
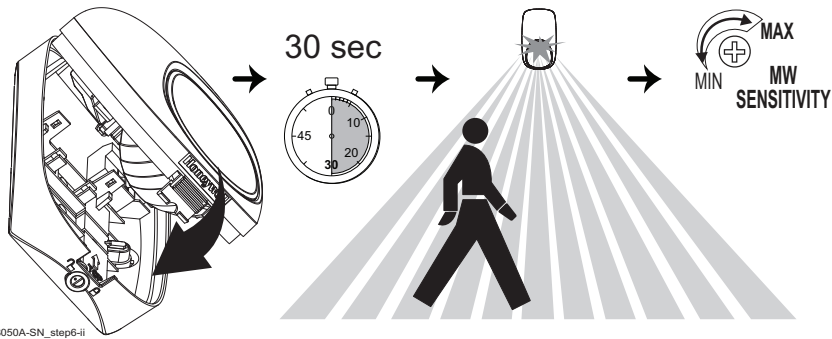

LED	Power Up	Walk Test	Normal	Trouble	Anti-Mask
Red	Slow Blink	ON Alarm	ON Alarm	Fast Blink	OFF
Yellow	OFF	ON Microwave	ON Microwave	OFF	Fast Blink
Green	OFF	ON PIR	ON PIR	OFF	OFF

1. Apply power to the sensor. Initialization is complete when the LED stops flashing slowly (about 30 seconds).
2. Turn the microwave sensitivity counterclockwise to reduce the microwave range (minimum = 16.4' / 5m) and close the sensor.
3. Walk through the detection area and observe the LED.
4. Adjust the microwave range as necessary to meet installation requirements.

Walk test mode is active for 10 minutes, then automatically exits test mode, disables the LED and enters normal operation mode. For an additional 10 minute walk test, enable walk test mode again with the flashlight feature:

Note: During power up and walk test modes the LED is active regardless of the LED Enable/Disable DIP switch setting.

Flashlight Feature:

1. Use a flashlight with a bright light beam, and stand within 4' (1.2 m) of the sensor.
2. Swing the light beam past the sensor IR window 3-5 times, holding the beam on the window for 0.5 second each pass.

The flashlight feature is only available for the first 24 hours after power up.

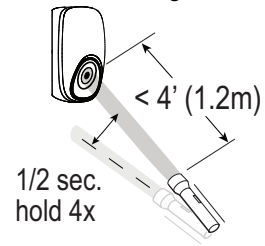

7 DETECTION PATTERNS

Top View

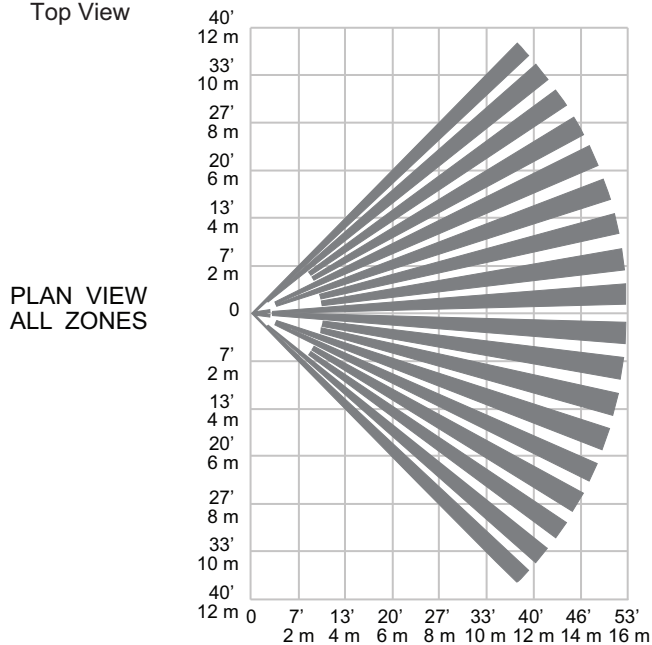

Side View

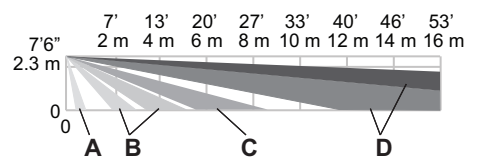

Zones

A	2 Look-down
B	12 Lower
C	10 Intermediate
D	36 Long

PROGRAM THE SENSOR

This sensor is a serial number device. Refer to the control panel's manual for instructions on registering devices and programming.

For all V-Plex® panels, program the sensor Zone Type as **INT FOLLOWER 04** and the INPUT TYPE as **"06"** (for SL - Serial Polling Device).

If using a Smart V-Plex® panel, program the sensor to Standard mode [press **"0"** (No)] or SMART CONTACT mode [press **"1"** (Yes)].

Standard Mode: The sensor includes a selectable High Traffic Inhibit (HTI) feature. This feature reduces bus traffic with a randomized delay (from 5 – 15 seconds) between alarm signals after an alarm and restoral signal is sent. In applications where this delay is not necessary, set DIP Switch 1 to OFF.

IMPORTANT: If using the Anti-Mask feature, the sensor **MUST** be programmed to Standard Mode.

Smart Contact Mode: In the Smart Contact mode, the sensor automatically reduces bus traffic by not sending alarm signals when disarmed.

ALL modes: Tamper, self-test failures and anti-mask¹ signals are sent without delays.

¹Anti-mask signals are only sent when Anti-mask is enabled (DIP switch 2 ON), except during Microwave Walk Test mode. See step 6.

LED OPERATION

The LED can be enabled in several ways:

- After power up mode the LED is enabled for 10 minutes (DIP switch 3 ON or OFF).
- Remove and replace the front cover to enable the LED for 10 minutes (DIP switch 3 ON or OFF).
- Set DIP switch 3 ON (LED Enable); LED remains enabled until disabled (switch 3 OFF). [Exception: When programmed to Smart Contact mode and the system is armed, the LED is always disabled.]
- Remote LED Enable. [If using a Smart V-Plex® panel, a Remote LED Enable feature may be available, which allows remote enabling of the LED if DIP switch 3 is OFF. (Refer to the Burglary Walk-Test section in the control panel's manual.) Using this method, the LED remains enabled while the panel is in the burglary walk test mode.]

MASK CONDITION

Normal Anti-Mask Condition

The sensor uses Active Infrared (AIR) technology to detect masking. The sensor signals a mask condition when a variety of materials and reflective objects are placed within 2 inches (50mm) in front of the sensor. To avoid false mask alarms, follow the mounting guidelines shown in Step 1.

Clearing an Anti-Mask Condition

When most masking materials or objects are removed, the anti-mask condition will be cleared after several seconds. When the cause of the anti-mask condition is any type of spray or paint coating applied to the window, the window must be replaced before the anti-mask condition can be cleared. After replacing the window, perform a walk test on the sensor.

TROUBLESHOOTING

	NORMAL	TROUBLE*	
		Mask ¹	Self-Test Failure ²
Red LED	Off	Off	Flashing
Yellow LED	Off	Flashing	Off

*TROUBLE CONDITIONS:

¹ Mask condition: Sensor IR window is blocked or masked.

² Self-Test Failure conditions:

- Microwave supervision failure: The sensor is operating in PIR mode only.
- PIR self-test failure: The sensor is disabled.
- Temperature compensation failure: The temperature compensation is disabled.

Depending on the Trouble condition, take the following corrective actions:

- Verify the sensor is not blocked or masked.
- Cycle power to the sensor.
- Walk test the sensor.

If the Trouble condition does not clear, replace the sensor.

SPECIFICATIONS

Range: 53' x 72' / 16 m x 22 m

Wall Mounting Height: 6'9" - 8'9" (2.1 m - 2.7 m); Optimal 7'6" (2.3 m)

Power: 9.0-13V PK – PK at polling loop terminals; (UL: 9.5-15VDC); 4 mA maximum.

Tampers: Cover & Wall

Microwave Frequencies: 10.525 GHz

RFI Immunity: 20V/m 10-1000MHz, 15V/m 1000-2700MHz

PIR White Light Immunity: 6,500 Lux typical

Fluorescent light filter: 50 Hz / 60 Hz.

Operating Temperature: 14° to 131° F / -10° to 55° C

Relative Humidity: 5 to 93% (UL tested at 93%); non-condensing

Temperature Compensation: Advanced Dual Slope

Dimensions: 4.57" H x 2.76" W x 1.69" D /

11.6 cm H x 7.0 cm W x 4.3 cm D

Weight: 5 oz / 142 g (net weight)

ACCESSORIES

SMB-10* (P/N 0-000-110-01)	Swivel Mount Bracket
SMB-10C* (P/N 0-000-111-01)	Swivel Mount Ceiling Bracket
SMB-10T* (P/N 0-000-155-01)	Swivel Mount Bracket w/Tamper
Cable* (P/N 1103)	General purpose, Solid 22 AWG, 4 conductor
Cable* (P/N 1104)	General purpose, Stranded 22 AWG, 4 conductor
Cable* (P/N 1106)	General purpose, Solid 22 AWG, 6 conductor
Cable* (P/N 1107)	General purpose, Stranded 22 AWG, 6 conductor

* Not evaluated by UL.

APPROVAL LISTINGS

- FCC part 15, Class B verified
- IC ICES-003, Class B verified
- UL 639
- ULC S306-03
- SIA-PIR-01 Passive Infrared detector standard features for false alarm immunity.

Product must be tested at least once each year.

All wiring must be in accordance with: the National Electrical Code (ANSI/NFPA70); the Canadian Electrical Code, Part I (where applicable); UL681, Standard for Installation and Classification of Burglar and Holdup Alarm Systems; ULC-S302, Standard for Installation and Classification of Burglar Alarm Systems for Financial and Commercial Premises, Safes and Vaults; ULC-S310, Standard for Installation and Classification of Residential Burglar Alarm Systems; local codes and the authorities having jurisdiction.

The products are intended to be powered by a power-limited output of a UL/CUL Listed Burglar Alarm control unit, or via a Listed UL603/ULC-S318 power-limited power supply that provides 4 hours of standby power.

The sensor must be mounted indoors, within the protected premises, and on a wooden stud, solid wood or with a robust wall anchor.

UL Notes: All interconnecting devices must be UL Listed. The anti-mask feature has not been evaluated by UL.

FCC Notes: This transmitter must not be co-located or operating in conjunction with any other antenna or transmitter.

FEDERAL COMMUNICATIONS COMMISSION STATEMENTS

The user shall not make any changes or modifications to the equipment unless authorized by the Installation Instructions or User's Manual. Unauthorized changes or modifications could void the user's authority to operate the equipment.

CLASS B DIGITAL DEVICE STATEMENT

This equipment has been tested to FCC requirements and has been found acceptable for use. The FCC requires the following statement for your information:

This equipment generates and uses radio frequency energy and if not installed and used properly, that is, in strict accordance with the manufacturer's instructions, may cause interference to radio and television reception. It has been type tested and found to comply with the limits for a Class B computing device in accordance with the specifications in Part 15 of FCC Rules, which are designed to provide reasonable protection against such interference in a residential installation. However, there is no guarantee that interference will not occur in a particular installation. If this equipment does cause interference to radio or television reception, which can be determined by turning the equipment off and on, the user is encouraged to try to correct the interference by one or more of the following measures:

- Reorient the receiving antenna until interference is reduced or eliminated.
- Move the radio or television receiver away from the receiver/control.
- Move the antenna leads away from any wire runs to the receiver/control.
- Plug the receiver/control into a different outlet so that it and the radio or television receiver are on different branch circuits.
- Consult the dealer or an experienced radio/TV technician for help.

INDUSTRY CANADA CLASS B STATEMENT

This Class B digital apparatus complies with Canadian ICES-003.
Cet appareil numérique de la classe B est conforme à la norme NMB-003 du Canada.

FCC / IC STATEMENT

This device complies with Part 15 of the FCC Rules, and Industry Canada's license-exempt RSSs. Operation is subject to the following two conditions: (1) This device may not cause harmful interference, and (2) This device must accept any interference received, including interference that may cause undesired operation.

Cet appareil est conforme à la partie 15 des règles de la FCC et exempt de licence RSS d'Industrie Canada. Son fonctionnement est soumis aux conditions suivantes: (1) Cet appareil ne doit pas causer d'interférences nuisibles. (2) Cet appareil doit accepter toute interférence reçue y compris les interférences causant une réception indésirable.

REFER TO THE INSTALLATION INSTRUCTIONS FOR THE CONTROL WITH WHICH THIS DEVICE IS USED FOR DETAILS REGARDING LIMITATIONS OF THE ENTIRE ALARM SYSTEM.

For patent information, see www.honeywell.com/patents

For the latest documentation and online support information, please go to:
<http://www.security.honeywell.com/hsc/resources/MyWebTech/>

For the latest U.S. warranty information, please go to: www.honeywell.com/security/hsc/resources/wa or
Please contact your local authorized Honeywell representative for product warranty information.

