

## EVORA Series Datasheet

### Overview

The EVORA family of switches offers an elegantly designed, easy to use, feature-rich user interface and control system providing a state-of-the-art guestroom automation experience. EVORA allows guest control of multiple lighting loads, temperature, drapes, and guest annunciation from multiple switch locations in the guestroom. EVORA offers three different user interface modules and multiple different Load Assemblies that include wired and wireless communications, dimmers, and programmable controls designed to operate within INNCOM's Integrated Room Automation System (IRAS). The EVORA system brings all guestroom control features into a sleekly designed traditional keypad user interface.



**Figure 1 EVORA Switch**

### Features

- Up to 7 key configurations with up to 5 position key pad for programmable control of any IRAS feature
- Nightlight configuration with 2 key positions
- Doorbell configuration with 2 key positions
- Optional multifunction key for up to 10 grouped features per device
- Backlight illuminated keys and text
- TRIAC dimmer
- FET dimmer
- Relay actuator
- Master contactor application
- 12VDC power supply
- Low-voltage adapter for load center applications
- 2.4Ghz 802.15.4 wireless RF network communications
- S5bus wired network communications
- Digital input for door switch contact / integration with the INNCOM energy management system (EMS)
- Software programmable for any CBL feature

### Application

EVORA was developed to extend INNCOM switch capabilities beyond those offered in the well-established S-Series (S217 and S5XX) product families and the innovative MODEVA series. The EVORA series uses a modular, cross functional hardware platform that allows each of the three main products (multifunctional switch, nightlight, and doorbell ) to share features in both hardware and software that were previously available only as uniquely designed sub-assemblies in the legacy S-Series products.

EVORA has at its core the same Load Assembly (WBI) architecture used by INNCOM's MODEVA line. The Load Assembly is available in six configurations—500W relay, 500W TRIAC dimmer, 350W FET dimmer, 30A master contactor, 200mA power supply, and a low-voltage adapter (LVA)—that provide the mechanical platform and load bearing capability for the EVORA system. The EVORA series differs from MODEVA in several ways. It uses a

standard dimension mounting bracket, for instance, allowing EVORAs to be ganged with other products (similar to the S-Series). EVORA products come factory assembled.

## Categories of Load Assembly Load Switching

- TRIAC dimmer provides dimming control of resistive light loads such as incandescent, halogen, and TRIAC dimmable LEDs. The TRIAC dimmer can dim 100–120VAC loads up to 500W.
- FET dimmer dims capacitive loads such as dimmable fluorescent lamps and electronic ballasts. It can also dim resistive loads such as incandescent, halogen, and dimmable LEDs. The FET dimmer is designed to dim 100–120VAC up to 350W.
- Relay power supply switches capacitive, inductive, resistive, and general purpose loads up to 500W.
- Master contactor controls 30A relay at 120–240VAC.
- 200mA power supply used for applications where EVORA must be line powered but does not require load dimming or switching.
- Low-voltage adapter allows the EVORA products to run in a +12VDC powered device that does not actuate a load. This is very similar to the legacy S5XX product.

## Load Assembly Parallel Power Supplies

The WBI actuators operate in parallel to supply a higher load capacity on the +12VDC rail than that achievable by a single actuator. The total output power of the actuators in parallel is based on the voltage specifications at maximum load versus the output current at maximum load and nominal recovery time after a foldback condition occurs. This design can aggregate up to 6 actuators into a system that permits up to a combined 990mA (~1A) +12VDC output. See **Class 2 Output** table below.

## Additional Load Assembly Technical Features

- Air-gap relay required (for dimmers meeting UL 508). Where solid state dimmers are used, disengages the load from the line power in the event that a failed actuator causes a short or a closed circuit (as with a FET dimmer), a possible electric shock risk during routine maintenance or lamp replacement.
- Additional overload detection circuit for FET dimmer that senses a catastrophic overload / short and shuts down the dimmer to protect the solid state circuitry.
- Dimming linearization curve may be set by application engineer to calibrate the duty cycle of a Pulse Width Modulated signal driving the various lamp types that could be used.
- Self contained actuator that can be used without the user interface. This is useful during installation (with EVORA) and in repair to isolate symptoms related specifically to the actuator.

## Load Assembly Installation

 Locate the fuse panel and remove fuses or ensure the breaker is in the OFF position before installing the Load Assembly.

1. Pull the class-2 wires for Ground (Brown), +12VDC (Red) and S5bus (Orange) and digital inputs into the wall box (See Wiring Diagrams). Make the connections using a dolphin DC-1000P Super B connector or equivalent type connector to the S5bus or digital input harnesses and connect them to the appropriate header on the Load Assembly.
2. Prepare the line voltage wiring by stripping back the insulation 16mm (5/8th inch).
3. Connect the Green (Earth) Cable attached to the Load Assembly Strap to Earth.

4. Wire the Load Assembly as described in the Wiring Diagrams. Depending on gang assembly using the appropriate 10, 12, 14, 16, or 18 AWG wire nut.
5. Push all wires back into the wall box and fasten the control to the wall box using the supplied mounting screws. Be sure not to pinch or disconnect any of the wires.
6. Ensure the intended load(s) are connected to the circuit.
7. Replace the fuses in the fuse panel or move the breaker to ON before continuing.

**Note: EVORA self test may require that an I/O map is configured. The following steps are general guidance only. Installers should refer to the property-specific install and commissioning documents for further guidance.**

8. Allow the EVORA switch to power up. To verify power, observe whether indicator light or backlight illuminate or blink.
9. Testing EVORA depends on the specific software configuration.
10. The EVORA User Interface will display start up behavior (refer to the property-specific installation and commissioning guide(s) and then enter a self test mode for the first 20 seconds of operation.

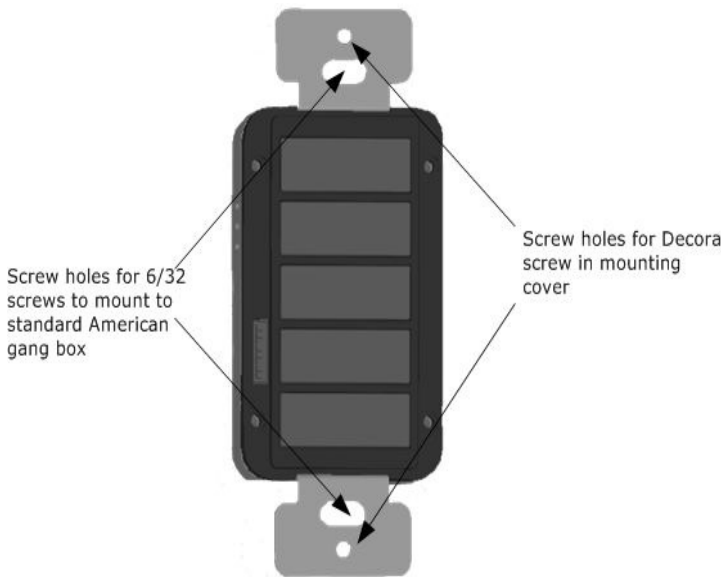

**Figure 2 Mounting Screw Holes**

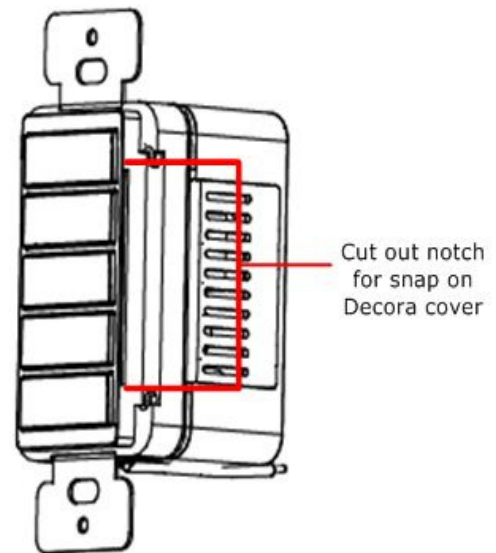

**Figure 3 Decora Notch**

The EVORA and Load Assembly is supplied with two 1¼" 6/32 screws, two 3-pin S5bus harnesses and a two-pin pig-tail harness for the digital input.

### Wiring Diagrams

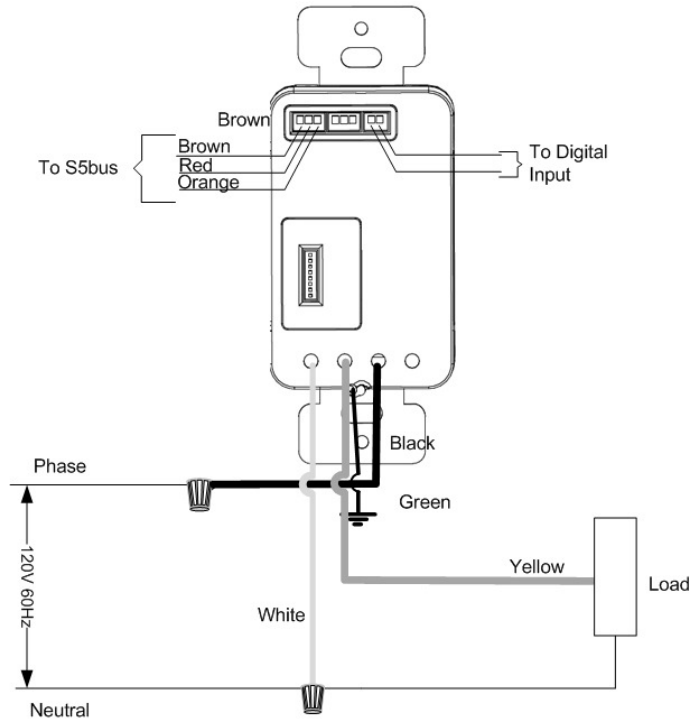

Figure 4 EVORA WBI Single Wiring

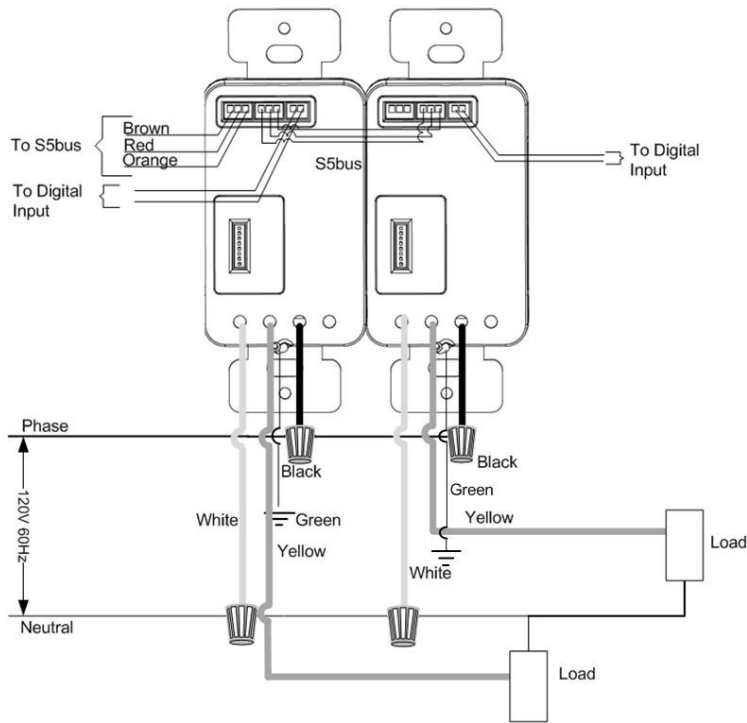
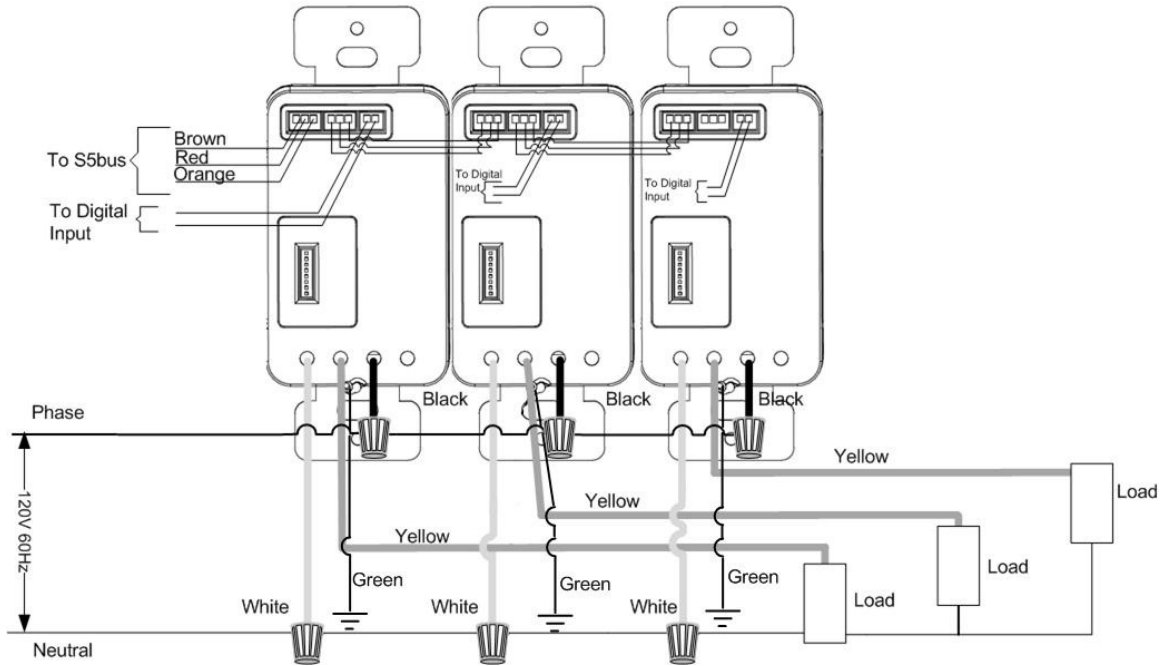

Figure 5 EVORA WBI Double Wiring

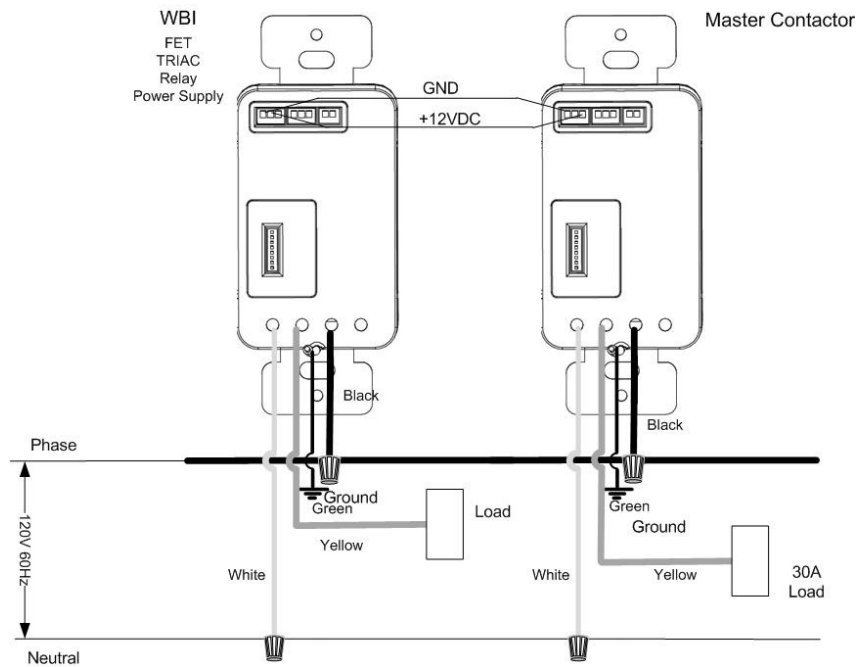

**Figure 6 EVORA WBI Triple Wiring**

In double and triple configurations, refer to the wiring diagram for S5bus and digital input connections. Daisy chaining is required **only** if all EVORA units need to be on the same S5bus or a parallel power design is needed for higher load capacity (See **Class 2 Output** table below).

### Master Contactor

Use for master contactor applications up to 30A. This assembly requires an external +12VDC source.



**Figure 7 EVORA WBI Master Contactor Wiring**

### WBI Power Supply

Use for applications where EVORA must be line powered but does not require load dimming or switching. 200mA DC output.

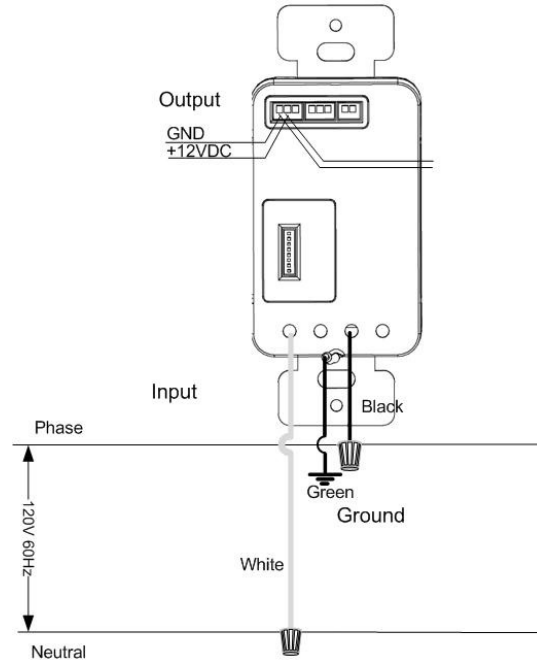

Figure 8 EVORA WBI Power Supply Wiring

### Low Voltage Adapter

The EVORA can be equipped with the Low Voltage Adapter (LVA). This allows the EVORA to act as a remote, +12VDC powered device only.

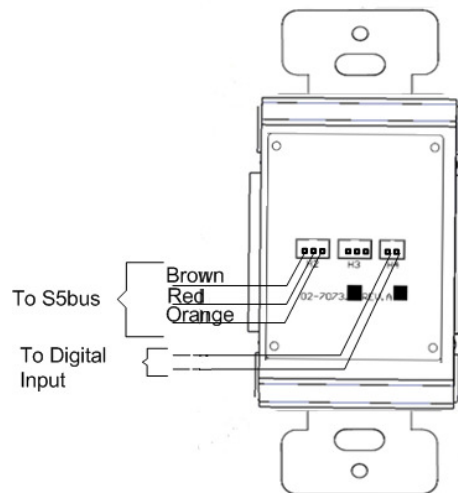

Figure 9 EVORA WBI Low Voltage Adapter Wiring

## Technical Specifications

User Interface	Tactile input
Maximum # of inputs	1-7 tactile keys
Alternate User Interface	Keypad—traditional mechanical switches
Communications	Wired S5bus 2.4Ghz RF
Input Power	12VDC, up to 250mA*
Audio	8 ohm, 0.5W speaker for door bell chime
Micro controller	16Mhz, 32-bit ARM based MCU
Dimensions	1 3/4" W x 1 3/4" D x 4" H (including brackets) 45 mm W x 45 mm D x 100 mm H (including brackets)

FCC ID: GTC202111TXR

This equipment has been tested and found to comply with the limits for a Class B digital device, pursuant to Part 15 of the FCC Rules. These limits are designed to provide reasonable protection against harmful interference in a residential installation. This equipment generates uses and can radiate radio frequency energy and, if not installed and used in accordance with the instructions, may cause harmful interference to radio communications. However, there is no guarantee that interference will not occur in a particular installation. If this equipment does cause harmful interference to radio or television reception, which can be determined by turning the equipment off and on, the user is encouraged to try to correct the interference by one of the following measures:

- Reorient or relocate the receiving antenna.
- Increase the separation between the equipment and receiver.
- Connect the equipment into an outlet on a circuit different from that to which the receiver is connected.
- Consult the dealer or an experienced radio/TV technician for help.

Any changes or modifications not expressly approved by the party responsible for compliance could void the user's authority to operate this equipment.

IC: 1609A-201217TXR

*This device complies with Industry Canada licence-exempt RSS standard(s). Operation is subject to the following two conditions: (1) this device may not cause interference, and (2) this device must accept any interference, including interference that may cause undesired operation of the device.*

*Le présent appareil est conforme aux CNR d'industrie Canada applicables aux appareils radio exempts de licence. L'exploitation est autorisée aux deux conditions suivantes: (1) l'appareil ne doit pas produire de brouillage, et (2) l'utilisateur de l'appareil doit accepter tout brouillage radioélectrique subi, même si le brouillage est susceptible d'en compromettre le fonctionnement.*

## Load Specifications

### Single Gang Installation

The following table provides the load ratings at absolute maximum based on the load type in a single gang wall box.

<i>Actuator</i>	<i>Ratings</i>			
	Voltage	Frequency	Power / Amperes	Load Type
SMPS	120-240Vac	50/60Hz	200mA	+12VDC Output Only
Relay Actuator	120-240 Vac	50/60 Hz	4.1 A	Resistive
	120-240 Vac	50/60 Hz	4.1 A	General Purpose
	120-240 Vac	50/60 Hz	500 W	Tungsten / ELV
	120-240 Vac	50/60 Hz	250 VA	Electric Ballast
	120 Vac	50/60 Hz	1/10 HP	Motor
TRIAC Dimmer	120 Vac	60 Hz	2.9 A	Resistive
	120 Vac	60 Hz	500 W	Tungsten / ELV
	120 Vac	60 Hz	250 VA	Electronic Ballast
	120 Vac	60 Hz	1/10 HP	Motor
MOSFET Dimmer	120 Vac	60 Hz	2.9 A	Resistive
	120 Vac	60 Hz	2.9 A	General Purpose
	120 Vac	60 Hz	350 W	Tungsten / ELV
	120 Vac	60 Hz	250 VA	Electronic Ballast
Master Contactor	120-240 Vac	50/60 Hz	7200VA	General Purpose
	120-240 Vac	50/60 Hz	960W	Tungsten / ELV
	120-240 Vac	50/60 Hz	800VA	Electronic Ballast
	120-240 Vac	50/60 Hz	30A	Resistive

### Class-2 Output

The Load Assembly has been designed to provide +12VDC power to devices connected to the S5bus. The Load Assemblies can operate in parallel to supply a higher total load capacity than that achievable by a single Load Assembly. However, the total output is derated as per the table below for accommodating the stability of the power supply circuitry. The total available output power must be shared with the EVORA User Interface. Refer to the following table for Class-2 Output ratings.

Number of Load Assemblies	Nominal Voltage	Voltage at Maximum Load	Output Rating
1	+12VDC	+11.0VDC	200mA
2	+12VDC	+11.0VDC	375mA
3	+12VDC	+11.1VDC	550mA
4	+12VDC	+11.1VDC	660mA
5	+12VDC	+11.2VDC	880mA
6	+12VDC	+11.2VDC	990mA



## Operating Conditions

Table Header	Table Header
Storage	68-176 degrees F; 20-80 degrees C, non-condensing
Operating	50-122 degrees F; 10-50 degrees C, non-condensing

## Ordering Information

The highly configurable EVORA product line features many options for function (programmable control, doorbell, nightlight), appearance, user interface, and Load Assembly. The Ordering Guide below is for the EVORA final assembly. For detailed ordering information for all EVORA components, see the EVORA Ordering Guide.

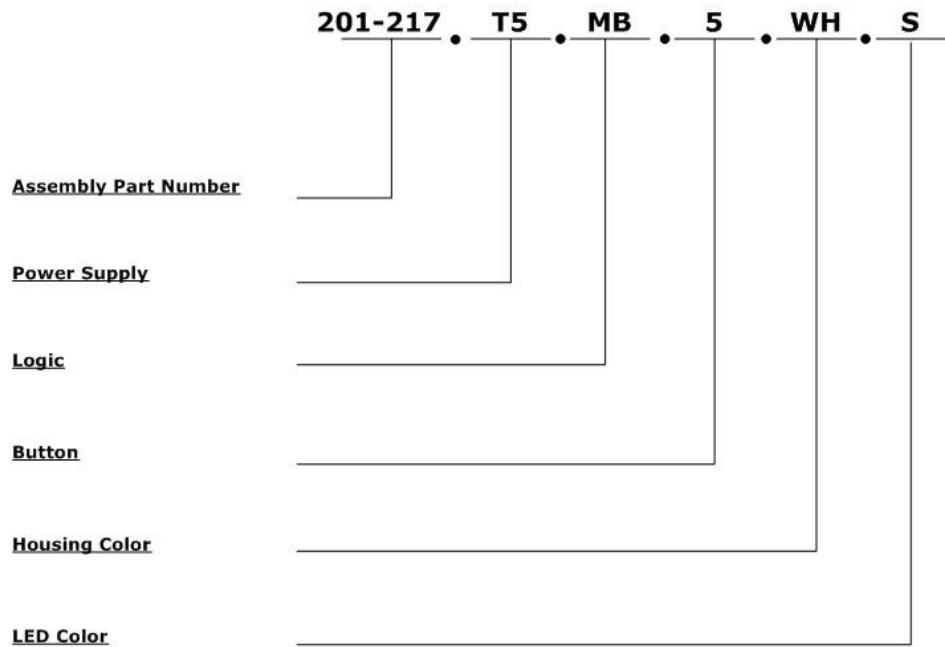

Description	Final Assembly OPN	Part Number
Multifunction/Doorbell		201-217
Nightlight		201-564

Description	Power Supply OPN	Part Number
500W TRIAC Dimmer	T5	03-7051
350W FET Dimmer	F3	03-7052
500W Relay Actuator	R5	03-7050
30A Master Contactor	3M	03-0310
200mA Power Supply	PS	03-7053
Low Voltage Adapter	LVA	03-7073

Description	Logic OPN	Part Number
1-5 button logic board w/radio	MB	202-111
2 button nightlight logic board w/ radio	NL	202-113
2 button logic board w/radio	DB	202-114

Description	Button OPN	Part Number
1, 2, 3, 3b, 4, 4b, 5 button (Nightlight and Doorbell are 2 button only)	-	-

Description	Housing Color OPN	Part Number
White	WH	
Black	BK	
Light Almond	LA	
Eagle Almond	EA	

## Document Revision History

Revision	Date Issued	Reason
0.1	10-Mar-2012	First draft
0.2	15-Mar-2012	Incorporated R&D review comments
0.3	22-Mar-2012	Updated drawings and Load Assembly text
1.0	23-Mar-2012	Incorporated Marketing comments and released
1.01	29-Jun-2012	Incorporate new load assemblies, order guide, IC statement
2.0	07-Sep-2012	Incorporate FCC statement changes and republish