

## INNCOM PC-502.1 Datasheet

### Overview

The INNCOM PC-502 wall mounted module can be used to expand the range of a network (IR or Layer-1 or Layer-2 RF) or to provide the protocol gateway from INNCOM S5-bus to Layer-1 or Layer-2 RF protocol.

In an IR network, the PC-502 module can be used to provide remote eye functionality or protocol gateway from INNCOM S5-bus to IR wireless protocols. The PC-502 adds functionality beyond the traditional remote eye because, as a smart 5-bus device, it can be powered from a standard 3-pin 5-bus connection.

In a Layer-1 RF network, the PC-502 provides S5-bus to RF protocol conversion, giving any INNCOM product participating in the INNCOM Integrated Room Automation System (IRAS) an RF transceiver for control of wireless products in the guestroom.

In the Deep Mesh 802.15.4 network, the PC-502 is designed to patch areas within the network where signal strength is lost due to distance limitations or interference. It also serves to create multiple pathways, increasing the redundancy of the mesh communications to ensure maximum network reliability.



**Figure 1 PC-502**

### Features

- Small wall mountable form factor
- 2.4Ghz IEEE 802.15.4 compliant RF transceiver (CC2430 radio core)
- Medium and long range variants available
- Industrial temperature ratings 0–65 degrees C
- FCC Part 15b listed

### Specification

Parameter	PC-502.1
RF Data Rate	250kbps
Antenna Type	SMT
Indoor Range	70ft
Outdoor/ RF line-of-sight range	540ft
Transmit Power	1mW (+0dBm)
Receive Sensitivity	-94.6dBm
Frequency Band	2.4Ghz
Encryption	AES-128
Protocol	802.15.4
Frequency Channels	11-26
Input Voltage	12VDC
Current Consumption	50mA (Peak)
Operating Ambient Temperature	0°C

## Network Topology

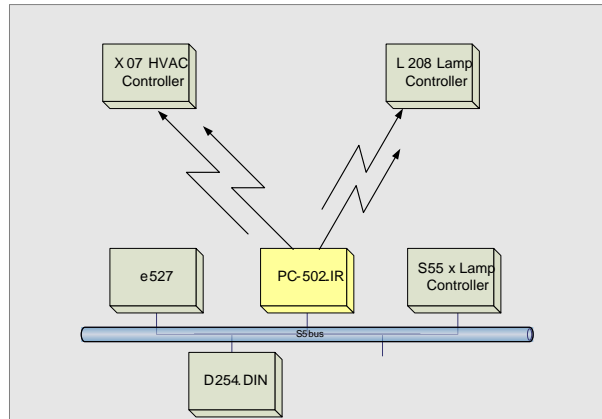

**Figure 2 PC-502.IR Topology**

In this application, the PC-502 provides S5-bus to IR protocol conversion giving any INNCOM product participating in the INNCOM Integrated Room Automation System (IRAS) an IR transceiver for control of wireless products in the guestroom.

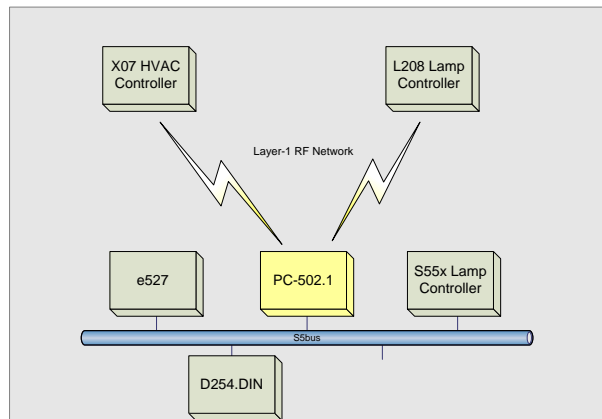

**Figure 3 PC-502 Layer-1 Topology**

In this application, the PC-502 is providing S5-bus to RF protocol conversion, giving any INNCOM product participating in the INNCOM Integrated Room Automation System (IRAS) an RF transceiver for control of wireless products in the guestroom.

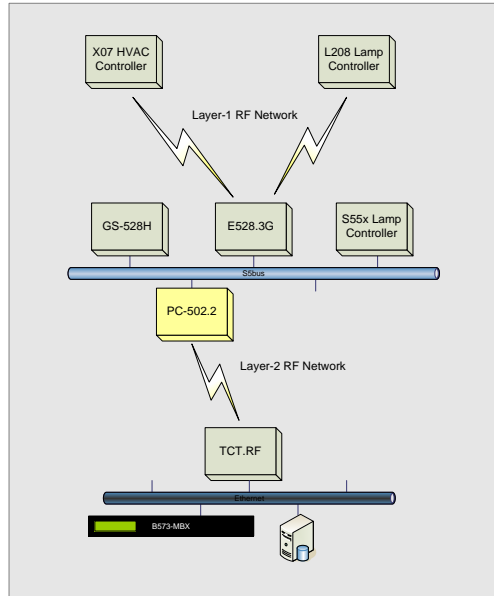

**Figure 4 PC-502 Layer-2 Topology**

In this application, the PC-502 in participation with the e528.3G provides the Layer-1 to Layer-2 RF Bridge where both wireless in-room and wireless back-end networking are required. The PC-502 can also patch areas within the Layer-2 network where signal strength is lost due to distance limitations or interference.

## Safety/Regulatory

Parameter	Condition	Status
FCC	Part 15b	FCC ID: GTC202124TXR

## Warning

Any Changes or modifications not expressly approved by the party responsible for compliance could void the user's authority to operate the equipment.

This device complies with part 15 of the FCC Rules. Operation is subject to the following two conditions: (1) This device may not cause harmful interference, and (2) this device must accept any interference received, including interference that may cause undesired operation.

## FCC & ICC Compliance Statements

This equipment has been tested and found to comply with the limits for a Class B digital device, pursuant to Part 15 of the FCC Rules. These limits are designed to provide reasonable protection against harmful interference in a residential installation. This equipment generates uses and can radiate radio frequency energy and, if not installed and used in accordance with the instructions, may cause harmful interference to radio communications. However, there is no guarantee that interference will not occur in a particular installation. If this equipment does cause harmful interference to radio or television reception, which can be determined by turning the equipment off and on, the user is encouraged to try to correct the interference by one of the following measures:

- Reorient or relocate the receiving antenna.
- Increase the separation between the equipment and receiver.
- Connect the equipment into an outlet on a circuit different from that to which the receiver is connected.
- Consult the dealer or an experienced radio/TV technician for help.

Any changes or modifications not expressly approved by the party responsible for compliance could void the user's authority to operate this equipment.

IC:1609A-202124TXR

This device complies with Industry Canada licence-exempt RSS standard(s). Operation is subject to the following two conditions: (1) this device may not cause interference, and (2) this device must accept any interference, including interference that may cause undesired operation of the device.

Le présent appareil est conforme aux CNR d'industrie Canada applicables aux appareils radio exempts de licence. L'exploitation est autorisée aux deux conditions suivantes: (1) l'appareil ne doit pas produire de brouillage, et (2) l'utilisateur de l'appareil doit accepter tout brouillage radioélectrique subi, même si le brouillage est susceptible d'en compromettre le fonctionnement.

## IMPORTANT NOTE: PC-502 Dimensions

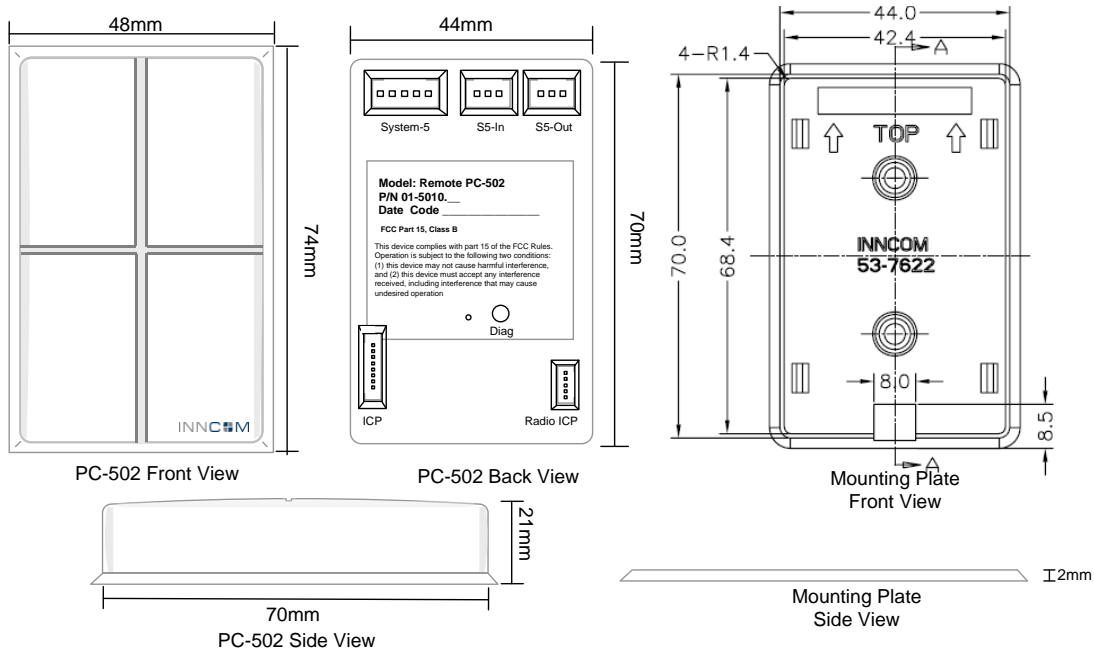

## Header and Connections

### H3 (In System Programming)

Pin	Function	Type	Min	Max
1-8	Programming	-	-	-

### H4 / H5 (S5-bus In/Out)

Pin	Function	Type	Min	Max
1-GND	Common	-	-	-
2-12VDC	Input voltage	In	11.75	12.25
3-S5-bus	Multi-drop	In/Out	-	-

### H6 (System-5)

Pin	Function	Type	Min	Max
1-GND	Common	-	-	-
2-12VDC	Input voltage	In	11.75	12.25
3-S5-bus	Multi-drop	In/Out	-	-

<b>4 -InOut1</b>	TTL	In/Out	-
<b>5- InOut2</b>	TTL	In/Out	-

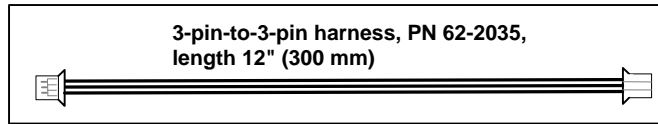

3-pin to 3-pin harness for 12VDC and 5-bus connection

## Ordering Information

Part Number	OPN	Description
201-502.1	PC-502.1	PC-502 with 0dB Transceiver

## Document Revision History

Revision	Date Issued	Reason
0.1	14-May-2013	FCC for PC-502