

---

## Low cost RF Module (LCRM) - User Manual

Product Manual

For RF Module part numbers,

Radio Assembly: 51306799

Printed wiring board no: 51306798

2.4GHz, 802.15.4 Module

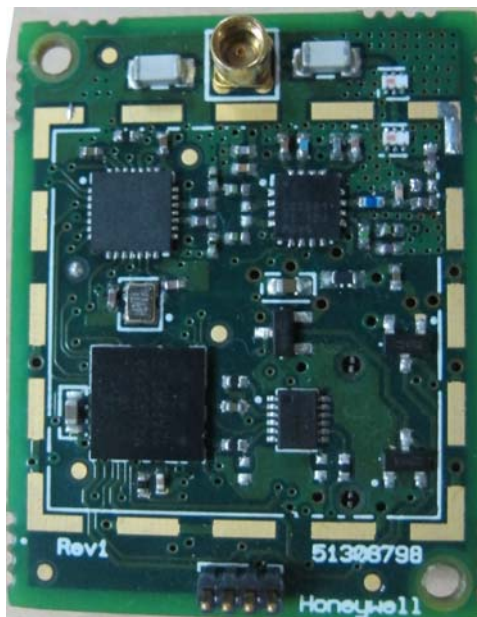

**Copyright 2013 by Honeywell International Inc.**

**Revision 3, April 28, 2013**

---

## Document Revision History

Date	Author	Description/Changes	Revision
Feb 22, 2011	Abhijit	Initial	1.0
May 30, 2011	Biswas	Modified after Review with TUV	2.0
April 28, 2013	Antony	Re-Released for C2PC	3.0

---

## Contents

<b>1. COMPLIANCE STATEMENTS:</b> .....	<b>4</b>
1.1 FCC COMPLIANCE STATEMENTS .....	4
1.2 IC COMPLIANCE STATEMENTS .....	5
<b>2. DESCRIPTION:</b> .....	<b>6</b>
<b>3. FEATURES:</b> .....	<b>6</b>
<b>4. ELECTRICAL CHARACTERISTICS</b> .....	<b>6</b>
<b>5. PIN OUT DETAILS</b> .....	<b>6</b>
<b>6. MECHANICAL SPECIFICATION</b> .....	<b>7</b>
<b>7. CONFIGURATION SOFTWARE</b> .....	<b>8</b>
<b>8. APPROVED ANTENNA TYPES/ GAINS</b> .....	<b>8</b>
<b>9. SETTING TX POWER</b> .....	<b>9</b>
<b>10. INSTRUCTION TO OEM INSTALLER</b> .....	<b>10</b>
<b>11. LIMITED MODULAR APPROVAL</b> .....	<b>11</b>
<b>12. AGENCY LABEL INFORMATION</b> .....	<b>11</b>

---

# 1. Compliance Statements:

## 1.1 FCC Compliance Statements

This device complies with Part 15 of the FCC rules. Operation is subject to following two conditions:

1. This device may not cause harmful interference and
2. This device must accept any interference received including interference that may cause undesired operation of this device.

The changes or modifications not expressly approved by the party responsible for compliance could void the user's authority to operate the equipment.

To comply with the FCC RF exposure compliance requirements, this device and its antenna must not be co-located or operating to conjunction with any other antenna or transmitter, except if installed in compliance with FCC Multi Transmitter procedures.

To inherit the modular approval, the antennas for this transmitter must be installed to provide a separation distance of 20cm from all persons and must not be co-located or operating in conjunction with any other antenna or transmitter

### To OEM Installer:

1. FCC ID on the final system must be labeled with "Contains FCC ID: S5751306799" Or "Contains transmitter module FCC ID: S5751306799".
2. In the user manual, final system integrator must ensure that there is no instruction provided in the user manual to install or remove the transmitter module.
3. Transmitter module must be installed used in strict accordance with the manufacturer's instructions as described in the user documentation that comes with the product.

The user manual of the final host system must contain the following statements:

This device complies with Part 15 of the FCC rules. Operation is subject to following two conditions: 1. This device may not cause harmful interference and 2. This device must accept any interference received including interference that may cause undesired operation of this device.

The changes or modifications not expressly approved by the party responsible for compliance could void the user's authority to operate the equipment.

To comply with the FCC RF exposure compliance requirements, this device and its antenna must not be co-located or operating to conjunction with any other antenna or transmitter, except if installed in compliance with FCC Multi Transmitter procedures.

To inherit the modular approval, the antennas for this transmitter must be installed to provide a separation distance of at least 20cm from all persons and must not be co-located or operating in conjunction with any other antenna or transmitter

### Note:

The buyer of the module who will incorporate this module into his host must submit the final product to the manufacturer of the module and the MANUFACTURER OF THE MODULE WILL VERIFY that the product is incorporated in host equipment in a way that is represented by the testing as shown in the test report.

---

## 1.2 IC Compliance Statements

Operation is subject to the following two conditions:

1. This device may not cause interference, and
2. This device must accept any interference, including interference that may cause undesired operation of the device.

Under Industry Canada regulations, this radio transmitter may only operate using an antenna of a type and maximum (or lesser) gain approved for the transmitter by Industry Canada. To reduce potential radio interference to other users, the antenna type and its gain should be so chosen that the equivalent isotropically radiated power (e.i.r.p.) is not more than that necessary for successful communication.

Conformément à la réglementation d'Industrie Canada, le présent émetteur radio peut fonctionner avec une antenne d'un type et d'un gain maximal (ou inférieur) approuvé pour l'émetteur par Industrie Canada.

Dans le but de réduire les risques de brouillage radioélectrique à l'intention des autres utilisateurs, il faut choisir le type d'antenne et son gain de sorte que la puissance isotrope rayonnée équivalente (p.i.r.e.) ne dépasse pas l'intensité nécessaire à l'établissement d'une communication satisfaisante.

This radio transmitter has been approved by Industry Canada to operate with the antenna types listed below with the maximum permissible gain and required antenna impedance for each antenna type indicated. Antenna types not included in this list, having a gain greater than the maximum gain indicated for that type, are strictly prohibited for use with this device.

Le présent émetteur radio a été approuvé par Industrie Canada pour fonctionner avec les types d'antenne énumérés ci-dessous et ayant un gain admissible maximal et l'impédance requise pour chaque type d'antenne. Les types d'antenne non inclus dans cette liste, ou dont le gain est supérieur au gain maximal indiqué, sont strictement interdits pour l'exploitation de l'émetteur.

To inherit the modular approval, the antennas for this transmitter must be installed to provide a separation distance of at least 20cm from all persons and must not be co-located or operating in conjunction with any other antenna or transmitter

**Note:**

The buyer of the module who will incorporate this module into his host must submit the final product to the manufacturer of the module and the MANUFACTURER OF THE MODULE WILL VERIFY that the product is incorporated in host equipment in a way that is represented by the testing as shown in the test report.

---

## 2. Description:

Low Cost ISA100 Radio Module is 2.4GHz band 802.15.4 Radio. This module includes 16 Bit Microcontroller which is interfaced to a 802.15.4 compliant Radio Transceiver to provide Wireless communication over 15Channels of 2.4GHz band. The module also includes RF Power Amplifier and RF Low Noise Amplifier to enhance the range of Wireless communications. The Module can communicate with the target boards through its connector over SPI. It can send out or receive, data - sent by or sent to, the target board through this SPI connection. Protocol specific Modulation/De-Modulation is done in radio transceiver and the 802.15.4 packet is taken care by Radio Transceiver on the Module.

## 3. Features:

- Operating frequency : 2.4 to 2.483GHz
- No. of channel : 15
- Channel spacing : 5MHz (2405,2410,.....2475)
- Transmitted power : -7 to +20dBm (adjusted as per antenna)
- Modulation : DSSS
- Data rate : 250kbps

## 4. Electrical Characteristics

- Operating Voltage : 2.7V to 3.6V
- Operating Temperature : -40 deg C to +85 deg C.
- Current Consumption:
  - Receive Mode (Rx) : 33mA
  - Transmit Mode(Tx) : 220mA
  - Sleep Mode : 13uA

Absolute Maximum Ratings	
Voltage Applied	3.6
Storage Temperature	-50°C to +105°C
Operating Temperature	-40°C to +85°C

## 5. Pin out Details

1 GND	2 GND
3 I/O	4 I/O
5 SPI_CLK	6 SPI_MISO
7 SPI_MOSI	8 SPI_CS
9 VCC	10 VCC

Table 1 Pin Out

## 6. Mechanical Specification

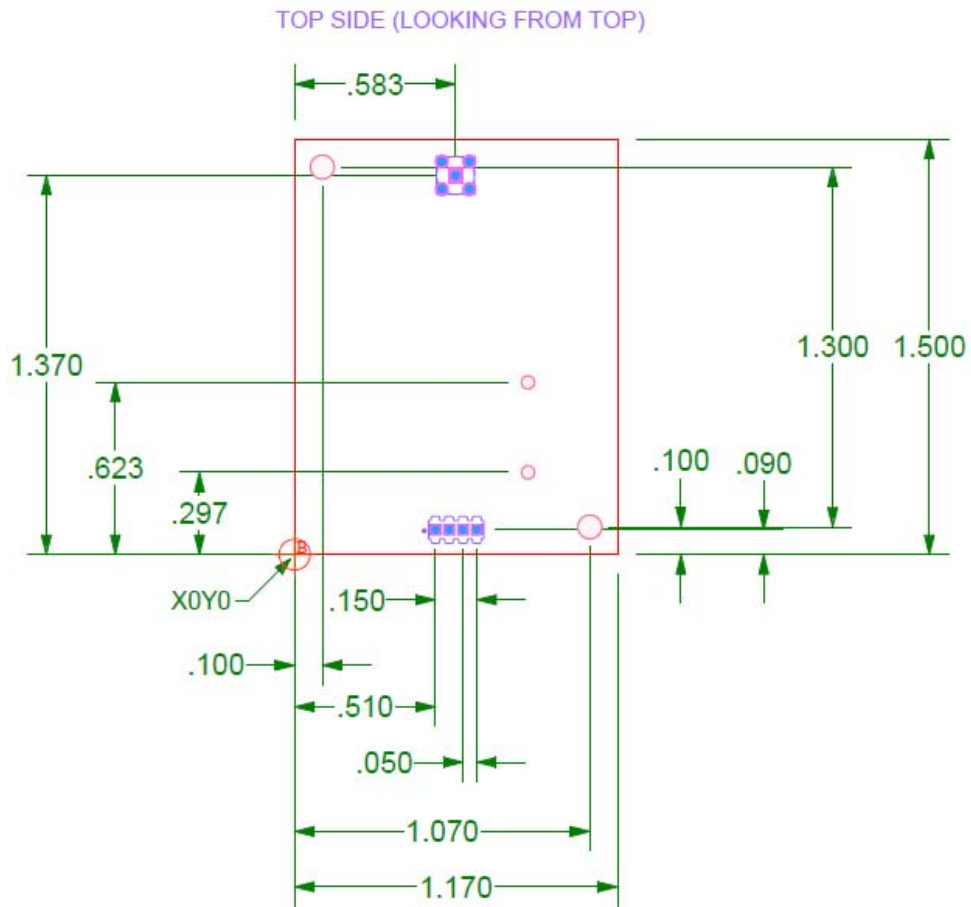

NOTE: ALL UNITS ARE IN "INCHES"

MOUNTING HOLE: "2.2mm"

BOTTOM SIDE (LOOKING FROM TOP)

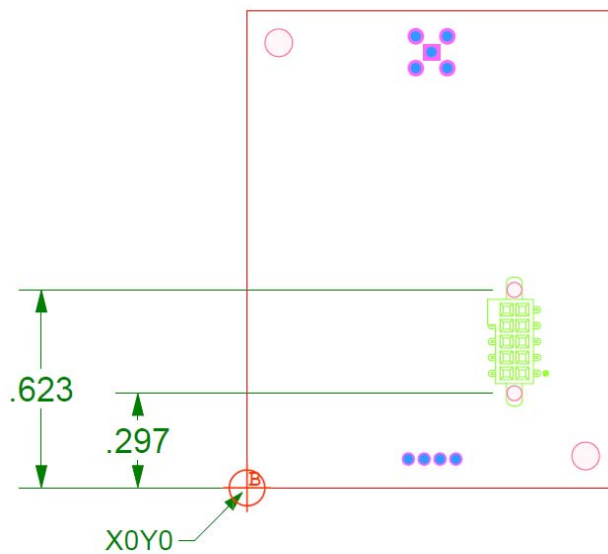

---

## 7. Configuration Software

The radio platform can host multiple standard protocol stacks like ISA100, zigbee, 802.15.4 pt to pt and any proprietary protocol stack which could use the same hardware platform running on 802.15.4 physical layer. The configuration parameters for power level, frequencies are adjusted as per the antenna table used during compliance tests. For compliance tests, test software running hyper terminal is used to configure the power levels for the different antenna as per the Table 2. The commands shall be available through host application to communicate to the radio module for configuration of Tx power levels.

The power levels are configured in the registers of radio transceiver used on the module and adjusted as per Table 2. The frequencies i.e 15 channels are pre-defined as per 802.15.4 arrangement in 2.4GHz band excluding the last channel i.e 16<sup>th</sup> channel, 2480MHz.

## 8. Approved Antenna Types/ Gains

Antenna Number	Make	Model	Antenna Gain (dBi)	Power Level Setting (dBm)
Antenna 1	Hyperlink	WHON511-0001	4	15
Antenna 2	Antenna Factor	ANT2.4OEMHSC002V1	2.2	15
Antenna 3	Antenna Factor	ANT2.4OEMHSC001V1	2.2	15
Antenna 4	Antenna Factor	ANT-DB1-VDP-RPS	3.0	15
Antenna 5	L-COM/Hyperlink	HG2405RD-RSP	5.5	11
Antenna 6	Centurion	MAF94152	-2.0	20
Antenna 7	L-COM/Hyperlink	HG2409RD-RSP	9.0	11
Antenna 8	Hyperlink	HGV-2409U	8.0	15
Antenna 9	L-COM/Hyperlink	HG2475U-RNJ	8.0	15
Antenna 10	Hyperlink	HG2414P-120	14.0	11
Antenna 11	L-Com	HG2402RDR-RSP	2.2	15
Antenna 12	LairdTech	RD2458-5-OTDR-NM	3.0	15
Antenna 13	LairdTech	OD24M-5	5.0	15

**Table 2 Antenna Vs Transmit Power List**

**Antenna 2, 3, 4, 5, 7 & 11 are with Reverse SMA connector.**

**Antenna 1, 8, 9, 10, 12 & 13 are with N type connector.**

**Antenna 6 is with MMCX type connector.**



---

## 9. Setting Tx Power

**Warning!** The Low Cost ISA100 Radio Module must be Professionally Installed in accordance with the requirements specified in this document. Only the specified power Settings, antenna types and gains as outlined in this document are valid for Low Cost ISA100 Radio Module installation.

The Tx power settings for the radio module are to be configured using a host interface with the module. The module has an SPI communication interface which can communicate to any host carrier. The power settings are provided as configurable parameter through host interface. The configurable parameter will be in terms of RF output power in dBm available at the connector output of the radio board as given in the figures below,

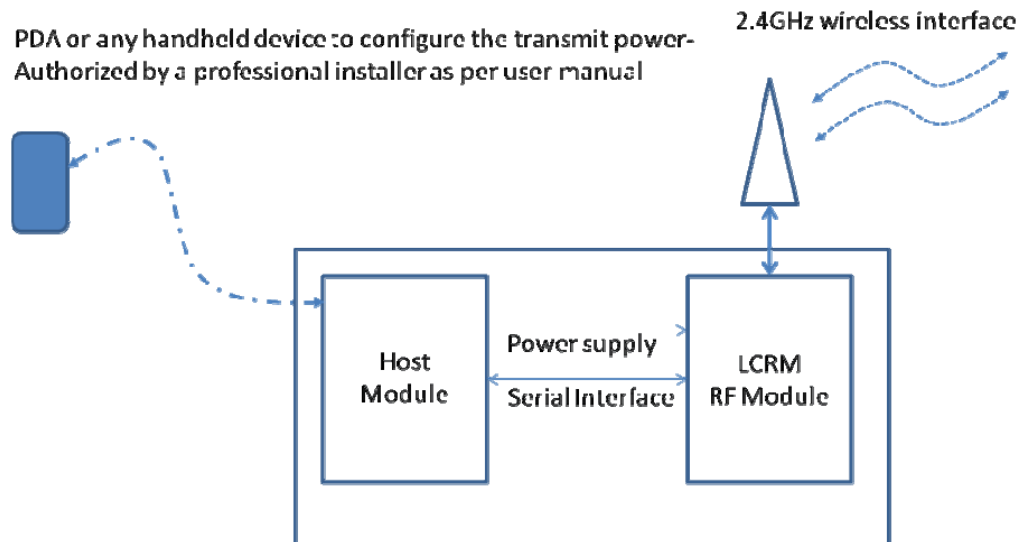

Alternatively power levels can be preconfigured in LCRM RF module in factory as per the antenna combination being shipped out with the product.

LCRM module can host different types of communication stack software like ISA100, Zigbee, 15.4 pt to pt etc..which can typically use 15.4 physical layer for the wireless communication. Irrespective of the communication stack being ported on the LCRM module, the basic configurations of channels and power levels as per the antenna shall remain same as given in the user manual. As explained above, this can be either done through a professional installation at the field or through a preconfigured power level with a particular antenna combination shipped out from factory.

Professional installation has to be done by a person who has sufficient knowledge about settings of radio parameters of the module. It will void OEM installers authority to operate and sell the equipment if this is done incorrectly.

---

The power level configurable are given in Table 3

S.No	Power level
1	20dBm
2	19dBm
3	18dBm
4	17dBm
5	15dBm
6	14dBm
7	12dBm
8	11dBm
9	10dBm
10	6dBm
11	4dBm
12	3dBm
13	1dBm
14	0dBm
15	-1dBm
16	-5dBm

**Table 3 Power Level Supported by LCRM**

## 10. Instruction to OEM installer

OEM installer shall refer user manual for configuration of transmit power for type of antenna as given in Table 2.

The antennas listed in Table 2 includes N type connector, Reverse SMA connector and MMCX connector. Installer shall use only the antennas which are listed in the table to comply with FCC regulations.

Integrators of this module in their end product are instructed to glue the N type antenna connector to the socket of the final product.

For the final product OEM installer must ensure that the power settings of the module are not end user accessible.

When integrated into OEM products, fixed antennas require installation preventing end-users from replacing them with non-approved antennas. Antennas not listed in the tables must be tested to comply with FCC Section 15.203 (unique antenna connectors) and Section 15.247 (emissions).

For non-approved antennas, each installation of the module in the host must be approved by a class II permissive change by the TCB/FCC through Honeywell.

---

## 11. Limited modular approval

This is an RF module approved for limited modular use limited to OEM installation for mobile and fixed applications only. Final antenna installation in the product and operating configurations of the transmitter including antenna gain and cable loss shall comply with FCC regulations. Honeywell must coordinate with OEM integrators to ensure the end-users and installers of products operating with the module are provided with operating instructions to satisfy RF exposure requirements. Integrators are instructed to ensure the end-user has no manual instructions to remove, adjust or install the device.

## 12. Agency Label Information

### FCC/IC Labels

<p><b>RF MOD 51306799-001</b> <b>FCC ID: S5751306799</b> <b>IC ID: 573I-51306799</b></p>
--