

L8124A,C,E,L and M Aquastat® Relays

INSTALLATION INSTRUCTIONS

APPLICATION

These immersion type controllers are used with forced hydronic heating systems that include domestic hot water service. All models provide high limit, low limit and circulator control. Table 1 lists the various models and their applications.

These Aquastat® relays have a diaphragm powerhead and MicroSwitch™ assembly that respond to temperature changes in the boiler water. L8124 can provide multizone control by using a separate circulator and R845 Relay for each zone. L8124E and L have large transformers and extra terminals for supplying power to low voltage valves. L8124L includes a large transformer and extra terminals for low voltage zone valves. L8124M is for use in a wood-coal/gas-oil multifuel heating system. Circulator is independently controlled by the thermostat.

Do not use these Aquastat® Relays where the pressure can exceed 100 psi (690 kPa) on the bulb if inserted directly or 200 psi (1380 kPa) when using an immersion well, or where the ambient temperature can exceed 150°F (66°C) at the case or 265°F (129°C) at the sensing element.

SPECIFICATIONS

Low Limit:

Setting: 110°F to 220°F (43°C to 104°C), adjustable.
Differential: 10°F to 25°F (6°C to 14°C), adjustable.

High Limit:

Setting: 130°F to 240°F (54°C to 116°C), adjustable.
Differential: 10°F (6°C), fixed.

WARNING

Explosion Hazard.

Can cause serious injury, death or property damage.

Use this product only in systems with a pressure relief valve.

Table 1. Model Descriptions.

Model Number	Burner Control Circuit	Can Be Used For Multizone With Circulators ^a	No. of V8043 Zone Valves Powered Without Additional Transformer	Electrical Ratings	
				Burner Circuit	Circulator Circuit
L8124A	120V	Yes	—	Same as L8124A,C,L circulator rating.	120 Vac: 7.4A (full load), 44.4A (locked rotor). 240 Vac: 3.7A (full load), 22.2A (locked rotor).
L8124C			—		
L8124L			3		
L8124E	24V		2	1.25A at 24 Vac; 30 VA (total load) B ₁ -B ₂ , T _V -Z.	
L8124M	120V		—	Same as L8124A.	None.

^a Multizone control can be provided by using a separate circulator and R845 Relay for each zone.



INSTALLATION

When Installing This Product...

1. Read these instructions carefully. Failure to follow them could damage the product or cause a hazardous condition.
2. Check the ratings given in the instructions and on the product to make sure the product is suitable for your application.
3. Installer must be a trained, experienced service technician.
4. After installation is complete, check out product operation as provided in these instructions.

⚠ WARNING

Electrical Shock Hazard.
Can cause severe injury, death or equipment damage.

Disconnect power supply before beginning installation to prevent electrical shock or equipment damage.

IMPORTANT

1. Terminals on these Aquastat Relays are approved for copper wire only.
2. Immersion well must fit sensing element and bulb must rest against bottom of well.

Bend the tubing, if necessary, to hold the bulb against the bottom of the well. Do not make a sharp bend in the tubing. A sharp bend can produce a break in the tubing and cause loss of fill. This condition will cause the high and low limit controllers to be continuously made.

Select models have an adjustable capillary length. See Fig. 1.

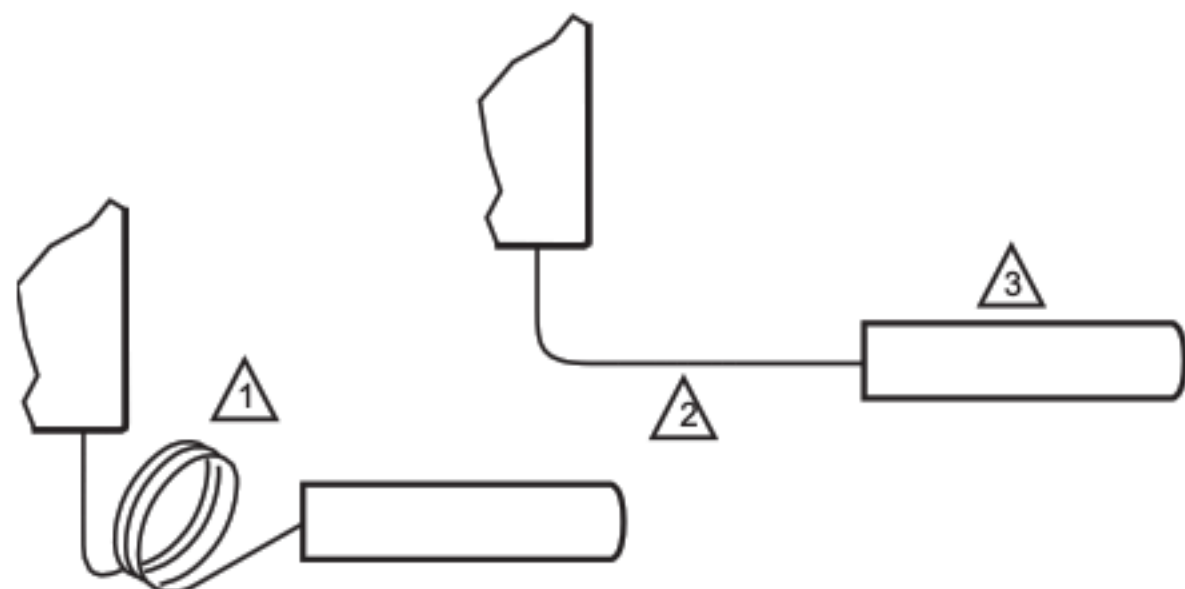

⚠ CAUTION:
EXCESSIVE HANDLING OR SHARP BENDS
CAN DAMAGE THE CAPILLARY.

① SENSING ELEMENT IS FACTORY FORMED FOR 1.5 IN.
INSULATION WELL ASSEMBLIES.

② FOR 3 IN. INSULATION WELL ASSEMBLIES, PULL OUT
SUFFICIENT CAPILLARY TO ASSURE THAT THE CAPSULE
BOTTOMS IN THE WELL.

③ STRAIGHTEN CAPILLARY SUFFICIENTLY SO IT DOES NOT
INTERFERE WITH INSERTION OF THE CAPSULE INTO THE WELL. M8882

Fig. 1. Adjusting the capillary length.

Mounting

Each relay is suitable for use with an immersion well for insertion into the boiler. (Check individual OS number specifications to determine whether a well is supplied

with the relay.) Refer to form 68-0040, Wells and Fittings for Temperature Controllers, to order well. A compression fitting is available for applications where direct immersion of the sensing bulb is desired. A 124904 Well Adapter (see Fig. 2) can be ordered separately to adapt some other wells to the mounting clamp. The boiler must be provided with a tapping that allows horizontal mounting of the well. It should be located where boiler water of average temperature can circulate around the well.

1. Turn off all power and drain the boiler.
2. If no tapping is provided, prepare one, properly sized and threaded, at the selected location.
3. Install the immersion well in the boiler tapping and tighten securely.

NOTE: Do not use the case as a handle to tighten.

4. Refill boiler and check for water leakage.
5. Loosen but do not remove the clamp screw on the bottom (L8124A,E) or on top (L8124C,L,M) of case.
6. Insert the element in the well until it bottoms. See Fig. 2.
7. Fit the case onto the well so that the clamp on the case slides over the flange on the well. Securely tighten clamp screw.

WIRING

⚠ WARNING

Electrical Shock Hazard.
Can cause severe injury, death or equipment damage.

Disconnect power before wiring to prevent electrical shock or equipment damage.

All wiring must comply with local electrical codes and ordinances. The limits given in the Specifications section must not be exceeded when applying this control. Terminals on these Aquastat Relays are approved for copper wire only.

Refer to the insert on the inside of the Aquastat Relay cover or to Table 1 for electrical ratings and maximum load information. Use manufacturer instructions when wiring controlled equipment or refer to typical hookups in Fig. 3 through 11.

⚠ WARNING

Explosion Hazard.
Can cause severe injury, death or property damage.

Use this product only in systems with a pressure relief valve.

If the B1 terminal on the device being replaced is a 1/4 in. (6 mm) tab terminal, use the existing wiring harness terminals to install the replacement device. If the B1 terminal on the device being replaced is a screw terminal, insert the provided tab terminal to screw terminal adapter on the 1/4 in. (6 mm) tab terminal of the replacement device. After the adapter is installed, the existing wraparound wire end may be reused to make an electrical connection to the B1 terminal.

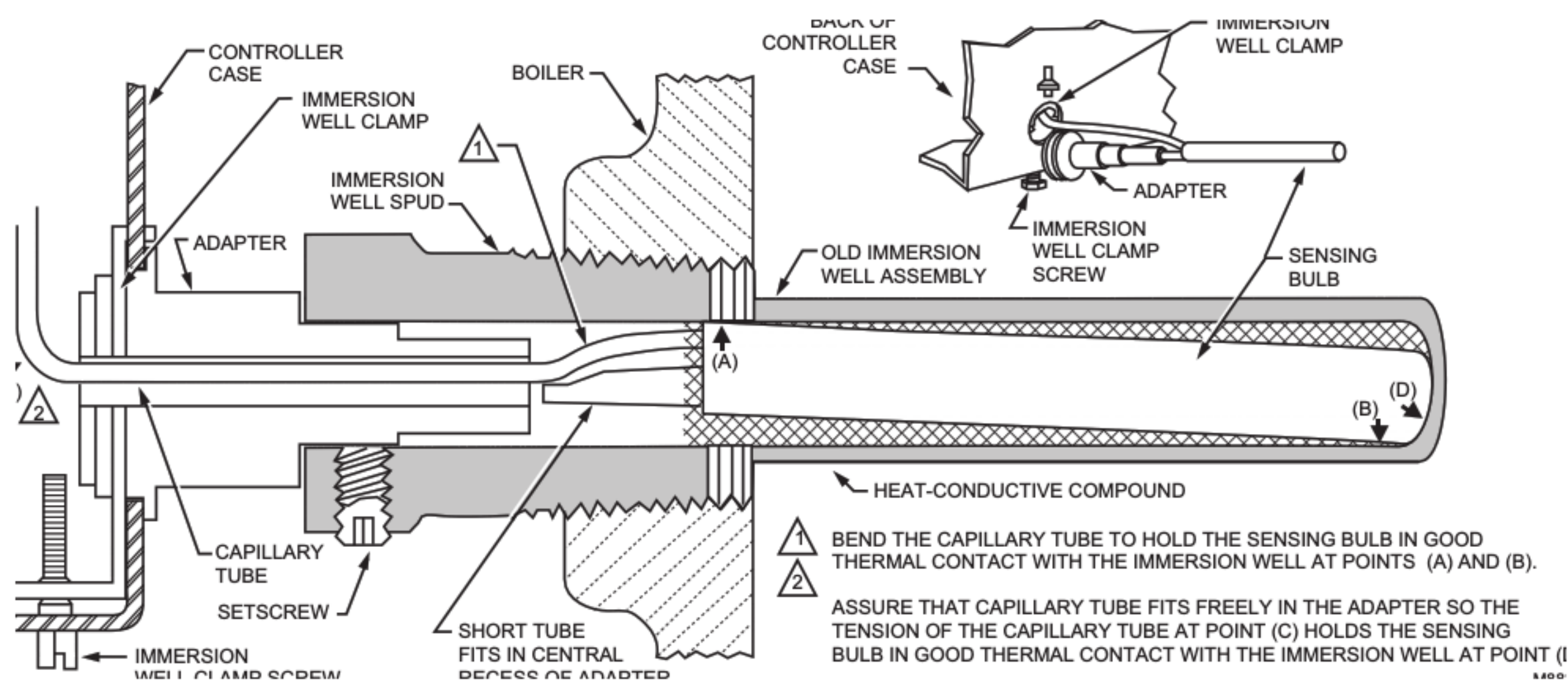

Fig. 2. Position of bulb in immersion well and use of well adapter when required.

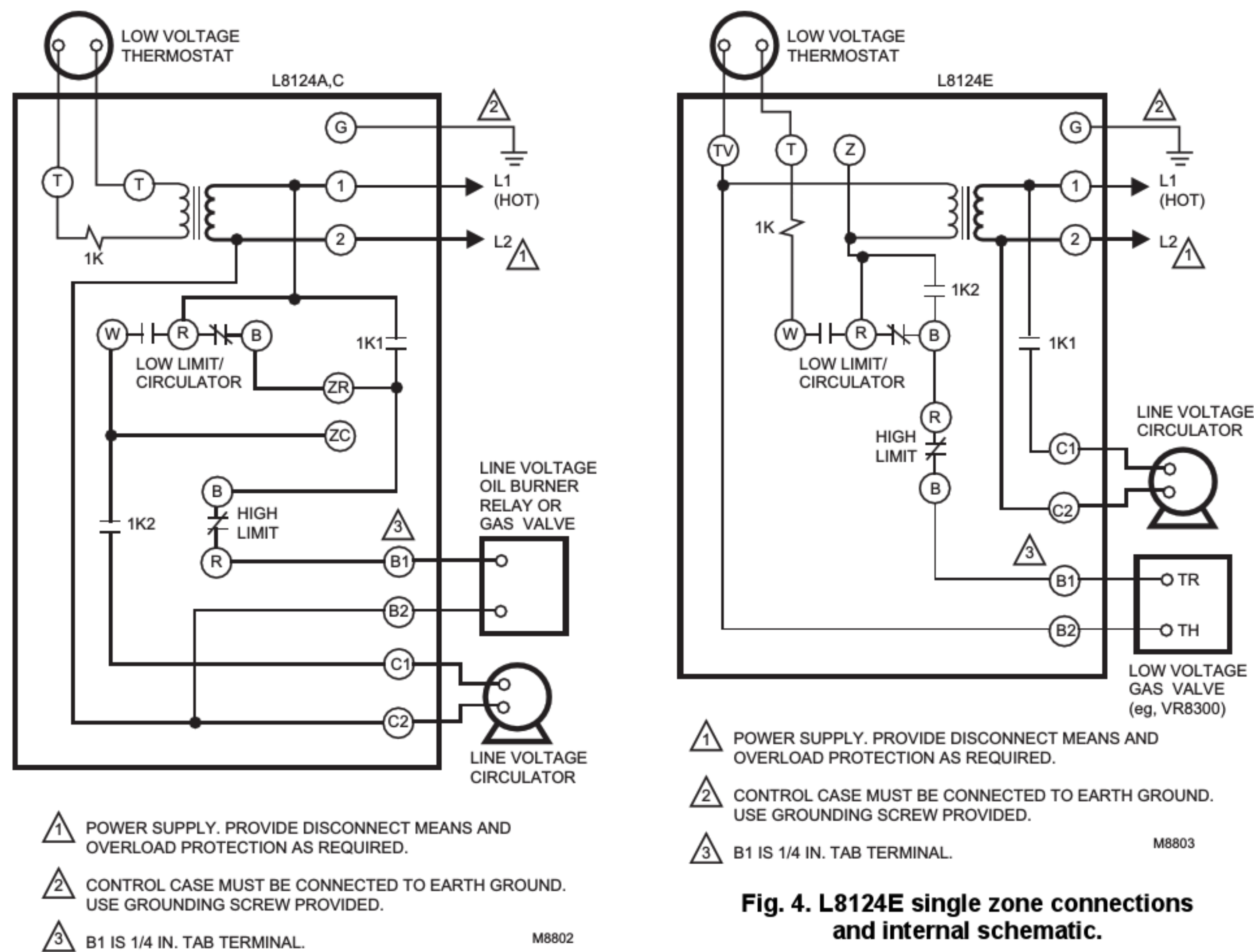

Fig. 3. L8124A,C single zone connections and internal schematic.

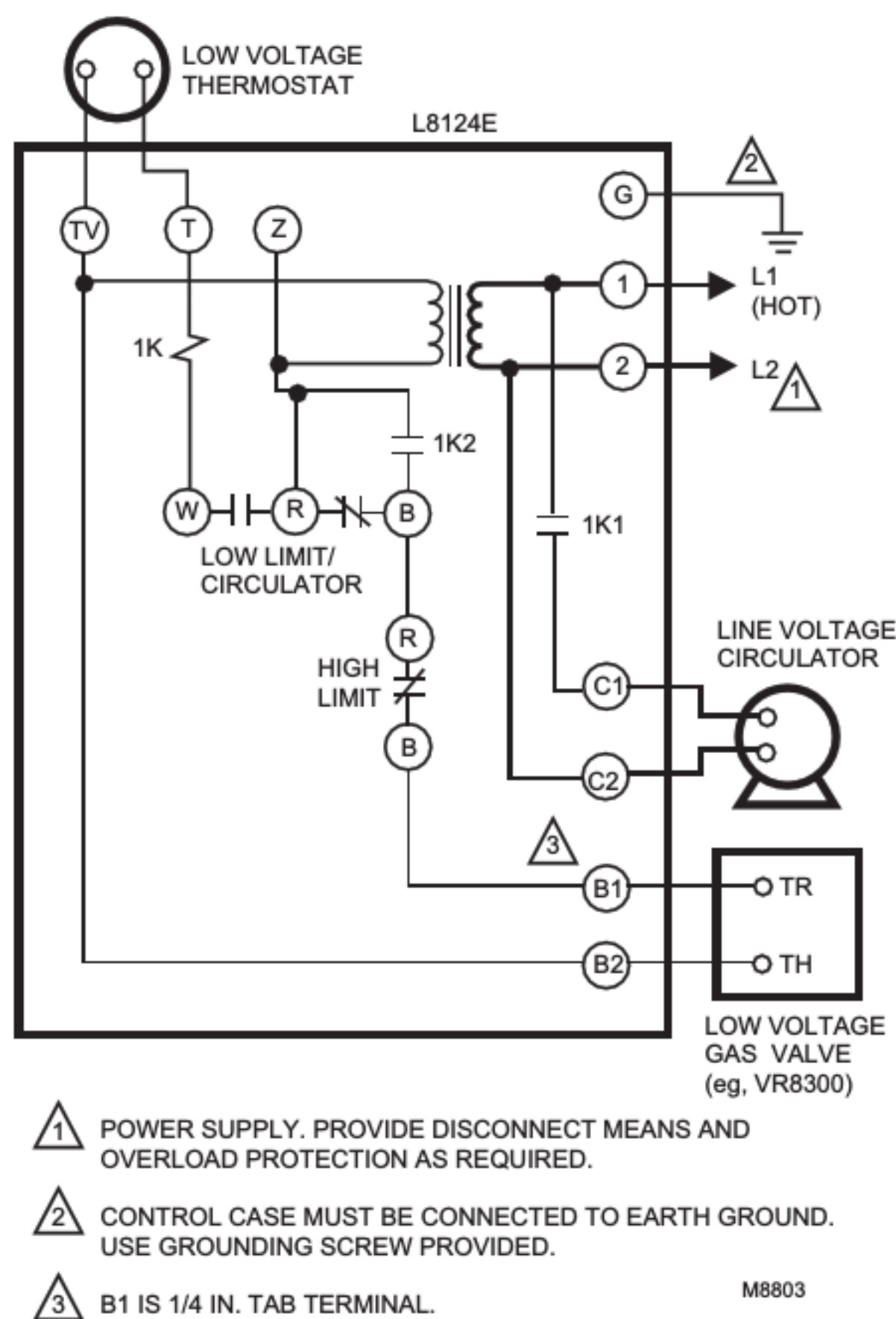
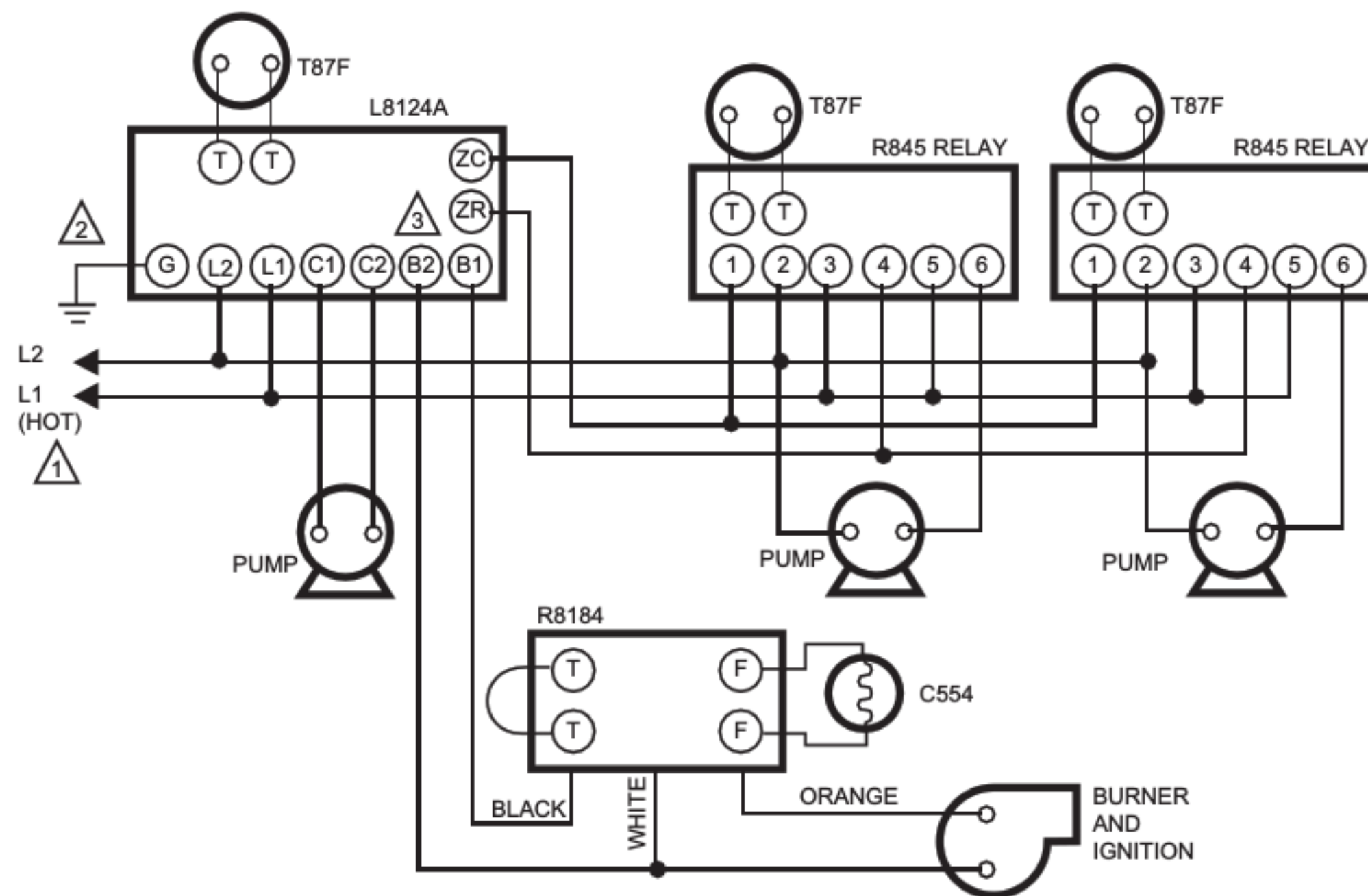

Fig. 4. L8124E single zone connections and internal schematic.



- ⚠️ 1 POWER SUPPLY. PROVIDE DISCONNECT MEANS AND OVERLOAD PROTECTION AS REQUIRED.
- ⚠️ 2 CONTROL CASE MUST BE CONNECTED TO EARTH GROUND. USE GROUNDING SCREW PROVIDED.
- ⚠️ 3 B1 IS 1/4 IN. TAB TERMINAL.

M8822

Fig. 5. L8124A in an oil-fired, forced hot water, tankless, zoned, pump system.

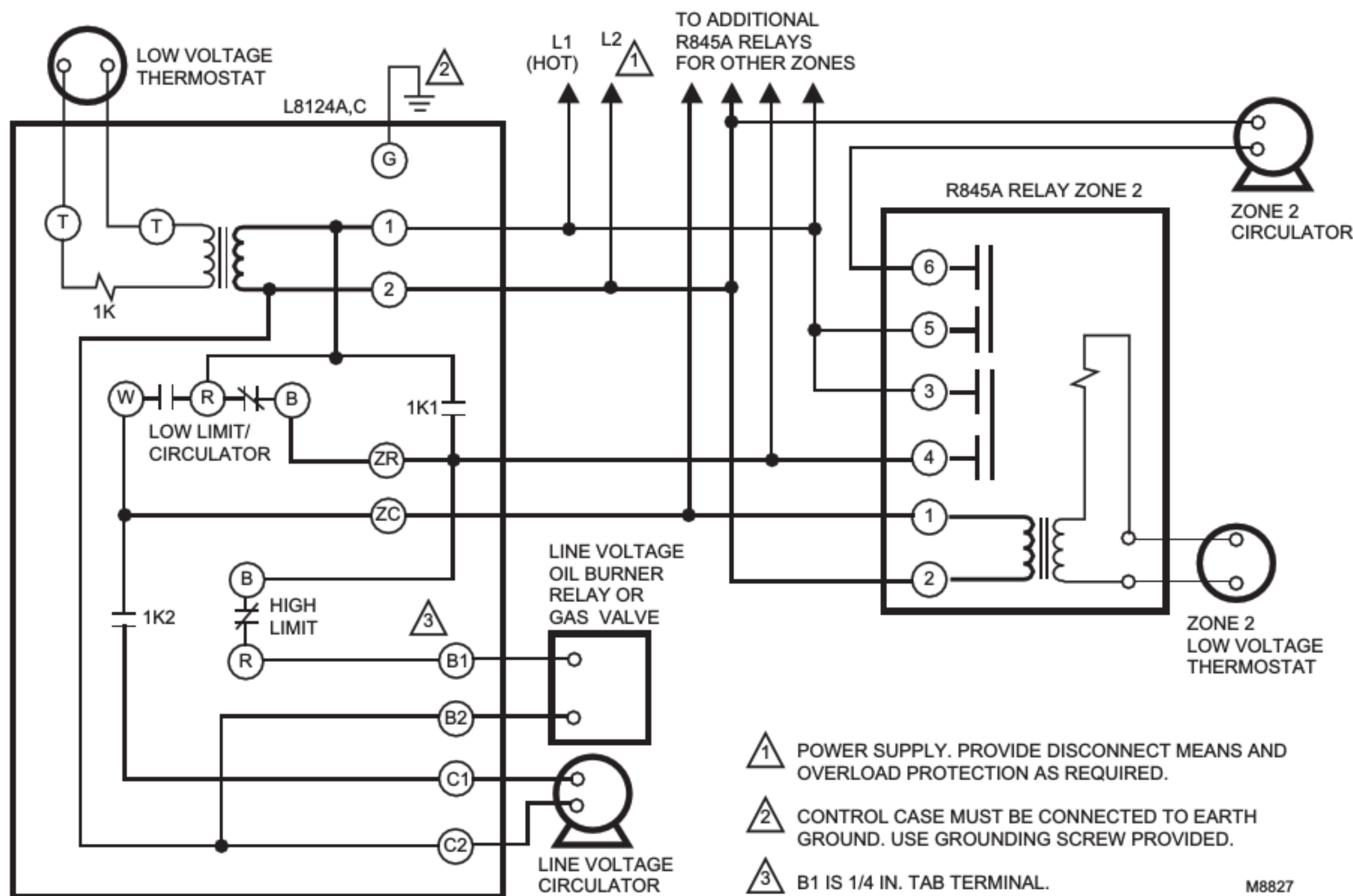

- ⚠️ 1 POWER SUPPLY. PROVIDE DISCONNECT MEANS AND OVERLOAD PROTECTION AS REQUIRED.
- ⚠️ 2 CONTROL CASE MUST BE CONNECTED TO EARTH GROUND. USE GROUNDING SCREW PROVIDED.
- ⚠️ 3 B1 IS 1/4 IN. TAB TERMINAL.

M8827

Fig. 6. L8124A,C multizone system with circulator connections and internal schematic.

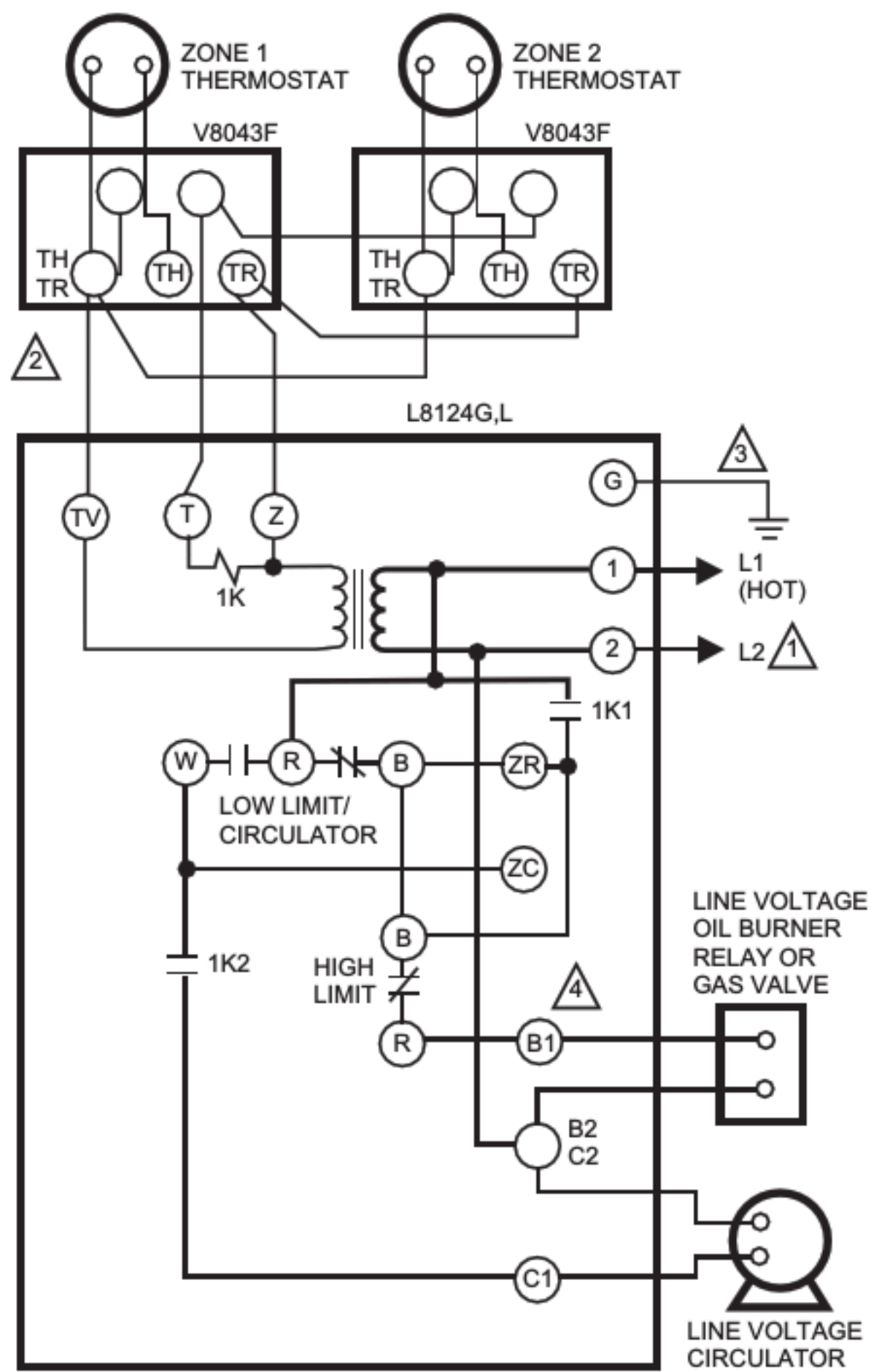

- 1 POWER SUPPLY. PROVIDE DISCONNECT MEANS AND OVERLOAD PROTECTION AS REQUIRED.
- 2 UP TO TWO V8043F ZONE VALVES CAN BE POWERED WITH L8124G,L. ADD ADDITIONAL TRANSFORMER FOR EVERY TWO OR LESS VALVES.
- 3 CONTROL CASE MUST BE CONNECTED TO EARTH GROUND. USE GROUNDING SCREW PROVIDED.
- 4 B1 IS 1/4 IN. TAB TERMINAL. M1795B

Fig. 7. L8124 multizone system with zone valve connections and internal schematic.

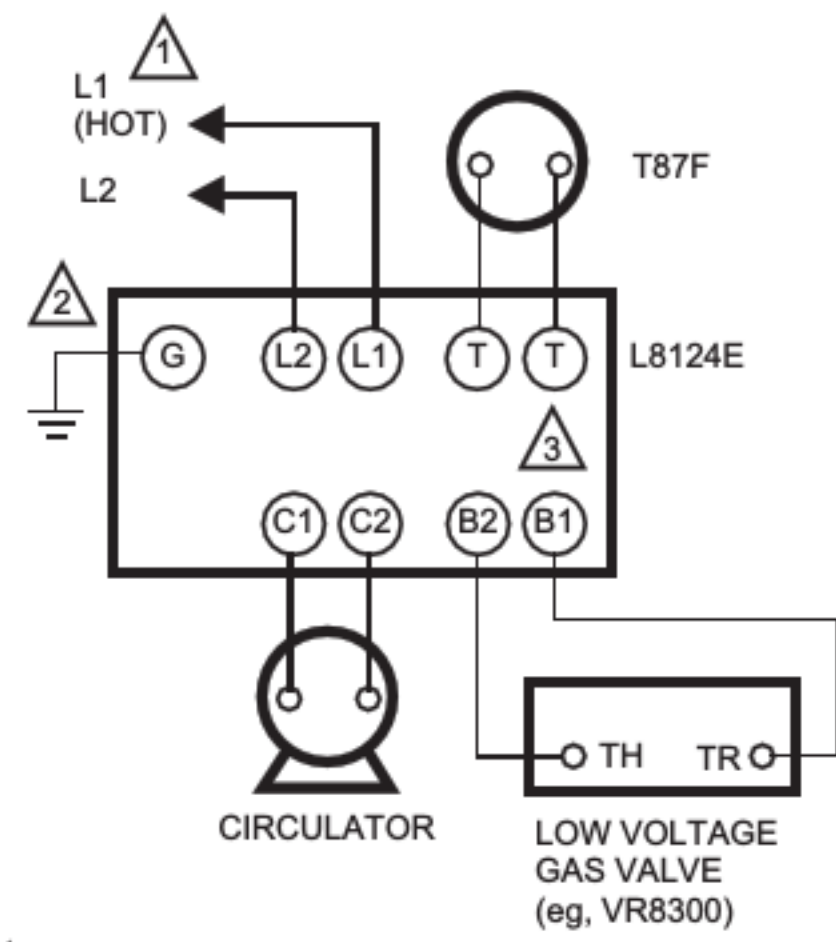

- 1 POWER SUPPLY. PROVIDE DISCONNECT MEANS AND OVERLOAD PROTECTION AS REQUIRED.
- 2 CONTROL CASE MUST BE CONNECTED TO EARTH GROUND. USE GROUNDING SCREW PROVIDED.
- 3 B1 IS 1/4 IN. TAB TERMINAL. M1796A

Fig. 8. L8124E in a 24Vac, gas-fired, forced hot water, tankless system.

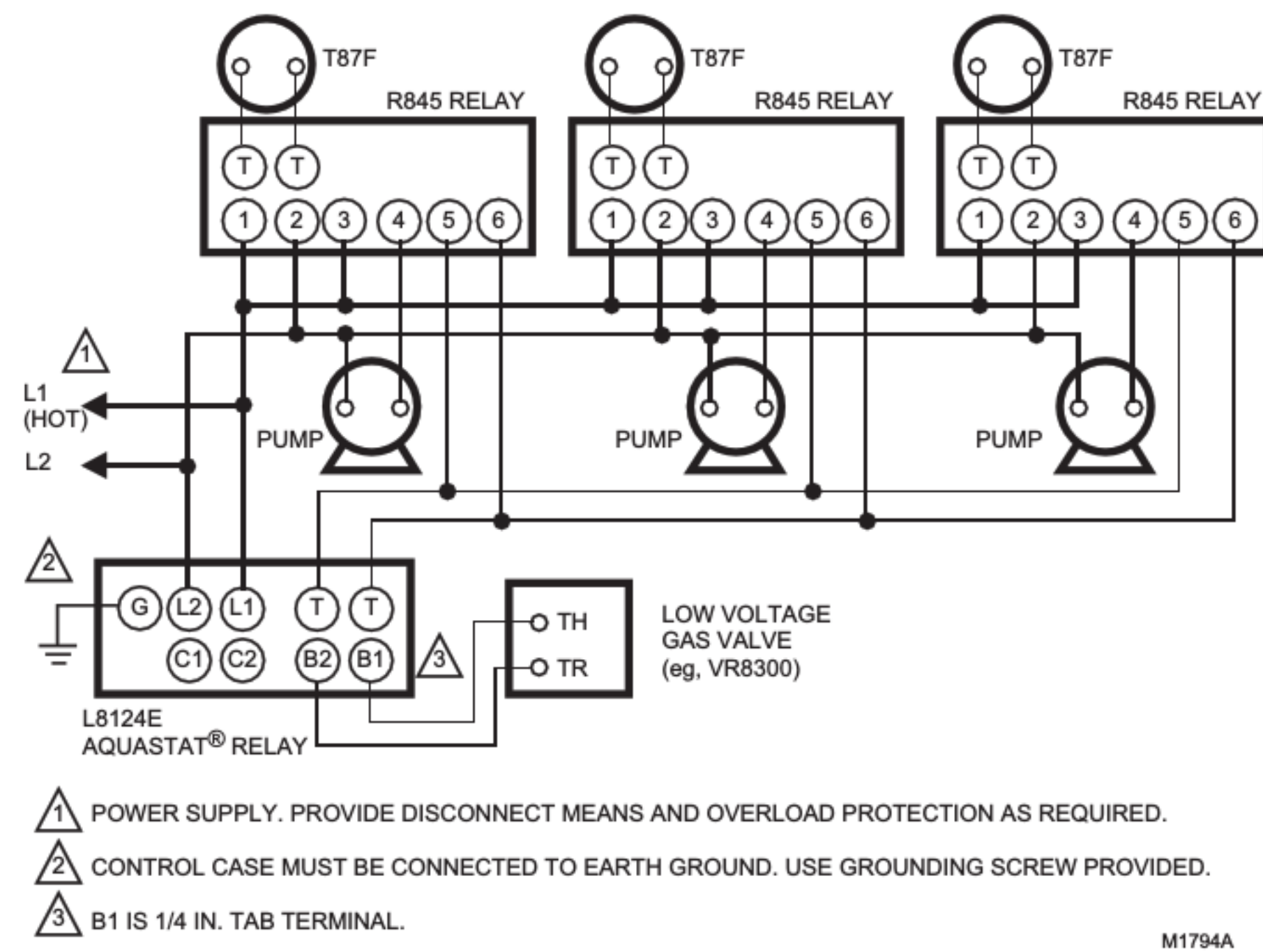

Fig. 9. L8124E in a 24 Vac, gas-fired, forced hot water, tankless, zoned pump system.

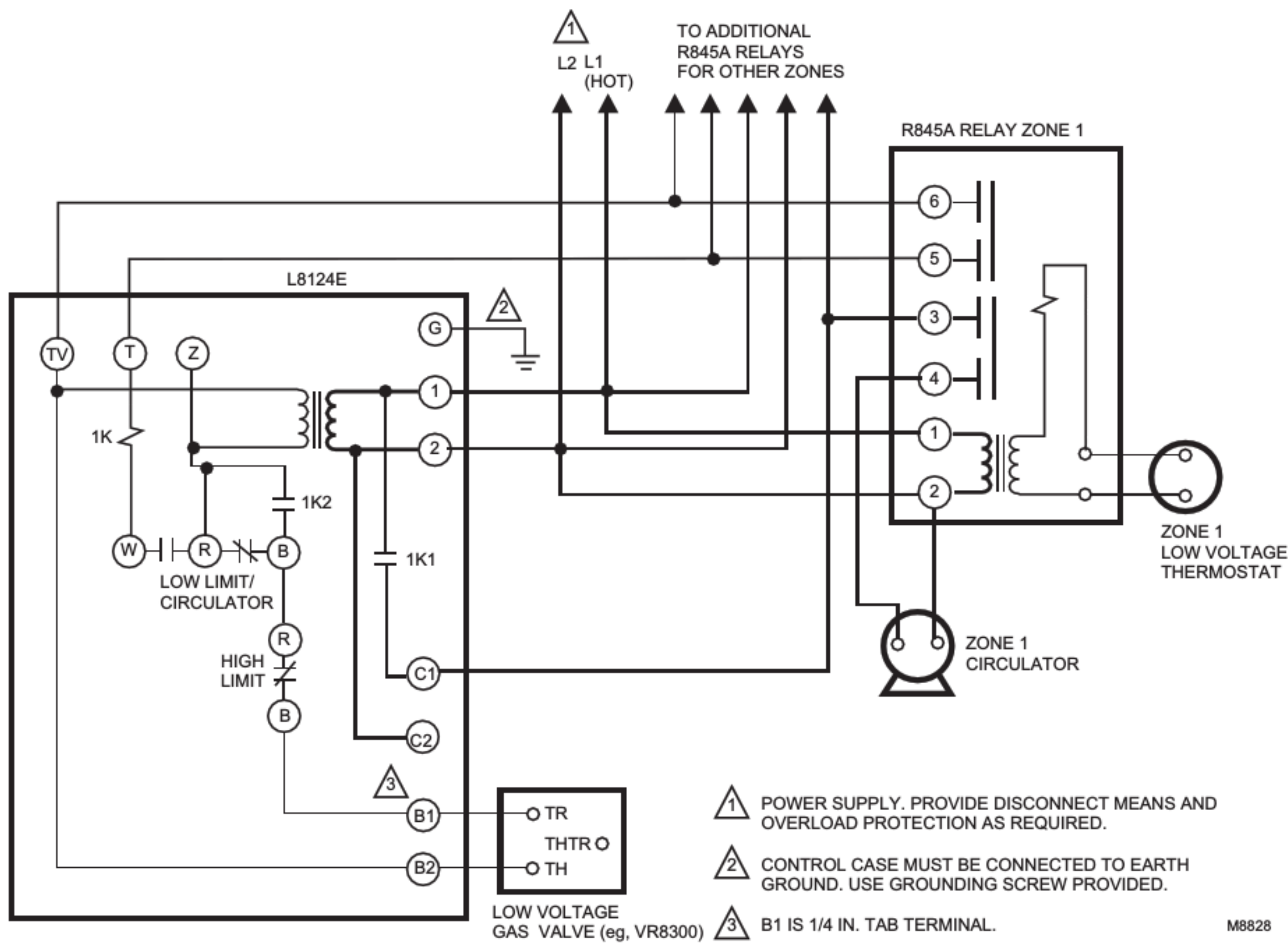

Fig. 10. L8124E multizone system with circulator connections and internal schematic.

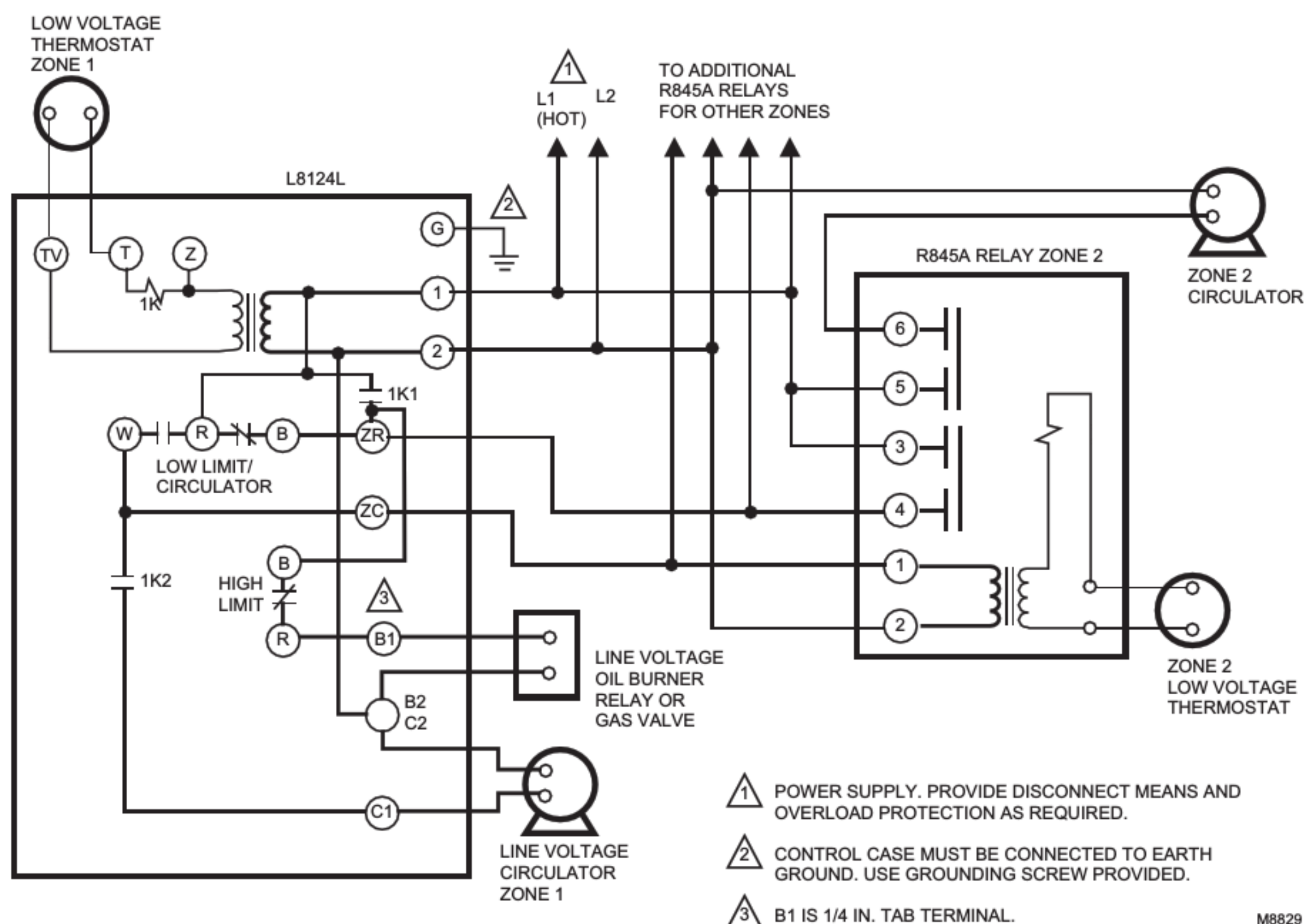

Fig. 11. L8124L multizone system with circulator connections and internal schematic.

OPERATION

High Limit Controller

The high limit opens and turns off the burner when the water temperature reaches the setpoint. The high limit automatically resets after the water temperature drops past the setpoint and through the 10°F (6°C) differential.

⚠ WARNING

Explosion Hazard.
Can cause serious injury, death or equipment damage.
Use this product only in systems with a pressure relief valve.

Low Limit and Circulator Controllers

On a temperature rise, with the adjustable differential at the minimum setting of 10°F (6°C), the burner circuit (R-B) breaks and the circulator circuit (R-W) makes at the control setpoint. On a temperature drop of 10°F (6°C) below the setpoint, the R-B circuit makes and the R-W circuit breaks. See Fig. 12.

At any differential setting greater than 10°F (6°C), the R-B make temperature and the R-W break temperature remain the same (control setting minus 10°F [6°C]). The R-B break and R-W make temperature are the setpoint temperature plus the difference between the differential setting and 10°F (6°C).

EXAMPLE: Setpoint of 140°F (60°C), differential set at 25°F (14°C). On a temperature rise, R-B breaks and R-W makes at 155°F (68°C). On a temperature fall, R-B makes and R-W breaks at 130°F (54°C).

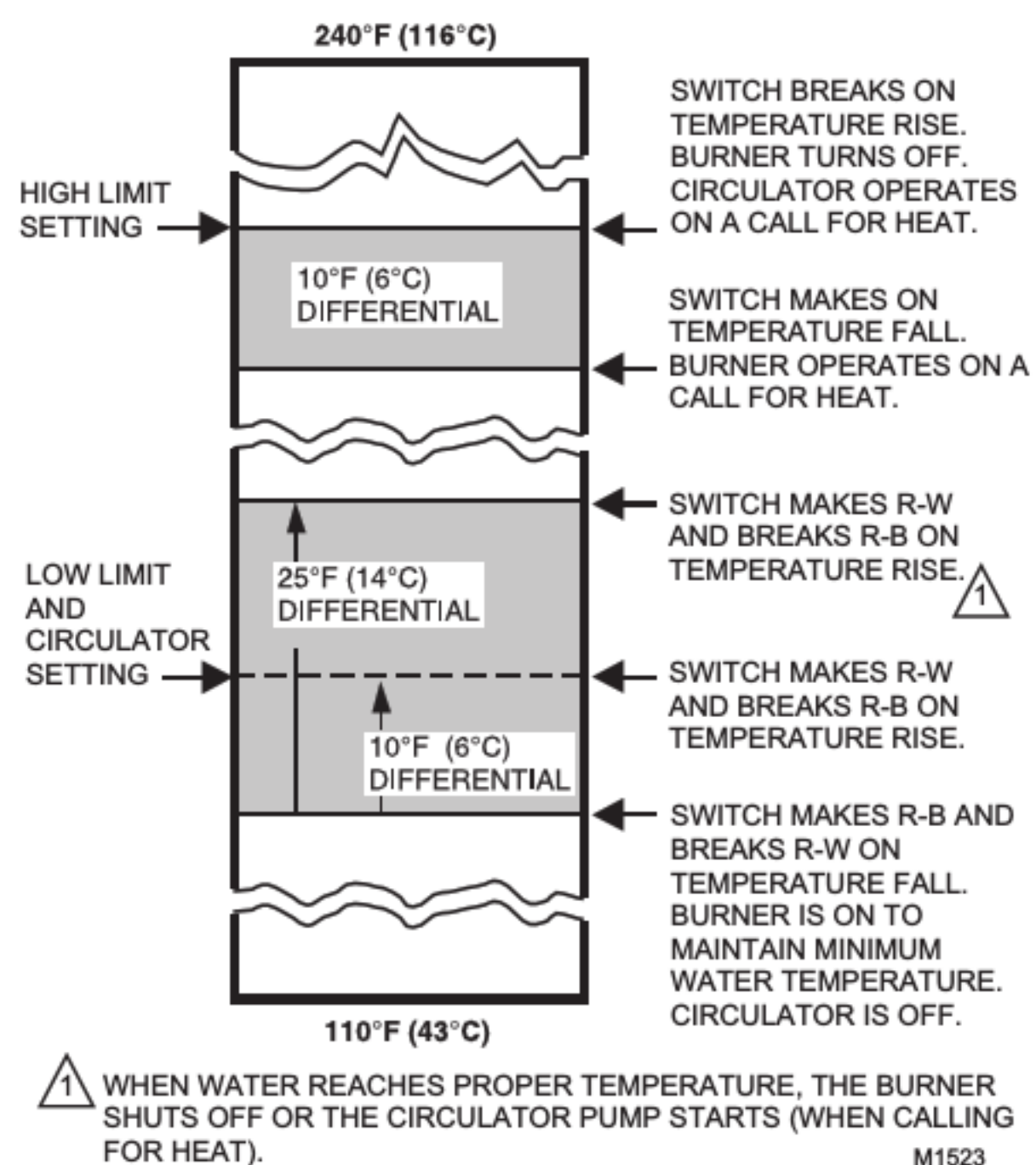

Fig. 12. Relationship of setpoints and differential.

On the L8124M, the burner and circulator circuits are separately controlled; the low limit controls the burner circuit (R-B) as described above, while the low voltage thermostat directly controls the circulator circuit. See Fig. 13.

SETTING

Follow the boiler manufacturer recommendations when making the L8124 settings. The high limit setting must be at least 20°F (11°C) higher than the low limit setting. Set the indicators over the selected temperature marks. The low limit differential is set by turning the differential adjustment knob to the desired amount of differential. The thermostat heat anticipator should be set at 2.0A.

CHECKOUT

Put the system into operation and observe each function through at least one complete cycle. Be sure the control operates as intended.

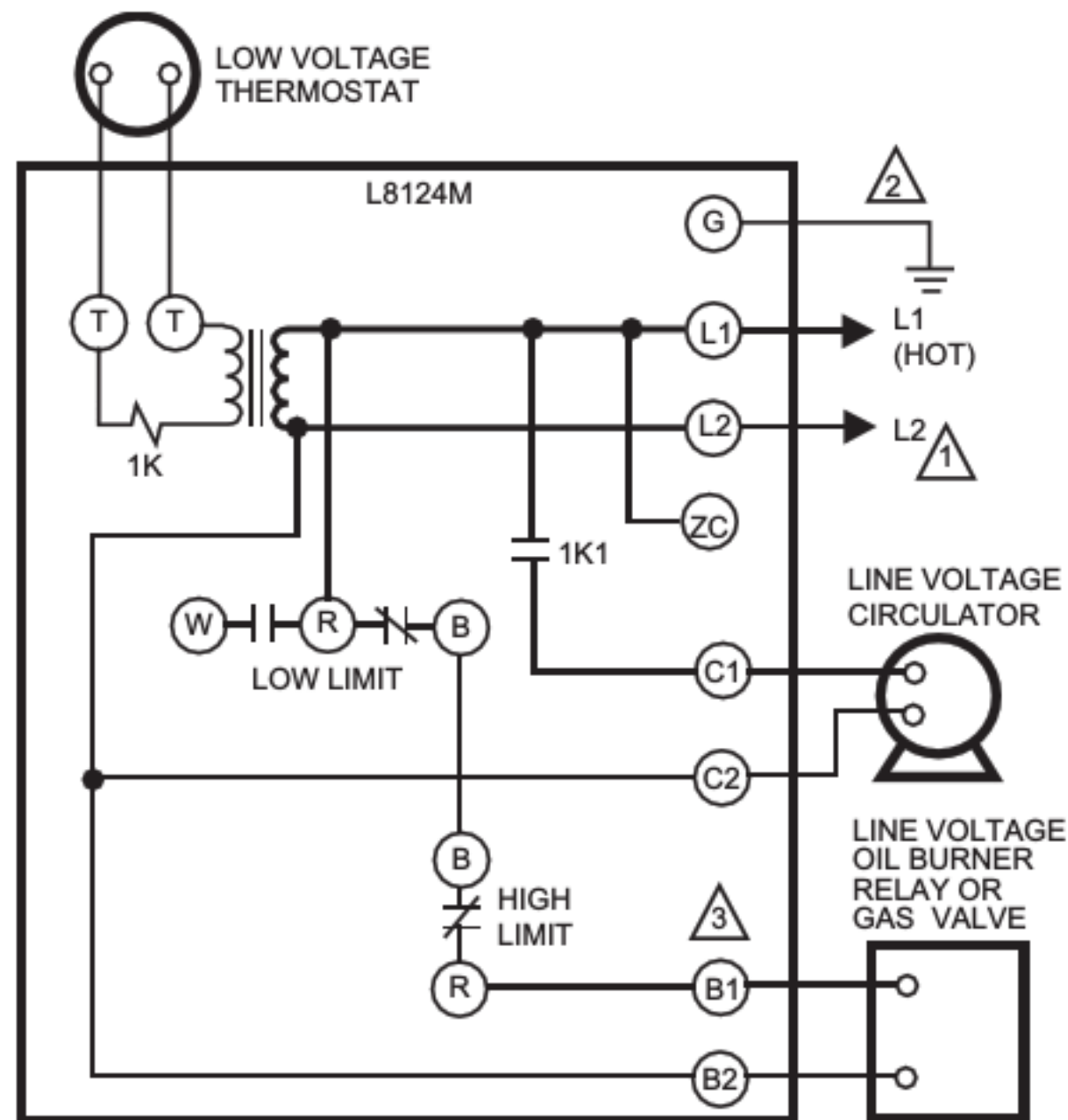

1 POWER SUPPLY. PROVIDE DISCONNECT MEANS AND OVERLOAD PROTECTION AS REQUIRED.

2 CONTROL CASE MUST BE CONNECTED TO EARTH GROUND. USE GROUNDING SCREW PROVIDED.

3 B1 IS 1/4 IN. TAB TERMINAL.

M8804

Fig. 13. L8124M single zone connections and internal schematic.

Honeywell

Automation and Control Solutions Automation and Control Solutions

Honeywell
1985 Douglas Drive North
Golden Valley, MN 55422

Honeywell Limited-Honeywell Limitée
35 Dynamic Drive
Scarborough, Ontario
M1V 4Z9