

T8611G,R Chronotherm III Fuel Saver Thermostats

Application

These thermostats provide energy saving control for a 24 Vac multistage heat pump heating/cooling system as indicated in Table 1 and are powered directly from the control transformer. All models have 5-1-1 programming.

As long as AC power is continuously available to transformer, the thermostat will be compatible with most control systems.

The T8611G,R models include SYSTEM and ENRG SAV LEDs near the top front of the thermostat. The SYSTEM LED lights when the thermostat is signaling for heating or air conditioning. The ENRG SAV LED lights during the LEAVE and SLEEP periods.

The AUX. HT., EM. HT., and CHECK LEDs are located near the bottom center of the subbase. See Table 1. The AUX. HT. LED lights whenever the thermostat is calling for operation of the backup or auxiliary heater. Backup (auxiliary) heat is more expensive to operate than the heat pump and typically is used only when the heat pump is unable to handle the load. The EM. HT. LED lights whenever the thermostat system switch is in the EM. HT. position. The CHECK LED lights when something needs to be checked to maintain efficient operation of the system. Consult heat pump equipment literature to determine specific meaning of this LED.

Heat and cool anticipation is fixed in all models; no adjustment is necessary. Cycle rates are adjustable for auxiliary heating stage.

TABLE 1—Thermostat Models.

Thermostat	Stages		Switching		LEDs	Changeover	Terminals	Comments	See Fig.
	Heat	Cool	System	Fan					
T8611G	2	1	EM.HEAT-HEAT-OFF-AUTO-COOL	ON-AUTO	EM.HT, AUX.HT.	Auto	R, C/X, L, W ₂ , E, G, O, B, Y, X ₂ , X ₁	—	4
T8611R	2	1	EM.HEAT-HEAT-OFF-COOL	ON-AUTO	EM.HT., AUX.HT.	Manual	R, C/X, L, W ₂ , E, W ₁ , G, O, B, Y, P	—	5
	2	1	EM.HEAT-HEAT-OFF-COOL	ON-AUTO	EM.HT.	Manual	R, B, X, W ₂ , E, W ₁ , G, O, H, Y ₁	Exact replacement for York model no. 2ET11700224.	6

Installation

WHEN INSTALLING THIS PRODUCT...

1. Read these instructions carefully. Failure to allow them could damage the product or cause a hazardous condition.
2. Check the ratings on the product to make sure the product is suitable for your application.
3. Installer must be a trained, experienced service technician.
4. Allow thermostat to warm to room temperature before operating.
5. After installation is complete, check out product operation as provided in these instructions.

CAUTION

1. Disconnect power supply to prevent electrical shock or equipment damage.
2. After wiring is complete, push excess wire back into the hole, and plug hole with nonhardening caulk, putty or insulation to prevent drafts from affecting thermostat operation.

LOCATION

Install thermostat and subbase about 5 ft. [1.5m] above the floor in an area with good air circulation at room temperature. Do not install the thermostat where it may be affected

by—

- drafts or dead spots behind doors, in corners or under cabinets.
- hot or cold air from ducts.
- radiant heat from sun or appliances
- concealed pipes and chimneys.
- unheated (uncooled) areas behind the thermostat, such as an outside wall.

IF REPLACING AN EXISTING THERMOSTAT

Turn off power to thermostat at furnace or heat pump. A two-transformer system may require turning off two switches or disconnects. Remove any existing wallplate or subbase from the wall. Label or write down each wire color with the letter or number on the wiring terminal as the wire is removed, to avoid miswiring later.

IF NEW INSTALLATION

Run a cable to a hole at the selected wall location, and pull about 3 in. [76 mm] of wire through the opening. Color-coded, 8-gauge thermostat cable with one conductor for each wiring terminal is recommended. Good service practice recommends selecting cable with one or two more conductors than the immediate application requires.

MOUNTING SUBBASE

The subbase does not require leveling for proper operation, but for appearance only.

Remove thermostat from subbase, see Fig. 1.

The subbase mounts directly onto the wall with the screws included in the package. Use the subbase as a template, and with a pencil, mark the two mounting screw positions, see Fig. 2. Use 3/16 in. bit to drill holes for anchors. Gently tap anchors into holes until they are flush with the wall surface. Thread wires through the center opening of the subbase. Then mount the subbase using two screws provided. Gently tighten screws level top surface of subbase, then securely tighten screws.

Fig. 1—Removing thermostat from subbase.

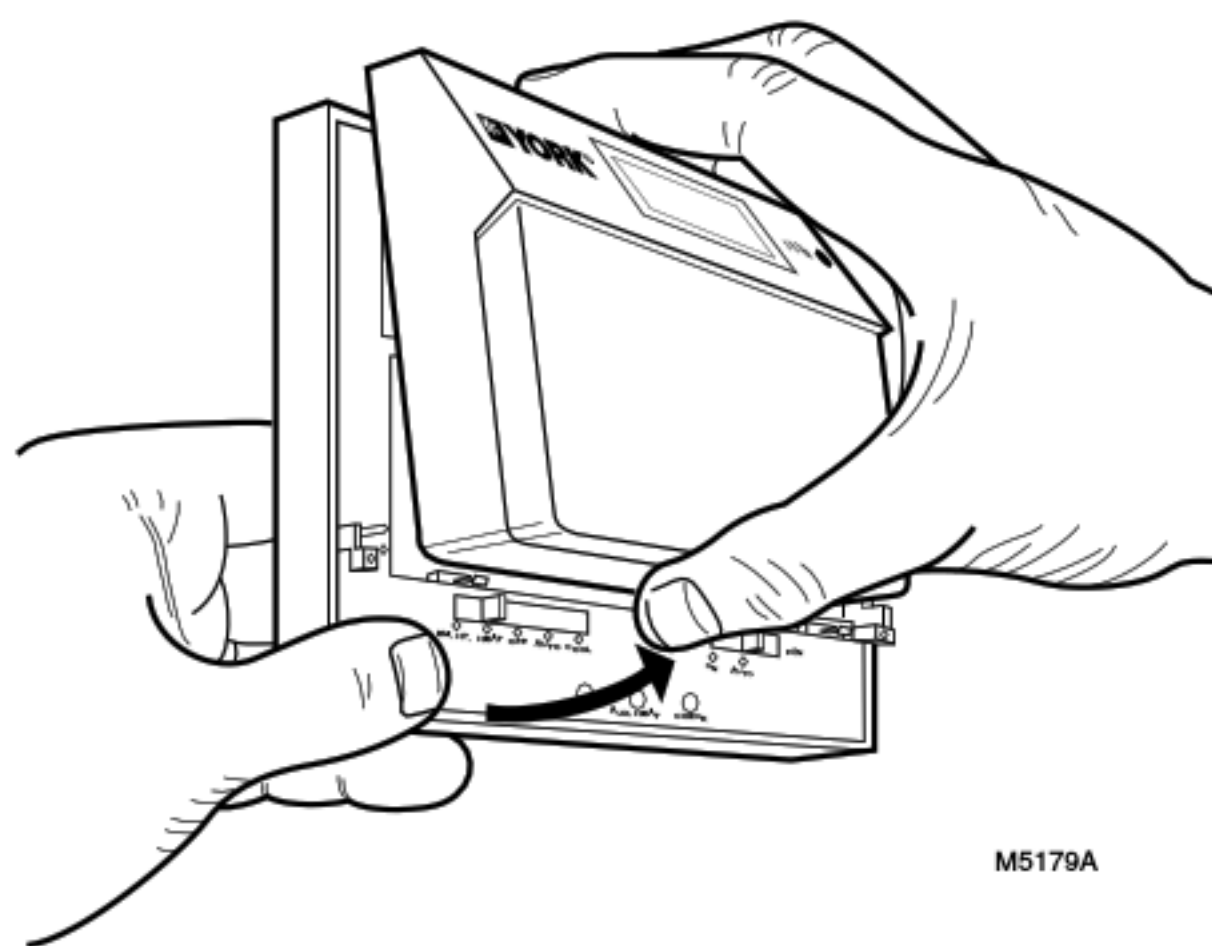
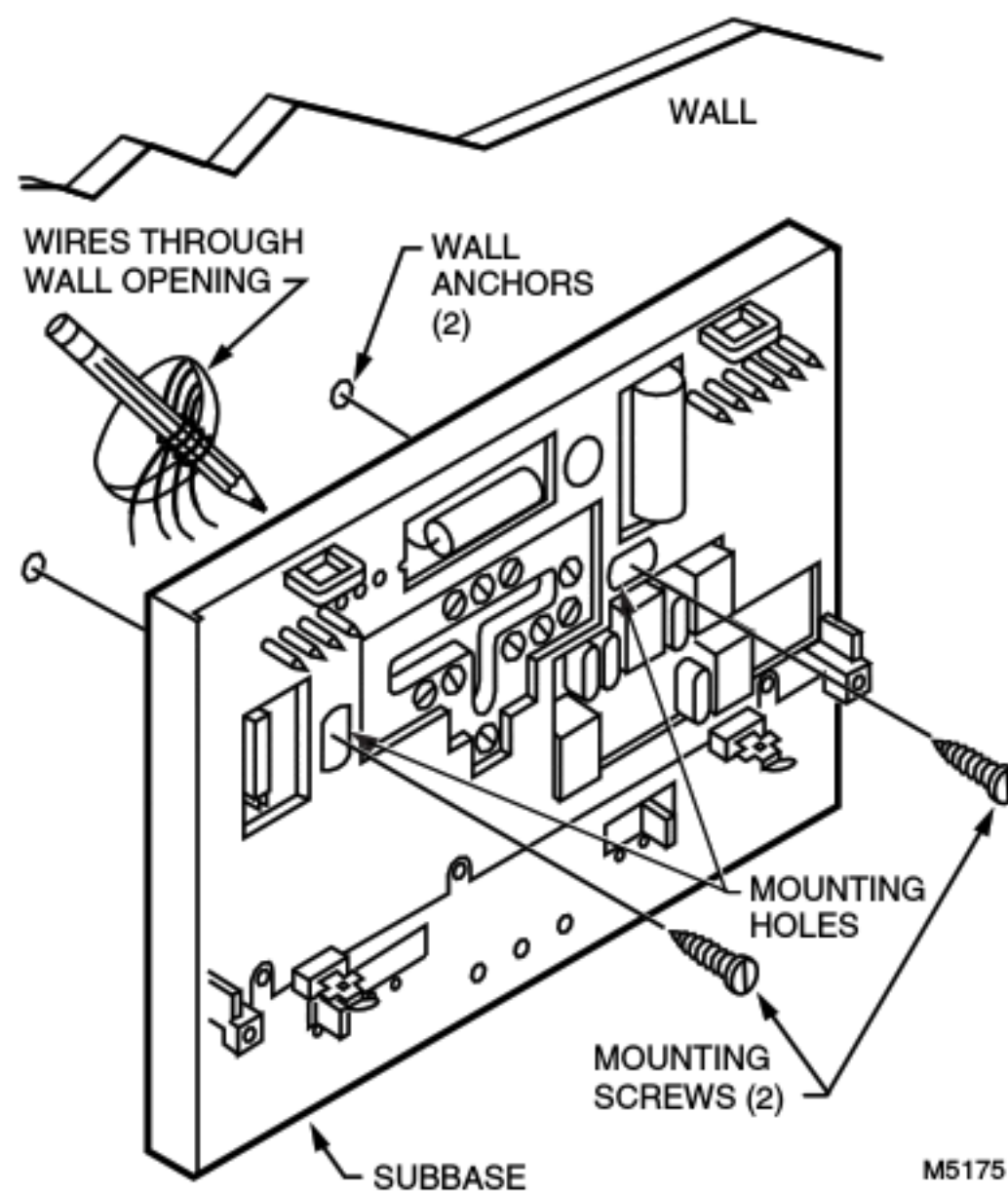

Fig. 2—Mounting subbase on wall.



WIRING

All wiring must comply with local electrical codes and ordinances.

Disconnect power before wiring to prevent electrical shock or equipment damage.

The shape of the terminal barrier permits insertion of straight or conventional wraparound wiring connections. Either method is acceptable.

Refer to Figs. 4-6 for typical hookups of subbase and thermostat.

NOTE: Keep all wiring restricted to ribbed area surrounding terminals to assure thermostat/subbase contact, see Fig. 3.

Fig. 3—Keep wiring restricted to ribbed area surrounding terminals.

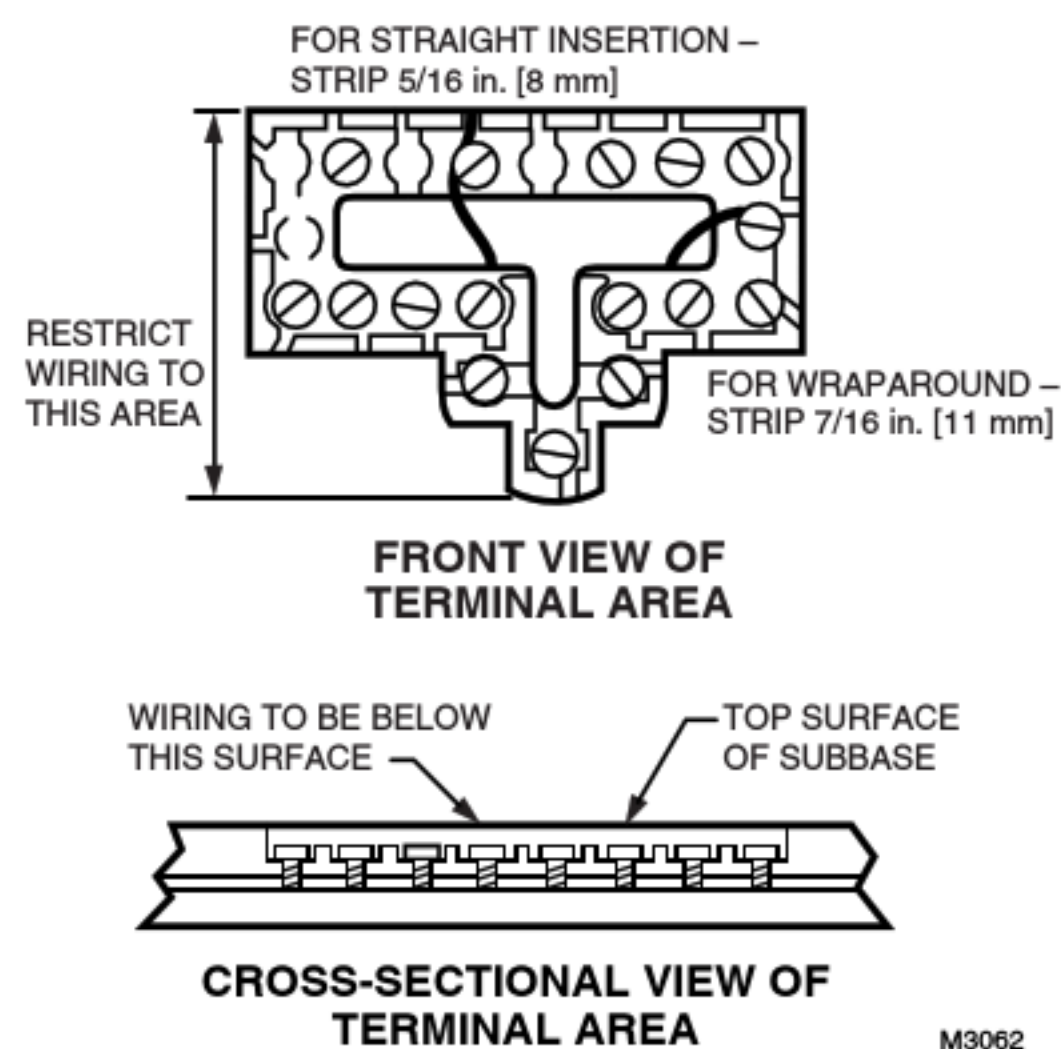
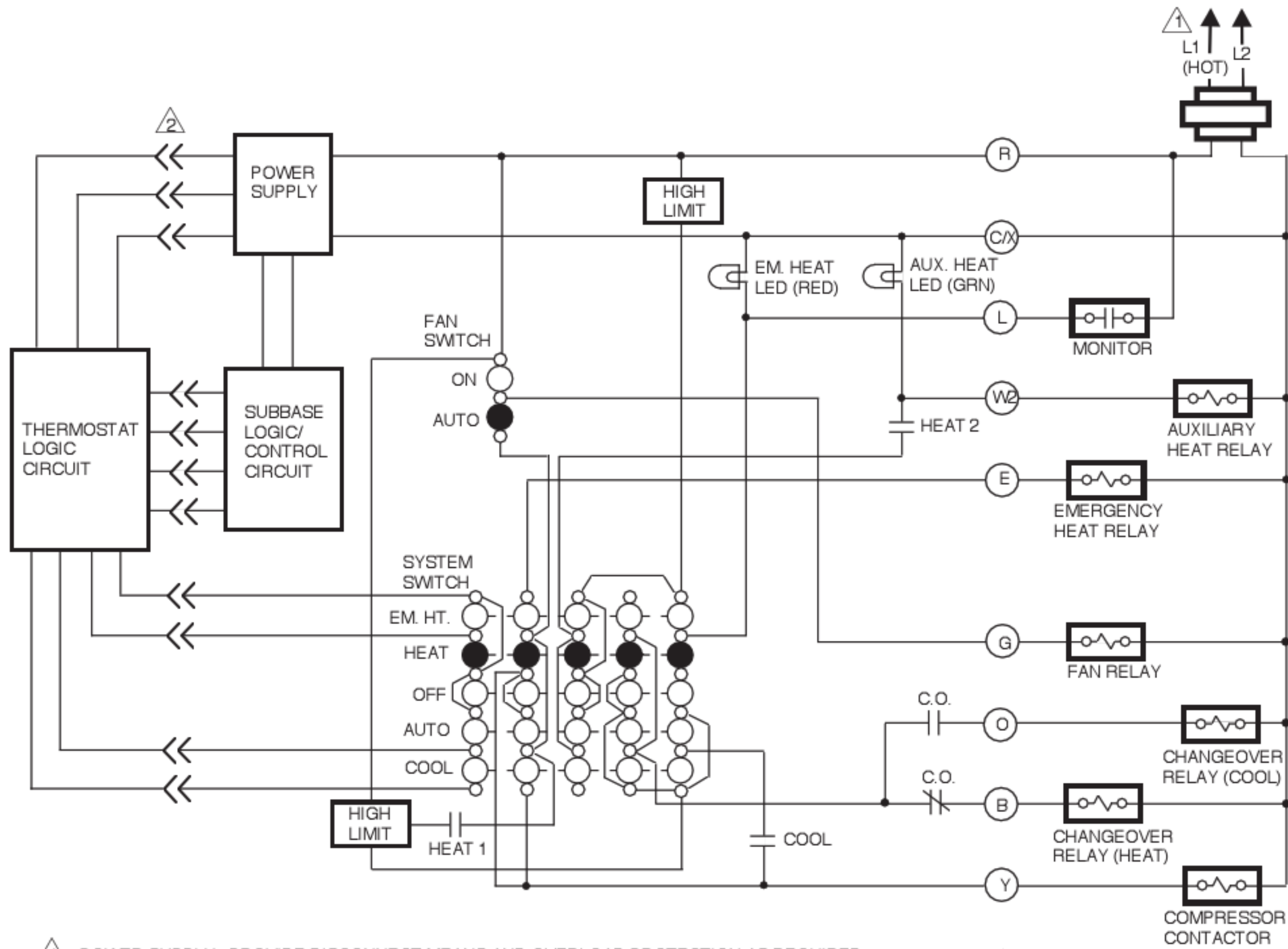

Fig. 4—T8611G 2-stage heat/1-stage cool thermostat.



① POWER SUPPLY. PROVIDE DISCONNECT MEANS AND OVERLOAD PROTECTION AS REQUIRED.

② —<<— DENOTES THERMOSTAT TO SUBBASE INTERCONNECT.

③ POSSIBLE CHECK LED CIRCUITS:

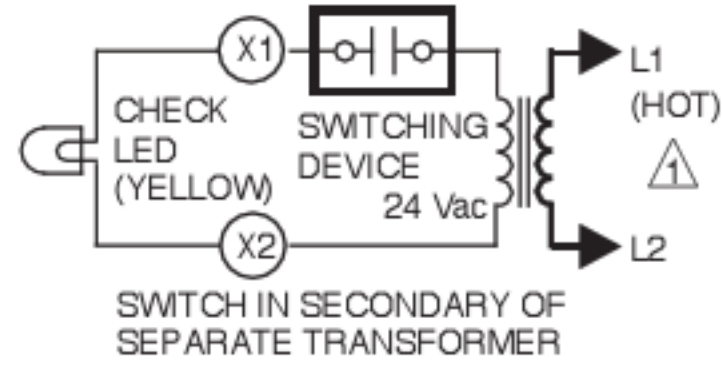
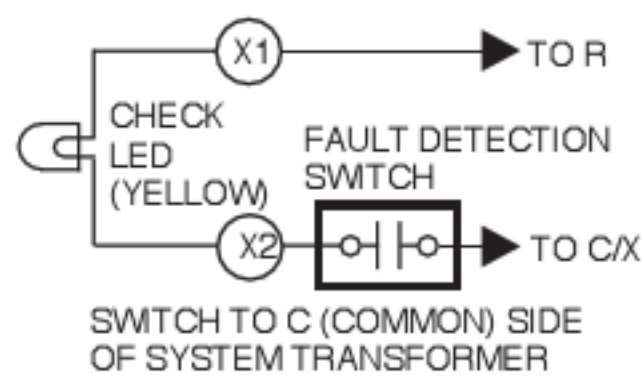
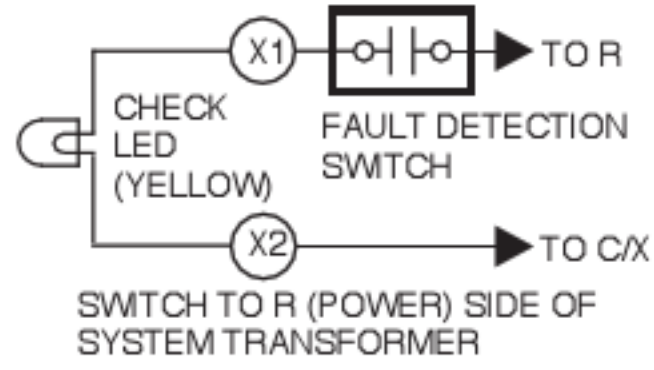
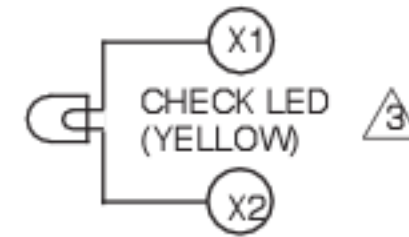

M 6020

Fig. 6—T8611R 2-stage heat/1-stage cool thermostat. Exact replacement for York model no. 2ET11700224.

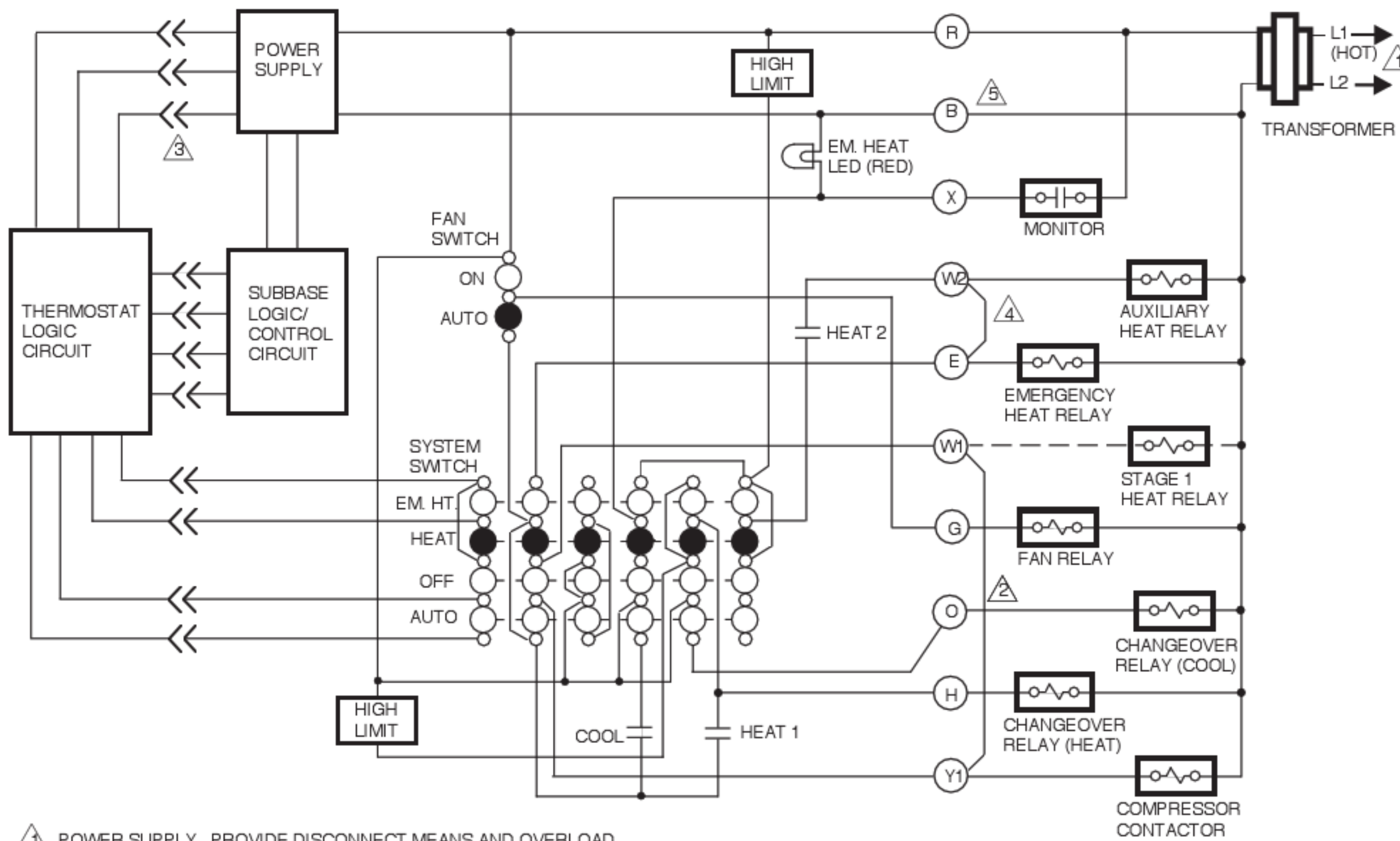

- ⚠️ 1 POWER SUPPLY. PROVIDE DISCONNECT MEANS AND OVERLOAD PROTECTION AS REQUIRED.
- ⚠️ 2 REMOVE JUMPER FOR SYSTEM WITH ISOLATED STAGE 1 HEATING AND COOLING CONNECTIONS.
- ⚠️ 3 —<<< DENOTES THERMOSTAT TO SUBBASE INTERCONNECT.
- ⚠️ 4 REMOVE JUMPER FOR SYSTEM WITH ISOLATED EMERGENCY HEAT.
- ⚠️ 5 TRANSFORMER COMMON IS CONNECTED TO B TERMINAL.

NOTE: THIS DIAGRAM IS FOR USE WHEN REPLACING ONLY YORK THERMOSTAT MODEL NO. 2ET11700224. USING THIS DRAWING FOR OTHER INSTALLATIONS CAN RESULT IN DAMAGE TO THERMOSTAT.

M3208

Fig. 7—Cycle rate adjustment.

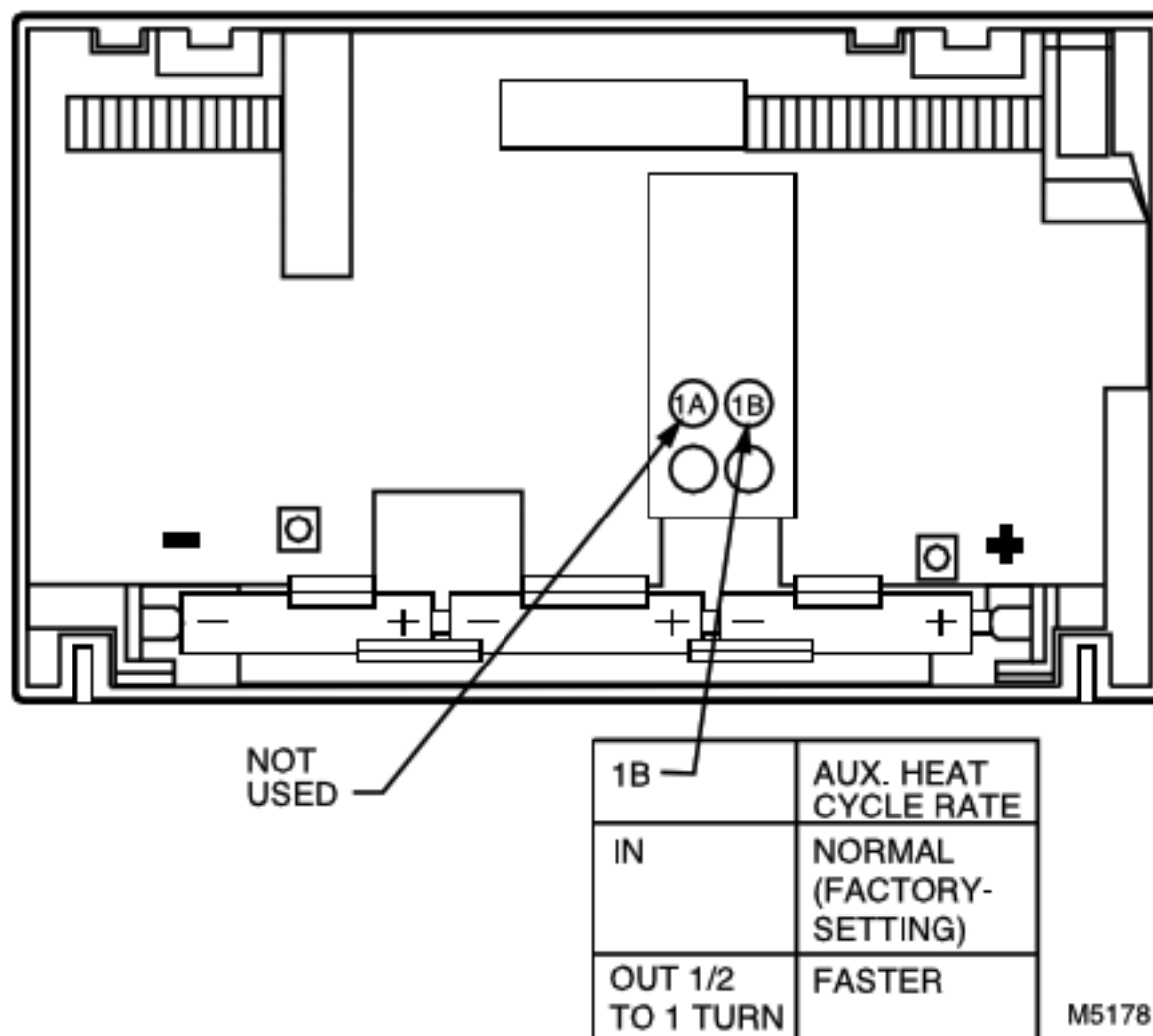

CYCLE RATE ADJUSTMENT

To custom-tailor the thermostat's cycling performance to different types of heating equipment, a cycle rate adjustment screw is provided on the back of the thermostat. Correct setting of this screw will provide optimum savings.

NOTE: Most applications will *not* require a change in cycle rate.

The room air temperature will normally vary slightly from the comfort temperature setting with the cycling of the heat pump or auxiliary heater.

Fig. 8—Battery placement.

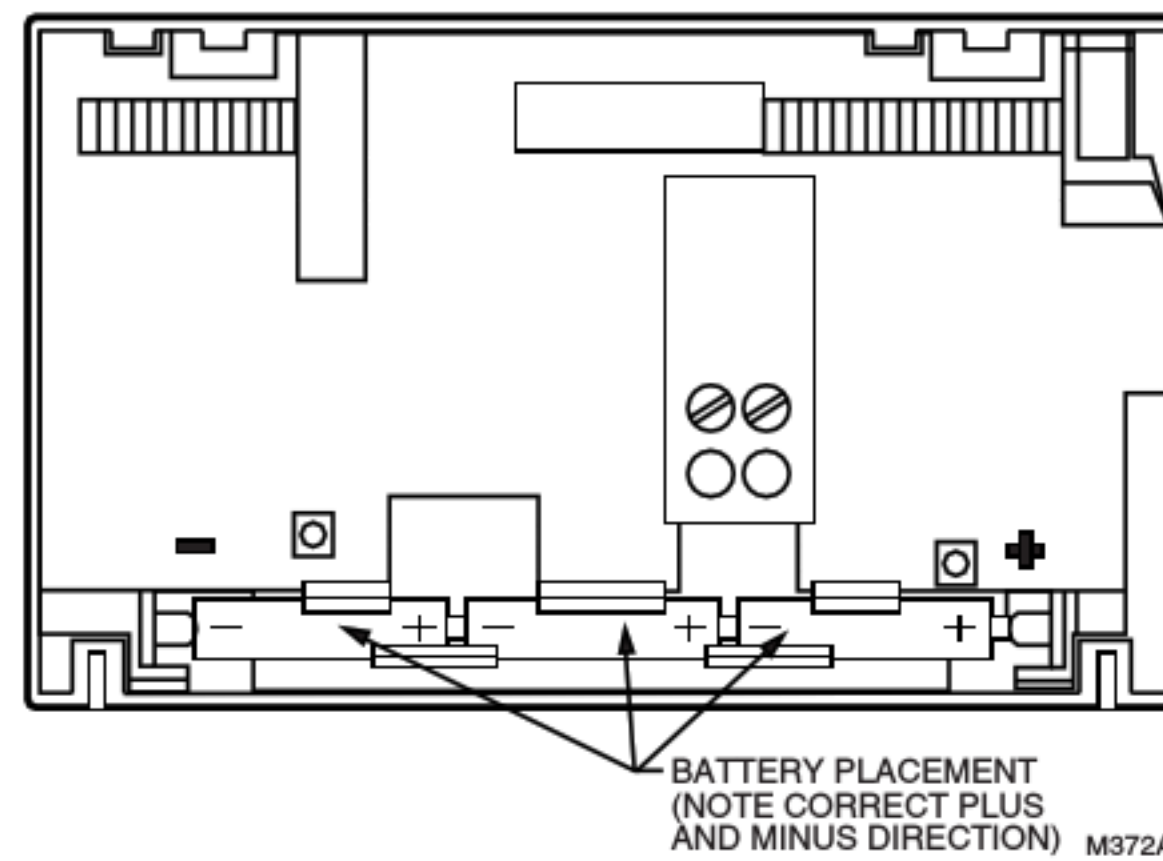

The cycle rate of this thermostat is factory-set for heat pumps. The heat pump compressor cycle rate can be adjusted by turning the cycle rate adjustment screw located on the back of the thermostat, see Fig. 7.

INSTALLING BATTERIES

Three AAA alkaline batteries are provided as backup to prevent program loss in event of power outage. Batteries are included with thermostat. Install batteries in back of thermostat as shown in Fig. 8.

Without battery backup, the program will remain about 20 seconds in event of power loss. When batteries are first installed, the display will flash 1:00 PM and 32°.

When the batteries are low, the display will flash REPL BAT. Homeowner will have 20-30 seconds to replace batteries after removing batteries from thermostat. After 20-30 seconds, it will be necessary to reprogram. REPL BAT indication will disappear when thermostat is mounted back on the powered subbase.

MOUNTING THE THERMOSTAT

With system switch set to OFF, hang the thermostat on the tabs at the top of the subbase (Fig. 9A). Swing down and press on lower edge until thermostat snaps in place (Fig. 9B). Open cover and tighten the captive mounting screws (Fig. 9C).

SETTING DAY AND TIME

Restore 24V power to the thermostat. When power is applied to the thermostat, the display will read 1:00 PM and room temperature. It will go off for a few seconds, then begin to flash on and off. Set present day and time.

Press 

Press  to set the current day. Each press of the DAY key advances the display one day.

Press TIME  or  to set the current time.

If the display will not come on.

- check mounting of thermostat to subbase. If loose or misaligned, remove thermostat and reinstall on the subbase, making sure it is firmly attached.
- check to see that system power is on.
- check voltage between R and C/X; it should be 20 to 30 Vac.

Checkout

CAUTION

During cold weather, some heat pumps will require that crankcase heater be energized several hours before operating heat pump. Refer to manufacturer's recommendations.

HEATING

When heating setting is changed, thermostat will wait up to 5 minutes before turning on the heating equipment. This delay protects the compressor.

Move the system switch to HEAT and the fan switch to AUTO. Press WARMER key until the setting is about 10° F [6° C] above room temperature. Heating should start and the fan should run (there may be a delay of 5-10 minutes before heat turns on). Press COOLER key until the setting is about 10° F [6° C] below room temperature. The heating equipment and fan should shut off.

NOTE: On an AUTO changeover thermostat, the cooling temperature must be set at least 3° F [1.7° C] above the heating temperature, or display will flash.

COOLING

CAUTION

Do not operate cooling if outdoor temperature is below 50° F [10° C]. Refer to manufacturer's recommendations.

Fig. 9—Mounting the thermostat on subbase.

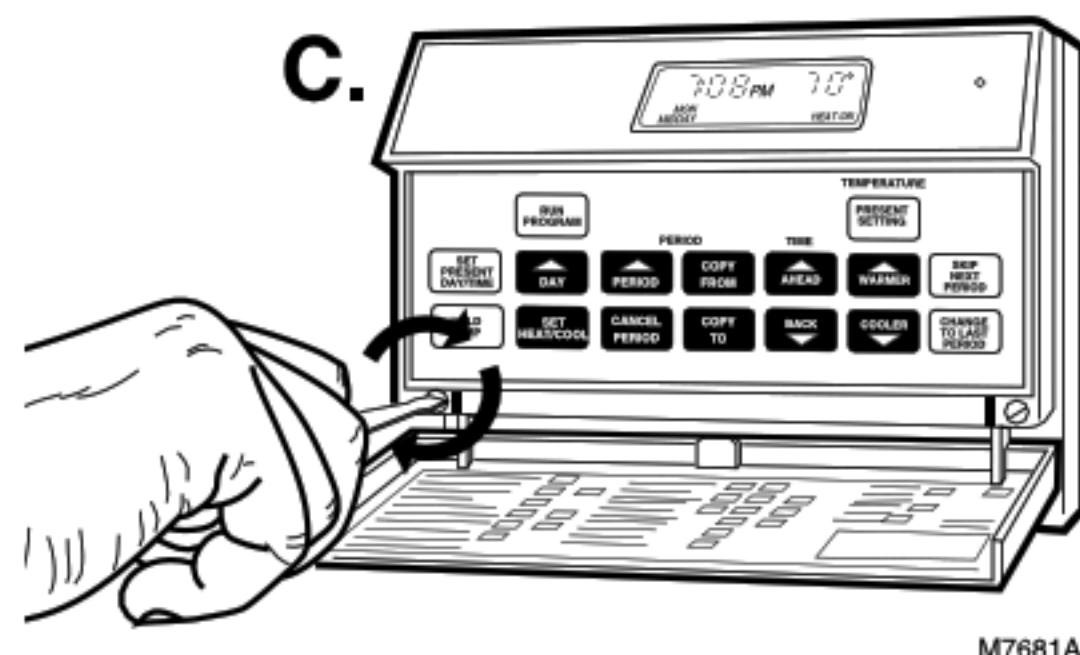
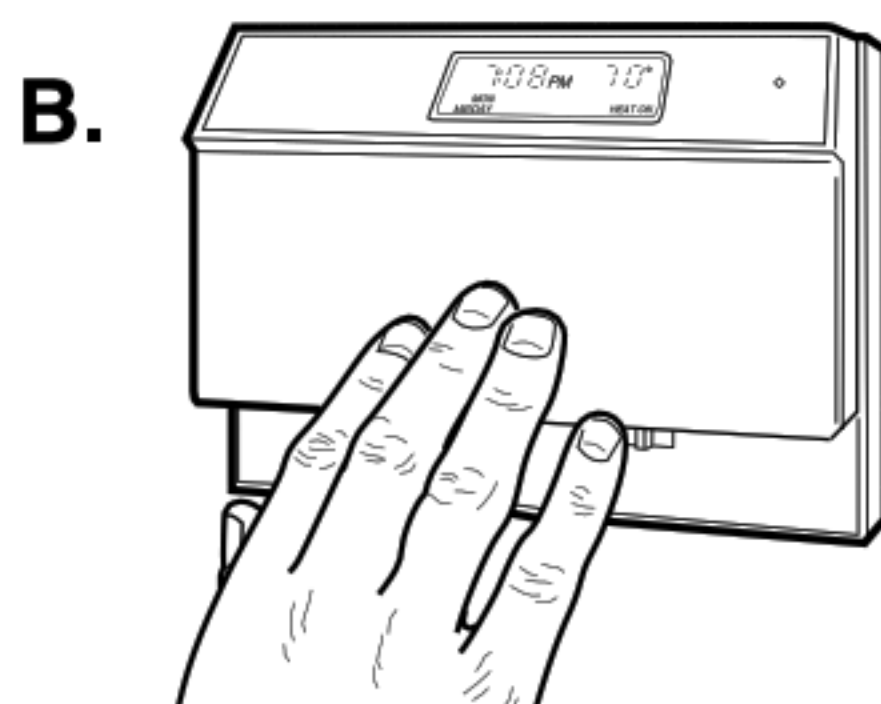
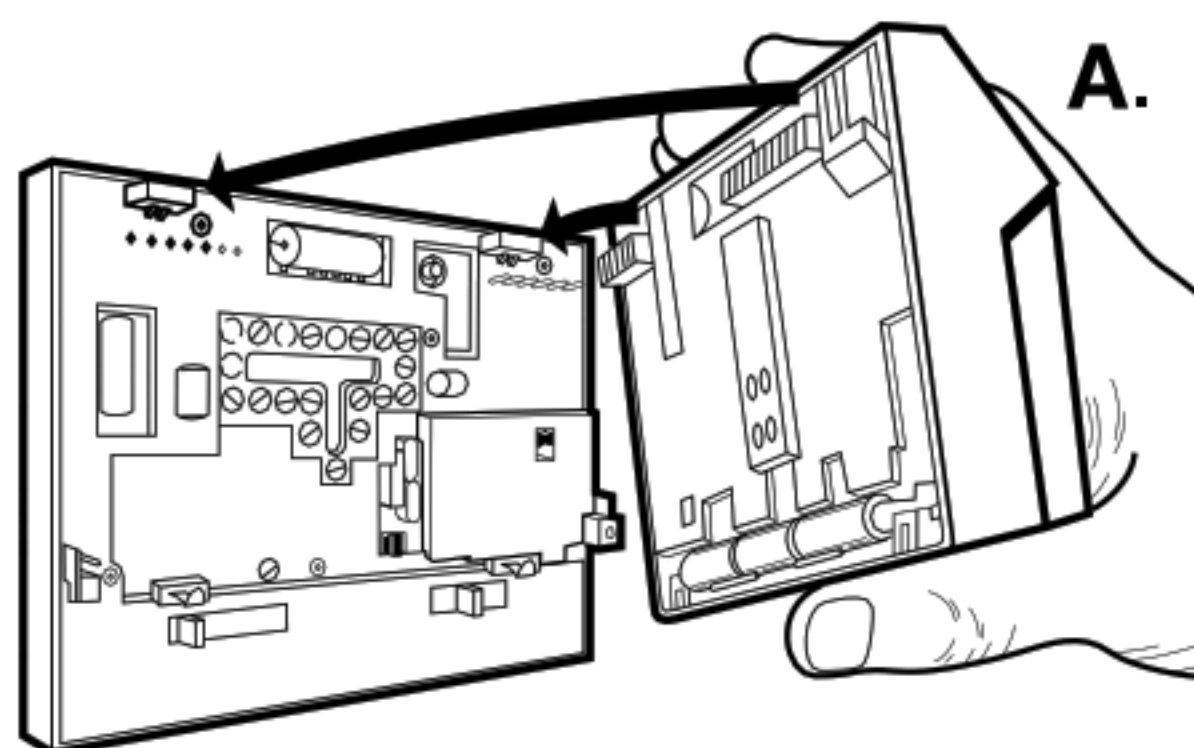

M7681A

NOTE: When cooling setting is changed, thermostat will wait up to 5 minutes before turning on the cooling equipment. This delay protects the compressor.

Move the system switch to COOL and the fan switch to AUTO. Press COOLER key until the setting is about 10° F [6° C] below room temperature. The cooling equipment and fan should start. Press WARMER key until the setting is about 10° F [6° C] above room temperature. The cooling equipment and fan should stop.

NOTE: On an AUTO changeover thermostat, the heating temperature must be set at least 3° F [1.7° C] below the cooling temperature, or display will flash.

FAN

Move the system switch to OFF, and the fan switch to ON. The fan should run continuously. When the fan switch is in the AUTO position, fan cycles with the heating or cooling system.

INSTALLER SELF-TEST (OPTIONAL)

NOTE: Thermostat must have AC power to perform self-test.

Perform the following test as a check of all thermostat functions. If thermostat does not respond as indicated, thermostat must be replaced.

1. Press AHEAD and BACK keys at the same time. While holding keys down, all segments of the display should be on, see Fig. 10.

2. Set system switch to OFF. Press AHEAD and BACK and PRESENT SETTING keys at the same time to enter self-test.

3. Press each key as listed below, and look for response listed, as key is held down and released.

Fig. 10—All segments on display.

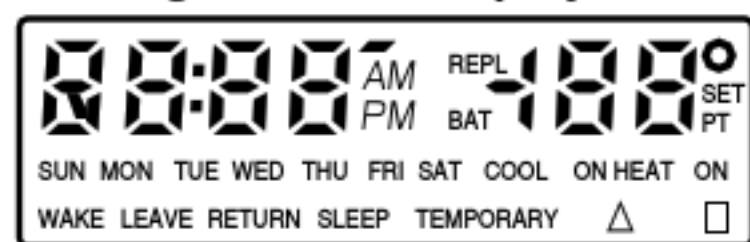

M410C

System Switch Position	Press This Key	Look for this Response	
		Key Down	Key Released
OFF	CHANGE TO LAST PERIOD	03	Blank
	SKIP NEXT PERIOD	07	Blank
	PRESENT SETTING	15	Blank
COOL or AUTO (with fan in AUTO)	PRESENT SETTING	15	Cooling, fan and SYSTEM LED on.
	PRESENT SETTING	15	Cooling, fan and SYSTEM LED off.
OFF	WARMER	06	Blank
	COOLER	02	Blank
	AHEAD	05	Blank
	BACK	04	Blank
	LEAVE	01	Blank
	RETURN	00	Blank
(CHECK EACH POSITION)	WAKE	12	See note (A)
OFF	SLEEP	08	Blank
	DAY	13	Microprocessor mask no. and revision no.
	SET HEAT/COOL	09	Blank
	SET PRESENT DAY/TIME	14	Blank
HEAT or AUTO (with fan in AUTO)	SET PRESENT DAY/TIME	14	1st stage heating, fan and SYSTEM LED on.
	SET PRESENT DAY/TIME	14	2nd stage heating and AUX. HEAT LED also on.
	SET PRESENT DAY/TIME	14	2nd stage heating and AUX. HEAT LED off.
	SET PRESENT DAY/TIME	14	1st stage heating, fan and SYSTEM LED off.
OFF	HOLD TEMP	10	Blank
	RUN PROGRAM	11	Normal operating display.

END SELF-TEST

(A) HEAT displayed when system switch is in HEAT, COOL when in COOL, HEAT or COOL when in AUTO, neither when in OFF. Also, a four-digit code is displayed, with each digit explained on the next page.

4-DIGIT CODE EXPLANATION

First Digit	Cycle Rate Setting (CPH at 50% on time, 2nd stage heat)
0 or 2	6
4 or 6	3

Second Digit	Clock (Hrs.)	Degrees
0	12	F
1	12	C
4	24	F
5	24	C

6002

M 524

Third Digit	System Switch Position
0	HEAT, EM.HT, or OFF
2	AUTO
4	COOL

Fourth Digit	Thermostat Type No.	System Switch Position
0	R	COOL, OFF
1	G	COOL, AUTO or OFF
2	R	EM.HT. or HEAT
3	G	AUTO, EM.HT. or HEAT

Refer to Owner's Manual for programming instructions and homeowner troubleshooting.

This equipment is a Class B digital apparatus which complies with Canadian Radio Interference Regulations, CRCc. 1374.

Honeywell

Home and Building Control
Honeywell Inc.
1985 Douglas Drive North
Golden Valley, Minnesota 55422

Home and Building Control
Honeywell Limited—Honeywell Limitée
740 Ellesmere Road
Scarborough, Ontario
M1P 2V9

Helping You Control Your World



Printed in TAIWAN, R.O.C.