

## **HercuLine<sup>®</sup> 2000 Series Actuator Installation, Operation and Maintenance Manual**

Doc. No.: 62-86-25-10  
Revision: 7  
Date: 7/08

# Notices and Trademarks

Copyright 2008 by Honeywell  
Revision 7 July 2008

## Warranty/Remedy

Honeywell warrants goods of its manufacture as being free of defective materials and faulty workmanship. Contact your local sales office for warranty information. If warranted goods are returned to Honeywell during the period of coverage, Honeywell will repair or replace without charge those items it finds defective. The foregoing is Buyer's sole remedy and is in lieu of all other warranties, expressed or implied, including those of merchantability and fitness for a particular purpose. Specifications may change without notice. The information we supply is believed to be accurate and reliable as of this printing. However, we assume no responsibility for its use.

While we provide application assistance personally, through our literature and the Honeywell web site, it is up to the customer to determine the suitability of the product in the application.

## CE Conformity

This product conforms with the protection requirements of the following European Council Directive: 89/336/EEC, the EMC directive and 73/23/EEC, the Low Voltage Directive. Conformance of this product with any other "CE Mark" Directive(s) shall not be assumed.

## Attention

The emission limits of EN 50081-2 are designed to provide reasonable protection against harmful interference when this equipment is operated in an industrial environment. Operation of this equipment in a residential area may cause harmful interference. This equipment generates, uses, and can radiate radio frequency energy and may cause interference to radio and television reception when the equipment is used closer than 30 m to the antenna(e). In special cases, when highly susceptible apparatus is used in close proximity, the user may have to employ additional mitigating measures to further reduce the electromagnetic emissions of this equipment.

## Honeywell Process Solutions

512 Virginia Drive  
Fort Washington, PA 19034

HercuLink® and HercuLine® are trademarks of Honeywell  
Palm is a trademark of Palm Inc.  
Other brand or product names are trademarks of their respective owners.

# About This Document

## Abstract

This manual describes the installation, set up, operation, maintenance, and troubleshooting of the HercuLine 2000 series actuators.

## References

The following list identifies all documents that may be sources of reference for material discussed in this publication.

Document Title	Doc ID
HercuLine 2000 Series Actuator Specification	61-86-03-14
HercuLine 2000 Series Actuator Model Selection Guide	62-86-16-21
Modbus® RTU Serial Communications User Manual	51-52-25-66
Modbus® RTU Serial Communications User Manual Configuration/Remote Calibration Interfaces for HercuLine Actuators	51-52-25-103
HercuLink™ User Manual	62-86-25-11
HART Communications Installation and Operations Manual	62-86-25-12

## Contacts

### World Wide Web

The following lists Honeywell's World Wide Web sites that will be of interest to our customers.

Honeywell Organization	WWW Address (URL)
Corporate	<a href="http://www.honeywell.com">http://www.honeywell.com</a>
Honeywell Process Solutions	<a href="http://www.honeywell.com/ps">http://www.honeywell.com/ps</a>











### Telephone

Contact us by telephone at the numbers listed below.

Organization	Phone Number
United States and Canada      Honeywell	1-800-423-9883      Tech. Support 1-800-525-7439      Service

# Symbol Definitions

The following table lists those symbols that may be used in this document to denote certain conditions.

Symbol	Definition
	This <b>DANGER</b> symbol indicates an imminently hazardous situation, which, if not avoided, <b>will result in death or serious injury</b> .
	This <b>WARNING</b> symbol indicates a potentially hazardous situation, which, if not avoided, <b>could result in death or serious injury</b> .
	This <b>CAUTION</b> symbol may be present on Control Product instrumentation and literature. If present on a product, the user must consult the appropriate part of the accompanying product literature for more information.
	This <b>CAUTION</b> symbol indicates a potentially hazardous situation, which, if not avoided, <b>may result in property damage</b> .
	<b>WARNING</b> <b>PERSONAL INJURY:</b> Risk of electrical shock. This symbol warns the user of a potential shock hazard where HAZARDOUS LIVE voltages greater than 30 Vrms, 42.4 Vpeak, or 60 Vdc may be accessible. <b>Failure to comply with these instructions could result in death or serious injury.</b>
	ATTENTION, Electrostatic Discharge (ESD) hazards. Observe precautions for handling electrostatic sensitive devices
	Protective Earth (PE) terminal. Provided for connection of the protective earth (green or green/yellow) supply system conductor.
	Functional earth terminal. Used for non-safety purposes such as noise immunity improvement. NOTE: This connection shall be bonded to protective earth at the source of supply in accordance with national local electrical code requirements.
	Earth Ground. Functional earth connection. NOTE: This connection shall be bonded to Protective earth at the source of supply in accordance with national and local electrical code requirements.
	Chassis Ground. Identifies a connection to the chassis or frame of the equipment shall be bonded to Protective Earth at the source of supply in accordance with national and local electrical code requirements.

# Contents

Introduction .....	1
Product Description .....	1
Specifications .....	5
Technical and Operating Specifications .....	5
Model Selection Guide .....	10
Installation .....	12
Installation Overview .....	12
Mechanical Stops .....	12
Before Starting.....	13
Actuator Mounting .....	13
Mechanical Installation .....	15
Electrical Installation.....	17
Burner Control/Flame Safety.....	23
Series 90 Control – HercuLine® 2001 model only.....	24
Split Range.....	26
Master/Slave Arrangement.....	26
Set Up and Calibration Procedures .....	31
Overview.....	31
Local Display and Keypad.....	31
Set Up Tips.....	33
Set Up Groups.....	34
Set Up Procedure .....	36
Configuration Prompt Hierarchy .....	38
Input Set Up Group.....	39
Relays Set Up Group.....	44
Current Out Set Up Group.....	49
Communications Set Up Group.....	50
Digital Input Set Up Group .....	51
Display Set Up Group.....	52

Lock Set Up Group .....	53
Read Status Set Up Group.....	55
Drive Set Up Group .....	56
Maintenance Set Up Group.....	59
Regions of Motor Travel .....	62
CAL POSOUT Group .....	63
Auto - Manual Drive Switch .....	64
Calibration .....	65
Setting End-of-Travel Limit Switches .....	78
Setting Auxiliary Switches .....	81
<b>Start-Up/Operation .....</b>	<b>83</b>
Introduction.....	83
Power-up Diagnostics.....	83
Operations Checklist .....	83
Operating Displays .....	84
Motor Stall .....	84
Position Sensor Operation .....	85
Remote Setpoint Operation .....	85
<b>Maintenance.....</b>	<b>87</b>
Introduction.....	87
Basic Maintenance .....	87
Replacement Procedures.....	89
<b>Replacement/Upgrade/Accessory Kits .....</b>	<b>91</b>
Replacement Kits .....	91
Upgrade Kits.....	102
Accessory Kits.....	104
<b>Troubleshooting .....</b>	<b>105</b>
Introduction.....	105
Troubleshooting Procedures .....	106
<b>Appendix A - HercuLine® 2001/2002 Configuration Record Sheet.....</b>	<b>112</b>
<b>Index .....</b>	<b>116</b>

## Tables

Table 1 Specifications - General.....	5
Table 2 Recommended Minimum Wire Size.....	17
Table 3 Terminal Connections: HercuLine® 2000.....	18
Table 4 Terminal Connections: HercuLine® 2001/2002 with auto/manual.....	19
Table 5 Split Range Set Up Procedure.....	26
Table 6 Keypad Description.....	32
Table 7 Set Up Tips.....	33
Table 8 Set Up Groups.....	34
Table 9 Set Up Procedure Using Display and Keypad.....	36
Table 10 Input Set Up Group Parameters.....	39
Table 11 Equal Percentage Valve Characteristics.....	42
Table 12 Quick Opening Valve Characteristic.....	43
Table 13 Relay Set Up Group Parameters.....	44
Table 14 Relay Type Descriptions.....	45
Table 15 Current Out Set Up Group Parameters.....	49
Table 16 Communications Set Up Group Parameters.....	50
Table 17 Digital Input Set Up Group Parameters.....	51
Table 18 Display Set Up Group Parameters.....	52
Table 19 Lock Set Up Group Parameters.....	53
Table 20 Read Status Set Up Group Parameters.....	55
Table 21 Drive Set Up Group Parameters.....	56
Table 22 Maintenance Set Up Group Parameters.....	59
Table 23 CAL POSOUT Group Parameters.....	63
Table 24 Auto - Manual Switch Functions.....	64
Table 25 Input Calibration Procedure.....	69
Table 26 Motor Calibration Procedure.....	70
Table 27 Output Calibration Procedure.....	71
Table 28 Slidewire Emulation Calibration Procedure.....	73
Table 29 NCS Position Sensor Calibration Procedure.....	74
Table 30 Potentiometer Position Sensor Calibration Procedure.....	76
Table 31 Load Position Sensor Factory Calibration.....	77
Table 32 End-of-Travel Limit Switch Setting Procedure.....	79
Table 33 Auxiliary Switch Setting Procedure.....	82
Table 34 Typical Operating Displays.....	84
Table 35 Spur Gear Lubrication Procedure.....	87
Table 36 Motor Drive Fuse Replacment Procedure.....	89
Table 37 Relay PWA Replacement Procedure.....	90
Table 38 Replacement kits.....	96
Table 39 Observable Symptoms of Failure.....	105

## Figures

Figure 1 HercuLine® 2000 Series Actuator	2
Figure 2 HercuLine® 2002 Actuator Internal View	3
Figure 3 Outline and Dimensions of HercuLine® 2000 Series Actuators	14
Figure 4 Constant Torque Linkage	15
Figure 5 Variable Torque Linkage	16
Figure 6 Standard crank arm	16
Figure 7 Crank arm with optional ball joint and push rod	16
Figure 8 HercuLine® 2000 connections	18
Figure 9 HercuLine® 2001/2002 connections	19
Figure 10 HercuLine® 2003 connections	20
Figure 11 CE wiring part 1	21
Figure 12 CE Wiring part 2	22
Figure 13 Burner Control/Flame Safety Wiring	23
Figure 14 Series 90 connections	24
Figure 15 T775 Controller connections	25
Figure 16 Flow Diagram	27
Figure 17 Interconnection Diagram	27
Figure 18 Proportional Flow Using Multiple Actuators	28
Figure 19 Multiple Actuator Interconnection Diagrams	29
Figure 20 Interconnection Diagrams	30
Figure 21 HercuLine® 2000 Display and Keypad	31
Figure 22 Relay connectors	46
Figure 23 Regions of Motor Travel	62
Figure 24 Auto - Manual Switch	64
Figure 25 Calibration Wiring Connections (non-slidewire emulation)	66
Figure 26 Calibration Wiring Connections (slidewire emulation)	67
Figure 27 Jumper Location on CPU PWA	68
Figure 28 Location of NCS Assembly	75
Figure 29 Location of potentiometer position sensor	77
Figure 30 End of Travel Limit Switch Settings	78
Figure 31 Location of End-of-Travel Limit and Auxiliary Switches	80
Figure 32 Auxiliary Switch Settings	81
Figure 33 Terminal Block Connections for Modbus Communications	86
Figure 34 Spur Gear Location	88
Figure 35 Power Distribution PWA and Relay PWA Locations	89
Figure 36 Motor Drive Circuit Fuses	90
Figure 37 Replacement Kits 6, 7, 8, 11, 12, 14	91
Figure 38 Replacement Kit 10	92
Figure 39 Replacement Kits 1, 2, 3, 4, 5, 9, 15, 16, 19	93
Figure 40 Replacement Kit 13	94
Figure 41 Replacement Kits 17, 18	95
Figure 42 Test for Actuator Operation	107
Figure 43 Power Up Diagnostics	108
Figure 44 Test Power Distribution PWA	109
Figure 45 Test AUTO - MANUAL Switch	110
Figure 46 Test Relay Function	111



# Introduction

## Product Description

Honeywell's **HercuLine® 2000** series actuators are available in four versions: **HercuLine® 2000**, **HercuLine® 2001**, **HercuLine® 2002**, and **HercuLine® 2003**. All are low torque, precision electric rotary actuators incorporating all of the high quality and reliable features of the traditional HercuLine series actuators. These precision control and high reliability actuators ensure processes operate at maximum efficiency, with minimal downtime, and lowest lifetime cost.

Honeywell's **HercuLine® 2000** series actuators are precision engineered for exceptional reliability, accurate positioning, and low maintenance (Figure 1). Designed for very precise positioning of dampers and quarter turn valves the **HercuLine® 2000** series actuators perform especially well in extremely demanding environments requiring continuous-duty, high reliability, and low maintenance.

## Model distinctions

**HercuLine® 2000** series actuators are used in applications requiring on/off or power to open/close position proportional with 135 or 1000 ohm feedback.

**HercuLine® 2001** and **2002** are smart actuators used in applications requiring current proportional control or digital control. They offer digital electronics providing for precision positioning control, easy set-up and configuration, on board health monitoring, and network communications. Programming access is provided through our **HercuLink®** Palm PDA software connected to the actuator via a 232/485 converter, via HART communications or through the optional local keypad and display.

**HercuLine® 2002** smart actuators offer features and functions similar to the **HercuLine® 2001** and are used for more severe service applications requiring features such as non-contact position sensing.

**HercuLine® 2003** actuators are unidirectional/ 360 degree rotation, special purpose actuators.

The keypad and display are available on the **HercuLine® 2001** and **HercuLine® 2002** products at additional charge.

## HercuLink® Software

HercuLink® Computer software enables access to programming and communication functions available as standard with the **HercuLine® 2001 and 2002** actuators without the added expense of the keypad & display HMI. Using a Palm™ PDA, laptop PC or desktop computer, HercuLink® software, and a RS232/485 converter users may configure, calibrate, and access maintenance information locally or remotely to the actuator.

Using HercuLink® software, the computer may be used as a master device over a Modbus network to access information to/from the actuators and to control the device. Set-up configurations may also be stored on the computer for download to other HercuLine® devices. Information may be stored on the users PC in CSV format for use in preventative maintenance programs.

- Certified on Palm™ m125, m130, and m505.
- Compatible with Palm OS3.5 or higher.
- Compatible with Windows 2000 or XP operating systems
- Minimum system requirements:
  - Windows 2000 (w/service pack 2), Windows NT (w/service pack 5), Windows ME, Windows XP
  - 200 MHz Pentium with 64 Megs Ram

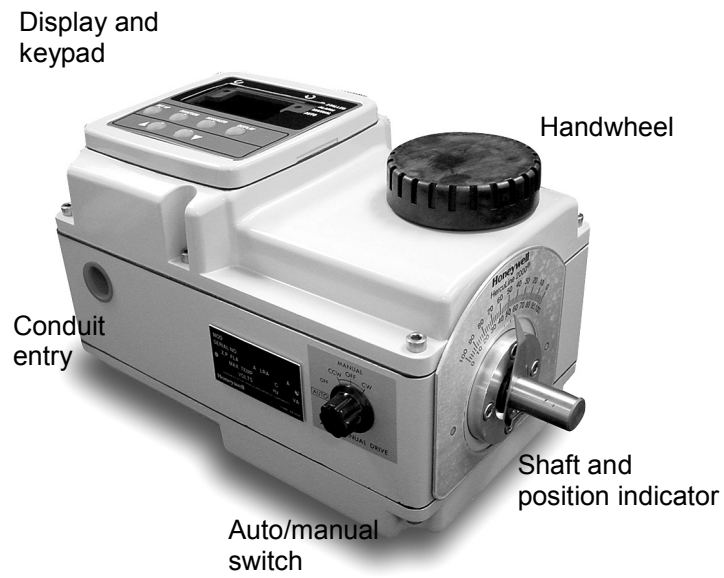

**Figure 1 HercuLine<sup>®</sup> 2000 Series Actuator**

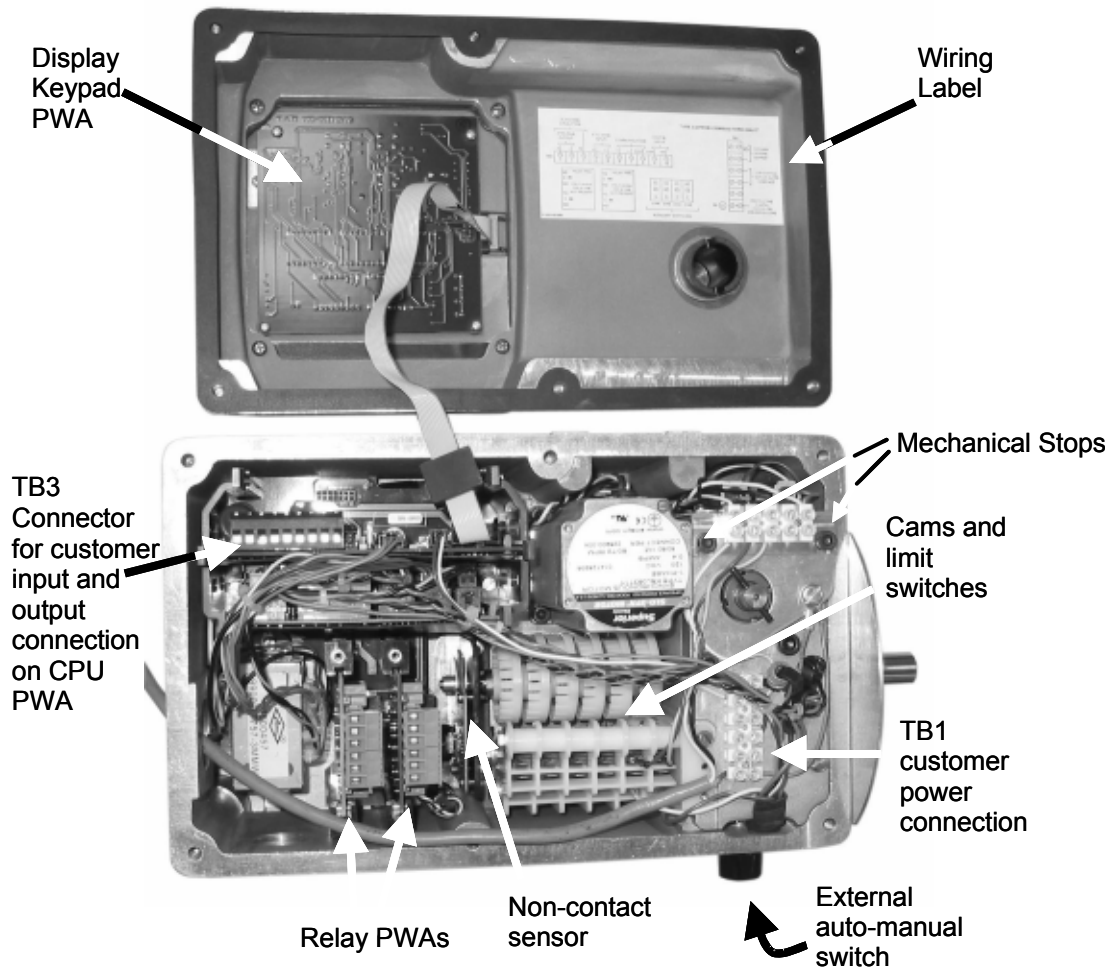

Figure 2 HercuLine® 2002 Actuator Internal View



## Specifications

This section provides you with the technical specifications and the model selection guide for the HercuLine® 2000 Series Actuators.

### Technical and Operating Specifications

**Table 1 Specifications - General**

Physical			
<b>Weight</b>	2000: 25 lb. (11.36 kg) 2001,2002: 27 lbs. (12.27 kg)		
<b>Enclosure</b>	Precision-machined die cast aluminum housing, finished in light gray powder coat epoxy.		
<b>Gear Train</b>	Alloy steel, high efficiency steel spur gear primary train. Precision ground, self-locking/self releasing worm gear final mesh.		
<b>Mechanical Stops</b>	Factory set at 90° or 150° (+/-5°).  <b>Attention: Do not adjust the mechanical Stops. Adjusting the stops will void the warranty</b>		
<b>Storage Temperature</b>	-40 °C to +93 °C (-40 °C to +200 °F)		
<b>Relative Humidity</b>	0 % to 99 % R.H. non-condensing over the full operating temperature range.		
<b>Scale</b>	0 % to 100 % corresponding to full crank arm travel.		
<b>Crank Arm</b>	Adjustable radii 1.0 in (25.4mm) to a maximum of 2.8 in (71.1mm). Position adjustable through 360° rotation.		
<b>Output Shaft</b>	0.625+/-0.005 in (15.88 +/-0.13mm) diameter		
<b>Rotation</b>	90° or 150° degrees between 0 % and 100 % on scale, limited by mechanical stops.		
<b>Manual Handwheel</b>	Provides a means of positioning the actuator in the event of a power failure or set-up.		
<b>Lubrication</b>	Texaco Starplex 2 EP Grease		
<b>Output Torque/Full Travel Stroking Time</b>	<b>Torque lb-in (N M)</b>	<b>50 Hz (90°/150°)</b>	<b>60 Hz (90°/150°)</b>
	50 / (6.0)	4.5 / 7.5	4 / 6
	100 / (11.5)	9 / 15	7 / 12
	200 / (22.5)	18 / 30	15 / 25
	400 / (45.0)	36 / 60	30 / 50
	400 / (45.0)	54 / 90	45 / 75

<b>Electrical</b>	
<b>Mains Supply</b>	100-130 Vac single phase, 50 Hz or 60 Hz 200-240 Vac single phase, 50 Hz or 60 Hz
<b>Motor</b>	Instant start/stop, non-coasting, non-burnout, continuous duty, permanent magnet, synchronous induction motor. Can be stalled up to 100 hours without damage.
<b>Motor Current</b>	= No load = full load = locked rotor = 0.4 amp for 120Vac, 0.2 amp for 240 Vac
<b>Loss of Power</b>	Stays in place on loss of power
<b>Local Auto/Manual Switch</b>	Optional – Allows local and automatic operation of the actuator.
<b>End of travel Limit Switches</b>	Standard – adjustable to limit actuator travel to less than 90 or 150 degrees respectively
<b>Auxiliary Switches/Relays</b>	Optional – Up to 4 additional SPDT switches rated at (10 A at 125 Vac, 5 A at 250 Vac).
<b>Certifications</b>	
<b>Approvals</b>	CSA/UL (Standard) CE Compliant (optional)
<b>Enclosure Rating</b>	Type 4 (NEMA 4), IP66 (standard)
<b>Torque Settings of Crank Arm Bolts</b>	
<b>Clamp Bolt</b>	88 lb-in (10 N-m)

## Electrical and Performance Specifications

	HercuLine® 2002	HercuLine® 2001	HercuLine® 2000/2003
<b>Input Signals</b>	Analog: <ul style="list-style-type: none"> <li>• 0/4 to 20 mA (With CPU PWA jumper in current position)</li> <li>• 0/1 to 5 Vdc</li> <li>• 0 to 10 Vdc</li> </ul> Digital: <ul style="list-style-type: none"> <li>• Modbus RTU (RS485)</li> </ul>	Analog: <ul style="list-style-type: none"> <li>• 0/4 to 20 mA (With CPU PWA jumper in current position)</li> <li>• 0/1 to 5 Vdc</li> <li>• 0 to 10 Vdc</li> <li>• Series 90 control</li> </ul> Digital: <ul style="list-style-type: none"> <li>• Modbus RTU (RS485)</li> </ul>	120 vac drive open/120 vac drive close  240 vac drive open/240 vac drive close
<b>Isolation</b>	Input signal, output signal and power are isolated from each other.		NA
<b>Load Requirement (4-20)</b>	Current Out — 0 to 1000 ohms		NA
<b>Input Impedance</b>	0/4 to 20 mA 0/1 to 5 Vdc 0-10 vdc	250 ohms 10 K ohms	NA
<b>Feedback</b>	0 to 20 mA, 4 to 20 mA 0 to 5 Vdc & 1 to 5 Vdc with 250 ohm resistor, (0 to 16 Vdc with 800 ohm resistor)		Dual output 1000 ohms over 90 degrees (135 ohms with 158 resistor)  Dual output 1000 ohms over 150 degrees (135 ohms with 158 resistor)

	HercuLine® 2002	HercuLine® 2001	HercuLine® 2000/2003
<b>Feedback</b>	Slidewire emulation - Provides output voltage ratiometric to shaft position and potentiometric to supply voltage (1 Vdc to 18 Vdc) without a slidewire. Emulates a 100 ohm to 1000 ohm slidewire. 10 mA output maximum.		
<b>Communications</b>	Modbus RTU or optional HART™		NA
<b>Operating Temperature</b>	-40°C to +75 °C (-40°F to +170 °F)		-40°C to +85 °C (-40°F to +185 °F)
<b>Position sensing</b>	Non-contact position sensor	1000 ohm film potentiometer	Dual 1000 ohm film potentiometers (not on 2003)
<b>Sensitivity</b>	0.2 % to 5 % of 90° span, proportional to deadband		NA
<b>Hysteresis</b>	Less than 0.4 % of full scale		NA
<b>Deadband</b>	0.2 % to 5 % of 90° span, programmable. Shipped at 0.5 %		NA
<b>Repeatability</b>	0.2 % of 90° span		NA
<b>Repositions (minimum @ 90 or 150 degree stroke)</b>			
Table 1 option -050-	160	120	500
Table 1 option -100-	290	250	
Table 1 option -200-	450	400	
Table 1 option -400-	700	400	
Table 1 option -600-	900	400	
<b>Voltage/ Supply Stability</b>	0.25 % of span with +10/-15 % voltage change		NA
<b>Temperature Coefficient</b>	Less than ± 0.030 % of span per degree C for 0 °C to 50 °C Less than ± 0.05 % of span per degree C for -40 °C to 75 °C		NA
<b>Zero Suppression</b>	90 % of span.		NA
<b>Input Filters</b>	Selectable spike and low pass filters.		NA
<b>Solid State Motor Control</b>	Two triac switches for clockwise or anti-clockwise motor operation. Transient voltage protection provided.		NA
<b>Failsafe operation</b>	If input signal exceeds configured input range. Selectable and adjustable.		NA
<b>Direction of Rotation</b>	Field programmable		Wire swap
<b>Duty Cycle</b>	Continuous		

	HercuLine® 2002	HercuLine® 2001	HercuLine® 2000/2003
<b>Programmable Functions</b>	Selectable and configurable operating parameters: <ul style="list-style-type: none"> <li>• Input range</li> <li>• Input filtering</li> <li>• Input characterization</li> <li>• Security</li> <li>• Digital Input action</li> <li>• Deadband</li> <li>• Failsafe on loss of input signal</li> <li>• Failsafe on loss of position sensor</li> <li>• Direction of rotation</li> <li>• Relay closure action</li> <li>• Communication parameters</li> <li>• Split range operation</li> <li>• Output range</li> <li>• Alarms</li> </ul>		NA

### Specifications – Local Display and Keypad

<b>Display</b>	
<b>Display Design</b>	Multi-segment LED displays that provides up to ten alphanumeric characters. Display arrangement consists of two rows:  1 <sup>st</sup> row (Upper display) – four characters  2 <sup>nd</sup> row (Lower display) – six characters.
<b>LED indicators</b>	Six single LEDs provide actuator status and alarm indications.
<b>Display Operating Temperature</b>	-30 °C to +50 °C (-20 °F to +122 °F) Automatically shuts off when operating temperature exceeds +50 °C
<b>Storage Temperature</b>	-40 °C to +93 °C (-40 °F to +200 °F)
<b>Keypad</b>	
<b>Keys</b>	Six single pushbutton keys allow access to all status displays and set up group parameters.

See Set Up and Calibration Procedures (page 31) for detailed information on display and keypad functions.



**Specifications – Communications**

<b>Communications</b>	
<b>Communications Option</b>	RS 485 Serial Communication, Modbus RTU Protocol
<b>Connection</b>	Twisted pair cable with shield
<b>Maximum loop length</b>	600 meters (2000 feet)
<b>Communication Mode</b>	Half duplex
<b>Baud Rate</b>	300, 600, 1200, 2400, 4800, 9600, 19.2K

**Required Specifications – PDA (customer provided)**

<b>PDA</b>	
<b>Operating System</b>	Palm OS version 3.5 or greater
<b>RAM</b>	At least 8 MB
<b>Communications</b>	Serial port with RS232 compatible levels to drive external converter  Note: As of this writing only Palm devices have this feature. Honeywell has qualified the M105, M125, M130, and M505 devices with the HercuLink application.

## Model Selection Guide

### Instructions

- Select the desired key number. The arrow to the right marks the selection available.
- Make the desired selections from Tables I thru VIII using the column below the arrow.  
A dot (•) denotes unrestricted availability.

Key Number	I	II	III	IV	V	VI	VII	VIII	IX
_____	_____	_____	_____	_____	_____	_____	_____	_____	_____

KEY NUMBER - Motor Selection	Selection	Availability			
Basic Motor Unit (no electronics)	2000	↓			
Basic Motor Unit plus Digital Electronics	2001		↓		
Enhanced Performance Motor Unit with Non-contact Position Sensing	2002			↓	
Unidirectional Motor (M640D Replacement)	2003				↓

**TABLE I - TORQUE & SPEED SELECTION (speed per 150 degree rotation)**

Torque, lb-in/(N-M)	50Hz	60Hz				
50 / (6.0)	7.5 sec	6 sec	050	•	•	•
100 / (11.5)	15 sec	12 sec	100	•	•	•
200 / 22.5)	30 sec	25 sec	200	•	•	•
400 / (45.0)	60 sec	50 sec	400	•	•	•
400 / (45.0)	90 sec	75 sec	600	•	•	•

**TABLE II - ROTATION**

Travel					
90 degrees	090	•	•	•	
150 degrees	150	•	•	•	
360 degrees	360				•

**TABLE III - POWER SUPPLY**

Single Phase					
100 - 130 Vac, 60 Hz	126	•	•	•	•
100 - 130 Vac, 50 Hz	125	•	•	•	
200 - 240 Vac, 60 Hz	246	•	•	•	
200 - 240 Vac, 50 Hz	245	•	•	•	

**TABLE IV - ANALOG INPUT/OUTPUT SIGNALS**

Input					
3 Wire Drive up/down	0 __	•			
0/4-20 mA, 0/1-5 Vdc, 0-10 Vdc	2 __		•		
0/4-20 mA, 0/1-5 Vdc, 0-10 Vdc	3 __			•	
0 to 135 ohm input (Series 90 control)	4 __		a		
Contact Input for 2003	6 __				•
Output					
(Note 1) None	_ 00	•	•	•	•
(Note 1) Dual 1000 Ohm (1000 ohms over 150 degrees)	_ 15	b			
(Note 1) Dual 1000 Ohm (1000 ohms over 90 degrees)	_ 19	c			
Slidewire Emulation	_ 60		•		
Slidewire Emulation	_ 65			•	
0/4-20mAdc (0/1-5 Vdc, 0-16 Vdc)	_ 80		•		
0/4-20mAdc (0/1-5 Vdc, 0-16 Vdc)	_ 85			•	

**TABLE V - SWITCH AND RELAY OUTPUTS (2 end-of-travel switches are standard)**

Auxiliary Outputs					
No Auxiliary Switches	0 _	•	•	•	
2 Auxilliary Switches	2 _	•	•		•
4 Auxilliary Switches	4 _	•	•		
Relay Outputs					
No Relays	_ 0	•	•		•
2 Programmable Relay Outputs	_ 2		•		
2 Programmable Relay Outputs	_ 3			•	
4 Programmable Relay Outputs	_ 4		•	•	

*continued*

		2000 2001 2002 2003				
		Selection	↓	↓	↓	↓
Local keypad/ display	No local display interface supplied (Note 2)	0	•	•	•	•
	Integrally mounted local display/keypad interface	1	•	•	•	•
Local Auto/ manual switch	No auto/manual switch	0	•	•	•	•
	Auto/manual switch with "Out of Auto Contact"	1	•	•	•	•
	Auto/manual switch with "Out of Auto Contact"	2	•	•	•	•
Handwheel	No Handwheel	0	•	•	•	•
	Handwheel	1	•	•	•	•
Certificates	None	0	•	•	•	•
	Certificate of Conformance	1	•	•	•	•
Approvals	UL Type 4/IP66, CSA (Note 4)	0	•	•	•	•
	CE	1	•	•	•	•
Shipped Rotation	Counter clockwise shaft rotation on increasing signal	0	•	•	•	•
	Clockwise shaft rotation on increasing signal	1	•	•	•	•

**TABLE VII - COMMUNICATIONS/PROTOCOL**

None	No communications option board or protocol	0	•	•	•	•
Modbus RTU RS485	RS-485 Modbus compliant - standard with EEU	1	•	•	•	•
HART 5	HART Communications Protocol	2	•	•	•	•

**TABLE VIII - MANUALS**

Standard	English	0	•	•	•	•
----------	---------	---	---	---	---	---

**TABLE IX - FACTORY OPTIONS**

Factory Options	None	00	•	•	•	•
-----------------	------	----	---	---	---	---

**Restrictions**

Restriction Letter	Available Only With		Not Available With	
	Table	Selection	Table	Selection
a	IV	_ 00	IV	_ 60, _ 80
b	II	150	II	090
c	II	090	II	150

**ACCESSORIES**

Mounting Hardware	Mounting plate adapter for Barber Colman Series MP495	51452354-501
	Mounting plate adapter for Landis & Staefa SQM53/56	51452354-502
	Direct Couple Valve Hardware	51452354-503
	North American Valve Retrofit Kit	51452354-511
	Linkage Assembly	51452354-504
Linkage Assembly	Ball joint for 5/16" dia. Pushrod	51452354-504
	Pushrod 12 in. (304,5 mm) long, 5/16 " dia.	51452354-505
	Pushrod 18 in. (457,2 mm) long, 5/16 " dia.	51452354-506
	Pushrod 24 in. 609,6 mm) long, 5/16 " dia.	51452354-507
	Pushrod 48 in. (1219,2 mm) long, 5/16 " dia.	51452354-508
HART	Turk Cable for Handheld Connection	51452352-501
Handheld Config. (Note 3)	HercuLink™ Palm Software	51452354-509
	Battery powered 232/485 converter with cable	51452354-510
Remote Mount Control	Remote 4-20 mA requires 135 ohm fdbk, 120V 50/60Hz	R7195A1031
	Remote 4-20 mA requires 1000 ohm fdbk, 120V 50/60Hz	R7195A1056
	Remote 4-20 mA requires 135 ohm fdbk, 220V 50/60Hz	R7195A1064
	Remote 135 ohm input requires 135 ohm fdbk, 120V 50/60Hz	R7195B1021

- Notes:**
- 135 ohm available by parallelling 1K potentiometer with 158 Ohm resistor (supplied).
  - HercuLink™ software (pn 51452354-509), RS232/485 converter (pn 51452354-510), customer supplied Palm™ PDA running OS3.5 or higher and Palm serial cable are required for the 2001 and 2002 actuators if no display is selected.
  - Requires PDA manufacturer's serial interface cable.
  - CSA approval is good for 75°C and a maximum relay load of 3.5 amps or 70°C with a relay load of 5 amps.

# Installation

## Installation Overview

The procedures to install the HercuLine® 2000 Series actuator and place it in service require that you:

- Select a suitable location for installation. (See Installation Considerations below.)
- Mount the actuator securely.
- Install mechanical connections or linkage between control arm and final control element. Use HAL software application to aid in mechanical installation.
- Make all electrical connections for actuator according to local and national electrical codes.
- Power up actuator.
- Enter, verify and adjust set up parameters for proper operation.
- Adjust control arm linkage for accurate operation of final control element.

This section provides you with mechanical and electrical installation information required to mount and connect the HercuLine® 2000 Series Actuator to your specific application. Unpacking instructions, installation considerations, electrical and safety precautions also included in this section should be observed.

## Mechanical Stops

<b>CAUTION</b>
----------------

Factory set at 90° or 150° (+/-5°).

See Figure 2 for location.

<b>Attention: Do not adjust the mechanical stops. Adjusting the stops will void the warranty.</b>
---

## Before Starting

### Unpacking

If there are visible signs of damage to the shipping container, notify the carrier and Honeywell immediately.

If there is no visible damage, compare the contents with the packing list. Notify the carrier and Honeywell immediately if there is equipment damage or shortage.

Please do not return goods without contacting Honeywell Applications Center in advance. The contact number is 1-800-423-9883.

### Installation Considerations

Mount the actuator in a location where it will be easily accessible for maintenance and for manual operation by means of the handwheel. The exact location must be determined in accordance with the linkage used.

It is important that the actuator be mounted securely to a solid foundation commensurate with the maximum torque developed. Use studs or bolts that are as large as the foot mounting holes.

Allocate sufficient clearance around the actuator for the removal of all covers to permit inspection of internal parts and to provide access to the handwheel.

## Actuator Mounting

Firmly bolt the actuator to a mounting surface that will not distort when subjected to the torque stresses generated by the actuator. The output shaft of the actuator should be parallel to the output shaft of the driven device. The output shaft crank arm is fully adjustable through 360°.

Mounting holes (bottom and side) and location of shaft/crank arm duplicate mounting for Honeywell Actionators M640A, 740A, 940A for drop-in replacement. Optional adaptor plates available for replacing Landis and Staefa SQM53/56 and Barber Coleman series MP495 models.

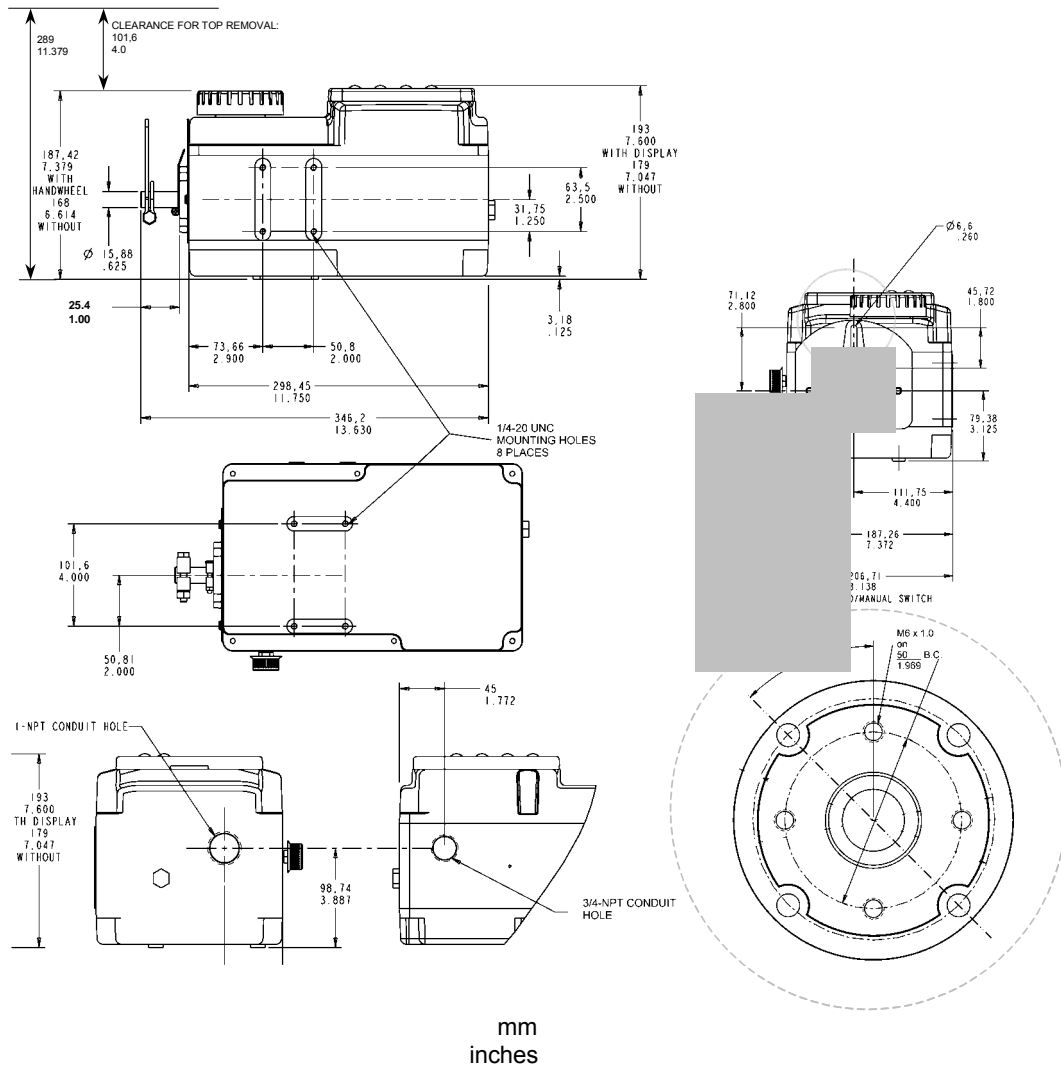

Figure 3 Outline and Dimensions of HercuLine<sup>®</sup> 2000 Series Actuators

## Mechanical Installation

### Linkage Set-up

Many applications require the use of a linkage assembly and often the final control element does not have a linear torque curve. The actuator linkage can be set up to achieve an optimal delivered torque distribution for specific applications. To assist with linkage design, Honeywell offers a linkage analysis software application (HAL). The software can be ordered as P/N 51197910-001.

### **Constant Torque Linkage (typical)**

A constant torque linkage is employed when it is desired to provide a linear torque profile throughout the full range of final control element travel. In this situation, the actuator and driven crank arms will be set-up proportionally with respect to each other. Figure 4 shows a general linkage setup to achieve a linear torque profile.

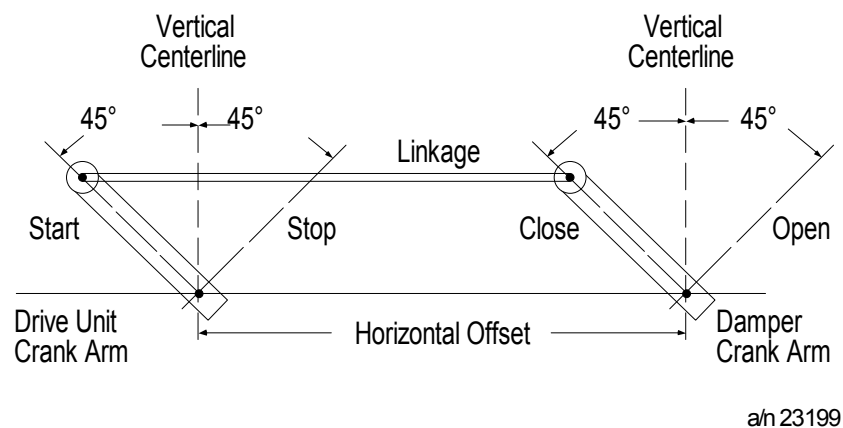

**Figure 4 Constant Torque Linkage**

### **Variable Torque Linkage**

A variable torque linkage is employed when it is desired to provide a non-linear torque profile throughout the full range of final control element travel. In this general situation, the actuator and driven crank arms will be set up to provide a higher torque for seating or unseating the final control element. Figure 5 shows a general linkage setup to achieve a non-linear torque profile. Note that this linkage can be characterized in many different ways by varying start angles and rotation requirements of both the Actuator Crank Arm and the Driven Arm.

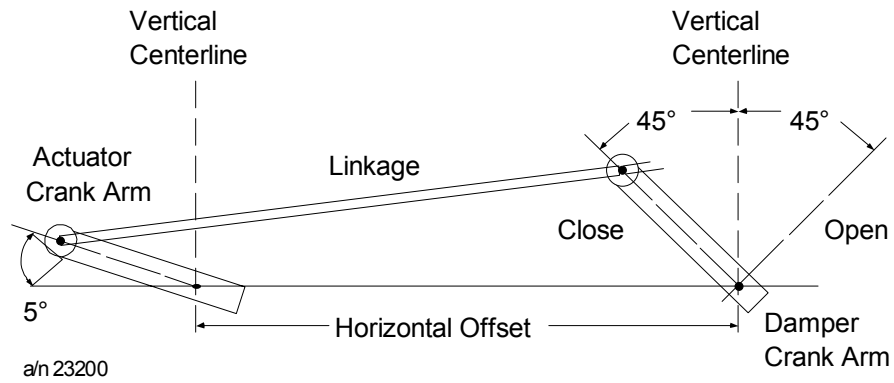

**Figure 5 Variable Torque Linkage**

### **Actuator Crank Arms**

The Herculine<sup>®</sup> 2000 Series Actuator comes standard with a crank arm with adjustable radius of 1.0 in (25.4mm) to 2.80 in (71.12mm). See Figure 6.

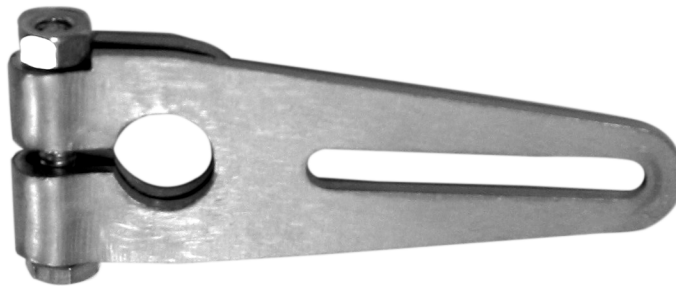

**Figure 6 Standard crank arm**



**Figure 7 Crank arm with optional ball joint and push rod**



## Electrical Installation

### General Wiring Recommendations

---

**⚠ WARNING** Only qualified personnel should perform wiring.  
Wiring must conform to national and local electrical codes.

---

In general, copper wire used. Unless locally applicable codes dictate otherwise, the recommended minimum wire sizes in Table 2 should be observed.

**Table 2 Recommended Minimum Wire Size**

AWG	Description
14	Earth ground wire to common power supply.
18	Earth ground wire to single actuator. 120/240 V ac line leads. +24 V and common signal leads. Common signal leads, relays, and aux switches.

### Safety Precautions

---

**⚠ WARNING** An external disconnect switch must be installed to break all current carrying conductors connected to the actuator. Turn off power before working on conductors. Failure to observe this precaution may result in serious personal injury.

---

### Actuator Connections

---

**H** **ATTENTION**  
 The ground terminal must be connected to a reliable earth ground.

---

**⚠ WARNING** While the unit is powered, a potentially lethal shock hazard exists inside the case. Do not open the case while the unit is powered. Do not access the terminals while the unit is powered.

---

The actuator terminal connections for the field wiring are located behind the cover on the actuator case as shown in Figure 2. Power and field wiring is brought into the actuator through two access holes located on the side of the actuator case.

---

**CAUTION** Use both openings: one for low level wiring (control signal) and the other for high level wiring (120Vac).  
**Do not run both the High Level and Low Level wiring through the same opening.**

---

The screw terminals, locations, and descriptions for all customer connections are identified in the tables and figures that follow.

**HercuLine® 2000 Terminal Connections**

**Table 3 Terminal Connections: HercuLine® 2000**

Connection	Terminal Numbers and LABEL See Figure 8	Descriptions
Hot	1	Hot wire for 120/240VAC mains supply. Use only if Auto/Manual switch is present.
Neutral	2	Neutral wire for 120/240VAC mains supply
Auto/Manual Switch Contact	3 4	Switch contact to indicate setting of actuator AUTO/MANUAL switch. Switch is closed when actuator is "NOT-IN-AUTO"
CW from Controller	5	CW motor drive
CCW from Controller	6	CCW motor drive
Potentiometer #1	7 8 9	Clockwise-End Slider Counterclockwise-End
Potentiometer #2	10 11 12	Clockwise-End Slider Counterclockwise-End
Protective Ground		Ground wire connection for mains supply

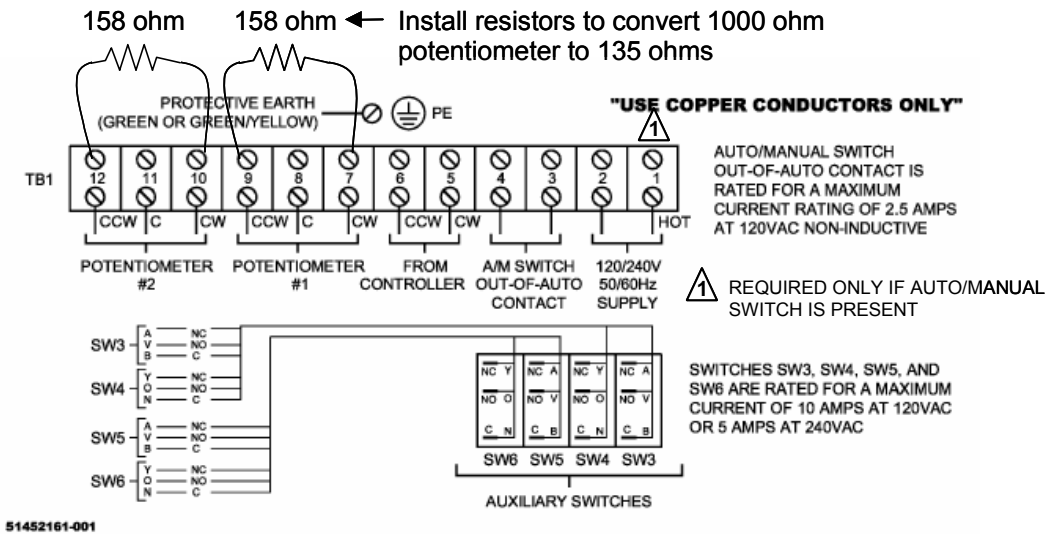

**Figure 8 HercuLine® 2000 connections**

HercuLine® 2001/2002 with Auto/Manual Terminal Connections

Table 4 Terminal Connections: HercuLine® 2001/2002 with auto/manual

Connection	Terminal Numbers and LABEL See Figure 9	Descriptions
	<b>TB1</b>	
Hot	1	Hot wire for 120/240VAC mains supply
Neutral	2	Neutral wire for 120/240VAC mains supply
Protective Ground	3	Ground wire connection for mains supply
Auto/Manual Switch Contact	4 5	Switch contact to indicate setting of actuator AUTO/MANUAL switch. Switch is closed when actuator is "NOT-IN-AUTO"
	6	
	<b>TB3</b>	
4 to 20mA Output*	1 (+) 2 (-)	Analog signal output
Feedback	3	Feedback signal used in conjunction with 4 to 20mA OUTPUT voltage when using Slidewire Emulation
4 to 20mA Input	4 (+) 5 (-)	Analog signal input
Modbus Communication	6 (+) 7 (-) 8 Shield	Connection for RS485 Modbus loop wires
HART Communications	4 (+) 5 (-)	HART Communication is 4-20 mA only.
Digital Input	9 Com 10 Input	Customer's contact closure

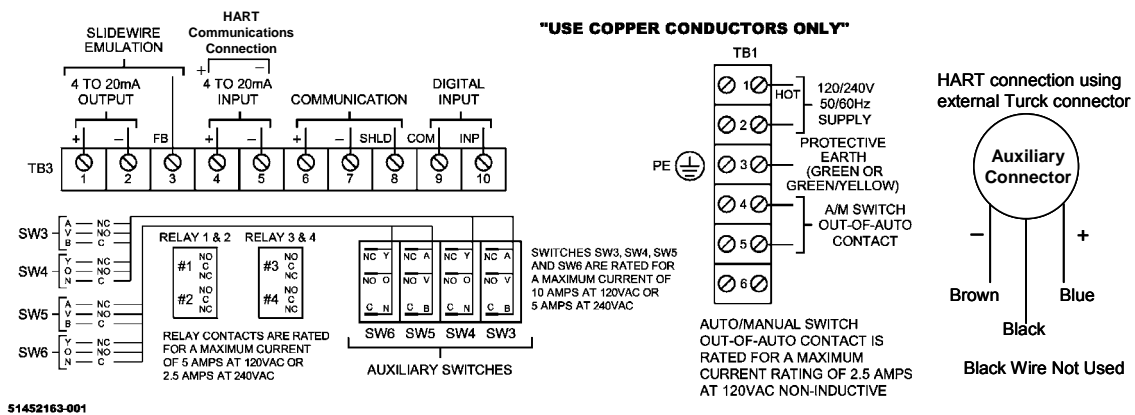

Figure 9 HercuLine® 2001/2002 connections

## HercuLine® 2003 Wiring Connections and Operation (Actionator 640D Replacement)

### Wiring

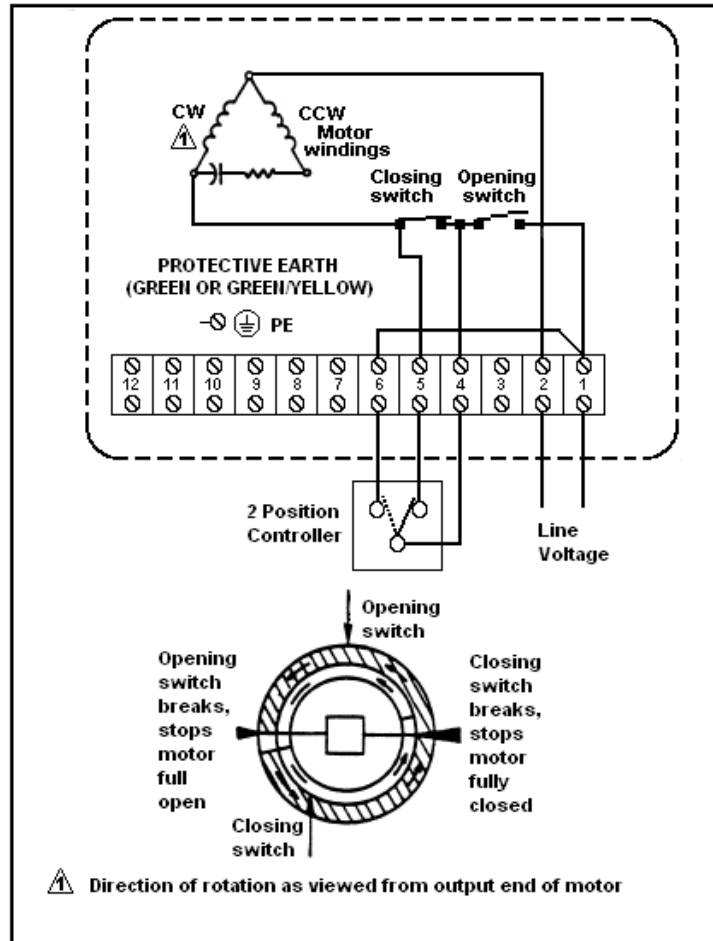

Figure 10 HercuLine® 2003 connections

### Operation

The 2003 actuator is uni-directional (it does not reverse rotation with a reversal in control action). Figure 10 illustrates the internal wiring and the external connections.

The smaller insert of the figure describes the limit switch action for one complete cycle. When the two-position controller detects a sufficient fall in temperature in a heating application, the switch portion between the “4” and “5” terminals will close.

The motor then rotates for 180° or until the opening switch breaks (stops are adjustable, factory set at 180°), and stops in full open position.

A subsequent rise in temperature causes the controller to close the switch between the “4” and “6” terminals when the motor will start to rotate (in the same direction) for 180° or until the closing switch breaks.

The motor stops in the closed position and completes one cycle.

## Power Connections

Depending on which power supply selection is ordered for your actuator, wire the power input (MAINS POWER) as described in the previous tables and figures. Wiring must conform to national and local electrical codes.

## CE Wiring

When wiring the actuator power input for CE approved units, you must also install a MOV and ferrite beads supplied with the CE unit.

You need the following tools:

- 5mm hex key
- small flat blade screwdriver
- small needle nose pliers

**⚠ WARNING** While the unit is powered, a potentially lethal shock hazard exists inside the case. Do not open the case while the unit is powered. Do not access the terminals while the unit is powered.

Step	Action
1	Remove AC power to actuator.
2	Loosen the 6 captive screws (use 5mm hex key) and remove the cover.
3	Locate the terminals TB1-1, TB1-2 and ground screw.
4	Loosen the screws at terminals TB1-1 and TB1-2. Remove screw used for ground.
5	Install the appropriate MOV assembly as shown in Figure 11.
6	All ferrites require 1 loop of wire per ferrite. Connect as shown in following steps.
7	<ul style="list-style-type: none"> <li>• Current input and output (slidewire emulation) connection</li> <li>• Communications and digital input connection</li> </ul>

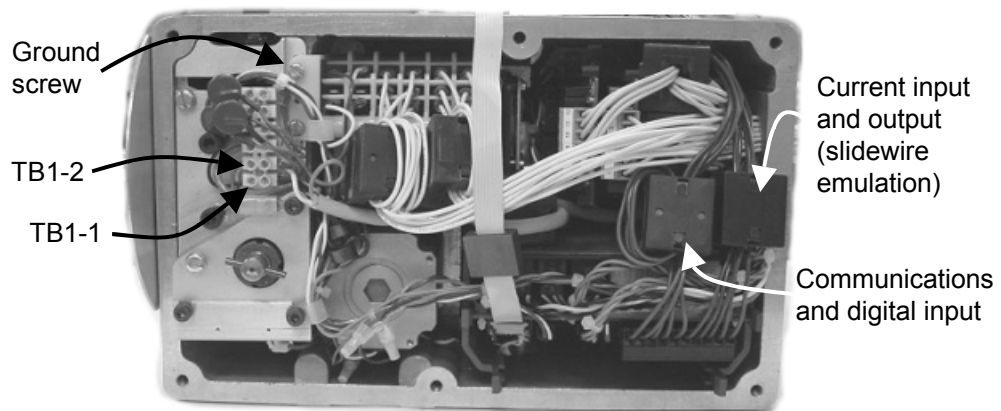

**Figure 11 CE wiring part 1**

Step	Action
8	<ul style="list-style-type: none"><li>• AC power connection</li><li>• Auxiliary switches connection</li><li>• Relay contact connection</li></ul>

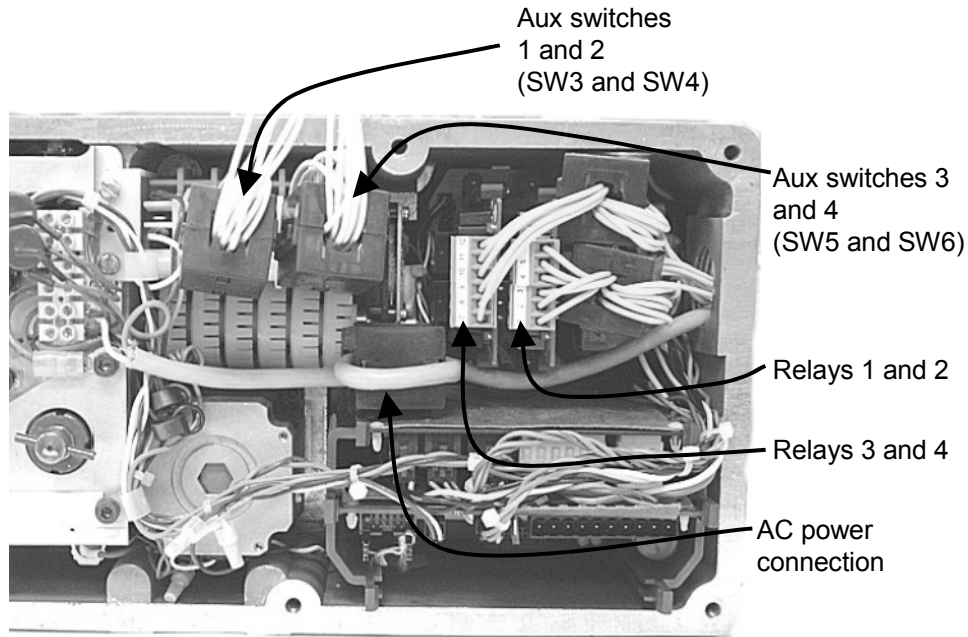

**Figure 12 CE Wiring part 2**

9	Install new gasket and top cover. Secure top cover with 6 captive screws.
10	Reapply AC power to the actuator.
11	Actuator is ready for use.

### Input Signal Connections



#### ATTENTION

Shielded and grounded cables are recommended.

### 0/4-20 mA Input Signals

For current signal input, ensure jumper W2 on the CPU PWA is in the “Current” position. See Figure 27 on page 68. Observing polarity, connect the signal input wires TB3-4(+) and TB3-5(-) on CPU terminal board.

### 0/1-5 Vdc and 0 to 10 Vdc Input Signals

For voltage signal input, ensure jumper W2 on the CPU PWA is in the “Voltage” position. See Figure 27 on page 68. Observing polarity, connect the signal input wires to terminals TB3-4(+) and TB3-5(-) of the terminal block.

## Output Signal Connections

### 0/4-20 mA, 0/1-5 Vdc Feedback Signal Connections



#### ATTENTION

Shielded and grounded cables are recommended.

Actuator output is a 4 to 20 mA analog signal. If a voltage input is required for customer devices, a range resistor is needed at the device input. Refer to (page 19) for more information.

### Slidewire Emulator Connections



#### ATTENTION

Shielded and grounded cables are recommended.

If you ordered the Slidewire output option for your actuator, it is set at the factory to provide an output that emulates 100 to 1000 ohm slidewires. Refer to (page 19) for more information.

# Burner Control/Flame Safety

## Introduction

Often, Gas Fired control applications use a Flame Safety System that drives the gas valve to full closed and full open during the start-up sequence for the burner. HercuLine® 2000 Series actuators have been designed to be compatible with the Flame Safety Systems and to perform the required operations.

## Configuration

In the Input Set Up Group (Page 39), configure the parameter FSTYPL to Down .  
In the Digital Input Set Up group (Page 51), configure the parameter DIG INP to Up.

## Wiring

Figure 13 Burner Control/Flame Safety Wiring shows a Typical Flame Safety Module wiring diagram.

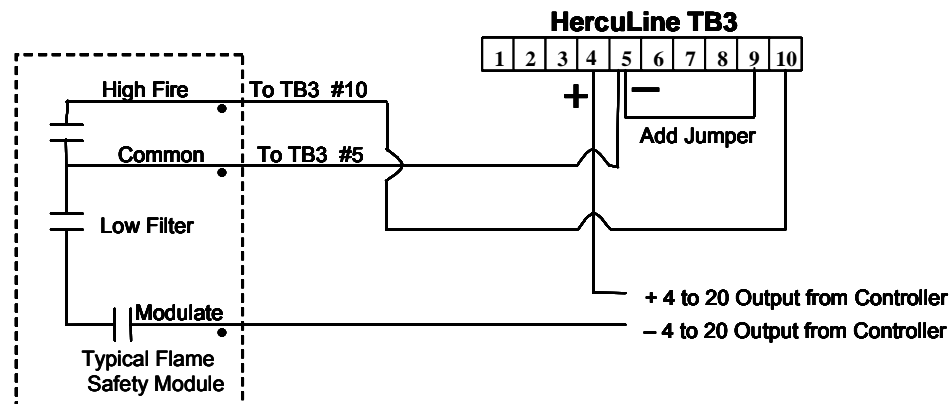

Figure 13 Burner Control/Flame Safety Wiring

## Series 90 Control – HercuLine® 2001 model only

Series 90 Controls are commonly used in building environmental systems and flame safeguard systems to provide modulating control. The control is affected by balancing a 135 ohm potentiometer. The HercuLine 2001 provides an emulation of this system as follows. The current output is used to excite the potentiometer in the controller. To do this it is set permanently at 11 ma. This produces a 1.5 volt span. The wiper is then connected to the HercuLine 2001 input, which is operating in voltage mode. The returns from both the input and the output are tied together.

Series 90 terminals are typically color coded white, red and blue. Conventionally, red is the wiper and white and blue are the two ends of the potentiometer. On a drop in temperature, the wiper moves toward the blue terminal.

### Connections

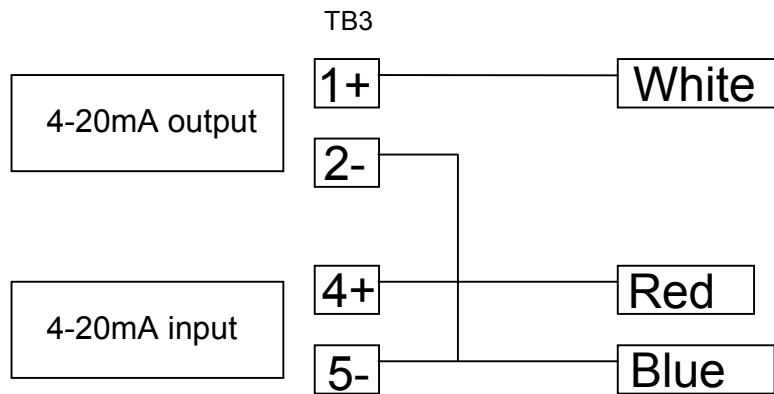
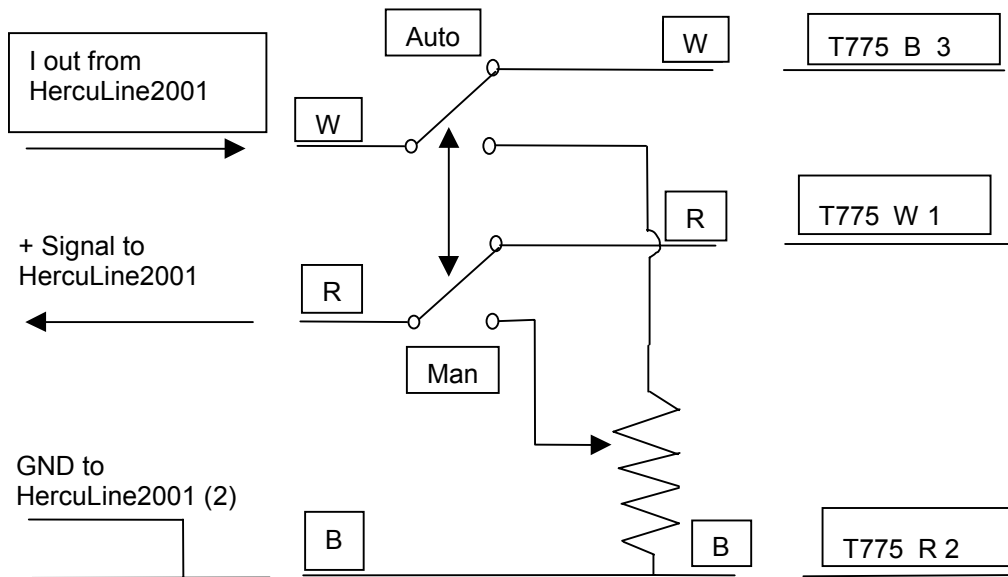

Figure 14 Series 90 connections

### Considerations

1. This connection performs an emulation of a series 90 motor. If the controller being used is also an emulation of a Series 90, the connections required may be different. Shown in Figure 15 are the connections found necessary to connect a T775 controller through an S443A S90 Auto/Manual Control. If the controller has the capability to provide a 4/20 or voltage output, it is easier to use that mode. It will require only two wires and it will allow the independent use of the 4/20 output. If help is required, contact Honeywell.
2. Due to variations in the definition of rotation directions, it may be necessary to reverse the action of the actuator from CCW to CW or vice versa.





**Figure 15 T775 Controller connections**

3. In the T775 controller manual there are several examples of using resistances or potentiometers as high and low limit controls. Because of the mode of emulation of Series 90, it is likely that these connections will not work as intended. Instead, use the output or input limits which are programmable in the HercuLine® 2001.

## Split Range

The HercuLine® 2001/2002 actuators can be set up to operate within a narrow input range (for example, 4 to 12mA input) in certain applications. The procedure in Table 5 describes how to set up an actuator to operate as part of a split valve configuration.

**Table 5 Split Range Set Up Procedure**

Step	Action
<b><i>To Set Actuator span to operate from 4 to 12 mA input.</i></b>	
1	Enter Set Up mode by pressing SET UP key
2	Select SET INPUT group
3	Press FUNCTION key until INP HI (on lower display) is selected.
4	Set INP HI value to 50.0
5	Press FUNCTION key to select INP LO and set value to 0.0
6	Press DISPLAY key to exit Set Up mode.
<b><i>To Set Actuator span to operate from 12 to 20 mA input.</i></b>	
1	Enter Set Up mode by pressing SET UP key
2	Select SET INPUT group
3	Press FUNCTION key until INP HI (on lower display) is selected.
4	Set INP HI value to 100.0
5	Press FUNCTION key to select INP LO and set value to 50.0
6	Press DISPLAY key to exit Set Up mode.
	<b>ATTENTION</b> Be sure to review failsafe strategy for your process application.

## Master/Slave Arrangement

### Introduction

With the motor positioner, the controlling signal for the actuator is a 4 to 20mA from a current output controller as shown in the flow diagram in Figure 16.

Unlike the position output controller, the current output controller must produce a continuous analog signal or the actuator will revert to one of its failsafe states. Signal failure is not a problem since the available failsafe settings allow you to set the actuator position on signal loss.

### Basic Flow Control

When the process variable signal is below set point, the controller increases current (4 to 20mA) to the actuator input and opens the valve. Controller set point governs valve position to obtain desired flow rate.

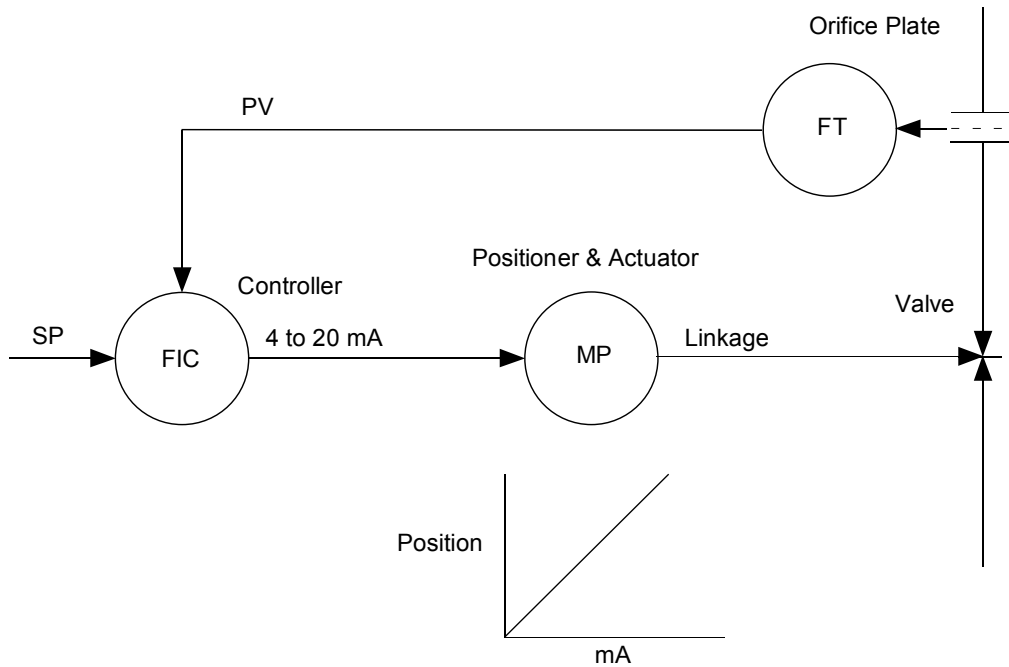

Figure 16 Flow Diagram

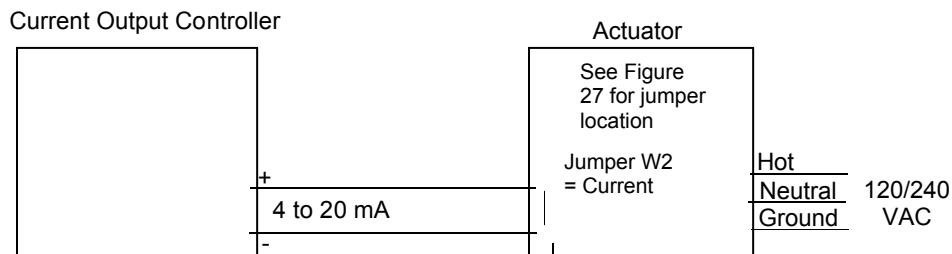
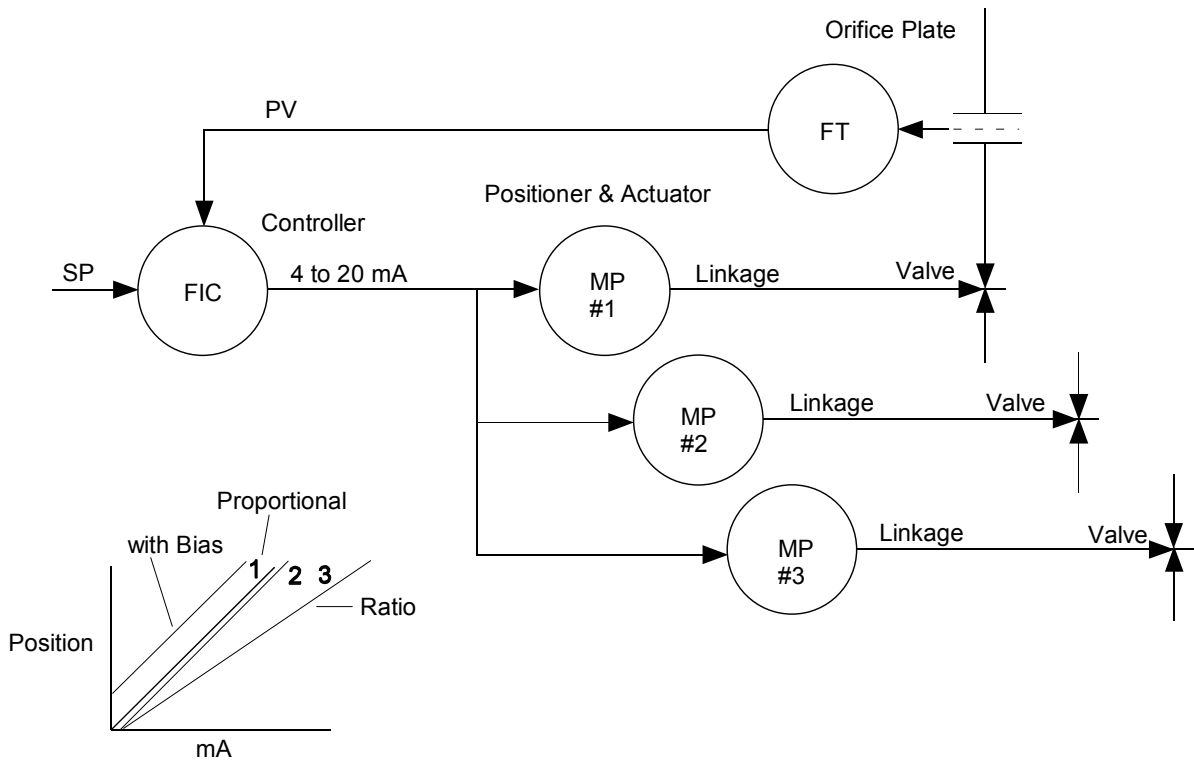

Figure 17 Interconnection Diagram

### Proportional Flow using Multiple Actuators

Refer to flow diagram in Figure 18 and interconnection diagrams in Figure 19. The controller governs flow rate in one burner. Only that flow is measured. Since #2 and #3 motor positions receive the same signal as #1 motor positioned, valves #2 and #3 will deliver the same amount of fuel. This is true when the span and zero adjustment are all set the same as in curve 2 of the graph. Other relationships between units exist if the span adjustment (3) for ratio or if the zero adjustment is changed (1) for bias.



**Figure 18 Proportional Flow Using Multiple Actuators**

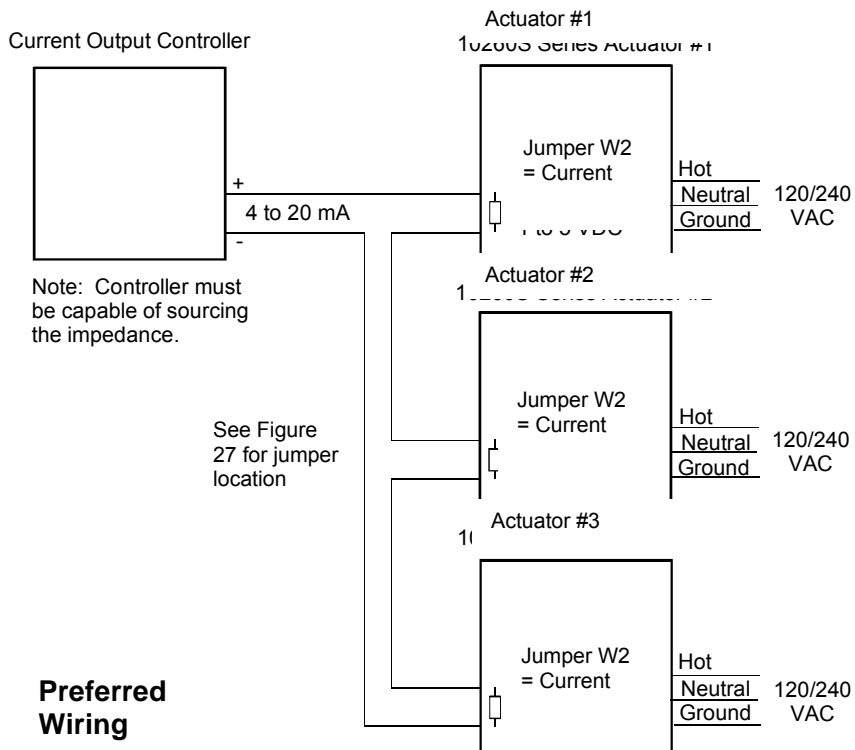

**NOTE: If using HART® communications, for this application HART® must be configured for Multi-drop operation.**

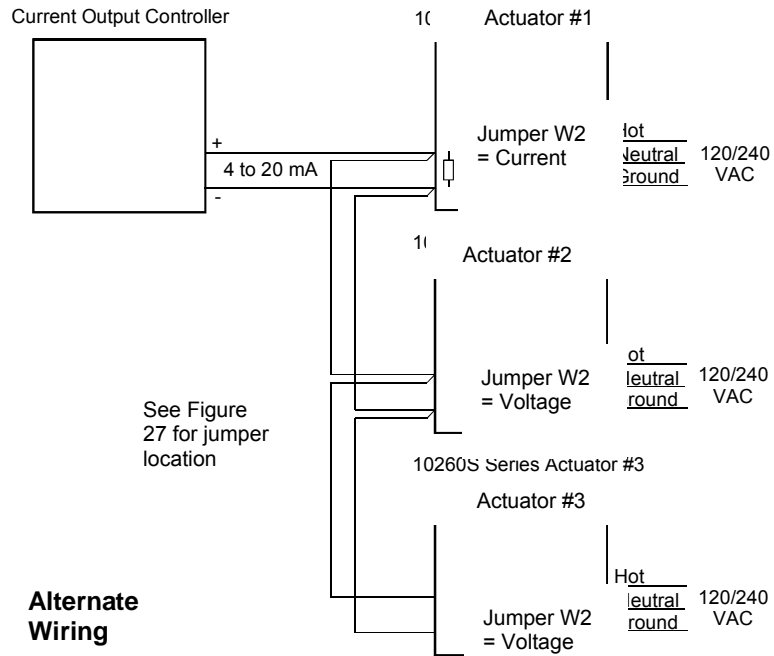
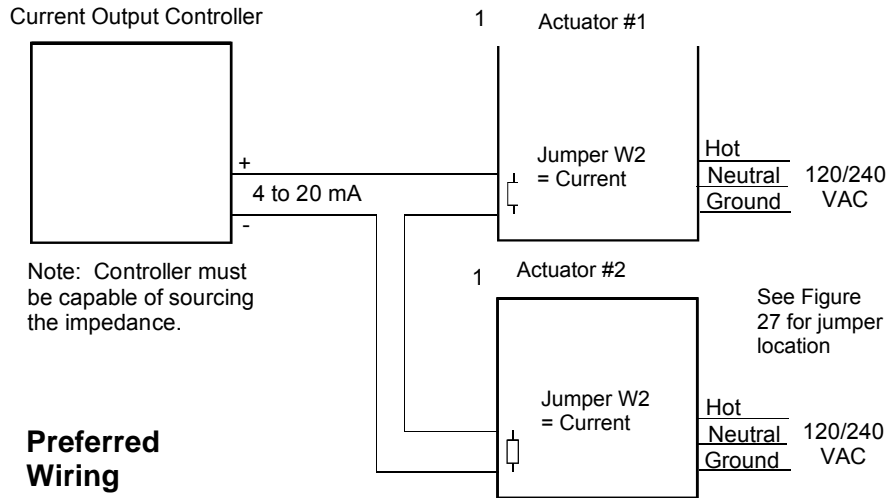

**Figure 19 Multiple Actuator Interconnection Diagrams**

**NOTE: If using HART® communications, for this application HART® must be configured for Multi-drop operation.**

### Split Valve Configuration

A common heat or cool type process requires two valves. In this case the controller has only one output. The two motor positioners are calibrated differently, one responds to 4 to 12mA and the other responds to 12 to 20mA. At 12mA, both valves are closed; one opening below 12mA and the other above 12mA. Refer to Figure 20 for an interconnection diagram for split valve operation using two actuators.



**NOTE: If using HART® communications, for this application HART® must be configured for Multi-drop operation.**

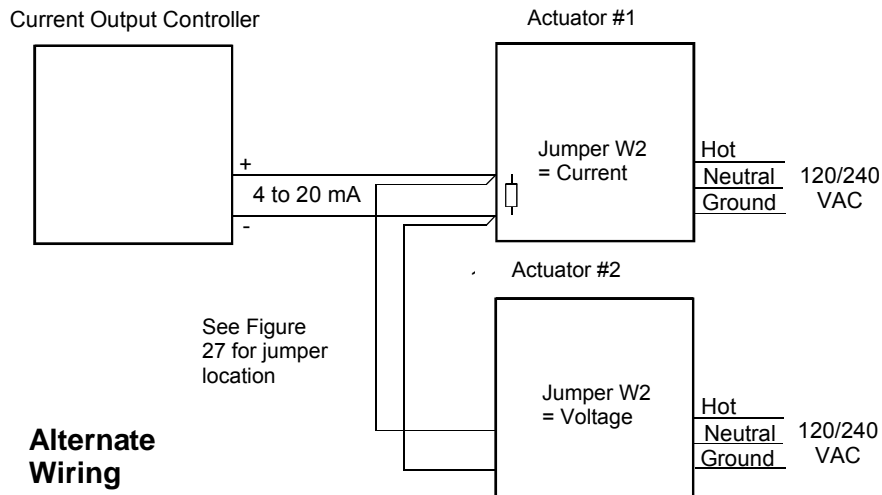

**Figure 20 Interconnection Diagrams**

**NOTE: If using HART® communications, for this application HART® must be configured for Multi-drop operation.**

## Set Up and Calibration Procedures

### Overview

Once you have installed the actuator, you can verify, set or change certain operating parameters. Set up is accomplished through use of the local display and keypad interface through your PDA with HercuLink<sup>®</sup> software (see HercuLink<sup>®</sup> manual 62-86-25-11) or via the HART<sup>®</sup> communication option. Please keep in mind that the unit is calibrated at the factory for your application and can be placed into service right out of the box. Changing operating parameters may require recalibration of the actuator. This section details the various operating parameters and functions of the actuator available using the local display and keypad interface, and calibration procedures.

### Local Display and Keypad

The alphanumeric display and keys on the keypad are the local operator interface for control, monitoring, and configuration of the actuator. The display consists of a four character upper display and a six character lower display. Six LEDs of various colors indicate actuator-operating status. Directly below the display are six keys that allow you to setup, monitor, and control the actuator locally, as well as call up various operating parameters and configuration values on the display. Figure 21 shows the physical features of the display and keypad. Table 6 summarizes the various functions you can perform using the keys as well as descriptions of the status indicators.

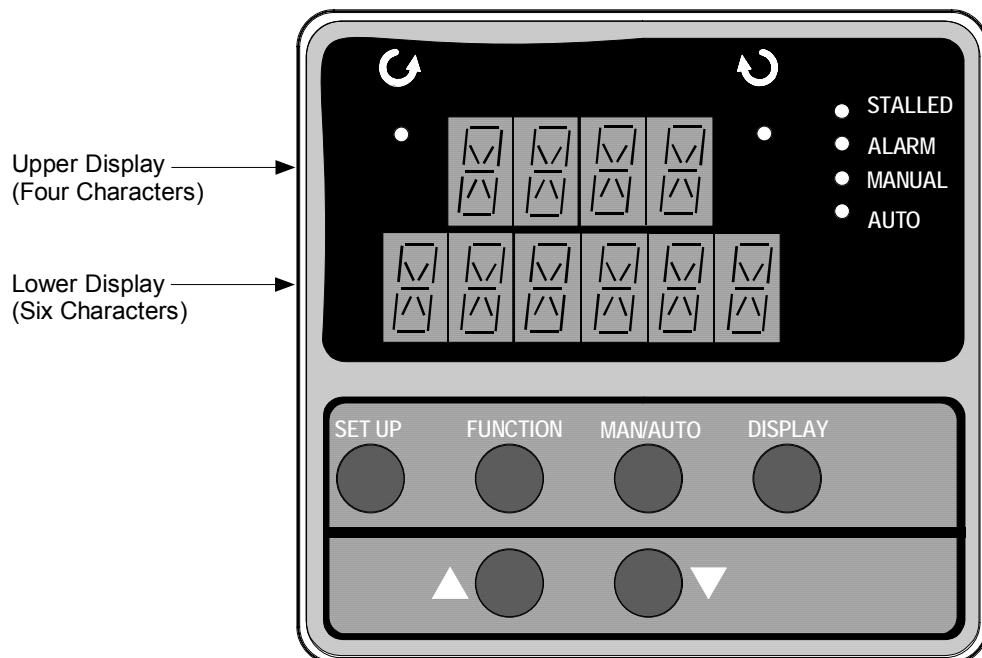







Figure 21 HercuLine<sup>®</sup> 2000 Display and Keypad

**Table 6 Keypad Description**

Key or LED Indicator	Function
SET UP	<p>Places the actuator in the set up group select mode. Sequentially displays the set up groups and allows the FUNCTION key to display function parameters within the set up group.</p> <p>See Set Up and Calibration Procedures (page 31)<b>Error! Reference source not found.</b> for descriptions of the various options available in the set up groups.</p>
FUNCTION	<p>Used in conjunction with the SET UP key to select the individual functions of a selected configuration set up group.</p> <p>Used during field calibration procedure.</p>
MAN/AUTO	<p>Alternately selects:</p> <p><b>MAN</b> - Actuator is in Manual mode.</p> <p><b>AUTO</b> - Actuator is in Automatic mode.</p> <p>NOTE: When in Manual mode the POS display is automatically selected so you can use the up and down arrow keys to drive actuator motor manually.</p> <p>NOTE: This button is disabled if MAENAB is set to DIS. See Table 19 (page 53).</p>
DISPLAY	<p>Pressing this key repeatedly cycles through the operating parameters that can be shown on the lower display.</p> <p><b>INP</b> – Input. Shows the value of the actuator input.</p> <p><b>OP</b> – Output. Shows the value of the actuator output</p> <p><b>DE</b> – Deviation. Shows deviation between input value and actuator position.</p> <p><b>POS</b> – Position. Shows current actuator position.</p>
INCREMENT	<p>Increases the configuration values shown on the display. Also shown as ▲.</p> <p>In manual mode and POSition display selected, pressing this key will drive actuator motor in direction of increasing signal input.</p>
DECREMENT	<p>Decreases the configuration values shown on the display. Also shown as ▼.</p> <p>In manual mode and POSition display selected, pressing this key will drive actuator motor in direction of decreasing signal input.</p>
	<p>Indicates the movement of the actuator arm in the counterclockwise direction.</p> <p>NOTE: Actuator rotation is the direction of the output shaft when facing the end of the shaft and refers to the direction of rotation on increasing signal.</p>
	<p>Indicates the movement of the actuator arm in the clockwise direction.</p> <p>NOTE: Actuator rotation is the direction of the output shaft when facing the end of the shaft and refers to the direction of rotation on increasing signal.</p>
 STALLED	<p>Indicates that the actuator has detected a motor stall condition.</p>
 ALARM	<p>Indicates a programmed alarm condition exists.</p>
 MANUAL	<p>Indicates actuator is in manual mode</p>
 AUTO	<p>Indicates actuator is in automatic mode.</p>



## Set Up Tips

Table 7 contains tips that will help you view, verify and enter the operating parameters more quickly. If you cannot change the parameters, check the status of the “SET LOCK” parameter. Also some parameters require that you enter a security password before you access or change the parameter value.

**Table 7 Set Up Tips**

Function	Tip
<b><i>Displaying Groups</i></b>	Use the SET UP key to display and scroll through the set up groups. The group titles are listed in the order that they appear on the actuator display.
<b><i>Displaying Functions</i></b>	Use the FUNCTION key to display the individual function parameters under each set up group. The prompts are listed in the order of their appearance in each group. See Tables 8 through 19.
<b><i>Scrolling</i></b>	Pressing and holding the SET UP key will scroll through the set up groups. However, when any set up group is displayed, you can scroll through the set up groups twice as fast using the ▲ or ▼ key. When in any set up group, hold the FUNCTION key in to scroll through the prompts within that group.
<b><i>Changing values quickly</i></b>	<p>When changing the value of a parameter, you can adjust a more significant digit in the upper display by holding in one key ▲ or ▼ and pressing the other ▲ or ▼ at the same time.</p> <ul style="list-style-type: none"> <li>• The adjustment will move one digit to the left.</li> <li>• Press the key again and you will move one more digit to the left.</li> </ul>
<b><i>Exiting Set Up mode</i></b>	To exit Set Up mode, press the DISPLAY key. This returns the display to the same state it was in immediately preceding entry into the Set Up mode.
<b><i>Timing out from Set Up mode</i></b>	If you are in Set Up (configuration) mode and do not press any keys for thirty seconds, the actuator display will time out and revert to the mode and display that was being used prior to entry into Set Up mode.

## Set Up Groups

Pressing the SET UP key on the keypad provides access to the various set up groups and allows you to set up operating parameters, (such as input types and alarms), calibrate the actuator's inputs and outputs, set communications, and check actuator status. Table 8 on the next page lists the set up groups that are available by using the SET UP and FUNCTION keys on the keypad.

**Table 8 Set Up Groups**

Set Up Group Title	Pressing the FUNCTION Key Allows You to...	For Details, See
<b>SET INPUT</b>	Select and set various parameters associated with the input signal to the actuator.	<b>Table 10</b>
<b>SET RELAY<sub>n</sub></b> <i>n = 1, 2, 3, or 4</i>	Select relay functions. NOTE: Set Relay groups will show on display only if relays are installed in the actuator.	<b>Table 13</b>
<b>SET CUROUT</b>	Select the output signal type of the actuator.	<b>Table 15</b>
<b>SET COMM</b>	Select communication parameters for remote control of actuator when connected to a SCADA system.	<b>Table 16</b>
<b>SET DIGINP</b>	Select the parameters for external digital input states.	<b>Table 17</b>
<b>SET DISPLA</b>	Select and set parameters for the local display.	<b>Table 18</b>
<b>CAL INPUT</b>	Calibrate input zero and span values.	<b>Calibration Procedure, Table 25</b>
<b>CAL MOTOR</b>	Calibrate zero and span values for motor operation. <b>ATTENTION</b> When calibrating the motor to a short stroke range, you must reset the end-of-travel limit switches. See <i>Setting End-of-Travel Limit Switches</i> .	<b>Calibration Procedure, Table 26</b>
<b>CAL CURENT</b>	Calibrate actuator output.	<b>Calibration Procedure, Table 27</b>
<b>SET LOCK</b>	Set or change security password. Enable or disable security access to set up parameters and calibration set up.	<b>Table 19</b>
<b>READ STATUS</b>	Display operating and alarm status. Display self-test diagnostic results.	<b>Table 20</b>
<b>SET DRVINF</b>	Display and/or set various parameters specific to the actuator.	<b>Table 21</b>

---

<b>SET MAINT</b>	Display various operating statistics. Reset accumulated operating statistics	<b>Table 22</b>
<b>CAL POSOUT</b>	Use the display as an indicator, (in this case a voltmeter) so you can verify that the position sensor is operating properly.	<b>Table 23</b>

---

## Set Up Procedure

Each of the set up groups and their functions are either pre-configured at the factory or set to their default values. Tables 8 through 19 list and describe the options available in each set up group. The following procedure shows you the key press sequence to access any set up group or any associated Function parameter. Make sure lock set up group “LOCK” function is set to “NONE” or “CAL.” Also some parameters require that you enter a security password before you access or change the parameter.

**You can use this procedure to access the set up groups and select all parameters.**

**Table 9 Set Up Procedure Using Display and Keypad**

Step	Operation	Press	Result
1	Enter Set Up Mode	SET UP	<p><i>Upper Display</i> = <b>SET</b></p> <p>Lets you know you are in the set up mode and a set up group title is being displayed in the lower display.</p> <p><i>Lower Display</i> = <b>INPUT</b></p> <p>This is the first set up group you see when you press SET UP.</p>
2	Select any Set Up Group	SET UP	<p>Successive presses of the SET UP key will display the other set up group titles as listed in Table 8 <b>Error! Reference source not found.</b></p> <p>You can also use the ▲ or ▼ keys to scroll through the set up groups in both directions.</p> <p>Stop at the set up group title that describes the group of parameters you want to configure. Then proceed to the next step.</p>
3	Select a Function Parameter	FUNCTION	<p><i>Upper Display</i>  <div style="border: 1px solid black; display: inline-block; padding: 2px;">4-20</div> Shows the current value or selection for the function prompt in the selected set up group.</p> <p><i>Lower Display</i>  <div style="border: 1px solid black; display: inline-block; padding: 2px;">IN TYP</div> Shows the first function prompt within the selected set up group.</p> <p>Example display shows Input group function prompt “IN TYP” and the selection.</p>
4	Select other function parameters	FUNCTION	<p>Successive presses of the FUNCTION key will sequentially display the other function prompts of the selected set up group.</p> <p>Stop at the function prompt that you want to change, and then proceed to the next step.</p>

Step	Operation	Press	Result
<b>5</b>	Change the Value or Selection	▲ or ▼	<p>These keys increase or decrease the value, or display the next available selection for the selected function prompt.</p> <p>See Table 7, <i>Set Up Tips</i> for instructions to increase or decrease a value quickly.</p> <p>Change the value or selection to meet your needs.</p> <p>NOTE: If the display flashes, you are trying to make an unacceptable entry, or the value on the display is at its range limit. The display may also show "KEYERR" (Key error).</p>
<b>6</b>	Enter Value or Selection	FUNCTION or SET UP	<p>This key selects another function prompt.</p> <p>This key selects another set up group.</p> <p>NOTE: Pressing either key will cause the previously selected value or selection to be entered into memory.</p>
<b>7</b>	Exit Set Up mode	DISPLAY	<p>Exits set up mode and returns actuator to the same state it was in immediately preceding entry into the set up mode. Any changes you have made are stored in memory.</p> <p>If you do not press any keys for 30 seconds, the display times out and reverts to the mode and display shown prior to entering the set up mode.</p>

---

## Configuration Prompt Hierarchy

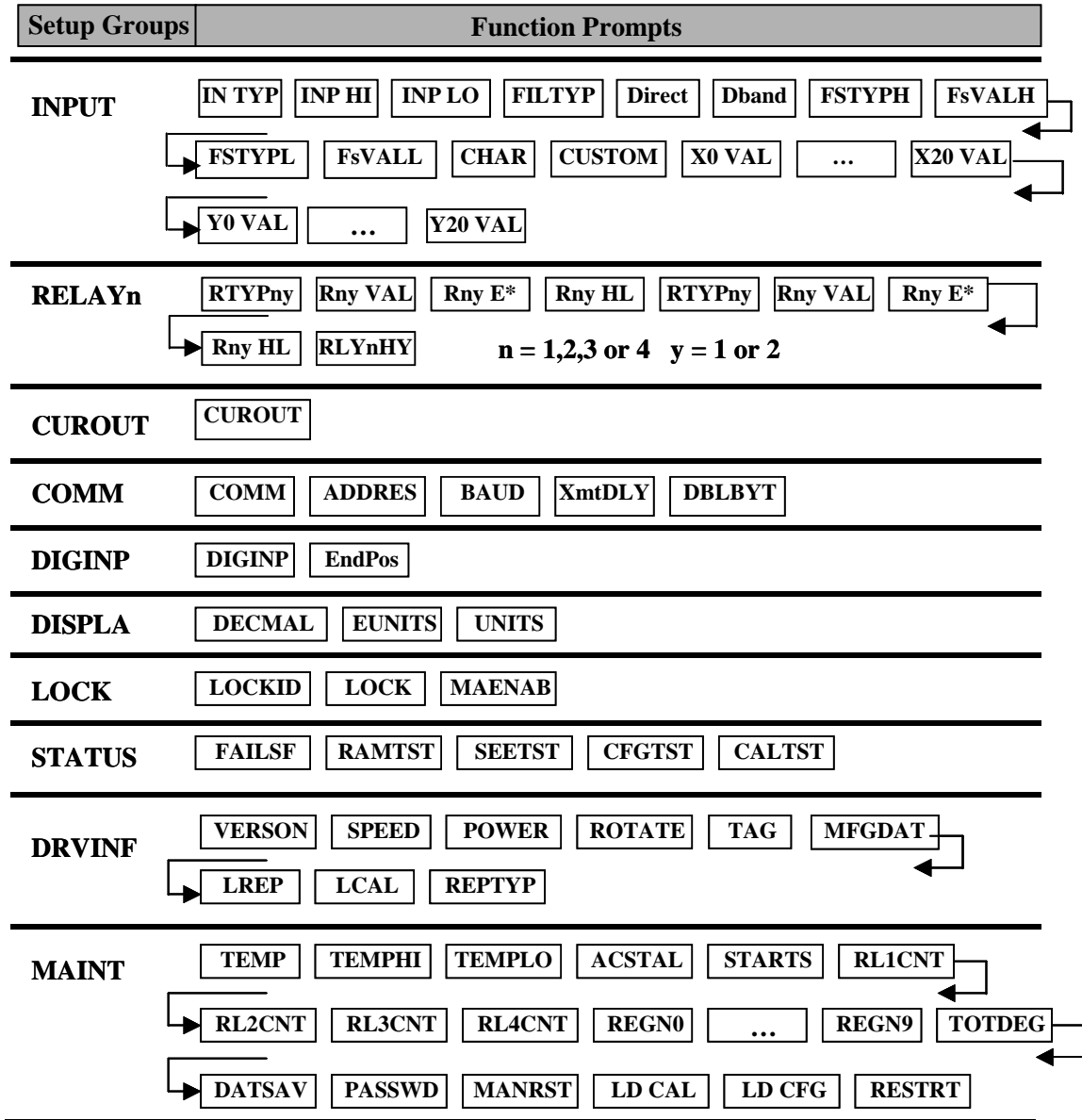

## Input Set Up Group

Table 10 lists the parameters and selections available when the SET INPUT group is selected.

On the keypad and local display:

- Press the SET UP key to enter the Input Set Up group.
- Press the FUNCTION key to scroll through the prompts listed in the set up group.
- Press the ▲ or ▼ keys to view selections or change range settings.

**Table 10 Input Set Up Group Parameters**

Actuator Lower Display Prompt	Selections or Range of Setting	Parameter Definition/PDA HercuLink Prompt
<p><b>IN TYP</b></p> <p><b>Note:</b> If input type from model selection guide is: 0/4-20mA, 0/1-5Vdc, 0-10Vdc</p>	<p><b>4-20</b> <b>0-20</b> <b>1-5V</b> <b>0-5V</b> <b>0-10</b> <b>R_SP</b></p>	<p><b>INPUT ACTUATION TYPE</b>— This selection specifies the signal type and range you are going to use for the actuator input. Be sure that the values configured for the high and low range, alarm setpoint, etc. are within the measuring range for the selected signal range.</p> <p><b>4 to 20 mA</b> <b>0 to 20 mA</b> <b>1 to 5 Volts dc</b> <b>0 to 5 Volts dc</b> <b>0 to 10 Volts dc</b> <b>Remote Setpoint</b> (via communications)</p> <p>NOTE: Changing the Input Actuation Type will restore the actuator calibration to its factory values.</p>
<p><b>IN TYP</b></p>	<p><b>S_90</b></p>	<p><b>Series 90</b> – 0 to 135 ohms.</p> <p>Note: If input type from model selection guide is: Series 90 control</p>
<p><b>INP HI</b></p>	<p><b>10.0 to 100</b></p> <p><i>default = 100</i></p>	<p><b>INPUT HIGH RANGE VALUE</b> in % is displayed.</p> <p>NOTE: When Input Type (R_SP or S_90) is selected, Input Hi is not configurable.</p>
<p><b>INP LO</b></p>	<p><b>0.0 to 90.0</b></p> <p><i>default = 0.0</i></p>	<p><b>INPUT LOW RANGE VALUE</b> in % is displayed.</p> <p>NOTE: When Input Type (R_SP or S_90) is selected, Input Hi is not configurable.</p>

Actuator Lower Display Prompt	Selections or Range of Setting	Parameter Definition/PDA HercuLink Prompt
<b>FILTYP</b>	<p><b>NONE</b></p> <p><b>SPIK</b></p> <p><b>S+LP</b></p> <p><b>LPAS</b></p> <p><i>default = LPAS</i></p>	<p><b>INPUT FILTER TYPE</b>— Allows the selection of a software digital input filter to smooth the input signal.</p> <p><b>Spike</b>— Selects spike filter to remove transients in the input signal when actuator is installed in noisy environments.</p> <p><b>Spike plus Low Pass</b>— Selects spike and low pass filtering. * Allows setting of lag time constant for low pass filter.</p> <p><b>Low Pass</b>— Selects low pass filter. * Allows setting of lag time constant.</p> <p>NOTE: When Input Type (R_SP or S_90) is selected, Input Filter Type = NONE.</p>
<b>LPFILT *</b>	<p><b>0 to 50.00</b> (in seconds)</p> <p><i>default = 0.5</i></p>	<p><b>LAG TIME CONSTANT</b>— (Filter Type S+LP or LPAS only) Allows you to set the first order lag time constant of the low pass filter when selected. Range is from 0 to 50 seconds.</p> <p>NOTE: When Input Type (R_SP or S_90) is selected, Low Pass Filter Value is not configurable.</p>
<b>Direct</b>	<p><b>CCW</b></p> <p><b>CW</b></p> <p><i>default = CCW</i></p>	<p><b>ACTUATOR ROTATION</b>—This selection determines the direction of rotation of the actuator shaft.</p> <p><b>Counterclockwise</b> rotation</p> <p><b>Clockwise</b> rotation</p> <p>NOTE: Actuator rotation is the direction of the output shaft when facing the end of the shaft and refers to the direction of rotation on increasing signal.</p>
<b>Dband</b>	<p><b>0.2 to 5.0</b> (in percent of span)</p> <p><i>default = 0.5</i></p>	<p><b>INPUT DEADBAND</b>— Specifies an adjustable gap that is the difference between the setpoint value and the value at which the motor energizes. Deadband is set in percent of full span.</p>
<b>FSFTYPH</b>	<p><b>LAST</b></p> <p><b>UP</b></p> <p><b>DOWN</b></p> <p><b>USER</b></p> <p><i>default = UP</i></p>	<p><b>FAILSAFEHI TYPE</b>—Selects the motor position you want the actuator to go to when input signal is above the high end range value.</p> <p>NOTE: Failsafe condition occurs when the input exceeds its high end range value by 3%.</p> <p><b>Last Position</b>—Actuator motor remains at last position.</p> <p><b>Up</b>—Actuator motor moves to full scale value.</p> <p><b>Down</b>—Actuator motor moves to zero value.</p> <p><b>User selected value</b>—Actuator motor moves to a customer-defined value.</p> <p>* Allows setting of failsafehi input value.</p>
<b>FsFVALH *</b>	<p><b>0 to 100%</b></p> <p><i>default = 100</i></p>	<p><b>FAILSAFEHI INPUT VALUE</b>—(FailsafeHI Type USER only) Selects the motor position you want the actuator to go to when input signal is above the high end range value. Range is from 0 to 100%.</p>



Actuator Lower Display Prompt	Selections or Range of Setting	Parameter Definition/PDA HercuLink Prompt
FSFTYPL	<p>LAST UP DOWN USER</p> <p><i>default = DOWN</i></p>	<p><b>FAILSAFELO TYPE</b>—Selects the motor position you want the actuator to go to when input signal is below the low end range value or on loss of input signal.</p> <p>NOTE: Failsafe condition occurs when the input exceeds its low end range value by 3%, or when the input signal goes to zero. For input types 0 to 20mA, 0 to 5 V, and 0 to 10 V there is no failsafe condition at the zero value.</p> <p><b>Last Position</b>—Actuator motor remains at last position.</p> <p><b>Up</b>—Actuator motor moves to full scale value.</p> <p><b>Down</b>—Actuator motor moves to zero value.</p> <p><b>User selected value</b>—Actuator motor moves to a customer-defined value.</p> <p>* Allows setting of failsafelo input value.</p>
FsFVALL *	<p>0 to 100%</p> <p><i>default = 0</i></p>	<p><b>FAILSAFELO INPUT VALUE</b>—(FailsafeLO Type USER only) Selects the motor position you want the actuator to go to when input signal is below the low end range value or on loss of input.</p> <p>Range is from 0 to 100%.</p>
CHAR	<p>LINR SQRT CUST</p> <p><i>default = LINR</i></p>	<p><b>INPUT CHARACTERIZATION</b>— Selects a characterization type that causes the actuator to characterize a linear input signal to represent a non-linear input.</p> <p><b>Linear</b>— Provides linear characterization of the input signal.</p> <p><b>Square Root</b>— Provides square root characterizations of the input signal.</p> <p><b>Custom</b>— Custom characterization. Selecting custom allows you to create a twentieth order characterization of input value (x) and associated shaft position (y).</p> <p>NOTE: Selecting CUST input characterization causes the following prompt CUSTOM to be displayed.</p>
CUSTOM	<p>EQU QUIK USER</p> <p><i>default = EQU</i></p>	<p><b>Equal percentage</b> – Sets the characterization as explained in Equal Percentage Valve Characteristic on page 42. Values are read-only.</p> <p><b>Quick opening</b> - Sets the characterization as explained in Quick Opening Valve Characteristic on page 43. Values are read-only.</p> <p><b>User-configurable</b> – Lets you create your own characterization using the following Xn VAL and Yn VAL prompts.</p>
Xn VAL n = 1 - 20	<p>0 to 100 %</p>	<p><b>Input Value</b>— as a percentage of input range. Defaults are in increments of 5%.</p>
Yn VAL n = 1 - 20	<p>0 to 100 %</p>	<p><b>Shaft Position Value</b>— as a percentage of position range. Defaults are in increments of 5%.</p>

### Equal Percentage Valve Characteristic

Table 11 contains values that approximate an equal percentage valve characteristic in the actuator. When the EQUJ custom characterization type is selected, the values in Table 11 are automatically loaded into the actuator configuration to produce the characteristic as presented in the graph. The Xn VAL is the input value as a percentage of range and Yn VAL is the characterized output (actuator shaft position) as a percentage of range.

**Table 11 Equal Percentage Valve Characteristics**

Order	Xn VAL % of Range	Yn Val % of Range	<div style="text-align: center;"> <b>Equal Percentage Valve Characterization</b> </div>
0	0	0	
1	5	0.8	
2	10	2.1	
3	15	3.2	
4	20	4.9	
5	25	6.5	
6	30	8.4	
7	35	10.7	
8	40	13.2	
9	45	15.7	
10	50	18.7	
11	55	22.6	
12	60	27.2	
13	65	33.4	
14	70	40	
15	75	46	
16	80	53.8	
17	85	63.2	
18	90	73.7	
19	95	86.2	
20	100	100	

**Quick Opening Valve Characteristic**

Table 12 contains values that approximate the characteristic of a quick opening control valve. When the QUIK custom characterization type is selected, the values in Table 12 are automatically loaded into the actuator configuration to produce the characteristic as presented in the graph. The Xn VAL is the input value as a percentage of range and Yn VAL is the characterized output (actuator shaft position) as a percentage of range.

**Table 12 Quick Opening Valve Characteristic**

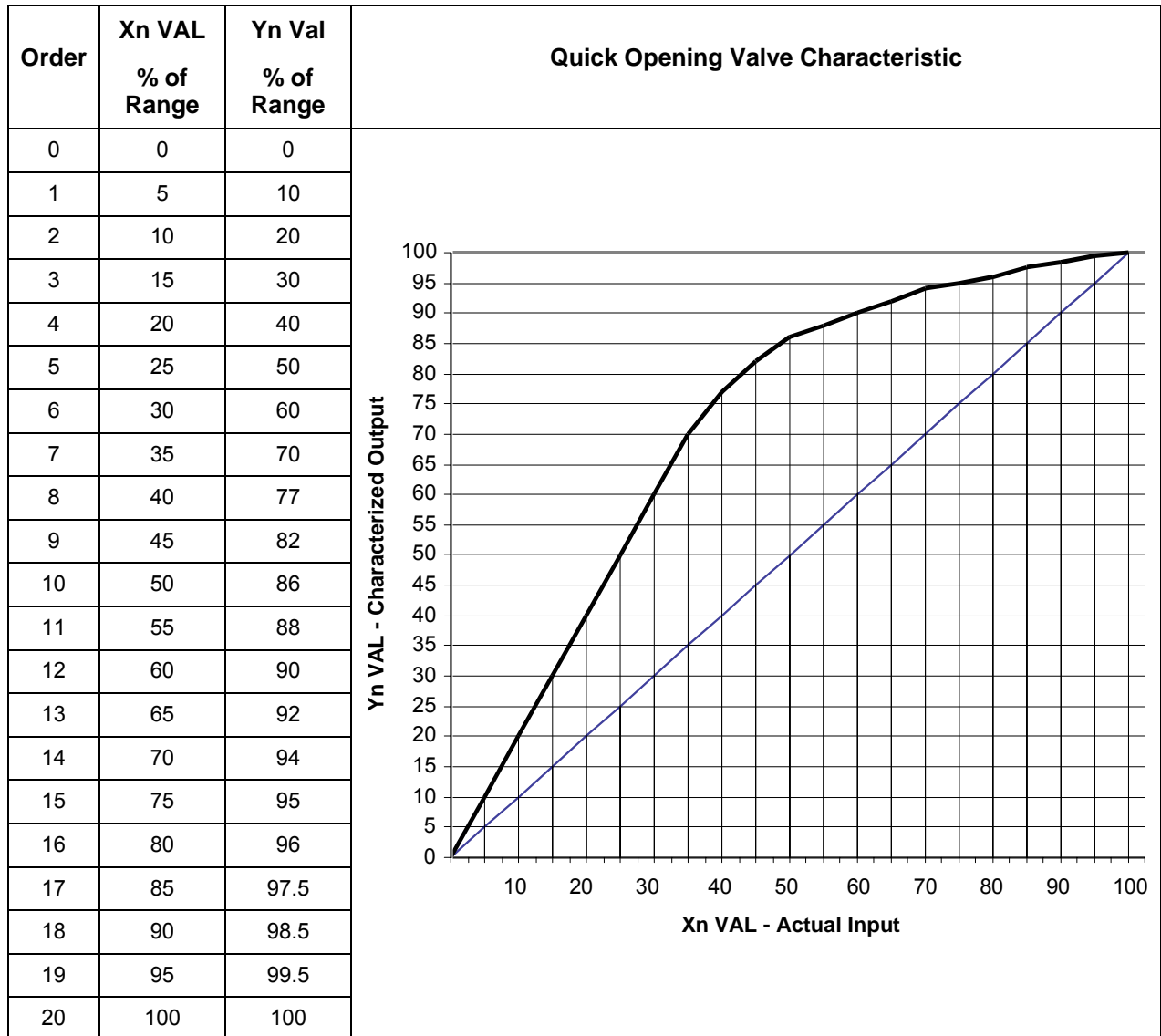

## Relays Set Up Group



### ATTENTION

The Relay set up group parameters are accessible only if relay PWAs are installed in the actuator. HercuLine® 2001 actuators can be equipped with one PWA –for a total of two SPDT relays. Using the Relay set up groups you can program the installed relays to operate in response to various operating conditions.

Table 13 lists the parameters and selections available when the SET RELAY $n$  group is selected.

**Table 13 Relay Set Up Group Parameters**

Actuator Lower Display Prompt	Selections or Range of Setting	Parameter Definition/PDA HercuLink® Prompt
<b>R<math>TYP_n</math></b> $n = 1, 2, 3, \text{ or } 4$ $y = 1 \text{ or } 2$	<b>NONE</b>  <b>InPR</b> <b>PosR</b>  <b>DEV</b> <b>ULim</b> <b>LLim</b> <b>T Hi</b> <b>T Lo</b> <b>STRT</b>  <b>STAL</b> <b>MAN</b> <b>PWRF</b> <b>FsFA</b> <b>PosF</b>  <b>DiGI</b> <b>TDEG</b> <i>default = InPR and NONE</i>	<b>RELAY TYPE</b> — Selects the relay number and the relay activation type. See Table 14 Relay Type Descriptions. <b>Input Range</b> — Upper / lower limits of input signal exceeded <b>Position Range</b> — Upper / lower limits of motor position exceeded <b>Deviation</b> — Deviation from input exceeded <b>Upper Limit Travel</b> — Same as PosR for upper limit <b>Lower Limit Travel</b> — Same as PosR for lower limit <b>Temperature High</b> — High temperature limit exceeded <b>Temperature Low</b> — Low temperature limit exceeded <b>Starts</b> — Motor starts limit exceeded. Allows setting of multiplier value. <b>Stalled</b> — Motor position does not follow input <b>Manual</b> — Actuator is set to manual mode <b>Power Up Test Failure</b> — Failure of any power up diagnostic <b>Failsafe Alarm</b> — Failsafe condition detected <b>Position Sensor Signal Failure</b> — position output out of valid range <b>Digital Input</b> — Digital input closure <b>Total Degrees</b> — total degrees traveled. Allows setting of multiplier value.
<b>R<math>nyE^*</math></b>	<b>X1</b> <b>X10k</b> <i>default = X1</i>	<b>MULTIPLIER</b> — (Relay Types STRT and TDEG only) Selects the multiplier for the number limit of motor starts and total degrees traveled before the relay is activated. Multiplier specifies the value on display as times one (X1) or times ten thousand (X10k).
<b>R<math>nyVAL</math></b> $n = 1, 2, 3, \text{ or } 4$ $y = 1 \text{ or } 2$	<b>0.0 to 100.0</b>	<b>RELAY VALUE</b> — Sets numerical value of limit where relay trips (energizes). Units are determined by the relay type selection. See Table 14 Relay Type Descriptions for units.
<b>R<math>nyHL</math></b> $n = 1, 2, 3, \text{ or } 4$ $y = 1 \text{ or } 2$	<b>HI</b> <b>LO</b>	<b>RELAY HIGH/LOW</b> — Sets relay trip point to high or low limit.
<b>R<math>LY_nHY</math></b> $n = 1, 2, 3, \text{ or } 4$	<b>0.0 to 100.0</b> (in percent)	<b>RELAY HYSTERESIS</b> — 0.0 to 100.0% of span or full output. NOTE: Relay Hysteresis parameter is accessible only if appropriate relay type is selected.

$n$  is the relay number,  $y$  is the relay contact.

**Table 14 Relay Type Descriptions**

When this Relay Type is selected... (RTYP)	The Relay can be set up to indicate ...
<b>Input Range</b>	The upper / lower limits of the input signal have been exceeded. Relay value parameter defines range limits and units are in percent of full span.
<b>Position Range</b>	Upper / lower limits of motor position have been exceeded. Relay value parameter defines range limits and units are in either percent of span or degrees of rotation. See "Relay Examples" for setting range limits.
<b>Deviation</b>	Motor position has exceeded deviation limit from input. (Deviation is defined as: setpoint – motor position = Deviation) Relay value parameter defines limits and units are in percent of span. See "Relay Examples" for setting deviation limit.
<b>Upper Limit Travel</b>	The motor position has exceeded the upper limit of travel. (Same as Position Range.) Relay value parameter defines limits and units are in degrees of rotation or percent of span. See "Relay Examples" for setting upper limit with hysteresis.
<b>Lower Limit Travel</b>	The motor position has exceeded the lower limit of travel. (Same as Position Range.) Relay value parameter defines limits and units are in degrees of rotation or percent of span.
<b>Temperature High</b>	The high temperature limit of the actuator has been exceeded. Relay value parameter defines temperature limits and units are in either degrees C or degrees F.  (Temperature units are defined in the UNITS setting of the DISPLA set up group.)
<b>Temperature Low</b>	The low temperature limit of the actuator has been exceeded. Relay value parameter defines temperature limits and units are in either degrees C or degrees F.  (Temperature units are defined in the UNITS setting of the DISPLA set up group.)
<b>Starts</b>	The accumulated motor starts have exceeded the limit. Relay value parameter defines the limit. See "Relay Examples" for setting motor starts limit. Range is from 10 to 99,990,000.
<b>Stall</b>	The motor is in a stall condition.
<b>Manual Mode</b>	The actuator is in manual mode.
<b>Power Up Test Failure</b>	A failure of any one of the power up test diagnostics. See READ STATUS set up group.
<b>Failsafe</b>	The actuator is in failsafe. (input signal loss or input signal out of valid range)
<b>Position Sensor Failure</b>	The potentiometer or non-contact sensor output is out of range or has failed.
<b>Digital Input</b>	The digital input closure.
<b>Total Degrees</b>	The total degrees traveled.

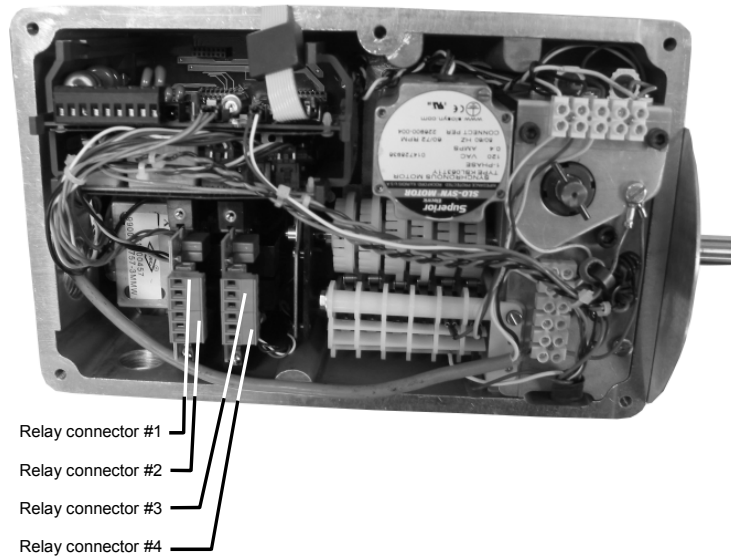

**Figure 22 Relay connectors**

**Relay Examples**

**Relay Type - Position Range**

Selecting PosR relay type, you can cause the relay to energize when the actuator motor travels below 20% of range and above 80% of range. Note in the example below that Relay 1 is set up to provide two trip points. The first trip point (R11VAL) causes the relay to energize when the motor travels above 80%, the second trip point (R12VAL) is set so the relay energizes when the motor travels below 20%.

Set Up Group	Parameter	Value
SET RELAY1	RTYP11	PosR
	R11VAL	80.0
	R11HL	HI
	RTYP12	PosR
	R12VAL	20.0
	R12HL	LO
	RLY1HY	0.0

The figure below shows the resulting action.

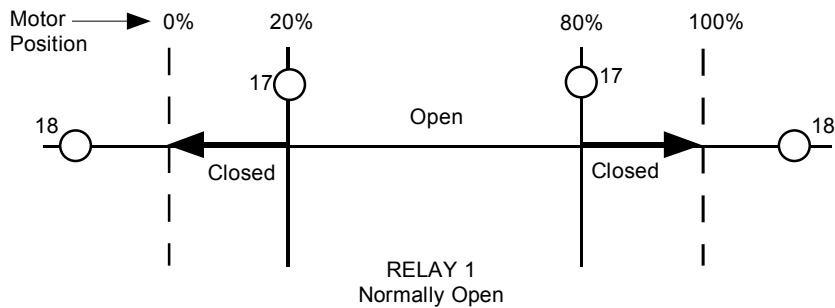

**Relay Type - Deviation**

Setting up a relay to alarm (energize) when the motor position deviates 10% (+ or -) from the actuator setpoint can be set up as follows.

Set Up Group	Parameter	Value
SET RELAY1	RTYP11	DEV
	R11VAL	10.00
	R11HL	HI
	RTYP12	DEV
	R12VAL	-10.00
	R12HL	LO
	RLY1HY	0.0

The resulting action is shown below.

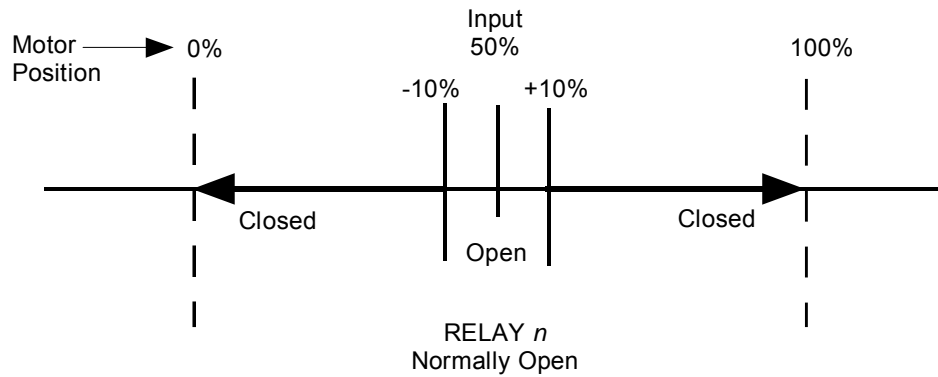

**Relay Type – Upper Limit Travel with Hysteresis**

Selecting relay type ULim will cause the relay to energize when the motor position exceeds the upper limit trip point, and can be set up as follows. Note that relay hysteresis parameter (RLY1HY) value is set to 10, which is 10% of range. This means that when the relay is energized, due to the motor position exceeding the upper limit value, the relay will not de-energize until the motor moves to 10% below the trip point.

Set Up Group	Parameter	Value
SET RELAY2	RTYP21	ULim
	R21VAL	70.0
	R21HL	HI
	RTYP22	NONE
	RLY2HY	10.0

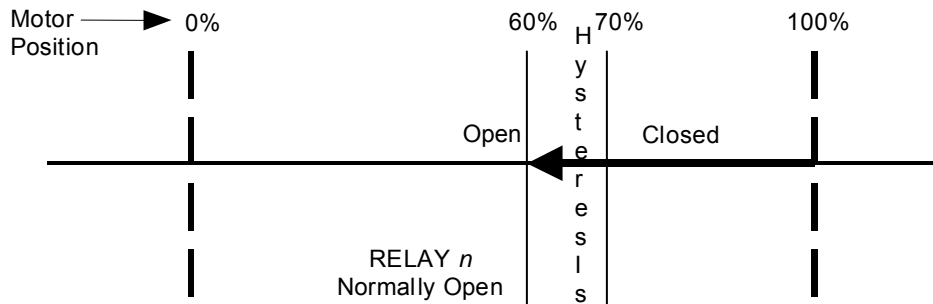
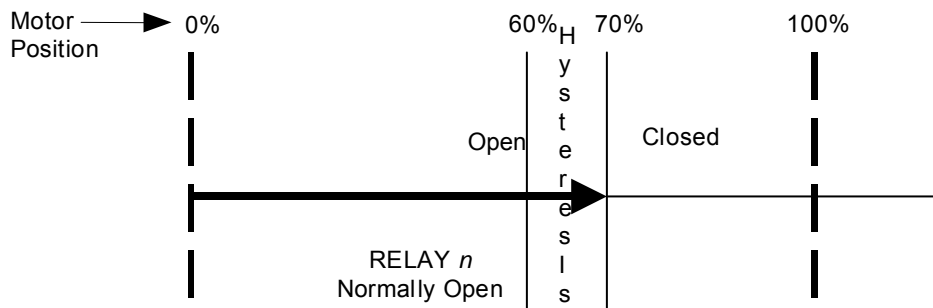

**Relay Type – Motor Starts**

Selecting relay type STRT will cause the relay to trip when the number of motor starts exceeds the selected limit. The motor starts value is stored as one of the maintenance group statistics. This example sets the motor starts limit at 200,000 for Relay 1.

Set Up Group	Parameter	Value
SET RELAY1	RTYP11	STRT
	R11 E*	X10K
	R11VAL	20
	R11HL	HI
	RTYP12	NONE

The resulting action is that Relay 1 will trip when the number of accumulated motor starts in the maintenance group exceeds 200,000.



## Current Out Set Up Group

Table 15 lists the parameters and selections available for the SET CUROUT group.

**Table 15 Current Out Set Up Group Parameters**

Actuator Lower Display Prompt	Selections or Range of Setting	Parameter Definition/PDA HercuLink Prompt
<p><b>CUROUT</b></p> <p><b>Note:</b> If output type from model selection guide is: 0/4-20mA, 0/1-5Vdc</p>	<p><b>4 – 20</b> <b>0 – 20</b> <b>1 – 5V</b> <b>0 – 5V</b></p>	<p><b>OUTPUT SIGNAL RANGE</b>— Selects the signal output range.</p> <p><b>4 to 20 mA</b> <b>0 to 20 mA</b> <b>1 to 5 Volts (250 ohm resistor required)</b> <b>0 to 5 Volts (250 ohm resistor required)</b></p>
<p><b>CUROUT</b></p> <p><b>Note:</b> If output type from model selection guide is: Slidewire Emulation</p>	<p><b>SW E</b></p>	<p><b>Slidewire Emulation</b></p>
<p><b>CUROUT</b></p> <p><b>Note:</b> If output type from model selection guide is: None</p>	<p><b>NONE</b></p>	<p><b>No current output configured.</b></p>

## Communications Set Up Group

Table 16 lists the parameters and selections available for the SET COMM group.

**Table 16 Communications Set Up Group Parameters**

Actuator Lower Display Prompt	Selections or Range of Setting	Parameter Definition/PDA Herculink Prompt										
<b>COMM</b>	<p><b>DIS</b></p> <p><b>MODB</b></p> <p><b>HART</b></p>	<p><b>COMMUNICATONS PARAMETERS</b>— Disables or enables parameter displays for Modbus communications set up.</p> <p><b>Disabled</b>— Locks out access to communications displays and parameters.</p> <p><b>Modbus</b>— Allows access to the communication displays and settings for the parameters listed below.</p> <p><b>HART</b> – selects HART as the communications protocol</p>										
<b>ADDRES</b>	<p><b>1 to 99</b></p> <p><i>default = 1</i></p>	<b>DEVICE ADDRESS</b> — Selects device address when used in a Modbus communications loop. Select an address that is unique to other devices on the communications link.										
<b>BAUD</b>	<p><b>2400</b></p> <p><b>4800</b></p> <p><b>9600</b></p> <p><b>19.2k</b></p> <p><i>default = 19.2k</i></p>	<b>BAUD RATE</b> — Selects the speed of data transfer. All equipment on the link must be set to match the host setting.										
<b>XmtDLY</b>	<p><b>NONE</b></p> <p><b>10ms</b></p> <p><b>20ms</b></p> <p><b>30ms</b></p> <p><b>40ms</b></p> <p><b>50ms</b></p> <p><i>default = 20ms</i></p>	<b>RESPONSE DELAY</b> — Selects the time delay (in milliseconds) before a response to a query is transmitted.										
<b>DBLBYT</b>	<p><b>FP B</b></p> <p><b>FPBB</b></p> <p><b>FP L</b></p> <p><b>FPLB</b></p> <p><i>default = FP B</i></p>	<p><b>FLOATING POINT DATA FORMAT</b>— Selects the format for transferring floating point data.</p> <table style="width: 100%; border: none;"> <thead> <tr> <th></th> <th style="text-align: right;"><b>Byte Order</b></th> </tr> </thead> <tbody> <tr> <td><b>Floating Point Big Endian format</b>—</td> <td style="text-align: right;">0 1 2 3</td> </tr> <tr> <td><b>Floating Point Big Endian format</b> with byte-swapped—</td> <td style="text-align: right;">1 0 3 2</td> </tr> <tr> <td><b>Floating Point Little Endian format</b>—</td> <td style="text-align: right;">3 2 1 0</td> </tr> <tr> <td><b>Floating Point Little Endian format</b> with byte-swapped—</td> <td style="text-align: right;">2 3 0 1</td> </tr> </tbody> </table>		<b>Byte Order</b>	<b>Floating Point Big Endian format</b> —	0 1 2 3	<b>Floating Point Big Endian format</b> with byte-swapped—	1 0 3 2	<b>Floating Point Little Endian format</b> —	3 2 1 0	<b>Floating Point Little Endian format</b> with byte-swapped—	2 3 0 1
	<b>Byte Order</b>											
<b>Floating Point Big Endian format</b> —	0 1 2 3											
<b>Floating Point Big Endian format</b> with byte-swapped—	1 0 3 2											
<b>Floating Point Little Endian format</b> —	3 2 1 0											
<b>Floating Point Little Endian format</b> with byte-swapped—	2 3 0 1											

## Digital Input Set Up Group

Table 17 lists the parameters and selections available for the SET DIGINP group.

**Table 17 Digital Input Set Up Group Parameters**

Actuator Lower Display Prompt	Selections or Range of Setting	Parameter Definition/PDA HercuLink® Prompt
<b>DIGINP</b>	<p><b>NONE</b></p> <p><b>UP</b></p> <p><b>DOWN</b></p> <p><b>USER</b></p> <p><i>default = UP</i></p>	<p><b>Digital Input State</b>— Selects the position of the actuator in response to a digital input signal (contact closure).</p> <p><b>None</b>— No action by the actuator.</p> <p><b>Up</b>— Actuator motor moves to full scale value.</p> <p><b>Down</b>— Actuator motor moves to zero value.</p> <p><b>User selected value</b>— Actuator motor moves to a customer-selected value. * Allows setting of End Position Value.</p>
<b>EndPos</b>	<b>0 – 100</b> (in percent)	<b>END POSITION VALUE</b> — (DIGINP USER only) Selects the motor position you want the actuator to go to when digital input signal present (contact closure).

## Display Set Up Group

Table 18 lists the parameters and selections available for the SET DISPLAY group.

**Table 18 Display Set Up Group Parameters**

Actuator Lower Display Prompt	Selections or Range of Setting	Parameter Definition/PDA Herculink® Prompt
<b>DECMAL</b>	<p><b>8888</b></p> <p><b>888.8</b></p> <p><i>default = 8888</i></p>	<p><b>DECIMAL POINT LOCATION</b>— This selection determines where the decimal point appears in the display.</p> <p><b>None</b></p> <p><b>One Place</b></p> <p>Note: Be sure the selection agrees with the value to be displayed. If display value requires 4 whole digits, the decimal will not show.</p>
<b>EUNITS</b>	<p><b>PCNT</b></p> <p><b>DEG</b></p> <p><i>default = PCNT</i></p>	<p><b>UNITS DISPLAY</b>— Selects the units of the position display.</p> <p><b>Percent</b>— Shows actuator position as a percentage of span. (0 to 100%)</p> <p><b>Degrees</b>— Shows the actuator position in degrees of rotation. (0 to 150°) (90°)</p>
<b>UNITS</b>	<p><b>SI</b></p> <p><b>ENGL</b></p> <p><i>default = ENGL</i></p>	<p><b>DISPLAY UNITS</b>— Selects standard for unit values for the local display.</p> <p><b>SI</b>— Display will show unit values in international (metric) units. (Temperature in degrees C, Date format: <i>ddmmyy</i>)</p> <p><b>English</b>— Display will show unit values in U.S. units. (Temperature in degrees F, Date format: <i>mmddyy</i>)</p>

## Lock Set Up Group

Table 19 lists the parameters and selections available for the SET LOCK group.

**Table 19 Lock Set Up Group Parameters**

Actuator Lower Display Prompt	Selections or Range of Setting	Parameter Definition/PDA HercuLink® Prompt
<b>LOCKID</b>	0 to 4095  <i>default = 0</i>	<b>PASSWORD LOCK</b> — 4-digit password can be selected to provide security access to calibration information, set up parameters and supervisory functions. Password can be a number from 0 to 4095.
<b>LOCK</b>	<b>NONE</b>  <b>CAL</b>  <b>CONF</b>  <b>FULL</b>  <i>default = NONE</i>	<b>LOCK OUT FEATURE</b> — Selects lockout security for calibration and supervisory functions, and set up groups.  <b>None</b> — No lockout of any calibration or set up groups. You select and change set up group values, and perform field calibration.  <b>Calibration</b> — Lockout for calibration groups SET CALINP, SET CALMTR, SET CALOUT and CAL POSOUT only. You can select and change set up group values.  <b>Configuration</b> — Lockout for calibration groups and set up group configuration. You can only scroll through and view set up group values.  <b>Full</b> — Lockout for calibration and all set up group values. Only SET LOCK and READ STATUS groups are accessible.
<b>MAENAB</b>	<b>DIS</b>  <b>ENAB</b>  <i>default = ENAB</i>	<b>Manual / Auto</b> — Allows the ability to lockout mode changes from the front panel.  <b>Disabled</b> — Disables the front panel auto / manual switch functionality.  <b>Enabled</b> — Enables the front panel auto / manual switch functionality.

## Set/Change Password

A password is required to disable the ability to readily change features of the actuator. Lock out of calibration capability and other supervisory functions can be controlled by using a password. The password can be any number from 0 to 4095. The password is set and/or changed by using the keys on the keypad and the local display. Follow the steps below to change the password.

NOTE: The LOCK parameter must be set to NONE in order to change the password.

Step	Action
1	Press SET UP key until the display reads SET LOCK.
2	Press the FUNCTION key until the lower display reads LOCK.  If the prompt in the upper display is flashing, a password is required to change the LOCK type, proceed to step 3.  If the upper display is not flashing and you want to change the LOCK type, proceed to step 5.  If the upper display is not flashing and you want to change the password proceed to step 3.
3	Press the FUNCTION key until the lower display reads LOCKID.
4	The upper display will show 0 (zero). Use the ▲ or ▼ keys to increment the number to the correct password. See NOTE below on use of keys.  Note: If the password can not be recovered to allow user access, a universal password can be obtained by calling the Honeywell Tactical Assistance center.
5	Press the FUNCTION key, the lower display should read LOCK. The upper display should not be flashing. If it is repeat steps 3 & 4.
6	Use the ▲ or ▼ keys to change the LOCK type to the desired selection.  If your not changing the password proceed to step 9.  If your changing the password set the LOCK type to NONE and proceed to step 7.
7	Press the FUNCTION key until the lower display reads LOCKID.
8	The upper display will show 0 (zero). Use the ▲ or ▼ keys to increment the number to the new password. See NOTE below on use of keys.
9	Press FUNCTION key to view next parameter. Press DISPLAY to exit set up mode.  (LOCK type has now been changed or Password is now set to new value).

NOTE: When changing the value of the number, you can adjust a more significant digit in the upper display by holding in one key ▲ or ▼ and pressing the other ▲ or ▼ at the same time.

The adjustment will move one digit to the left.

Press the key again and you will move one more digit to the left.

## Read Status Set Up Group

Table 20 lists the parameters and selections available for the READ STATUS group.

**Table 20 Read Status Set Up Group Parameters**

Actuator Lower Display Prompt	Selections or Range of Setting	Parameter Definition/PDA HercuLink® Prompt
<b>FAILSF</b>	<b>NO</b> <b>YES</b>	<b>FAILSAFE</b> — <i>Read Only</i> . Shows whether actuator in failsafe. <b>No</b> — Actuator not in failsafe. <b>Yes</b> — Actuator in failsafe, see Troubleshooting (page 105)
<b>RAMTST</b>	<b>PASS</b> <b>FAIL</b>	<b>RAM TEST DIAGNOSTIC</b> — <i>Read Only</i> . Shows status of RAM test diagnostic. <b>Pass</b> — Test passed, no errors <b>Fail</b> — Test failed, see see Troubleshooting (page 105)
<b>SEETST</b>	<b>PASS</b> <b>FAIL</b>	<b>SERIAL EEPROM TEST DIAGNOSTIC</b> — <i>Read Only</i> . Shows status of serial electrically erasable PROM test diagnostic. <b>Pass</b> — Test passed, no errors <b>Fail</b> — Test failed, see Troubleshooting (page 105)
<b>CFGTST</b>	<b>PASS</b> <b>FAIL</b>	<b>CONFIGURATION TEST DIAGNOSTIC</b> — <i>Read Only</i> . Shows status of Configuration test diagnostic. <b>Pass</b> — Test passed, no errors <b>Fail</b> — Test failed, see Troubleshooting (page 105)
<b>CALTST</b>	<b>PASS</b> <b>FAIL</b>	<b>CALIBRATION TEST DIAGNOSTIC</b> — <i>Read Only</i> . Shows status of Calibration test diagnostic. <b>Pass</b> — Test passed, no errors <b>Fail</b> — Test failed, see Troubleshooting (page 105)

## Drive Set Up Group

Table 21 lists the parameters and selections available for the SET DRVINF group.

**Table 21 Drive Set Up Group Parameters**

Actuator Lower Display Prompt	Selections or Range of Setting	Parameter Definition/PDA Herculink® Prompt
<b>VERSON</b>	<i>nnnn</i>	<b>FIRMWARE VERSION</b> — <i>Read Only</i> . Displays the firmware version currently in use by the actuator's CPU.
<b>SPEED</b> (150° @ 60hz)	<b>6 S</b> <b>12 S</b> <b>25 S</b> <b>50 S</b> <b>75 S</b>	<b>STROKE SPEED</b> — <i>Read Only</i> . The speed is the number of seconds it takes for the actuator shaft to move its full range of travel.
<b>SPEED</b> (90° @ 60hz)	<b>3.2 S</b> <b>7.2 S</b> <b>15 S</b> <b>30 S</b> <b>45 S</b>	<b>STROKE SPEED</b> — <i>Read Only</i> . The speed is the number of seconds it takes for the actuator shaft to move its full range of travel.
<b>SPEED</b> (150° @ 50hz)	<b>7.5 S</b> <b>15 S</b> <b>30 S</b> <b>60 S</b> <b>90 S</b>	<b>STROKE SPEED</b> — <i>Read Only</i> . The speed is the number of seconds it takes for the actuator shaft to move its full range of travel.
<b>SPEED</b> (90° @ 50hz)	<b>4.5 S</b> <b>9 S</b> <b>18 S</b> <b>36 S</b> <b>54 S</b>	<b>STROKE SPEED</b> — <i>Read Only</i> . The speed is the number of seconds it takes for the actuator shaft to move its full range of travel.
<b>POWER</b>	<b>1206</b> <b>1205</b> <b>2206</b> <b>2205</b>	<b>POWER INPUT VOLTAGE AND FREQUENCY</b> — <i>Read Only</i> . Selects the power input voltage and line frequency of the actuator.  <b>1206</b> — 120Volts, 60Hz <b>1205</b> — 120Volts, 50Hz <b>2206</b> — 220Volts, 60Hz <b>2205</b> — 220Volts, 50Hz
<b>ROTATE</b>	<b>90</b> <b>150</b>	<b>ROTATION</b> — Indicates the factory calibrated degrees of rotation.  <b>90</b> — Factory calibrated for 90 degrees of rotation. <b>150</b> — Factory calibrated for 150 degrees of rotation.
<b>TAG</b>	<i>nnnnnn</i>	<b>TAG NAME</b> — Selects the tag name or identifier of the actuator. Up to 6 alphanumeric characters. See "Set Tag Name" on next page.
<b>DMFG</b>	<i>mmddy *</i> or <i>ddmmy</i>	<b>MANUFACTURING DATE</b> — <i>Read Only</i> . Displays date code of manufacture for actuator.



Actuator Lower Display Prompt	Selections or Range of Setting	Parameter Definition/PDA HercuLink® Prompt
LREP	<i>mmddyy</i> * or <i>ddmmyy</i>	<b>DATE OF LAST REPAIR</b> — <i>Factory set only</i> . Displays date of last repair.
LCAL	<i>mmddyy</i> * or <i>ddmmyy</i>	<b>DATE OF LAST FACTORY CALIBRATION</b> — <i>Factory set only</i> . Displays date of last factory calibration
REPTYP	<p><b>NONE</b></p> <p><b>01</b></p> <p><b>02</b></p> <p><b>03</b></p> <p><b>04</b></p> <p><b>05</b></p> <p><b>06</b></p> <p><b>07</b></p> <p><b>08</b></p> <p><b>09</b></p> <p><b>10</b></p> <p><b>11</b></p> <p><b>12</b></p> <p><b>13</b></p>	<p><b>REPAIR TYPE</b>— <i>Factory set only</i>. Displays a repair code to identify the type of repair service previously performed.</p> <p><b>None</b></p> <p><i>Future</i></p> <p><b>Non-contact Sensor</b></p> <p><b>Main CPU PWA repair</b></p> <p><b>Motor service</b></p> <p><b>Power Distribution PWA service</b></p> <p><b>Switch repair</b></p> <p><b>Relay service</b></p> <p><b>Gear service</b></p> <p><b>Service to repair water damage</b></p> <p><b>Service to repair damage caused by heat</b></p> <p><b>Service to repair due to over-voltage damage</b></p> <p><b>Actuator reconfigured</b></p> <p><b>Warranty Repair</b></p>

\* NOTE: Date format is set by the UNITS parameter. See SET DISPLA set up group.

## Set Tag Name

The actuator tag name can be an alphanumeric name up to six characters. The tag name is set by using the keys on the keypad and the local display. Follow the steps below to set the tag name.

Step	Action
1	Press SET UP key until the display reads SET DRVINF.
2	Press the FUNCTION key until the upper display reads TAG.
3	The lower display contains six digits. A decimal point will be flashing at the leftmost digit for approximately three seconds. Then the decimal point shifts to the right and flashes for three seconds before shifting again to the right. This pattern repeats continuously.
4	Set the digit to the left of the flashing decimal point. Use the ▲ or ▼ keys to scroll through the character set of 0 through 9, the letters 'a' through 'z' and the letters 'A' through 'Z'. Scroll through until the desired character is displayed.
5	Wait for the decimal point to shift to the right and then scroll through using the ▲ or ▼ keys until the next character is displayed.
6	Repeat for each character of the tag until the complete tag name is displayed.
7	Press the FUNCTION key to go to the next parameter, or press DISPLAY to exit set up mode.

## Maintenance Set Up Group

The Maintenance set up group consists of information about actuator operation accumulated through time. This information (or maintenance statistics) can be used to evaluate actuator operation and determine predicted or scheduled maintenance periods. Table 22 lists the parameters and selections available for the SET MAINTENANCE group.

Please note that maintenance statistics are written to the EEPROM every 8 hours. Therefore the statistics are saved in the event of a power interruption.

**Table 22 Maintenance Set Up Group Parameters**

Actuator Lower Display Prompt	Selections or Range of Setting	Parameter Definition/PDA HercuLink® Prompt <small>PDA users: The prompts are organized differently on your PDA's HercuLink® software. Grayed prompts are under Configuration, Maintenance. Non-grayed prompts are under Maintenance.</small>
TEMP	<i>nnnn F *</i>	<b>ACTUATOR TEMPERATURE</b> — <i>Read Only</i> . Displays the current internal temperature of the actuator.
TEMPHI	<i>nnnn F *</i>	<b>HIGH TEMPERATURE LIMIT</b> — Displays the high temperature limit of the internal actuator temperature since it was last reset.
TEMPLO	<i>nnnn F *</i>	<b>LOW TEMPERATURE LIMIT</b> — Displays the low temperature limit of the internal actuator temperature since it was last reset.
<i>hh:mm:ss †</i>	<b>ACST †</b>	<b>ACCUMULATED STALL TIME</b> — Displays the accumulated stall time of the actuator motor since it was last reset.
<b>STARTS</b>	<i>nnnn</i>	<b>ACCUMULATED MOTOR STARTS</b> — Displays the accumulated motor starts since it was last reset. Multiply displayed value times $10^5$ to get actual value. Range is 0 to 999,900,000.
<b>RLnCNT</b> <i>n = 1, 2, 3 or 4</i>	<i>nnnn</i>	<b>RELAY CYCLE COUNTS</b> — Displays the accumulated cycle counts of a relay since it was last reset. One relay cycle is when a relay is energized and deenergized. Multiply displayed value times $10^5$ to get actual value. Range is 0 to 999,900,000.
<b>REGNn</b> <i>n = 0 to 9</i>	<i>nnnn</i>	<b>ACCUMULATED MOTOR STARTS</b> — Displays the accumulated motor starts in the 1 <sup>st</sup> 10% of motor span since it was last reset. See Regions of Motor Travel (page 62). Multiply displayed value times $10^5$ to get actual value. Range is 0 to 999,900,000.
<b>TOTDEG</b>	<i>nnnn</i>	<b>TOTAL DEGREES OF MOTOR TRAVEL</b> — Displays the total number of degrees of motor travel since it was last reset. Multiply displayed value times $10^5$ to get actual value. Range is 0 to 999,900,000.

Actuator Lower Display Prompt	Selections or Range of Setting	Parameter Definition/PDA HercuLink® Prompt PDA users: The prompts are organized differently on your PDA's HercuLink® software. Grayed prompts are under Configuration, Maintenance. Non-grayed prompts are under Maintenance.
<b>DATSAV</b>	<b>DIS</b> <b>ENAB</b>	<b>MAINTENANCE DATA FORCED SAVE</b> — Allows you to manually force a save of the current maintenance data values. <b>DISABLE</b> — Forced data save is disabled. <b>ENABLE</b> — Forced data save is enabled.
<b>PASSWRD</b>	<b>nnnn</b>	<b>PASSWORD</b> — If a password has been activated, then a 4-digit password is required to enable any of the functions below.  NOTE: Password is set (or changed) from the Lock set up group.
<b>MANRST</b>	<b>NONE</b> <b>STAL</b> <b>STRT</b>  <b>REGN<sub>n</sub></b> <i>n = 0 to 9</i> <b>TEMP</b>  <b>TDEG</b>  <b>REL<sub>n</sub></b> <i>n = 1, 2, 3 or 4</i> <b>ALL</b> <b>SYST</b>  <i>default = NONE</i>	<b>MAINTENANCE STATISTIC RESET</b> — Allows reset of the following maintenance statistics:  <b>None</b> — No reset of maintenance statistics <b>Stall</b> — Resets accumulated stall time to zero. <b>Motor Starts</b> — Resets the accumulated motor start counter to zero. <b>Motor Starts in the Region</b> — Resets the selected motor span region counter to zero. <b>Temperature Statistics</b> — Resets the high / low temperature limit statistics. <b>Total Degrees</b> — Resets the total degrees of motor travel to zero. <b>Relay Counts</b> — Resets the selected accumulated relay cycle counter to zero. <b>All</b> — Resets all maintenance statistics to zero. <b>SYST</b> — Enables the system restart function.

Actuator Lower Display Prompt	Selections or Range of Setting	Parameter Definition/PDA HercuLink® Prompt PDA users: The prompts are organized differently on your PDA's HercuLink® software. Grayed prompts are under Configuration, Maintenance. Non-grayed prompts are under Maintenance.
<b>LD CAL</b>	<b>NONE</b> <b>INP</b> <b>MTR</b> <b>COUT</b> <b>ALL</b> <b>POS</b>  <i>default = NONE</i>	<b>RESTORE CALIBRATION TYPE</b> — Allows you to restore a calibration value to its factory calibration.  <b>Input</b> — Restores input calibration to the factory calibration for the current configured input type.  <b>Motor</b> — Restores motor calibration to the factory calibration.  <b>Output</b> — Restores actuator output calibration to the factory calibration for the current configured output type.  <b>All</b> — Restores input (for the type configured), motor and output (for the type configured) calibration to the factory calibration.  <b>POS</b> — Allows a position sensor field calibration to be stored as a factory calibration. This is to be used when a sensor is replaced in the field. See “ <i>Calibrate POS Output</i> ”.
<b>LD CFG</b>	<b>DIS</b> <b>ENAB</b>  <i>default = DIS</i>	<b>RESTORE DEFAULT FACTORY CONFIGURATION</b> — Allows you to restore the factory default configuration.  <b>DIS</b> — Restore disabled.  <b>ENAB</b> — Restore enabled.
<b>RESTRT</b>	<b>DIS</b> <b>ENAB</b>  <i>default = DIS</i>	<b>SYSTEM RESTART</b> — Allows you to force the system to restart.  <b>DIS</b> — Restart disabled.  <b>ENAB</b> — Restart enabled.  Note: The <b>MANRST</b> function must be set to <b>SYST</b> .

\* Temperature units are displayed in degrees C or F, and are set by the UNITS parameter. See SET DISPLA set up group.

† Note that the upper display contains the parameter name and the lower display contains the value. This is to allow for the display of hours: minutes: seconds.

## Regions of Motor Travel

The full span of motor travel can be 90° or 150° rotation. The span is divided into 10 regions of motor travel as shown in Figure 23 (regions are numbered 0 through 9). Maintenance statistics are accumulated on the total number of motor starts, as well as the total number of motor starts that occur in each region of travel. The statistics can be accessed in the maintenance set up group. The counts can also be reset to zero if desired. See the Maintenance Set Up Group for more information. The regions of travel are determined by the full span motor travel (90° or 150° rotation). If the actuator is set up to operate in a smaller range, for example between 40% and 80% of full span, the maintenance statistics will show motor starts only in regions 4 through 7.

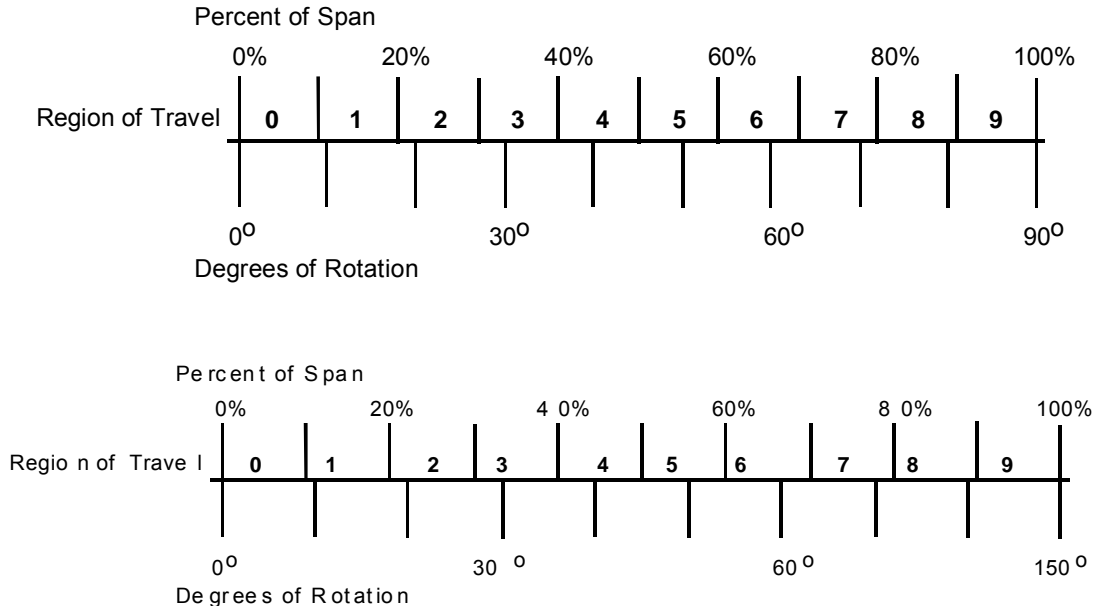

**Figure 23 Regions of Motor Travel**

## CAL POSOUT Group

The CAL POSOUT group is used to verify that the position sensor is operating and adjusted properly. This group allows the local display to indicate the output voltage of the position sensor. This display is used when verifying the POS sensor is operating and that it is properly calibrated. Table 23 shows the selections available for the CAL POSOUT group.

**Table 23 CAL POSOUT Group Parameters**

Actuator Lower Display Prompt	Selections or Range of Setting	Parameter Definition/PDA HercuLink Prompt
<b>CALPOS</b>	<i>n.nnn</i>	<b>POSITION SENSOR OUTPUT</b> — <i>Read Only</i> . Displays the output voltage of the position sensor

To access the display...

Press	Result
SETUP until you see	<i>Upper Display =</i> <i>Lower Display =</i> <b>CAL POSOUT</b>
FUNCTION	<i>Upper Display =</i> <i>Lower Display =</i> <b>DIS CALPOS</b>
▲ or ▼ key	<i>Upper Display =</i> <i>Lower Display =</i> <b>BEGN CALPOS</b>
FUNCTION	<i>Upper Display =</i> <i>Lower Display =</i> <i>n.nnn</i> (sensor output in volts) <b>POSOUT</b>

## Auto - Manual Drive Switch

The Auto - Manual switch is located on the side of the actuator case below the handwheel. The switch allows manual mode control of the actuator motor for set up, calibration and troubleshooting. Figure 24 shows an illustration of the Auto - Manual switch and Table 24 describes the switch settings. The Auto - Manual Drive switch setting overrides all input signals (analog signal and remote setpoint) and local display mode settings. When not in auto the manual LED will flash every second.

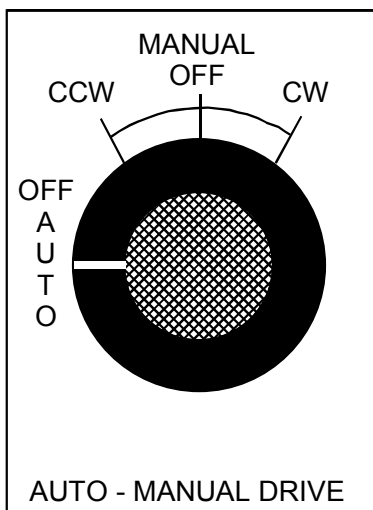

Figure 24 Auto - Manual Switch

Table 24 Auto - Manual Switch Functions

Switch Setting	Motor Drive Control
AUTO	Actuator moves according to signal input and set up configuration.
CCW	Actuator moves to the fully counterclockwise position.
CW	Actuator moves to the fully clockwise position.
OFF	Actuator is idle.



## Calibration

Calibration of the HercuLine® 2000 Series Actuator may consist of calibrating the motor circuit that positions the actuator with 0/4-20mA input signal, calibrating the potentiometer or non-contact sensor, and calibrating the slidewire emulation output or the 0/4-20mA output signal. Typically, only a motor calibration is required for installation.

Calibration is performed by connecting test equipment to the input terminals or output terminals and then using the keypad and display to step through the calibration group functions.



### ATTENTION

Input calibration and output calibrations are performed at the factory and may not be necessary. Normally, you may only need to perform Calibrate Motor.

Only qualified personnel should perform calibration.



### WARNING

High voltages exist inside the actuator case. Do not touch the powered wires inside. Death or serious injury can occur.

## Equipment Needed

The table below lists the equipment you will need to calibrate the HercuLine® 2000 input and output circuits.

Procedure	Equipment Needed
<b>Input Calibration</b>	<ul style="list-style-type: none"> <li>• A calibrated signal source which can provide current (4 to 20 mA) or voltage (0 to 10 V) with an accuracy of 0.02% or better.</li> <li>• Two insulated copper leads for connecting the current source to the actuator.</li> </ul>
<b>Output Calibration</b>	<ul style="list-style-type: none"> <li>• A digital voltmeter with an accuracy of 0.01% or better.</li> <li>• A 250 ohm resistor 0.01% tolerance.</li> </ul>

### Calibration Set up

Follow the steps below to set up the test equipment and actuator to verify calibration or perform calibration procedures.

Step	Action
1	Determine input type (current or voltage).
2	Set jumper W2 on main CPU board according to type of signal source. See Figure 27 on page 68 for jumper location.
3	Connect the copper leads from the signal source to the input terminals of the actuator as shown in Figure 25.
4	Place signal source output at zero and switch power on.
5	Connect a 250 ohm resistor across the Output terminals of the actuator and connect the DVM leads to the terminals.

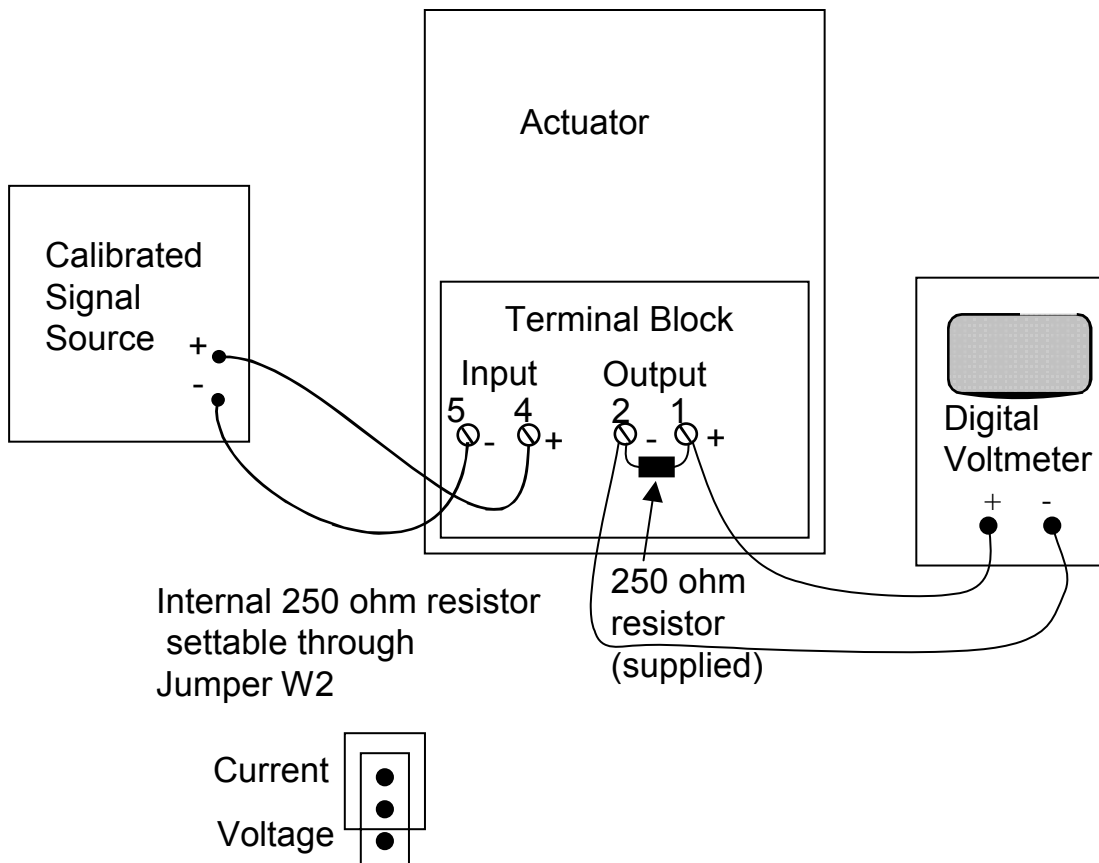

**Figure 25 Calibration Wiring Connections (non-slidewire emulation)**

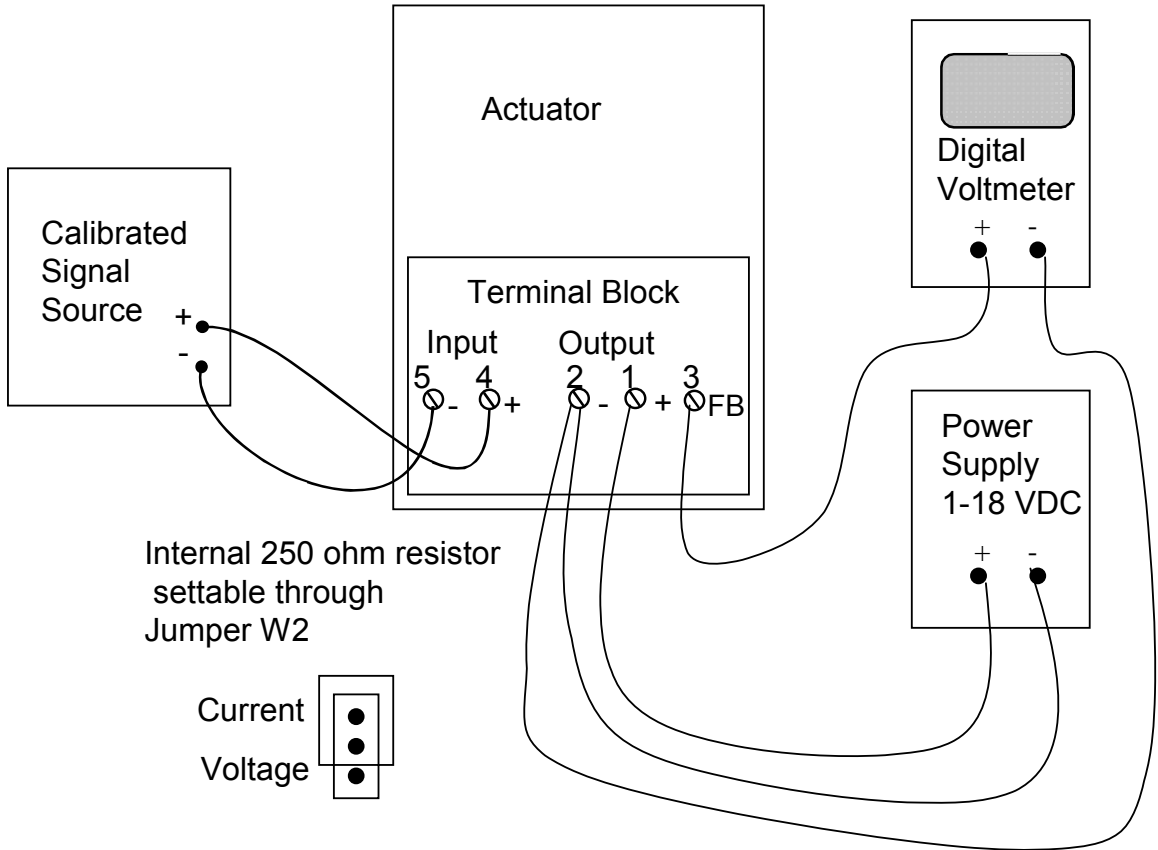
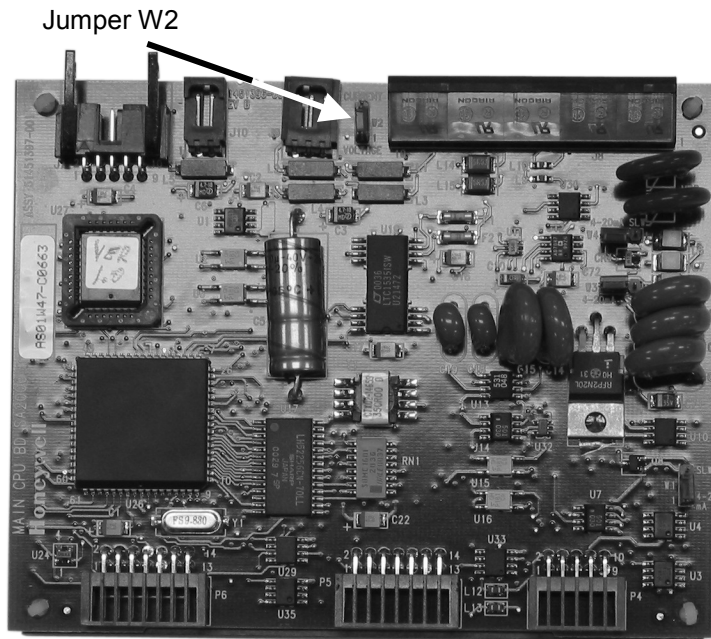

Figure 26 Calibration Wiring Connections (slidewire emulation)



**Figure 27 Jumper Location on CPU PWA**

### Calibrate Input

The HercuLine<sup>®</sup> 2001/2002 actuator accepts a variety of signal inputs.

1. 0 to 20 mA, or 4 to 20 mA
2. 0 to 5 Volts, 1 to 5 Volts, or 0 to 10 Volts

The input type is selected through the Input set up group using the local keypad.

Refer to Figure 25 for the wiring connections and follow the procedure in Table 25 to calibrate the input circuit of the HercuLine<sup>®</sup> 2001/2002 actuator.



#### **ATTENTION**

For an input calibration to be saved, you must complete the procedure. The calibration will not be saved if you exit without completing the steps of the procedure.

To exit calibration mode, press DISPLAY or SETUP keys.

---

**Table 25 Input Calibration Procedure**

Step	Operation	Press	Result
1	Enter Calibration Mode	SETUP until you see	<i>Upper Display =</i> <i>Lower Display =</i> <b>CAL INPUT</b>
		FUNCTION	<i>Upper Display =</i> <i>Lower Display =</i> <b>DIS CAL IN</b>
		▲ or ▼ key	<i>Upper Display =</i> <i>Lower Display =</i> <b>BEGN CAL IN</b>
2	Calibrate Zero (0%)	FUNCTION	<i>Upper Display =</i> <i>Lower Display =</i> <b>APLY INZERO</b> <ul style="list-style-type: none"> <li>• Adjust the signal source to an output value equal to 0% range value.</li> <li>• Wait 5 seconds, then go to step 3.</li> </ul>
3	Calibrate Span (100%)	FUNCTION	<i>Upper Display =</i> <i>Lower Display =</i> <b>APLY INSPAN</b> <ul style="list-style-type: none"> <li>• Adjust the signal source to an output value equal to 100% range value.</li> <li>• Wait 5 seconds, then go to step 4.</li> </ul>
4		FUNCTION	<i>Calibration for zero and span input values are now saved. Input calibration is complete.</i>  NOTE: The display will automatically go to the CAL MOTOR set up display. See Table 26. You may also exit calibration mode by pressing the DISPLAY or SETUP keys.  <b>ATTENTION:</b> When calibrating the motor to a short stroke range, you must reset the end-of-travel limit switches. See <i>Setting End-of-Travel Limit Switches</i> .

### Calibrate Motor

Use the procedure in Table 26 to calibrate the actuator motor for 0% and 100% input signal



#### ATTENTION

For a motor calibration to be saved, you must complete the procedure. The calibration will not be saved if you exit without completing the steps of the procedure.



#### ATTENTION

When calibrating the motor to a short stroke range, you must reset the end-of-travel limit switches. See *Setting End-of-Travel Limit Switches*.

**Table 26 Motor Calibration Procedure**

Step	Operation	Press	Result
1	Enter Calibration Mode	SETUP until you see	<i>Upper Display =</i> <i>Lower Display =</i> <b>CAL MOTOR</b>
		FUNCTION	<i>Upper Display =</i> <i>Lower Display =</i> <b>DIS CALMTR</b>
		▲ or ▼ key	<i>Upper Display =</i> <i>Lower Display =</i> <b>BEGN CALMTR</b>
2	Calibrate Zero (0%)	FUNCTION	<i>Upper Display =</i> <i>Lower Display =</i> <b>APLY MTR LO</b> <ul style="list-style-type: none"> <li>• Use the Handwheel or AUTO/MANUAL switch to manually drive the actuator motor to its low position.</li> <li>• Wait 5 seconds, then go to step 3.</li> </ul>
3	Calibrate Span (100%)	FUNCTION	<i>Upper Display =</i> <i>Lower Display =</i> <b>APLY MTR HI</b> <ul style="list-style-type: none"> <li>• Use the Handwheel or AUTO/MANUAL switch to manually drive the actuator motor to its high position.</li> <li>• Wait 5 seconds, then go to step 4.</li> </ul>
4		FUNCTION	<i>Calibration for zero and span motor positions are now saved. Motor calibration is complete.</i>  NOTE: The display will automatically go to the CAL CURENT set up display. See Table 27. You may also exit calibration mode by pressing the DISPLAY or SETUP keys.

## Calibrate Output

HercuLine<sup>®</sup> 2001/2002 actuator can be one of three output types:

1. 0 to 20 mA, or 4 to 20 mA output
2. 0 to 5 Volts, or 1 to 5 Volts with 250 ohm range resistor
3. Slidewire emulation.

The output signal range is selected through the Current Out set up group using the keypad and local display.

### 0/4-20 mA Output

The HercuLine<sup>®</sup> 2001/2002 Actuator comes already calibrated from the factory. If it becomes necessary to do a calibration in the field, adjust the output using the procedure in Table 27. Refer to Figure 25 for a diagram to connect a signal source to the actuator input and a DVM to measure actuator output signal.

This procedure provides the steps to calibrate the actuator for a 4 to 20mA output. If you are using another output type, change the procedure accordingly.



#### ATTENTION

For an output calibration to be saved, you must complete the procedure. The calibration will not be saved if you exit without completing the steps of the procedure.

To exit calibration mode, press DISPLAY or SETUP keys.

**Table 27 Output Calibration Procedure**

Step	Operation	Press	Result
1	Enter Calibration Mode	SETUP until you see	<i>Upper Display =</i> <i>Lower Display =</i> <b>CAL CUR OUT</b>
		FUNCTION	<i>Upper Display =</i> <i>Lower Display =</i> <b>DIS CALOUT</b>
		▲ or ▼ key	<i>Upper Display =</i> <i>Lower Display =</i> <b>BEGN CALOUT</b>

Step	Operation	Press	Result
2	Calibrate Zero (0%)	FUNCTION  ▲ or ▼ key	Upper Display = Lower Display =  • Read meter connected to actuator output.  • Adjust actuator output to a value equal to 0% output as read from the DVM.  NOTE: Typically for a 4 mA output, the display will show a value of approximately 382. A lower limit value is imposed on the zero output. If the value is 357 or lower, the actuator will not allow you to calibrate the zero output. The value must be larger than 357 for a valid calibration.
3	Calibrate Span (100%)	FUNCTION  ▲ or ▼ key	Upper Display = Lower Display =  • Read meter connected to actuator output.  • Adjust actuator output to a value equal to 100% output as read from the DVM.  • NOTE: Typically for a 20 mA output, the display will show a value of approximately 1887.
4		FUNCTION	Calibration for zero and span output values are now stored. Output calibration is complete.

### Slidewire Emulation

The HercuLine® 2001/2002 Actuator comes already calibrated from the factory. If it becomes necessary to do a calibration in the field, adjust the output using the procedure in Table 28. Refer to Figure 26 for a diagram to connect a signal source to the actuator input and a DVM to measure actuator output signal.



#### ATTENTION

For a slidewire emulation output calibration to be saved, you must complete the procedure. The calibration will not be saved if you exit without completing the steps of the procedure.

To exit calibration mode, press DISPLAY or SETUP keys.



**Table 28 Slidewire Emulation Calibration Procedure**

Step	Operation	Press	Result
1	Enter Calibration Mode	SETUP until you see	<i>Upper Display =</i> <i>Lower Display =</i> <b>CAL OUTPUT</b>
		FUNCTION	<i>Upper Display =</i> <i>Lower Display =</i> <b>DIS CALOUT</b>
		▲ or ▼ key	<i>Upper Display =</i> <i>Lower Display =</i> <b>BEGN CALOUT</b>
2	Calibrate Zero (0%)	FUNCTION	<i>Upper Display =</i> <i>Lower Display =</i> <b>xxx ZERO</b>  xxx = arbitrary number assigned by software
		▲ or ▼ key	Adjust actuator output voltage using down key until value on DVM ceases to change, then press up key until value on DVM moves up one digit
3	Calibrate Span (100%)	FUNCTION	<i>Upper Display =</i> <i>Lower Display =</i> <b>xxxx SPAN</b>  xxx = arbitrary number assigned by software
		▲ or ▼ key	Adjust actuator output voltage using ▲ key until value on DVM ceases to change, then press ▼ down key until value on DVM moves down one digit
		FUNCTION	Calibration for zero and span output values are now stored.  Slidewire Emulation Output Calibration is complete. Read meter connected to actuator output.

### Calibrate Position Sensor



#### ATTENTION

**The Position Sensor is factory calibrated. Under normal operation it does not require calibration.**

Sensor calibration may be necessary due to any of the following conditions:

- The sensor output is incorrect,
- The position sensor in the actuator has been replaced,
- The position sensor adjustment has been disturbed.

When the position sensor has been replaced (or serviced), you should perform a calibration of the position sensor circuit and then store it as the motor factory calibration. Please note that performing this procedure will destroy any previously stored motor factory calibration values. Table 29 outlines the steps to perform a calibration to the position sensor circuit.



While the unit is powered, a potentially lethal shock hazard exists inside the case.

**Table 29 NCS Position Sensor Calibration Procedure**

Step	Action
1	Remove AC power to the actuator.
2	Remove the six screws and the top cover from the actuator case. See Figure 2. Lay extended cover assembly on a flat surface. Remove relay cards if present.
3	Reapply AC power to the actuator.
4	Press SET UP key to access the INPUT set up group. Press FUNCTION key until the lower display reads Direct. Press the ▲ or ▼ keys to set Actuator Rotation direction to CCW. NOTE: Actuator direction must be set to CCW for this procedure. Direction can be changed after calibration is complete.
5	Drive the actuator to the 50% position (this refers to the position on the actuator scale for CCW rotation). This should be done manually with the handwheel or with the AUTO - MANUAL switch.
6	Press SET UP key until the display reads CAL POSOUT. Press the FUNCTION key until the display reads DIS CALPOS. Press the ▲ or ▼ keys until the lower display reads BEGN CALPOS. Press FUNCTION key. The upper display now shows the output of the position sensor in Volts.
7	Loosen the allen screw in the hub of the NCS spoiler just enough to be able to rotate the spoiler. See Figure 28.
8	Adjust the NCS spoiler so that the voltage in the local display is $2.500 \pm 0.010$ volts dc. The allen screw should be almost in a vertical position. The bottom edge of the spoiler should almost be horizontal in relation to the NCS PWA. See Figure 28.
9	Tighten NCS spoiler set screw with an allen wrench, holding spoilers located on each side of the NCS PWA in position. <b>IMPORTANT:</b> Spoilers need to be held in position both rotationally and longitudinally along the drive shaft extension. An air gap must be maintained between the surface of the PWA and each spoiler. (Any plastic or paper insulating material may be used to create this gap while positioning the spoilers). Make sure that neither spoiler is touching the sensor PWA when the adjustment is complete.
10	Press DISPLAY key to exit calibration mode.
11	Remove AC power to the actuator. Reinstall relay cards If present.
12	Install a new gasket and replace extended cover. Secure to actuator with screws.
13	Continue with calibration procedure in Table 31.

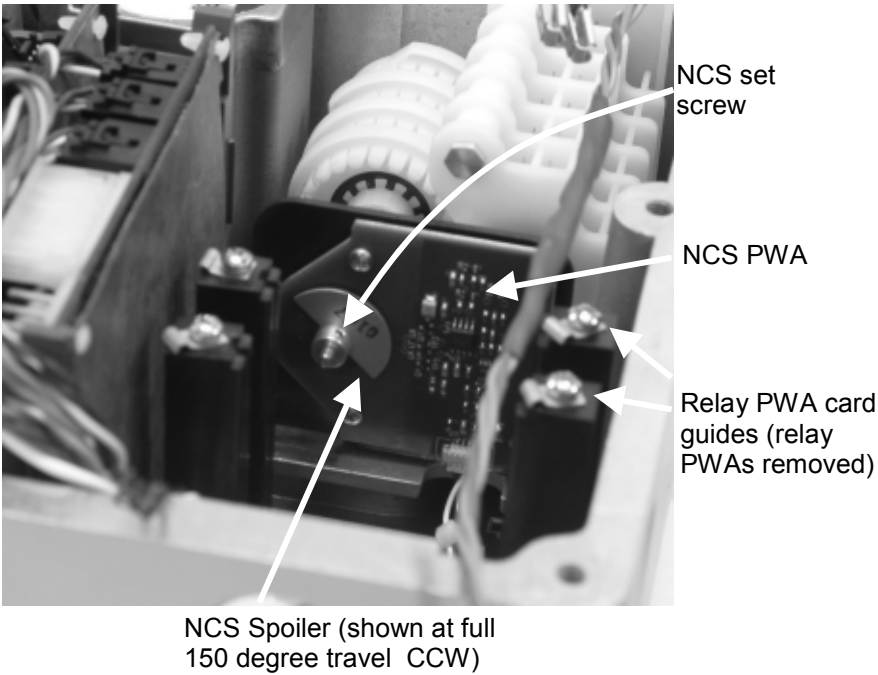

**Figure 28 Location of NCS Assembly**

**Table 30 Potentiometer Position Sensor Calibration Procedure**

Step	Action
1	Remove AC power to the actuator.
2	Remove the six screws and the top cover from the actuator case. See Figure 2. Lay extended cover assembly on a flat surface. Remove relay cards if present.
3	Reapply AC power to the actuator.
4	<p>Press SET UP key to access the INPUT set up group.</p> <p>Press FUNCTION key until the lower display reads Direct.</p> <p>Press the ▲ or ▼ keys to set Actuator Rotation direction to CCW.</p> <p>NOTE: Actuator direction must be set to CCW for this procedure. Direction can be changed after calibration is complete.</p>
5	Drive the actuator to the 50% position (this refers to the position on the actuator scale for CCW rotation). This should be done manually with the handwheel or with the AUTO - MANUAL switch.
6	<p>Press SET UP key until the display reads CAL POSOUT.</p> <p>Press the FUNCTION key until the display reads DIS CALPOS.</p> <p>Press the ▲ or ▼ keys until the lower display reads BEGN CALPOS.</p> <p>Press FUNCTION key.</p> <p>The upper display now shows the output of the position sensor in Volts.</p>
7	Loosen the set screw at the end of the switch camshaft where the potentiometer connects to the shaft.
8	Using pliers, adjust the white plastic knob on the back side of the potentiometer so the voltage in the local display is $2.500 \pm 0.010$ volts dc.
9	Tighten set screw with an allen wrench.
10	Press DISPLAY key to exit calibration mode.
11	Remove AC power to the actuator. Reinstall relay cards if present.
12	Install a new gasket and replace extended cover. Secure to actuator with screws.
13	Continue with calibration procedure in Table 31.

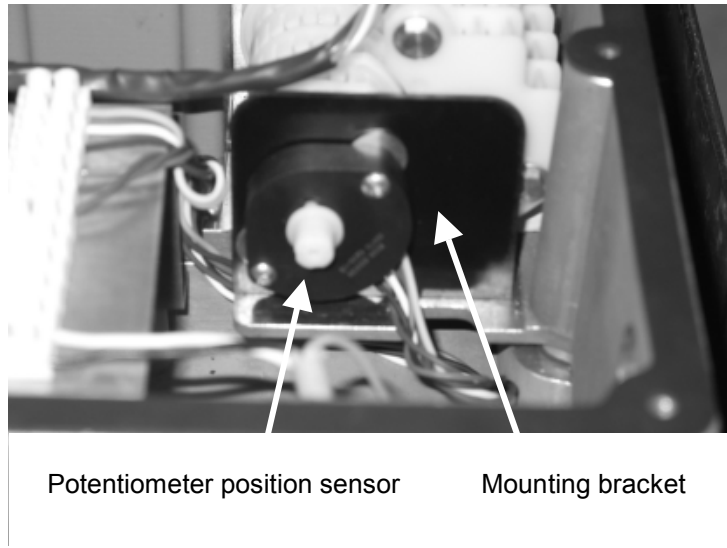

**Figure 29 Location of potentiometer position sensor**

**Table 31 Load Position Sensor Factory Calibration**

Step	Action
1	Reapply AC power to the actuator.
2	Press SET UP key to access the MAINT set up group. Press the FUNCTION key until the display reads LD CAL.  Press the ▲ or ▼ keys until the display reads POS.
3	Perform the Calibrate Motor procedure exactly as in Table 26 Motor calibration must be performed for the factory configured full span range (0-100%).  <b>ATTENTION</b>  When calibrating the motor to a short stroke range, you must reset the end-of-travel limit switches. See <i>Setting End-of-Travel Limit Switches</i> .
4	When motor calibration is complete, the calibration is now stored as the factory calibration of the actuator motor.

## Setting End-of-Travel Limit Switches



### ATTENTION

Referring to Figure 31. The first two cams (starting from the front) are for the 0% and 100% limit switches (Switch #1 and Switch #2) and should not need any adjustments as they are factory set to stop the drive at 0% and 100%. See Figure 30 for limit switch settings.

---

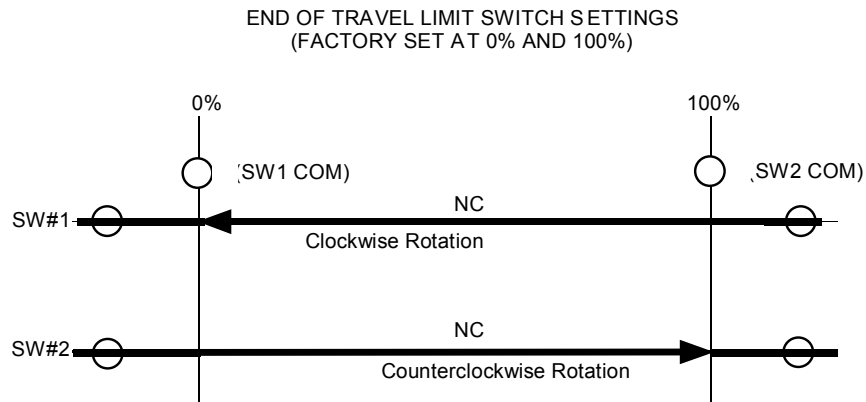

**Figure 30 End of Travel Limit Switch Settings**



### REFERENCE

An unactuated switch will have its normally closed (NC) contacts closed and its normally open (NO) contacts open.

An actuated switch will have its NC contacts become open and its NO contacts become closed. Both NC and NO contacts are available at the terminal block. See Figure 8 (page 18) and Figure 9 (page 19).

An unactuated switch has its roller arm in the up position when adjacent to the reduced diameter portion of the cam.

---

If it becomes necessary to do adjust the limit switch cams in the field, use the procedure given in Table 32.

---



**WARNING** While the unit is powered, a potentially lethal shock hazard exists inside the case.

---

**Table 32 End-of-Travel Limit Switch Setting Procedure**

Step	Action
1	Remove AC power to the actuator.
2	Remove the six screws and the cover from the actuator case. See Figure 2. Lay cover assembly on a flat surface.
3	<p>Using a flat blade screwdriver in the slots at the edge of the cams, or your finger, rotate the cams until the switches are set. (See Figure 31).</p> <ul style="list-style-type: none"> <li>• Rotate the actuator shaft, using the manual handwheel or the auto-manual switch, to the 0% position (this is the 0% for CCW operation using the bottom scale or 100% for CW operation using the top scale). If the actuator is installed on a damper or valve, also make sure that this position is synchronized with the travel of the final control element.</li> <li>• Rotate the #1 limit switch operating cam to activate at this position. The switch roller arm should go from being in an up, not depressed state, to a depressed state as the cam is rotated in the direction of the shaft rotation going toward the limit position. This will cause the switch to go from NC to NO and turn off the power to the motor when the switch activates. Switch activation may be detected by the clicking sound or with a continuity tester connected to the terminals.</li> <li>• Rotate the actuator shaft, using the manual handwheel or the auto-manual switch, to the 100% position (this is 100% for CCW operation using the bottom scale or 0% for CW operation using the top scale). If the actuator is installed on a damper or valve, also make sure that this position is synchronized with the travel of the final control element.</li> <li>• Rotate the #2 limit switch operating cam to activate at this position. The switch roller arm should go from being in an up, not depressed state, to a depressed state as the cam is rotated in the direction of the shaft rotation going toward the limit position. This will cause the switch to go from NC to NO and turn off the power to the motor when the switch activates.</li> <li>• If optional auxiliary switches were ordered, these switches may also be set at this time. (See Setting Auxiliary Switches (page 81).</li> </ul>
4	Double check limit switch actuation by first manually driving the actuator to each end of travel and hearing the switch click or by detecting it with a continuity tester. Secondly, drive the actuator to both ends of travel (using the auto/manual switch or by providing minimum and full input signal) and make sure the switches activate and turn off the motor.



**ATTENTION**

Make sure you do not set the switches too close to the hard stop.

---

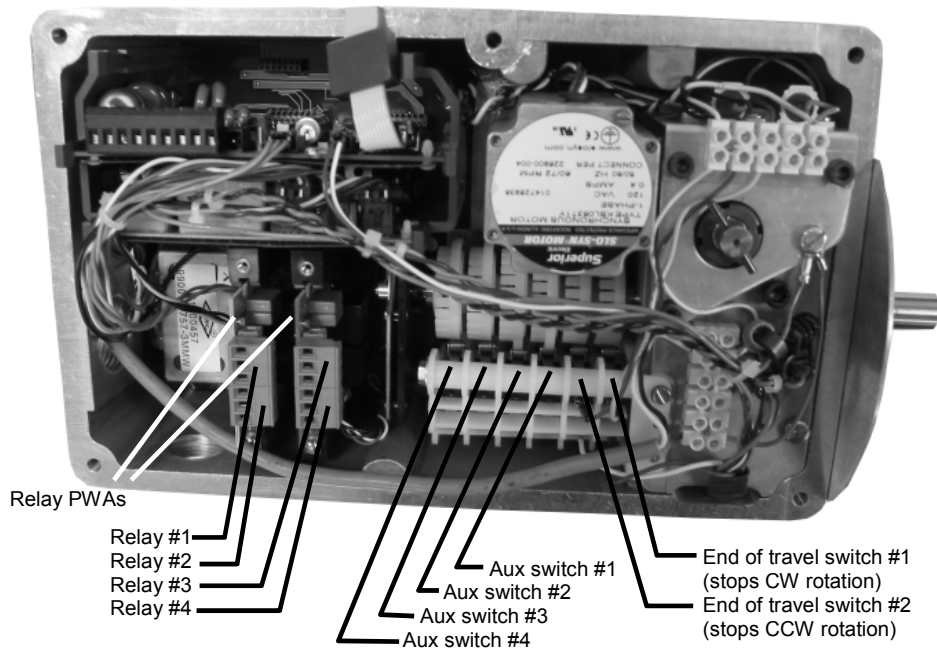

**Figure 31 Location of End-of-Travel Limit and Auxiliary Switches**



## Setting Auxiliary Switches



### ATTENTION

Referring to Figure 31. The first two cams (starting from the front) are for the 0% and 100% end of travel limit switches (**Switches #1 and #2**) and should not need any adjustments as they are factory set to stop the actuator precisely at 0% and 100%. See Setting End-of-Travel Limit Switches (page 78).

Additional switch settings should be set so that switch #3 operates in synchronism with switch #1 (i.e., both activating when the actuator is going in the same direction) and switch #4 to operates in synchronism with switch #2, etc. See Figure 32 for auxiliary switch settings.

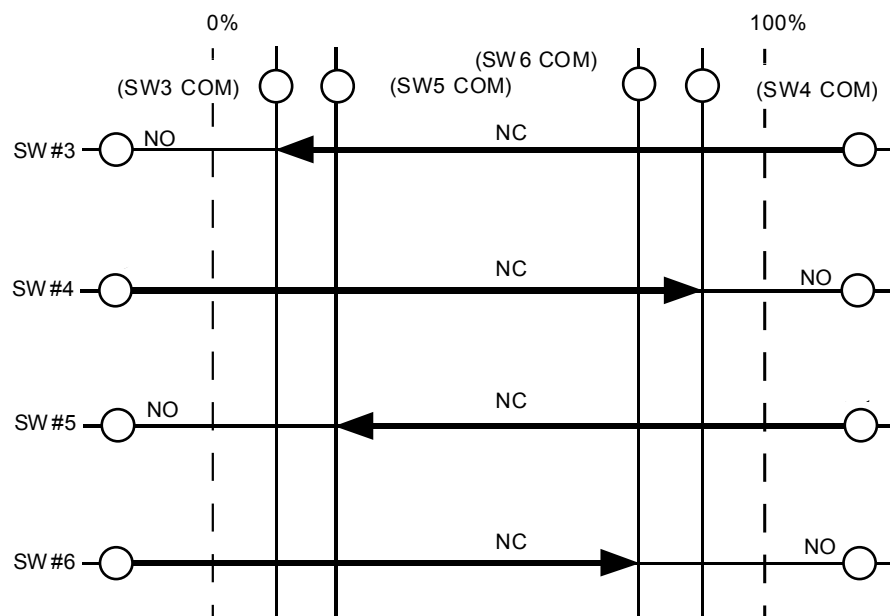

**Figure 32 Auxiliary Switch Settings**

If it becomes necessary to do adjust the auxillary switch cams in the field, use the procedure given in Table 33.



### WARNING

While the unit is powered, a potentially lethal shock hazard exists inside the case.

**Table 33 Auxiliary Switch Setting Procedure**

Step	Action
1	Remove AC power to the actuator.
2	Remove the six screws and the cover from the actuator case. See Figure 2. Lay cover assembly on a flat surface.
3	<p>Using a flat blade screwdriver on the slots on edge of cams, or your fingers, rotate the cams until the switches are set. (See Figure 31)</p> <ul style="list-style-type: none"><li>The auxiliary switches should be set so switches #3 and #5 operate in synchronism with switch #1 (i.e., both activating when the drive is going in the same direction) and set switches #4 and #6 to operate in synchronism with switch #2. See Figure 32 for auxiliary switch settings.</li></ul>
4	<p>For Switches #3 and #5:</p> <ul style="list-style-type: none"><li>Rotate the actuator shaft, using the manual handwheel or the auto-manual switch, to the desired low scale position.</li><li>Rotate the #3 switch operating cam to activate at this position. The switch roller arm should go from being in an up, not depressed state, to a depressed state as the cam is rotated in the direction of the shaft rotation going toward the limit position. This will cause the switch to go from NC to NO and turn off the power to the motor when the switch activates. Switch activation may be detected by the clicking sound or with a continuity tester connected to the terminals.</li><li>Repeat for Switch #5 if applicable.</li></ul>
5	<p>For Switches #4 and #6:</p> <ul style="list-style-type: none"><li>Rotate the actuator shaft, using the manual handwheel or the auto-manual switch, to the desired up scale position.</li><li>Rotate the #4 switch operating cam to activate at this position. The switch roller arm should go from being in an up, not depressed state, to a depressed state as the cam is rotated in the direction of the shaft rotation going toward the limit position. This will cause the switch to go from NC to NO and turn off the power to the motor when the switch activates.</li><li>Repeat for Switch #6 if applicable.</li></ul>
6	Double check limit switch actuation by first manually driving the actuator to each end of travel and hearing the switch click or by detecting it with a continuity tester. Secondly, drive the actuator to both ends of travel (using the auto/manual switch or by providing minimum and full input signal) and make sure the switches activate and turn off the motor.

# Start-Up/Operation

## Introduction

After the actuator is completely installed, wired, and the preliminary adjustments made, it is advisable to check the operation of the actuator and controlled device before placing it in service. In other words, operate the controlled device and check its direction of travel in response to an increase of the input signal and make sure it is correct for the process. Actuators having the optional auto-manual switch must have the knob set in the AUTO position.

This section provides a checklist that can be used to do a walk-through with the actuator before it is actually used for control. Other features which may be helpful in understanding actuator operation are also provided.

## Power-up Diagnostics

When power is applied to the actuator, the actuator electronics performs a diagnostic routine on various device components. These tests include a:

- RAM diagnostic (RAMTST),
- Check of the electrically erasable PROM (SEETST),
- Verification that valid parameter values are in the actuator configuration (CFGTST),
- Verification of valid calibration values (CALTST)
- Test of the local display and LED indicators (all display segments and LED indicators light simultaneously).

The local display shows the status of the diagnostics as they are completed during power up. TEST DONE is shown on the display when diagnostics are complete and actuator should be in AUTO mode. See Table 20 for more information on the power up diagnostics.

## Operations Checklist

To make sure that the actuator is properly installed and set up for your particular application, you should check and verify the following:

- Verify that the configuration is correct for your application by stepping through all set up groups and checking the setting of all set up parameters.
- Verify operation of end-of-travel limit switches.
- Verify operation of auxiliary switches or relay function (if installed).
- Check operation of AUTO - MANUAL DRIVE switch (if present), by setting the knob to the CW and CCW - MANUAL positions. The output shaft should rotate in the direction indicated by the knob. The LED indicator on the local display should also indicate the actuator is in manual mode.

## Operating Displays

Pressing the DISPLAY key cycles the display through a number of operating parameters. Table 34 shows a number of sample displays that can be shown during operation.

**Table 34 Typical Operating Displays**

Display		Description
0.0 INP	Input—	Upper Display = Shows input value Lower Display = prompt
00 OP 0.5	Output—	Upper Display = Shows input value Lower Display = Shows output value
100.0 DE 99.9	Deviation—	Upper Display = Shows input value Lower Display = Shows value of deviation of sensor from input.
0.6 POS	Position—	Upper Display = Shows value of position sensor. Lower Display = prompt
NOTE: Position display will show negative values, if appropriate.		

NOTE: When the AUTO/MANUAL key is pressed, placing the actuator in manual mode, the local display mode is forced to the Position display (POS). The Manual L.E.D. indicator should be lit. When the AUTO/MANUAL key is pressed again, placing the actuator in auto mode, the local display mode is forced to the Output display (OP). The Auto L.E.D. indicator should be lit. Set up parameters can still be accessed.

## Motor Stall

The actuator is equipped with a low current motor that prevents against burnout if the motor becomes stalled. A stall condition occurs when the motor position does not follow the input, or if the motor does not reach setpoint within a given period of time.

When the stall condition occurs, a stall alarm is indicated. The actuator sets the STALLED LED indicator ON and also any other alarms or relay contacts that are programmed to close whenever a stall condition is detected.

The motor drive for the indicated direction is shut off approximately 3 minutes after the stall alarm is indicated. Also, the appropriate CW/CCW LED direction indicator is turned OFF.

The maintenance statistic for accumulated stall time gets updated during the stalled condition.

To reactivate the drive in the stalled direction, change the position of the drive to the opposite direction and set at a point below where the stall originally occurred, then start the drive in the stalled direction.

Note: A stall condition is not detected if a limit end of travel limit switch is activated while the motor is moving toward the setpoint, or if the motor position is within 0.5% of calibrated motor 0% and 100% end points.”

## Position Sensor Operation

On HercuLine® 2000 and HercuLine® 2001 the potentiometer position sensor is a sealed film pot that is directly coupled to the output shaft. On HercuLine® 2002 the non-contact sensor (NCS) is inductively coupled to the output shaft of the actuator so that the sensor detects shaft position. The sensor is adjusted at the factory and under normal conditions and requires no adjustment. A simple check can verify that the sensor working properly and that it is in adjustment. Verification of the output is performed by setting the drive motor to its zero, midpoint and 100% positions and observing the output voltage of the sensor. The actuator has a feature that the sensor output voltage can be read from the local display.

Step	Action
1	Drive the motor to 50% position.
2	<p>Press SET UP key on the keyboard until the display reads CAL POSOUT.</p> <p>Press FUNCTION key until the display reads DIS CALPOS.</p> <p>Press the ▲ or ▼ keys until the display reads BEGN CALPOS.</p> <p>Press the FUNCTION key.</p> <p style="text-align: center;"><i>Upper Display</i> = <b>n.nnn</b> (Output voltage of the sensor) <i>Lower Display</i> = <b>POSOUT</b></p>
3	The display should read 2.500 +/- 0.012 Volts for both 90° and 150° operation.
4	<p>Press DISPLAY key and then drive the motor to zero position. Repeat Step 2.</p> <p>The display should read 1.600 +/- 0.060 Volts for 90° operation; 1.000 +/- 0.060 volts for 150° operation.</p>
5	<p>Press DISPLAY key and then drive the motor to 100% position. Repeat Step 2.</p> <p>The display should read 3.400 +/- 0.060 Volts for 90° operation; 4.000 +/- 0.060 volts for 150° operation.</p>
6	If the sensor needs adjustment, refer to the "Calibrate Non-Contact Sensor" procedure in Table 29 (page 74).

## Remote Setpoint Operation

The HercuLine® 2001/2002 actuator can be set up to receive a digital input from a remote source. The actuator uses RS485 communications that supports digital Modbus RTU protocol. Press the SET UP key to select the Input set up group. Change the Input Type to Remote Setpoint (R\_SP). Make the necessary connections to terminals 6, 7, 8 on the actuator terminal block. See Figure 33. Communication parameters should be set to the same values as the host device. The actuator communication parameters are accessed in the Communications Set Up group.

There are some restrictions to actuator operation when remote setpoint input is active. In order to provide a bumpless transfer when switching from one input signal type to remote setpoint, the actuator will use the last known analog input value as its setpoint when switching to remote setpoint input operation. No input filtering is active on the input signal to the actuator.

## Actuator Terminal Block

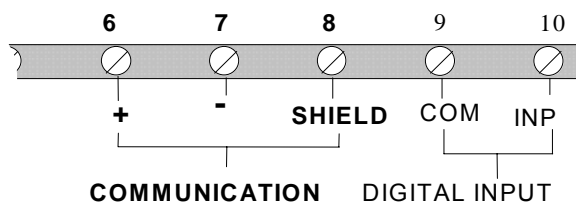

**Figure 33 Terminal Block Connections for Modbus Communications**

# Maintenance

## Introduction

There is some basic maintenance that is recommended for the HercuLine® 2000 Series Actuators. The electronic PWAs within the actuator require no maintenance or servicing under normal conditions.

If there is a problem, refer to information in this section or to Troubleshooting (page 105) .

## Basic Maintenance

### Position Sensor

Under normal conditions the position sensor does not require maintenance.

### Main Gear Lubrication

Under normal operating conditions, the main worm gear should not require maintenance.

### Spur Gear Lubrication

Honeywell recommends that during major shutdown periods the spur gears should be inspected and lubricated. Follow the steps in Table 35 to access the spur gear compartment and lubricate the gears if necessary.

---

**⚠ WARNING** Disconnect power before opening the actuator case to inspect the actuator gears. A potentially dangerous pinch hazard exists inside the case if the unit is open while powered.

---

**Table 35 Spur Gear Lubrication Procedure**

Step	Action
1	Remove AC power from actuator.
2	Remove the six screws and the bottom cover of the actuator case. See Figure 34.
3	Inspect the final spur gear, the idler gear and motor pinion for excessive wear and adequate lubrication. See Figure 34.
4	If needed, use Texaco Starplex 2 EP grease, or equivalent and apply lubricant to assure that the gears are adequately protected.
5	Install a new gasket and replace side cover. Secure to actuator with screws.
6	Restore actuator to service.

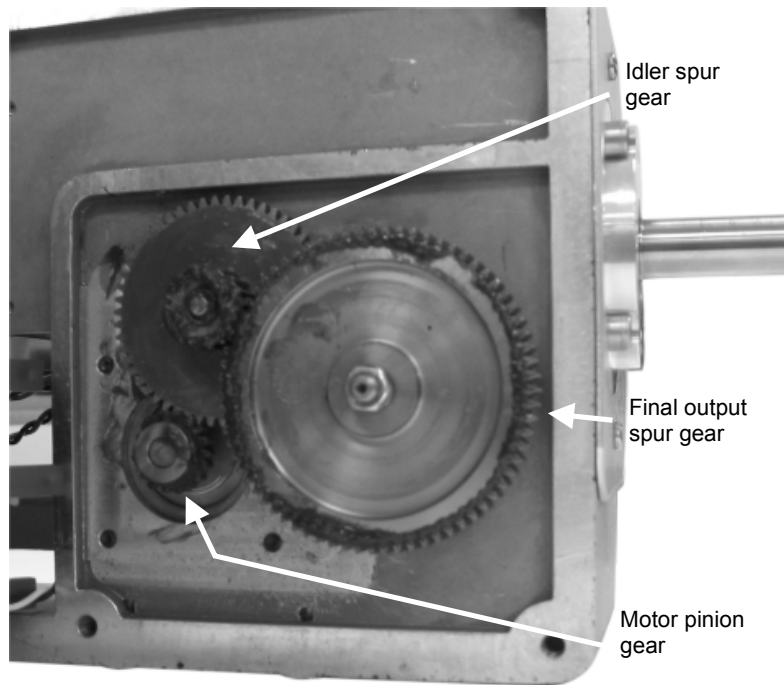
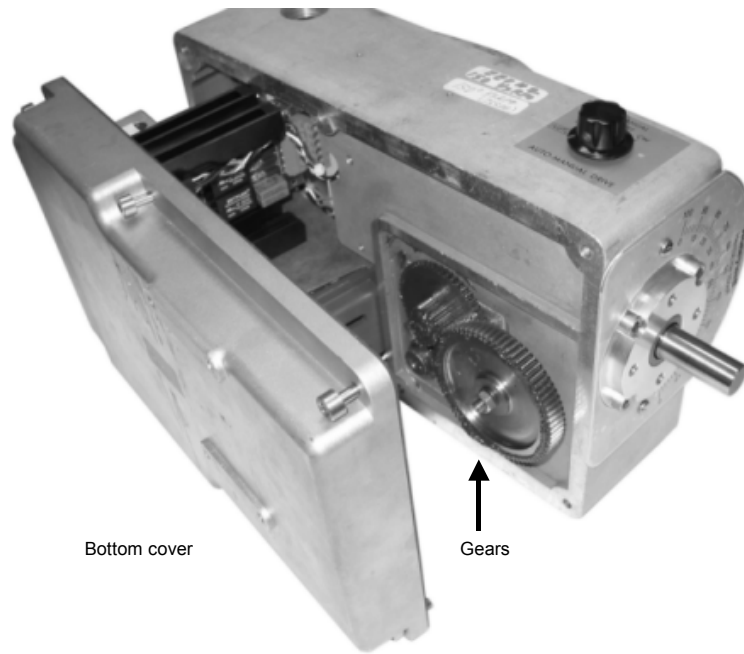

**Figure 34 Spur Gear Location**



## Replacement Procedures

### Fuse Replacement

The motor drive circuit contains two fuses. They are located on the power distribution PWA. If it becomes necessary to replace these fuses, follow the procedure in Table 36 and refer to Figure 36 for fuse location.



#### WARNING

Disconnect power before opening the actuator case to replace the fuse(s). A potentially lethal shock hazard exists inside the case if the unit is opened while powered.

**Table 36 Motor Drive Fuse Replacement Procedure**

Step	Action
1	Remove AC power from actuator.
2	Remove the 6 screws and the extended cover of the actuator case. See Figure 35.
3	Lay assembly down on a flat surface.
4	Remove connectors from CPU and power distribution PWA.
5	Remove power distribution PWA.
6	Locate the two fuses on the power distribution PWA. See Figure 36. Carefully remove and replace fuse(s) with Wickmann T1 type 6A 250V, or equivalent (not available from Honeywell).
7	Reinstall power distribution PWA.
8	Reconnect connectors to CPU and power distribution PWA.
9	Install a new gasket and replace extended cover. Secure to actuator with screws.

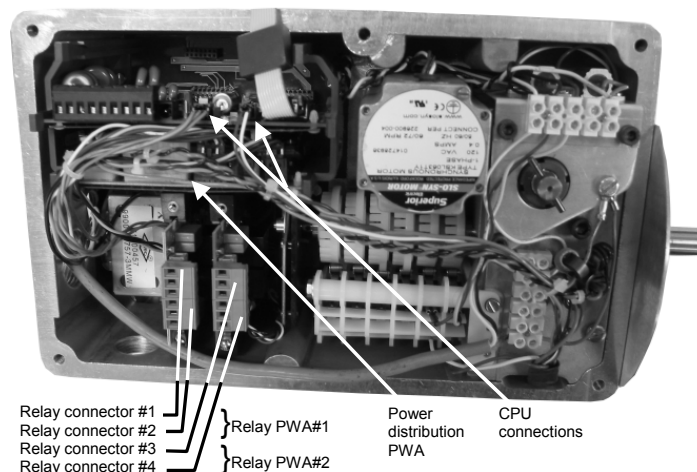

**Figure 35 Power Distribution PWA and Relay PWA Locations**

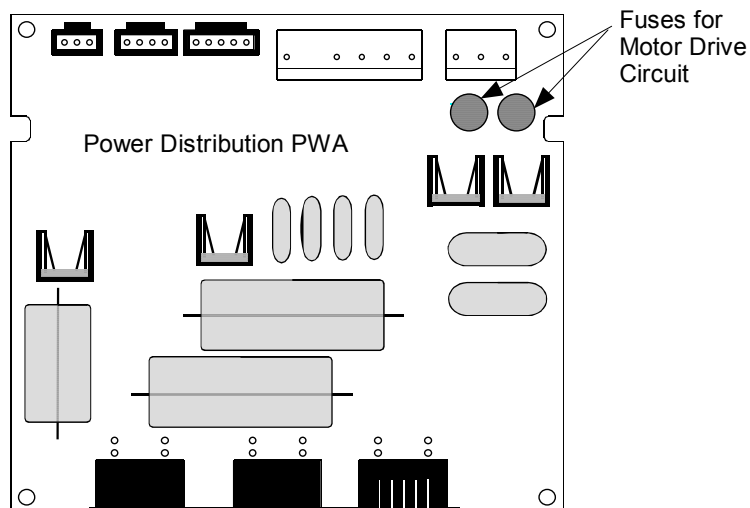

**Figure 36 Motor Drive Circuit Fuses**

### Relay PWA Replacement

If a relay PWA needs to be replaced, follow the procedure in Table 37 to access and replace the PWA.



**WARNING**

Disconnect power before opening the actuator case. A potentially lethal shock hazard exists inside the case if the unit is opened while powered.

**Table 37 Relay PWA Replacement Procedure**

Step	Action
1	Remove AC power from actuator.
2	Remove the six screws and the cover of the actuator case. See Figure 35.
3	Lay assembly down on a flat surface.
4	Disconnect the wire connector from the relay PWA.
5	Carefully remove the relay PWA. Pry the locking tabs of the card guides away to unlock the PWA and slide it out from the card guides.
6	Install the replacement relay PWA by sliding it into the card guides until it mates with the backplane board. Locking tabs on the card guides will engage to secure the PWA in place.
7	Plug in wire connector to relay PWA.
8	Install a new gasket if needed and replace cover. Secure to actuator with screws.

## Replacement/Upgrade/Accessory Kits

### Replacement Kits

This section provides you with a complete list of all the spare parts that may be needed for the HercuLine® 2000 Series Actuators and optional equipment.

To determine which kit you need, cross-reference Figure 37 through Figure 41 with Table 38 on page 96.

Each kit contains replacement parts accessories and instructions for component replacement.

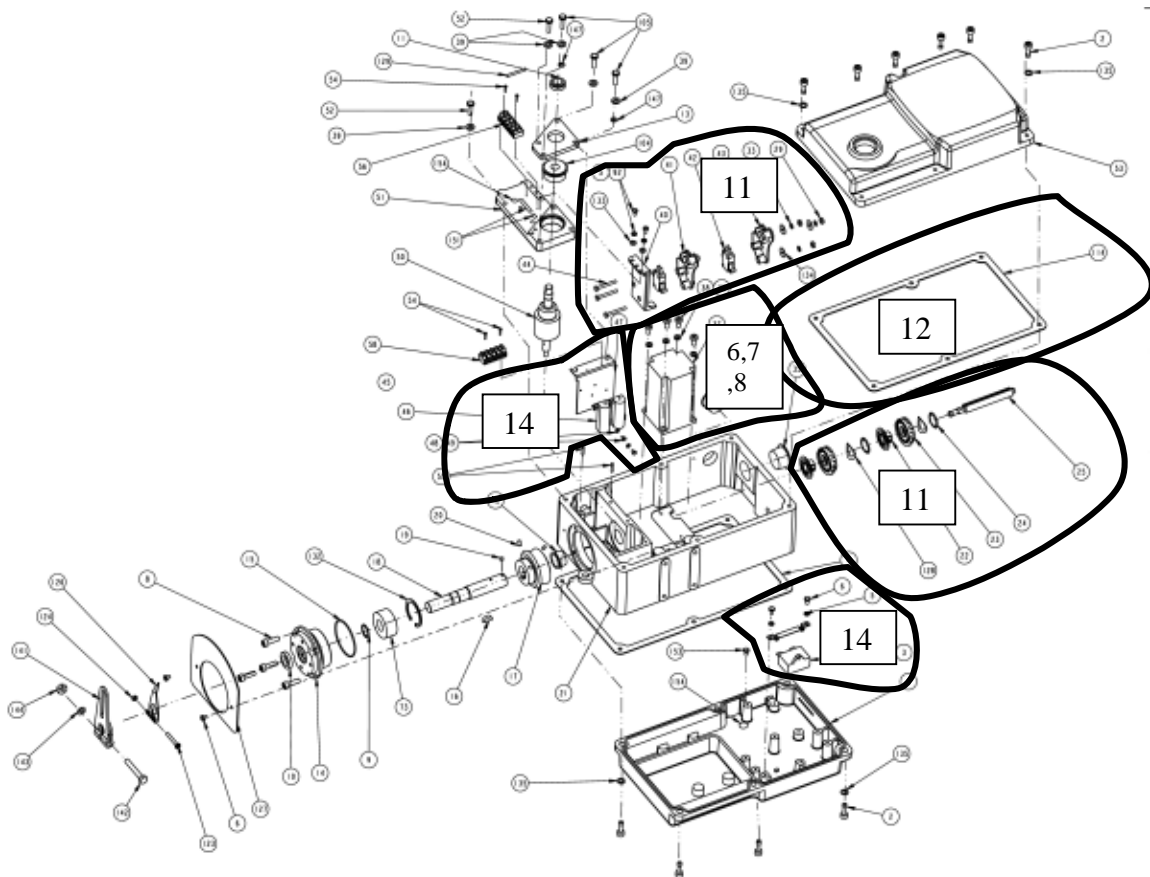

Figure 37 Replacement Kits 6, 7, 8, 11, 12, 14

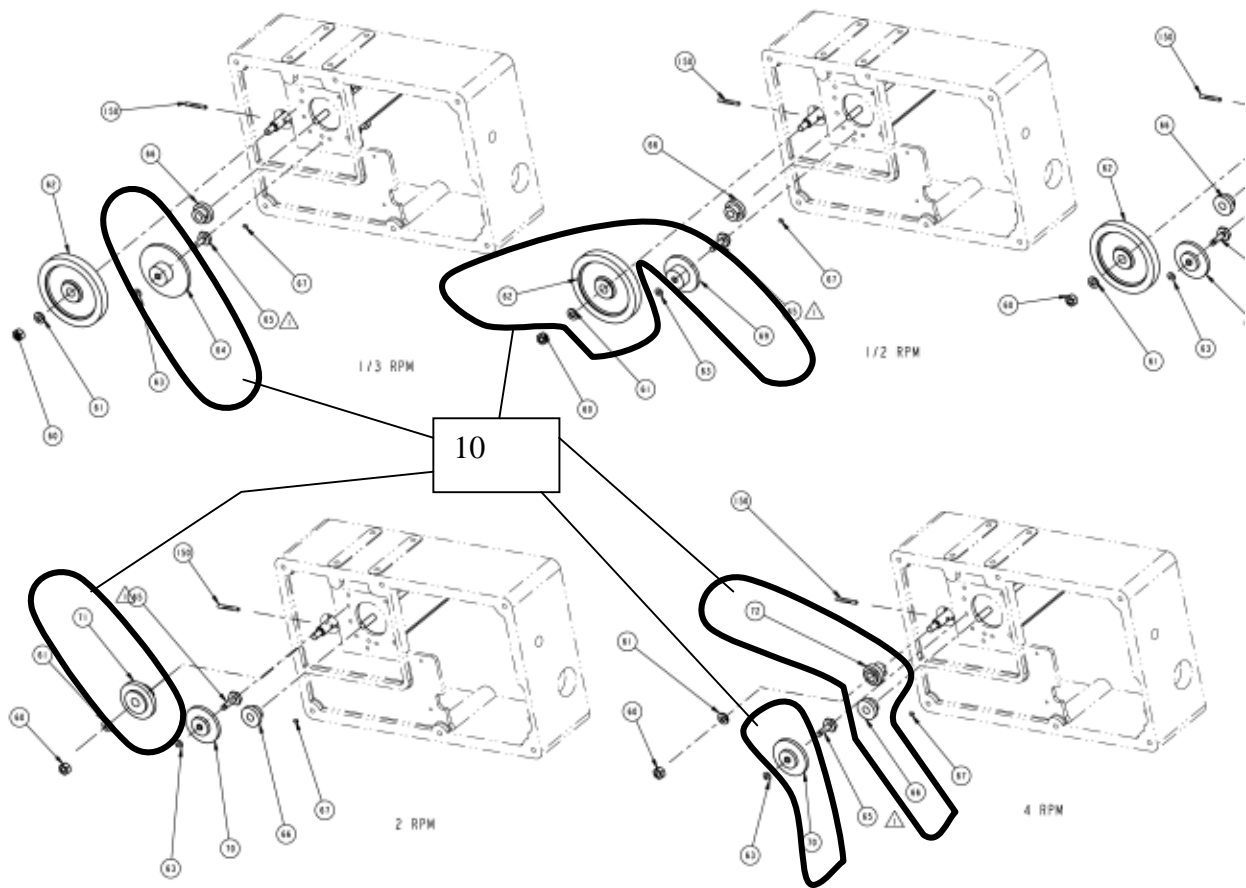

Figure 38 Replacement Kit 10

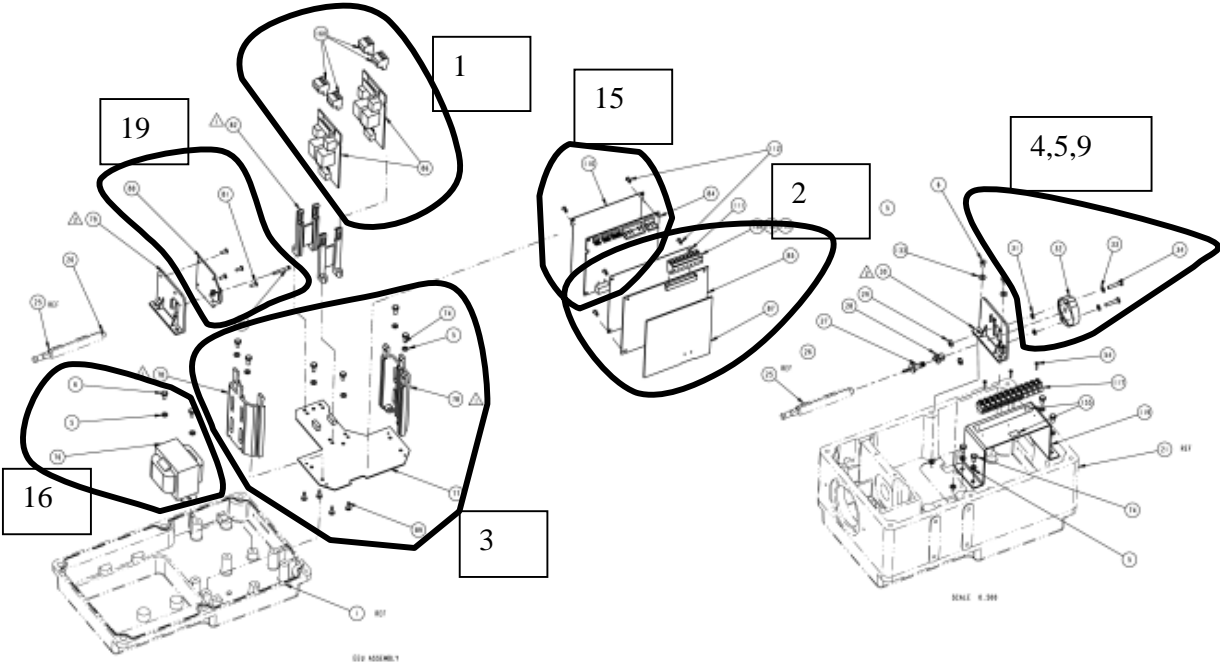

Figure 39 Replacement Kits 1, 2, 3, 4, 5, 9, 15, 16, 19

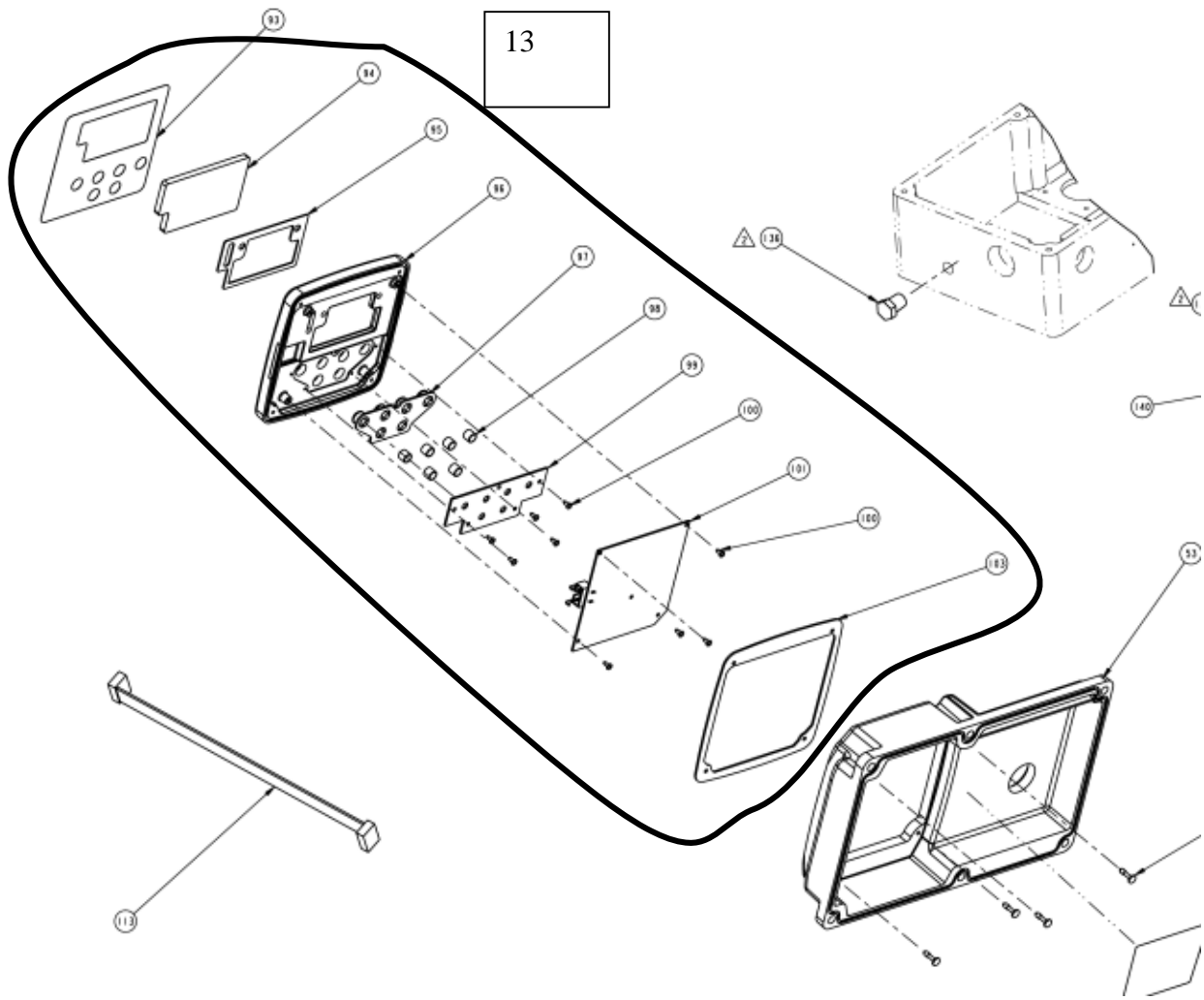

Figure 40 Replacement Kit 13

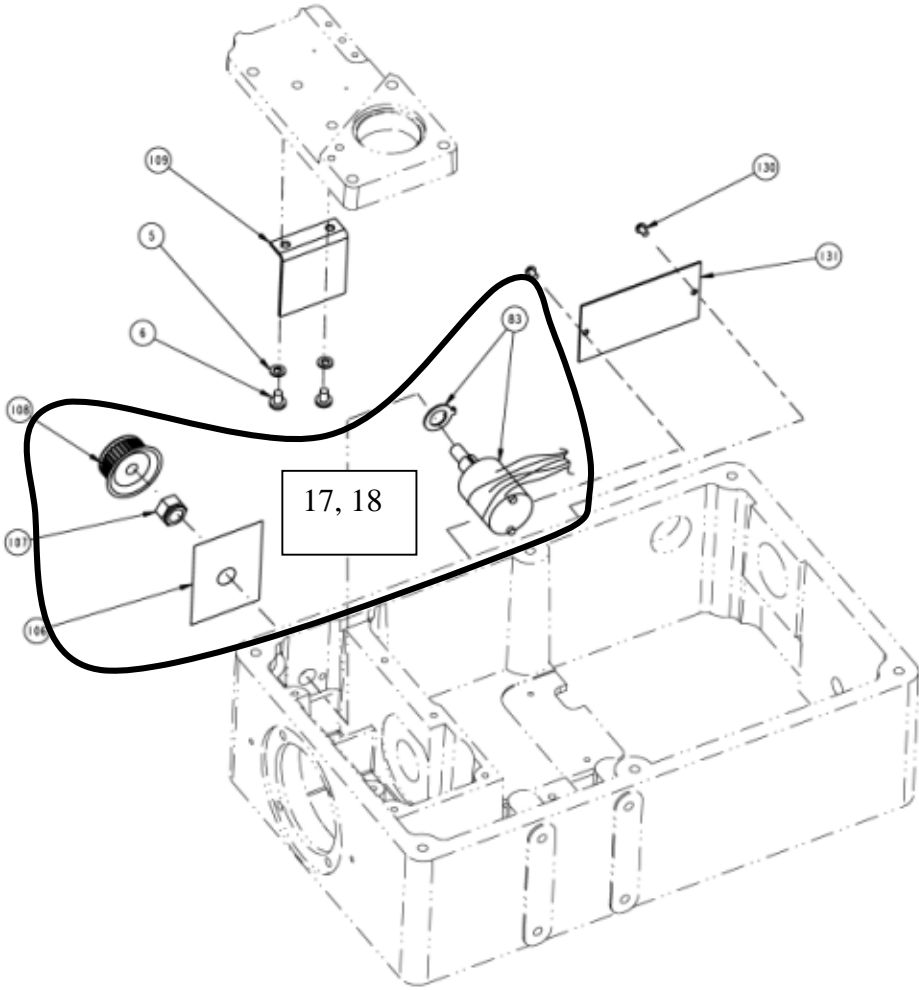

Figure 41 Replacement Kits 17, 18

See Figure 37 through Figure 41 for drawings of replacement kit contents.

**Table 38 Replacement kits**

Qty/Unit	Part Number	Description	Figure ID #
	<b>51450802-503</b>	<b>Relay Kit</b>	<b>1</b>
2		Relay Pwa	
4		Plug 03 Position	
1		Top Cover Gasket	
Qty/Unit	Part Number	Description	Figure ID #
	<b>51451397-501</b>	<b>CPU Kit</b>	<b>2</b>
1		HercuLine® CPU Bd Assembly	
1		Plug, 10 Pos	
1		Label Phonix Connector 1 To 10	
1		Insulator	
4		Pin, Snap Lock, .125 X .187 Lg	
1		Top Cover Gasket	
Qty/Unit	Part Number	Description	Figure ID #
1	<b>51452302-501</b>	<b>PROM Kit</b>	<b>2</b>
Qty/Unit	Part Number	Description	Figure ID #
	<b>51451424-501</b>	<b>Backplane Kit</b>	<b>3</b>
1		HercuLine® Backplane Assy	
1		Card Guide Assy	
1		Card Guide	
4		Split Washer	
4		Machine Screw-Pan Head-Slotted	
4		Screw, Trilob Philph #4-20x.38	
1		Top Cover Gasket	
Qty/Unit	Part Number	Description	Figure ID #
	<b>51451656-505</b>	<b>1000 Ohm Potentiometer Kit 90 Degrees (HercuLine® 2000)</b>	<b>4</b>
1		Pot 1 K Double 90 Degree	
2		#6-32 Hex Nut N	
2		#6 Washer	
2		#6 Lock Washer	
2		Machine Screw-Pan Hd-Cross Rec	
1		Top Cover Gasket	
		Kit Instruction# 62-86-33-38	



Qty/Unit	Part Number	Description	Figure ID #
	<b>51451656-506</b>	<b>1000 Ohm Potentiometer Kit 150 Degrees (HercuLine® 2000)</b>	<b>5</b>
1		Pot 1 K Double 150 Degree	
2		#6-32 Hex Nut N	
2		#6 Washer	
2		#6 Lock Washer	
2		Machine Screw-Pan Hd-Cross Rec	
1		Top Cover Gasket	
		Kit Instruction# 62-86-33-38	
Qty/Unit	Part Number	Description	Figure ID #
	<b>50018180-501</b>	<b>Upgrade to Non Contact Position Sensor (HercuLine® 2001)</b>	<b>6</b>
1		PCB Assembly	
4		Screws SEMS #4-40 x .310 lg	
1		Gasket	
1		Cable Assembly	
1		RVI T-Z Setup Gage	
1		Bracket Molding	
1		Stainless Steel Pin	
1		Set Screw 3/32 x 4-40	
		Kit Instruction# 62-86-33-46	
Qty/Unit	Part Number	Description	Figure ID #
	<b>51452342-501</b>	<b>10K Ohm Potentiometer Kit (HercuLine® 2001)</b>	<b>9</b>
1		Position Sensor SA2001	
2		#6-32 Hex Nut N	
2		#6 Washer	
2		#6 Lock Washer	
2		Machine Screw-Pan Hd-Cross Rec	
1		Top Cover Gasket	
		Kit Instruction# 62-86-33-40	
Qty/Unit	Part Number	Description	Figure ID #
	<b>515000657-502</b>	<b>Rvit-Z Ncs Replacement Kit</b>	<b>19</b>
1		Ncs, Rvit-Z Pwa 0-150	
4		Machnl 4-40 X .31 Pnslstl	
1		Top Cover Gasket	

Qty/Unit	Part Number	Description	Figure ID #
	<b>51452174-501</b>	<b>Crank Arm Kit</b>	<b>6</b>
1		Crank Arm	
1		Screw,Hex Hd,1 3/4 X 1/4-20	
1		Kllwss1/4sp	
1		Nut Nmsndc 1/4-20	
Qty/Unit	Part Number	Description	Figure ID #
	<b>50011455-501</b>	<b>120vac/60HZ Motor Kit</b>	<b>7</b>
1		Motor 120v,50/60 Hz,	
1		Capacitor, 3 µfd 400Vac	
1		Cable plus Resistor assembly, 600 Ohm	
1		Resistor Bracket	
4		Split Washer M5	
4		M3 X 5mm lg screw w/ext tooth lock washer	
4		Socket head cap screw-M5 x 12	
1		Top Cover Gasket	
		Kit Instruction# 62-86-33-36	
Qty/Unit	Part Number	Description	Figure ID #
	<b>50011455-502</b>	<b>120vac/50HZ Motor Kit</b>	<b>7</b>
1		Motor 120v,50/60 Hz,	
1		Capacitor, 4.0 µfd 400Vac	
1		Cable plus Resistor assembly, 400 Ohm	
1		Resistor Bracket	
4		Split Washer M5	
4		M3 X 5mm lg screw w/ext tooth lock washer	
4		Socket head cap screw-M5 x 12	
1		Top Cover Gasket	
		Kit Instruction# 62-86-33-36	
Qty/Unit	Part Number	Description	Figure ID #
	<b>50011455-503</b>	<b>240VAC/50/60HZ Motor Kit</b>	<b>7</b>
1		Motor 240v,50/60 Hz,	
1		Capacitor, .75 Mfd 400Vac	
1		Cable plus Resistor assembly, 1100 Ohm	
1		Resistor Bracket	
4		Split Washer M5	
4		M3 X 5mm lg screw w/ext tooth lock washer	
2		Butt Splice (SA2000)	
4		Socket head cap screw-M5 x 12	
1		Top Cover Gasket	
		Kit Instruction# 62-86-33-36	

Qty/Unit	Part Number	Description	Figure ID #
	<b>51452443-501 51452443-507 51452443-508 51452443-509 51452443-510 51452443-511</b>	<b>Spur Gear Kit</b>	10
1		Spur Gear 24p, 18t	
1		Spur Gear 24p, 18t	
1		Spur Gear 24p, 36t	
1		Spur Gear 24p, 72t	
1		Gear Assembly	
1		Gear Assembly	
1		Spur Gear 24p, 36t	
1		Bottom Cover Gasket	
1		Intermediate Shaft all except 7.5 seconds	
1		Intermediate Shaft – 7.5 seconds	
		Kit Instructions# 62-86-33-35	
Qty/Unit	Part Number	Description	Figure ID #
	<b>51452443-502</b>	<b>Auxiliary Switch Kit Replacement and Upgrade</b>	11
1		Cam Assembly (4 Aux switches, 2 end of travel switches)	
1		Switch and Mounting Plate assembly (6	
		Kit Instruction# 62-86-33-45	
Qty/Unit	Part Number	Description	Figure ID #
	<b>51452443-503</b>	<b>Gasket Set Kit</b>	12
1		Bottom Cover Gasket	
1		Shaft Seal	
1		O-Ring 2.144 Id X 0.070 Buna N	
1		Top Cover Gasket	
1		O-Ring Buna N	
1		Display Gasket	

Qty/Unit	Part Number	Description	Figure ID #
	<b>51452443-504</b>	<b>Display and Keypad Kit</b>	13
1		Display Gasket	
1		Overlay, Display	
1		Lens, Display	
1		Gasket,Adhesive Die Cut	
1		Display Mtg Collar Machining	
1		Keypad, 6 Position	
1		Support Plate-Keypad	
1		Display Pwa	
9		Sems #4-40 X .310lg Pnphstl	
4		Screw,Metric Panhd,Cross Rec	
4		Split Washer	
6		Sleeve, Keypad	
1		Display/Keybd Cable	
1		Top Cover Gasket	
Qty/Unit	Part Number	Description	Figure ID #
	<b>51452443-505</b>	<b>R/C Kit (Motor date codes prior to 8/5/2005)</b>	14
1		Capacitor, 2.25 Mfd	
1		Resistor, 200 Ohm,25w	
1		Capacitor, .75 Mfd, 400vac	
1		Resistor, 500 Ohm,25w	
1		Top Cover Gasket	
1		Bottom Cover Gasket	
		Kit Instruction 62-86-33-44	

Qty/Unit	Part Number	Description	Figure ID #
	<b>51452443-506</b>	<b>R/C Kit (Motor date codes after to 8/5/2005)</b>	
1		Capacitor, 4.0 Mfd	1
1		Cable plus Resistor, 400Ohm	1
1		Capacitor, 3 Mfd, 400vac	1
1		Cable plus Resistor, 600 Ohm	1
1		Capacitor, 0.75 Mfd, 400vac	
1		Cable plus Resistor, 1100 Ohm	
1		Top Cover Gasket	1
1		Bottom Cover Gasket	1
		Kit Instruction 62-86-33-44	
Qty/Unit	Part Number	Description	Figure ID #
	<b>51500166-503</b>	<b>Power Distribution Pwa Kit</b>	15
1		Power Dist Pwa	
1		Insulator	
2		Pin, Snap Lock, .125 X .187 Lg	
1		Top Cover Gasket	
Qty/Unit	Part Number	Description	Figure ID #
	<b>51500457-502</b>	<b>Transformer Kit</b>	16
1		Transformer	
2		Split Washer	
2		Machine Screw-Pan Hd-Cross Rec	
1		Top Cover Gasket	
Qty/Unit	Part Number	Description	Figure ID #
	<b>51500581-503</b>	<b>Auto/Manual Switch (upgrade for SA2000)</b>	17
1		Auto/Manual Label	
1		Nut, Sealing 3/8-32 Thrd	
1		Knob	
1		A/M Switch/Wire Assy	
1		Label, Customer Wiring,	
1		Top Cover Gasket	

Qty/Unit	Part Number	Description	Figure ID #
	<b>51500581-504</b>	<b>Auto/Manual Switch (upgrade for SA2001 &amp; SA2002)</b>	18
1		Auto/Manual Label	
1		Nut, Sealing 3/8-32 Thrd	
1		Knob	
1		A/M Switch/Wire Assy	
1		Label, Customer Wiring,	
1		Top Cover Gasket	

## Upgrade Kits

Qty/Unit	Part Number	Description
	<b>51452444-502</b>	<b>Cover (with Display no Handwheel)</b>
1		Display gasket
1		Overlay, display
1		Lens, display
1		Gasket, adhesive die cut
1		Display mtg collar machining
1		Keypad, 6 position
1		Support plate-keypad
1		Display PWA
1		Top cover w/display no hndwhl
9		Sems #4-40 x .310lg pnphstl
4		Screw, metric panhd, cross rec
4		Split washer
6		Sleeve, keypad
1		Display/keybd cable HercuLine 2001/2002
1		Top cover gasket

Qty/Unit	Part Number	Description
	<b>51452444-503</b>	<b>Cover with Display and Handwheel</b>
1		Display gasket
1		Overlay, display
1		Lens, display
1		Gasket, adhesive die cut
1		Display mtg collar machining
1		Keypad, 6 position
1		Support plate-keypad
1		Display PWA
1		Top cover w/display & hndwheel
9		Sems #4-40 x .310lg pnpstl
4		Screw, metric panhd, cross rec
1		Hand wheel
1		O-ring buna n
4		Split washer
6		Sleeve, keypad
1		Display/keybd cable HercuLine® 2001/2002
1		Retaining ring
1		Shim
1		Top cover gasket
Qty/Unit	Part Number	Description
	<b>51452444-504</b>	Blank Cover with Handwheel
Qty/Unit	Part Number	Description
	<b>51451656-510</b>	<b>1000 ohms 90 degrees upgrade kit</b>
2		Machine screw-pan hd-cross rec
1		Knob
1		Bracket molding
1		Pot 1K double 90 degree
2		#6 lock washer
2		Machine screw-pan hd-cross rec
2		#6-32 hex nut N
1		Stainless steel pin
1		3/32x4-40 setscrew sshxsocupsb
2		Washer #6
2		Flat washer M4 (zinc)
2		Resistor 158 ohms 1% 1/2W
		Kit Instruction# 62-86-33-39

Qty/Unit	Part Number	Description
	<b>51451656-511</b>	<b>1000 ohms 150 degrees upgrade kit</b>
2		Machine screw-pan hd-cross rec
1		Knob
1		Bracket molding
1		Pot 1K double 150 degree
2		#6 lock washer
2		Machine screw-pan hd-cross rec
2		#6-32 hex nut N
1		Stainless steel pin
1		3/32x4-40 setscrew sshxsocupsb
2		Washer #6
2		Flat washer M4 (zinc)
2		Resistor 158 ohms 1% 1/2W
		Kit Instruction# 62-86-33-39

## Accessory Kits

Part Number	Description
<b>51197910-001</b>	<b>HAL Linkage Analysis software</b>
<b>51452354-509</b>	<b>HercuLink<sup>®</sup> software (PC/Palm)</b>
<b>51452354-510</b>	<b>Battery powered Palm/485 converter w/cables</b>
<b>51452174-501</b>	<b>Crank Arm - Standard</b>
<b>51452791-001</b>	<b>Crank Arm – 2003 Unit</b>
<b>51452352-501</b>	<b>Turk Cable for Communication Connection</b>



# Troubleshooting

## Introduction

Troubleshooting procedures can be followed when inaccurate or faulty actuator operation is detected. In this section, troubleshooting procedures consist of a few simple flow charts to test for proper function of various actuator components. Component replacement is at the PWA or assembly level.

Table 39 indicates some of the observable symptoms of failure that can be identified by noting the faulty actuator operation.

**Table 39 Observable Symptoms of Failure**

Symptom	Procedure
No Actuator current output.	Replace CPU Assembly
No Actuator slidewire output.	Replace CPU Assembly
Local display does not light.	See Figure 42
Actuator fails one or more power up diagnostics.	See Figure 43
Actuator motor does not drive in response to input signal.	Perform input calibration. See Figure 42
Actuator motor does not drive to proper position.	Perform motor calibration.
Actuator Motor is "Hunting" (Motor does not drive to a position and stop.)	Process control loop is not tuned correctly. Refer to the Instruction Manual for your controller on how to tune a loop.  Increase the Deadband in the Actuator and/or in the control loop.
Position sensor position is not correct.	See page 85.
Auto/Manual Switch does not operate correctly.	See Figure 45
Relay(s) does not operate.	See Figure 46

## Troubleshooting Procedures

### Overview

Follow the procedure or flow chart to test for and determine actuator component operation. When using the flow charts for troubleshooting, you may be instructed to go to another flow chart in order to identify the faulty component. Instruction for replacing actuator components can be found either in Maintenance (page 87) or in the kit with the replacement components.

### Equipment needed

You will need the following equipment in order to troubleshoot the symptoms listed in the tables that follow:

DC Milliammeter – mA DC

Calibration source – Volt, mA, etc.

Digital Voltmeter

### Safety precautions

Exercise appropriate safety precautions when troubleshooting the actuator operation.



While the unit is powered, a potentially lethal shock hazard exists inside the case. Do not open the case while the unit is powered. Do not access the terminals while the unit is powered.

---

**Test for Actuator Operation**

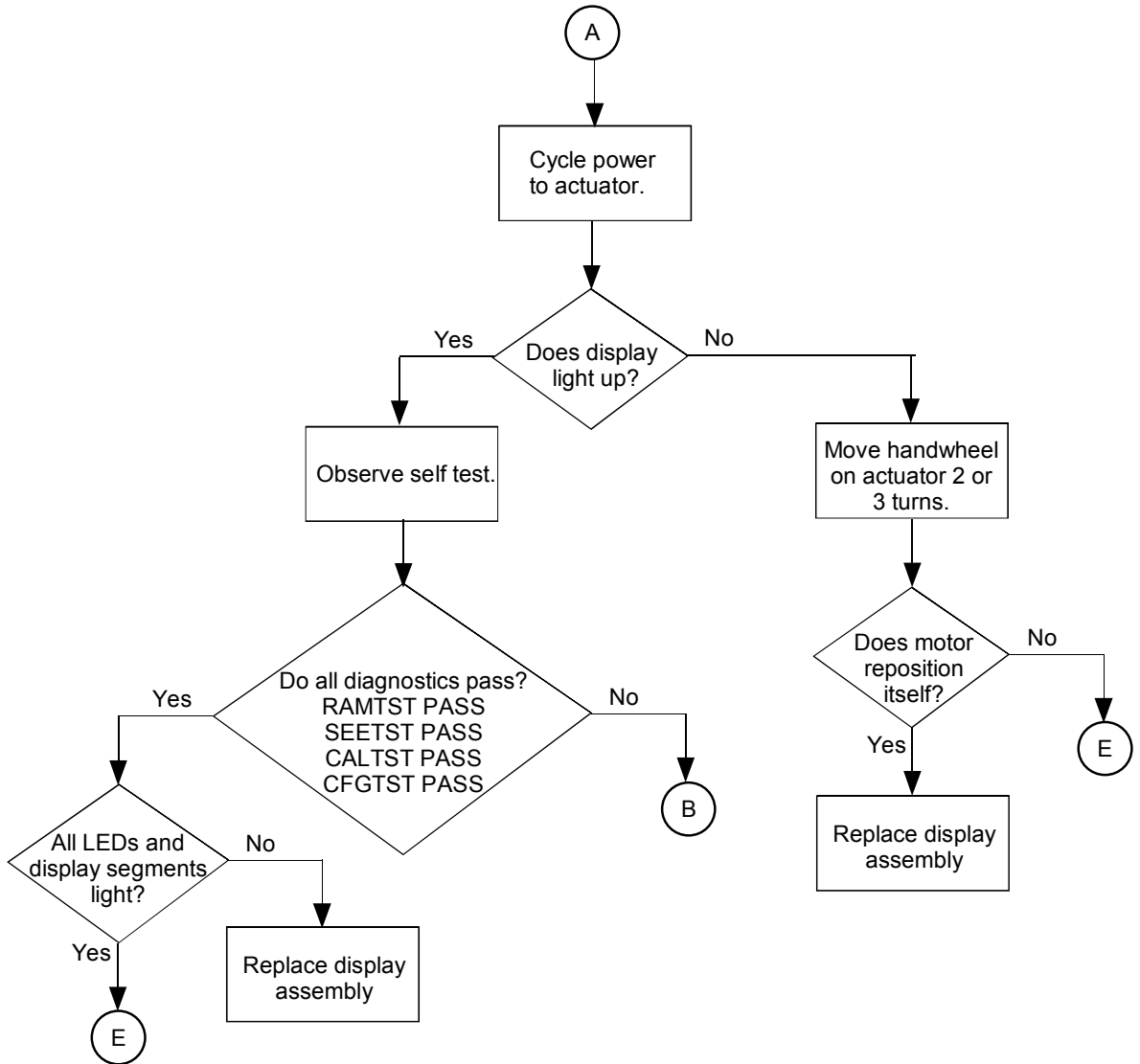

**Figure 42 Test for Actuator Operation**

**Power Up Self Test Diagnostics**

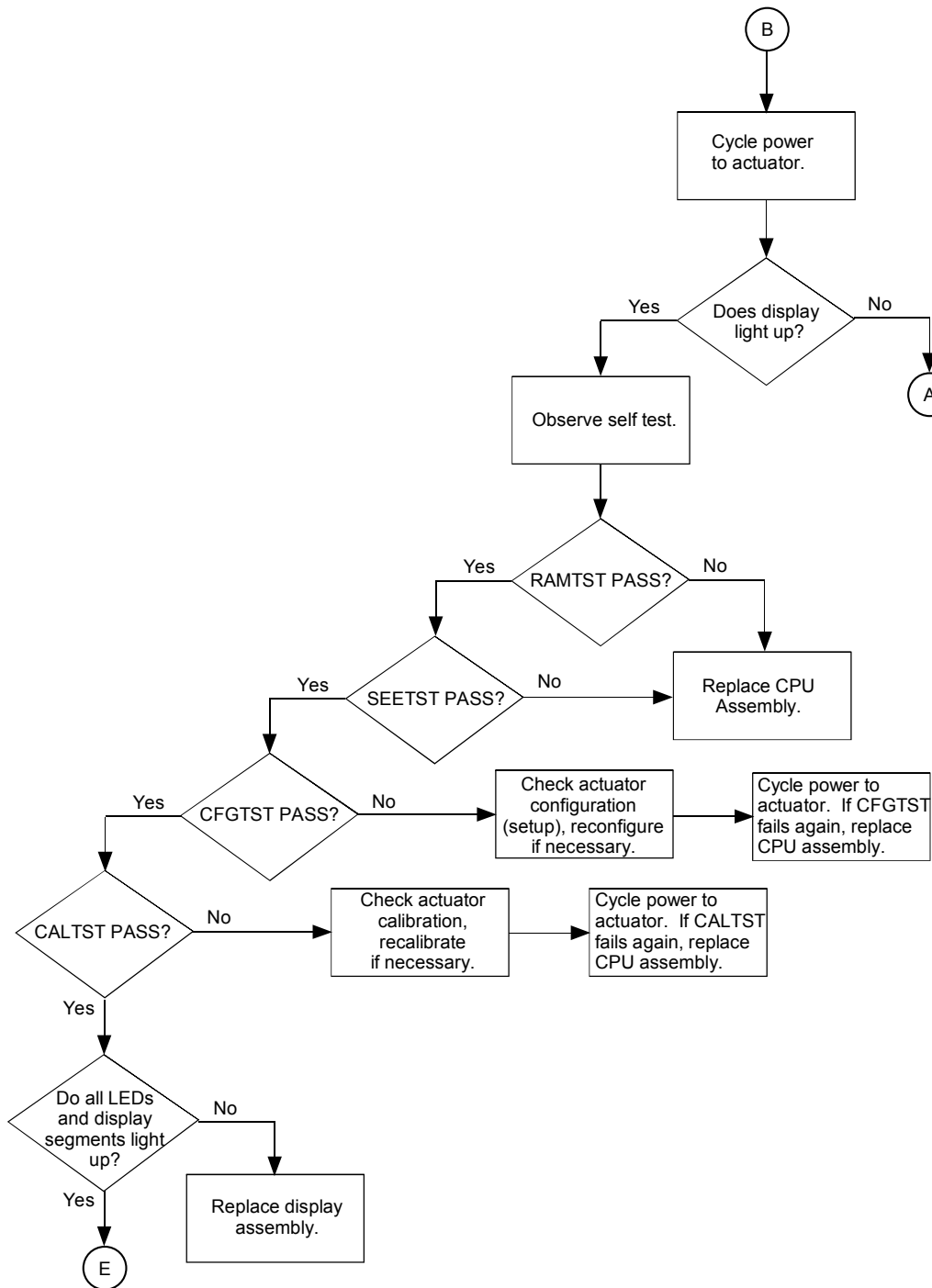
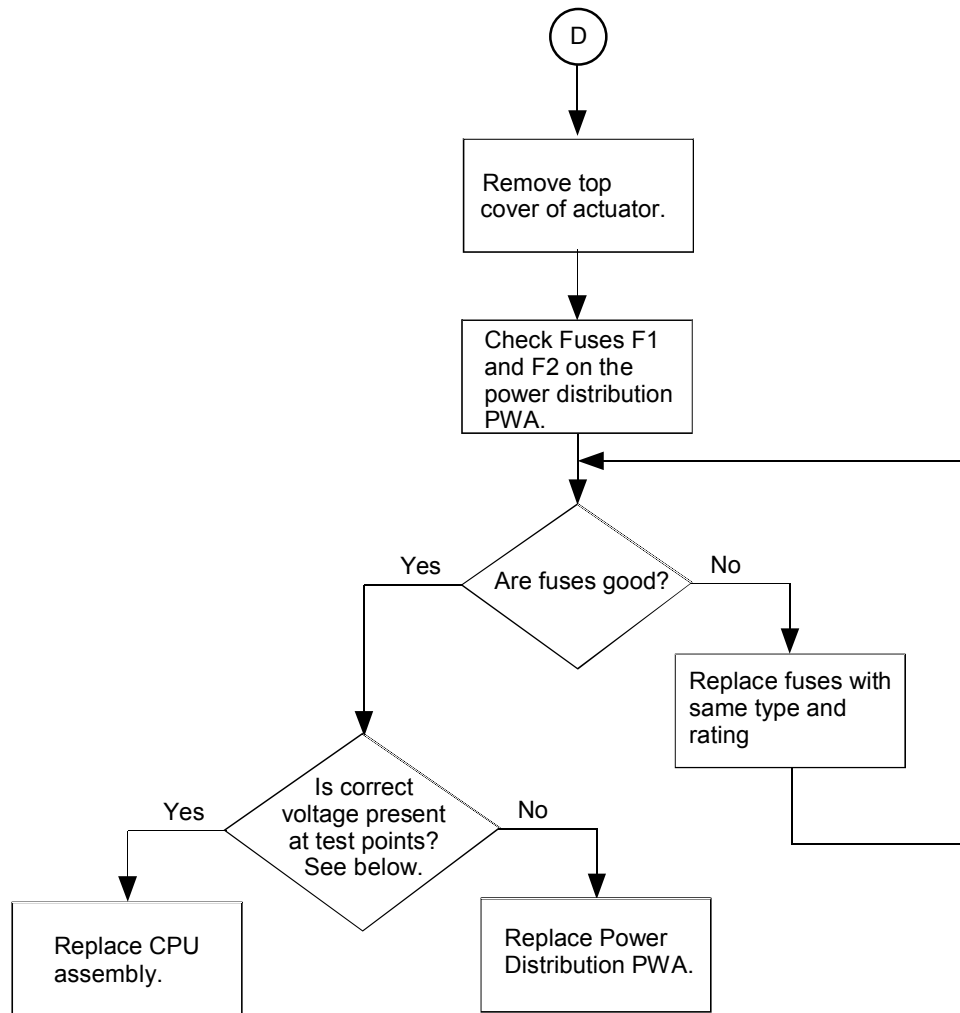

**Figure 43 Power Up Diagnostics**

**Test Non-Contact Sensor PWA**

See page 85.

**Test Power Distribution PWA**

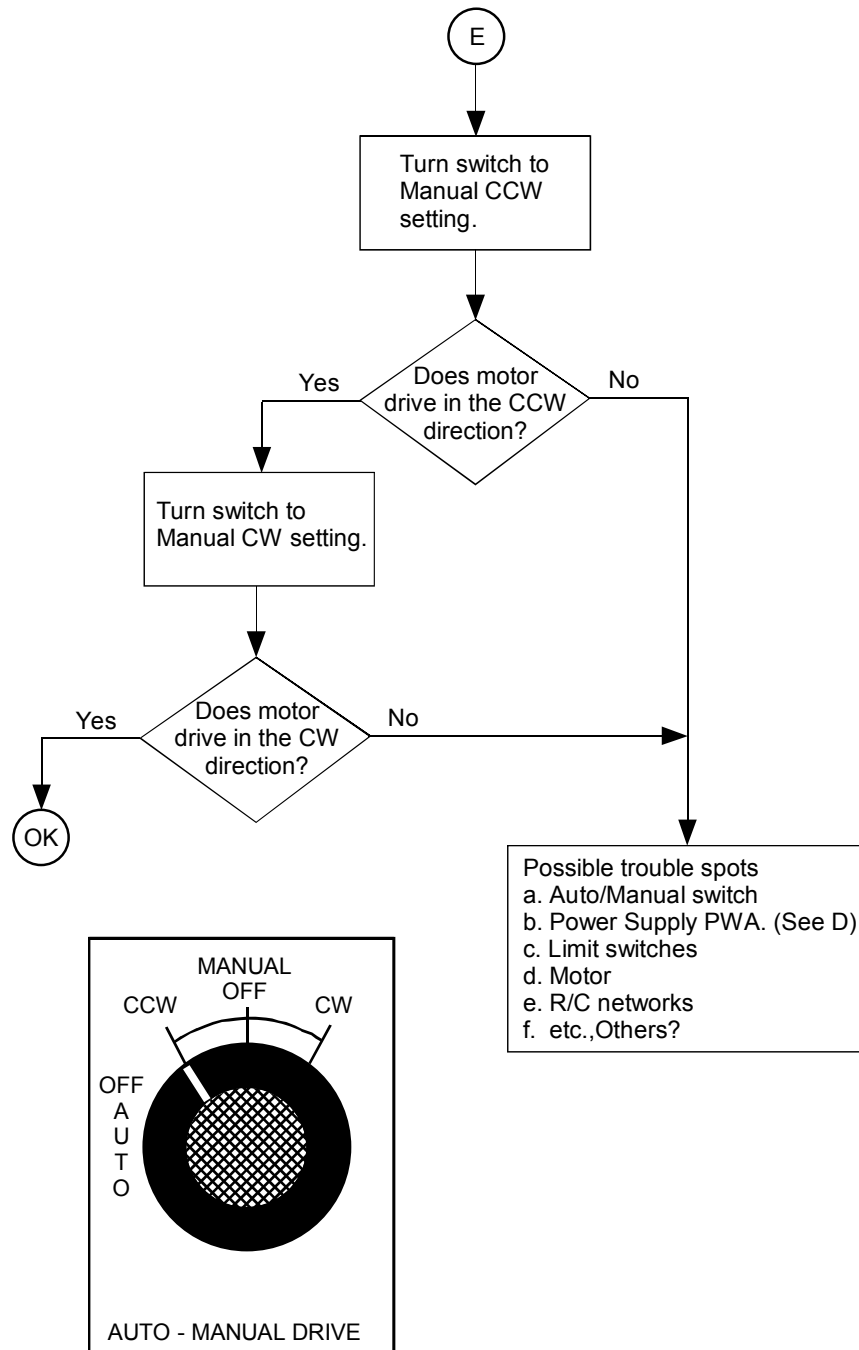

**Figure 44 Test Power Distribution PWA**

**Power Distribution PWA Test Points**

Connector	Test Points - Pins	Voltage
J2	Pin 1 to pin 7	5 V
J3	Pins 1,2 to pins 3, 4, 8	5 V
	Pins 3, 4 to pin 7	9 V
J1	Pins 5, 6 to pins 7, 8	24 V
	Pins 1, 2 to pins 7, 8	28 V + or – 3V

**Test AUTO - MANUAL DRIVE Switch**



**Figure 45 Test AUTO - MANUAL Switch**

### Test Relay Function

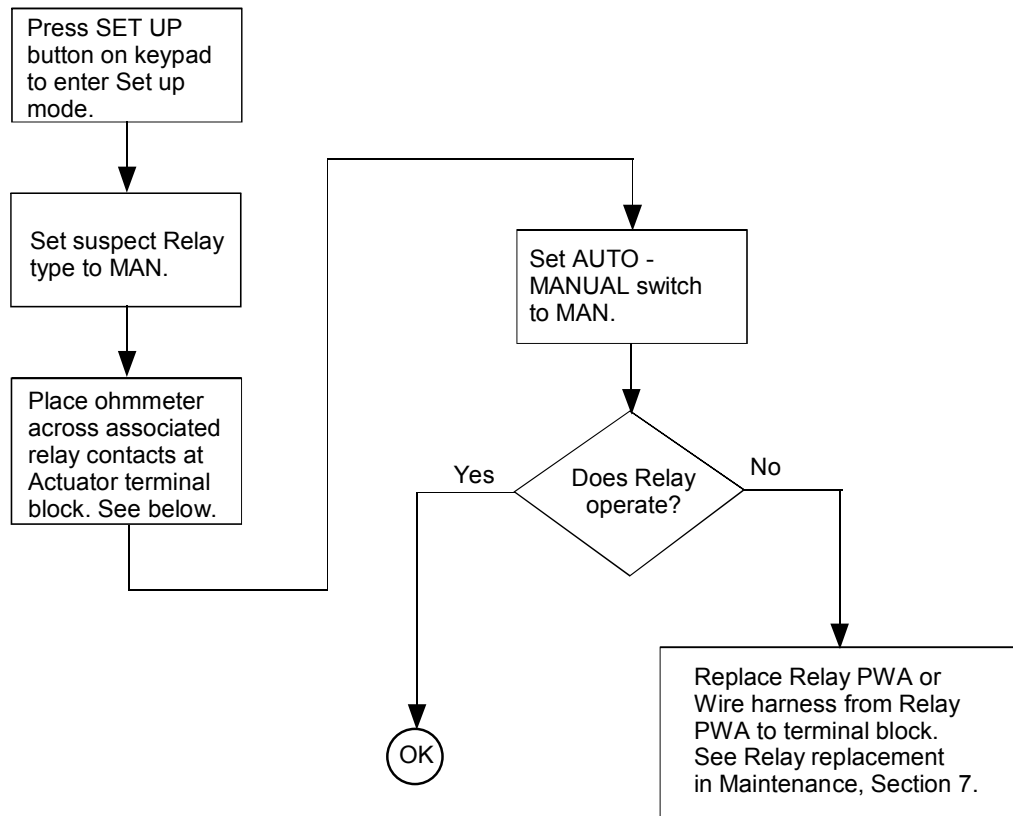

**Figure 46 Test Relay Function**

Relay	Associated Contacts
RELAY1	NC COM NO
RELAY2	NC COM NO
RELAY3	NC COM NO
RELAY4	NC COM NO

## Appendix A - HercuLine® 2001/2002 Configuration Record Sheet

Enter the value or selection for each set up parameter on this sheet so you will have a record of how your actuator is configured.

Set Up Group Prompt	Parameter	Setting	Default
SET INPUT	IN TYP - Input Actuation Type	_____	See Note 1
	INP HI – Input High Range Value	_____	100
	INP LO – Input Low Range Value	_____	0.0
	FILTYP – Input Filter Type	_____	LPAS
	LPFILT – Low Pass Filter Time Constant *	_____	0
	Direct – Actuator Rotation	_____	CCW
	Dband – Input Deadband	_____	0.5
	FSTYPH – Failsafehi Type	_____	UP
	FSVALH – Failsafehi Input Value	_____	100
	FSTYPL – Failsafelo Type	_____	DOWN
	FSVALL – Failsafelo Input Value	_____	0
	CHAR – Input Characterization type	_____	LINR
	CUSTOM -- Custom characterization type	_____	EQU
	X0 VAL -- User configurable characterizer value	_____	0.0
	X1 VAL -- User configurable characterizer value	_____	5.0
	X2 VAL -- User configurable characterizer value	_____	10.0
	X3 VAL -- User configurable characterizer value	_____	15.0
	X4 VAL -- User configurable characterizer value	_____	20.0
	X5 VAL -- User configurable characterizer value	_____	25.0
	X6 VAL -- User configurable characterizer value	_____	30.0
	X7 VAL -- User configurable characterizer value	_____	35.0
	X8 VAL -- User configurable characterizer value	_____	40.0
	X9 VAL -- User configurable characterizer value	_____	45.0
	X10 VAL - User configurable characterizer value	_____	50.0
	X11 VAL - User configurable characterizer value	_____	55.0
	X12 VAL - User configurable characterizer value	_____	60.0
	X13 VAL - User configurable characterizer value	_____	65.0
	X14 VAL - User configurable characterizer value	_____	70.0
X15 VAL - User configurable characterizer value	_____	75.0	
X16 VAL - User configurable characterizer value	_____	80.0	
X17 VAL - User configurable characterizer value	_____	85.0	
X18 VAL - User configurable characterizer value	_____	90.0	



Set Up Group	Parameter	Setting	Default
Prompt			
	X19 VAL - User configurable characterizer value	_____	95.0
	X20 VAL - User configurable characterizer value	_____	100.0
	Y0 VAL -- User configurable characterizer value	_____	0
	Y1 VAL -- User configurable characterizer value	_____	0.8
	Y2 VAL -- User configurable characterizer value	_____	2.1
	Y3 VAL -- User configurable characterizer value	_____	3.2
	Y4 VAL -- User configurable characterizer value	_____	4.9
	Y5 VAL -- User configurable characterizer value	_____	6.5
	Y6 VAL -- User configurable characterizer value	_____	8.4
	Y7 VAL -- User configurable characterizer value	_____	10.7
	Y8 VAL -- User configurable characterizer value	_____	13.2
	Y9 VAL -- User configurable characterizer value	_____	15.7
	Y10 VAL - User configurable characterizer value	_____	18.7
	Y11 VAL - User configurable characterizer value	_____	22.6
	Y12 VAL - User configurable characterizer value	_____	27.2
	Y13 VAL - User configurable characterizer value	_____	33.4
	Y14 VAL - User configurable characterizer value	_____	40
	Y15 VAL - User configurable characterizer value	_____	46
	Y16 VAL - User configurable characterizer value	_____	53.8
	Y17 VAL - User configurable characterizer value	_____	63.2
	Y18 VAL - User configurable characterizer value	_____	73.7
	Y19 VAL - User configurable characterizer value	_____	86.2
	Y20 VAL - User configurable characterizer value	_____	100
SET RELAY	RTYP11 – Relay Type	_____	NONE
	R11VAL – Relay Value	_____	0
	R11 HL – Relay High/Low	_____	LO
	R11SCALE– Relay Scale	_____	X1
	RTYP12 – Relay Type	_____	NONE
	R12VAL – Relay Value	_____	0
	R12 HL – Relay High/Low	_____	LO
	R12SCALE– Relay Scale	_____	X1
	RLY1HY – Relay Hysteresis	_____	0
	RTYP21 – Relay Type	_____	NONE
	R21VAL – Relay Value	_____	0
	R21 HL – Relay High/Low	_____	LO
	R21SCALE– Relay Scale	_____	X1
	RTYP22 – Relay Type	_____	NONE
	R22VAL – Relay Value	_____	0
	R22HL– Relay High/Low	_____	LO
	R22SCALE– Relay Scale	_____	X1
	RLY2HY – Relay Hysteresis	_____	0

Set Up Group Prompt	Parameter	Setting	Default
	RTYP31 – Relay Type	_____	NONE
	R31VAL – Relay Value	_____	0
	R31 HL – Relay High/Low	_____	LO
	R31SCALE– Relay Scale	_____	X1
	RTYP32 – Relay Type	_____	NONE
	R32VAL – Relay Value	_____	0
	R32HL– Relay High/Low	_____	LO
	R32SCALE– Relay Scale	_____	X1
	RLY3HY – Relay Hysteresis	_____	0
	RTYP41 – Relay Type	_____	NONE
	R41VAL – Relay Value	_____	0
	R41 HL – Relay High/Low	_____	LO
	R41SCALE– Relay Scale	_____	X1
	RTYP42 – Relay Type	_____	NONE
	R42VAL – Relay Value	_____	0
	R42HL– Relay High/Low	_____	LO
	R42SCALE– Relay Scale	_____	X1
	RLY4HY – Relay Hysteresis	_____	0
SET CUROUT	CUROUT - Output Signal Range	_____	See Note 1
SET COMM	COMM – Communications Parameters	_____	MODBUS
	ADDRES – Device Address	_____	1
	BAUD – Baud Rate	_____	19.2K
	XmtDLY – Response Delay	_____	20MS
	DBLBYT – Floating Point Data Format	_____	FP B
SET DIGINP	DIGINP – Digital Input State	_____	UP
	Endpos – End Position Value	_____	0
SET DISPLA	DECMAL – Decimal Point Location	_____	8888
	EUNITS – Units Display	_____	Pcnt
	UNITS – Display Units	_____	ENG
SET LOCK	LOCKID – Password Lock	_____	0
	MAENAB – Enabled	_____	ENAB
	LOCK – Lock Out	_____	NONE
READ STATUS	FAILSF – Failsafe	_____	Read Only
	RAMTST – RAM Test Diagnostic	_____	Read Only
	SEETST – Serial EEPROM Test Diagnostic	_____	Read Only
	CFGTST – Configuration Test Diagnostic	_____	Read Only
	CALTST – Calibration Test Diagnostic	_____	Read Only

Set Up Group Prompt	Parameter	Setting	Default	
SET DRVINF	VERSION – Firmware Version	_____	Read Only	
	SPEED – Stroke Speed	_____	Factory Set	
	POWER – Power Input Voltage Line Frequency	_____	Factory Set	
	TAG – Tag Name	_____		
	MFGDAT – Manufacturing Date	_____	Factory Set	
	LREP – Date of Last Repair	_____	Factory Set	
	LCAL – Date of Last Field Calibration	_____	Factory Set	
	REPTYP – Repair Type	_____	Factory Set	
SET MAIN	TEMP – Actuator Temperature	_____	Read Only	
	TEMPHI – High Temperature Limit	_____	Read Only	
	TEMPLO – Low Temperature Limit	_____	Read Only	
	ACST – Accumulated Stall Time	_____	Read Only	
	STARTS – Accumulated Motor Starts	_____	Read Only	
	RLnCNTS – Relay Cycle Counts n = 1, 2, 3, or 4	_____	Read Only	
	REGNy – Accumulated Motor Starts for regions of motor travel. y = 0 through 9	_____	Read Only	
	DATSAV – Forced maintenance data save	_____	DIS	
	MANRST – Maintenance Statistic Reset	_____	NONE	
	LDCAL – Restore Factory Calibration Type	_____	NONE	
	LDCFG – Restore Factory Default Configuration	_____	DIS	
	RESTRT – System Restart	_____	DIS	
	CAL NCSOUT	NCSOUT – Non-contact sensor circuit output	_____	Read Only

Note 1: Type is set from model number.

---

# Index

## A

- Actuator Rotation, 40, 64
- Actuator Set Up, 33
  - Set up groups, 34
  - Set up procedure, 36
- Actuator Statistics
  - Accumulated motor starts, 59
  - Motor starts, 59
  - Relay cycle counts, 59
  - Reset, 60
  - Temperature limits, 59
  - Total degrees of motor travel, 59
- Applications
  - Basic flow control, 27
  - Proportional flow with multiple actuators, 27
  - Split range, 26, 30
- Approvals, 6
- Auto/Manual Switch
  - Testing, 110
- Auto-Manual Switch, 64
- Auxiliary Switches, 81
  - Setting, 81
- Auxiliary Switches/Relays, 6

## B

- Baud Rate, 9, 50
- Burner Control/Flame Safety, 23

## C

- Calibration, 65
  - Set up, 66
- Calibration Values
  - Restore, 61
- CE Wiring, 21
- Change Password
  - LOCKID parameter, 54
- Clamp Bolt, 6
- Communications, 7, 9
  - Floating point data transfer, 50
- Configuration Prompt Hierarchy, 38
- Configuration Record Sheet, 112
- Configuration Tips, 33
- Connections
  - Output, 23
  - Slidewire emulation, 23
- Crank Arm, 5
- Crank Arms, 16
- Customer Connections, 17
- CW and CCW Direction. *See* Actuator Rotation

## D

- Deadband, 7, 40
- Decimal Point Location, 52
- Deviation, 45
  - Relay type, 47
- Device Address, 50
- Direction of Rotation, 7
- Duty Cycle, 7

## E

- Electrical and Performance Specifications, 6
- Electrical Installation, 17
- Enclosure, 5
- Enclosure Rating, 6
- End of travel Limit Switches, 6
- Exiting Set Up mode, 33

## F

- Failsafe, 40, 41
- Failsafe Input Value, 40, 41
- Failsafe operation, 7
- Feedback, 6
- Flame Safety Module wiring diagram, 23
- Fuses
  - Replacement, 89

## G

- Gear Train, 5

## H

- Handwheel, 5
- HercuLine 2000 Terminal Connections, 18
- HercuLine 2001/2002 with Auto/Manual Terminal Connections, 19
- HercuLine 2003 Wiring Connections and Operation, 20
- Hysteresis, 7, 44

## I

- Input Calibration, 68
- Input Characterization, 41
- Input Filters, 7, 40
- Input High Range, 39
- Input Impedance, 6
- Input Low Range, 39
- Input Set Up Group, 39
- Input Signal Connections, 22
- Input Signals, 6

Inputs, 39  
 Installation, 12  
 Installation Considerations, 13  
 Isolation, 6

## K

Keypad, 8, 31  
 Description, 32

## L

LEDs on Local Display, 32  
 Limit Switches, 78  
 Setting, 78  
 Linkage Kits, 96  
 Linkage Set-up, 15  
 Constant torque, 15  
 Crank arms, 16  
 Variable torque, 15  
 Load Requirement, 6  
 Local Auto/Manual Switch, 6  
 Local Display, 8, 31  
 Description, 31  
 LEDs description, 32  
 Operating displays, 84  
 Set up, 52  
 LOCK parameter, 33, 36  
 Lubrication, 5  
 Main (Worm) gear, 87  
 Spur gear, 87

## M

Main Gear Lubrication, 87  
 Mains Supply, 6  
 Mechanical Installation, 15  
 Mechanical Stops, 5  
 Modbus communications, 50, 85  
 Model distinctions, 1  
 Motor, 6  
 Motor Calibration, 70  
 Motor Current, 6  
 Motor Speed, 56  
 Motor Stall, 84  
 Motor Starts, 45  
 Relay type, 48  
 Mounting, 13

## N

Non-Contact Sensor, 87  
 Checking, 108  
 Operation, 85  
 Non-Contact Sensor Output Calibration, 72, 73

## O

Operating Temperature, 7

Output Calibration, 71  
 Output Shaft, 5  
 Output Torque, 5  
 Output Type, 49  
 Outputs, 49

## P

Password, 60  
 (LOCKID), 53  
 Change, 54  
 PDA, 9  
 Position Range  
 Relay type, 46  
 Position sensing, 7  
**POSITION SENSOR OUTPUT**, 63  
 Power Supply PWA  
 Checking, 109  
 Product Description, 1  
 Programmable Functions, 8  
 Pushbuttons  
 Description, 32

## R

Regions of Motor Travel, 62  
 REGN parameter, 59  
 Relative Humidity, 5  
 Relay Function  
 Testing, 111  
 Relay PWA Replacement, 90  
 Relay Type, 44, 45  
 Remote Setpoint Operation, 85  
 Repeatability, 7  
 Restore Factory Calibration Values, 61  
 Rotation, 5

## S

Scale, 5  
 Scrolling through Set Up Groups, 33  
 Self-test Diagnostics, 55, 83, 108  
 Sensitivity, 7  
 Set Up and Calibration Procedures, 31  
 Set Up Groups  
 Communications, 50  
 Current out, 49  
 Digital input, 51  
 Display, 52  
 Drive, 56  
 Input, 39  
 Lock, 53  
 Maintenance, 59  
 Read status, 55  
 Relays, 44  
 Slidewire Emulation, 23  
 Solid State Motor Control, 7  
 specifications, 5  
 Split Range, 26  
 Spur Gear Lubrication, 87

Stall, 84  
Start Up Checklist, 83  
Storage Temperature, 5  
Stroke Speed, 56

## **T**

Tag Name, 58  
TAG parameter, 56  
Technical and Operating Specifications, 5  
Temperature Coefficient, 7  
Terminal Connections, 18, 19  
Total Degrees of Motor Travel  
TOTDEG parameter, 59  
Troubleshooting, 105

Equipment, 106

## **V**

Voltage/ Supply Stability, 7

## **W**

Weight, 5

## **Z**

Zero Suppression, 7



# Honeywell

---

Honeywell Process Solutions  
Industrial Measurement and Control  
512 Virginia Drive  
Fort Washington, PA 19034

62-86-25-10 0708 Printed in USA

<http://hpsweb.honeywell.com>

---