

L404A-D,F; L604A,L,M Pressuretrol® Controllers

L404 and L604 Pressuretrol® Controllers are line voltage pressure controllers that provide operating control, automatic limit protection, or manual reset limit protection for pressure systems of up to 300 psi (21.1 kg/cm² or 2068 kpa).

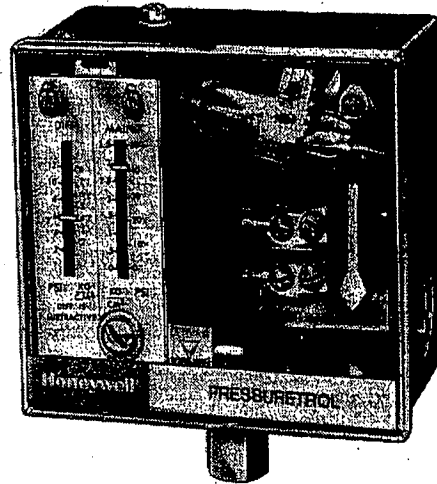

- Can be used with steam, air, non-combustible gases, or fluids non-corrosive to the pressure sensing element.
- Stainless steel diaphragm (except 300 psi [21.1 kg/cm² (2068 kPa)] models) also allows use with ammonia, oxygen, distilled water, and similar media.
- L404B is recommended for supervision of atomizing medium pressure in oil burner systems.
- Models are available with spst, spdt, or dpst switching and in variety of operating ranges.
- Dustproof, trouble-free mercury switches (all models except L404F, which has snap-acting switch).
- Automatic reset models have adjustable, subtractive differential (except L604M).
- Trip-free mechanism on manual reset models assures that limit function of controller cannot be defeated by jamming reset lever.
- Screw adjustments made on top of case.
- Scaleplates marked in English (psi) and Metric (kg/cm²) units.
- L404F models available with European enclosure, British Standard Pipe Threads, ground screw, and scaleplates marked in kg/cm² and either psi or kPa.
- Clear plastic cover on case to observe pressure settings and switch action.
- Leveling indicator visible through cover.
- Hexagonal fitting with 1/4-18 NPT internal threads for direct mounting to 14026 Steam Trap (siphon loop).
- Surface mount is available using screws through holes (knockouts) in case backing.

CONTENTS

Specifications	2
Ordering Information	2
Installation	5
Setting and Checkout	8
Service Information	10



Specifications

TRADELINE® MODELS

TRADELINE® models are selected and packaged to provide ease of stocking, ease of handling, and maximum replacement value. Specifications of TRADELINE® controls are the same as those of standard models except as noted below.

TRADELINE® MODELS AVAILABLE:

L604A Pressuretrol® Controllers—Available in 2 to 15, 5 to 50, 10 to 150, and 20 to 300 psi (.14 to 1.1 kg/cm² [14 to 103 kPa], .4 to 3.5 kg/cm² [34 to 345 kPa], .7 to 10.6 kg/cm² [69 to 1034 kPa], and 1.4 to 21.0 kg/cm² [138 to 2068 kPa]).

ADDITIONAL FEATURES: TRADELINE® pack with cross-reference label.

STANDARD MODELS

MODELS: L404A-D,F and L604A,L,M Pressuretrol® Controllers. See Table 1. A 14026 Steam Trap (siphon loop)

is available, except where noted in Table 1. The steam trap is necessary for boiler installations.

SWITCH(ES): Mercury switch(es) in all models except the L404F, which has a Micro Switch snap-acting switch.

PRESSURE SENSING ELEMENT: Stainless steel diaphragm (brass bellows in 300 psi [21.1 kg/cm², (2068 kPa)] models).

MAXIMUM AMBIENT TEMPERATURE: 150°F (66°C).

MINIMUM AMBIENT TEMPERATURE: Minus 35°F (minus 37°C); also refer to the note in the Location and Mounting section.

ADJUSTMENT MEANS: Screws on top of controller case. Scales are marked in psi and kPa.

ELECTRICAL CONNECTIONS: Internal screw terminals; hole in side of case for 1/2 in. conduit.

MOUNTING MEANS: Hexagonal fitting on diaphragm has 1/4-18 NPT internal threads for mounting on a pipe or steam trap (siphon loop). Also can be surface-mounted using screws through two holes (knockouts) in back of case.

Ordering Information

When purchasing replacement and modernization products from your TRADELINE® wholesaler or distributor, refer to the Tradeline Catalog or price sheets for complete ordering number, or specify—

1. Order number (TRADELINE® model, if desired).
2. Operating range (see Table 1).
3. Model without steam trap, if desired and available (see Table 1, Note b).
4. Optional specifications, if desired (see Table 1).
5. Replacement parts, if desired.
6. Accessories, if desired.

If you have additional questions, need further information, or would like to comment on our products or services, please write or phone:

1. Your local Home and Building Control Sales Office (please check the white pages of your phone directory).
2. Home and Building Control Customer Logistics
Honeywell Inc., 1885 Douglas Drive North
Minneapolis, Minnesota 55422-4386 (612) 951-1000

In Canada—Honeywell Limited/Honeywell Limitée, 740 Ellesmere Road, Scarborough, Ontario M1P2V9. International Sales and Service Offices in all principal cities of the world. Manufacturing in Australia, Canada, Finland, France, Germany, Japan, Mexico, Netherlands, Spain, Taiwan, United Kingdom, U.S.A.

TABLE 1—MODELS AVAILABLE.

Model	Switching Action on Pressure Rise to Setpoint	Operating Ranges ^a			Midscale Subtractive Differential ^a (Adjustable)			Maximum Surge Pressure		
		psi	kg/cm ²	kPa	psi	kg/cm ²	kPa	psi	kg/cm ²	kPa
L404A	spst, breaks circuit	2 to 15 ^{bc}	.14 to 1.0	14 to 103	2 to 6	.14 to .41	14 to 4	50	3.5	345
		5 to 50	.35 to 3.5	34 to 345	4 to 12	.28 to .82	127 to 83	85	6.0	586
		10 to 150 ^b	.66 to 10.6	69 to 1034	8 to 16	.56 to 1.10	55 to 110	225	15.8	1550
		20 to 300 ^d	1.4 to 21.0	138 to 2068	15 to 40	1.04 to 2.76	103 to 276	500	35.2	3445
L404B ⁱ	spst, makes circuit	2 to 15 ^{d, e, f}	.14 to 1.1	14 to 103	2 to 6	.14 to .41	14 to 41	50	3.5	345
		5 to 50	.35 to 3.5	24 to 345	4 to 12	.28 to .82	27 to 83	85	6.0	586
		10 to 150 ^{eb}	.66 to 10.6	69 to 1034	8 to 16	.56 to 1.10	55 to 110	225	15.8	1550
		20 to 300 ^d	1.4 to 21.0	138 to 2068	15 to 40	1.04 to 2.76	103 to 276	500	35.2	3445
L404C	spst, breaks circuit	2 to 15	.14 to 1.0	14 to 103	manual reset (fixed, subtractive differential)			50	3.5	345
		5 to 50	.35 to 3.5	34 to 345	85	6.0	586			
		10 to 150	.66 to 10.6	69 to 1034	225	15.8	1550			
		20 to 300 ^d	1.4 to 21.0	138 to 2068	500	35.2	3445			
L404D	spst, makes circuit	2 to 15	.14 to 1.0	14 to 103	manual reset ^g (fixed, subtractive differential)			50	3.5	345
		10 to 150	.66 to 10	69 to 1068	225	15.8	1550			
L404F	spdt snap-acting switch, ^h makes R-W, breaks R-B	2 to 15	.14 to 1.0	14 to 103	2 to 6	.14 to .41	14 to 41	50	3.5	345
		5 to 50 ⁱ	.35 to 3.5	34 to 345	6 to 14	.41 to .97	41 to 97	85	6.0	586
		10 to 150	.66 to 10	69 to 1034	10 to 22	.69 to 15.2	60 to 152	225	15.8	1550
		20 to 300 ^d	1.4 to 21.0	138 to 2068	20 to 50	1.4 to 3.5	138 to 345	500	35.2	3445
L604A	2 isolated spst circuits, or 1 spdt, ^j makes R1-W, breaks R2-B	2 to 15 ^c	.14 to 1.0	14 to 103	2 to 6	.14 to .41	14 to 41	25	1.8	172
		5 to 50	.35 to 3.5	34 to 345	4 to 12	.28 to .82	27 to 83	85	6.0	586
		10 to 150	.66 to 10	69 to 1034	8 to 16	.56 to 1.10	55 to 110	225	15.8	1550
		20 to 300 ^d	1.4 to 21.0	138 to 2068	15 to 40	1.04 to 2.76	103 to 276	500	35.2	3445
L604L	spdt circuit makes R-W, breaks R-B	2 to 15	.14 to 1.0	14 to 103	manual reset ^g (fixed, subtractive differential)			25	1.8	172
L604M	spdt circuit makes R-W, breaks R-B	10 to 150	.66 to 10.1	69 to 1034	fixed: 3.5 psi (24.1 kPa)			225	15.8	1550

^a Scaleplates are marked in both psi and kg/cm²

^b Model available with special fixed low differential. Switch rated for 0.5A at 120 Vac.

^c L404A,B and L604A models are available with 1 to 6 psi midscale subtractive differential in 2 to 15 psi models.

^d Brass bellows replaces stainless steel diaphragm. Not suitable for use with ammonia, oxygen, or other corrosive materials.

^e Model available with minimum operating pressure of 1.25 psi (0.09 kg/cm² or 8.62 kPa) and minimum subtractive differential of 0.5 psi (0.035 kg/cm² or 3.45 kPa).

^f Model available with special fixed low differential. Switch rated for 0.5A at 120 Vac.

^g L404C,D and L604L models are designated as Manual Reset 2 controllers; the trip-free reset mechanism does not permit the controller to function as an automatic-reset device when the manual reset lever is held in the reset position. The subtractive differential is fixed at the minimum value of the adjustable differential of the L404A for each corresponding operating range.

^h L404F only; all other models have mercury switches.

ⁱ Model available with sealed bell crank adjustment.

^j Spst switches operate in unison; spdt action when jumper is installed between R1 and R2.

^k Also recommended for supervision of atomizing medium pressure (air or steam) in an oil burner system.

SWITCH CONTACT RATING (in amperes at 50/60 Hz):

Model	Load	120 Vac	240 Vac	120 Vdc	240 Vdc
L404A	Full Load	8.0	5.1	2.4	1.2
	Locked Rotor	48.0	30.6	24.0	12.0
	Noninductive ^e	10.0	5.0	5.0	2.0
L604A,L ^b	Full Load	8.0	5.1	2.0	1.0
	Locked Rotor	48.0	30.6	20.0	10.0
	Noninductive	10.0	5.0	8.0	4.0
L604M	Full Load	1.0	0.5	1.0	0.5

^a L404F (snap-acting) does not have non-inductive or dc ratings.

^b L604A and L have also been tested (and listed by Underwriters Laboratories Inc.) and breaking (not making) a load with a total rating of 9.8 A full load, plus 360 VA ignition, plus 250 VA pilot duty at 120 Vac.

SPECIFICATIONS

DIMENSIONS: See Fig. 1. See Fig. 2 for mounting steam trap (siphon loop).

WEIGHT: 2 IBC. (0.91 kg).

FINISH: Gray.

APPROVALS:

Underwriters Laboratories Inc. listed (L404A,B,C,D,F; L604A,L,M only): file no. MP466, vol.10; guide no. MBPR.

Canadian Standards Association certified (L404A,B,C,D,F; L604A,L only): file no. LR1620; guide no.400-E-0.

REPLACEMENT PARTS:

129178 Thermoplastic Cover.

14026 Steam Trap (siphon loop)—1/4 in. black iron pipe. Necessary for boiler installations.

ACCESSORIES:

33312B Knurled Adjustment Knob—with setscrew; fits on main scale pressure adjusting screw.

4074BWJ Limit Stop Assembly—to limit set point ranges; includes 129564 Range Stop, 107194 Range Stop Screw, and 23466 Wrench.

TABLE 2—CONVERSION TABLE (psi to kPa).

Operating Range			Subtractive Differential		
Scale-Plate (psi)	Equivalent		Scale-Plate (psi)	Equivalent	
	(kg/cm ²)	(kPa)		(kg/cm ²)	(kPa)
0 to 15	0 to 10	0 to 103	—	—	—
2 to 15	.14 to 1.0	14 to 103	1 to 6 2 to 6	.07 to .4 .14 to .4	7 to 41 14 to 41
5 to 50	.3 to 3.5	34 to 345	4 to 12 5 to 14	.3 to .8 .4 to 1.0	28 to 83 41 to 97
5 to 150	.3 to 10.3	34 to 1034	—	—	—
10 to 150	.7 to 10.3	69 to 1034	8 to 16 10 to 22	.6 to 1.1 .7 to 1.5	55 to 110 69 to 152
20 to 300	1.4 to 20.7	138 to 2068	15 to 40 20 to 50	1.0 to 2.8 1.4 to 3.5	103 to 276 138 to 345

Fig. 1—Mounting dimensions of the L404A,B,C,D,F and L604A,L,M Pressuretrol® Controllers, in in. (mm).

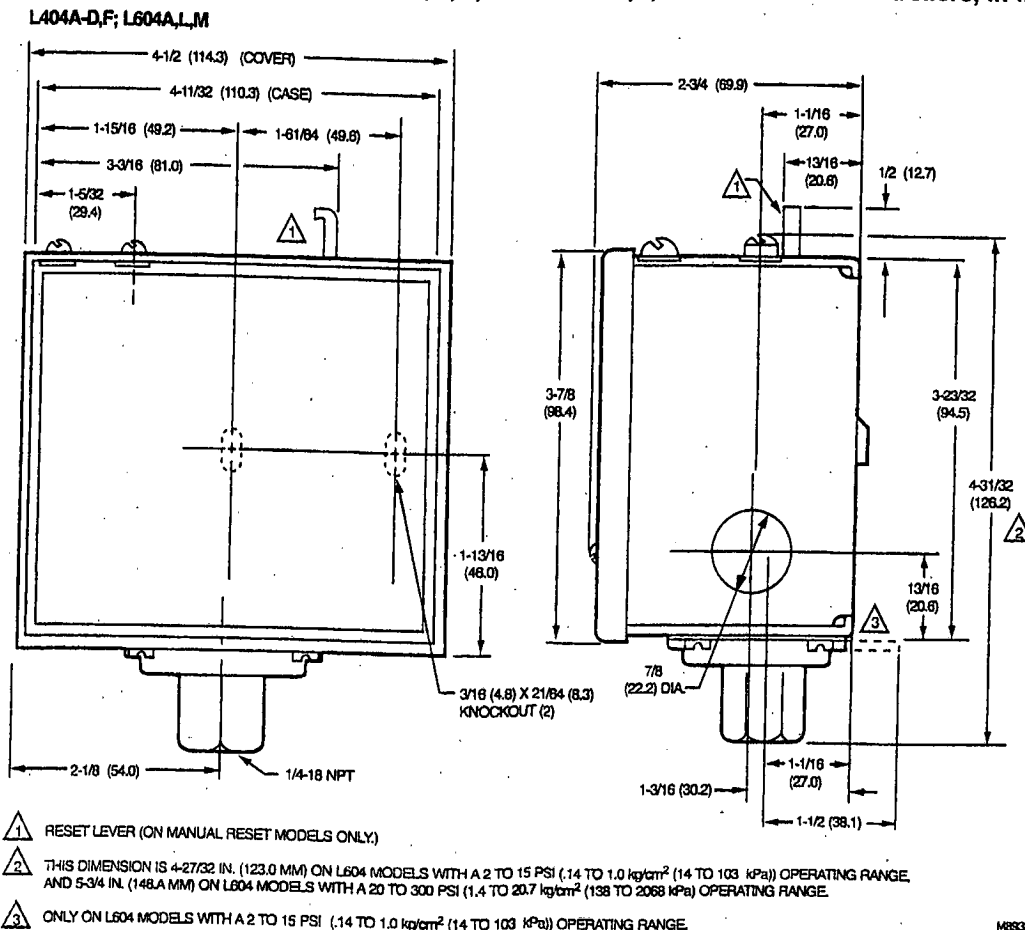

Installation

WHEN INSTALLING THIS PRODUCT...

1. Read these instructions carefully. Failure to follow them could damage the product or cause a hazardous condition.
2. Check the ratings given in the instructions and on the product to make sure the product is suitable for your application.
3. Installer must be a trained, experienced, flame safeguard control technician.
4. After installation is complete, check out product operation as provided in these instructions.

CAUTION

1. Disconnect power supply before beginning installation to prevent possible equipment damage or electrical shock.
2. When using the controller with a compressor, install a dampening device (such as a needle valve, header, or surge tank) to dampen pulsations that can damage the controller or reduce its life.

IMPORTANT:

1. Locate the controller where the ambient temperature will not exceed 150°F (66°C).
2. Use pipe compound sparingly to avoid clogging the hole in the pipe or diaphragm fitting.
3. Do not tighten the controller by hand by holding the case.
4. Accurately level the controller for proper operation.

LOCATION AND MOUNTING

NOTE: For most accurate operation; add supplemental heat to installations where the temperature falls below minus 20°F (minus 29°C). Never locate the controller where the temperature falls below minus 35°F (minus 37°C), because mercury in the switch freezes at this temperature.

When used with steam boilers, always mount the controller *above the water line* in the boiler. A steam trap (siphon loop) must always be connected between the controller and the boiler (Fig. 2) to prevent boiler scale and corrosive vapors from attacking the diaphragm. The loop on the steam trap must always be perpendicular to the face of the controller. If the loop is parallel to the controller, expansion or contraction of the loop tips the controller and causes the switch to operate inaccurately.

The controller can be mounted (1) alongside the pressure gauge, (2) in a fitting on the boiler provided by the manufacturer, (3) at a remote location in case of excessive vibration, or (4) in a special mounting on a low water cutoff.

Fig. 2—Right and wrong mounting of a steam trap (siphon loop), with approximate dimensions in in. (mm).

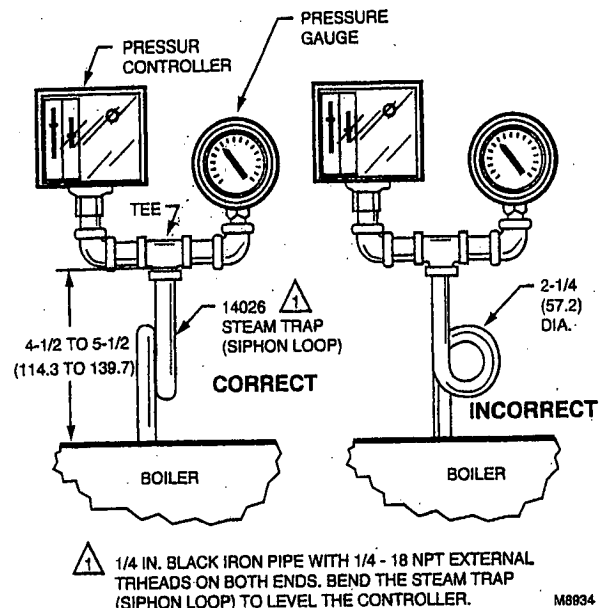

Make all pipe connections in accordance with approved standards. Use only a small amount of pipe compound to seal the connection joints. Excess pipe compound can clog the small hole in the fitting and prevent the controller from operating properly.

To avoid leaks and damage to the case, use a parallel jaw wrench on the controller's hexagonal fitting. *Do not tighten the controller by hand by holding the case.*

Leveling

A controller with a mercury switch must be accurately leveled for proper operation. It is level when the leveling indicator (Fig. 11) hangs freely with its pointer directly over the index mark inside the back of the case. Level the controller by carefully bending the steam trap (siphon loop).

Mounting Alongside a Pressure Gauge

To mount the controller *alongside a pressure gauge* (Fig. 2), remove the gauge. In its place, install a steam trap (siphon loop) with a tee on top. Using elbows and pipe nipples, mount the controller and pressure gauge on the ends of the tee. Level the controller after installation.

INSTALLATION

Mounting on a Boiler

If it is not convenient to mount the controller alongside the pressure gauge, install a steam trap (siphon loop) *in the fitting provided* by the boiler manufacturer. If there is no fitting, mount the steam trap at a location recommended by the boiler manufacturer. Screw the controller directly to the steam trap, and level the controller.

Mounting at a Remote Location

If there is *excessive vibration* at the boiler that can adversely affect the operation of the controller, mount the controller at a remote location. All piping from the boiler must be suitable and solidly mounted. The piping must be properly pitched to drain all condensation back to the boiler. A steam trap (siphon loop) must be mounted between the remote piping and the controller. Level the controller after installation.

Supervision of Atomizing Medium Pressure (Air or Steam)—L404B

When air or steam is used as an atomizing medium in an oil burner system, authorities having jurisdiction (approval bodies and codes) often require a low limit to prevent opening the main oil valve until sufficient atomizing pressure is present, and to shut down the system when the atomizing pressure falls too low.

The L404B is recommended for this application. It makes a circuit when the pressure rises to the set point, and breaks when the pressure falls to the set point minus the differential (Fig. 10).

WIRING

1. Disconnect the power supply before beginning wiring to prevent electrical shock or equipment damage.
2. Assume all wiring complies with applicable electrical codes, ordinances, and regulations. Use NEC Class 1 (line voltage) wiring.
3. For normal installations, use moisture-resistant No. 14 wire suitable for at least 167°F (75°C) when you are using the controller with a flame safeguard primary control, or at least 194°F (90°C) when using it with a programming control.
4. For high temperature installations, use moisture-resistant No. 14 wire, selected for a temperature rating above the maximum operating temperature.
5. All models have a terminal block inside the cover (Fig. 3 and 4) and a 7/8 in. (22.2 mm) hole in one side for 1/2 in. conduit, cable, or wires. Remove the front cover by loosening the screw at the bottom of the main scale.
6. Refer to Fig. 5 through 9 for typical hookups. Follow the burner or boiler manufacturer's wiring diagram if provided.
7. Make sure the loads do not exceed the Switch Contact Ratings in the Specifications section.
8. Replace the front cover when wiring is completed.

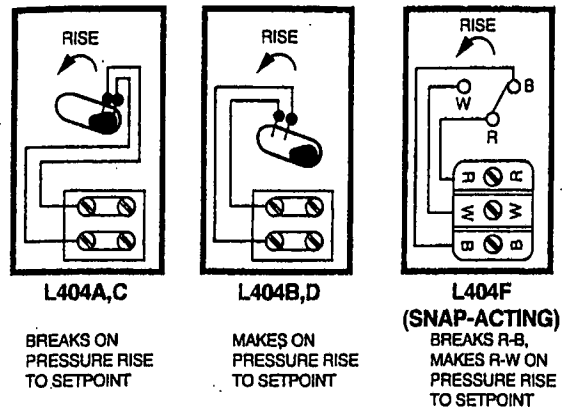
Fig. 3—L404 terminal blocks and internal schematics.

M8941

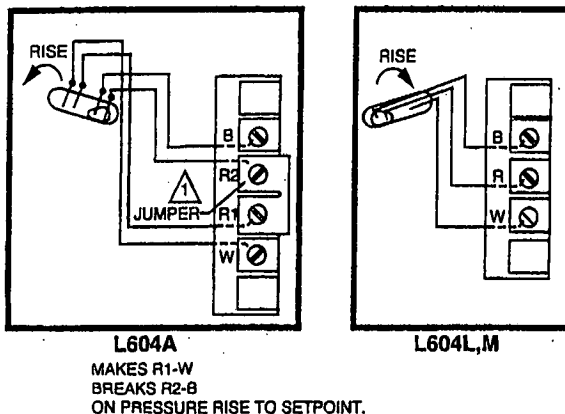
Fig. 4—L404 terminal block and internal schematic.

△ SPDT SWITCH ACTION WITH JUMPER INSTALLED; OTHERWISE, TWO ISOLATED SPST SWITCHES.

M8935

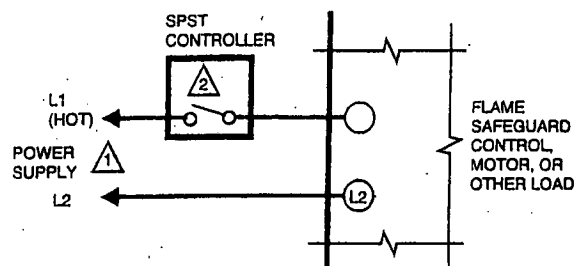
Fig. 5—L404 used as a limit or as an operating controller.

△1 PROVIDE DISCONNECT MEANS AND OVERLOAD PROTECTION AS REQUIRED.

△2 HIGH LIMIT—L404A OR C BREAKS WHEN PRESSURE RISES TO SETPOINT.
LOW LIMIT—L404B BREAKS WHEN PRESSURE FALLS TO SETPOINT MINUS DIFFERENTIAL.
OPERATING CONTROLLER—L404A BREAKS WHEN PRESSURE RISES TO SETPOINT, AND MAKES AGAIN WHEN PRESSURE FALLS TO SETPOINT MINUS DIFFERENTIAL.

M8936

Fig. 6—L404 with a low voltage relay.

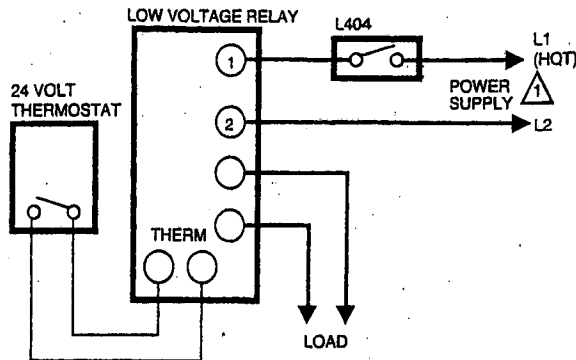

⚠ PROVIDE DISCONNECT MEANS AND OVERLOAD PROTECTION AS REQUIRED.

M8940

Fig. 7—L404F, L604A (jumper installed) used as a high limit, with an alarm circuit.

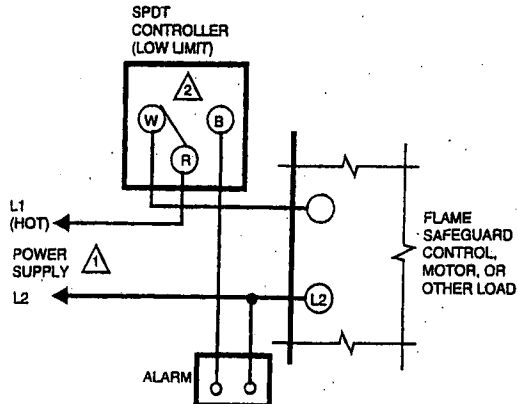

⚠ PROVIDE DISCONNECT MEANS AND OVERLOAD PROTECTION AS REQUIRED.

⚠ BREAKS R TO W AND MAKES R TO B WHEN PRESSURE FALLS TO SETPOINT MINUS DIFFERENTIAL.

M8937

Fig. 8—L404F, L604A (with jumper installed) or L604M, used as a low limit, with an alarm circuit.

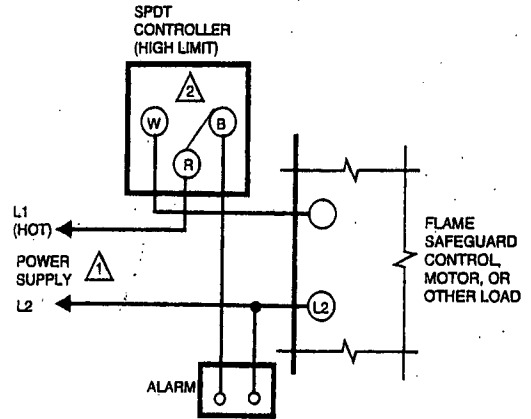

⚠ PROVIDE DISCONNECT MEANS AND OVERLOAD PROTECTION AS REQUIRED.

⚠ BREAKS R TO B AND MAKES R TO W WHEN PRESSURE RISES TO SETPOINT.

M8938

Fig. 9—L404F, or L604 with jumper installed, controlling an M644B motor.

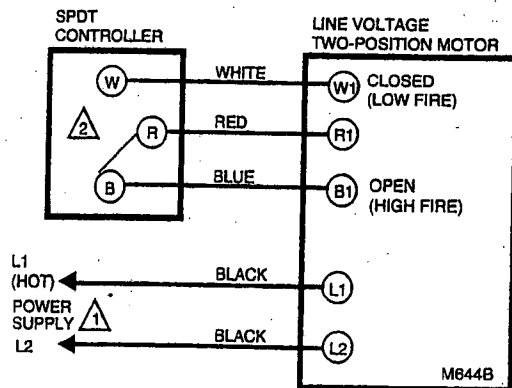

⚠ PROVIDE DISCONNECT MEANS AND OVERLOAD PROTECTION AS REQUIRED.

⚠ BREAKS R TO B AND MAKES R TO W WHEN PRESSURE RISES TO SETPOINT.

M8939

Setting and Checkout

SETTING

In all models, the differential is subtractive from the main scale set point. The upper operating point is determined by the main scale set point, while the lower operating point is determined by the main scale setting less the differential setting. The L404F and L604A (with jumper installed), L,M have spdt switching action. Operating points are shown in Fig. 10.

Fig. 10—L404 and L604 operating points.

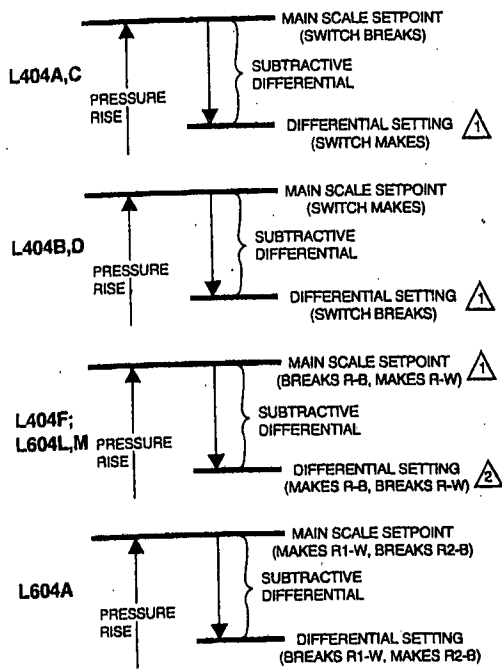

- ⚠ L404C,D and L604L MANUAL RESET MODELS HAVE A SMALL, FIXED DIFFERENTIAL. THEY CAN BE MANUALLY RESET WHEN THE PRESSURE FALLS TO THE MAIN SCALE SETPOINT MINUS THE DIFFERENTIAL.
- ⚠ L604M HAS A SMALL, FIXED DIFFERENTIAL OF 3.5 PSI (0.25 kg/cm²) OR 24.1 kPa.)

M8942

Adjust the main scale set point for the desired operating pressure by turning the main scale adjusting screw (Fig. 11) on the top of the case until the main scale setting indicator is at the desired value. On an L404A,B,F with a 5 to 150 psi (.3 to 10.3 kg/cm² [34 to 1034 kPa]) operating range, or an L604A, adjust the differential setting by turning the differential adjusting screw (Fig. 11) until the differential setting indicator is at the desired value. L404C,D and L604L are manual reset models: see the next paragraph. The L604M has a fixed differential. The scaleplates are marked psi and kg/cm².

Trip-Free Manual Reset Feature (L404C,D and L604L only)

The L404C breaks, the L404D makes, and the L604L makes R-W and breaks R-B when the pressure rises to the

main scale setpoint. They will not automatically return to their former positions. To reset one of these controllers, wait until the pressure falls to the set point minus the differential (Fig. 10). Then depress the manual reset lever (Fig. 11) and release it. The controller will not be reset until you release the manual reset lever. This prevents the controller from becoming an automatic-reset device if the reset lever is stuck, held in, or tied down.

Fig. 11—Setting a Pressuretrol® Controller.

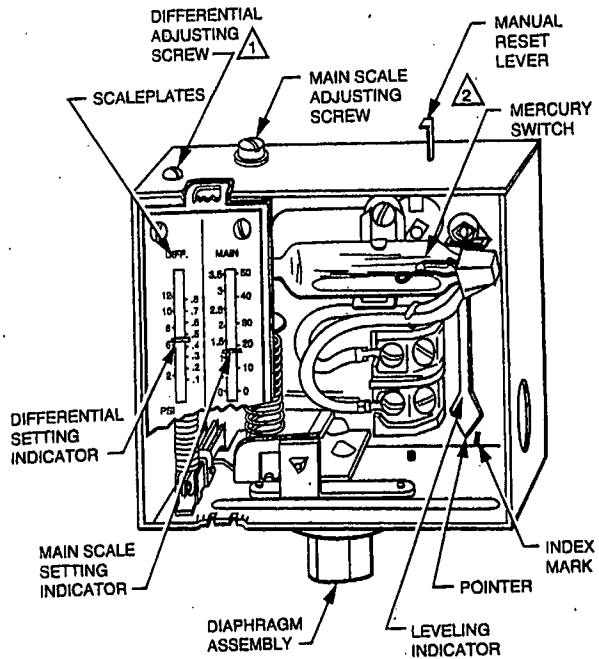

- ⚠ 1 ADJUSTABLE DIFFERENTIAL ON THE L404A,B,F; L404L WITH A 5 TO 150 PSI (0.34 TO 10.3 kg/cm² [34 TO 134 kPa]) OPERATING RANGE; AND L604A MODELS ONLY.
- ⚠ 2 TRIP-FREE MANUAL RESET LEVER ON THE L404C,D AND L604L MODELS ONLY.

M8943

CHECKOUT

After the controller has is installed, wired, and set, test it with the system in operation. First allow the system to stabilize. Then observe the operation of the controller while raising and lowering its setpoint. Pressure should increase when the setpoint is raised and decrease when the set point is lowered.

Also check the make and break points of the controller. If they do not agree with a separate, accurately calibrated pressure gauge, a slight adjustment of the scaleplate(s) may be necessary.

Use accurate pressure testing equipment when checking out the controller. Do not rely on inexpensive gauges. The controllers are carefully calibrated at the factory.

Boiler Installation

If the controller is being used on a boiler installation, test it as follows:

1. Note the boiler pressure by checking the boiler pressure gauge. (To perform this test properly, the boiler should have a pressure reading near the middle of the controller's main scale range.)

2. Turn the main scale adjusting screw (Fig. 11) until the main scale setting indicator on the controller corresponds to the boiler pressure gauge reading.

3. The L404A or C should break the control circuit(s) automatically when the boiler pressure gauge reading equals or slightly exceeds the controller setting.

The L404B or D should make the circuit under the same circumstances.

The L404F; L604L,M should make the R-W circuit and break the R-B circuit under the same circumstances.

The L604A should make the R1-W circuit and break the R2-B circuit under the same circumstances.

4. If the controller is operating properly, turn the main scale adjusting screw (Fig. 11) until the main scale setting indicator is at the desired set point.

If a Controller Seems to Operate Improperly

If the controller is suspected of operating improperly, it may be further checked as follows (Fig. 12):

1. Disconnect all power to the controller, loosen the cover screw, and remove the cover.

2. Disconnect the wires from the controller.

3. Connect an ohmmeter between the switch terminals.

4. Lower the set point of the controller (simulating a pressure increase) through a range greater than the differential. The switch should either make or break, depending on the model of the controller. (An L404A or C should break, an L404B or D should make, an L404F; L604L,M should break R-B and make R-W, and an L604A should break R2-B and make R1-W.) If it makes, the ohmmeter reads zero; if it breaks, the ohmmeter reads infinity.

5. Raise the set point of the controller (simulating a pressure decrease) through a range greater than the differential. The switch should break or make, just the opposite of its action in step 4 (except for the L404C,D and L604L manual reset models).

NOTE: An approximation of the differential can be made by observing the change in set point required for a resistance change from zero to infinity.

6. If the controller operates improperly, replace it.

7. When the controller is operating properly, reconnect the wires to the terminal block, replace the cover and tighten the cover screw, and reconnect the power.

CAUTION

Do not put the system into service until you have satisfactorily completed all applicable tests described in this Checkout section, in the Checkout section of the applicable instructions for the flame safeguard control, and any others required by the burner and boiler manufacturers.

Fig. 12—Checking controller operation using an ohmmeter:

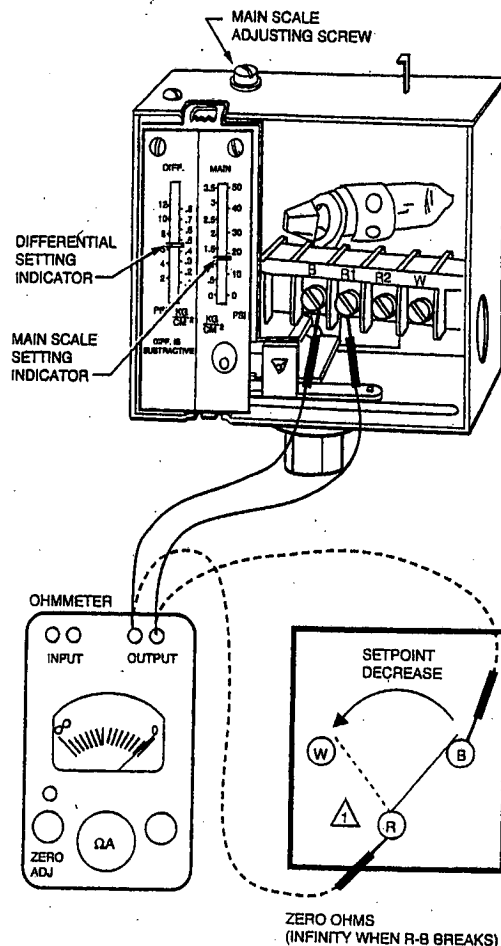

 AN L604, WITH JUMPER INSTALLED BETWEEN R1 AND R2, IS SHOWN; AN L404F OPERATES SIMILARLY (SPDT SWITCHING). AN L404A, B, C OR D HAS ONLY TWO TERMINALS (SPST SWITCHING); AN L404A OR C BREAKS AND L404B OR D MAKES WHEN THE SETPOINT IS DECREASED FAR ENOUGH.

Service Information

CALIBRATION

The controller was carefully calibrated during manufacturing and should not require recalibration. Most calibration errors are caused by improper leveling. The controller should be level when the pointer on the leveling indicator is directly over the index mark (Fig. 11). In some cases, the leveling indicator may not be accurate enough. The pointer may be over the index mark, but the controller still may not be operating within the tolerance of its scale setting. In this case, carefully bend the steam trap (siphon loop) until the controller switches properly.

MAINTENANCE

The cover of the controller should be in place at all times to protect the internal components from dirt, dust, and physical damage. Routine maintenance should consist of occasional inspection and blowing or brushing away any accumulated dirt and dust. To ensure proper functioning of the controller at all times, perform an operational check of the entire system during routine maintenance checks.