

Honeywell

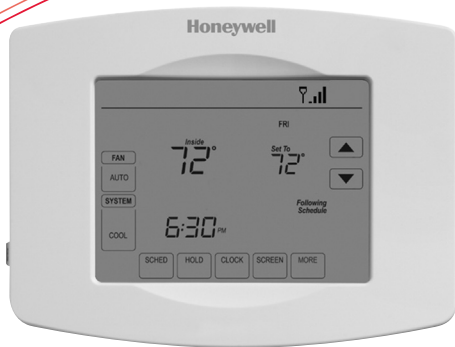

User Guide

Wi-Fi Touchscreen
Programmable Thermostat

Model RTH8580WF

In the box you will find

- Thermostat
- Wallplate (attached to thermostat)
- Screws and anchors
- Coin cell battery (inside the back of the thermostat)
- Quick Start Guide
- Thermostat ID Card
- Wire labels
- User Guide







Welcome

Congratulations on your purchase of a Honeywell Wi-Fi touchscreen programmable thermostat. When registered to Honeywell's Total Connect Comfort Solutions, you can remotely monitor and control the heating and cooling system in your home or business—you can stay connected to your comfort system wherever you go.

Honeywell's Total Connect Comfort is the perfect solution if you travel frequently, own a vacation home, a business or manage an Investment property or if you are simply looking for peace of mind.

 This thermostat works on 24 volt systems. It will NOT work on 120/240 volt systems.

 This thermostat contains a Lithium battery which may contain Perchlorate material. Perchlorate Material—special handling may apply. See www.dtsc.ca.gov/hazardouswaste/perchlorate

 **MERCURY NOTICE:** Do not place your old thermostat in the trash if it contains mercury in a sealed tube. Contact the Thermostat Recycling Corporation at www.thermostat-recycle.org or 1-800-238-8192 for information on how and where to properly and safely dispose of your old thermostat.

 **NOTICE:** To avoid possible compressor damage, do not run air conditioner if the outside temperature drops below 50°F (10°C).

Need help?

Visit wifithermostat.com or call 1-855-733-5465 for assistance before returning the thermostat to the store.

Table of contents

About your new thermostat

Home screen quick reference	5
Message center messages	6
Preset energy-saving schedules	8

Installation

Installing your thermostat.....	10
Connecting to your Wi-Fi network.....	27
Registering your thermostat online	32

Operation

Setting the clock.....	37
Setting the fan.....	38
Selecting system mode.....	39
Adjusting program schedules.....	40
Overriding schedules temporarily	41
Overriding schedules permanently	42

Setting vacation hold.....	43
Setting filter reminder intervals	44
Cleaning the screen	45
Unregistering thermostat.....	46
Disconnecting Wi-Fi	47
Special features	48
Setting functions and options.....	51

Appendices

Frequently asked questions	59
Troubleshooting.....	62
Limited warranty.....	68

Features of your Wi-Fi thermostat

With your new thermostat, you can:

- **Connect to the Internet to monitor and control your heating/cooling system**
- **View and change your heating/cooling system settings**
- **View and set temperature and schedules**
- **Receive alerts via email and get automatic upgrades**

Your new thermostat provides:

- **Smart Response Technology**
- **Compressor protection**
- **Heat/cool auto changeover**

Home screen quick reference

Once your Wi-Fi thermostat is installed, it will display the home screen. Portions of this display will change depending on how you are viewing it. To change settings, simply press the appropriate area lightly with your finger.

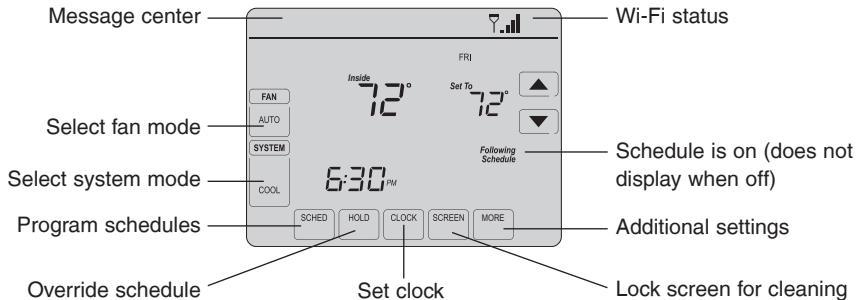



Unless you change the lighting function, the screen is always lit at low intensity. When you touch the screen, the screen brightens.

Message center messages

The Message Center at the top of the screen communicates Wi-Fi connection and registration status. It also displays the MAC ID and MAC CRC for registering the thermostat at mytotalconnectcomfort.com





Wi-Fi SETUP	Displayed before you begin Wi-Fi setup.
CONNECTING...	Displayed while connecting to the Wi-Fi network.
CONNECTION SUCCESSFUL	Displayed after connecting to the Wi-Fi network.
JOINED: [Wi-Fi network name]	Displayed when connected to the Wi-Fi network.
YOU ARE ALMOST DONE!	Displayed when Wi-Fi connection is complete.
CONNECTION FAILED	Displayed when the thermostat fails to establish a connection to the Wi-Fi network.
REGISTER AT TOTAL CONNECT	Displayed when the thermostat is connected to the Wi-Fi network but not registered at mytotalconnectcomfort.com
MAC: [Found on your ID card]	Displays the thermostat's MAC ID and MAC CRC for registering at mytotalconnectcomfort.com
CRC: [Found on your ID card]	

Message center messages

CONGRATULATIONS SETUP COMPLETE!	Displayed when the thermostat is registered at mytotalconnectcomfort.com
UNREGISTERED FROM TOTAL CONNECT	Displayed when the thermostat is removed from your Total Connect Comfort account.
	Wi-Fi signal strength. Displayed when the thermostat is connected to the Wi-Fi network and registered at mytotalconnectcomfort.com
	Displayed if there is no Wi-Fi signal.

Preset energy-saving schedules

This thermostat is pre-set with energy-saving program settings for four time periods. Using the default settings can reduce your heating/cooling expenses by as much as 33% if used as directed. Savings may vary depending on geographic region and usage.

		Default Heat Settings	Default Cool Settings
	WAKE 6:00 am	70°	78°
	LEAVE 8:00 am	62°	85°
	RETURN 6:00 pm	70°	78°
	SLEEP 10:00 pm	62°	82°

To change the settings, see pages 40–43.

Setting up your thermostat

Setting up your Wi-Fi programmable touchscreen thermostat is easy. It is preprogrammed and ready to go as soon as it is installed and registered.

- ① Install your thermostat.
- ② Connect it to your home wireless network.
- ③ Register online for remote access.

Before you begin, you may want to watch a brief installation video. Use the QR Code® at the front of this guide, or go to wifithermostat.com

Installing your thermostat

You might need the following tools to install this thermostat:

- No. 2 Phillips screwdriver
- Small pocket screwdriver
- Pencil
- Level (optional)
- Drill and bits (3/16" for drywall, 7/32" for plaster) (optional)
- Hammer (optional)
- Electrical tape (optional)

1 Switch OFF power.

To protect your equipment, switch OFF the power to your heating/cooling system at the breaker box or the system switch.

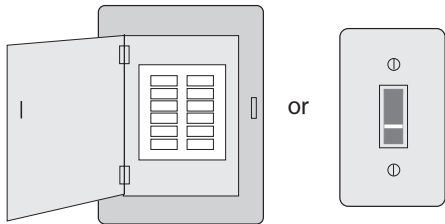

Installing your thermostat

2 Remove old thermostat.

Remove the old thermostat while leaving the wallplate and wiring in place.



If you have an older thermostat with a sealed mercury tube, turn to page 2 for proper disposal instructions.



Take a picture of the wires on your old thermostat for later reference.

Terminal designation

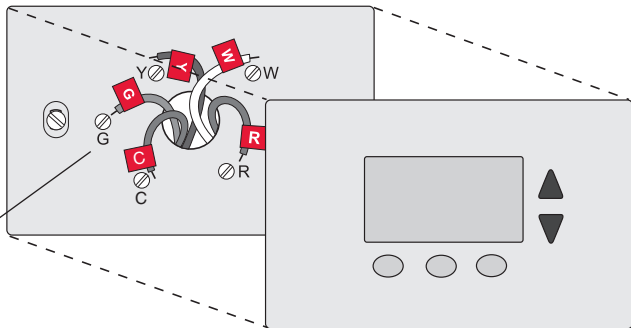

Installing your thermostat

3 Label wires.

Use the supplied sticky tags to label each wire as you disconnect it. Label wires according to the old thermostat terminal designations, not by wire color.

Note: If no tag matches a wire terminal label, write the terminal label on a blank tag.

Wiring Labels			Étiquettes de fils			Rótulos para los cables			
Apply these wiring labels to each wire with the appropriate terminal designation as you remove it from the existing thermostat.			Lorsque vous retirez les fils des bornes du thermostat existant, collez ces étiquettes sur chaque fil correspondant à la lettre de la borne.			Coloquez estos rótulos, con la designación de las terminales, en cada cable al remover los cables del termostato actual.			
B	B	Y2	Y2	C	C	E	E	F	F
G	G	H	H	L	L	O	O	P	P
R	R	RC	RC	RH	RH	T	T	U	U
V/VR	V/VR	W	W	W1	W1	W2	W2	W3	W3
X	X	X1	X1	X2	X2	Y	Y	Y1	Y1
AUX	AUX								

69-0823EFS-2 • 9-05 • Printed in U.S.A.

Blank tags

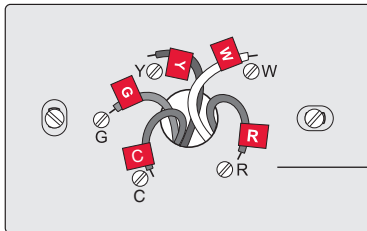

Terminal designation

Installing your thermostat

4 Remove wallplate.

Remove the old wallplate from the wall after all wires have been labeled and disconnected.

5 Separate Wi-Fi thermostat and its wallplate.

On your new thermostat, grasp the finger holds on the top and bottom of the wallplate with one hand and the thermostat (front) with the other hand. Pull pieces apart.

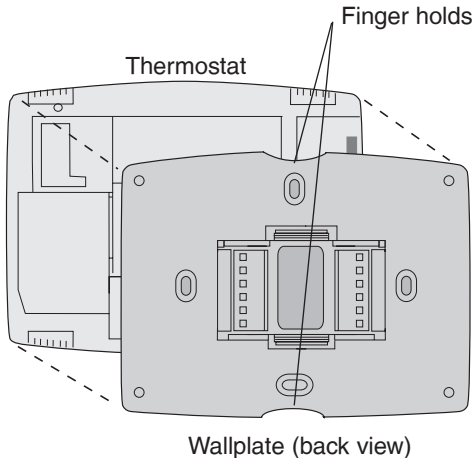

Installing your thermostat

6 Mount wallplate for Wi-Fi thermostat.

Mount your new wallplate using screws and anchors included with the thermostat.

If necessary:

Drill 3/16-in holes for drywall.

Drill 7/32-in holes for plaster.

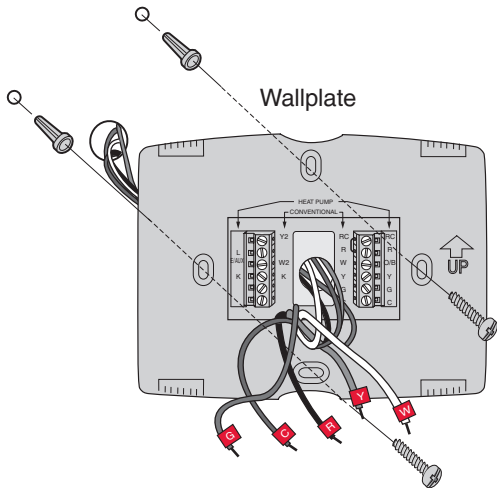

Installing your thermostat

Note: The Wi-Fi thermostat requires a C wire to operate. The C, or common, wire brings 24 VAC power to the thermostat. Many older mechanical or battery operated thermostats do not require a C wire. If you don't have a C wire, try:

- Looking for an unused wire that is pushed into the wall. Connect that wire to C and check that it is connected to the 24 VAC common at your heating/cooling system. Check the video section at wifithermostat.com
- Installing a new wire. If required, contact a contractor to install a new wire (go to wifithermostat.com to locate a contractor in your area).

Wiring

For **conventional** heating/cooling systems (natural gas, oil or electric furnace, air conditioner), see page 16. See “Glossary” on page 65 for further definition.

For a **heat pump** system, see page 17. See “Glossary” on page 65 for further definition.

Installing your thermostat

Wiring (conventional system)

7A Connect wires.

Wire the Wi-Fi thermostat to your conventional system.

- Match the labels on the wires to the terminal labels. You must have a C wire. See page 15.
- Loosen screws, insert wires into holes on inside edge of terminals, then tighten screws.
- Push any excess wire back into the wall opening.
- Continue to page 22.

 **Labels don't match?** See alternate wiring key on pages 18–19.

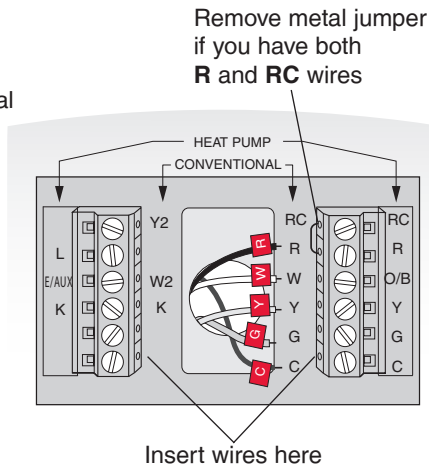

Installing your thermostat

Wiring (heat pump system only)

7B Connect wires.

Wire Wi-Fi thermostat to your heat pump.

- Match the labels on the wires to the terminal labels on the new thermostat. You must have a C wire. See page 15.
- Loosen screws, insert wires into holes on inside edge of terminals, then tighten screws.
- If old thermostat has separate wires on **AUX** and **E**, place both wires into the **E/AUX** terminal. If old thermostat has wire on **AUX** with a jumper to **E**, place wire on **E/AUX** terminal. No jumper is required.
- Push any excess wire back into the wall opening.
- Continue to page 22.



Labels don't match? See alternate wiring key on pages 20–21.

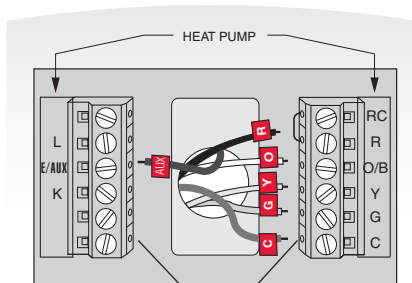

Insert wires here

Installing your thermostat

Alternate wiring (conventional system)

Use this if your wire labels don't match the terminal labels.

Note: You must have a C wire or equivalent. See page 15.

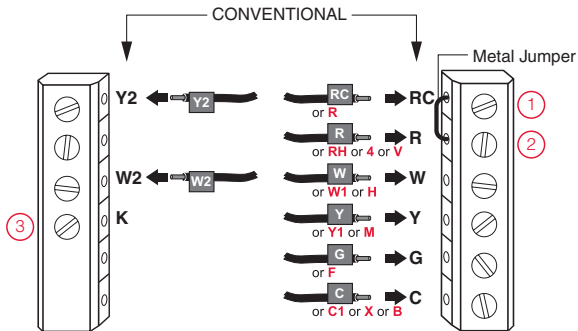

See key to ① – ③
on page 19.

Installing your thermostat

Alternate wiring key (conventional system)

- ① Remove metal jumper connecting **R** and **RC** *only* if you must connect both **R** and **RC**.
- ② If your old thermostat had both **R** and **RH** wires, remove metal jumper. Connect the **R** wire to the **RC** terminal, and the **RH** wire to the **R** terminal.
- ③ Do not use **K** terminal.

Installing your thermostat

Alternate wiring (heat pump system only)

Use this if your wire labels don't match the terminal labels.

Note: You must have a C wire or equivalent. See page 15.

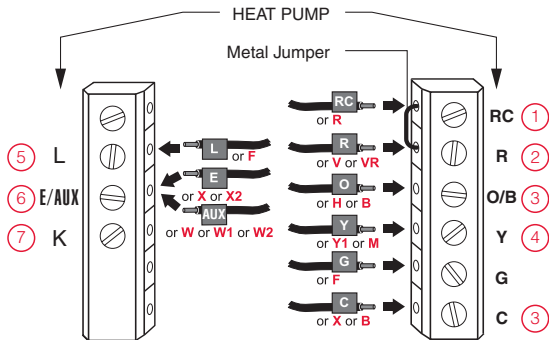

See key to (1) – (7)
on page 21.

Installing your thermostat

Alternate wiring key (heat pump system only)

- ① Leave metal jumper between **R** and **RC** terminals in place.
- ② If your old thermostat had both **V** and **VR** wires, check wifithermostat.com for help.
- ③ If your old thermostat had separate **O** and **B** wires, attach the **B** wire to the **C** terminal. If another wire is attached to the **C** terminal, check wifithermostat.com for help. Attach the **O** wire to the **O/B** terminal. Set System Function 0190 to 0 (see page 55).
If your old thermostat had an **O** wire and not a **B** wire, attach the **O** wire to the **O/B** terminal.
- ④ If your old thermostat had separate **Y1**, **W1** and **W2** wires, check wifithermostat.com for help.
- ⑤ This is the system monitor. If the monitor finds a problem, you will see a red light in the upper right corner of the thermostat (shines through the cover).
- ⑥ If old thermostat has separate wires on **AUX** and **E**, place both wires into the **E/AUX** terminal. If old thermostat has wire on **AUX** with a jumper to **E**, place wire on **E/AUX** terminal. No jumper is required.
- ⑦ Do not use **K** terminal.

Installing your thermostat

8 Install battery.

Insert the coin cell battery (included), observing the correct polarity.

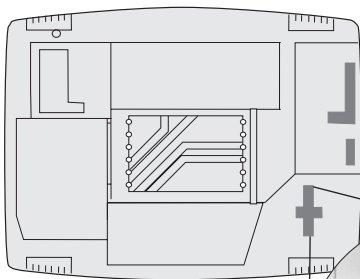

Thermostat interior



Installing your thermostat

9 Attach thermostat to wallplate.

Align the thermostat to the wallplate and then snap into place.

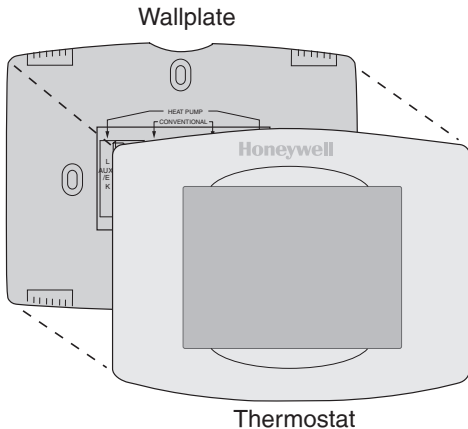

Installing your thermostat

10 Switch heating/cooling system ON.

Switch power back to ON for your heating/cooling system at the breaker box or the system switch.

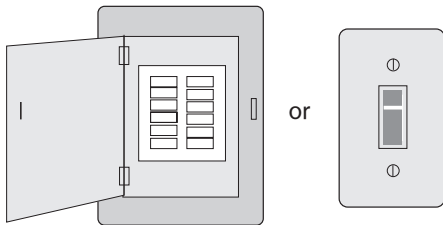

Installing your thermostat

11 Set date and time.

Touch ▲ or ▼ buttons to change displayed time and date.

Press and hold a button to quickly change a setting.

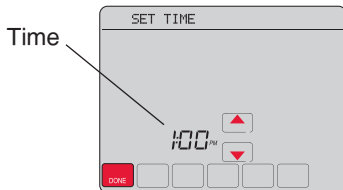
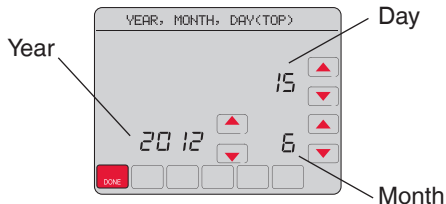

Installing your thermostat

12 Determine your heating/cooling system type.

If your system type is conventional single stage, continue to “Connecting to your Wi-Fi network” on page 27.

If your system is:

- Conventional multistage heat and cool
- Heat pump without backup heat
- Heat pump with backup heat
- Heat only
- Cool only

See page 51 to match your thermostat to your system type, then continue to “Connecting to your Wi-Fi network” on page 27.



If you are not sure of your heating/cooling system type or have other questions, go to wifithermostat.com

Connecting to your Wi-Fi network

To complete this process, you must have a wireless device connected to your home wireless network. Any of these device types will work:

- Laptop (recommended)
- Tablet (recommended)
- Smartphone

 **If you get stuck...** at any point in this procedure, restart the thermostat by removing the thermostat from the wallplate, wait for 5 seconds, and snap it back onto the wallplate. Return to Step 1 in this procedure, which starts on the next page.

Connecting to your Wi-Fi network

The message at the top of your thermostat must say Wi-Fi SETUP.

- 1 Connect to your thermostat.
 - 1a On your laptop, tablet or smartphone, view the list of available networks.
 - 1b Connect to the network called **NewThermostat_123456** (the number will vary).

Note: If you are asked to specify a home, public, or office network, select **Home Network**.

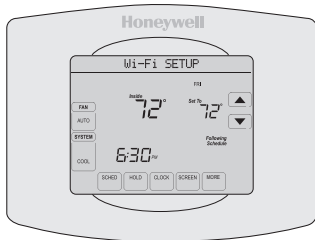

Connecting to your Wi-Fi network

Note: If your Wi-Fi network does not appear in the list on the Thermostat Wi-Fi Setup page:

- Try performing a network rescan by pressing the Rescan button. This is helpful in areas with a lot of networks.
- If you are connecting to a hidden network, then enter the network SSID in the textbox, select the encryption type from the drop down menu, and click on the Add button. This manually adds the network to the top of the list. Click on the new network in the list and enter the password if necessary. Click on Connect to join the network.

Connecting to your Wi-Fi network

- 3 Make sure your thermostat is connected.

Notice the thermostat message center. It will display **CONNECTING...** for up to 30 seconds, then **CONNECTION SUCCESSFUL** for one minute.

Then you will see **YOU ARE ALMOST DONE!**

If you don't see these messages, see page 27.

To register online for remote access to your thermostat continue on page 32.

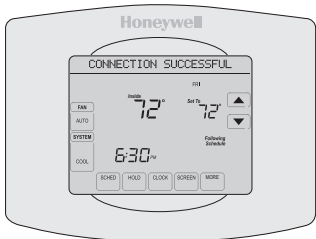
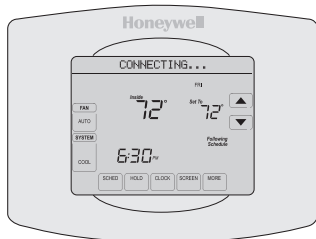

Registering your thermostat online

To view and set your Wi-Fi thermostat remotely, you must have a Total Connect Comfort account. Use the following steps.

- 1 Open the Total Connect Comfort web site.

In an Internet browser, on your wireless device, open the Total Connect Comfort web site: mytotalconnectcomfort.com

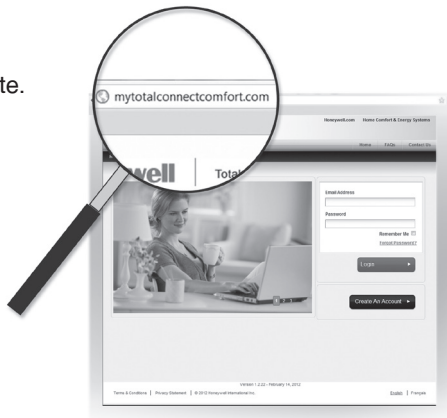

Registering your thermostat online

2 Login or create an account.

If you have an account,
click **Login**

– or –

click **Create An Account**

2a Follow the instructions on the screen.

2b **Check your email** for an activation
message from My Total Connect
Comfort.

2c **Follow activation instructions** in the
email.

2d Log in.



Registering your thermostat online

3 Register your Wi-Fi thermostat.

After you are logged in to your Total Connect Comfort account, register your thermostat. Follow the instructions on the screen. After adding your thermostat location, you must enter the thermostat's:

- MAC ID
- MAC CRC

These IDs are listed on the Thermostat ID Card included with the thermostat, in the message center during this step, and on the interior of the thermostat. The IDs are not case sensitive.

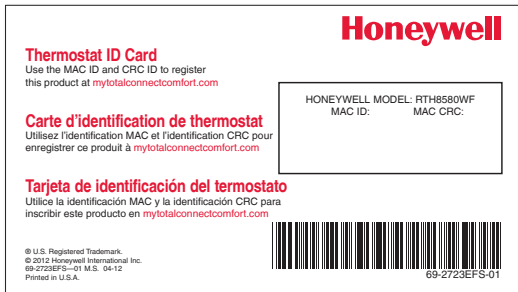

Honeywell

Thermostat ID Card
Use the MAC ID and CRC ID to register this product at mytotalconnectcomfort.com

Carte d'identification de thermostat
Utilisez l'identification MAC et l'identification CRC pour enregistrer ce produit à mytotalconnectcomfort.com

Tarjeta de identificación del termostato
Utilice la identificación MAC y la identificación CRC para inscribir este producto en mytotalconnectcomfort.com

HONEYWELL MODEL: RTH8580WF
MAC ID: MAC CRC:

© U.S. Registered Trademark.
© 2012 Honeywell International Inc.
69-2723EFS--01 M.S. 04-12
Printed in U.S.A.

69-2723EFS-01

Registering your thermostat online

When the thermostat is successfully registered, the Total Connect Comfort registration screen will display a SUCCESS message.

In the thermostat message center you will see: CONGRATULATIONS SETUP COMPLETE!

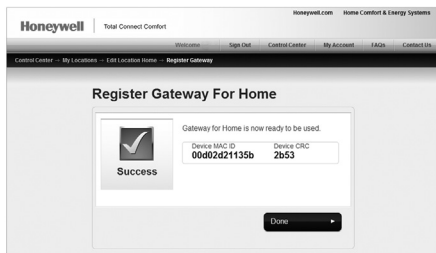

Registering your thermostat online

Your thermostat will display wireless signal strength.

You can now control your thermostat from anywhere through your laptop, tablet, or smartphone.



Total Connect Comfort free app is available for Apple® iPhone®, iPad® and iPod touch® devices at iTunes® or at Google Play® for all Android™ devices.

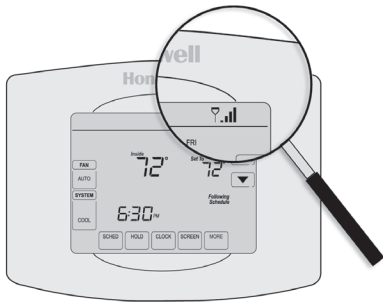

Setting the clock

- 1 Press **CLOCK** to display setting arrows.
- 2 Press ▲ or ▼ to adjust the time. (You can advance the time more quickly by holding the ▲ or ▼ buttons.)
- 3 Press **DONE** to save and exit (or press **CANCEL** to exit without changing the time).

Note: You should never need to adjust the real-time clock; it automatically updates for daylight saving time and all date/time information is stored.

Note: To change the current week day format, see “Schedule Options” on page 53.

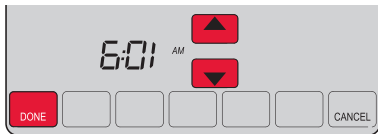

Setting the fan

- 1 Press **FAN** to select fan operation.
- 2 Press **FAN** again to select **ON** or **AUTO** (toggle to re-select). The selected option blinks.
- 3 Press **DONE** to save setting. Your selection appears under **FAN**.

ON: Fan is always on.

AUTO: Fan runs only when the heating or cooling system is on.

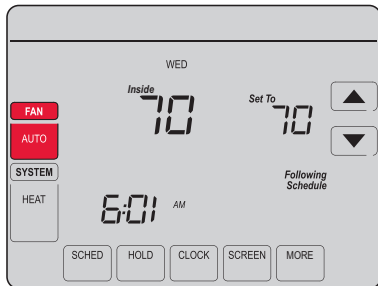

Selecting system mode

- 1 Press **SYSTEM** to display options.
- 2 Press **SYSTEM** again to select an option.
You may need to press two or three times to make a selection—the selected option blinks.
- 3 Press **DONE** to save setting.

Possible system modes:

HEAT: Controls only the heating system.

COOL: Controls only the cooling system.

OFF: Heating/cooling systems are off.

AUTO: Selects heating or cooling depending on the indoor temperature.

EM HEAT (heat pumps with aux. heat):
Controls auxiliary/emergency heat.
Compressor is locked out.

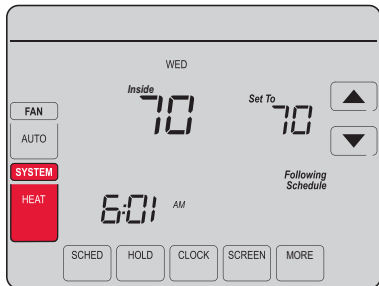

Note: The **AUTO** and **EM HEAT** system settings may not appear, depending on how your thermostat was installed.

Adjusting program schedules

- 1 Press **SCHED**, then **EDIT**. Screen displays day buttons at top.
- 2 Press day buttons (**MON–SUN**) to select days.
- 3 Press ▲ or ▼ to set Wake time for selected day(s).
- 4 Press ▲ or ▼ to set Heat and Cool temperature for this time period.
- 5 Press another period (**LEAVE, RETURN, SLEEP**) and set time and temperatures for each.
- 6 Press **DONE** to save and exit (or press **CANCEL** to exit without saving changes).

Note: You can press **CANCEL PERIOD** to eliminate any unwanted time period.

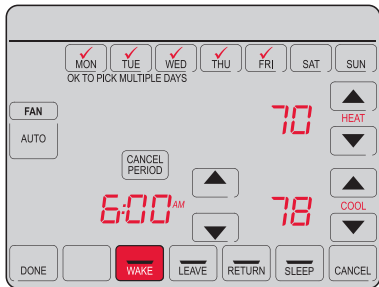

Overriding schedules temporarily

- 1 On the home screen, press ▲ or ▼ to immediately adjust the temperature.
- 2 Adjust the time to when you want the hold to end (the default is the end of the current period).

The new setting will be maintained until the time shown under *Hold Until*. When the timer expires, the schedule will resume, and the temperature will return to the setting for the current time period.

To cancel the temporary setting at any time, press **CANCEL** (or **SCHED**). The program schedule will resume.

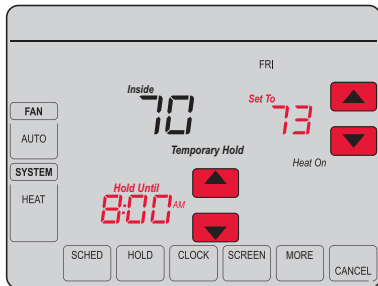

Overriding schedules permanently

- 1 Press **HOLD** to permanently adjust the temperature. This will turn off the program schedule.
- 2 Whatever temperature you set will be maintained 24 hours a day until you manually change it or press **CANCEL** (or **SCHED**) to cancel “Hold” and resume the program schedule.

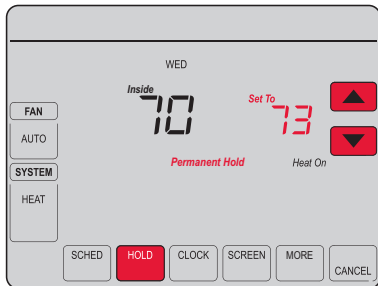

Setting vacation hold

Use this function to suspend the program schedule while you are away for an extended period.

- 1 Press ▲ or ▼ to set the temperature.
- 2 Press ▲ or ▼ to set the time of day you want the schedule to resume on the day you return.
- 3 Press **HOLD** twice. *Hold Until* appears.
- 4 Press ▲ or ▼ to select the number of days.

The selected temperature will be maintained 24 hours a day for the number of days you select. After the selected number of days has elapsed, the previously programmed schedule will resume at the time you set.

Note: You can press **CANCEL** (or **SCHED**) to resume normal schedule.

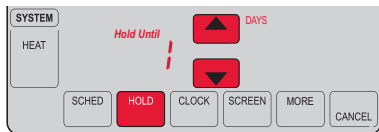
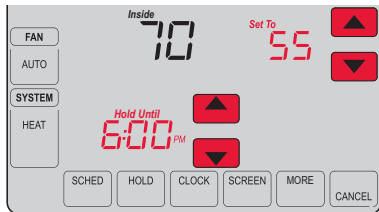

Setting filter reminder intervals

If activated during installation, the filter reminder alerts you with a message above the time when it is time to replace your filter.

Press **RESET** after changing the filter, to restart the timer.

To change the reminder interval:

- 1 Press **MORE**, then **EDIT**.
- 2 Press **▲** or **▼** to select the desired interval (in days), then press **DONE**.
- 3 Press **RESET**.
- 4 Press **DONE** to save and exit.

Note: System setting function 0500 governs the filter interval. See “Filter Change Reminder” on page 57.

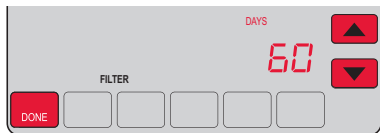
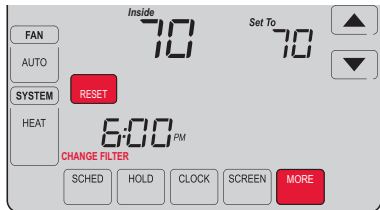

Cleaning the screen

- 1 Press **SCREEN** to lock the screen for cleaning. The screen will remain locked for 30 seconds so you can clean the screen without changing any settings.
- 2 After 30 seconds, press **DONE** to resume normal operation, or press **SCREEN** again if you require more time for cleaning.

Note: Do not spray any liquid directly on the thermostat. Spray liquid onto a cloth, then use the damp cloth to clean the screen. Use water or household glass cleaner. Avoid abrasive cleansers.

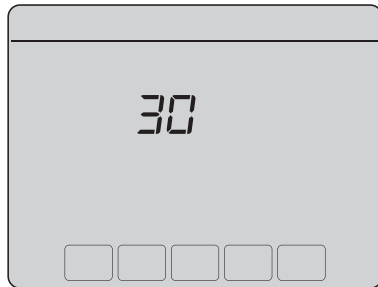

Unregistering thermostat

If you remove the thermostat from your Total Connect Comfort website account (for example, you're moving and leaving the thermostat behind), the message center will scroll UNREGISTERED FROM TOTAL CONNECT for 3 minutes.

After that, it will alternate displaying REGISTER AT TOTAL CONNECT, the MAC ID and the MAC CRC.

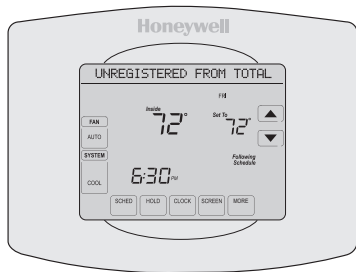

Disconnecting Wi-Fi

If you disconnect the thermostat from your Wi-Fi network (for example, you're replacing your router):

- 1 Enter system setup (see page 51).
- 2 Change setting 900 to 0 (see page 58).

The Message Center will display Wi-Fi DISCONNECTED for 1 minute.

After that it will display Wi-Fi SETUP.

Re-connect to a Wi-Fi network by following the steps on page 27.

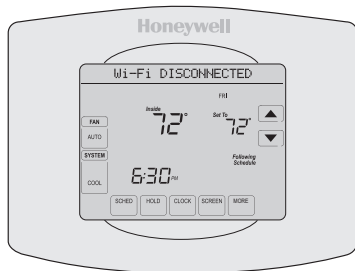

Smart Response Technology

This feature allows the thermostat to “learn” how long the heating/cooling system takes to reach programmed temperature settings, so the temperature is reached at the time you set.

For example: Set the Wake time to 6:00 am, and the temperature to 70°. The heat will come on *before* 6:00 am, so the temperature is 70° by 6:00 am.

Note: System setting function 0530 controls Smart Response Technology. See “Smart Response Technology” on page 57.

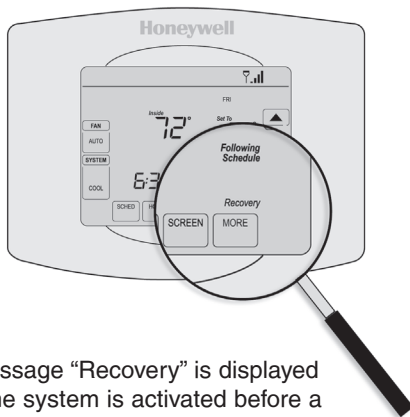

The message “Recovery” is displayed when the system is activated before a scheduled time period.

Compressor protection

This feature forces the compressor to wait a few minutes before restarting, to prevent equipment damage.

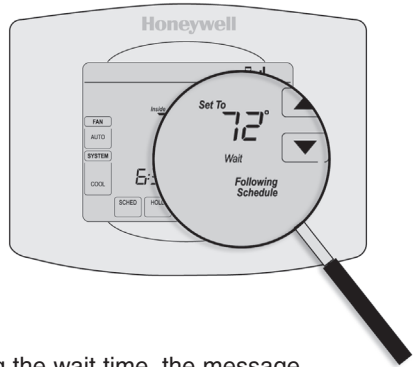

During the wait time, the message “Wait” is displayed on screen.

Auto changeover

This feature is used in climates where both air conditioning and heating are used on the same day.

When the system is set to **AUTO**, the thermostat automatically selects heating or cooling depending on the indoor temperature.

Heat and cool settings must be at least 3 degrees apart. The thermostat will automatically adjust settings to maintain this 3-degree separation.

Note: System setting function 0300 controls Auto changeover. See “Manual/Auto Changeover” on page 56.

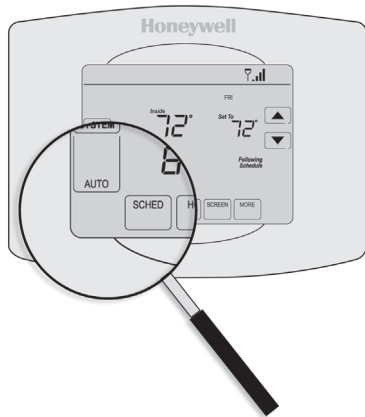

Setting functions and options

You can change options for a number of system functions. Available functions depend on the type of system you have. The functions, designated with four-digit numbers, along with available options are described on pages 52–58.

This thermostat is pre-set for a single-stage heating/cooling system. Setting function 0170 for a heat pump will adjust the default settings.

- 1 Press **SYSTEM**. You'll see several blank buttons on the bottom of the display.
- 2 Press and hold the center blank button until the screen changes (approximately 5 seconds).
- 3 Cycle through the functions, press ▲▼ next to the four digit number on the left.
- 4 As needed, change options for any function by pressing ▲▼ next to the number on the right.
- 5 When you have made all changes, press **DONE** to save and exit.



System setup

How do I set my thermostat name? (See page 51 for instructions.)

Function	Settings & Options			
0112 Device Name This name will identify the thermostat when you view it remotely. If you register multiple thermostats, give each one a different name.	52 = Thermostat			
	1 Basement	16 Exercise Room	30 Library	44 Porch
	2 Bathroom	17 Family Room	31 Living Room	45 Rec Room
	3 Bathroom 1	18 Fireplace	32 Lower Level	46 Sewing Room
	4 Bathroom 2	19 Foyer	33 Master Bath	47 Spa
	5 Bathroom 3	20 Game Room	34 Master Bed	48 Storage Room
	6 Bedroom	21 Garage	35 Media Room	49 Studio
	7 Bedroom 1	22 Great Room	36 Music Room	50 Sun Room
	8 Bedroom 2	23 Guest Room	37 Nursery	51 Theater
	9 Bedroom 3	24 Gym	38 Office	52 Thermostat
	10 Bedroom 4	25 Kid's Room	39 Office 1	53 Upper Level
	11 Boat House	26 Kitchen	40 Office 2	54 Utility Room
	12 Bonus Room	27 Kitchen 1	41 Pantry	55 Walk In Closet
	13 Computer Room	28 Kitchen 2	42 Play Room	56 Wine Cellar
	14 Den	29 Laundry Room	43 Pool Room	57 Workshop
	15 Dining Room			

System setup

How do I change time and date settings? (See page 51 for instructions.)

Function	Settings & Options
0120 Year Setting (first two digits)	20 = Year 20xx 21 = Year 21xx
0130 Year Setting (last two digits)	01–99 (i.e., 2001–2099)
0140 Month Setting	01–12 (i.e., January–December)
0150 Date Setting	01–31
0160 Schedule Options	4 Program schedule is on (7-day programmable). 0 Program schedule is off. Thermostat can not be programmed.
0165 Restore Schedule Defaults	0 Continue using programmed schedule. 1 Restore thermostat program to energy saving settings

System setup

How do I set my heating/cooling system type? (See page 51 for instructions.)

Function	Settings & Options
0170 Select System Type If you are not sure of your heating/cooling system type or have other questions, go to wifithermostat.com	<ol style="list-style-type: none">1 Heat/cool: Gas, oil or electric heating <u>with</u> central air conditioning.2 Heat pump: Heat pump <u>without</u> backup or auxiliary heat.4 Heat only with fan: Gas, oil or electric heat <u>without</u> central air conditioning.5 Heat only (no fan): Gas, oil or hot water heat <u>without</u> central air conditioning.6 Cool only: Central air conditioning only.7 Heat pump: Heat pump <u>with</u> backup or auxiliary heating.8 Heat/Cool Multiple stages: 2 heat stages (wires on W and W2), 2 cooling stages (wires on Y and Y2).9 Heat/Cool Multiple stages: 2 heat stages (wires on W and W2), 1 cooling stage (wire on Y).10 Heat/Cool Multiple stages: 1 heat stage (wire on W), 2 cooling stages (wires on Y and Y2).

System setup

How do I customize my heating/cooling system? (See page 51 for instructions.)

Function	Settings & Options
0180 Heating Fan Control	<p>0 Gas or oil heat: Use this setting if you have a gas or oil heating system (system controls fan operation).</p> <p>1 Electric heat: Use this setting if you have an electric heating system (thermostat controls fan operation).</p>
0190 Heat Pump Changeover Valve (for heat pumps only)	<p>0 Cooling changeover valve: Use this setting if you connected a wire labeled "O" to the O/B terminal.</p> <p>1 Heating changeover valve: Use this setting if you connected a wire labeled "B" to the O/B terminal.</p>
0240 Heating Cycle Rate	<p>5 Gas or oil furnace: Standard gas/oil furnace (less than 90% efficiency).</p> <p>9 Electric furnace: Electric heating systems.</p>
0250 Heating Cycle Rate Stage 2	<p>3 Hot water or high-efficiency furnace: Hot water system or gas furnace (more than 90% efficiency).</p> <p>1 Gas/oil steam or gravity system: Steam or gravity heat systems.</p>

System setup

What other functions can I change? (See page 51 for instructions.)

Function	Settings & Options
0280 Backlight	0 Backlight off, then on for approximately 8 seconds after keypress. 1 Backlight always on low intensity, full bright after keypress.
0300 Manual/Auto Changeover See page 50 for more information.	0 Manual changeover (Heat/Cool/Off). 1 Automatic changeover (Heat/Cool/Auto/Off). Automatically turns on Heat or Cool based on room temperature. Note: System maintains minimum 3°F difference between heat and cool settings.
0320 Temperature Format (°F/°C)	0 Fahrenheit 1 Celsius
0330 Automatic Daylight Saving Time Adjustment	0 Off 1 On

System setup

What other functions can I change? (See page 51 for instructions.)

Function	Settings & Options
0500 Filter Change Reminder The reminder appears after selected number of days <i>run time</i> not actual time.	0 Off (no reminder) 1 Reminder after 10-day run time (about 1 calendar month) 2 Reminder after 30-day run time (about 3 calendar months) 3 Reminder after 60-day run time (about 6 calendar months) 4 Reminder after 90-day run time (about 9 calendar months) 5 Reminder after 120-day run time (about 1 calendar year) 6 Reminder after 180-day run time (about 18 calendar months) 7 Reminder after 270-day run time (about 2 calendar years) 8 Reminder after 365-day run time (about 3 calendar years)
0530 Smart Response Technology See page 48 for more information.	1 On 0 Off
0640 Clock Format	12 12-hour clock (i.e., “3:30 pm”) 24 24-hour clock (i.e., “15:30”)

System setup

How do I change my Wi-Fi settings? (See page 51 for instructions.)

Function	Settings & Options
0710 Restore Original Settings	0 No 1 Disconnects thermostat from Wi-Fi and restores original settings (erases customizations).
0890 Wi-Fi On/Off	1 Wi-Fi is on and can be connected to a Wi-Fi network. 0 Wi-Fi is off. Thermostat cannot be connected to a Wi-Fi network. If you are not connecting the thermostat to a Wi-Fi network this will remove the text “Wi-Fi Setup” from the messaging center.
0900 Wi-Fi Connection	1 Connected to Wi-Fi network. This is set automatically when the thermostat is connected to the Wi-Fi network. 0 Set to 0 to disconnect from the Wi-Fi network.

Frequently asked questions

Q: Will my thermostat still work if I lose my Wi-Fi connection?

A: Yes, the thermostat will operate your heating and/or cooling system with or without Wi-Fi.

Q: How do I find the password to my router?

A: Contact the manufacturer of the router or check the router documentation.

Q: Why am I not seeing my Wi-Fi setup page?

A: You are probably connected only to your router, not to your thermostat. Try connecting to the thermostat again.

Q: Why isn't my thermostat connecting to my Wi-Fi router even though it is very close to the thermostat?

A: Verify that the password entered for the Wi-Fi router is correct.

Frequently asked questions

Q: Where can I find my MAC ID and MAC CRC codes?

A: The MAC ID and MAC CRC will show in the message center of the thermostat. The numbers are also included on a card packed with the thermostat or on the back of the thermostat (visible when removed from wallplate). Each thermostat has a unique MAC ID and MAC CRC.

Q: My thermostat is unable to register to the Total Connect Comfort website.

A: Verify that the thermostat is correctly enrolled on your homeWi-Fi network. The message center will display “CONNECTION SUCCESSFUL” or “REGISTER AT TOTAL CONNECT.” You might also see the Wi-Fi Signal strength icon. Verify that the Wi-Fi router has a good internet connection. On your computer, verify that you can open the site at mytotalconnectcomfort.com If you cannot open the site, switch off the internet modem for a few seconds, then power it back on.

Frequently asked questions

Q: I registered on the Total Connect Comfort website but was unable to login using my new account.

A: Check your email and ensure that you received an activation email. Follow the instructions to activate your account and then login to the website.

Q: I have signed up on Total Connect Comfort website and have not received a confirmation email.

A: Check for the email in your Junk or Deleted folder.

Q: Is there a way to extend the signal strength?

A: Most standard routers can be set up to be a repeater. You can also purchase and install a Wi-Fi repeater.

For more FAQs, see wifithermostat.com

Troubleshooting

If you have difficulty with your thermostat, please try the following suggestions. Most problems can be corrected quickly and easily.

Display is blank

- Check circuit breaker and reset if necessary.
- Make sure power switch at heating and cooling system is on.
- Make sure furnace door is closed securely.
- Make sure C wire is connected (see page 15).

Cannot change system setting to Cool

- Check Function 0170: System Type to make sure it is set to match your heating and cooling equipment (see page 54).

Fan does not turn on when heat is required

- Check Function 0180: Heating Fan Control to make sure it is set to match your heating equipment (see page 55).

“Wait” appears on the screen

- Compressor protection feature is engaged. Wait 5 minutes for the system to restart safely, without damage to the compressor.

Troubleshooting

Heat pump issues cool air in heat mode, or warm air in cool mode

- Check Function 0190: Heat Pump Changeover Valve to make sure it is properly configured for your system (see page 55).

Button on lower right of screen is blank

- This button will remain blank unless the furnace filter change reminder is activated (see page 44).

Red light is on

- If thermostat is in Emergency Heat mode the red light is normal. It shows that the thermostat is in emergency heat mode.
- If thermostat is not in Emergency Heat mode, contact a qualified service contractor for repair.

Troubleshooting

Heating or cooling system does not respond

- Press **SYSTEM** to set system to Heat. Make sure the temperature is set higher than the Inside temperature.
- Press **SYSTEM** to set system to Cool. Make sure the temperature is set lower than the Inside temperature.
- Check circuit breaker and reset if necessary.
- Make sure power switch at heating & cooling system is on.
- Make sure furnace door is closed securely.
- If “Wait” is displayed, the compressor protection timer is on. Wait 5 minutes for the system to restart safely, without damaging the compressor (see page 48).

Heating system is running in cool mode

- Check Function 0170: System Type to make sure it is set to match your heating and cooling equipment (see page 54).

Glossary

C wire

The “C” or common wire brings 24 VAC power to the thermostat from the heating/cooling system. Some older mechanical or battery operated thermostats may not have this wire connection. It is necessary for establishing a Wi-Fi connection to your home network.

Heat Pump heating/cooling system

Heat pumps are used to heat and cool a home. If your old thermostat has a setting for auxiliary or emergency heat, you likely have a heat pump.

Conventional heating/cooling system

Non-heat pump type systems; these include air handlers, furnaces or boilers that run on natural gas, oil or electricity. They may or may not include an air conditioner.

Jumper

A small piece of wire that connects two terminals together.

MAC ID, MAC CRC

Alphanumeric codes that uniquely identify your thermostat.

QR Code®

Quick response code. A two-dimensional, machine-readable image. Your wireless device can read the black and white pattern in the square and link its browser directly to a web site. QR Code is a registered trademark of DENSO WAVE INCORPORATED.

Regulatory information

FCC Compliance Statement (Part 15.19) (USA only)

This device complies with Part 15 of the FCC Rules.

Operation is subject to the following two conditions:

- 1 This device may not cause harmful interference, and
- 2 This device must accept any interference received, including interference that may cause undesired operation.

FCC Warning (Part 15.21) (USA only)

Changes or modifications not expressly approved by the party responsible for compliance could void the user's authority to operate the equipment.

FCC Interference Statement (Part 15.105 (b)) (USA only)

This equipment has been tested and found to comply with the limits for a Class B digital device, pursuant to Part 15 of the FCC Rules. These limits are designed to provide reasonable protection against harmful interference in a residential installation. This equipment generates uses and can radiate radio frequency energy and, if not installed and used in accordance with the

instructions, may cause harmful interference to radio communications. However, there is no guarantee that interference will not occur in a particular installation. If this equipment does cause harmful interference to radio or television reception, which can be determined by turning the equipment off and on, the user is encouraged to try to correct the interference by one of the following measures:

- Reorient or relocate the receiving antenna.
- Increase the separation between the equipment and receiver.
- Connect the equipment into an outlet on a circuit different from that to which the receiver is connected.
- Consult the dealer or an experienced radio/TV technician for help.

Regulatory information

Thermostats

To comply with FCC and Industry Canada RF exposure limits for general population/ uncontrolled exposure, the antenna(s) used for these transmitters must be installed to provide a separation distance of at least 20 cm from all persons and must not be co-located or operating in conjunction with any other antenna or transmitter.

Section 7.1.2 of RSS-GEN

Under Industry Canada regulations, this radio transmitter may only operate using an antenna of type and maximum (or lesser) gain approved for the transmitter by Industry Canada. To reduce potential radio interference to other users, the antenna type and its gain should be so chosen that the equivalent isotropically radiated power (e.i.r.p.) is not more than that necessary for successful communication.

Section 7.1.3 of RSS-GEN

Operation is subject to the following two conditions:

- 1 this device may not cause interference, and
- 2 this device must accept any interference, including interference that may cause undesired operation of the device.

1-year limited warranty

Honeywell warrants this product, excluding battery, to be free from defects in the workmanship or materials, under normal use and service, for a period of one (1) year from the date of purchase by the consumer. If at any time during the warranty period the product is determined to be defective or malfunctions, Honeywell shall repair or replace it (at Honeywell's option).

If the product is defective,

- (i) return it, with a bill of sale or other dated proof of purchase, to the place from which you purchased it; or
- (ii) call Honeywell Customer Care at 1-855-733-5465. Customer Care will make the determination whether the product should be returned to the following address: Honeywell Return Goods, Dock 4 MN10-3860, 1885 Douglas Dr. N., Golden Valley, MN 55422, or whether a replacement product can be sent to you.

This warranty does not cover removal or reinstallation costs. This warranty shall not apply if it is shown by Honeywell that the defect or malfunction was caused by damage which occurred while the product was in the possession of a consumer.

Honeywell's sole responsibility shall be to repair or replace the product within the terms stated above. HONEYWELL SHALL NOT BE LIABLE FOR ANY LOSS OR DAMAGE OF ANY KIND, INCLUDING ANY INCIDENTAL OR CONSEQUENTIAL DAMAGES RESULTING, DIRECTLY OR INDIRECTLY, FROM ANY BREACH OF ANY WARRANTY, EXPRESS OR IMPLIED, OR ANY OTHER FAILURE OF THIS PRODUCT. Some states do not allow the exclusion or limitation of incidental or consequential damages, so this limitation may not apply to you.

THIS WARRANTY IS THE ONLY EXPRESS WARRANTY HONEYWELL MAKES ON THIS PRODUCT. THE DURATION OF ANY IMPLIED WARRANTIES, INCLUDING THE WARRANTIES OF MERCHANTABILITY AND FITNESS FOR A PARTICULAR PURPOSE, IS HEREBY LIMITED TO THE ONE-YEAR DURATION OF THIS WARRANTY. Some states do not allow limitations on how long an implied warranty lasts, so the above limitation may not apply to you.

This warranty gives you specific legal rights, and you may have other rights which vary from state to state.

If you have any questions concerning this warranty, please write Honeywell Customer Relations, 1985 Douglas Dr, Golden Valley, MN 55422 or call 1-855-733-5465. In Canada, write Retail Products ON15-02H, Honeywell Limited/Honeywell Limitée, 35 Dynamic Drive, Toronto, Ontario M1V4Z9.

