

MOUNTING AND INSTALLING

Use this chapter to learn how to mount the VM3A.

About Mounting the VM3A



Warning: The correct dock must be selected for the installation:

- For a vehicle installation with 10-60 VDC direct connection: Use either a VM1D standard dock or a VM3D enhanced dock.
- For a vehicle installation with 60-144 VDC connection: Use a DC/DC power supply with either a VM1D standard dock or a VM3D enhanced dock.
- To replace a Thor VX8 or Thor VX9 on a vehicle: Use the existing power supply, if applicable, and the existing power cable with either a VM1D standard dock or VM3D enhanced dock.
- To replace a VX6, VX7: Use the appropriate adapter power cable and either a VM1D standard dock or a VM3D enhanced dock. Voltage must be 10-60 VDC.
- For an AC powered application: Use an AC/DC power supply and the VMXD off-vehicle enhanced dock.

The VM3A is designed to be mounted to a dock in a vehicle with either a RAM mount or U Bracket system. A power cable is provided with some dock models. An integrated scanner mount is also offered. Optional communication cables are available.

Vehicle mounting brackets are specifically designed for vehicle mount applications. The vehicle mounted assembly restrains the VM3A and isolates it from shock and vibration. A RAM metal table stand is also available to secure the computer and dock when in an office environment.

The vehicle mount holds the dock and the VM3A attaches to the dock. The dock remains attached to the vehicle, however, the computer has a quick release located on the lower rear side that allows the computer to easily be removed from the dock. The computer can be operated for approximately 30 minutes from an internal UPS

battery when not attached to a dock. The computer can be transferred from one dock equipped vehicle to another for easy portability. The dock provides accessory attachment and conditioned power for the computer.

Overhead, dash, and roof support pillar mounting is via a RAM Mount or U-bracket accessory which includes most of the hardware required for vehicle mounting.



Warning: Never put the computer into the vehicle mounted assembly until the assembly is securely fastened to the vehicle.

Select Mounting Location

The VM3A should be secured to an area in the vehicle where it:

- Does not obstruct the driver's vision or safe vehicle operation.
- Will be protected from rain or inclement weather.
- Will be protected from extremely high concentrations of dust or wind-blown debris.
- Can be easily accessed by a user seated in the driver's seat while the vehicle is not in operation.

General Mounting Outline

The following list outlines, in a general way, the process to follow when mounting the VM3A in a vehicle.

1. [Install RAM Mount](#) or [Install U Bracket Mount or Adapter](#) to the vehicle
2. [Place Thor VM3A in the Dock.](#)
3. Secure accessories, such as, a scanner holder, to either and integrated or remote mounting bracket.
4. Adjust the computer to the best viewing angle.
5. [Mount the 802.11 Remote Antenna](#), if necessary.
6. Connect power for any peripherals.
7. Connect vehicle power:
 - [12-48 VDC Vehicles \(10-60 VDC Direct Connection\)](#)
 - [60-144 VDC Vehicles \(50-150 VDC Power Supply, Screws on Top of Lid\)](#)
 - [60-144 VDC Vehicles \(50-150 VDC Power Supply, Screws on Side of Lid\)](#)
 - [Thor VX8/Thor VX9 Adapter Cable](#)
 - [VX5/VX6/VX7 Adapter Cable](#)
8. Secure all cables in [Strain Relief Cable Clamps](#).

The VM3A is ready for use.

Install RAM Mount



Caution: This device is intended to transmit RF energy. For protection against RF exposure to humans and in accordance with FCC rules and Industry Canada rules, this transmitter should be installed such that a minimum separation distance of at least 20 cm (7.8 in.) is maintained between the antenna and the general population. This device is not to be co-located with other transmitters.

Step 1. Before installation begins, verify you have the applicable vehicle mounting assembly components necessary. Refer to the Thor VM Series Vehicle Mount Computer Accessory Guide for information on RAM mount kits and components on www.honeywellaidc.com. Kits do not include the hardware required to mount the base to the vehicle since requirements vary from vehicle to vehicle.

Step 2. You will need the following tools for mounting the RAM:

- Sockets
- Ratchet wrench
- Screwdriver
- Drill and bits, if using a round or place base
- Torque wrench capable of torquing to 20 inch pounds (1.10 N/m).

For these nuts...	Torque to
10-32 lock nuts	17-20in/lb (0-95 - 1.10 N/m)

Note: Tools are not supplied by Honeywell.

Step 3. Attach the base to the vehicle.

RAM Ball Mount

1. Determine the position for mounting the RAM ball base. Be sure to position the RAM bracket to allow access to the switches and ports on the bottom of the computer.

Note: Mount to the most rigid surface available.

2. Drill and tap holes for three 1/4 bolts. (Drawing not to scale.)

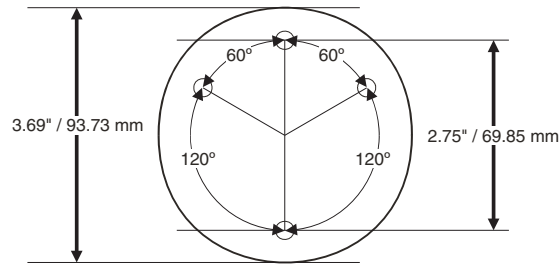

3. Attach the RAM ball base to the vehicle mounting surface using three or four 1/4 bolts (not included) or equivalent fasteners. If the mounting kit includes cone washers, use those as illustrated below.

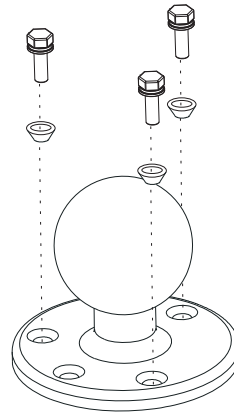

RAM Clamp Mount

1. Determine the position for mounting the RAM clamp mount. The clamp mount can be used on a beam (such as on a fork lift truck) up to 2.5" (63.5 mm) wide and approximately 2" (50.8 mm) thick. The clamp may be attached to a thicker beam by substituting longer bolts (not included). Be sure to position the RAM clamp mount to allow access to the switches and ports on the bottom of the computer. (Drawing not to scale.)

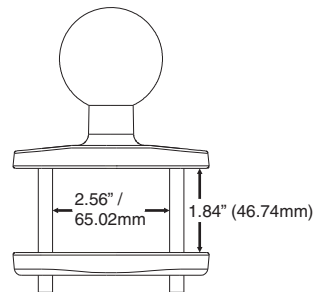

2. Position the upper clamp piece with ball on the beam. Place the bolts through the holes in the upper clamp piece. Position the lower clamp piece below the beam. Align the bolts with the holes in the lower clamp piece. Place the nylon locking nuts on the bolts and tighten the bolts.

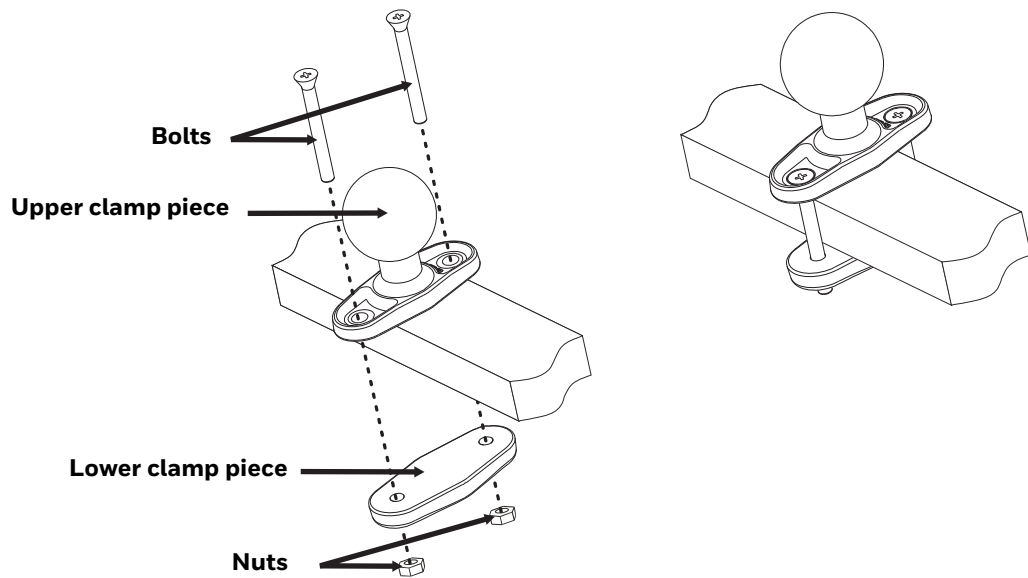

RAM Plate Mount with RAM Ball

1. Determine the position for mounting the RAM ball plate. Be sure to position the RAM plate to allow access to the switches and ports on the bottom of the computer.

Note: Mount to the most rigid surface available.

2. Attach the RAM ball plate to the vehicle mounting surface using four 1/4 bolts (not included) or equivalent fasteners. (Drawing not to scale.)

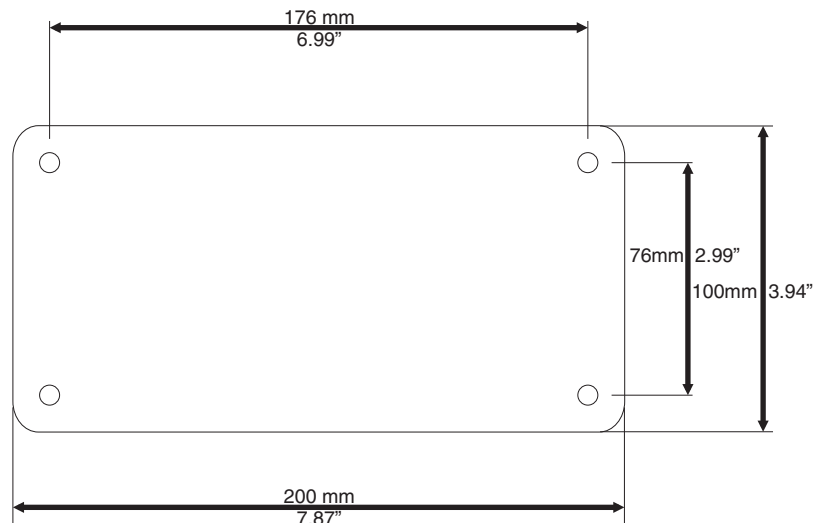

3. If not already attached, attach the RAM ball to the RAM ball plate using three M6 nuts and washers.

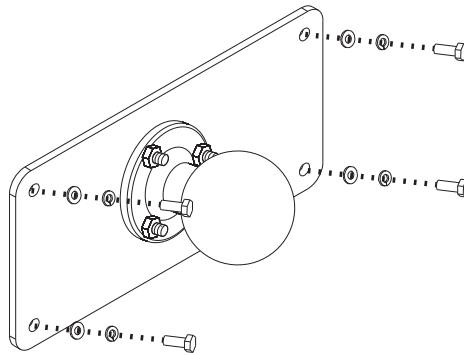

Attach RAM Mount Ball to the Dock

1. Turn the computer off before attaching the RAM mount ball.
2. Place the computer face down on a stable surface.
3. Position the RAM ball on the rear of the dock, aligning the holes on the back of the dock with the holes on the RAM ball base. Attach with four M5 screws, flat washers and lock washers.

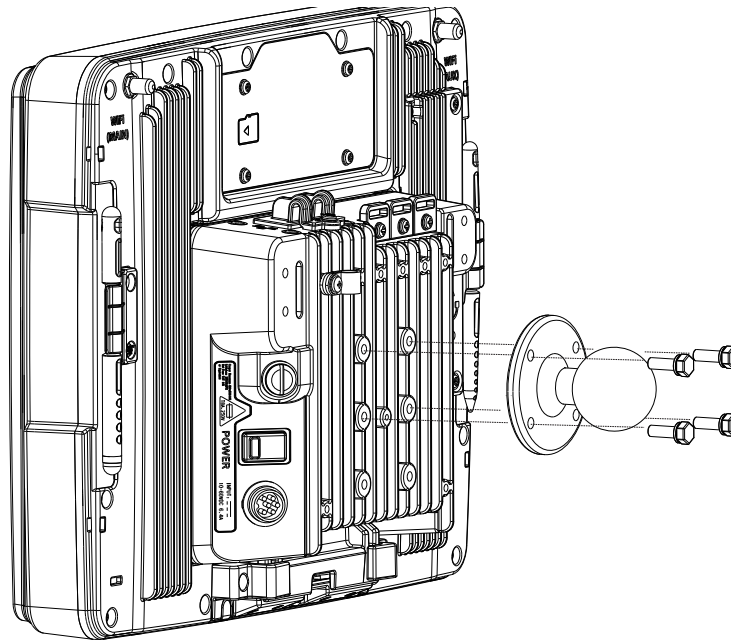

Attach Thor VM3A Assembly to RAM Mount

1. Slip the Size D RAM arm over the ball on the vehicle RAM mount (RAM Ball mount shown).
2. Insert the ball on the dock into the RAM arm and tighten the knob on the RAM arm.

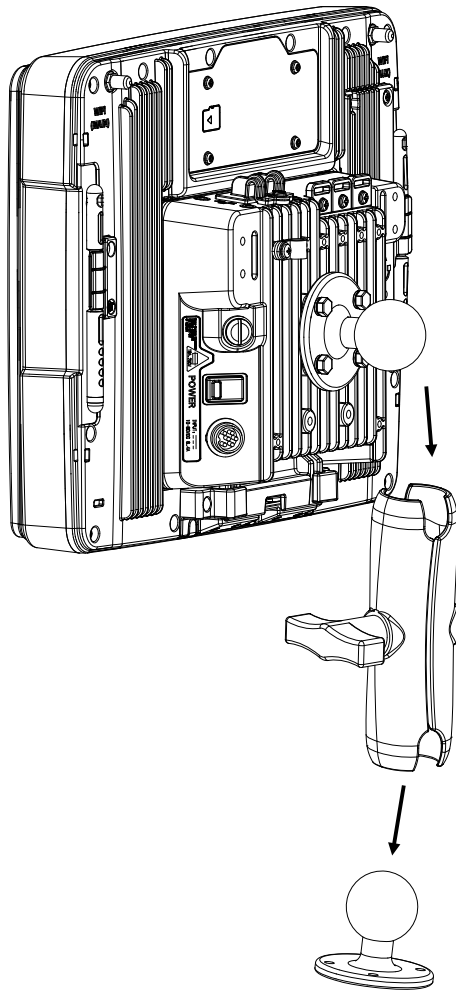

Step 3. Place the computer onto the dock.

Step 4. Attach the optional scanner holder to the Enhanced Dock.

1. Attach the accessory RAM ball to Enhanced Dock. There are two mounting provisions, one on either side of the Enhanced dock and either can be used to mount the scanner holder. (Some components omitted for detail clarity.)

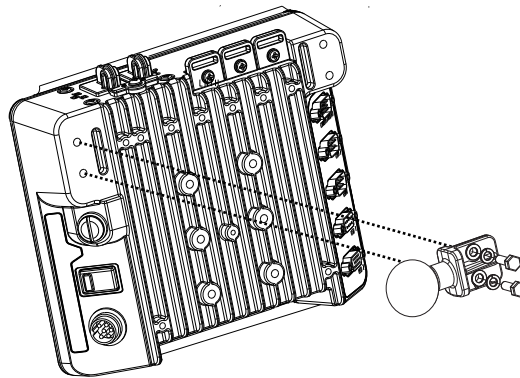

2. Attach the RAM ball to the back of the scanner holder.

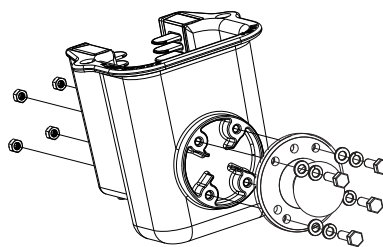

3. Slip the RAM arm over the accessory RAM ball.
4. Slip the RAM ball on the scanner holder into the RAM arm.

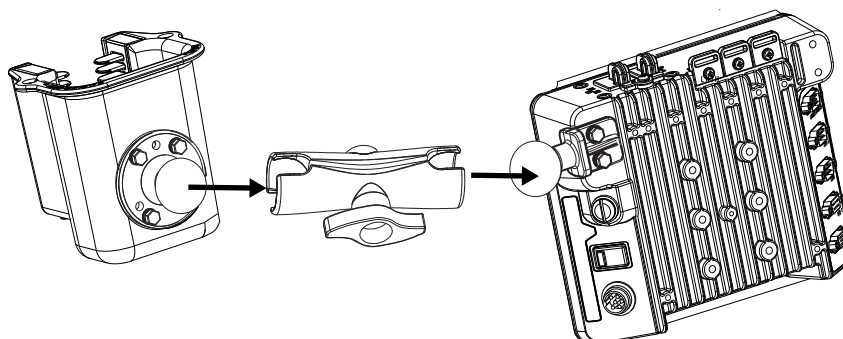

5. Tighten the knob on the RAM arm while adjusting to the desired angle.

Install U Bracket Mount or Adapter

Note: This mounting system does not have a provision for an integrated scanner holder. This accessory can be mounted separately, if desired. Contact [Technical Assistance](#) for details.



Caution: This device is intended to transmit RF energy. For protection against RF exposure to humans and in accordance with FCC rules and Industry Canada rules, this transmitter should be installed such that a minimum separation distance of at least 20 cm (7.8 in.) is maintained between the antenna and the general population. This device is not to be co-located with other transmitters.

- Step 1. Before installation begins, verify you have the applicable vehicle mounting assembly components necessary.

Mount Kit	Components
Adapter Bracket with U Bracket (For new installations only) (VM1010BRKTKIT)	<ul style="list-style-type: none"> • U Bracket • Adapter Bracket • Hardware: screws, flat washers, and lock washers
Adapter Bracket without U Bracket (VM1010BRACKET)	<ul style="list-style-type: none"> • Adapter Bracket • Hardware: screws, flat washers, and lock washers

Note: Individual RAM mounting components are also available.

Step 2. You will need the following tools for mounting the RAM:

- Sockets
- Torque wrench capable of torquing to 50 inch pounds (5.64±.56 N/m).

For these bolts...	Torque to
1/4-20x5/8 Bolts	50 in/lb (5.6 N/m)
M5x16mm Bolts	35 in/lb (4.0 N/m)
1/4 Bolts (user supplied)	50.0±5 in/lb (5.64±.56 N/m)

Note: Torque tool is not supplied by Honeywell.

Step 3. Determine the mounting position.

- The adapter bracket can be mounted in a high or low position, depending on viewing position, as shown below.

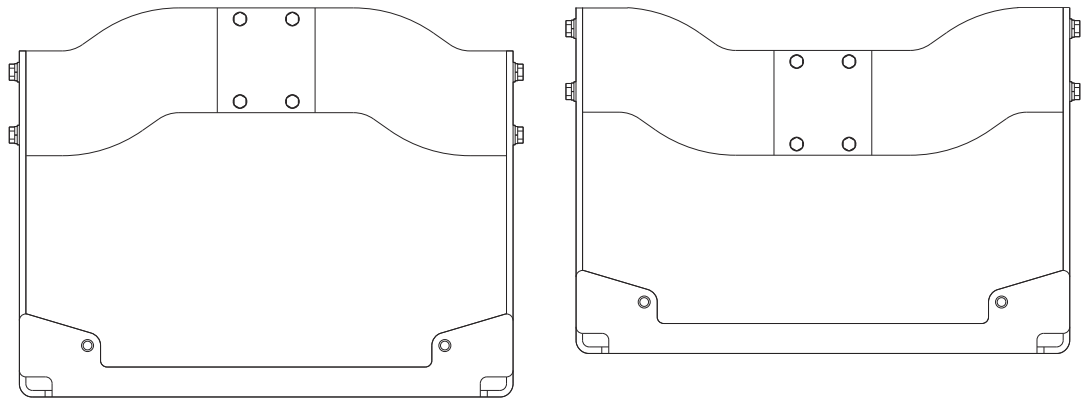

- Additionally, the slotted U bracket allows the computer to be mounted vertically or tilted forward or backward for best viewing angle.

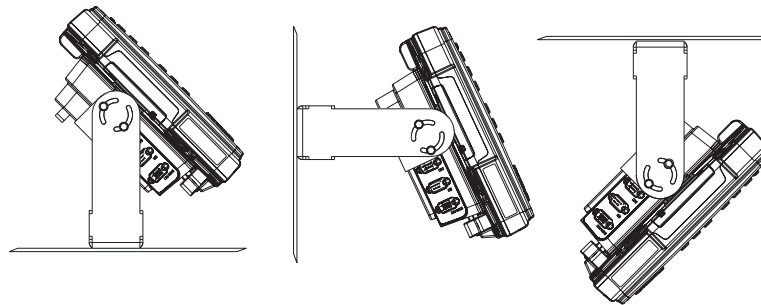

Step 4. Install U Bracket to Vehicle

1. Position the bracket to allow access to the switches and ports on the bottom of the computer. Skip this step if installing a U Bracket mount adapter bracket.

- Attach the bottom mounting bracket to the vehicle mounting surface using a minimum of four 1/4 bolts (or equivalent) fasteners. (Drawing no to scale.)

Note: 1/4 bolts and washers not included and vary per vehicle type. It is recommended to use lock washers and flat washers on the fasteners.

Note: Mount to the most rigid surface available.

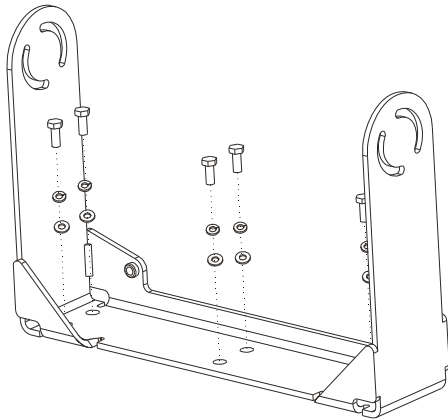
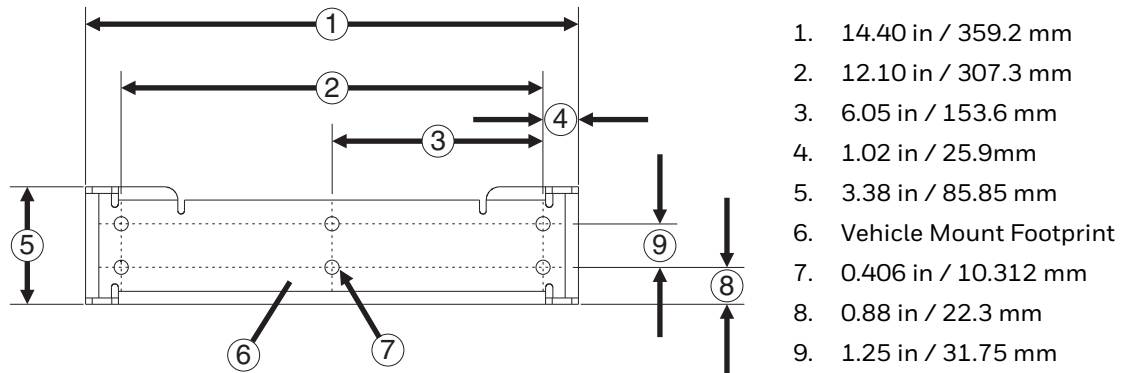

Step 5. If the dock has a RAM ball attached, the RAM ball must be removed from the dock to use the U Bracket mount. The hardware used to attach the RAM ball to the dock is not reused for the U Bracket mount.

Step 6. Attached the Adapter Bracket to dock.

- Attach the Adapter Bracket to the dock using four each M5x16mm bolt, M5 lock washer and M5 flat washer. Torque to 35 in/lbs (4.0 N/m).

Note: For the steps below, always place the lock washer on the bolt before the flat washer.

- Attach the Adapter Bracket assembly to the U Bracket using 4 each 1/4- 20x5/8 bolt, 1/4 lock washer and 1/4 flat washer.

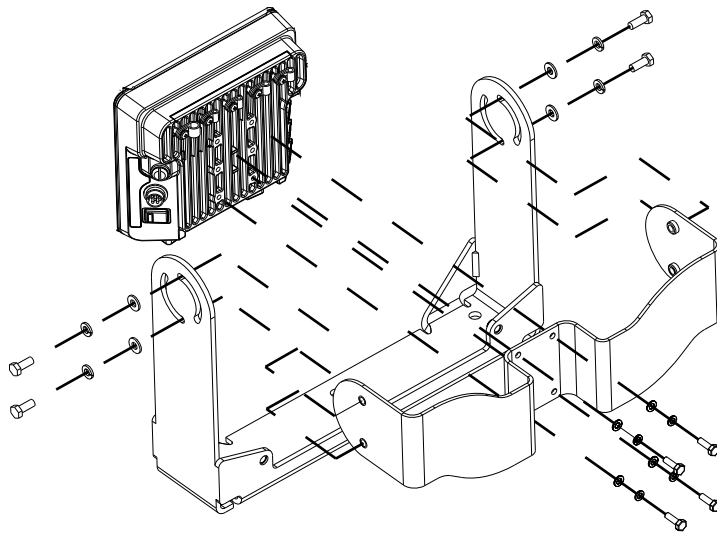

3. If the computer is not already mounted to the dock, [Place Thor VM3A in the Dock.](#)
4. Adjust the computer to the desired viewing angle.
5. Torque the 14-20 bolts to 50 in/lbs (5.6 N/m).

Install Table Stand

When the VM3A is used in an office environment, it can be mounted in a table stand. To use the table stand:

1. Attach the RAM ball to the RAM Metal Table Stand with the supplied bolts and nuts.
2. If not present, attach a RAM ball to the VMXD off-vehicle dock.
3. Slide the size D RAM arm over the ball on the table mount.
4. Insert the ball on the dock into the RAM arm and tighten the knob on the RAM arm.

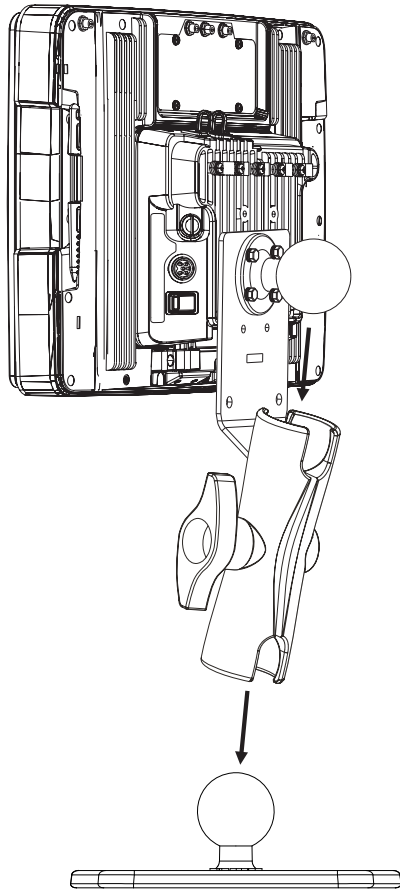

5. If the computer is not already mounted to the dock, [Place Thor VM3A in the Dock.](#)

Place Thor VM3A in the Dock

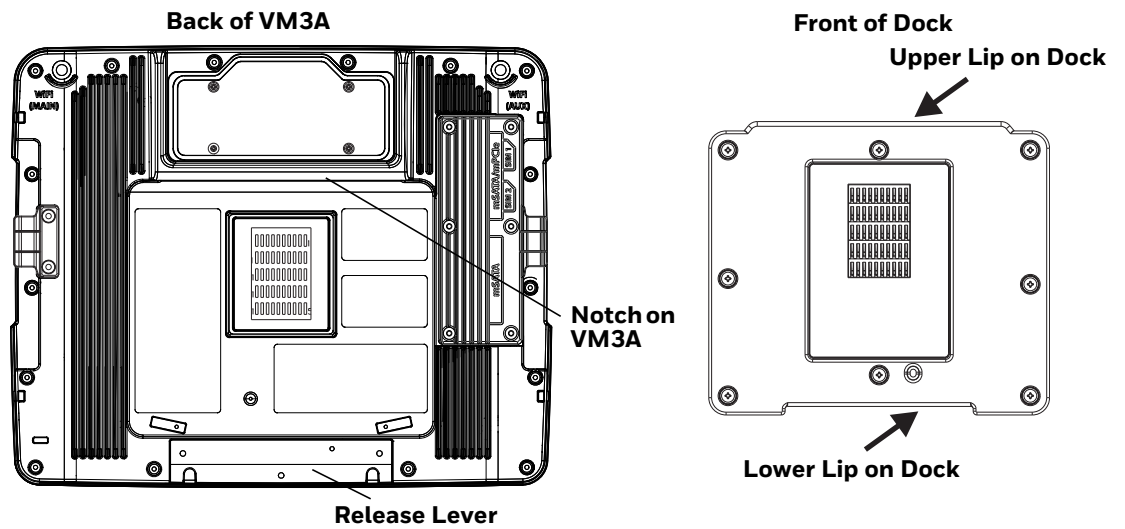

1. Locate the notch on the upper rear of the VM3A.
2. Slide this notch over the top lip of the dock. Slide the VM3A from side to side on the dock to make sure it fully engages on the lip of the dock. If the computer cannot be slid side to side, the lip is engaged.
3. Pull the quick release lever on the computer down and push the computer against the dock.
4. Release the quick release lever. The quick release lever catches the lower lip on the dock and secures the computer to the dock. Be sure the red quick release lever is pushed all the way in to secure the computer to the dock.
5. If necessary, adjust the viewing angle of the computer.

When the Thor VM3A is placed in the dock, the following may happen:

- If the computer is Off and power is connected to the dock, the computer may boot when placed in the dock. See [Auto-On](#).
- If the computer is On and power is connected to the dock, the power management timers may change when the computer is placed in the dock. See [Power Options](#).

When the Thor VM3A is removed from the dock, the following may happen:

- If the computer is On and power is connected to the dock, the power management timers may change when the computer is placed in the dock. See [Select a Power Scheme](#).

About the 802.11 Remote Antenna

Remote antennas are available for the 802.11 WLAN radio.



Caution: If the Thor VM3A is setup for use with external antennas, do not power up the computer without the external antennas connected. Damage to the WLAN radio may result. Never operate with only one external antenna connected.

The Remote Antenna Installation Kit consists of two brackets (base plate and right angle), cable, and antenna. Tools are not included.

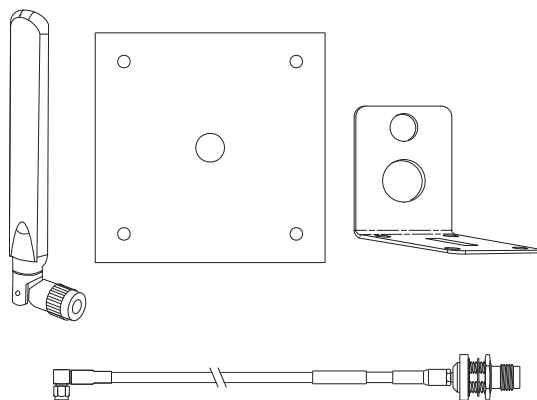

The desired remote antenna bracket is mounted on the top of a forklift, truck, or other vehicle and cabled to the computer inside the vehicle.

The Vehicle Remote Mount Antenna cannot be used by devices with internal antennas.

Mount the 802.11 Remote Antenna

Components

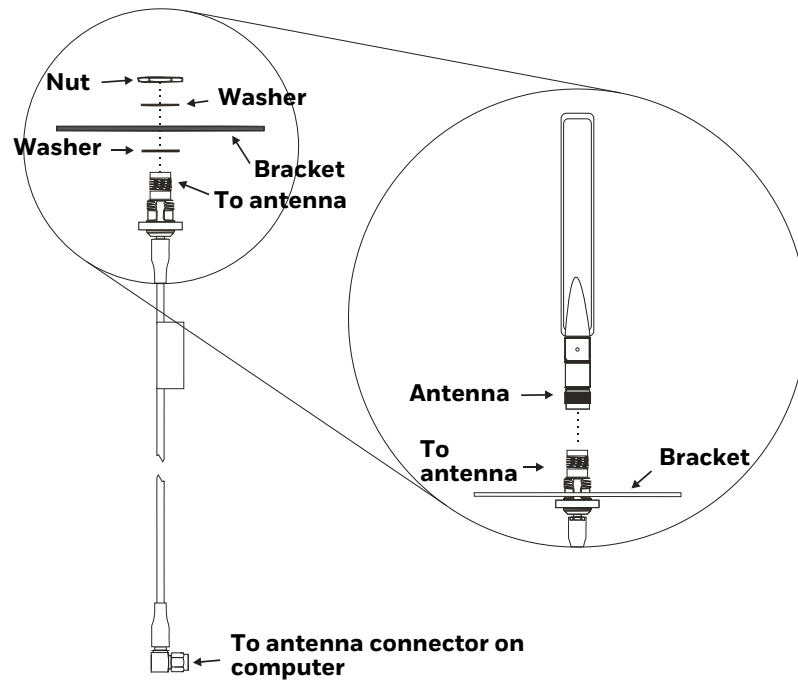

Typical Installation

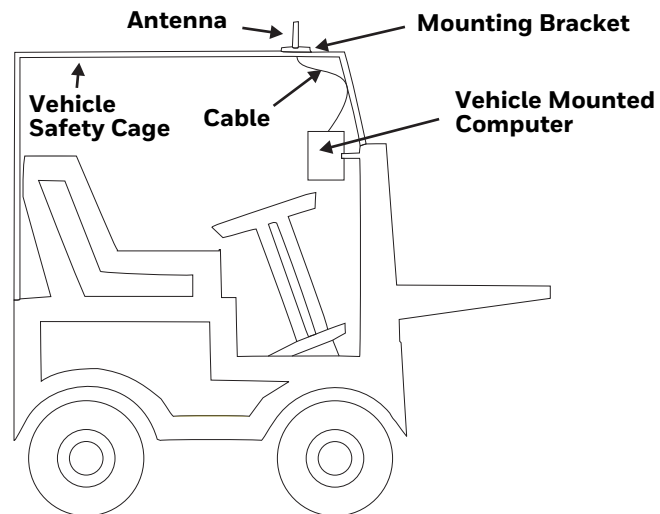

Instructions

1. Attach and secure the desired mounting bracket to the highest point on the safety cage, following these precautions:
 - The plate must be mounted so the antenna is not damaged while the vehicle or any of its parts are moving.
 - The antenna mounting portion of the bracket must be parallel to the floor.
 - If using two antennas, they should be mounted at least 12 inches (304.8mm) apart for best performance.
2. Secure the whip antenna to the mounting bracket.
3. Connect the antenna cable to the whip antenna.
4. Use cable ties to secure the coaxial cable to the vehicle as necessary. Make sure the cable is routed so it is not damaged by any moving parts of the vehicle.
5. Connect the cable to the antenna connector (Wi-Fi Main or Wi-Fi Aux) on the computer.
6. Repeat the steps above for the second 802.11 antenna.

Connect Power

See [Power Supply Connector](#) for connector pinout.

For the VM1D Standard Dock and VM3D Enhanced Dock, power options include:

- [12-48 VDC Vehicles \(10-60 VDC Direct Connection\)](#) - Direct connection to vehicle power.
- [60-144 VDC Vehicles \(50-150 VDC Power Supply, Screws on Side of Lid\)](#) - Requires the use of a DC/DC power supply.
- [60-144 VDC Vehicles \(50-150 VDC Power Supply, Screws on Top of Lid\)](#) - Requires the use of a DC/DC power supply.
- [VX5/VX6/VX7 Adapter Cable](#) - For applications where the VM3A replaces a previously installed VX6 or VX7.
- [Thor VX8/Thor VX9 Adapter Cable](#) - For applications where the Thor VM3A (with a VM1D Standard Dock or VM3D Enhanced dock (replaces a previously installed Thor VX8 or Thor VX9.
- [CV60 Adapter Cable](#) - For applications where the VM3A replaces a previously installed.
- [Screen Blanking Installation](#) - Optional connection to blank the VM3A display while the vehicle is in motion.

When using the Thor VM3A with AC power, use the VMXD Enhanced Dock for Off-Vehicle Use and:

- [External AC/DC Power Supply](#) - For use when DC power is not available to power the computer, such as in an office environment.

12-48 VDC Vehicles (10-60 VDC Direct Connection)



Caution: For installation by trained service personnel only.



Caution: These instructions for use with **VM1D Standard Dock** and **VM3D Enhanced Dock** only.

Fuse Requirements for 10-60 VDC Direct Connection



Warning: For proper and safe installation, the input power cable must be connected to a fused circuit on the vehicle. If the supply connection is made directly to the battery, the fuse should be installed in the positive lead within 5 inches of the battery's positive (+) terminal. If an unused fuse holder is not available on the vehicle, use **VM3055FUSE** (or equivalent) to install the fuse as shown below:

- For 12VDC input, use the 10A fuse from the kit or a slow blow fuse that has a DC voltage rating greater than 12VDC.
- For 24VDC input, use the 6A fuse from the kit or a slow blow fuse that has a DC voltage rating greater than 24VDC.
- For 36VDC input, use the 4A fuse from the kit or a slow blow fuse that has a DC voltage rating greater than 36VDC.
- For 48VDC input, use the 3A fuse from the kit or a slow blow fuse that has a DC voltage rating greater than 48VDC.

Note: For North America, a UL Listed fuse is to be used.

Power Cable Identification for 10-60 VDC Direct Connection

The DC power cable is included with the dock:



Caution: Twist the red and red/white wires together and twist the black and black/white wires together before connecting to vehicle power.

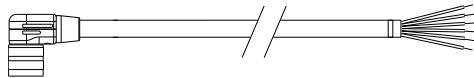

Wire Color	Connection
Red	DC + (10-60 VDC)
Red/White	DC + (10-60 VDC)
Black	DC -
Black/White	DC -
Green	Ground
Blue	Ignition Input (optional)

10-60 VDC Direct Power Connection

1. The Thor VM3A must not be mounted in the dock. The power switch on the dock must be turned Off. The power cable must be UNPLUGGED from the dock.
2. While observing the [Fuse Requirements for 10-60 VDC Direct Connection](#), connect the power cable as close as possible to the actual battery terminals of the vehicle (if using unswitched power).
3. Use proper electrical and mechanical fastening means for terminating the cable. Properly sized “crimp” type electrical terminals are an accepted method of termination. Please select electrical connectors sized for use with 20AWG (0.81mm²) conductors.
4. Refer to the wiring diagrams following this section for wire colors and connections:
 - [Ignition Control Wiring Diagram for 10-60 VDC Direct Power](#)
 - [Auto-On Control Wiring Diagram for 10-60 VDC Direct Connection](#)
 - [Manual On/Off Control Wiring Diagram for 10-60 VDC Direct Connection](#)
5. Route the power cable the shortest way possible removing any left-over cable. The cable is rated for a maximum temperature of 105°C (221°F). Therefore, when routing this cable it should be protected from physical damage and from surfaces that might exceed this temperature. Cable should be protected from physical damage from moving parts. Do not expose the cable to chemicals or oil that may cause the wiring insulation to deteriorate. Always route the cable so that it does not interfere with safe operation and maintenance of the vehicle.
6. Provide mechanical support for the cable by securing it to the vehicle structure at approximately one foot intervals, taking care not to over tighten and pinch conductors or penetrate outer cable jacket.
7. Connect the watertight connector end of the power cable to the dock power connector by aligning the connector pins to the power connector; push down on the watertight connector and twist it to fasten securely.
8. Secure the power cable to the computer using the [Strain Relief Cable Clamps](#).
9. [Place Thor VM3A in the Dock](#)
10. If using the [Screen Blanking Installation](#) feature, install the screen blanking box or switch.
11. [Power On the Computer](#).

Once installation is complete, remember to start the computer and configure the [Power Mode](#).

See the [Auto-On](#) control panel.

Ignition Control Wiring Diagram for 10-60 VDC Direct Power

Ignition wire must be connected and Ignition Control must be selected on the [Power Mode](#) control panel. When switched vehicle power is available the Thor VM3A ignition signal wire can be connected (less than 1mA over input voltage

range) to the switched circuit to allow the computer to power on when the vehicle is switched on and go into shut down (see note below) when the vehicle is switched off.

Note: When the vehicle is switched off, the Thor VM3A treats this event as a power button press. The default setting for a power button press is to power the device off, however additional options are available on the Advanced tab of the [Power Options](#) control panel.

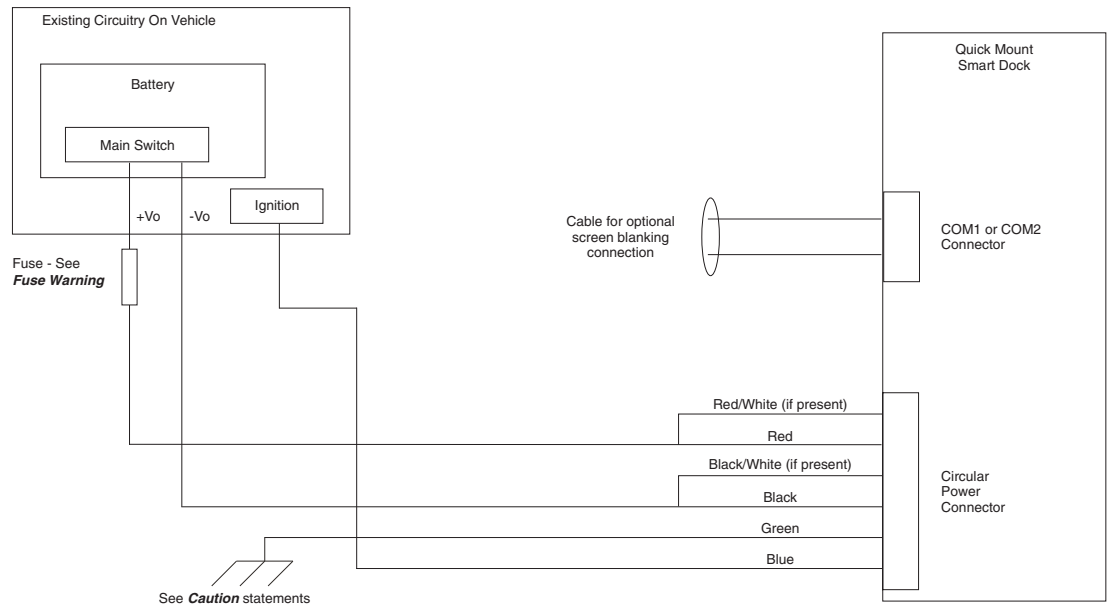

Caution: For battery powered vehicles:

- VIN+ (red wire) is connected to battery positive. If there is a red wire and a red/white wire, twist them together and connect to battery positive.
- VIN- (black wire) must be connected to battery negative. If there is a black wire and a black/white wire, twist them together and connect to battery negative.
- GND (green wire) must be connected to the vehicle chassis ground.



Caution: For internal combustion engine powered vehicles:

- VIN+ (red wire) is connected to battery positive. If there is a red wire and a red/white wire, twist them together and connect to battery positive.
- VIN- (black wire) must be connected to battery negative. If there is a black wire and a black/white wire, twist them together and connect to battery negative.
- GND (green wire) is connected to the vehicle chassis ground, which can also be battery negative.



Warning: For proper and safe installation, follow the [Fuse Requirements for 10-60 VDC Direct Connection](#).

Auto-On Control Wiring Diagram for 10-60 VDC Direct Connection

Auto-ON must be selected on the [Power Mode](#) control panel. The vehicle supply connections should be made to vehicle switched power to allow the terminal to automatically powerup when vehicle power is switched on or when the power switch on the back of the dock is placed in the On position. The Ignition wire is not used and should be left disconnected.

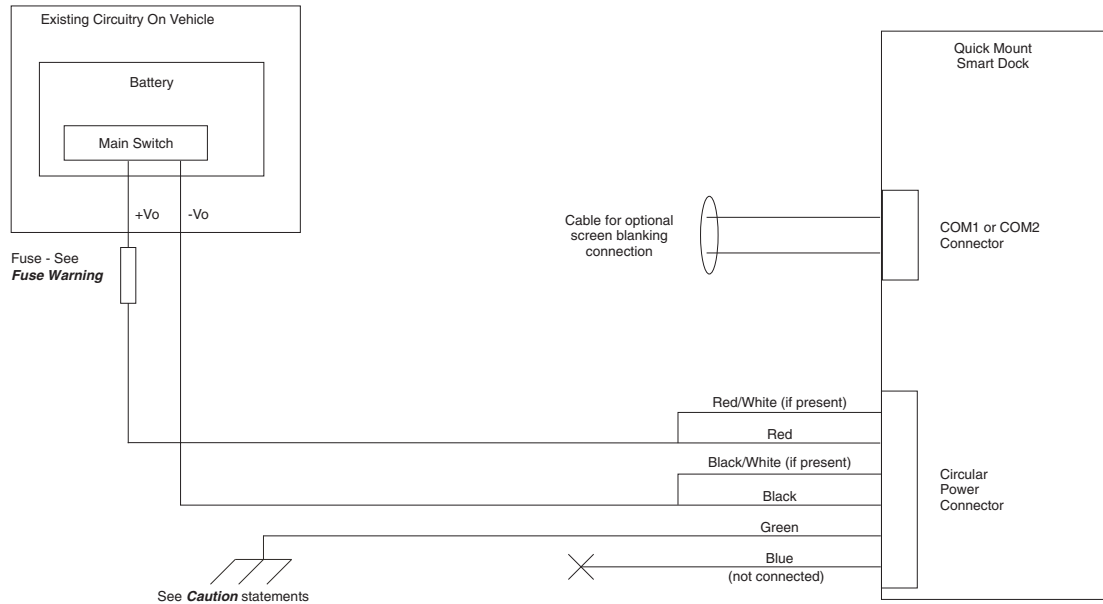

Caution: For battery powered vehicles:

- VIN+ (red wire) is connected to battery positive. If there is a red wire and a red/white wire, twist them together and connect to battery positive.
- VIN- (black wire) must be connected to battery negative. If there is a black wire and a black/white wire, twist them together and connect to battery negative.
- GND (green wire) must be connected to the vehicle chassis ground.



Caution: For internal combustion engine powered vehicles:

- VIN+ (red wire) is connected to battery positive. If there is a red wire and a red/white wire, twist them together and connect to battery positive.
- VIN- (black wire) must be connected to battery negative. If there is a black wire and a black/white wire, twist them together and connect to battery negative.
- GND (green wire) is connected to the vehicle chassis ground, which can also be battery negative.



Warning: For proper and safe installation, follow the [Fuse Requirements for 10-60 VDC Direct Connection](#).

Manual On/Off Control Wiring Diagram for 10-60 VDC Direct Connection

Ignition wire must be left unconnected. Standard must be selected from the **Power Mode** control panel.

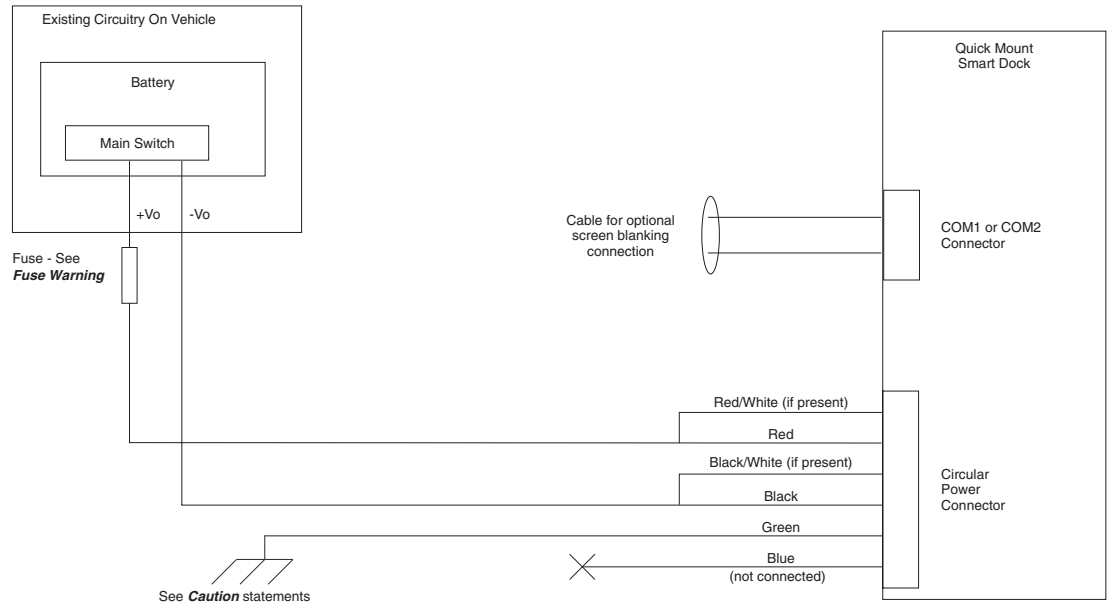

Caution: For battery powered vehicles:

- VIN+ (red wire) is connected to battery positive. If there is a red wire and a red/white wire, twist them together and connect to battery positive.
- VIN- (black wire) must be connected to battery negative. If there is a black wire and a black/white wire, twist them together and connect to battery negative.
- GND (green wire) must be connected to the vehicle chassis ground.



Caution: For internal combustion engine powered vehicles:

- VIN+ (red wire) is connected to battery positive. If there is a red wire and a red/white wire, twist them together and connect to battery positive.
- VIN- (black wire) must be connected to battery negative. If there is a black wire and a black/white wire, twist them together and connect to battery negative.
- GND (green wire) is connected to the vehicle chassis ground, which can also be battery negative.



Warning: For proper and safe installation, follow the **Fuse Requirements for 10-60 VDC Direct Connection**.

60-144 VDC Vehicles (50-150 VDC Power Supply, Screws on Side of Lid)



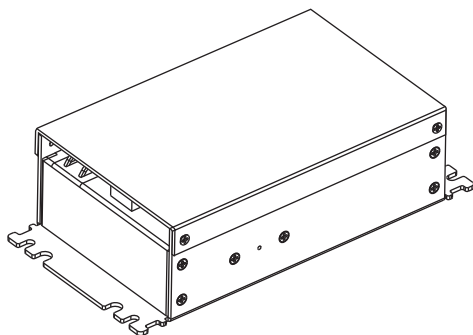

Caution: These instructions are for use with the **VM1D Standard Dock** and **VM3D Enhanced Dock** only.

This option requires DC/DC external power supply Honeywell Part no. 9000313PWRSPLY.

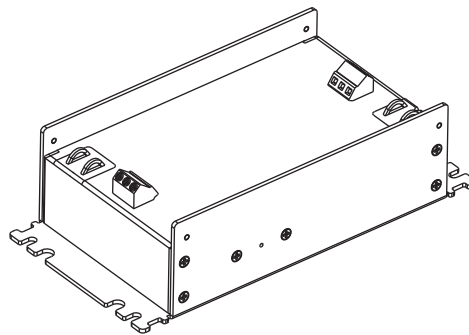

Shown with Lid Attached
Lid is secured with screws on the side of lid.



Shown with Lid Removed
Input and output connector blocks under lid.
One positive (VIN+), negative (VIN-), and ground () connection in input block.
One positive (Vo+) and negative (Vo-) connection in output block.

If the DC/DC power supply does not have screws in the side of the lid, see [60-144 VDC Vehicles \(50-150 VDC Power Supply, Screws on Top of Lid\)](#).



Caution: For installation by trained service personnel only.



Caution: Usage in areas where moisture can affect the power supply connections should be avoided. The power supply should be mounted in a dry location within the vehicle or placed in a suitable protective enclosure.



Caution: Use caution when routing the power cable. See [12-48 VDC Vehicles \(10-60 VDC Direct Connection\)](#).

Fuse Requirements 50-150VDC Power Supply, Screws on Side of Lid



Warning: For proper and safe installation, the input power cable must be connected to a fused circuit on the vehicle. If the supply connection is made directly to the battery, the fuse should be installed in the positive lead within 5 inches of the battery's positive (+) terminal. Use VM3055FUSE (or equivalent) to install the fuse as shown below:

For all voltages, use the 3A fuse from the kit or a slow blow fuse that has a DC voltage rating greater than the vehicle input voltage.

Note: For North America, a UL Listed fuse is to be used.

Power Cable Identification for 50-150VDC Power Supply, Screws on Side of Lid

The DC power cable is included with the dock:



Caution: Twist the red and red/white wires together and twist the black and black/white wires together before connecting to vehicle power.

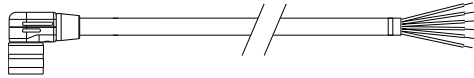

Wire Color	Connection
Red	DC + (10-60 VDC)
Red/White	DC + (10-60 VDC)
Black	DC -
Black/White	DC -
Green	Ground
Blue	Ignition Input (optional)

Vehicle 50-150 VDC Power Connection

1. Please review the [Wiring Diagram for 50-150 VDC Power Supply, Screws on Top of Lid](#), before beginning power cable install.
2. The computer must not be mounted in the dock. The power switch on the dock must be turned Off. The power cable must be UNPLUGGED from the dock.
3. Route the cable from the VM3A to the DC/DC power supply. Route the power cable the shortest way possible. The cable is rated for a maximum temperature of 105°C (221°F). When routing this cable, it should be protected from physical damage and from surfaces that might exceed this temperature. Do not expose the cable to chemicals or oil that may cause the wiring insulation to deteriorate. Always route the cable so that it does not interfere with safe operation and maintenance of the vehicle.
4. Cut the cable to length and strip the wire ends. Retain the portion of the cut off cable for use in the connection to the vehicle.

5. Remove the lid from the DC/DC power supply.
6. Connect the stripped end of the positive wires (red and red/white twisted together) to the output block. See [Power Cable Identification for 10-60 VDC Direct Connection](#).
7. Connect the stripped end of the negative wires (black and black/white twisted together) to the output. See [Power Cable Identification for 50-150VDC Power Supply, Screws on Side of Lid](#).

Note: The input block has VIN+, VIN- and GND terminals. The output block has VO+ and VO- terminals.

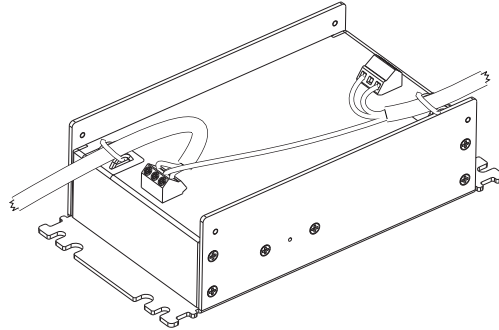

8. Use the portion of the power cable that was previously cut off to connect from the DC/DC power supply input side the vehicle electrical system. Connect the ground (green) wire from the computer to the GND terminal on the input side of the DC/DC power supply.
9. Route the wiring from the DC/DC power supply to the vehicle's electrical system. Do not connect to vehicle power at this time.
10. Strip the wire ends and connect to the input side of the DC/DC power supply.
11. Use looms and wire ties to secure all wiring as shown.
12. Reattach the cover with the screws.
13. Connect the DC/DC power supply to the vehicle's electrical system as directed below:



Caution: For battery powered vehicles only.

- VIN+ is connected to battery positive
- VIN- must be connected to battery negative
- GND must be connected to the vehicle chassis ground



Caution: For internal combustion engine power vehicles.

- VIN+ is connected to battery positive
- VIN- must be connected to battery negative

- GND is connected to the vehicle chassis ground, which can also be battery negative
14. While observing the [Fuse Requirements 50-150VDC Power Supply, Screws on Side of Lid](#) connect the power cable as close as possible to the actual battery terminals of the vehicle. When available, always connect to unswitched terminals in the vehicle fuse panel, after providing proper fusing.



Caution: For uninterrupted power, electrical supply connections should not be made at any point after the ignition switch of the vehicle.

15. Use proper electrical and mechanical fastening means for terminating the cable. Properly sized “crimp” type electrical terminals are an accepted method of termination. Select electrical connectors sized for use with 18AWG (1mm²) conductors.
16. Provide mechanical support for the cable by securing it to the vehicle structure at approximately one foot intervals, taking care not to over tighten and pinch conductors or penetrate the outer cable jacket.
17. Connect the watertight connector end of the power cable to the dock power connector by aligning the connector pins to the power connector; push down on the watertight connector and twist it to fasten securely. Flip the power switch on the back of the dock to On.
18. Secure the power cable to the computer using the [Strain Relief Cable Clamps](#).
19. [Place Thor VM3A in the Dock](#).
20. If using the [Screen Blanking Installation](#) feature, install the screen blanking box or switch.
21. [Power On the Computer](#).

Once installation is complete, remember to start the computer and configure the [Power Mode](#).

See the [Auto-On](#) control panel.

Note: *Ignition control is not available for trucks over 60VDC.*

Wiring Diagram for 50-150VDC Power Supply, Screws on Side of Lid

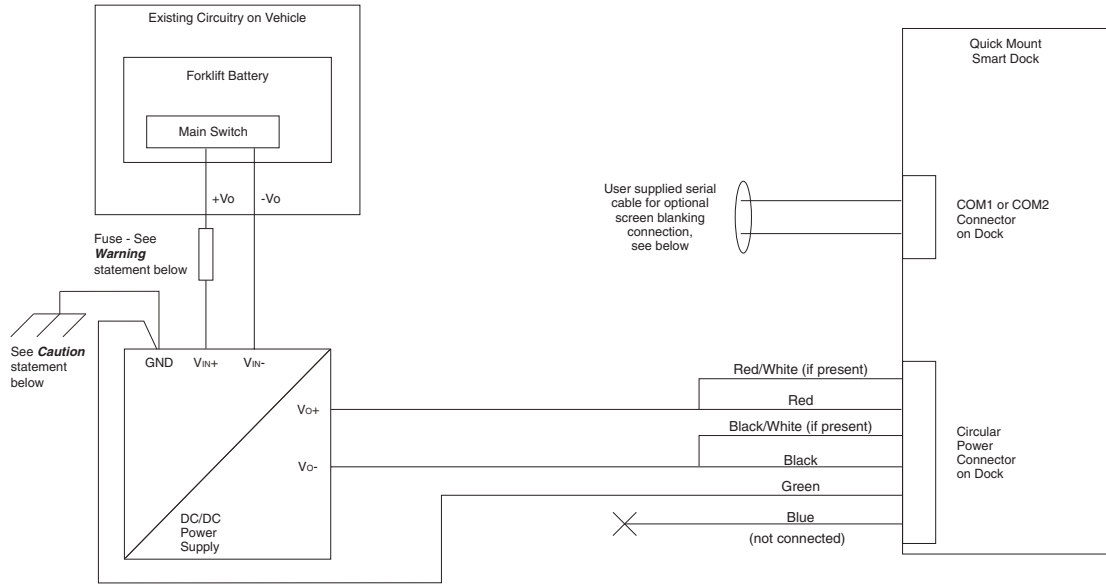

Caution: For battery powered vehicles:

- GND must be connected to the vehicle chassis ground.



Caution: For internal combustion engine powered vehicles:

- GND is connected to the vehicle chassis ground, which can also be battery negative.



Warning: For proper and safe installation, follow the [Fuse Requirements 50-150VDC Power Supply, Screws on Side of Lid](#).

60-144 VDC Vehicles (50-150 VDC Power Supply, Screws on Top of Lid)



Caution: These instructions are for use with [VM1D Standard Dock](#) and [VM3D Enhanced Dock](#) only.

This option requires DC/DC power supply Honeywell Part no. VX89303PWRSPLY shown below.

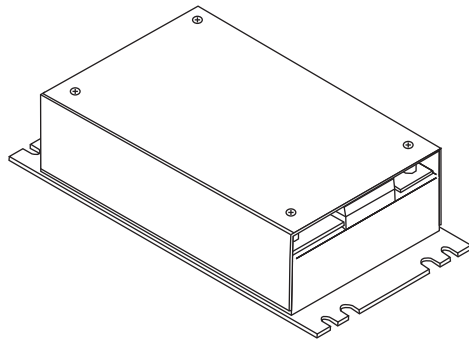

Shown with Lid Attached
Lid is secured with screws on the side of lid.

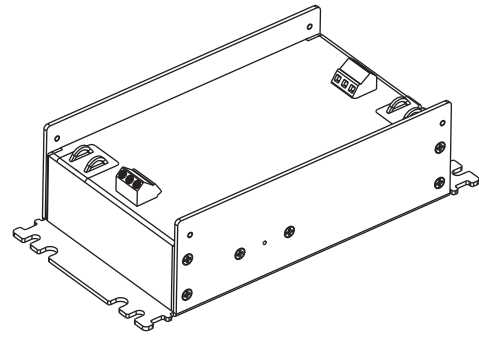

Shown with Lid Removed
Input and output connector blocks under lid.

Two positive (+), negative (-), and ground (\oplus) connection per terminal block.

If the DC/DC power supply does not have screws in the top of the lid, see [60-144 VDC Vehicles \(50-150 VDC Power Supply, Screws on Side of Lid\)](#).



Caution: For installation by trained service personnel only.



Caution: Usage in areas where moisture can affect the power supply connections should be avoided. The power supply should be mounted in a dry location within the vehicle or placed in a suitable protective enclosure.



Caution: Use caution when routing the power cable. See [12-48 VDC Vehicles \(10-60 VDC Direct Connection\)](#).

Fuse Requirements for 50-150 VDC Power Supply, Screws on Top of Lid



Warning: For proper and safe installation, the input power cable must be connected to a fused circuit on the vehicle. If the supply connection is made directly to the battery, the fuse should be installed in the positive lead within 5 inches of the battery's positive (+) terminal. Use VM3055FUSE (or equivalent) to install the fuse as shown below:

For all voltages, use the 3A fuse from the kit or a slow blow fuse that has a DC voltage rating greater than the vehicle input voltage.

Note: For North America, a UL Listed fuse is to be used.

Power Cable Identification for 50-150 VDC Power Supply, Screws on Top of Lid

The DC power cable is included with the dock:



Caution: Twist the red and red/white wires together and twist the black and black/white wires together before connecting to vehicle power.

Wire Color	Connection
Red	DC + (10-60 VDC)
Red/White	DC + (10-60 VDC)
Black	DC -
Black/White	DC -
Green	Ground
Blue	Ignition Input (optional)

Vehicle 50-150 VDC Power Connection

1. Please review the [Wiring Diagram for 50-150 VDC Power Supply, Screws on Top of Lid](#), before beginning power cable install.
2. The Thor VM3A must not be mounted in the dock. The power switch on the dock must be turned Off. The power cable must be UNPLUGGED from the dock.
3. Route the cable from the computer to the DC/DC power supply. Route the power cable the shortest way possible. The cable is rated for a maximum temperature of 105°C (221°F). When routing this cable, it should be protected from physical damage and from surfaces that might exceed this temperature. Do not expose the cable to chemicals or oil that may cause the wiring insulation to deteriorate. Always route the cable so that it does not interfere with safe operation and maintenance of the vehicle.
4. Cut the cable to length and strip the wire ends. Retain the portion that was cut off for use in connecting to the vehicle power.
5. Remove the lid from the DC/DC power supply.
6. Connect the stripped end of the positive wires (red and red/white twisted together) to the output block. See [Power Cable Identification for 50-150 VDC Power Supply, Screws on Top of Lid](#).
7. Connect the stripped end of the negative wires (black and black/white twisted together) to the output. See [Power Cable Identification for 50-150 VDC Power Supply, Screws on Top of Lid](#).

Note: The input and output blocks each have two + (positive), two – (negative) and two ⊕ (ground) connectors. Either connector in the block can be used to connect the matching polarity wire.

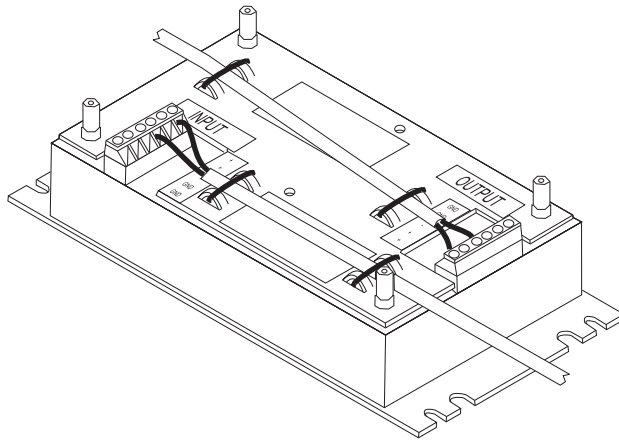

8. Route the wiring from the DC/DC power supply to the vehicle's electrical system using the portion of the power cable previously cut off. Do not connect to vehicle power at this time.
9. Strip the wire ends and connect to the input side of the DC/DC power supply.
10. Use looms and wire ties to secure all wiring as shown.
11. Reattach the cover with the screws.
12. Connect the DC/DC power supply to the vehicle's electrical system as directed below:



Caution: For battery powered vehicles:

- VIN+ is connected to battery positive
- VIN- must be connected to battery negative
- GND must be connected to the vehicle chassis ground



Caution: For internal combustion engine powered vehicles:

- VIN+ is connected to battery positive
- VIN- must be connected to battery negative
- GND must be connected to the vehicle chassis ground

13. While observing the [Fuse Requirements for 50-150 VDC Power Supply, Screws on Top of Lid](#), connect the power cable as close as possible to the actual battery terminals of the vehicle. When available, always connect to unswitched terminals in the vehicle fuse panel, after providing proper fusing.



Caution: For uninterrupted power, electrical supply connections should not be made at any point after the ignition switch of the vehicle.

14. Use proper electrical and mechanical fastening means for terminating the cable. Properly sized “crimp” type electrical terminals are an accepted method

of termination. Select electrical connectors sized for use with 18AWG (1mm²) conductors.

15. Provide mechanical support for the cable by securing it to the vehicle structure at approximately one foot intervals, taking care not to over tighten and pinch conductors or penetrate the outer cable jacket.
16. Connect the watertight connector end of the power cable to the dock power connector by aligning the connector pins to the power connector; push down on the watertight connector and twist it to fasten securely. Flip the power switch on the back of the dock to On.
17. Secure the power cable to the computer using the [Strain Relief Cable Clamps](#).
18. [Place Thor VM3A in the Dock](#).
19. If using the [Screen Blanking Installation](#) feature, install the screen blanking box or switch.
20. [Power On the Computer](#).

Once installation is complete, remember to start the computer and configure the [Power Mode](#).

See the [Auto-On](#) control panel.

Note: Ignition control is not available for trucks over 60VDC.

Wiring Diagram for 50-150 VDC Power Supply, Screws on Top of Lid

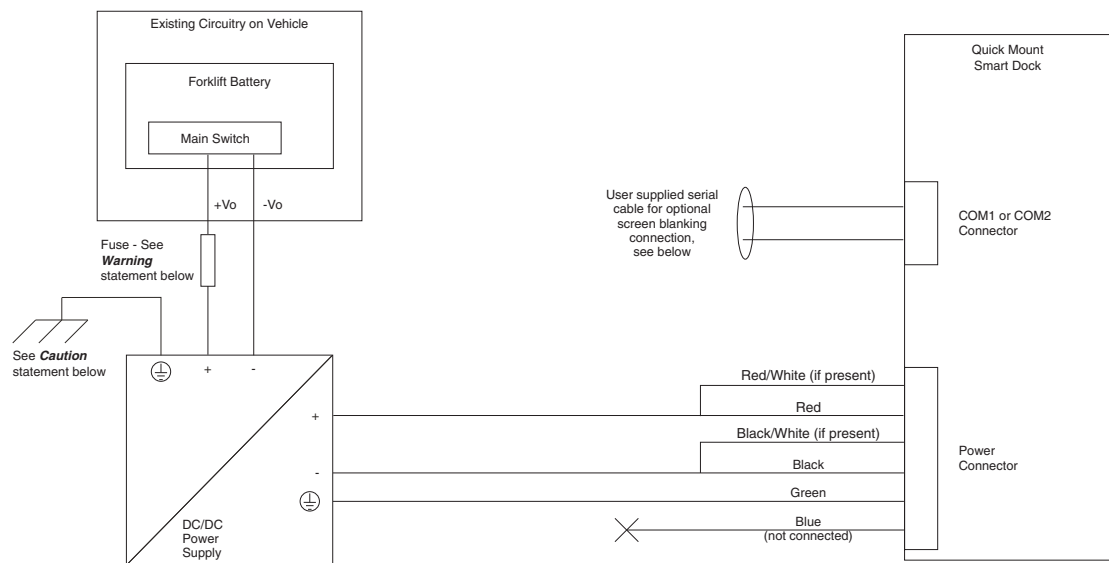

Caution: For battery powered vehicles:

- GND must be connected to the vehicle chassis ground.



Caution: For internal combustion engine powered vehicles:

- GND is connected to the vehicle chassis ground, which can also be battery negative.



Warning: For proper and safe installation, follow the [Fuse Requirements for 50-150 VDC Power Supply, Screws on Top of Lid](#).

VX5/VX6/VX7 Adapter Cable



Caution: These instructions are for use with [VM1D Standard Dock](#) and [VM3D Enhanced Dock](#) only.

An adapter cable (VM1077CABLE) is available to attach the Thor VM3A to a vehicle previously equipped with a VX5/VX6/VX7 DC power cable. The adapter cable has a 5-pin connector to match with the VX5/VX6/VX7 power supply cable on one end and a 6-pin connector to match to the VM3A on the other end. This section assumes the VX5/VX6/VX7 power cable is properly connected to vehicle power. Refer to the X5, VX6, or VX7 Vehicle Mounting Reference Guide for details.



Warning: Because the VX5/VX6/VX7 supports 10-60 VDC power input, verify input voltages before using this adapter cable with an existing VX5, VX6, or VX7 power connection installation.

To Power Connector on Dock

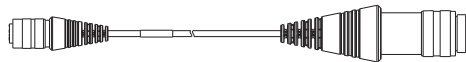

To VX5/VX6/VX7 Power Supply Cable

When this adapter cable is used, there is no provision for an ignition switch input. Therefore the vehicle ignition monitoring function is not available when using this cable.

Connect to VX5/VX6/VX7 Power Cable

1. Connect the adapter cable to the VX5/VX6/VX7 power cable by aligning the connector pins to the power connector; push down on the watertight connector and twist it to fasten securely.
2. The cable is rated for a maximum temperature of 105°C (221°F). Therefore, routing this cable, it should be protected from physical damage and from surfaces that might exceed this temperature. Cable should be protected from physical damage from moving parts. Do not expose the cable to chemicals or oil that may cause the wiring insulation to deteriorate. Always route the cable so that it does not interfere with safe operation and maintenance of the vehicle.

3. Provide mechanical support for the cable by securing it to the vehicle structure at approximately one foot intervals, taking care not to over tighten and pinch conductors or penetrate outer cable jacket.
4. Connect the watertight connector end of the power cable to the dock power connector by aligning the connector pins to the power connector; push down on the watertight connector and twist it to fasten securely.
5. Secure the power cable to the computer using the [Strain Relief Cable Clamps](#).
6. [Place Thor VM3A in the Dock](#)
7. If using the [Screen Blanking Installation](#) feature, install the screen blanking box or switch.
8. [Power On the Computer](#).

Thor VX8/Thor VX9 Adapter Cable



Caution: These instructions are for use with **VM1D Standard Dock** and **VM3D Enhanced Dock** only. This cable is not used for the **VMXD Enhanced Dock**.

An adapter cable is available to attach the Thor VM3A to a vehicle previously equipped with a VX8/VX9 DC power cable. with a screen blanking box installed. If screen blanking is not used, the VX8/VX9 power cable can be connected directly to the dock power connector and an adapter cable is not required. The adapter cable has a 6-pin connector to match the VX8/VX9 power supply cable on one end and a 6-pin connector to match the VM3A on the other end. The cable also has bare wires for ground and ignition sense connection plus a D9 cable to connect to a COM port on the dock to provide a screen blanking signal. This section assumes the VX8/VX9 power cable is properly connected to vehicle power. Refer to the VX8 or VX9 Vehicle Mounting Reference Guide for details.

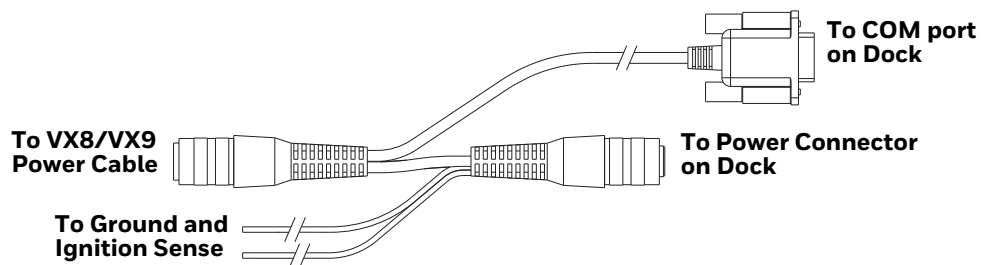

Connect to Thor VX8/VX9 Power Cable

1. Connect the adapter cable to the Thor VX8/VX9 power cable by aligning the connector pins to the power connector; push down on the watertight connector and twist it to fasten securely.
2. Connect the green wire to vehicle ground.



Caution: For battery powered vehicles:

- GND (green wire) must be connected to the vehicle chassis ground.



Caution: For internal combustion engine powered vehicles:

- GND (green wire) is connected to the vehicle chassis ground, which can also be battery negative.
3. If ignition control will be used, connect the blue wire to an ignition switched circuit (less than 1mA over input voltage range). If ignition control is not used, the blue wire can be left disconnected,
 4. If the VX8/VX9 cable is connected to a screen blanking box or switch, connect the D9 connector to a COM port on the dock.
 5. The cable is rated for a maximum temperature of 105°C (221°F). Therefore, when routing this cable, it should be protected from physical damage and from surfaces that might exceed this temperature. Cable should be protected from physical damage from moving parts. Do not expose the cable to chemicals or oil that may cause the wiring insulation to deteriorate. Always route the cable so that it does not interfere with safe operation and maintenance of the vehicle.
 6. Provide mechanical support for the cable by securing it to the vehicle structure at approximately one foot intervals, taking care not to over tighten and pinch conductors or penetrate outer cable jacket.
 7. Connect the watertight connector end of the power cable to the dock power connector by aligning the connector pins to the power connector; push down on the watertight connector and twist it to fasten securely.
 8. Secure the power cable to the computer using the [Strain Relief Cable Clamps](#).
 9. [Place Thor VM3A in the Dock](#).
 10. If using the [Screen Blanking Installation](#) feature, install the screen blanking box or switch if not previously installed.
 11. [Power On the Computer](#).

CV60 Adapter Cable



Caution: These instructions are for use with **VM1D Standard Dock** and **VM3D Enhanced Dock** only.

An adapter cable is available to attach the Thor VM3A to a vehicle previously equipped with a CV60 (VM3078CABLE) DC power cable. The adapter cable has a 5-pin connector to match with the CV60 power supply cable on one end and a 6-pin connector to match to the VM3A on the other end. This section assumes the CV60 power cable is properly connected to vehicle power. Refer to the CV60 documentation for details.

To Power Connector on Dock



To VM3A Power Supply Cable

When this adapter cable is used, there is no provision for an ignition switch input. Therefore the vehicle ignition monitoring function is not available when using this cable.

Connect to CV60 Power Cable

1. Connect the adapter cable to the CV60 power cable by aligning the connector pins to the power connector; push down on the watertight connector and twist it to fasten securely.
2. The cable is rated for a maximum temperature of 105°C (221°F). Therefore, routing this cable, it should be protected from physical damage and from surfaces that might exceed this temperature. Cable should be protected from physical damage from moving parts. Do not expose the cable to chemicals or oil that may cause the wiring insulation to deteriorate. Always route the cable so that it does not interfere with safe operation and maintenance of the vehicle.
3. Provide mechanical support for the cable by securing it to the vehicle structure at approximately one foot intervals, taking care not to over tighten and pinch conductors or penetrate outer cable jacket.
4. Connect the watertight connector end of the power cable to the dock power connector by aligning the connector pins to the power connector; push down on the watertight connector and twist it to fasten securely.
5. Secure the power cable to the computer using the [Strain Relief Cable Clamps](#).
6. [Place Thor VM3A in the Dock](#)
7. If using the [Screen Blanking Installation](#) feature, install the screen blanking box or switch.
8. [Power On the Computer](#).

Screen Blanking Installation

Screen blanking (blackout) can be enabled when the vehicle is in motion. Once screen blanking is enabled, the display is blanked out (or a preselected zoom area is displayed) any time when the cable sends the signal that the vehicle is in motion. If the cable is removed, screen blanking is disabled and the display remains on.

Prerequisite: The steps outlined in either [12-48 VDC Vehicles \(10-60 VDC Direct Connection\)](#), [60-144 VDC Vehicles \(50-150 VDC Power Supply, Screws on Side of Lid\)](#) or [60-144 VDC Vehicles \(50-150 VDC Power Supply, Screws on Top of Lid\)](#) have been completed.

Screen blanking is accomplished by either a Screen Blanking Box or a user supplied switch.



Caution: For installation by trained service personnel only.

Fuse Requirements for Screen Blanking



Warning: For proper and safe installation, the input power lead to the Screen Blanking Box requires a 3 Amp maximum time delay (slow blow) high interrupting rating fuse.

Note: For North America, a UL Listed fuse is to be used. The fuse and the fuse holder must be supplied by the user.

Screen Blanking Cable

Refer to [Screen Blanking](#) to configure the VM3A for screen blanking.

When routing any additional cables for screen blanking:

- Route the cable the shortest way possible removing any left-over cable
- Route the cables so they are protected from physical damage and from surfaces that might exceed the cable's rated temperature threshold.
- Cable should be protected from physical damage from moving parts
- Do not expose the cable to chemicals or oil that may cause the wiring insulation to deteriorate
- Always route the cable so that it does not interfere with safe operation and maintenance of the vehicle.
- Provide mechanical support for the cable by securing it to the vehicle structure at approximately one foot intervals, taking care not to over tighten and pinch conductors or penetrate outer cable jacket.

Honeywell Screen Blanking Box Cable

An optional Honeywell Screen Blanking Box Cable is available (VM1080CABLE).

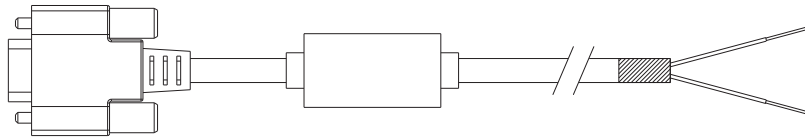

DB9 Female	Function with Screen Blanking Box	Wire color
1 -6, 9	Not Used	
7 (RTS)	Connected to Screen Blanking Box, unswitched side	Black (see note)
8 (CTS)	Connected to Screen Blanking Box, switched side	Gray (see note)

Note: Wire colors only apply to optional Honeywell Screen Blanking Box Cable, VM1080CABLE. Wire colors may vary in a user-supplied cable.

The optional Honeywell Screen Blanking Box Cable, VM1080CABLE, is installed as follows:

1. Connect the gray wire of the cable to the switched side of the Screen Blanking Box.
2. Connect the black wire of the cable to the unswitched side of the Screen Blanking Box.
3. Connect the D9 serial connector to either COM1 or COM2 serial port on the dock.

User-Supplied Cable for Screen Blanking

A user-supplied cable can be used as well. Pins 7 and 8 must be connected as detailed below. No other pins are to be connected.

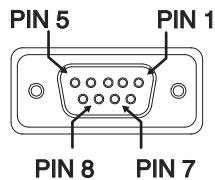

DB9 Female	Function with Screen Blanking Box	Function with Switch
1 -6, 9	Not Used	Not Used
7 (RTS)	Connected to Screen Blanking Box, unswitched side	Connected to Switch
8 (CTS)	Connected to Screen Blanking Box, switched side	Connected to Switch

The user-supplied cable is installed as follows:

1. Connect the wire from Pin 8 of the cable to the switched side of the Screen Blanking Box or to a user-supplied switch.
2. Connect the wire from Pin 7 of the cable to the unswitched side of the Screen Blanking Box or to a user-supplied switch.
3. Connect the D9 serial connector to either COM1 or COM2 serial port on the dock.

Screen Blanking Box

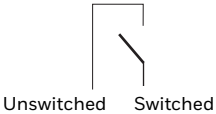
Screen Blanking Box Terminal	Connection
+VI	Input from vehicle motion sensing circuitry. Please refer to label on Screen Blanking Box for allowable voltage input range.
GND	DC -
	<p>These two terminals are for connecting a serial cable:</p> <ul style="list-style-type: none"> • If using an optional Honeywell screen blanking cable, VM1080CABLE, connect the <i>gray</i> wire to the <i>switched</i> side of the connection and connect the <i>black</i> wire to the <i>unswitched</i> side. • If using a user-supplied cable, the cable must be constructed so that Pin 7 (RTS) connects to <i>switched</i> side of the connection and Pin 8 (CTS) connects to the <i>unswitched</i> side.

It is assumed that the motion sensing circuitry in the illustrations below is powered by internal vehicle circuitry.

Please refer to the appropriate illustration below for Screen Blanking Box wiring diagrams.



Warning: Do not exceed the maximum input voltage, either 60 or 72VDC, specified on the Screen Blanking Box label when using this configuration.

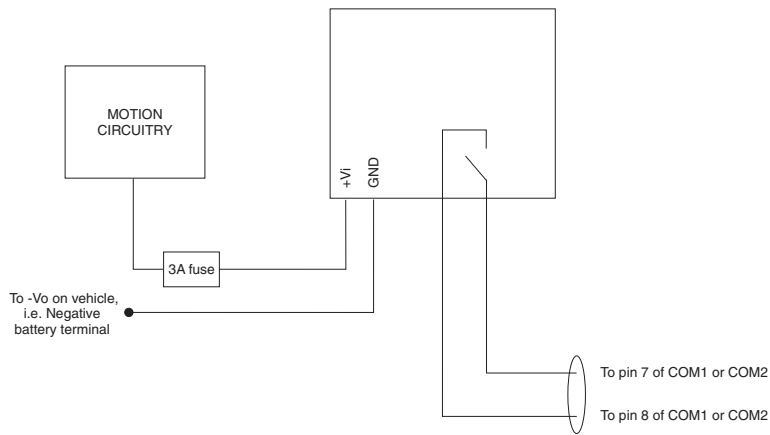

Note: The black and gray wire colors in the illustration only apply to the optional Honeywell Screen Blanking Box Cable, VM1080CABLE. The wire colors may be different in a user-supplied cable.

Screen Blanking with Switch

In applications where it is impractical to use the screen blanking box due to vehicle voltage or lack of a motion sensing signal, screen blanking can be controlled via a user supplied switch or relay that provides an electrical conductive connection on vehicle motion.

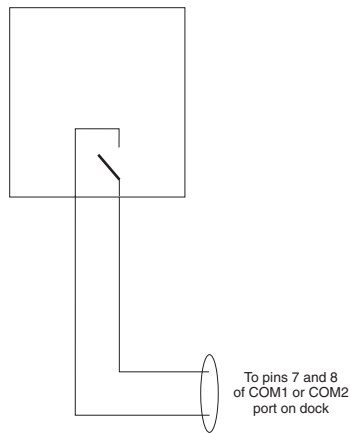

Pins 7 and 8 must be connected as shown in the illustration above. No other pins are to be connected.

Enhanced Dock with Thor VX8/Thor VX9 Screen Blanking



Caution: This dock (VMX004VMCRADLE) is recommended for use when replacing an existing Thor VX8 or Thor VX9 where screen blanking is used. This dock eliminates the need for wiring changes by enabling the existing VX8/VX9 power cable and screen blanking box to be used when the VX8/VX9 is replaced by Thor VM3A. These instructions are for this doc model only! The Ignition Control feature is not available when this dock is used.



Warning: The external DC/DC converter previously used with the Thor VX8 or Thor VX9 must be left in place to provide ground isolations. Connecting the dock power input directly to vehicle power could result in a safety hazard or equipment damage.



Warning: The cable shielding must be connected to chassis ground. Consult the instructions later in this section for the respective power supply type.



Caution: COM1 is used for screen blanking (via the power cable connector) and is unavailable when the screen blanking box is attached. When a screen blanking box is attached, any external serial device, such as a scanner, must be connected to the COM2 port on the dock. If a screen blanking box is not connected via the power cable, the COM1 port on the dock is available for a serial device connection.



Caution: These instructions for use with [Enhanced Dock with Thor VX8/VX9 Screen Blanking](#) only.

Determine the type of power supply used with the previous Thor VX8 or Thor VX9 installation:

- [DC/DC Power Supply with Screws on Top of Lid](#)
- [DC/DC Power Supply with Screws on Side of Lid](#)

DC/DC Power Supply with Screws on Top of Lid



Caution: Inspect the cable shield to verify it is connected to chassis ground. If there is no connection from the cable shield to chassis ground, one must be added at this time. Use a jumper wire to connect the cable shield to chassis ground as shown below for the appropriate type of power supply installed on the vehicle. A jumper wire, as shown in the illustrations below, may be present to attach the chassis ground to the white wire of the power cable. This wire is not necessary but can be left in place if present. For proper screen blanking, verify the yellow and green wires are attached to the screen blanking box as shown in the illustrations below.

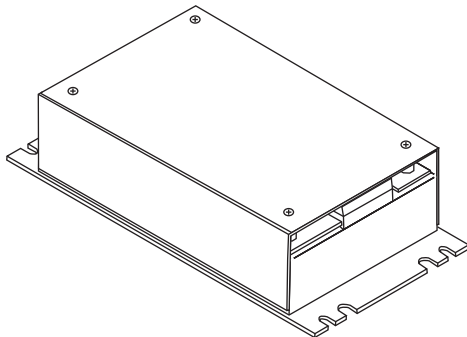

For this model, follow the diagram below to attach the power cable shield to chassis ground:

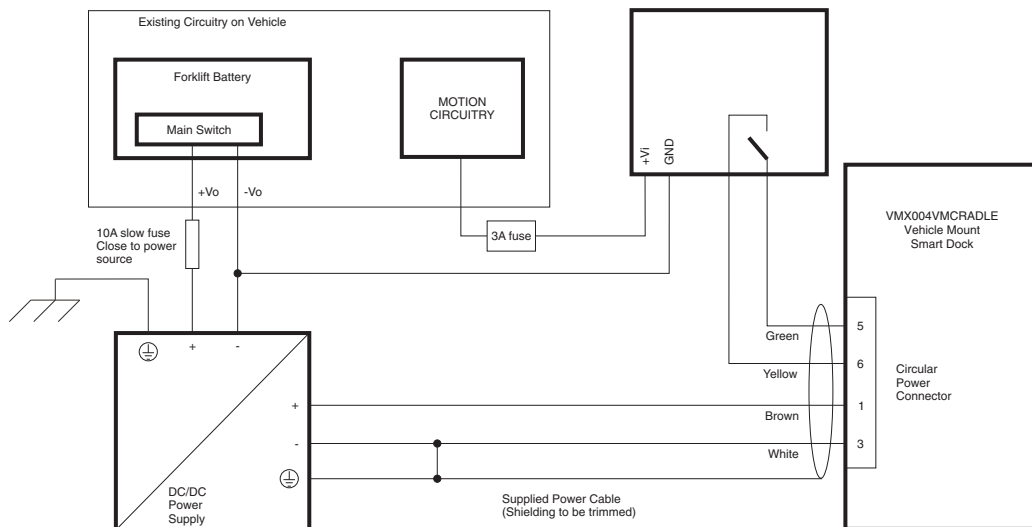

Caution: For battery powered vehicles:

- VIN+ is connected to battery positive.
- VIN- must be connected to battery negative.

- GND must be connected to the vehicle chassis ground.



Caution: For internal combustion engine powered vehicles:

- VIN+ is connected to battery positive.
- VIN- is connected to battery negative.
- GND is connected to the vehicle chassis ground, which can also be battery negative.

DC/DC Power Supply with Screws on Side of Lid



Caution: Inspect the cable shield to verify it is connected to chassis ground. If there is no connection from the cable shield to chassis ground, one must be added at this time. Use a jumper wire to connect the cable shield to chassis ground as shown below for the appropriate type of power supply installed on the vehicle. A jumper wire, as shown in the illustrations below, may be present to attach the chassis ground to the white wire of the power cable. This wire is not necessary but can be left in place if present. For proper screen blanking, verify the yellow and green wires are attached to the screen blanking box as shown in the illustrations below.

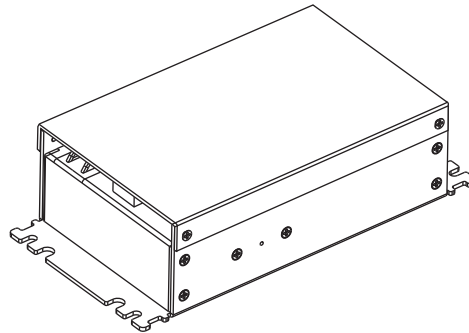

For this model, follow the diagram below to attached the power cable shield to chassis ground:

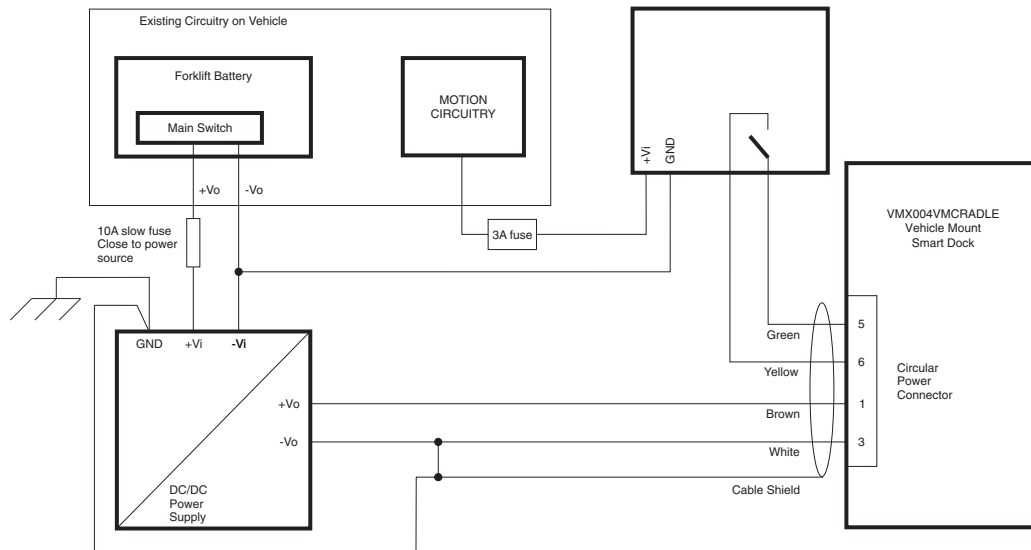

Caution: For battery powered vehicles:

- VIN+ is connected to battery positive.
- VIN- must be connected to battery negative.
- GND must be connected to the vehicle chassis ground.



Caution: For internal combustion engine powered vehicles:

- VIN+ is connected to battery positive.
- VIN- is connected to battery negative.
- GND is connected to the vehicle chassis ground, which can also be battery negative.

External AC/DC Power Supply



Caution: These instructions for use with **VMXD Enhanced Dock for Off-Vehicle Use only.**

The optional external AC/DC power supply is for use in environments, such as an office, where DC power is not available.

Note: *The Honeywell-approved AC/DC Power Supply and Adapter Cable (VM1078CABLE) are only intended for use in a 40°C (104°F) maximum ambient temperature environment.*

In North America, this unit is intended for use with a UL Listed ITE power supply with output rated 15 VDC, 4 Amp (maximum), 60 W (maximum). Outside North America, this unit is intended for use with an IEC certified ITE power supply with output rated 15 VDC, 4 Amp (maximum), 60 W (maximum).

The external power supply may be connected to either a 120V, 60Hz supply or, outside North America, to a 230V, 50Hz supply, using the appropriate detachable cordset. In all cases, connect to a properly grounded source of supply provided with maximum 15 Amp overcurrent protection (10 Amp for 230V circuits).

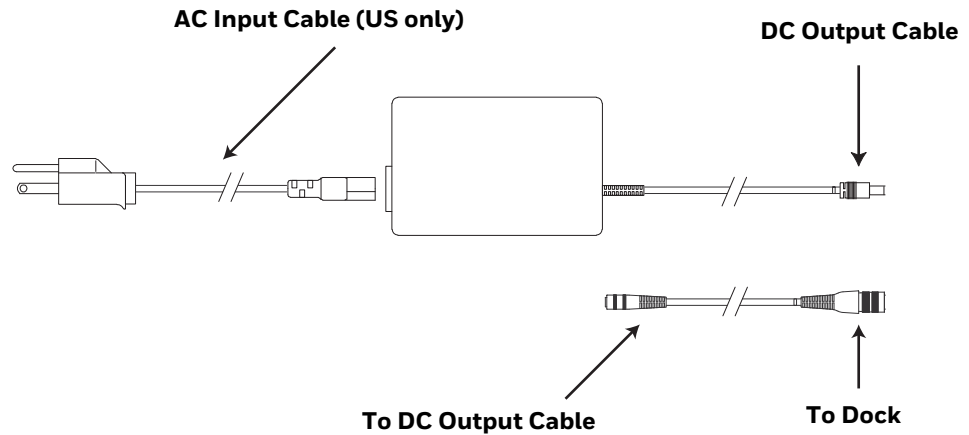

Connect External Power Supply

1. Connect the provided detachable cordset (US only, all others must order cable separately) to the external power supply (IEC 320 connector).
2. Plug cordset into appropriate, grounded, electrical supply receptacle (AC mains).
3. Connect the DC output cable end to the corresponding connector on the adapter cable. (VM1301PWRSPPLY or VM1302PWRSPPLY)
4. Connect the watertight connector end of the Adapter Cable to the VMXD Off-Vehicle Dock power connector by aligning the connector pins to the power connector; push down on the watertight connector and twist it to fasten securely.
5. [Power On the Computer.](#)

Connect USB Host

Host/Client Y Cable

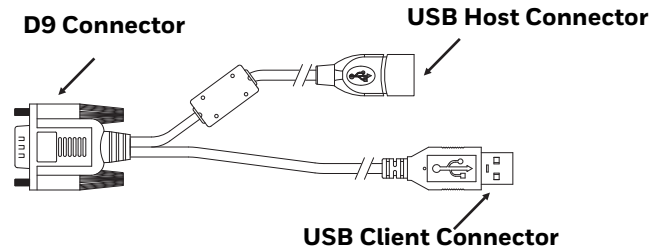

See [USB and USB1 Connector](#) for connector pinouts.

1. Seat the D9 connector firmly over the USB (Standard Dock) or USB1 (Enhanced Dock) connector on the dock.
2. Tighten the thumbscrews in a clockwise direction. Do not over tighten.
3. The USB-host connector provides a connector for a USB device such as a USB thumb drive. The VM3A does not support the USB client port on this cable.
4. Secure the cables to the computer with [Strain Relief Cable Clamps](#).

Dual Host Y Cable

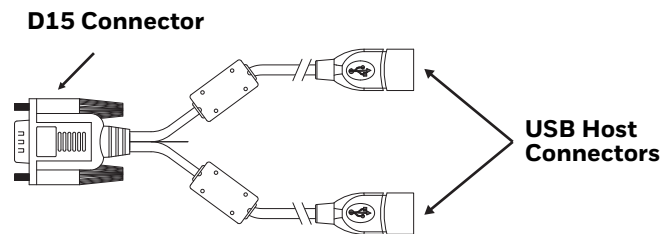

See [USB2 Connector](#) for connector pinouts.

1. Seat the D15 connector firmly over the USB2 (Enhanced Dock only) connector on the dock.
2. Tighten the thumbscrews in a clockwise direction. Do not over tighten.
3. The USB-host connectors provide a connector for a USB device such as a USB thumb drive.
4. Secure the cables to the computer with [Strain Relief Cable Clamps](#).

USB Scanner

There are several ways to attach a USB scanner:

- A USB scanner can be attached to the host port on either USB adapter Y-cable.

- Certain USB scanners can be attached directly to the USB or USB-1 connector using cable CBL-501-300-S00, as shown below.

To use the CBL-501-300-S00 cable:

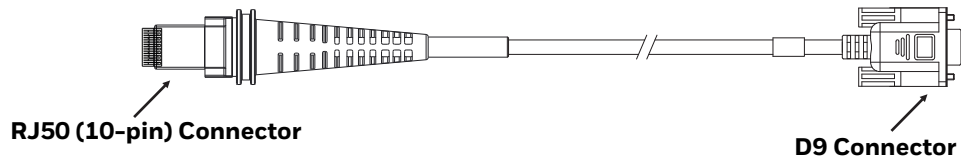

1. Seat the D9 connector of the cable over the USB or USB11 connector on the dock.
2. Tighten the thumbscrews in a clockwise direction. Do not over tighten.
3. Follow the instructions provided with the scanner to attach the RJ50 end of the cable to the scanner.

See [USB Host to Scanner Cable](#) for pinout details.

Connect USB Client

The VM1052CABLE USB Y cable attaches to the dock and provides a type A USB connector.

Connect Serial Device

Note: Pin 9 of the COM port is configured to provide +5V.

See [COM1 and COM2 Connector](#) for connector pinouts.

1. Seat the cable end connector firmly over the serial COM port on the dock.
2. Turn the thumbscrews in a clockwise direction. Do not over tighten.
3. Secure the cables to the computer with [Strain Relief Cable Clamps](#).
4. Connect the other cable end to the desired serial device.

Connect a Tethered Scanner

1. The scanner cable is attached to either the COM1 or COM2 port on the dock.
2. Connect the serial cable for the scanner as directed above.
3. When the computer is powered on, it provides power to the serial scanner.
4. Configure the Data Collection (DC) Wedge to manipulate scanned data as desired.

Connect Headset Cable

The Audio connector supports a headset adapter cable.

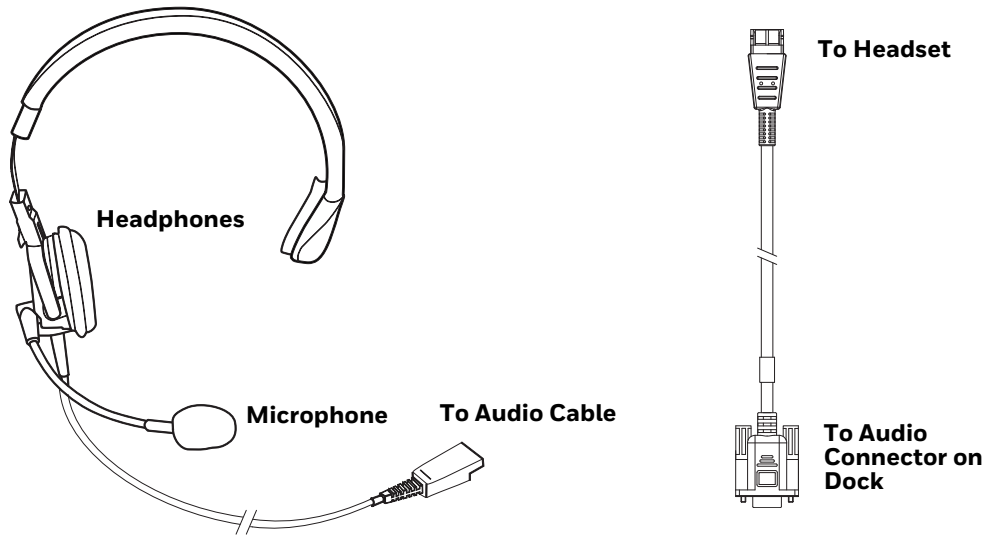

See [Audio Connector](#) for connector pinouts.

1. Seat the D15 cable end connector firmly over the Audio Connector on the dock.
2. Tighten the thumbscrews in a clockwise direction. Do not over tighten.
3. Slide the cable ends together until they click shut. Do not twist or bend the connectors. The internal microphone and speakers are automatically disabled when the headset is connected.

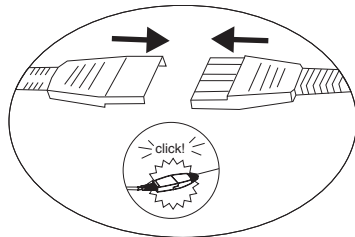

Adjust Headset/Microphone and Secure Cable

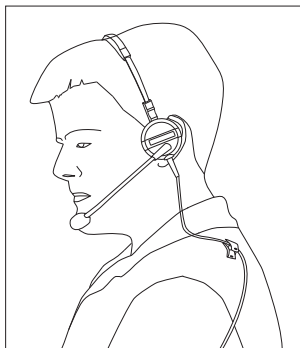

The headset consists of an earpiece, a microphone, a clothing clip, and a cable.

1. Do not twist the microphone boom when adjusting the microphone. The microphone should be adjusted to be about two finger widths from your mouth.
2. Make sure the microphone is pointed at your mouth. Note the small “Talk” label near the mouthpiece. Make sure the Talk label is in front of your mouth. The microphone cable can be routed over or under clothing.
3. Follow the safety guidelines below when wearing the headset.

Under Clothing

- Leave the cable exposed only at the top of the collar.
- Be sure to leave a small loop of cable to allow movement of your head.

Over Clothing

- Use clothing clips to hold the cable close to your body.
- Tuck the cable under the belt, but leave a small loop where it goes under the belt.
- Do not wear the cable on the front of your body. It may get in your way or get caught on protruding objects.

Strain Relief Cable Clamps

Equipment Required: Phillips screwdriver (not supplied by Honeywell)

There are five strain relief cable clamps secured to the Standard Dock.

There is one strain relief cable clamp and three strain relief brackets for securing cables to the Enhanced Dock.

Use the strain relief clamps to secure audio, power, and I/O cables attached to the dock.

Use the left-most strain relief clamp for the power cable.

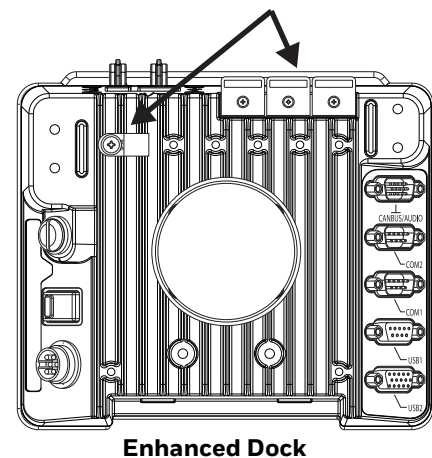
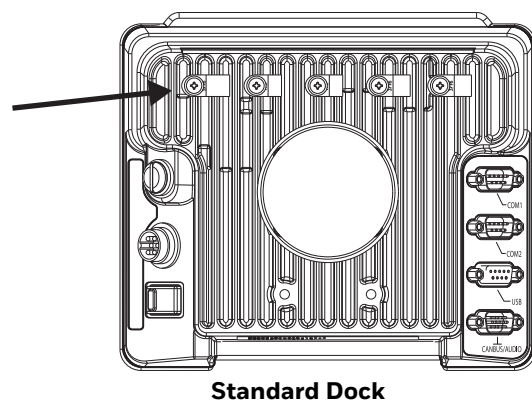

To use the strain relief clamp(s):

1. Determine the proper strain relief cable clamp. There are three sizes of cable clamps on the Standard Dock which should be matched to the cable to be secured. For example, the largest clamp (on the left when viewing the back of the dock) is designed to secure the power cable. For the Enhanced Dock there is a single cable clamp. Use this clamp for the power cable, Use the brackets for all other cables.
2. Remove the strain relief clamp from the computer by turning the screw counterclockwise. Put the screw aside in a safe location.
3. Slide the strain relief clamp over the cable.
4. Using a Phillips screwdriver and the screw that was removed, refasten the clamp holding the cable to the dock. Do not stretch the cable. Leave enough slack in the cable to allow it to be connected and disconnected easily when needed.
5. Continue in this manner until all cables are secured to the dock.

To use the strain relief brackets (Enhanced Dock only):

1. Secure the cable to the bracket with plastic tie straps (cable ties).
2. If necessary, the cable ties can be trimmed to length after installation. Cut the excess tie length off flush and not at an angle to prevent sharp edges that may cause cuts.

