



Chatter **Box!**™





Chatter **Box!**™



 **Bluetooth**

XBI²





XBI²



ChatterBox! strives to provide our customers with powerful and reliable communication systems that offer state-of-the-art technology and cutting edge design. Every communication system in the ChatterBox! product line provides unique features and benefits along with communication compatibility within the entire product range. Each ChatterBox! system is manufactured to exacting standards infusing affordable price, multiple mounting options, intuitive accessories, crystal clear reception, maximum range, compact design and quality. Innovation, rigorous testing protocols, and outstanding customer service are all top priority at ChatterBox!





CONTENTS

- 1. KIT INCLUDES 4**
 - 1.1 OPEN FACE KIT 4
 - 1.2 FULL FACE KIT 4
 - 2. XBI2 DESCRIPTION 5**
 - 2.1 EXTERIOR DESIGN 5
 - 2.2 DESIGN DESCRIPTION 5
 - 2.2.1 POWER Button 5
 - 2.2.2 MODE Button 5
 - 2.2.3 VOLUME UP Button 5
 - 2.2.4 VOLUME DOWN Button 5
 - 2.2.5 INTERCOM Button 5
 - 2.2.6 CHARGE PORT 5
 - 2.2.7 HEADSET PORT 5
 - 2.2.8 LED 5
 - 3. INSTALLATION 6**
 - 3.1 GENERAL INSTALLATION 6-7
 - 3.2 ALTERNATIVE FULL FACE XBI2 UNIT HEADSET INSTALLATION 7
 - 4. BASIC OPERATION 7**
 - 4.1 CHARGING XBI2 UNIT 7-8
 - 4.2 TURNING XBI2 UNIT ON / OFF 8
 - 4.2.1 Turning on 8
 - 4.2.2 Turning off 8
 - 4.3 BATTERY LEVEL STATUS DISPLAY 8
 - 4.4 LOW BATTERY ALERT 9
 - 4.5 ADJUSTING XBI2 UNIT VOLUME 9
 - 5. PAIRING OPERATION 8**
 - 5.1 PUTTING XBI2 UNIT IN BLUETOOTH® PAIRING MODE 8
 - 5.2 PAIRING XBI2 UNITS TOGETHER 9
 - 5.2.1 Pairing 3 XBI2 units together 9
 - 5.2.2 Pairing 2 XBI2 units together 9-10
 - 6. FUNCTION OPERATION 10**
 - 6.1 BLUETOOTH® / WIRED AUDIO DEVICES 10
 - 6.1.1 Pairing a stereo Bluetooth® adaptor 10
 - 6.1.2 Connecting audio source via cable to AUX Port 10
 - 6.1.3 Switching from Bluetooth® mode to AUX mode 10
 - 6.1.4 Switching from Intercom mode to Audio mode 10
 - 6.2 BLUETOOTH® PHONE OPERATION 10
 - 6.2.1 Pairing a Bluetooth® compatible phone 11
 - 6.2.2 Answering a phone call 11
 - 6.2.3 Placing a phone call 11
 - 6.2.4 Placing a last number dialed call 11
 - 7. BLUETOOTH® CONNECTING OPERATION 11**
 - 7.1 CONNECTING A PAIRED STEREO BLUETOOTH® ADAPTOR 11
 - 7.2 CONNECTING A PAIRED BLUETOOTH® PHONE 11-12
 - 7.3 CONNECTING A PAIRED STEREO BLUETOOTH® ADAPTOR AND CONNECTING A PAIRED BLUETOOTH®PHONE AT THE SAME TIME 12
 - 8. SPECIFICATION 12**
 - 8.1 ELECTRICAL SPECIFICATION 12
 - 8.2 PRODUCT SPECIFICATION 12
 - 8.3 BUTTON FUNCTION SUMMARY 13
 - 9. LIMITED WARRANTY 13**
 - 9.1 LIMITED WARRANTY 13
 - 10 LICENSE INFORMATION 14**
 - 10.1 FCC ID 14
 - 10.2 EUROPEAN CE NOTICE 14
 - 10.3 DECLARATION OF CONFORMITY 14
 - 10.4 WARNING 14
 - 11. FREQUENTLY ASKED QUESTIONS 15**
- 

1. KIT INCLUDES

NO.	DESCRIPTION	Q'TY
1	XBi2 Main Unit	1
2	AC Home Charger	1
3	Open Face Headset	1
4	Pre-Installed Lithium-Polymer Battery	1
5	Plastic Base Plate	1
6	Metal Mounting Bracket	1
7	Rubber Pad	1
8	Foam Speaker Covers	2
9	Popsicle Stick	1
10	Phillips Screws	3
11	Double Sided Mounting Tape	1
12	Sticky Back Velcro Discs	2
13	Wire Clips	2

1.1 OPEN FACE KIT



1.2 FULL FACE KIT

NO.	DESCRIPTION	Q'TY
1	XBi2 Main Unit	1
2	AC Home Charger	1
3	Full Face Headset	1
4	Pre-Installed Lithium-Polymer Battery	1
5	Plastic Base Plate	1
6	Metal Mounting Bracket	1
7	Rubber Pad	1
8	Foam Speaker Covers	2
9	Popsicle Stick	1
10	Phillips Screws	3
11	Double Sided Mounting Tape	1
12	Sticky Back Velcro Discs	2
13	Wire Clips	2



2. XBi2 DESCRIPTION

2.1 Exterior Design

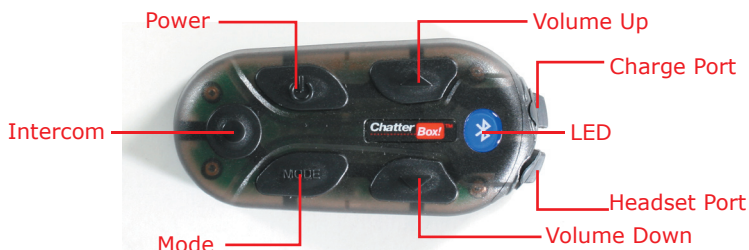

2.2 DESIGN DESCRIPTION

2.2.1 POWER BUTTON

- *Power ON/OFF of main unit
- *BLUETOOTH® pairing mode
- *When the BLUETOOTH® phone is connected, use hands-free mode (Answer/Hang up phone call)
- GROUP INTERCOM pairing mode (with MODE button)

2.2.2 MODE BUTTON

- *MP3 mode source select between BLUETOOTH® MP3 and AUX MP3
- *GROUP INTERCOM pairing mode (with POWER button)

2.2.3 VOLUME UP BUTTON

- *Audio volume increase

2.2.4 VOLUME DOWN BUTTON

- *Audio volume decrease

2.2.5 INTERCOM BUTTON

- *GROUP INTERCOM select – voice communication with other XBi2
- *MP3 mode

2.2.6 CHARGE PORT

- *Primary Function = charge cord port
- *Secondary Function = optional auxiliary audio cord input

2.2.7 HEADSET PORT

- *Primary Function = headset cord port

2.2.8 LED

- *RED = Primary Function = XBi2 unit On/Off status
Secondary Function = GROUP INTERCOM pairing status
- *BLUE = Primary Function = BLUETOOTH® status
Secondary Function = charging status

3. INSTALLATION

Figure 1

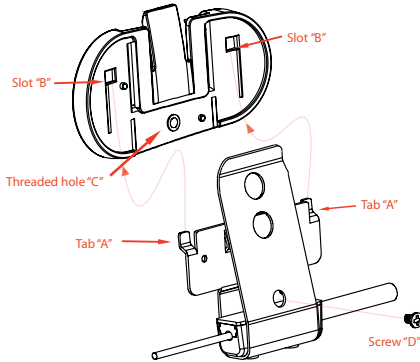

3.1 GENERAL INSTALLATION

1. Attach plastic base plate to metal mounting bracket by aligning tabs "A" with slots "B" and sliding plastic base plate onto metal mounting bracket. Insert screw "D" through metal mounting bracket and into threaded hole "C" and tighten. (Figure 1)

2. Attach the foam covers and sticky backed velcro discs to the speakers. (Figure 2)

3. Place the helmet upside down on a soft surface. The metal mounting bracket should be placed at approximately the middle of the left side of the helmet. Insert the inner metal portion of the metal mounting bracket between the inside of the outer shell and the inner liner of the helmet, slide the metal mounting bracket all the way in while holding the outer portion away from the helmet. (Figure 3)

Figure 2



Figure 3



4. Slide rubber pad between outer shell of helmet and the outer portion of the metal mounting bracket.

5. Attach the RIGHT speaker (the long wire) to the inside of the helmet. Attach the LEFT (the short wire) to the inside of the helmet.

6. Slide XBi2 unit onto the plastic base plate and plug the headset into the headset port. Use the popsicle stick to gently tuck the speaker wires between the inner liner and the outer shell of the helmet.



3.2 ALTERNATIVE FULL FACE XBi2 UNIT HEADSET INSTALLATION

1. Attach double sided mounting tape to the back side of the plastic base plate. Position the plastic base plate at approximately the middle bottom of the left side of the helmet and apply.
2. Install speakers at stated in step 2 & 5 of the previous instructions.
3. Position and attach the microphone to the middle of the helmet chin bar directly in front of the mouth. Use the popsicle stick to gently tuck the microphone wire between the inner liner and the outer shell of the helmet.
4. Slide XBi2 unit onto the plastic base plate and plug the headset into the headset port. Use the popsicle stick to gently tuck the speaker wires between the inner liner and the outer shell of the helmet.



***** CHARGE XBi2 UNIT BEFORE PERFORMING ANY OPERATIONS *****

****READ THROUGH INSTRUCTIONS COMPLETELY BEFORE ATTEMPTING OPERATIONS****

***** DO NOT ATTEMPT TO OPERATE UNIT WHILE CHARGING *****

***** DAMAGE TO UNIT OR AC CHARGER MAY OCCUR *****

4. BASIC UNIT OPERATION

4.1 CHARGING XBi2 UNIT

1. XBi2 unit must be off
2. Plug charger into household power supply, then plug charge cord into the charge port of the XBi2
3. LED display on the XBi2 / charger
 - XBi2 Unit
 - BLUE LED will remain on until XBi2 is done charging
 - Charger
 - RED LED- XBi2 is charging
 - GREEN LED- XBi2 is done charging
4. For a complete charge it will take approximately 3 hours





4.2 TURNING XBI2 UNIT ON / OFF

4.2.1 TURNING ON

1. Press and hold the Power button until LED lights steady RED
2. Release Power button
3. LED will now alternate flashing BLUE & flashing RED continuously

4.2.2 TURNING OFF

1. Press and hold the Power button until LED lights steady RED
2. A two-tone sound will be heard
3. Release Power button
4. LED will now be off

4.3 BATTERY LEVEL STATUS DISPLAY

1. Press the Power button around 1second, RED LED will stay "ON" then release the Power button.
2. Please refer to the table below for BATTERY LEVEL STATUS

NO.	LEVEL	STATUS	VOLTAGE [V]	BLUE LED
1	3/3	BATTERY Full	Over 3.86V	3 times ON/OFF
2	2/3	BATTERY 2/3	3.54V ~ 3.86V	2 times ON/OFF
3	1/3	BATTERY 1/3	3.34V ~ 3.54V	1 times ON/OFF
4	0/3	Low BATTERY ALERT	Below 3.34V	1 times ON/OFF

4.4 LOW BATTERY ALERT

1. If the voltage of the main unit is entering $+3.2V \pm 0.1V$, you will hear the first alarm beep sound from the speaker.
2. After the first beep, if the voltage is entering $+3.1V \pm 0.1V$, the power will turn OFF automatically.

4.5 ADJUSTING UNIT VOLUME

1. XBi2 unit will be at middle volume level whenever unit is turned on
2. Momentarily press (approximately 1 second) and release the volume button
3. A single tone sound will be heard for each level
4. At maximum volume level a two tone sound will be heard

5. BLUETOOTH® PAIRING OPERATION

5.1 PUTTING XBI2 INTO BLUETOOTH® PAIRING MODE

1. Start with XBi2 unit off
2. Press and hold Power button until LED light is steady RED then after approximately 6 seconds LED will start to flash BLUE
3. Release Power button and the XBi2 is now in Bluetooth® pairing mode





5.2 PAIRING XBI2 UNITS TOGETHER

***** MAIN UNIT MUST BE ON AT ALL TIMES TO COMMUNICATE BIKE-TO-BIKE *****

5.2.1 PAIRING 3 XBI2 UNITS TOGETHER - RIDER:1 (MAIN) RIDER:2 (SATELLITE 1) RIDER:3 (SATELLITE 2)

1. Turn on Main, Satellite (1) and Satellite (2) units on
2. Get the Main unit. Press & hold the Power button and the Mode button simultaneously
3. LED will start to flash RED and occasional BLUE after 3 seconds
4. Release both Power button and the Mode button
5. Now get the Satellite (1) unit. Press the Power button and the Mode button simultaneously for one second *
6. LED will start to flash
7. Immediately get the second Satellite (2) unit. Press the Power button and the Mode button simultaneously for one second *
8. LED will start to flash
9. If pairing sequence was done correctly all three XBi2 units will turn themselves off
First: Satellite (1)
Second: Satellite (2)
Third: Main
10. Pairing is now complete, XBi2 units are now paired and will connect to each other automatically when units are on and within range of each other

5.2.2 PAIRING 2 XBI2 UNITS TOGETHER - RIDER:1 (MAIN) RIDER:2 (SATELLITE)

***** MAIN UNIT MUST BE ON AT ALL TIMES TO COMMUNICATE BIKE-TO-BIKE *****

1. Turn both Main and Satellite unit on
2. Get the Main unit. Press & hold the Power button and the Mode button simultaneously
3. LED will start to flash RED and occasional BLUE after 3 seconds
4. Release both Power button and the Mode button
5. Immediately get the Satellite unit. Press the Power button and the Mode button simultaneously for one second *
6. LED will start to flash then unit turns itself off quickly
7. The main unit will turn itself off 8-10 second after the Satellite unit is off
8. Pairing is now complete
9. XBi2 units are now paired and will connect to each other automatically when both units are on and within range of each other

* Do not delay the process or the XBi2 units will go on timeout mode and need to start the pairing process over





6. FUNCTION OPERATION

6.1 BLUETOOTH® / WIRED AUDIO DEVICE

***** ALWAYS PAIR STEREO AUDIO SOURCE TO XBi2 BEFORE PAIRING PHONE *****

6.1.1 PAIRING A STEREO BLUETOOTH® ADAPTOR

1. Put XBi2 unit in Bluetooth® pairing mode (turn to 5.1)
2. Turn on audio source and connect Bluetooth® adaptor for pairing
3. Audio source will automatically start playing through XBi2 unit when pairing is complete
4. XBi2 unit is now paired with Bluetooth® adaptor. (Pairing process will no longer be needed to connect)

6.1.2 CONNECTING AUDIO SOURCE VIA CABLE TO AUX PORT

1. Connect audio cable between the AUX input and the audio source
2. Turn on both XBi2 unit and Audio source
3. Audio source will automatically start playing through XBi2 unit

6.1.3 SWITCHING FROM BLUETOOTH® MODE TO AUX MODE

1. Press the Mode button around 1 second, it will switch from Bluetooth® mode to AUX mode. A 4 tone sound will be heard
2. Press the Mode button around 1 second, it will switch from AUX mode to Bluetooth® mode. A 4 tone sound will be heard

6.1.4 SWITCHING FROM INTERCOM MODE TO AUDIO MODE

1. Press the Intercom button around 1 second, it will switch from Audio mode to Intercom mode. A 2 tone sound will be heard
2. Press the Intercom button around 2 seconds, it will switch from Intercom mode to Audio mode. A 4 tone sound will be heard

6.2 BLUETOOTH® PHONE OPERATION

****INTERCOM COMMUNICATION IS NOT AVAILABLE DURING PHONE USE****

6.2.1 PAIRING A BLUETOOTH® COMPATIBLE PHONE

1. Put XBi2 unit in Bluetooth® pairing mode (turn to 5.1)
2. Press search for Bluetooth® devices button on phone
3. Select "XBi2" from phone device list
4. Enter pass code in phone (pass code will be "0000")
5. Press connect to "XBi2" on phone
6. XBi2 unit is now paired to the phone. (Pairing process will no longer be needed to connect)





6.2.2 ANSWERING A PHONE CALL

1. When a phone call is received a 3 tone sound will be heard
2. Momentarily press (approximately 1 second) and release the Power button
3. Stereo audio source and/or intercom communication will be muted
4. Conduct phone call
5. To end call, momentarily press (approximately 1 second) and release the Power button
6. Stereo audio source and/or intercom communication will be restored

6.2.3 PLACING A PHONE CALL *

1. Dial desired number and press talk or connect on phone keypad
2. Stereo audio source and/or intercom communication will be muted
3. Conduct phone call
4. To end call, momentarily press (approximately 1 second) and release the Power button
5. Stereo audio source and/or intercom communication will be restored

6.2.4 PLACING A LAST NUMBER DIALED CALL

1. Momentarily press (approximately 1 second) and release the Power button
2. Stereo audio source and/or intercom communication will be muted
3. Conduct phone call
4. To end call momentarily press (approximately 1 second) and release the Power button
5. Stereo audio source and/or intercom communication will be restored

* We do not recommend placing a phone call while riding*

** ALWAYS CONNECT STEREO AUDIO SOURCE TO XBi2 BEFORE CONNECTING PHONE **

AUDIO SOURCES WITH BUILT-IN BLUETOOTH® WILL CONNECT SIMILAR TO PHONES

7. BLUETOOTH® CONNECTING OPERATION

7.1 CONNECTING A PAIRED STEREO BLUETOOTH® ADAPTOR

1. Turn XBi2 unit on
2. Turn on audio source and turn on or plug in stereo Bluetooth® adaptor
3. Audio source will automatically start playing through the XBi2 unit when connection is complete

7.2 CONNECTING A PAIRED BLUETOOTH® PHONE

1. Turn XBi2 unit on
2. Momentarily press (approximately 1 second) and release the Power button *
3. Bluetooth® symbol will light up on phone display
4. Press end call button on phone



7.3 CONNECTING A PAIRED STEREO BLUETOOTH® ADAPTOR AND PAIRED BLUETOOTH® PHONE AT THE SAME TIME

1. Turn XBi2 unit on
2. Turn on audio source and turn on or plug in stereo Bluetooth® adaptor
3. Audio source will automatically start playing through the XBi2 unit when connection is complete
4. Momentarily press (approximately 1 second) and release the Power button *
5. Bluetooth® symbol will light up on phone display
6. Press end call button on phone

* When doing this procedure some phones will try to dial the last number dialed. Once connected be prepared to press the end call button on your phone

8. SPECIFICATION

8.1 ELECTRICAL SPECIFICATION

NO.	PARAMETER	BLUETOOTH®	BINARY CDMA	REMARK
1	FREQUENCY RANGE	2402 ~ 2480 MHz	2403 ~ 2477 MHz	
2	POWER OUTPUT	+0dBm CLASS 2	+10dBm CLASS 1	
3	RECEIVE SENSITIVITY	- 82 dBm	- 83 dBm	0.1% BER
4	SERVICE AREA	Within 10 m	Within 100 m	L.O.S.
5	PROFILE	HFP, HSP, A2DP		
6	CURRENT CONSUMPTION	50 mA	110 mA	
7	OPERATING TEMP.	-10 ~ +55 °C	-10 ~ +80 °C	

8.2 PRODUCT SPECIFICATION

NO.	FUNCTION	CONDITION	SPECIFICATION	REMARK
1	DC IN			
2	OPERATING VOLTAGE		+3.1V ~ +4.2 V	
3	BATTERY		Li-Polymer 630mAh	
4	AUDIO POWER		120mW [max.]	@ 32Ω
5	CHARGING TIME		3 hours	
6	OPERATION TEMP.		-10 ~ +55 °C	
7	OPERATING TIME	Stand-by	15-16 hours	
		Continuity	6-7 hours	

8.3 BUTTON FUNCTION SUMMARY

NO.	BUTTONS	DESCRIPTION	TIME	LED & BEEP	REMARK
1	POWER	POWER ON	1 sec ↑	RED + BLUE	RED LED ON
		POWER OFF	5 sec ↑	RED + BLUE	RED LED ON
		Hands-Free	1 sec ↓	-	Make Call, Answer Call
		BLUETOOTH® PARING	7 sec ↑	BLUE	BLUETOOTH® Pairing Mode Entering
2	POWER & MODE	GROUP MASTER	2 sec ↑	RED [200ms]	GROUP INTERCOM Pairing Mode Entering (After finish Auto Power OFF)
		GROUP SLAVE	1 sec ↓	RED[100ms]	
3	MODE	BLUETOOTH® MP3 Select	4 sec ↓	4-Tone	In MP3 MODE
		AUX. MP3 Select	4 sec ↑	4-Tone	In MP3 MODE
4	VOLUME UP	Volume Increase	1 sec ↓	1-Tone	Audio Output Power Increase (15 LEVEL)
5	VOLUME DOWN	Volume Decrease	1 sec ↓	1-Tone	Audio Output Power Increase (15 LEVEL)
6	INTERCOM	GROUP INTERCOM Select	1 sec ↓	2-Tone	
		MP3 MODE Select	2 sec ↑	4-Tone	MP3 Mode Entering

9. LIMITED WARRANTY

9.1 LIMITED WARRANTY

ChatterBox! USA warrants that each new ChatterBox! Will be free from defective materials and workmanship for a period of one (1) year from the date of original purchase. ChatterBox! USA will remedy any such defect by repair or replacement (at our discretion) of the products, provided they are delivered to the address listed below, intact for examination, with all transportation charges prepaid and accompanied by a copy of the original retail sales receipt. The provisions of this warranty shall not apply to any unit which has been subject to misuse, neglect, incorrect installation, unauthorized modifications, accident, or has been repaired or altered outside of our facilities. The express warranty contained herein is in lieu of all other warranties, expressed, implied or statutory, including without limitation any warranty of merchantability or fitness for a particular use. In no event will ChatterBox! USA be liable to the buyer for any damages, including special, incidental, indirect, or consequential.



10. LICENSE INFORMATION

10.1 FCC ID# KA9HJC-XBi2

* This device has been tested and found to comply with the limits for a class b digital device pursuant to part 15 of the FCC rules

* Operation is subject to the following two conditions

(1) This device may not cause harmful interference

(2) This device must accept any interference received including interference that may cause undesired operation

* Any changes or modifications not expressly approved by the parties responsible for compliance could void the users authority to operate this device

10.2 EUROPEAN CE NOTICE

* This device is in conformity with the following essential requirements of council directive 1999/5/ec articles 3.1a, 3.1b, and 3.2

* This device is manufactured in accordance with annex II of the above directive

10.3 DECLARATION OF CONFORMITY (DOC)

*This device is compliant with and adopts the Bluetooth® specification 2.0 and has successfully passed all interoperability tests that are specified in the Bluetooth® specification

*Interoperability between this device and other Bluetooth® enabled products is not guaranteed

10.4 WARNING

*Please check all local laws and regulations regarding the use of in-helmet speakers while operating motorized vehicles

**ChatterBox! USA
16918 Edwards Road
Cerritos, CA 90703**



11. FREQUENTLY ASKED QUESTIONS

QUESTIONS	ANSWERS
1) How many XBi2 units can communicate to each other?	1) You can have up to 3 XBi2 units to communicate to each other.
2) What is the range of the XBi2?	2) The XBi2 units can communicate up to 500 meters in optimum conditions.
3) Why does the LED light on the XBi2 not turning off, no matter what I do?	3) You will need to unscrew the 4 screws and unplug the battery to hard reset the unit.
4) Can I use more than one audio device at a time?	4) No, you can only do one audio device at a time. Its either through Bluetooth® or hardwired.
5) What has the highest priority?	5) Highest: Phone; Second: Intercom; Lowest: Audio.
6) Is there a charging indicator on XBi2 unit?	6) Yes, the LED light on the unit will light BLUE if its charging and will turn itself off when the unit is fully charged
7) If I get caught in a rainstorm will the XBi2 unit get damaged?	7) No, the XBi2 unit will not get damaged. It has a waterproof case.
8) If I don't have a Bluetooth® enabled audio source, is there an AUX port to hardwire my audio device?	8) Yes, there is an AUX port to hardwire your audio device. You will need the CBAUDO (sold separately).
9) Will the XBi2 unit pair with the XBi or the GMRS X1 Bluetooth®?	9) No, the three units will not pair together. All three units use different frequencies.
10) I have a Bluetooth® enabled audio device. Will it be compatible with the XBi2 unit?	10) You will have to read through the owner's manual of your audio device. To see if your audio device is A2DP. A2DP is a Bluetooth® profile that allows audio signal to be transferred via Bluetooth®.
11) I have a Garmin Zumo 550. Can I pair that with the XBi2?	11) Yes, the Garmin Zumo 550 is compatible with the XBi2. You will hear your voice prompts, built-in MP3 player, and have the ability to use your phone. The only thing that will NOT stream via Bluetooth® is the XM radio.
12) When you say, you can pair 2 Bluetooth® devices simultaneously that means I can pair 2 Bluetooth® audio dongles together?	12) No, when we say 2 Bluetooth® devices that means you can pair 1 device under the hands-free profile (cell phone) and 1 device under the stereo profile (MP3 player, GPS, or radar).