

FOR MODEL :

FS 50



HORIZON
FITNESS

HOME GYM ASSEMBLY AND USER'S GUIDE

INTRODUCTION

CONGRATULATIONS and **THANK YOU** for your purchase of this Horizon home gym!

Whether your goal is to tone your muscles, increase your strength or simply enjoy a fuller, healthier lifestyle, a Horizon home gym can help you attain it – adding club-quality performance to your at-home workouts, with the ergonomics and innovative features you need to get stronger and healthier, faster. Because we're committed to designing fitness equipment from the inside out, we use only the highest quality components. It's a commitment we back with one of the strongest warranty packages in the industry.

You want exercise equipment that offers the most comfort, the best reliability and the highest quality in its class.

A Horizon home gym delivers.

TABLE OF CONTENTS

<i>Important Precautions</i>	<i>4</i>
<i>Assembly</i>	<i>5</i>
<i>Before You Begin</i>	<i>17</i>
<i>Conditioning Guidelines</i>	<i>18</i>
<i>Troubleshooting & Maintenance</i>	<i>24</i>
<i>Limited Warranty</i>	<i>26</i>
CONTACT INFORMATION	<i>Back Panel</i>

IMPORTANT SAFETY INSTRUCTIONS

FOR HOUSEHOLD USE ONLY

SAVE THESE INSTRUCTIONS

Read all instructions before using this home gym. Basic precautions should always be followed, including the following: Read all instructions before using this home gym. It is the responsibility of the owner to ensure that all users of this home gym are adequately informed of all warnings and precautions. If you have any questions after reading this manual, contact customer service at the number listed on the back cover of this manual.



! WARNING TO REDUCE THE RISK OF INJURY TO PERSONS:

- Close supervision is necessary when this home gym is used by, on, or near children, invalids, or disabled persons.



At NO time should pets or children under the age of 12 be closer to the home gym than 10 feet.
At NO time should children under the age of 12 use the home gym.
Children over the age of 12 should not use the home gym without adult supervision.

- Use this appliance (or home gym) only for its intended use as described in this manual. Do not use attachments not recommended by the manufacturer.
- Never drop or insert any object into any opening.
- If you experience any kind of pain, including but not limited to chest pains, nausea, dizziness, or shortness of breath, stop exercising immediately and consult your physician before continuing.
- Do not wear clothes that might catch on any part of the home gym.
- Always wear athletic shoes while using this equipment.
- Do not jump on the home gym.
- At no time should more than one person be on home gym while in operation.
- The home gym should not be used by persons weighing more than 300 pounds. Failure to comply will void the warranty.
- The home gym is intended for in-home use only. Do not use this home gym in any commercial, rental, school or institutional setting. Failure to comply will void the warranty.
- Do not use outdoors.

ASSEMBLY

IMPORTANT: READ THESE SAFETY INSTRUCTIONS BEFORE USE!



During the assembly process there are several areas that special attention must be paid. It is very important to follow the assembly instructions correctly and to make sure all parts are firmly tightened. If the assembly instructions are not followed correctly, the home gym could have frame parts that are not tightened and will seem loose and may cause irritating noises. There should be no side-to-side play in the frame uprights. If there is any play in these areas, the home gym has not been properly assembled. To prevent damage to the home gym, the assembly instructions must be reviewed and corrective actions should be taken.

UNPACKING

Unpack the unit where it will be used. Place the home gym carton on a level flat surface. It is recommended that you place a protective covering on your floor. Take CAUTION when handling and transporting this unit. Never open box when it is on its side. FAILURE TO FOLLOW THESE INSTRUCTIONS COULD RESULT IN INJURY!

Before proceeding, find your home gym's serial number and model name located on the left rear side of the base frame and enter it in the space provided below.

ENTER YOUR SERIAL NUMBER AND MODEL NAME IN THE BOXES BELOW:

SERIAL NUMBER:

MODEL NAME:

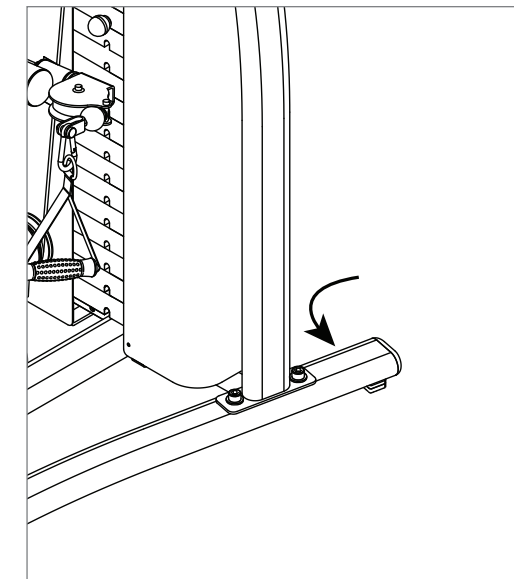

* Refer to the SERIAL NUMBER and MODEL NAME when calling for service.

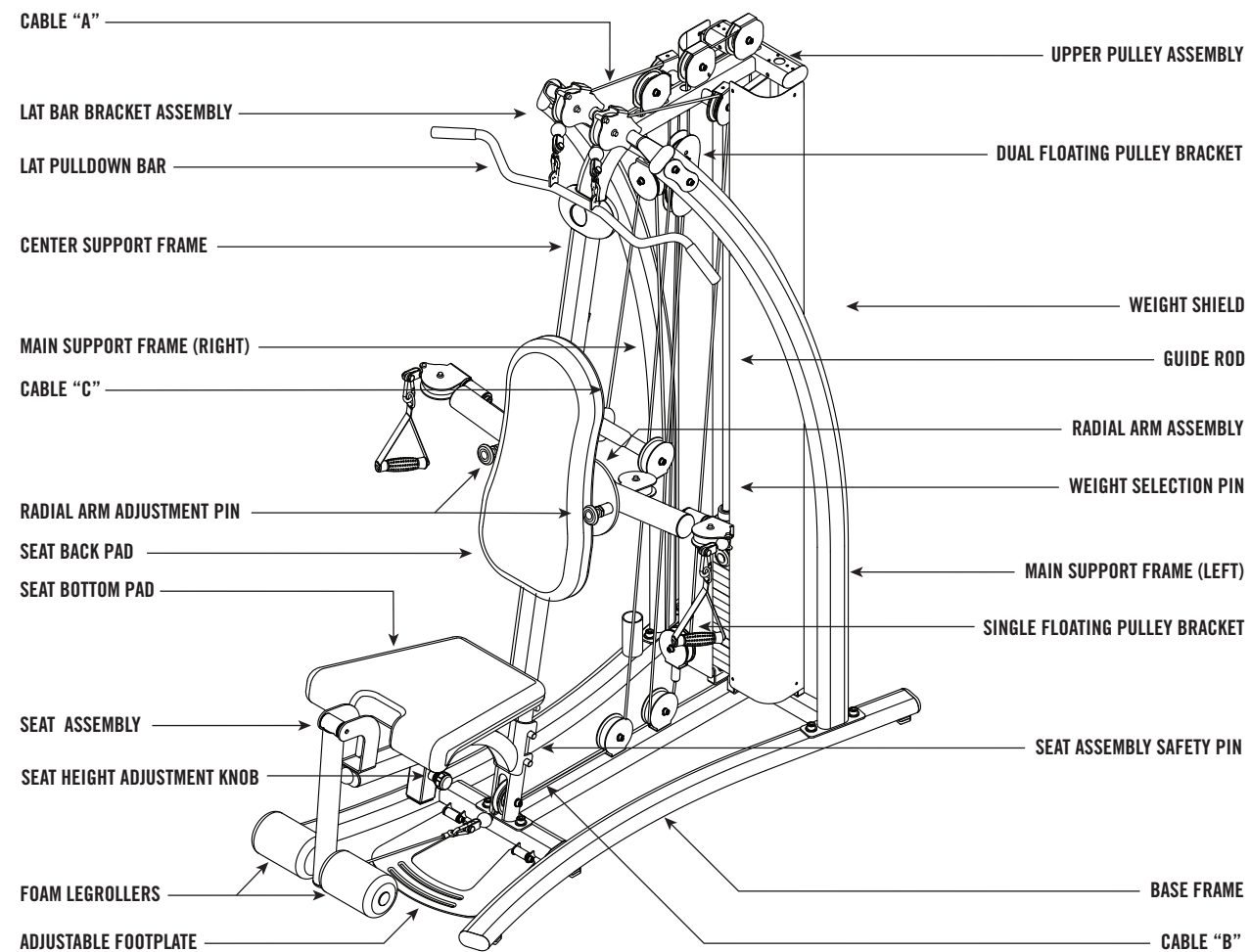

TOOLS INCLUDED

- | | |
|--|--|
| <input type="checkbox"/> Screwdriver | <input type="checkbox"/> 4 mm Allen Wrench |
| <input type="checkbox"/> 19 mm Flat Wrench | <input type="checkbox"/> 6 mm Allen Wrench |
| <input type="checkbox"/> 13 mm/17 mm Flat Wrench | <input type="checkbox"/> 8 mm Allen Wrench |

PARTS INCLUDED

- | | | |
|---|---|---|
| <input type="checkbox"/> 1 Seat Assembly Safety Pin | <input type="checkbox"/> 1 Center Upright | <input type="checkbox"/> 1 Single Floating Pulley Bracket |
| <input type="checkbox"/> 2 Foam Rollers | <input type="checkbox"/> 1 Seat Assembly | <input type="checkbox"/> 1 Upper Pulley Assembly (Multiple Pulleys) |
| <input type="checkbox"/> 1 Seat Back Cushion | <input type="checkbox"/> 3 Weight Shields | <input type="checkbox"/> 3 Cables |
| <input type="checkbox"/> 1 Main Base Frame | <input type="checkbox"/> 2 Guide Rods | |
| <input type="checkbox"/> 1 Main Support Frame (Right) | <input type="checkbox"/> 1 Weight Selection Pin | |
| <input type="checkbox"/> 1 Main Support Frame (Left) | <input type="checkbox"/> 1 Upper Pulley Bracket | |
| <input type="checkbox"/> 1 Radial Arm Assembly | <input type="checkbox"/> 1 Dual Floating Pulley Bracket | |

If you have questions or if there are any missing parts, contact Customer Tech Support. Contact information is located on the back panel of this manual.

For a complete exploded diagram, visit us at www.horizonfitness.com

PRE-ASSEMBLY

NOTE: During each assembly step, ensure that ALL nuts and bolts are in place and partially threaded in before completely tightening any ONE bolt. NOTE: A light application of grease may aid in the installation of hardware. Any grease, such as lithium bike grease is recommended.

ASSEMBLY STEP 1

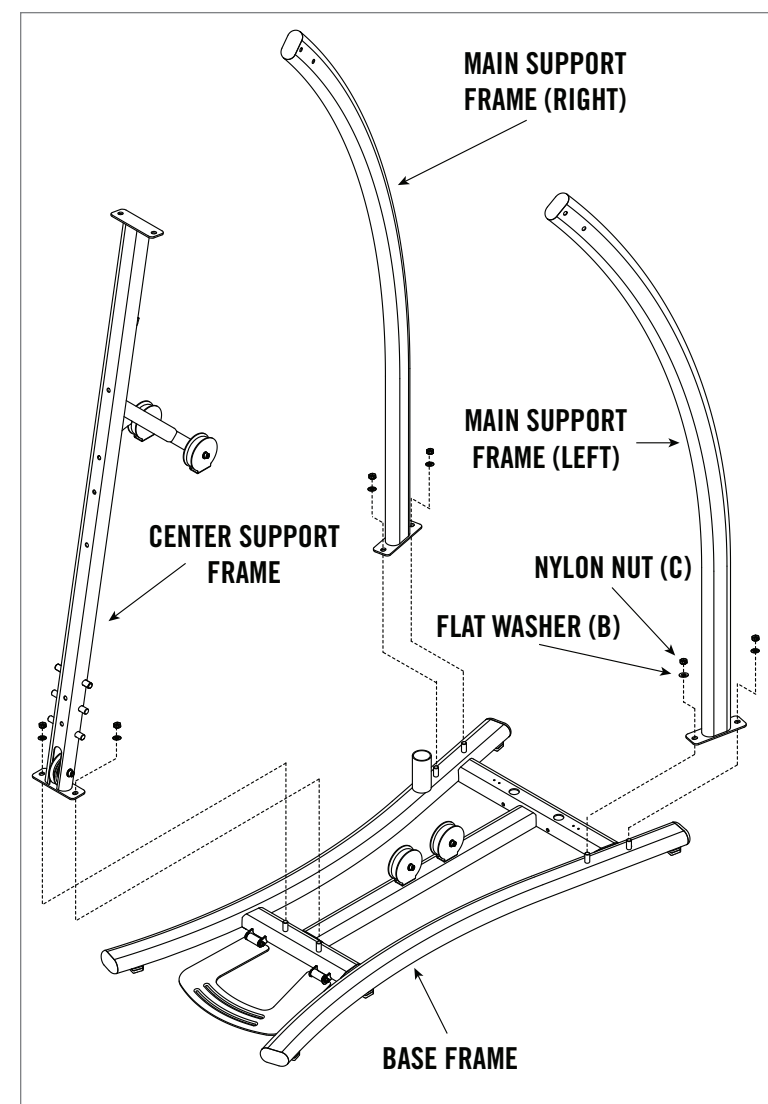

- Place **BASE FRAME** on floor in desired location.
- Remove 6 **NYLON NUTS (C)** and 6 **FLAT WASHERS (B)** from **BASE FRAME**.
- Attach **RIGHT MAIN SUPPORT FRAME** to right side of **BASE FRAME** using 2 **BOLTS (A)**, 2 **FLAT WASHERS (B)** and 2 **NYLON NUTS (C)**.
- Repeat on other side.
- Attach **CENTER SUPPORT FRAME** to **BASE FRAME** using 2 **BOLTS (A)**, 2 **FLAT WASHERS (B)** and 2 **NYLON NUTS (C)**.

ASSEMBLY STEP 2

HARDWARE BAG 1 CONTENTS :

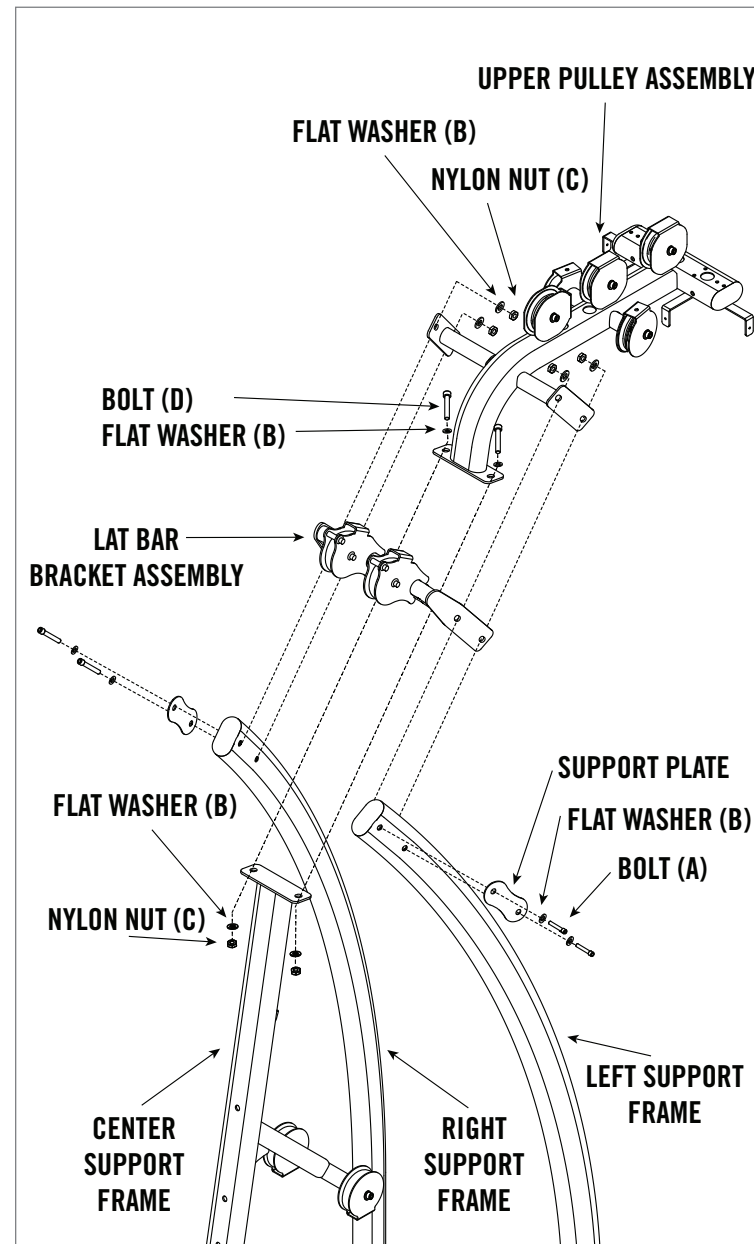
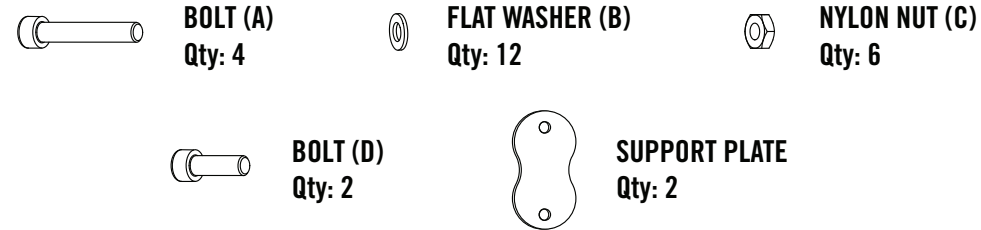

- A** Open **HARDWARE BAG 1**.
- B** Attach **UPPER PULLEY ASSEMBLY** to **CENTER SUPPORT FRAME** using 2 **BOLTS (D)**, 4 **FLAT WASHERS (B)** and 2 **NYLON NUTS (C)**. Tighten this hardware.
- C** Position **LAT BAR BRACKET ASSEMBLY** in line with the **UPPER PULLEY ASSEMBLY** and the **LEFT SUPPORT FRAME** and **RIGHT SUPPORT FRAME** as shown. Using 4 **BOLTS (A)**, 8 **FLAT WASHERS (B)** and 4 **NYLON NUTS (C)** attach **SUPPORT PLATES**, **LAT BAR BRACKET ASSEMBLY** and **UPPER PULLEY ASSEMBLY** to the **LEFT SUPPORT FRAME** and **RIGHT SUPPORT FRAME** as shown.

ASSEMBLY STEP 3

HARDWARE BAG 2 CONTENTS :

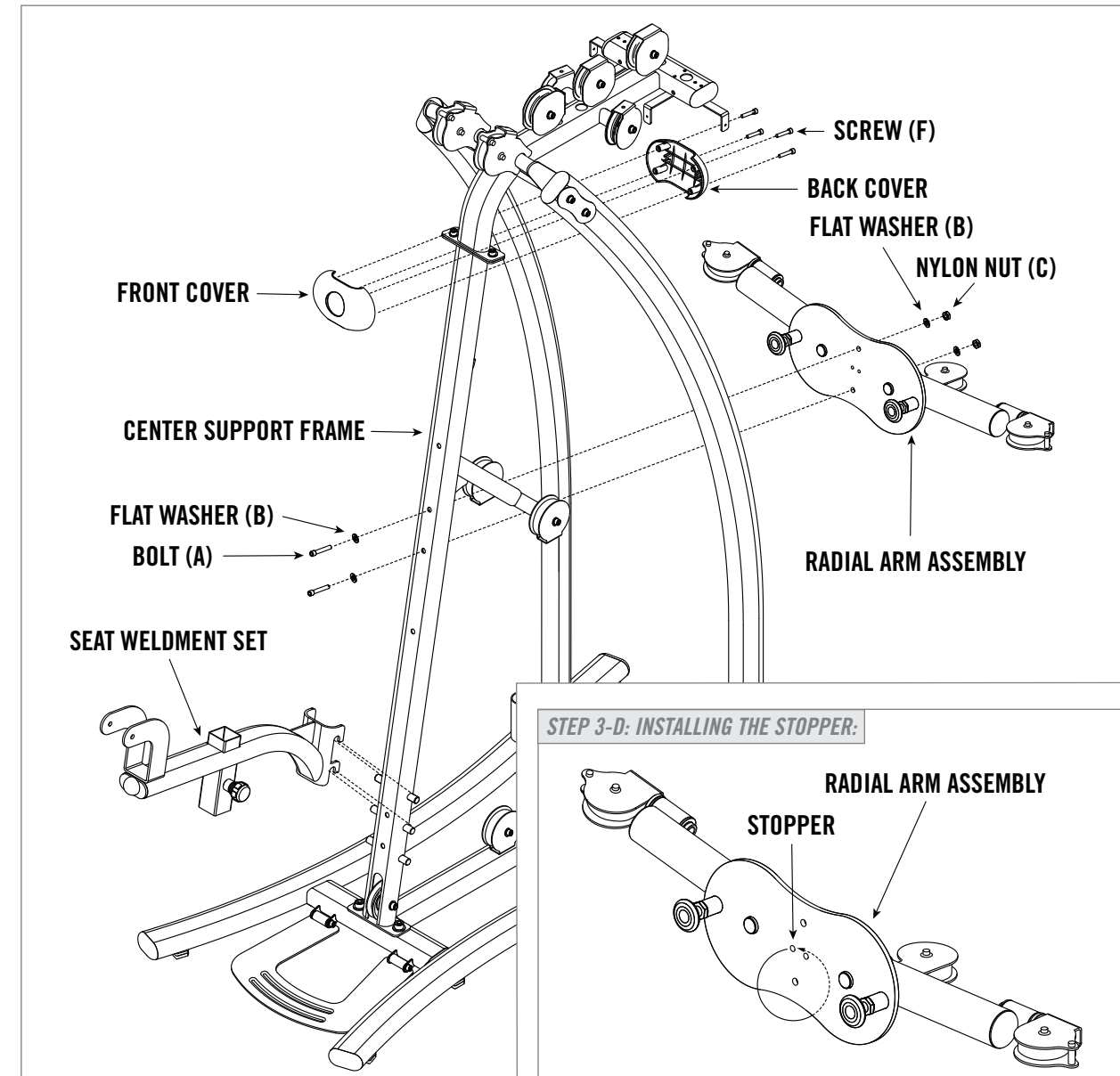
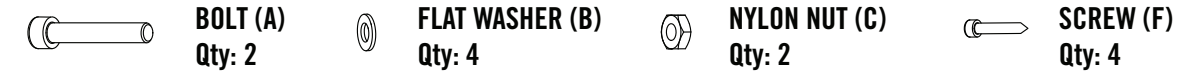

- A** Open **HARDWARE BAG 2**.
- B** Attach **SEAT WELDMENT SET**.
- C** Attach **COVER** to bolted joint using 4 **SCREWS (F)**.
- D** Remove **STOPPER** from front side of **RADIAL ARM ASSEMBLY** and reinstall on back side of **RADIAL ARM ASSEMBLY**.
- E** Attach **RADIAL ARM ASSEMBLY** to **CENTER SUPPORT FRAME** using 2 **BOLTS (A)**, 4 **FLAT WASHERS (B)** and 2 **NYLON NUTS (C)**.

ASSEMBLY STEP 4

HARDWARE BAG 3 CONTENTS :

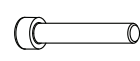
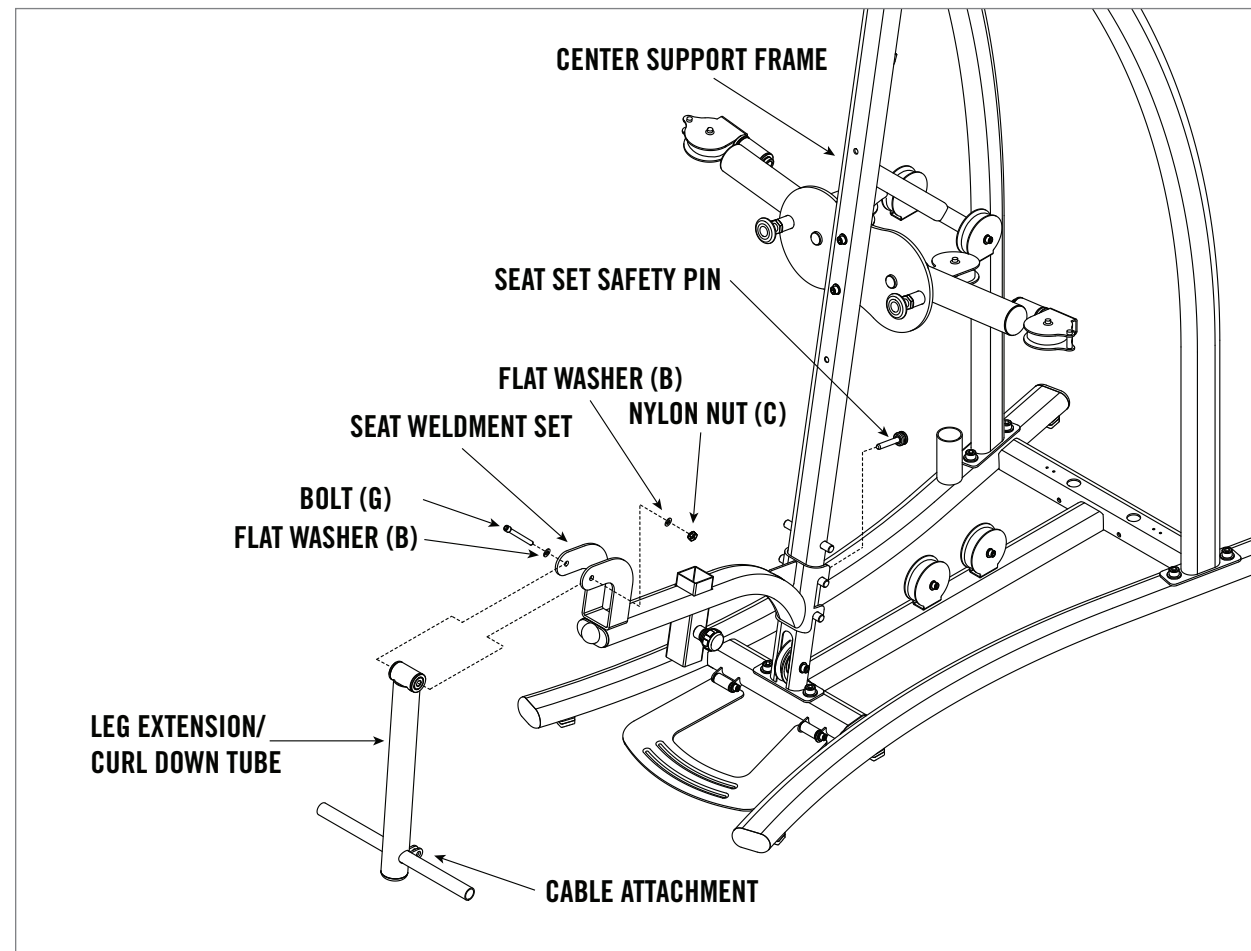
FLAT WASHER (B)
Qty: 2NYLON NUT (C)
Qty: 1BOLT (G)
Qty: 1

A Open **HARDWARE BAG 3**.

B Attach **LEG EXTENSION/CURL DOWN TUBE** to **SEAT ASSEMBLY** using 1 **BOLT (G)**, 2 **FLAT WASHERS (B)** and 1 **NYLON NUT (C)**.

NOTE: Position the **LEG EXTENSION/CURL DOWN TUBE** so the cable attachment is facing the gym.

C Insert **SEAT SET SAFETY PIN**.

ASSEMBLY STEP 5

HARDWARE BAG 4 CONTENTS :

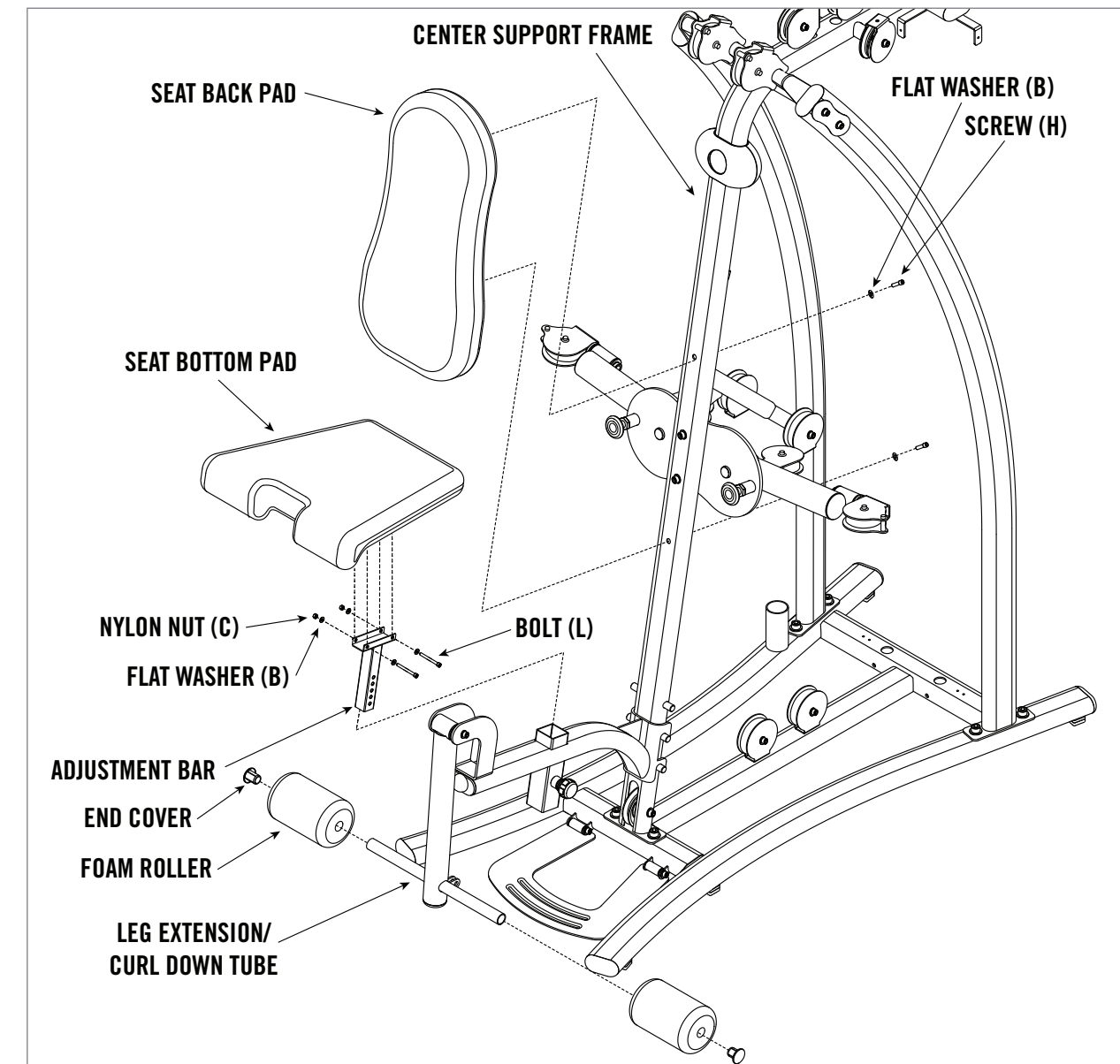
FLAT WASHER (B)
Qty: 6NYLON NUT (C)
Qty: 2BOLT (H)
Qty: 2BOLT (L)
Qty: 2

A Open **HARDWARE BAG 4**.

B Attach **SEAT BACK PAD** to **CENTER SUPPORT FRAME** using 2 **SCREWS (H)**, 2 **FLAT WASHERS (B)**.

C Attach **SEAT BOTTOM PAD** to **SEAT WELDMENT** using 2 **BOLTS (D)**, 4 **FLAT WASHERS (B)** and 2 **NYLON NUTS (C)**.

D Install assembled seat into gym.

E Install **LEG PADS** to **LEG EXTENSION/CURL DOWN TUBE** as shown in diagram.

ASSEMBLY STEP 6

HARDWARE BAG 5 CONTENTS :

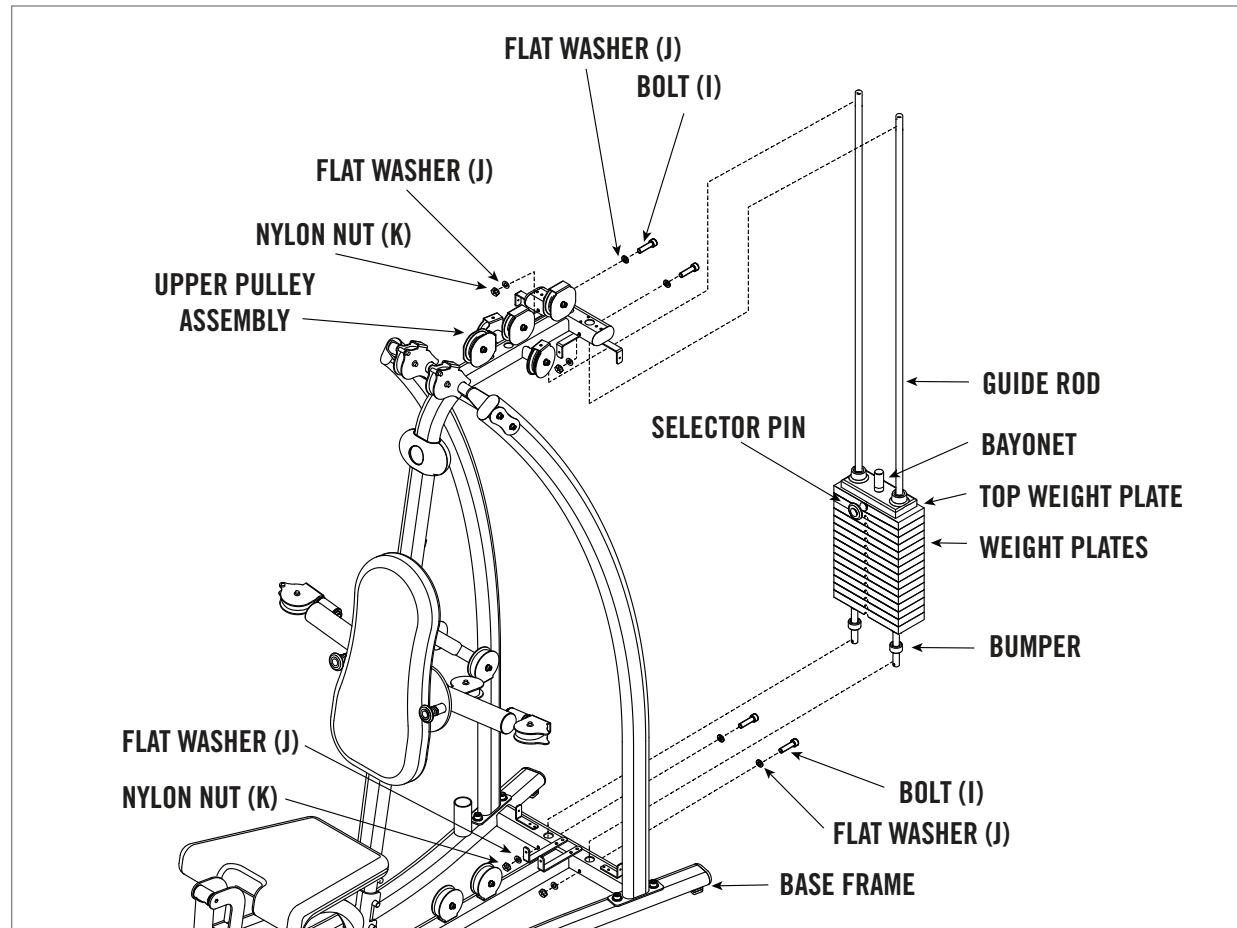
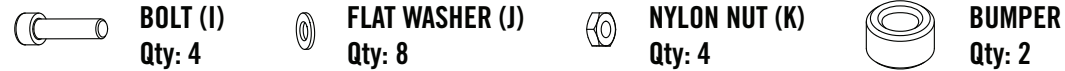

- A** Open **HARDWARE BAG 5**.
- B** Install 2 **BOLTS (I)**, 4 **FLAT WASHERS (J)** and 2 **NYLON NUTS (K)** into the **BASE FRAME** as shown in diagram.
- C** Insert each **GUIDE ROD** into the **BASE FRAME** as shown in diagram.
- D** Install rubber **BUMPER** onto each **GUIDE ROD**.
- E** Install each **WEIGHT PLATE** onto **GUIDE RODS**
NOTE: Ensure that each **WEIGHT PLATE**'s selector pin slot faces downward.
- F** Insert each **GUIDE ROD** into the corresponding hole in the **UPPER PULLEY ASSEMBLY**.
- G** Secure **GUIDE RODS** in **UPPER PULLEY ASSEMBLY** using 2 **BOLTS (I)**, 4 **FLAT WASHERS (J)** and 2 **NYLON NUTS (K)**.
NOTE: Ensure that each bolt is inserted through the hole at the top of the **GUIDE ROD**.
- H** Tighten all hardware.

ASSEMBLY STEP 7

HARDWARE BAG 6 CONTENTS :

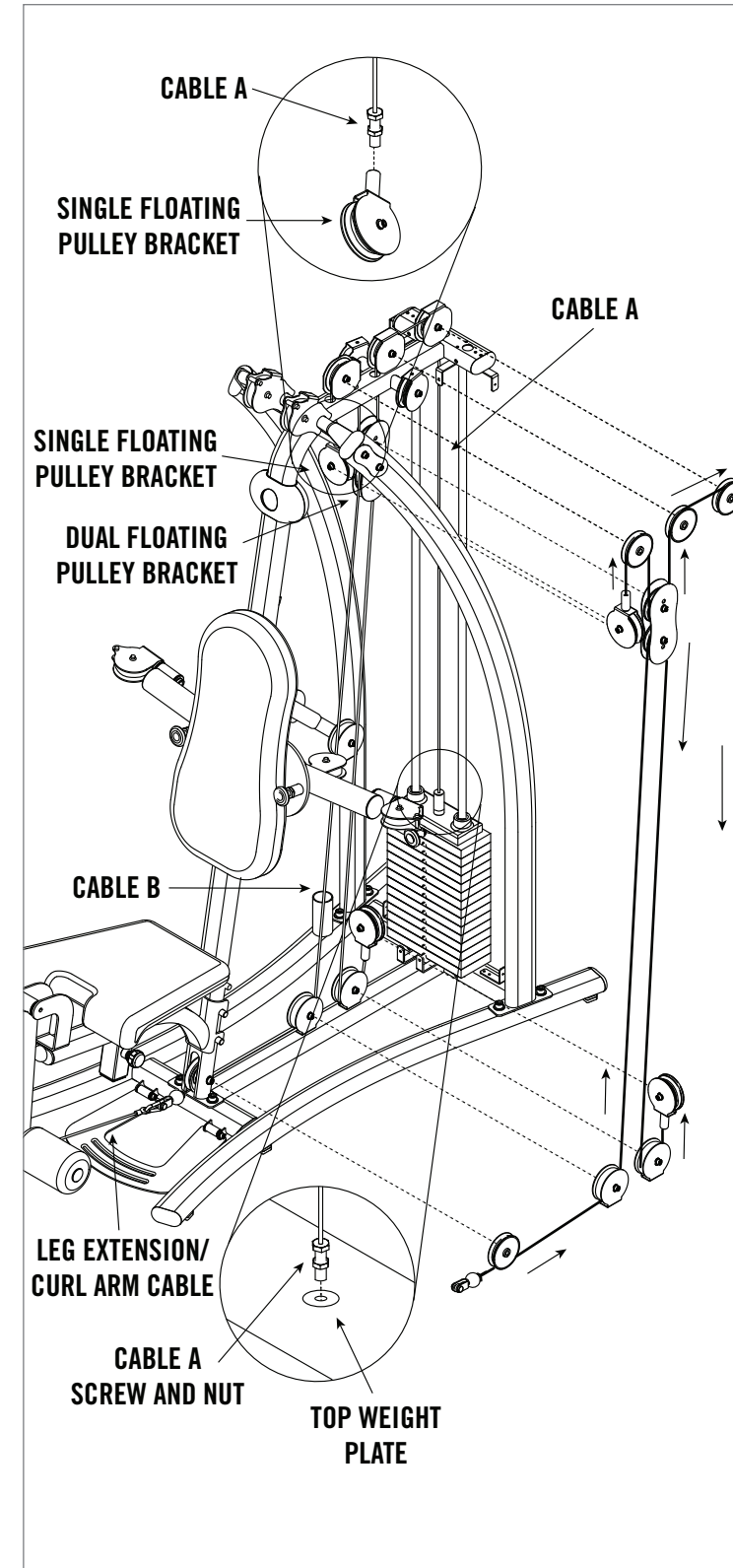

- A** Open **HARDWARE BAG 6**.
- B** Remove nylon nut and threaded screw from end of **CABLE A**.
- C** Insert cable end into **LAT BAR BRACKET ASSEMBLY** pulley as shown in diagram.
NOTE: After passing through first pulley bracket, thread cable through **DUAL FLOATING PULLEY BRACKET** then thread back into **LAT BAR BRACKET ASSEMBLY**.
- D** Re-install threaded screw and nylon nut before threading cable into **TOP WEIGHT PLATE**.
NOTE: Always maintain at least $\frac{1}{2}$ " of weight cable screw in **TOP WEIGHT PLATE** for safety.
- E** Screw the other end of **CABLE A** into **SINGLE FLOATING PULLEY**.
- F** Remove nylon nut and threaded screw from end of **CABLE B**.
- G** Insert cable end into **BASE FRAME** pulleys as shown in diagram.
NOTE: After passing through first pulley bracket, thread cable through **DUAL FLOATING PULLEY BRACKET**.
- H** After **CABLE B** routing is complete replace threaded end and nut onto cable end, and install **SINGLE FLOATING PULLEY**.
- I** Attach **CABLE B** to **LEG EXTENSION/CURL ARM CABLE**.

ASSEMBLY STEP 8

HARDWARE BAG 7 CONTENTS :

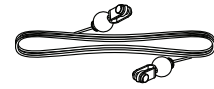
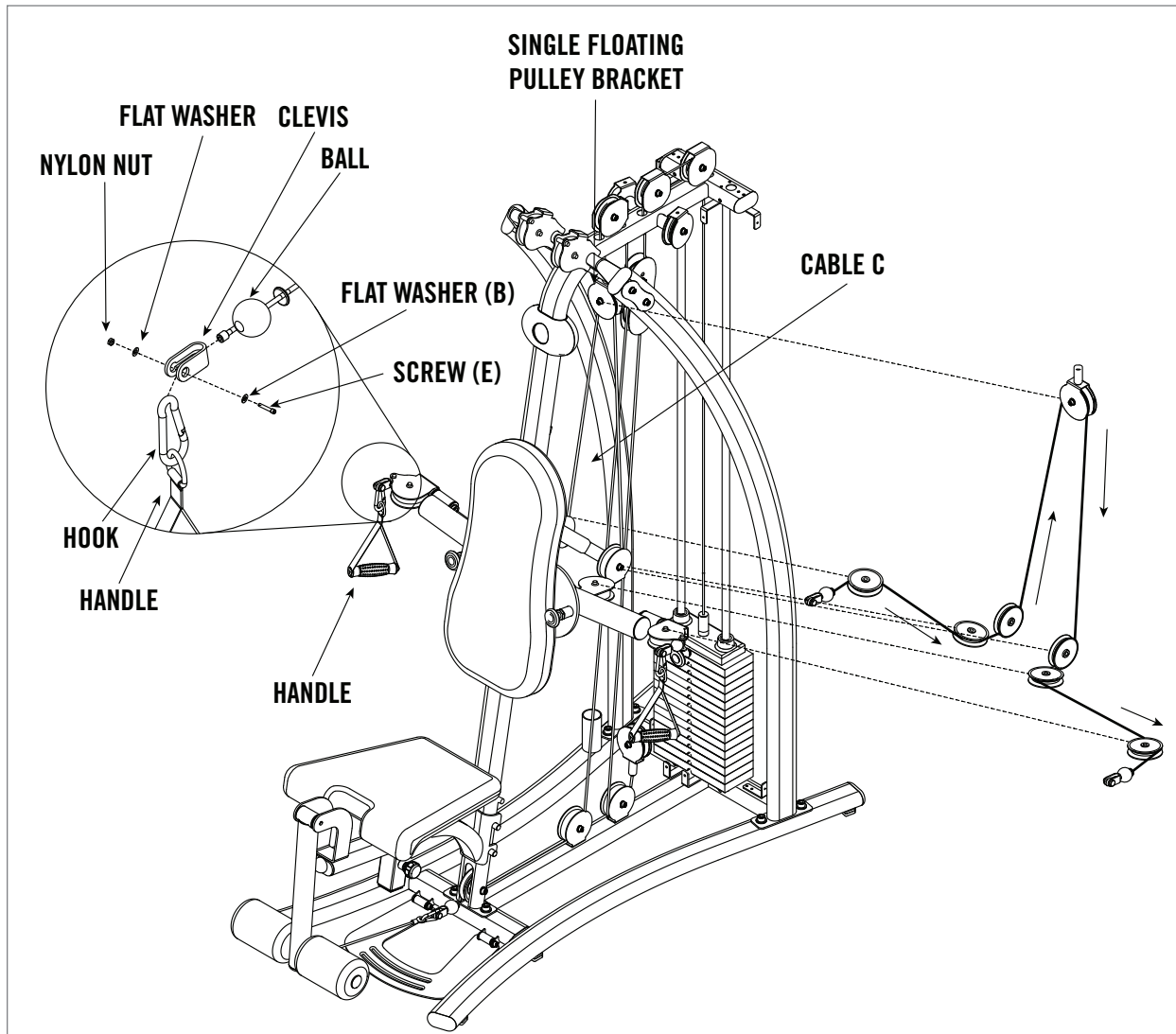
CABLE C
Qty: 1

- A** Open **HARDWARE BAG 7**.
- B** Remove **NYLON NUT**, **FLAT WASHER**, **THREADED SCREW** and **BALL** from end of **CABLE C**.
- C** Route **CABLE C** through the pulley system in the **RADIAL ARM ASSEMBLY** as shown in diagram.
NOTE: After threading through one arm of **RADIAL ARM ASSEMBLY** thread **CABLE C** up through **SINGLE FLOATING PULLEY BRACKET** before bringing to back through other arm.
- D** After **CABLE C** routing is complete replace nylon nut, threaded screw and ball on end of cable.
- E** Hook **HANDLES** on to cable using the 2 **HOOKS**.

ASSEMBLY STEP 9

HARDWARE BAG 8 CONTENTS :

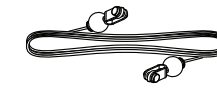
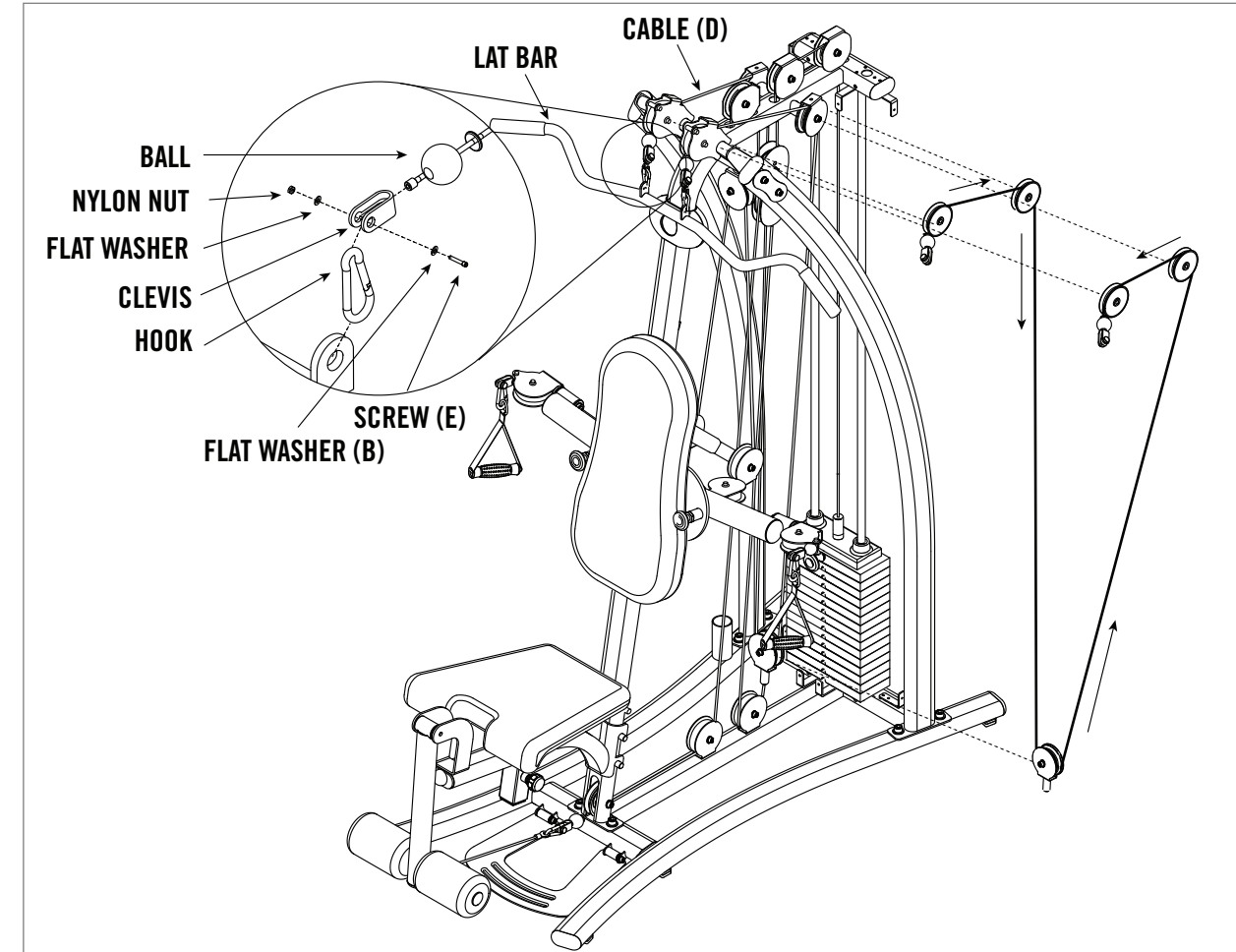
CABLE D
Qty: 1

- A** Open **HARDWARE BAG 8**.
- B** Remove nylon nut, threaded screw and ball from end of **CABLE D**.
- C** Route **CABLE D** through the pulley system in the **UPPER PULLEY BRACKET ASSEMBLY** as shown in diagram.
- D** After **CABLE D** routing is complete replace nylon nut, threaded screw and ball on end of cable.

ASSEMBLY STEP 10

HARDWARE BAG 9 CONTENTS :

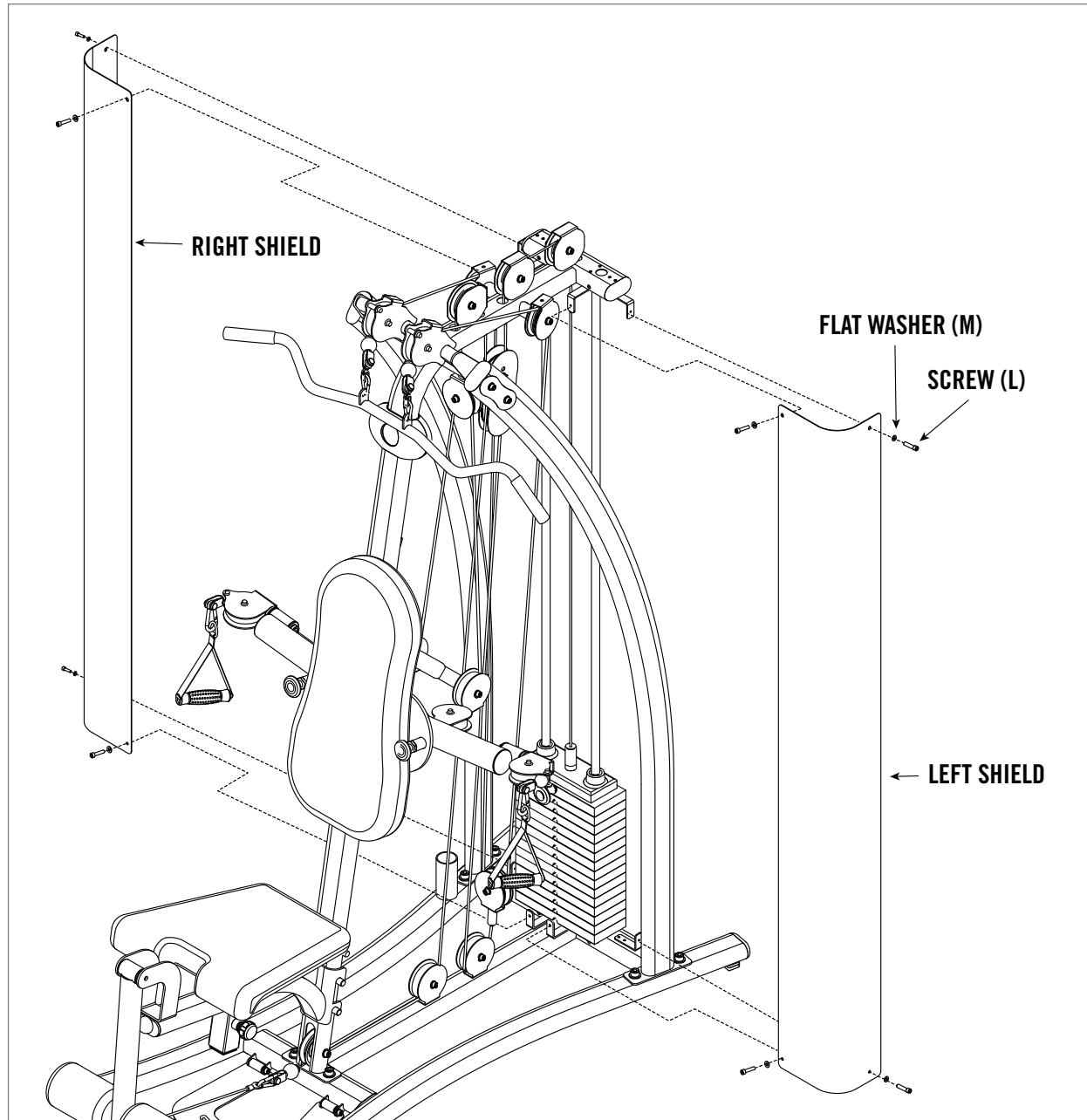
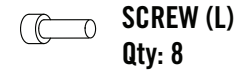

- A** Open **HARDWARE BAG 9**.
- B** Install **WEIGHT SHIELD** as shown in diagram, using 8 **SCREWS (L)** and 8 **FLAT WASHERS (M)**.

YOU'RE FINISHED!

BEFORE YOU BEGIN

CONGRATULATIONS! on choosing your home gym. You've taken an important step in developing and sustaining an exercise program! Your home gym is a tremendously effective tool for achieving your personal fitness goals. Regular use of your home gym can improve the quality of your life in so many ways.

HERE ARE JUST A FEW OF THE HEALTH BENEFITS OF EXERCISE:

- Improved Muscle Tone and Strength
- Increased Daily Energy Levels
- A Healthier Heart
- Weight Loss

The key to reaping these benefits is to develop an exercise habit. Your new home gym will help you eliminate obstacles that prevent you from exercising. Inclement weather and darkness won't interfere with your workout when you use your home gym in the comfort of your home. This guide provides you with basic information for using and enjoying your new machine.

LOCATION OF THE HOME GYM

Place the home gym on a level surface. There should be 1 foot of clearance behind the home gym, 3 feet on each side and 3 feet in front. Do not place the home gym in any area that will block any vent or air openings. The home gym should not be located outdoors.

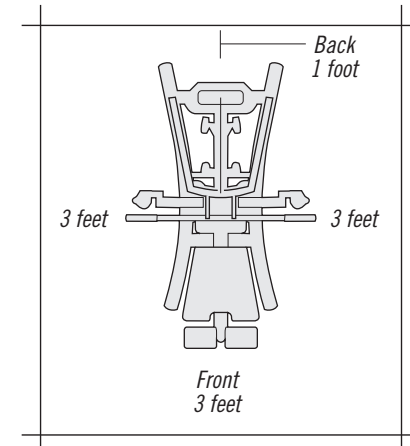

SEAT ASSEMBLY PIN

Ensure that the seat assembly safety pin is fully inserted before using the home gym. Failure to do so may result in injury!

PROPER USAGE

Make sure to follow the MAINTENANCE schedule in this manual. Stop your workout immediately if you feel pain, faint, dizzy or are short of breath.



Do not operate the home gym if there is any noticeable damage to the cables or pulleys. If any damage is noticeable, contact customer tech support at the number located on the back panel of this manual.

CONDITIONING GUIDELINES

ALWAYS CONSULT YOUR PHYSICIAN BEFORE BEGINNING AN EXERCISE PROGRAM.

HOW OFTEN? (Frequency of Workouts)

The American Heart Association recommends that you exercise at least 3 to 4 days per week to maintain fitness. If you have other goals such as weight or fat loss, you will achieve your goal faster with more frequent exercise. Whether it's 3 days or 6 days, remember that your ultimate goal should be to make exercise a lifetime habit. Many people are successful staying with a fitness program if they set aside a specific time of day to exercise. It doesn't matter whether it's in the morning before breakfast, during lunch hour or while watching the evening news. What's more important is that it's a time that allows you to keep a schedule, and a time when you won't be interrupted. To be successful with your fitness program, you have to make it a priority in your life. So decide on a time, pull out your day planner and pencil in your exercise times for the next month!

HOW LONG? (Duration of Workouts)

For aerobic exercise benefits, it's recommended that you exercise from between 24 and 60 minutes per session. But start slowly and gradually increase your exercise times. If you've been sedentary during the past year, it may be a good idea to keep your exercise times to as little as 5 minutes initially. Your body will need time to adjust to the new activity. If your goal is weight loss, a longer exercise session at lower intensities has been found to be most effective.

HOW HARD? (Intensity of Workouts)

How hard you workout is also determined by your goals. If you use your home gym to prepare for a 5K run, you will probably work out at a higher intensity than if your goal is general fitness. Regardless of your long term goals, always begin an exercise program at low intensity. Aerobic exercise does not have to be painful to be beneficial! There are two ways to measure your exercise intensity. The first is by monitoring your heart rate (using the grip pulse handlebars or a wireless chest transmitter - may be sold separately), and the second is by evaluating your perceived exertion level (this is simpler than it sounds!).

PERCEIVED EXERTION LEVEL

A simple way to gauge your exercise intensity is to evaluate your perceived exertion level. While exercising, if you are too winded to maintain a conversation without gasping, you are working out too hard. A good rule of thumb is to work to the point of exhilaration, not exhaustion. If you cannot catch your breath, it's time to slow down. Always be aware of these warning signs of overexertion.

GENERAL STRENGTH TRAINING GUIDELINES

- It is recommended that you perform at least 5-10 minutes of cardiovascular exercise before beginning your strength routine in order to warm the muscles, increase the heart rate, and prepare your body for strength training.
- Always raise and lower the weight in a smooth, slow, and controlled motion.
- Try not to hold your breath during strength training exercises. It is recommended that you exhale as you raise the weight and inhale as you lower the weight.
- It is recommended that each muscle group be allowed to rest 48 hours between strength training.
- Complete each strength routine with a few simple stretches to maintain flexibility, and allow your body to cool-down after your session.

TARGET HEART RATE ZONE CHART

What is Target Heart Rate Zone?

Target Heart Rate Zone tells you the number of times per minute your heart needs to beat to achieve a desired workout effect. It is represented as a percentage of the maximum number of times your heart can beat per minute. Target Zone will vary for each individual, depending on age, current level of conditioning, and personal fitness goals. The American Heart Association recommends working-out at a Target Heart Rate Zone of between 60% and 75% of your maximum heart rate. A beginner will want to workout in the 60% range while a more experienced exerciser will want to workout in the 70-75% range. See chart for reference.

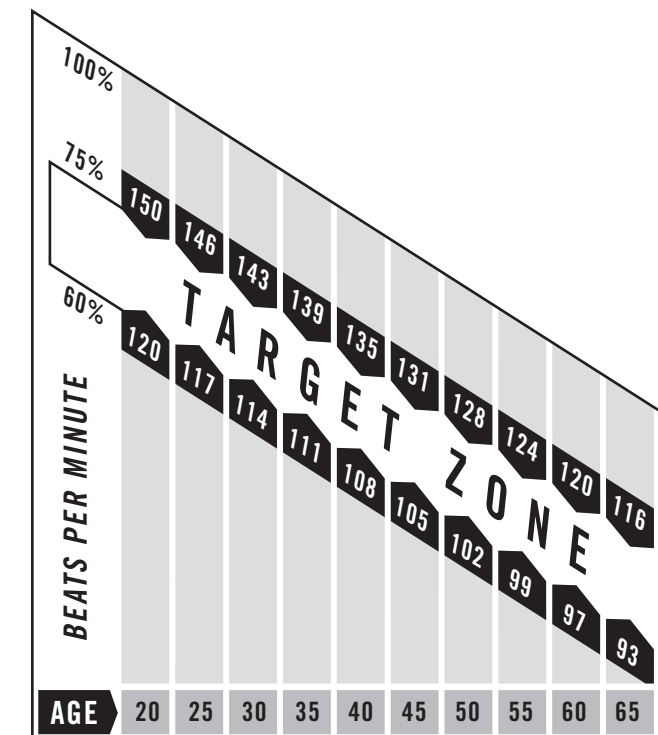

EXAMPLE:

For a 42-year-old user: Find age along the bottom of the chart (round to 40), follow age column up to the target zone bar. Results: 60% of maximum Heart Rate = 108 Beats Per Minute, 75% of maximum Heart Rate = 135 Beat Per Minute.

ALWAYS CONSULT YOUR PHYSICIAN BEFORE BEGINNING AN EXERCISE PROGRAM.

TIPS



STRETCHING

STRETCH FIRST

Before using your product, it is best to take a few minutes doing a few gentle stretching exercises. Stretching prior to exercise will improve flexibility and reduce chances of exercise related injury. Ease into each of these stretches with a slow gentle motion. Do not stretch to the point of pain. Make sure not to bounce while doing these stretches.

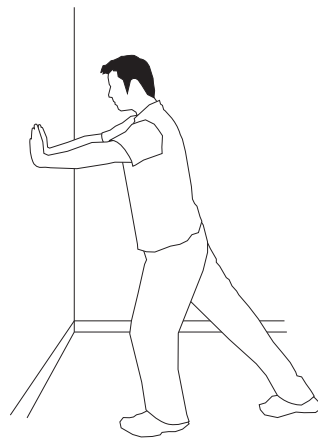
**1. STANDING CALF MUSCLE STRETCH**

Stand near a wall with the toes of your left foot about 18" from the wall, and the right foot about 12" behind the other foot. Lean forward, pushing against the wall with your palms. Keep your heels flat and hold this position for a count of 15 seconds. Make sure that you do not bounce while stretching. Repeat on the other side.

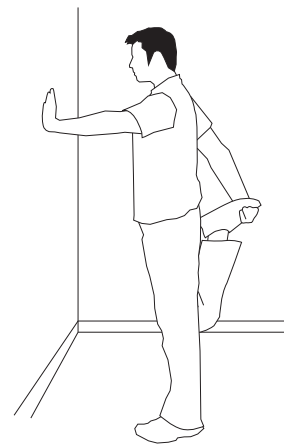
**2. STANDING QUADRICEPS STRETCH**

Using a wall to provide balance, grasp your left ankle with your left hand and hold your foot against the back of your thigh for 15 seconds. Repeat with your right ankle and hand.

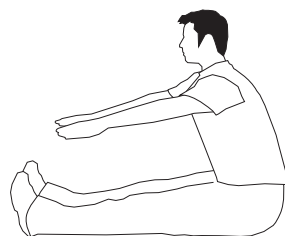
**3. SITTING HAMSTRING & LOWER BACK MUSCLE STRETCH**

Sit on the floor with your legs together and straight out in front of you. Do not lock your knees. Extend your fingers towards your toes and hold for a count of 15 seconds. Make sure that you do not bounce while stretching. Sit upright again. Repeat one time.

TIPS



THE IMPORTANCE OF WARM UP & COOL DOWN

WARM UP

Always perform 10-15 minutes of aerobic activity before beginning your strength training session. This warm-up will limber your muscles and prepare them for more strenuous exercise. Make sure that you warm-up on your product at a slow pace. The warm up should gradually increase your heart rate into your heart rate training zone and increase core body temperature.

COOL DOWN

Never stop exercising suddenly! A cool-down period of 3-5 minutes allows your heart to readjust to the decreased demand. Your cool-down period should consist of repeating the stretching exercises listed above to loosen and relax your muscles.

TIPS



ACHIEVING YOUR FITNESS GOALS

An important step in developing a long term fitness program is to determine your goals. Is your primary goal for exercising to lose weight? Improve muscle tone and/or strength? Reduce stress? Knowing what your goals are will help you develop a more successful exercise program. Below are some common exercise goals:

- Weight Loss - lower intensity, longer duration workouts
- Improve Body Shape and Tone - interval workouts, alternate between hi and low intensities
- Increased Energy Level - more frequent daily workouts
- Improved Sports Performance - high intensity workouts

If possible try to define your personal goals in precise, measurable terms, and then put your goals in writing. The more specific you can be, the easier it will be to track your progress. If your goals are long term, divide them up into monthly and weekly segments. Longer term goals can lose some of the immediate motivation benefits. Short term goals are easier to achieve.

DAILY LOG SHEETS

DATE _____	SET 1		SET 2		SET 3	
EXERCISE	WEIGHT	REPS	WEIGHT	REPS	WEIGHT	REPS

DATE _____	SET 1		SET 2		SET 3	
EXERCISE	WEIGHT	REPS	WEIGHT	REPS	WEIGHT	REPS

DATE _____	SET 1		SET 2		SET 3	
EXERCISE	WEIGHT	REPS	WEIGHT	REPS	WEIGHT	REPS

DATE _____	SET 1		SET 2		SET 3	
EXERCISE	WEIGHT	REPS	WEIGHT	REPS	WEIGHT	REPS

DATE _____	SET 1		SET 2		SET 3	
EXERCISE	WEIGHT	REPS	WEIGHT	REPS	WEIGHT	REPS

DATE _____	SET 1		SET 2		SET 3	
EXERCISE	WEIGHT	REPS	WEIGHT	REPS	WEIGHT	REPS

TROUBLESHOOTING

Your home gym is designed to be reliable and easy to use. However, if you experience a problem, please reference the troubleshooting guide listed below.

PROBLEM: The cables feel rough and are noisy during use.

SOLUTION: Verify the following:

IS THERE ANY NOTICABLE DAMAGE TO THE CABLES?

IF YES:

- Contact customer tech support and replace the cable(s).

IF NO:

- Verify that all cables are secured into the pulleys.
- Verify that the weight stack guiderods are lubricated with a spray or silicone gel lubricant.
- Verify that there is no excessive slack in the cables.

NOTE: If there is excessive slack adjust cable tension (see next page).

PROBLEM: Weight selector pin cannot be inserted.

SOLUTION: Verify the following:

ARE THE HOLES ALLIGNED THROUGH THE WEIGHT PLATE AND BAYONETTE?

IF YES:

- Verify that the selector pin isn't bent or damaged.

IF NO:

- Adjust threaded bolt on top plate so that the holes in the bayonette align with the weight plate.

NOTE: Always maintain at least ½" of threaded bolt in bayonette.

If the above troubleshooting section does not remedy the problem, discontinue use.

PLEASE CALL CUSTOMER TECH SUPPORT AT THE NUMBER ON THE BACK PANEL.

The following information may be asked of you when you call. Please have these items readily available:

- Model Name
- Serial Number
- Date of Purchase (receipt or credit card statement)

In order for a technician to service your home gym they may need to ask detailed questions about the symptoms that are occurring.

Some troubleshooting questions that may be asked are:

- How long has this problem been occurring?
- Does this problem occur with every use? With every user?
- If you are hearing a noise, does it come from the front or the back? What kind of noise is it (thumping, grinding, squeaking, chirping etc.)?
- Has the machine been lubricated and maintained per the maintenance schedule?

Answering these and other questions will give the technicians the ability to send proper replacement parts and the service necessary to get you and your Horizon Fitness home gym functioning again!

MAINTENANCE

Cleanliness of your home gym and its operation environment will keep maintenance problems and service calls to a minimum. For this reason, we recommend that the following preventive maintenance schedule be followed.

AFTER EACH USE (DAILY)

- Wipe upholstery, handgrips, bars, and frame (if needed) with a soap and water cleaning solution.

EVERY WEEK

- Lubricate guide rods with a spray or silicone gel lubricant.
- Inspect cable ends and cable insulation for damage.

EVERY MONTH - IMPORTANT!

- Inspect all frame bolts and tighten as needed.

ADJUSTING CABLE TENSION

Regularly check the cable tension of your home gym. If excessive slack exists adjust cable tension by removing the pulley bolts and moving one or both pulleys to the inner mounting position in the dual floating pulley bracket and then reinstalling the pulley bolts. Cable tension may also be adjusted using the threaded cable end on single pulley bracket and weight stack Twist threaded end to adjust tension and then tighten lock nut.

NOTE: Always maintain at least ½" of threaded bolt in bayonet.

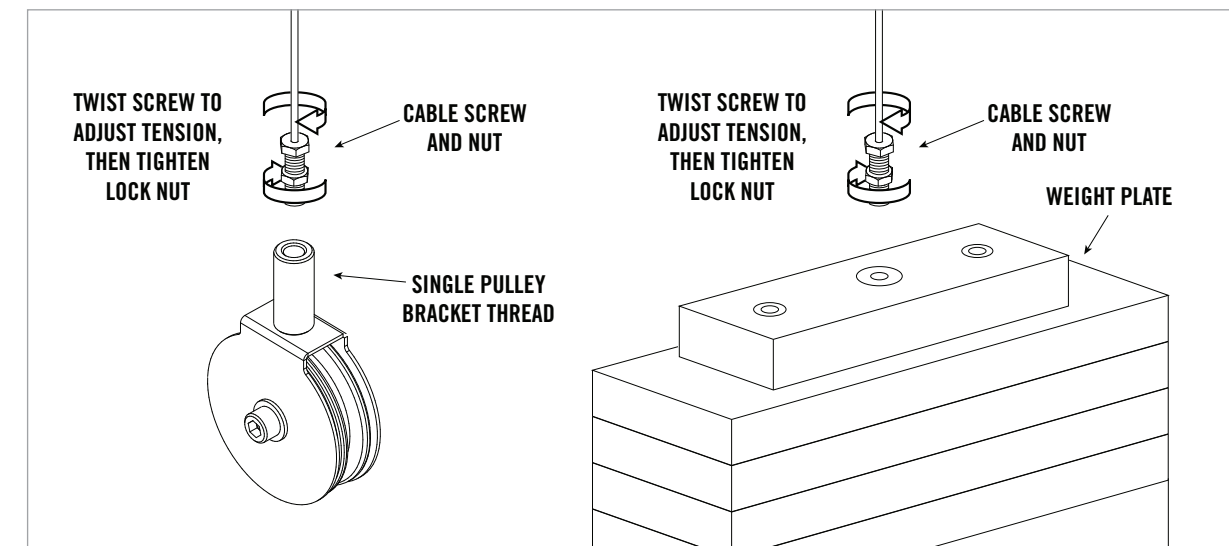
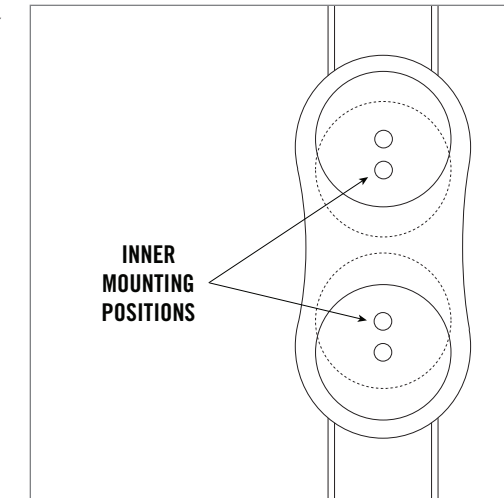

LIMITED HOME-USE WARRANTY (U.S. MODELS ONLY)

FRAME • LIFETIME

Horizon Fitness warrants the frame against defects in workmanship and materials for the lifetime of the original owner. (The frame is defined as the welded metal base of the unit and does not include any parts that can be removed.)

WEIGHT CAPACITY = 300 LBS

PARTS • 5 YEARS

Horizon Fitness warrants all original parts for a period of five years from the date of original purchase, so long as the device remains in the possession of the original owner.

LABOR • 1 YEAR

Horizon Fitness shall cover the labor cost for the repair of the device for a period of one year from the date of the original purchase, so long as the device remains in the possession of the original owner.

UPHOLSTERY • 90 DAYS

Horizon Fitness warrants the upholstery for a period of 90 days from the date of original purchase, so long as the device remains in the possession of the original owner.

EXCLUSIONS AND LIMITATIONS

Who IS covered:

- The original owner and is not transferable.

What IS covered:

- Repair or replacement of a defective motor, electronic component, or defective part and is the sole remedy of the warranty.

What IS NOT covered:

- Normal wear and tear, improper assembly or maintenance, or installation of parts or accessories not originally intended or compatible with the equipment as sold.
- Damage or failure due to accident, abuse, corrosion, discoloration of paint or plastic, neglect, theft, vandalism, fire, flood, wind, lightning, freezing, or other natural disasters of any kind, power reduction, fluctuation or failure from whatever cause, unusual atmospheric conditions, collision, introduction of foreign objects into the covered unit, or modifications that are unauthorized or not recommended by Horizon Fitness.
- Incidental or consequential damages. Horizon Fitness is not responsible or liable for indirect, special or consequential damages, economic loss, loss of property, or profits, loss of enjoyment or use, or other consequential damages of whatsoever nature in connection with the purchase, use, repair or maintenance of the equipment.
- Equipment used for commercial purposes or any use other than a single family or Household, unless endorsed by Horizon Fitness for coverage.
- Equipment owned or operated outside the US and Canada.
- Delivery, assembly, installation, setup for original or replacement units or labor or other costs associated with removal or replacement of the covered unit.
- Any attempt to repair this equipment creates a risk of injury. Horizon Fitness is not responsible or liable for any damage, loss or liability arising from any personal injury incurred during the course of, or as a result of any repair or attempted repair of your fitness equipment by other than an authorized service technician. All repairs attempted by you on your fitness equipment are undertaken AT YOUR OWN RISK and Horizon Fitness shall have no liability for any injury to the person or property arising from such repairs.

SERVICE/RETURNS

- In-home service is available within 150 miles of the nearest authorized repair center (Mileage beyond 150 miles from an authorized service center is the responsibility of the consumer).
- All returns must be pre-authorized by Horizon Fitness.
- Horizon Fitness' obligation under this warranty is limited to replacing or repairing, at Horizon Fitness' option, the same or comparable model at one of its authorized service centers.
- A Horizon Fitness authorized service center must receive all equipment for which a warranty claim is made. This equipment must be received with all freight and other transportation charges prepaid, accompanied by sufficient proof of purchase.
- Replacement units, parts reconditioned to As-new Condition by Horizon Fitness or its vendors may sometimes be supplied as warranty replacement and constitute fulfillment of warranty terms.
- This warranty gives you specific legal rights, and your rights may vary from state to state.

CUSTOMER TECH SUPPORT

For fast and friendly service, please contact one of our trained customer technicians via phone, email or our website.

Customer Tech Support Hotline: 1-800-244-4192

Email: comments@horizonfitness.com

Website: www.horizonfitness.com

Every employee at Horizon Fitness takes pride in providing you with a high quality product. We want to know if you have a problem and we want to have an opportunity to correct it for you.

NOTE: *Please read the TROUBLESHOOTING section before contacting Customer Tech Support. To receive additional product information, visit us at www.horizonfitness.com*



HORIZON
FITNESS

1620 Landmark Drive,
Cottage Grove WI, 53527
Tel: 1.800.244.4192
Fax: 608.839.1260