

## INSTRUCTION MANUAL

# PYTHON

2-CHANNEL DIGITAL PROPORTIONAL RADIO CONTROL SYSTEM

**JR**

### I. INTRODUCTION

Congratulations on your purchase of the JR Python 2-channel radio control set which has been manufactured and assembled with the greatest care.

We are confident that you will be delighted with your purchase. Please read the instructions thoroughly, noting all points before use, in order to avoid mistakes in handling and operation.

### II. COMPONENTS AND SPECIFICATIONS

Your JR Python Radio includes the following items:

Transmitter ..... NET-112L  
2-Channel Receiver ..... NER-102  
2 Servos ..... Z250 x 2  
Accessories ..... B.E.C. Switch Harness and Servo Accessories

#### TRANSMITTER SPECIFICATIONS: PYTHON LED

Antenna Output ..... 500mW  
Frequency ..... 27/75 MHz  
Modulation ..... AM  
Power Supply ..... 9.6V D/C  
Dimensions ..... 8.15" x 7.00" x 3.35"  
Weight ..... 13 oz

#### RECEIVER SPECIFICATIONS: R102

Intermediate Frequency ..... 455KHz  
Power Supply ..... 4.8V-8.4V D/C  
Dimensions ..... 1.93" x 1.50" x 0.827"  
Weight ..... 1.3 oz

#### SERVO SPECIFICATIONS: Z250

Torque ..... 49 in/oz. (6V)  
Speed ..... .19 sec/60° (6V)  
Dimensions ..... 0.73" x 1.52" x 1.32"  
Weight ..... 1.5 oz  
BB ..... Bushing  
Motor ..... 3-Pole Ferrite

### III. R/C SAFETY PRECAUTIONS

For safe and reliable performance of your R/C model, please carefully read and follow these guidelines:

1. Radio control models are not toys. They are capable of inflicting serious injury to people and property. Use caution at all times when operating your model.
2. You are responsible for the safe operation of your R/C model. You must properly install, test, and operate your model with a clear sense of that responsibility. Do not take risks that might endanger yourself or others.
3. Running an R/C car in the streets is very dangerous to both drivers and models. Avoid running your model in areas occupied by full-size automobiles. To locate areas where you can safely operate your model, contact your local hobby shop for R/C tracks or clubs in your area.
4. When running an R/C boat, keep it away from any swimmers, full-size boats, or wildlife. Also, watch carefully for fishing lines that can entangle the propeller.

5. Before operating your model, make sure your frequency is clear. If someone else is operating on the same frequency, both models will go out of control, possibly causing damage to the models, as well as others.
6. If at any time while operating your R/C model you sense abnormal model functioning, end your operation immediately. Do not operate your model again until you are certain the problem has been corrected.

**CAUTION:** Control of your model is impossible without sufficient voltage for the transmitter and receiver. A weak transmitter battery will decrease your range of operation and a weak receiver battery will slow servo movement and decrease your range of operation. Check your receiver pack voltage often to avoid losing control of your model. When using a model that operates both the electric motor and the receiver from the same battery (Battery Eliminating Circuitry or B.E.C.), you should discontinue use when the top speed sharply decreases or you will quickly lose control of your model.

## IV. OPERATING YOUR MODEL

It is important to learn the proper sequence for switching ON/OFF your radio system:

BEFORE OPERATION: Switch on the transmitter, then the receiver.  
 AFTER OPERATION: Switch off the receiver, then the transmitter.

This ensures that you will always have a signal to the receiver, and your R/C model will not operate out of control when you turn off the transmitter.

## V. INSTALLATION

### JR PYTHON WITH Z250 SERVOS SERVO FEATURES

- A tight deadband amplifier ensures accurate neutral centering
- Low current drain
- An indirect drive feedback potentiometer gives additional protection from vibration
- State-of-the-art surface mount technology (SMT)
- 3-pole ferrite cored motor for reliability

### Z250 SERVO LAYOUT

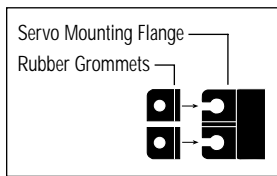
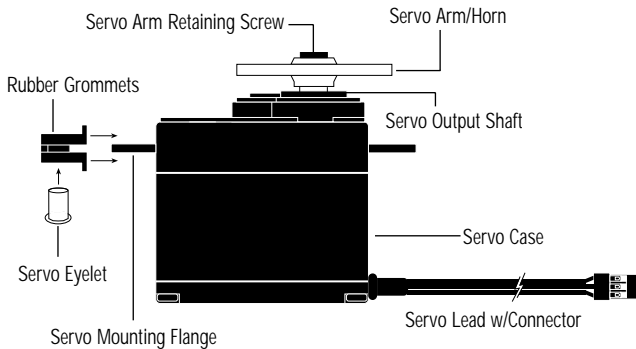

TOP VIEW

Your NER-102 Receiver has Battery Eliminator Circuitry (B.E.C.). The receiver gets its power from the model's NiCad battery pack, thus saving the weight of an additional receiver battery. NiCad batteries from 6V-8.4V (5-7 cells) can be used safely. Higher voltage packs may damage the receiver and servos.

**ATTENTION:** Make sure the male and female connectors have the correct polarity (+/-) before connecting. The servo lead and receiver case are molded so that the lead can only be inserted correctly. Be sure to orient the servo plug correctly for proper insertion.

You may use a separate battery to power the receiver (such as for some electric boats or in gas-powered vehicles). A NiCad pack plugged into the BATT socket on your receiver will operate your receiver. You may also use alkaline batteries with an optional battery holder (part no. *JRPA020*).

If you use a mechanical speed controller, please ensure that it has the correct connector for a B.E.C. system (red connector). See FIGURE A for a typical setup.

Most electronic speed controllers are set up for B.E.C. operation and plug directly into your receiver (Function 2). See FIGURE B for a typical setup and check your speed controller's manual for correct installation.

You should use the black rubber servo cushions whenever possible to decrease your servo's sensitivity to vibration.

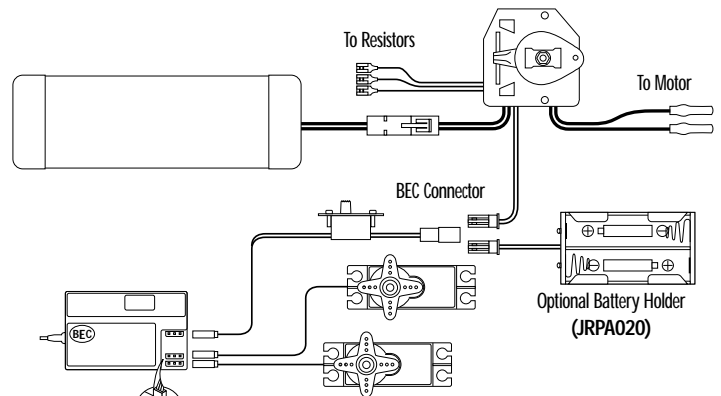

FIGURE A – Connections to B.E.C. receiver with mechanical speed controller. NiCad battery, speed controller and battery holder are not included in the radio set.

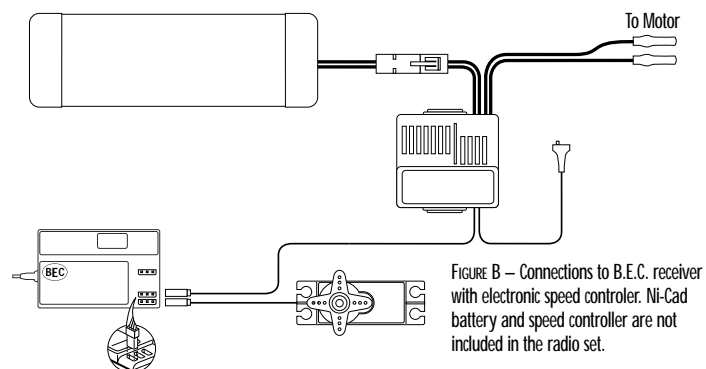
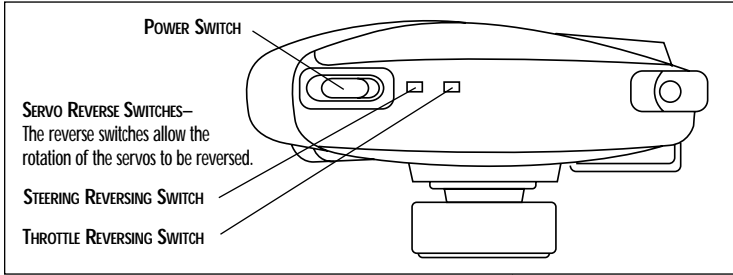
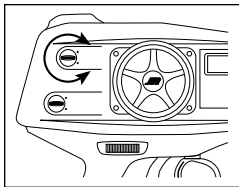
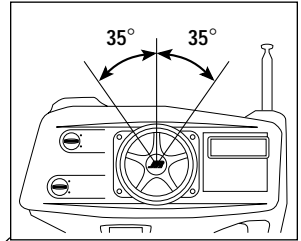

FIGURE B – Connections to B.E.C. receiver with electronic speed controller. NiCad battery and speed controller are not included in the radio set.

## VI. IDENTIFICATION OF TRANSMITTER PARTS



**STEERING WHEEL** —  
The steering wheel rotates 35° to the left and to the right.



**STEERING TRIM** — Rotate the top trim tab to adjust and obtain the neutral position of the steering servo.

**HINT:** Setting your steering linkage:

1. Make sure your steering rate adjuster (see call-out at right) is set to the maximum position and your steering trim is centered.
2. Turn on the power to your receiver to center the steering servo and set the linkage for maximum travel. Then use the rate adjuster to adjust the amount of travel you need.

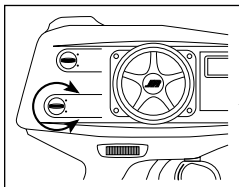

**THROTTLE TRIM** — Rotate the bottom trim knob to adjust and obtain the neutral position of the throttle servo.

**LED VOLTAGE METER** — If the meter indicates green, your batteries are approximately full strength. If the meter indicates orange or red, the batteries are weak and need to be replaced with new cells or charged if you are using rechargeable "AA" NiCads.

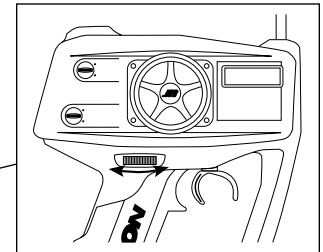

**STEERING RATE ADJUSTER** — The steering rate adjuster affects the throw of the steering servo. The output can be adjusted from approximately 10% to 100%. The throw of the servo decreases as you move the dial to the left.

**HINT:** Use this to decrease the sensitivity of your steering on loose courses and on courses without tight curves.

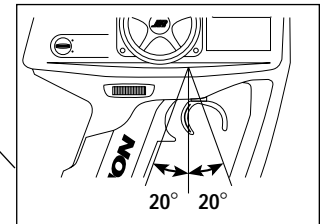

**THROTTLE TRIGGER** — The throttle trigger moves 20° in the forward and reverse direction.

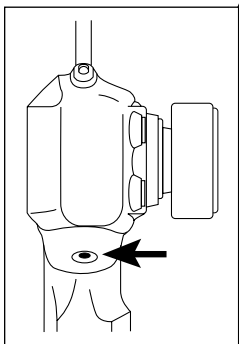

**CHARGING JACK** — Your Python transmitter can be upgraded to NiCad batteries using the optional Dynamite DYN1900 NiCad Conversion Kit.

**JR POLARITY:**  (Center pin negative)

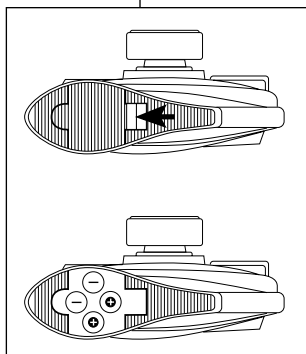

**BATTERY CASE** — To remove the battery cover, slide the tab in the direction of the arrow while pushing the rounded tab.

Install the 8 "AA" batteries according to the diagram.

If the transmitter voltage fails to register, check for the correct installation of the batteries and make sure the batteries still have a charge.

### BACK OF TRANSMITTER

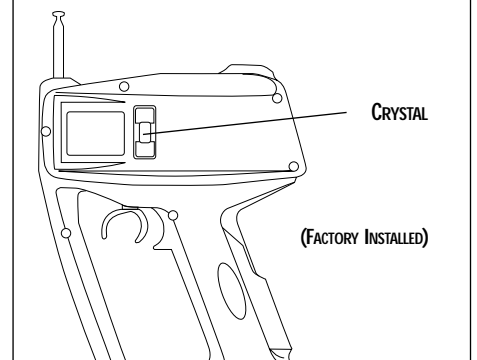

## VII. PARTS LISTING

JRPA159	TX Antenna
JRPA225	Servo Grommets (20)
JRPA233	Servo Eyelets (20)
JRPA226	Servo Mounting Screws (20)
JRPA210	Offset Horn w/Screw (2)
JRPA212	Large Arm w/Screw (2)
JRPSCZ250	Servo Case
JRPSGZ250	Servo Gear Set
JRPXAG**	AM Crystal Set

### OPTIONAL PARTS

JRPA011	Switch Harness for BEC
JRPA020	4-Cell RX Battery Case
JRPC221	TX/RX Charger
DYN1900	NiCad Conversion Kit

## VIII. FREQUENCY CHART

FREQUENCY (MHz)	CHANNEL	FREQUENCY (MHz)	CHANNEL	FREQUENCY (MHz)	CHANNEL
26.995.....	1	75.530.....	67	75.770.....	79
27.045.....	2	.550.....	68	.790.....	80
.095.....	3	.570.....	69	.810.....	81
.145.....	4	.590.....	70	.830.....	82
.195.....	5	.610.....	71	.850.....	83
.255.....	6	.630.....	72	.870.....	84
75.410.....	61	.650.....	73	.890.....	85
.430.....	62	.670.....	74	.910.....	86
.450.....	63	.690.....	75	.930.....	87
.470.....	64	.710.....	76	.950.....	88
.490.....	65	.730.....	77	.970.....	89
.510.....	66	.750.....	78	.990.....	90

## IX. PYTHON RECEIVER CRYSTAL COMPATIBILITY

### NER-102 STANDARD RECEIVER

Your Python's NER-102 receiver has been designed to use **only** a JR "green" receiver crystal (JRPXAG\*\* TX/RX crystal set). JR "grey" receiver crystals (JRPXAR\*\*) are not designed to be used with the NER-102 receiver, and will reduce the usable range of the receiver.

### R122 OPTIONAL RECEIVER

JR's optional R122 receiver is designed for use with JR "grey" receiver crystals **only** (JRPXAR\*\*). The JR "green" receiver crystals (JRPXAG\*\* Tx/Rx crystal set) included with your Python system are not compatible with the R122 receiver and should not be used.

\*\* Replace with channel number when ordering.

## X. WARRANTY AND SERVICE INFORMATION

### IMPORTANT NOTE

Be sure to keep your original dated sales receipt in a safe place as you will be required to provide proof of purchase date for the equipment to be serviced under warranty.

### WARRANTY COVERAGE

Your new JR Remote Control Radio System is warranted to the original purchaser against manufacturer defects in material and workmanship for 365 days from the date of purchase. During this period, Horizon Service Center will repair or replace, at our discretion, any component that is found to be factory defective at no cost to the purchaser. This warranty is limited to the original purchaser of the unit and is not transferable.

This warranty does not apply to any unit which has been improperly installed, mishandled, abused or damaged in a crash, or to any unit which has been repaired or altered by any unauthorized agencies. Under no circumstances will the buyer be entitled to consequential or incidental damages. This limited warranty gives you specific legal rights; you also have other rights which may vary from state to state. As with all fine electronic equipment, do not subject your radio system to extreme temperatures, humidity or moisture. Do not leave it in direct sunlight for long periods of time.

### REPAIR SERVICE DIRECTIONS

In the event that your JR radio needs service, please follow the instructions listed below.

1. Check all ON/OFF switches to be sure they are off. This will speed the repair process of checking battery condition.
2. Return your system components only (transmitter, receiver, servos, etc.) Do not return your system installed in a model car, boat, etc.

3. Preferably, use the original carton/packaging (molded foam container) or equivalent to ship your system. Do not use the system carton itself as a shipping carton. You should package the system carton within a sturdy shipping container using additional packing material to safeguard against damage during transit. Include complete name and address information inside the carton, as well as clearly writing it on the outer label/return address area.
4. Include detailed information explaining your operation of the system and problem(s) encountered. Provide an itemized list of equipment enclosed and identify any particular area/function which may better assist our technicians in addressing your concerns. Date your correspondence, and be sure your complete name and address appear on this enclosure.
5. Include you name, mailing address, and a phone number where you can be reached during the business day.
6. **WARRANTY REPAIRS.** To receive warranty service you must include your original dated sales receipt to verify your proof-of-purchase date. Providing that warranty conditions have been met, your radio will be repaired without charge.
7. **NORMAL NON-WARRANTY REPAIRS.** Should your repair cost exceed 50% of the retail purchase cost, you will be provided with an estimate advising you of your options.

Within your letter, advise us of the payment method you prefer to use VISA or MasterCard. Please include your card number and expiration date.

Mail your system to: Horizon Service Center  
4105 Fieldstone Road  
Champaign, IL 61822  
Phone: (217) 355-9511  
www.horizonhobby.com