



INSTRUCTION MANUAL
FOR AIRPLANE,
HELICOPTER,
AND
SAILPLANE



X-378

7-CHANNEL COMPUTER
RADIO SYSTEM

TABLE OF CONTENTS

I. INTRODUCTION

Table of Contents	2
1. Using The Manual	4
2. Features	4
2.1 Transmitter	4
2.2 Receiver	4
2.3 Servo Features	5
3. Component Specifications	
3.1 System Specifications	5
3.2 Transmitter Specifications	5
3.3 Servo Specifications	6
3.4 Receiver Specifications	6
3.5 Charger Specifications	6
3.6 Airborne Battery Pack	6
4. Battery Charging	7
4.1 Transmitter/Receiver	7
4.2 Charger	7
4.3 Advanced Digital Trims	8

II. AIRPLANE SECTION

1. Software Functions	
1.1 Control Identification and Location	9
1.2 Channel Assignment/Throttle ALT	9
A. Airplane Version Transmitter	9
B. Sailplane Mode	10
C. Heli Mode	10
1.3 Transmitter Rear	11
1.4 Control Stick Length Adjustment	12
1.5 Control Stick Tension Adjustment	12
1.6 Direct Servo Control	12
1.7 Neck Strap Attachment	13
1.8 Base Loaded Antenna	13
1.9 Frequency Notes/Aircraft Only Frequencies	13
2. Connections	
2.1 Installation Requirements	14
2.2 Connections	14
3. Mode Input an Function	15
4. Alarm and Error Display	15
4.1 Battery Alarm and Display	15
4.2 Backup Error Display	15
5. System Mode Function	16
5.1 Normal Display	16
5.2 Direct Access Digital Trims	16
5.3 System Mode	17
5.4 Model Selection/Copy Select	18
5.5 Model Name Entry	20
5.6 Model Type Selection	21
5.7 Data Reset	22
5.8 Modulation Select	23
5.9 Data Transfer	24
5.10 Trim Step	25
5.11 Throttle Cut Switch	26
5.12 Wing Type Selection	27
5.13 Aux 2/Spoiler Channel Input Select	30
6. Function Mode	
6.2 Servo Reversing	31
6.3 Dual-Rates	33
6.4 Exponential	35
6.5 Sub Trim	38

6.6 Travel Adjust	39
6.7 Elevator-to-Flap Mixing	40
6.8 Aileron-to-Rudder Mixing	42
6.9 Mode Function	44
6.10 Snap Roll Function	46
6.11 Differential Aileron Mixing	48
6.12 Landing Attitude	50
6.13 Programmable Mixing	51
6.14 Fail Safe/Hold	55
6.15 Trainer System	59
6.16 Timer Function	62
7. Practical Applications	64
7.1 Programmable Mixing Options	64
8. Data Sheet	65

III. HELICOPTER

1. Transmitter Controls	66
1.1 Control Identification and Location	66
A. Helicopter Version Transmitter	66
1.2 Channel Assignment/Receiver	66
1.3 Transmitter Rear	68
1.4 Control Stick Length Adjustment	69
1.5 Control Stick Tension Adjustment	69
1.6 DSC Cord	69
1.7 Neck Strap Attachment	70
1.8 Base Loaded Antenna	70
1.9 Frequency Notes/Aircraft Only Frequencies	70
2. Connections	71
2.1 Installation Requirements	71
2.2 Connections	71
3. Key Input and Display	72
4. Alarm and Error Display	72
4.1 Battery Alarm and Display	72
4.2 Backup Error Display	72
5. System Mode	73
5.1 Normal Display	73
5.2 System Mode	73
5.3 Function Mode	74
5.4 Model Selection/Model Copy Select	75
5.5 Model Name Entry	77
5.6 Model Type Selection	78
5.7 Data Rest	79
5.8 Modulation Select	80
5.9 Data Transfer	81
5.10 Trim Step	84
5.11 Throttle Cut Switch Activation	85
5.12 Aux/Gear Function Select	86
5.13 Swashplate Type	87
6. Function Mode	88
6.1 Function Mode	88
6.2 Servo Reversing	89
6.3 Dual-Rates	90
6.4 Exponential	92
6.5 Sub Trim	93
6.6 Travel Adjust	94
6.7 CCPM Swashplate Mixing	95
6.8 Throttle Hold	97
6.9 Throttle Curve	98
6.10 Pitch Curves	101
6.11 Inverted Switch	103

TABLE OF CONTENTS

6.12	Revolution Mixing	104	6.18	Timer Function	177
6.13	Gyro Gain Function	106	7. Practical Applications		179
6.14	Programmable Mixing	110	7.1	X-378 Program	179
6.15	PCM Fail-Safe/Hold Function	114	8. Data Sheets		184
6.16	Trainer System	117			
6.17	Timer Function	119	V. IMPORTANT INFORMATION		
7. Data Sheet		121	1. Servo Precautions		185
IV. SAILPLANE			2. General Notes		185
1. Transmitter Controls			3. Federal Aviation Administration		186
1.1 Control Identification and Location	122		4. Daily Flight Checks		186
A. Glider Version Tx	122		5. Frequency Chart		187
B. Airplane Mode	123		6. Warranty Information		188
C. Heli Mode	123				
1.2 Channel Assignment/Throttle ALT	123				
1.3 Transmitter Rear	124				
1.4 Control Stick Length Adjustment	125				
1.5 Control Stick Tension Adjustment	125				
1.6 DSC Cord	125				
1.7 Neck Strap Adjustment	126				
1.8 Base Loaded Antenna	126				
1.9 Frequency Notes/Aircraft Only Frequencies	126				
2. Connections					
2.1 Installation Requirements	127				
2.2 Connections	127				
3. Key Input and Display	128				
4. Alarm and Error Display	128				
4.1 Battery Alarm and Display	128				
4.2 Back-Up Error Display	128				
5. System Mode	128				
5.1 Normal Display	128				
5.2 Model Setup Mode	129				
5.3 Function Mode	130				
5.4 Model Selection/Model Copy Select	131				
5.5 Model Name Entry	133				
5.6 Model Type Selection	134				
5.7 Data Rest	135				
5.8 Modulation Select	136				
5.9 Data Transfer Function	137				
5.10 Trim Step	140				
5.11 V-Tail/Dual Flap Wing Mixing	141				
5.12 Flap Switch Select Function	143				
6. Function Mode					
6.1 Function Mode	144				
6.2 Servo Reversing	145				
6.3 Dual Rates	146				
6.4 Exponential	148				
6.5 Sub Trim	149				
6.6 Travel Adjust	150				
6.7 Elevator-to-Flap Mixing	151				
6.8 Aileron-to-Flap Mixing	153				
6.9 Differential Aileron Mixing	155				
6.10 Flap to Elevator Mixing	156				
6.11 Flap-to-Aileron Mixing	159				
6.12 Aileron-to-Rudder Mixing	162				
6.13 Crow/Camber Mixing	164				
6.14 Dual-Flap Trim	166				
6.15 Programmable Mixing 1-6	167				
6.16 Fail-Safe/Hold Function (PCM Only)	171				
6.17 Trainer System	175				

CHAPTER 1: USING THIS MANUAL • Introduction

1

USING THIS MANUAL

In the beginning of this manual you will find the specifications for the radio and its various accessories. In addition, guidelines for the initial installation of the accessories have been included, as well as instructions for setting all the functions and programs of the X-378 to suit your personal preferences. These features are discussed in the same order that they will appear on your radio, as you will see on the accompanying charts. An explanation of the use and purpose of each feature is provided, followed by a labeled illustration of its respective LCD display.

In addition, a step-by-step example clarify the setup procedure of the feature. Practical applications for many of the radio's features enable you to see their true purpose and additional possibilities. A blank data sheet has been included at the end of each

section. Once all data has been input for a particular model, it is highly recommended that you record it on a copy of the sheet provided. If you should experience memory loss or battery failure or want to make changes to the current settings, this step will save you a great deal of time. Following the data sheet, you will find information on precautionary measures and general guidelines for safe use of your new equipment.

Use of the Instructions with the Radio

While the X-378 has a dedicated or single-use switch layout, it may be used for multiple model types. Templates have been provided in this manual that explain the different switch assignments when using the transmitter with the various air, heli and sailplane software.

CHAPTER 2: FEATURES

2.1

X-378 TRANSMITTER

The computer designed, ergonomically styled transmitter case ensures a good, comfortable fit in your hands. The ultra-precision control sticks offer adjustable spring tensions and length. The throttle stick offers a ratchet in Airplane configuration for smooth travel. 8-model memory storage allows programming of all characteristics of eight separate helicopters, airplane or gliders; you can program more than one setup for a single aircraft, allowing you to instantly change the flight characteristics.

A five-year lithium backup battery prevents loss of memory in the event that the battery discharges completely or is removed.

Features include automatic fail-safe "set" and information update in PCM mode when fail-safe is used. A programmable trainer function allows the student to practice individual channels separately. Direct Servo Control (DSC) permits operation of all the controls and servos without generating a radio signal.

2.2

R700 RECIEVER

NER-700 (FM Systems)

The R700's is a high-performance FM or single-conversion receiver with 10KHz super narrow band ABC&W circuitry.

A narrow band ceramic filter for high-signal selectivity assists in rejecting cross modulations

from other common radio frequencies-e.g., R/C transmitters, local paging systems. This receiver features Direct Servo Control (DSC) for control of surfaces without radio frequency output.

The receiver has low current consumption.

The R700's Slimline design allows it to fit into most model applications.

2.3

S537 BALL BEARING SERVOS**537 Servo**

- Wide spaced ball bearing for precise movement of your aircraft control outputs
- A zero deadband amplifier insures accurate neutral centering
- Low current drain
- Indirect drive feedback potentiometer gives additional protection from vibration
- 3-pole ferrite cored motor

CHAPTER 3: COMPONENT SPECIFICATIONS

3.1

SYSTEM SPECIFICATIONS

TYPE	AIRPLANE	HELICOPTER
SYSTEM NAME	X-378A	X-378H
TRANSMITTER BODY	NET-K227FS	Net-K227HS
TRANSMITTER RF MODULE	NET-J72P	NET-J72P
RECEIVER	R700 (FM)	R700 (FM)
CHARGER	NEC-221	NEC-222
AIRBORNE BATTERY	600mah	1100mah
SERVOS	NES-537X4	NES-537X5
ACCESSORIES	Standard Switch 12" Aileron Extension Charge Jack Servo Accys Hex Wrench Instruction Manual	Standard Switch 12" Aileron Extension Charge Jack Servo Accys Hex Wrench Instruction Manual

3.2

TRANSMITTER SPECIFICATIONS

TYPE	AIRPLANE	HELICOPTER
MODEL NUMBER	NET-K227FS	Net-K227HS
ENCODER	7-channel computer system	7-channel computer system
RF MODULE	72MHz	72MHz
MODULATION	PCM (z or s) or PPM	PCM (z or s) or PPM
OUTPUT POWER	Approximately 750mw	Approximately 750mw
CURRENT DRAIN	200mA (70mA with DSC)	200mA (70mA with DSC)
POWER SOURCE	1.2Vx Ni-Cd (9.6V) 600mAh	1.2Vx Ni-Cd (9.6V) 600mAh
OUTPUT PULSE	1000-2000 (1500 Neutral)	1000-2000 (1500 Neutral)

3.3

SERVO SPECIFICATIONS

TYPE	537
TORQUE (ounce inch)	43 oz/in
SPEED (sec/60°)	.25 60°
WEIGHT	1.58
SIZE (in) (W x L x H)	1.52 x 0.73 x 1.32
BB	Single
MOTOR	3-Pole Ferrite

3.4

RECEIVER SPECIFICATIONS

TYPE	FM
MODEL NUMBER	R700
TYPE	7 Channel / FM-ABC&W / Micro
FREQUENCY	72MHz
SENSITIVITY (Microseconds)	5 uS minimum
SELECTIVELY	8KHz / 5 dB
WEIGHT (oz)	1.5
RECEIVER ANTENNA	39" for all aircraft frequencies

3.5

CHARGER SPECIFICATIONS

TYPE	AIRCRAFT	HELICOPTER
MODEL NUMBER	NEC-221	NEC-222
INPUT VOLTAGE	AC 100-120V	AC 100-120V
OUTPUT CURRENT	50mAh TX/50mAh RX	50mAh TX/120mAh RX
CHARGING TIME	15 Hours	15 Hours

3.6

AIRBORNE BATTERY PACK

TYPE	AIRCRAFT	HELICOPTER
MODEL NUMBER	B600	B1000
VOLTAGE	4.8V	4.8V
SIZE (in) (W x L x H)	2.24 x 0.59 x 2.05	2.24 x 0.63 x 1.70
WEIGHT (oz)	3.3	4.9

CHAPTER 4: BATTERY CHARGING

4.1

TRANSMITTER/RECEIVER

Note: It is imperative that you fully charge both the transmitter and the receiver battery packs prior to each flight. To do so, leave the charger and batteries hooked up overnight (16 hours). The first charge should be approximately 20–24 hours in order to fully charge both battery packs to peak capacity.

The charger supplied with this system is designed to recharge your batteries at a rate of 5mAh for the transmitter and 50mAh for the receiver battery pack.

Transmitter Only

The center pin on all JR Remote Control Systems is negative. Therefore, the center pin on all JR chargers is negative, not positive. This is different from many other manufacturers' chargers and radio systems. Beware of improper connections based on "color-coded" wire leads, as they do not apply in this instance. You must make sure that the center pin of your JR transmitter is always connected to the negative voltage for correct polarity hookup.

Important: Please note that the charging polarity of the transmitter and receiver are different.

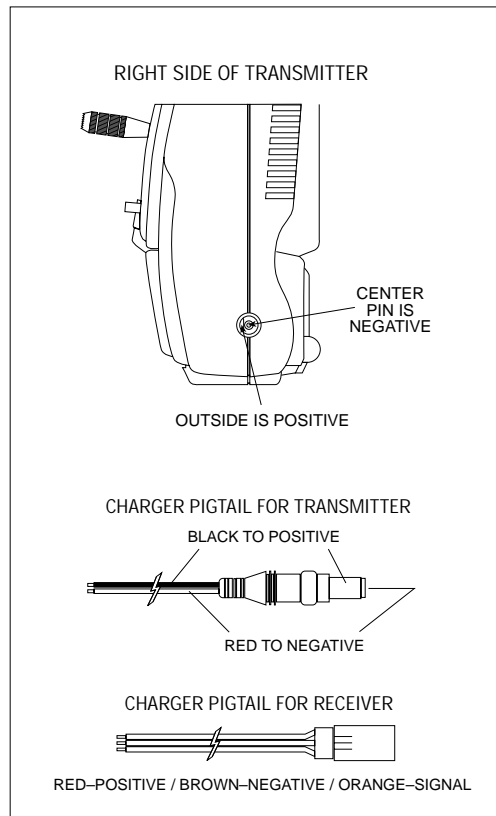

4.2

CHARGER

The pilot lamps should always be on during the charging operation. If not, check to make sure that both the transmitter and receiver are switched off. Do not use the charger for equipment other than JR. The charging plug polarity may not be the same. Equipment damage can result.

Do not use other manufacturers' after-market accessories that plug into the transmitter's charging jack. If you do, any damage that results will not be covered by warranty. If you are unsure of compatibility issues with your radio, seek expert advice before

doing anything to avoid possible damage.

During the charging operation, the charger's temperature is slightly elevated. This is normal. Also, note that the voltage shown on the charger is higher than the battery in use. This voltage cannot be measured with a voltmeter. Only current can be measured with any accuracy using this type of charger.

Be sure to use the proper charger (120mAh) when using battery packs of 1000mAh or larger for your receivers.

4.3

ADVANCED DIGITAL TRIMS

Your new X-378 system employs four digital trim levers for unmatched precision and adjustability. By using the Trim Step function located in the System mode, the movement of the ADT trims can be fine tuned as needed to match your specific application.

The ADT feature is also designed to automatically save the determined trim values for each model. When the X-378 is changed between models in the Model Select function, the digital trim values will automatically stay with each model, eliminating the need for a separate trim memory function.

The X-378's digital trims also feature the Direct Access display function. While at the Normal display screen, if a trim lever is moved, the screen

will automatically change to display the numeric value, as well as the graphic position for the trim being adjusted.

The X-378's digital trims also feature 2-speed scrolling. When a substantial amount of trim is required, holding the trim in the desired position will activate the dual speed scrolling function. The X-378's Aileron, Elevator, and Rudder trim levers (also throttle in sailplane mode) feature an audible center trim beep. This is helpful in determining the trim levers center position during flight.

Please also note that unlike conventional mechanical trim levers, when the X-378 transmitter is in the off position, no changes can be made to the trim values during transportation.

One Touch Digital Throttle Trim Lever (Air and Heli Modes only)

The X-378 also features a revolutionary One-Touch Digital Throttle Trim lever. While in Air or Heli modes, the X-378 will remember the maximum high Throttle Trim position (usually idle) set from the previous flight. At the end of the flight, move the Throttle Trim to the full low (engine off) position. For the next flight, by simply pressing the Digital Throttle Trim up once, the throttle trim value will automatically move to the position from the previous flight. Trim value changes can then be made by moving the throttle trim lever as needed.

The Direct Access Digital Trim function will display the throttle trim value numerically and also

graphically on the screen automatically each time the Throttle Trim is moved

This feature is very helpful as once you have set the correct throttle trim value for a proper idle, the X-378 will allow the Trim lever to be set back to this position for each flight, eliminating the need to set the exact throttle trim value for each flight.

Note: When the X-378 is in the glider (sailplane) model type, the Digital Throttle Trim works as a conventional trim lever, which is the most desirable method in this mode.

SECTION II • CHAPTER 1: SOFTWARE FUNCTIONS Airplane

1.1 CONTROL IDENTIFICATION AND LOCATION

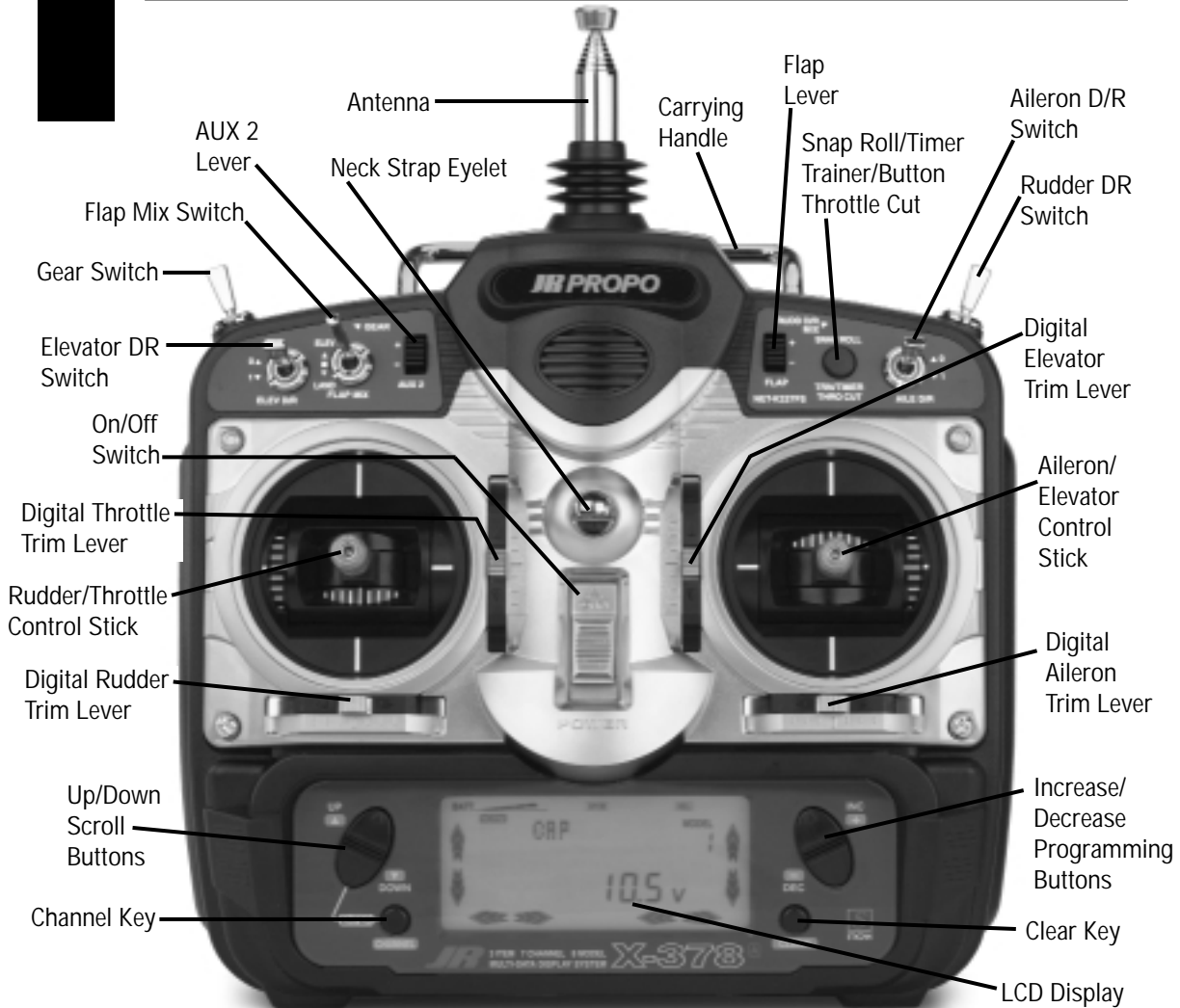

1.2 CHANNEL ASSIGNMENT/THROTTLE ALT

CHANNEL ASSIGNMENT

Channel	TX Function	Airplane Function
1	THRO	Throttle Channel
2	AILE	Aileron Channel
3	ELEV	Elevator Channel
4	RUDD	Rudder Channel
5	GEAR	Gear Channel
6	AUX 1	Auxiliary 1 Channel (Flap)
7	AUX 2	Auxiliary 2 Channel (Spoiler)

Throttle ALT

The Throttle ALT function makes the throttle stick trim active only when the throttle stick is at less than half throttle. This gives easy, accurate idle adjustments without affecting the high throttle position.

CHAPTER 1: SOFTWARE FUNCTIONS Airplane

Airplane Version Transmitter—Sailplane Mode

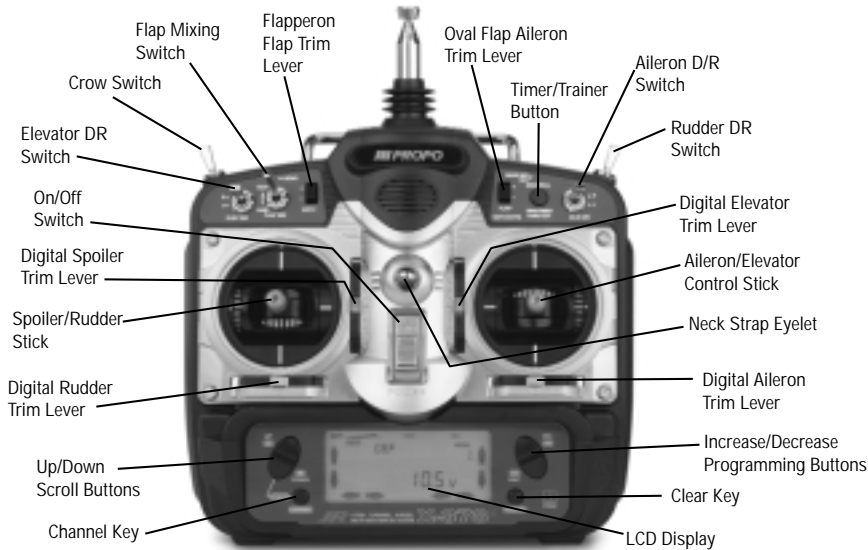

CHANNEL ASSIGNMENT

1. THRO	Throttle Channel	5. GEAR	Gear Channel
2. AILE	Left Aileron Channel	6. AUX 1	Auxiliary 1 Channel
3. ELEV	Elevator Channel	7. AUX 2	Auxiliary 2 Channel
4. RUDD	Rudder Channel		(Right Flap Channel for Dual Flaps)
			(Left Flap Channel for Dual Flaps)

Airplane Version Transmitter-Heli Mode

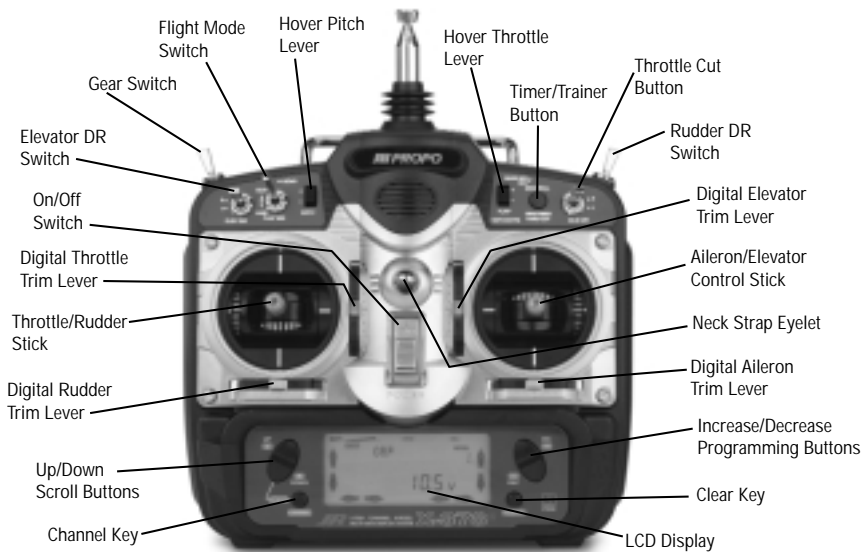

CHANNEL ASSIGNMENT

1. THRO	Throttle Channel	5. GEAR	Gear Channel
2. AILE	Aileron Channel	6. AUX 1	Auxiliary 1 Channel (Pitch)
3. ELEV	Elevator Channel	7. AUX 2	Auxiliary 2 Channel
4. RUDD	Rudder Channel		(Gyro Sensitivity)

CHAPTER 1: SOFTWARE FUNCTIONS Airplane

1.3

TRANSMITTER REAR

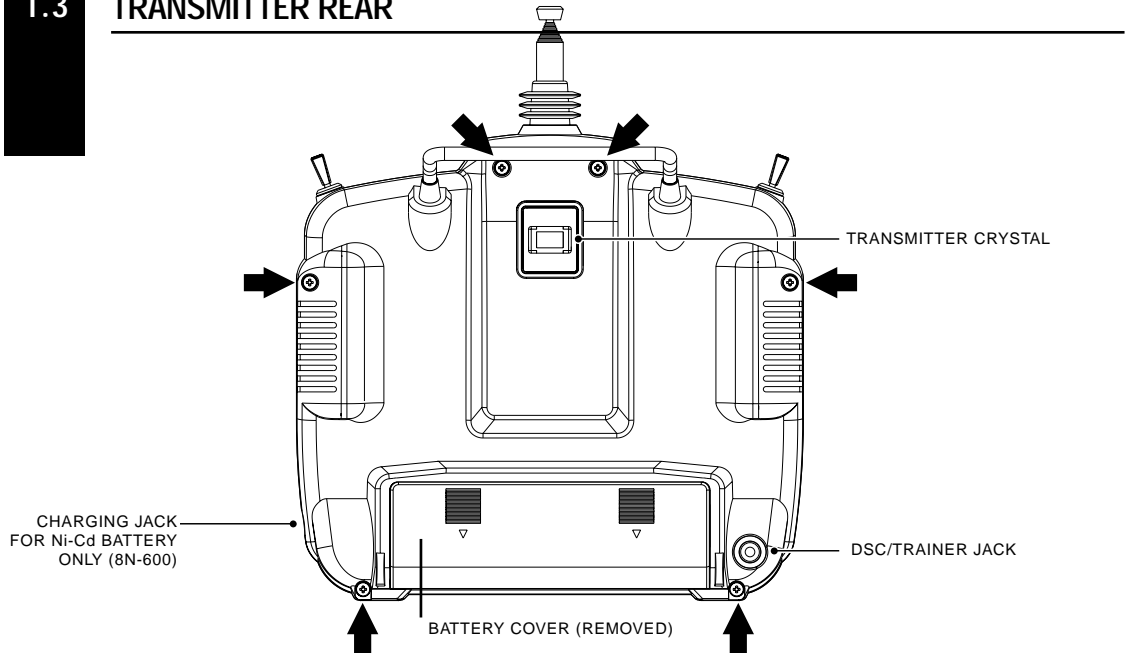

CAUTION: THE BATTERY CONNECTOR IS KEYSO THAT IT CAN ONLY BE PLUGGED IN ONE DIRECTION. **DO NOT FORCE.**

Transmitter Crystal Replacement Notice
 The Federal Communications Commission (FCC) requires that changes in transmitter frequency must be performed only by an authorized service technician (Horizon Service Center). Any transmitter frequency change made by non-certified technician may result in a violation of the FCC rules.

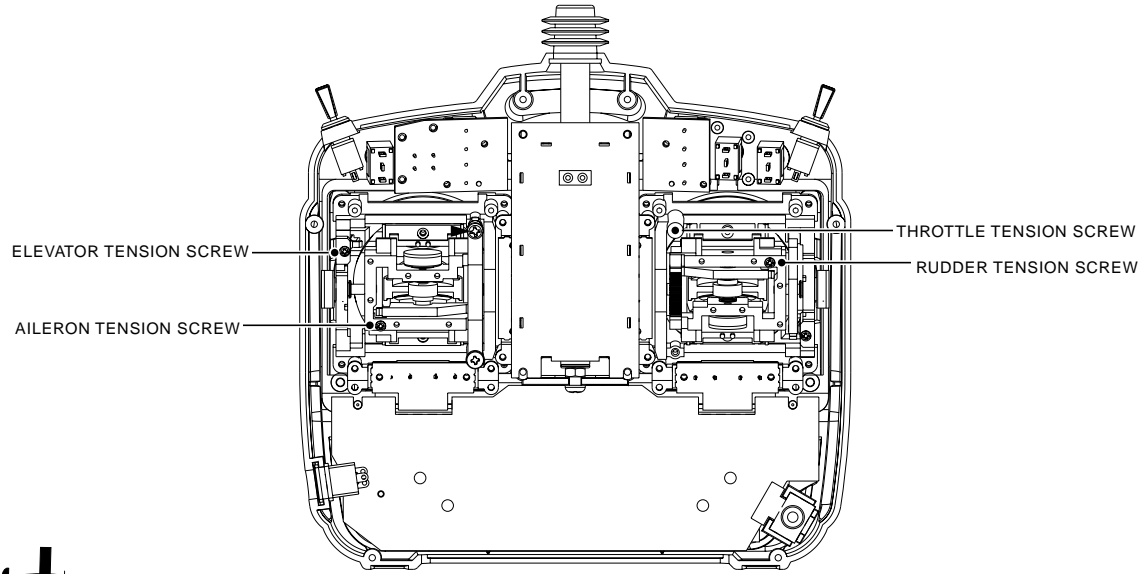

CHAPTER 1: SOFTWARE FUNCTIONS • Airplane

1.4 CONTROL STICK LENGTH ADJUSTMENT

To adjust the stick length, use the 2mm Allen wrench (supplied with your X-378 transmitter) to unlock the set screw. Turn the wrench counterclockwise to loosen the screw. Then, turn the stick clockwise to shorten or counterclockwise to lengthen. After the control stick length has been adjusted to suit your flying style, tighten the 2mm set screw. If you desire longer sticks, JR offers a thicker stick (JRPA047) that is approximately one inch longer than the standard stick. This stick, crafted from bar stock aluminum, is available at your local JR dealer.

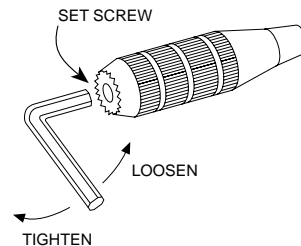

1.5 CONTROL STICK TENSION ADJUSTMENT

Remove the Ni-Cd battery and six transmitter back screws as shown on the previous page. Remove the transmitter back, being careful not to cause damage to any components.

Adjust each screw for desired tension (counterclockwise to loosen stick feel; clockwise to tighten stick feel). When adjusting the throttle ratchet tension, make sure that the adjusting screw does not touch the PC board after adjustment is complete.

1.6 DIRECT SERVO CONTROL (DSC)

For proper DSC hook-up and operation:

1. Leave the transmitter power switch in the Off position. The transmitter will not transmit any radio frequency (RF) in this position.
2. Plug the (supplied) DSC cord into the DSC port in the rear of the transmitter.
3. The encoder section of the transmitter will now be operational and the LCD display will be lit.
4. Plug the other end of the DSC Cord into the receiver charge receptacle. Turn the switch harness to the On position.

Note: When you install the charging jack, be sure to hook the charging jack receptacle securely into the switch harness charge cord.

Why you should use the DSC function:

1. The DSC enables you to check the control surfaces of your aircraft without drawing the fully operational 200mAh from your transmitter battery pack. Instead, you will only draw 70mAh when using the DSC function.

2. The DSC function allows you to make final adjustments to your airplane without transmitting any radio signals. Therefore, if another pilot is flying on your frequency, you can still adjust your aircraft and not interfere with the other pilot's aircraft.

Note: Under no circumstances should you attempt to fly your aircraft with the DSC cord plugged in! This function is for bench-checking your airplane only.

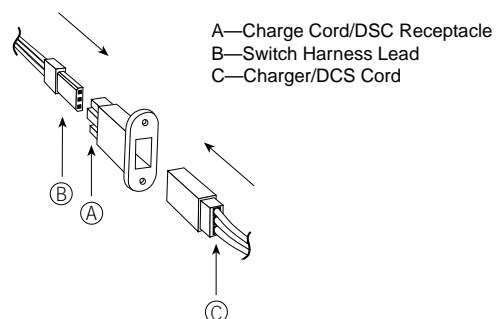

CHAPTER 1: SOFTWARE FUNCTIONS • Airplane

1.7 NECK STRAP ATTACHMENT

An eyelet is provided on the face of the X-378 transmitter that allows you to connect a Neck Strap (JRPA023). This hook has been positioned so that your transmitter has the best possible balance when you use the neck strap.

Note: Double-check to ensure that the neck strap is securely fastened to the transmitter.

1.8 BASE LOADED ANTENNA

An optional base-loaded antenna is available for use with the X-378 transmitter. It is considerably shorter than the standard antenna. However, the base loaded antenna cannot be collapsed for storage in the side of the transmitter. You must also use an

adaptor (JRPA156) to attach the antenna to your X-378. The Base Loaded Antenna (JRPA155) is made of a flexible coil and is covered with a soft plastic material. Your range will not be affected when using the base loaded antenna.

1.9 FREQUENCY NOTES/AIRCRAFT ONLY FREQUENCIES

The X-378 transmitter employs a plug-in crystal for transmitter that is glued in place at the time of shipment. Per FCC regulation, the transmitter crystal should only be changed by a certified technician. Changing of the transmitter crystal by a non-authorized technician could result in a violation of FCC rules.

The X-378 can transmit in either Pulse Code Modulation (PCM) or Pulse Position Modulation (PPM, commonly referred to as FM).

Be certain to observe the following guidelines:

1. Do not operate your transmitter when another transmitter is using the same frequency, regardless of whether the second transmitter is PCM, PPM (FM) or AM. You can never operate two transmitters on the same frequency simultaneously without causing interference to both receivers and crashing both aircraft.

2. For operation of your X-378 with additional receivers, you should refer to the receiver compatibility chart. The chart is located in the Modulation Selection Section of this manual.

Aircraft-Only Frequencies

JR Transmitters and receivers are available in 72MHz frequencies in the United States for use with model aircraft. Employing 72MHz frequencies does not require a special operator's license from the Federal Communications Commission (FCC).

* A chart for all available frequencies is located on page 185 of this manual.

CHAPTER 2: CONNECTIONS • Airplane

2.1 INSTALLATION REQUIREMENTS

It is extremely important that your radio system be correctly installed in your model. Here are a few suggestions on the installation of your JR equipment:

1. Wrap the receiver in protective foam rubber that is no less than 3/8 inch thick. Secure the foam to the receiver with #64 rubber bands. This protects the receiver in the event of a crash or a very hard landing.
2. The servos should be mounted using rubber grommets and brass bushings to isolate them from vibration. Do not over-tighten the mounting screws; this will negate the vibration absorption effect of the rubber grommets. The following diagram will assist you properly mounting your servo.



3. The servos must be able to move freely over their entire range of travel. Make sure that the control linkages do not bind or impede the movement of any of the servos.
4. Mount all switches away from the engine exhaust and away from any high vibration areas. Make sure the switch operates freely and is able to operate over its full travel.
5. Mount the receiver antenna firmly to the airplane to ensure that it will not become entangled in the propeller or control surfaces.

2.2 CONNECTIONS

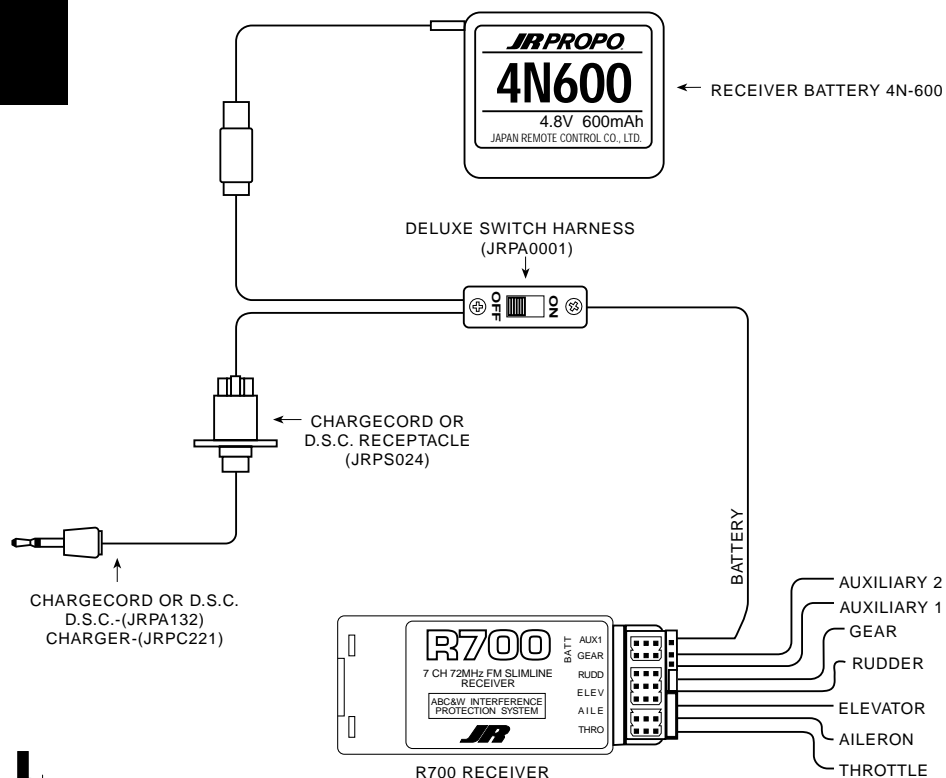

CHAPTER 3: INPUT MODE AND FUNCTION • Airplane

3 KEY INPUT AND DISPLAY

The *Function Selection* keys are used to move up and down through the functions. The *Channel* key is used to advance the channel or function selected. The

Increase and *Decrease* keys are used to make changes in the selected functions.

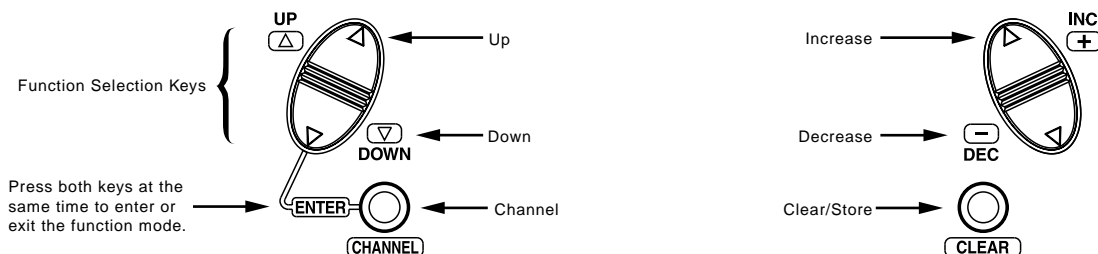

CHAPTER 4: ALARM AND ERROR DISPLAY • Airplane

4.1 BATTERY ALARM AND DISPLAY

When the transmitter voltage drops below 9.0 volts DC, the display flashes "BATT" and an alarm sounds

seven times. If you are flying when this occurs, land immediately.

4.2 BACKUP ERROR DISPLAY

All preprogrammed data is protected by a five-year lithium battery that guards against main transmitter battery failure. Should the lithium battery fail, the display will indicate ERR1 regardless of the position of the On/Off switch. If this occurs, it will be necessary to replace the battery and reprogram all data. All transmitter programs will return to the factory default settings, and the data you have input will be lost. When it becomes necessary to replace the lithium back-up battery, contact JR Horizon

Service Center. Due to the possibility of extensive damage caused by improper removal or replacement, only JR Horizon Service Center is authorized to make this change.

ERR1



CHAPTER 5: SYSTEM MODE • Airplane

5.1 NORMAL DISPLAY

When the power switch is in the On position, the display will read as follows:

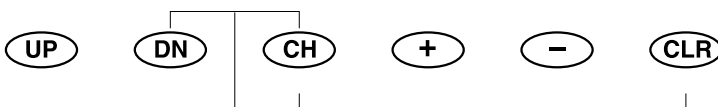
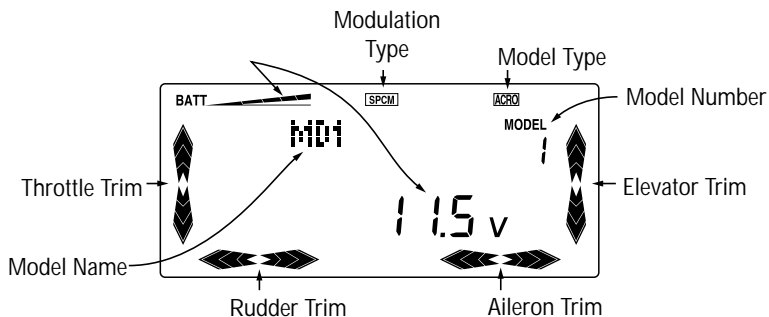

To enter the System mode, press simultaneously then turn on the power switch. To enter the Function model, turn on the power switch, then press simultaneously.

In the Timer mode, press the *Channel* key to start/stop the timer, and press the *Clear* key to reset the timer.

5.2 DIRECT ACCESS DIGITAL TRIMS

The X-378 is equipped with a Direct Access Digital Trim Value function. When at the normal display, if a digital trim lever is moved, the screen will automatically change to show the current trim value for the channel being adjusted. When the trim is returned to center, the screen will change back to the normal display screen after a few seconds.



Current trim value for the channel being adjusted



CHAPTER 5: SYSTEM MODE • Airplane

5.3 SYSTEM MODE

To enter the System mode, press the *Down* and *Channel* keys simultaneously, then turn the power switch to the on position. The display will show the last active program. Pressing either the *Up* or *Down* key then scrolls through the functions one by one, according to the system mode flowchart shown to the right. Once the appropriate function is displayed, changes can be made by pressing the (+) or (-) keys.

System Mode Flowchart

Information pertaining to each function is explained on the page listed next to the function name. Functions will appear in the same order they are shown on this chart.

Accessing the System Mode

1. Press the *Down* and *Channel* keys simultaneously.
2. Move the power switch to the On (upper) position.
3. Use either the *Up* or *Down* key to scroll through the menu and access the applicable function.

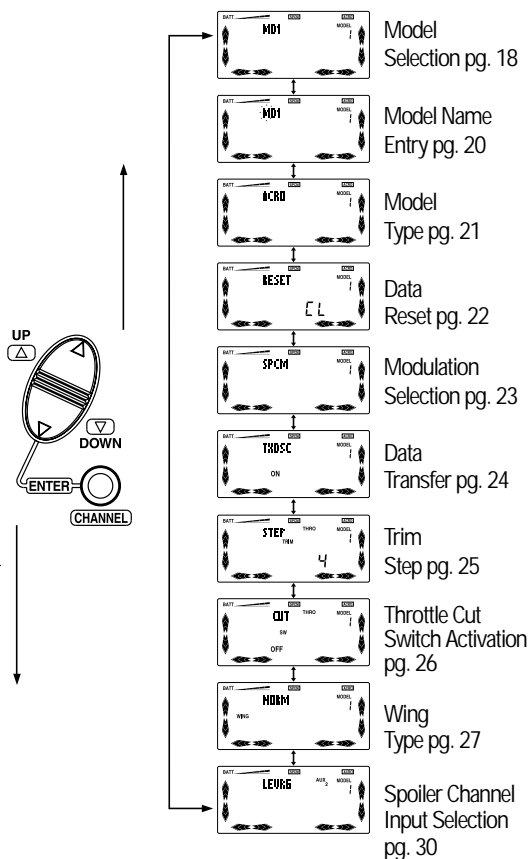

CHAPTER 5: SYSTEM MODE • Airplane

5.4 MODEL SELECTION/COPY SELECT

The X-378 system offers memory for eight completely separate models. Therefore, it is possible to have a mixture of helicopter, airplane and glider setups retained in memory. It is also recommended that the Model Name Entry function be used in conjunction

with each model setup. Another very useful function of the Model Selection function is the ability to set one aircraft up several different ways. This is helpful when multi-task performance is desired.

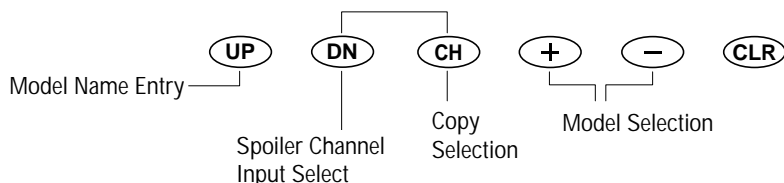
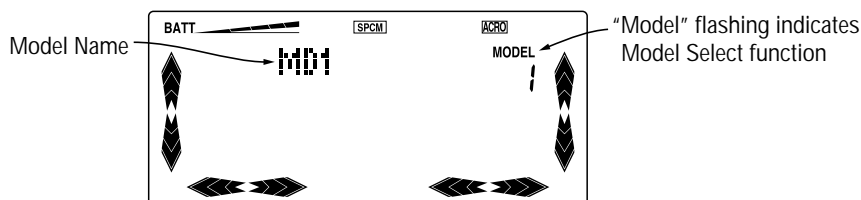

Accessing the Model Selection Function

1. While pressing the *Down* and *Channel* keys, switch the transmitter to the On position to enter the Model Setup mode.
2. Model should be flashing on the right top portion of the LCD. If not, press the *Up* or *Down* key until "Model" is displayed and flashing.
3. Pressing the (+) or (-) key will select among each of the eight models available. Notice that as each model is selected, its name appears in the left portion of the LCD.
4. To access the Copy Selection function, press the *Channel* key.
5. To access the Model Name Entry function, press the *Up* key.
6. Once the desired model is displayed on the left, pressing the *Down* and *Channel* keys simultaneously will exit the Model Selection function and establish the model displayed as the new current model.

Note: When changing from one model type to another, it is not necessary to use the Type Selection function. This is done automatically by the computer.

CHAPTER 5: SYSTEM MODE • Airplane

Copy Selection

The Copy Selection function enables you to copy all of the settings of the current model to another model within the same transmitter. This is very

useful when setting up one aircraft several different ways or when trying an alternative setup of your current model.

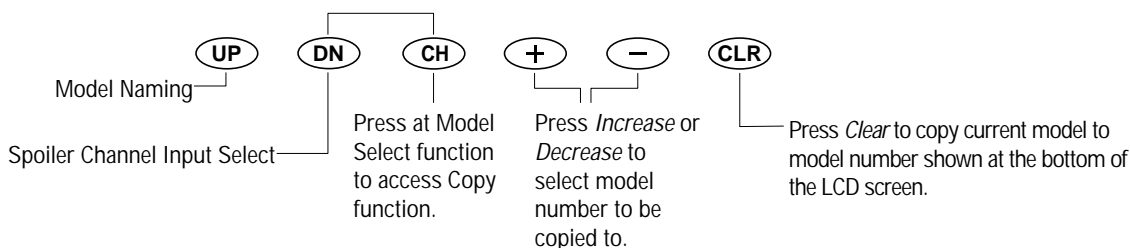
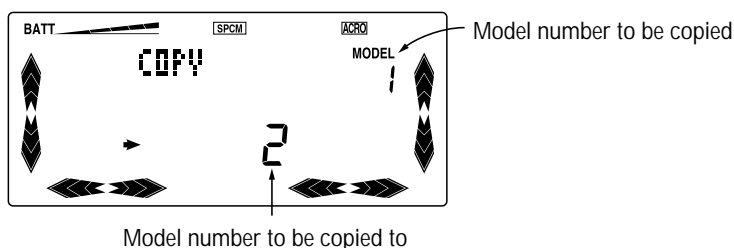

Accessing the Copy Selection Function

1. While pressing the *Down* and *Channel* keys, move the transmitter's power switch to the *On* position.
2. Press either the *Up* or *Down* key until "Model" appears flashing on the top right side of the LCD.
3. The number that appears below the flashing Model is the current model. This is important to note as only the current model will be the copied or "from" model. It is imperative to retrieve the proper current model prior to initiating the copy sequence. Press the *Increase* or *Decrease* keys to select the desired model to be copied.
4. Next, press the *Channel* key once. The word "Copy" will appear at the top left of the screen indicating that the Copy function has been selected.
5. The large number (1-8) at the bottom center of the LCD indicate the accepting model.
6. Now press the *Increase* or *Decrease* keys to select the accepting model number.

Note: Always make sure that the accepting model is either free of input or one which you no longer want to retain in your transmitter's memory. Once the copying process has been completed, the information of the accepting model is lost and the current model is input as the new data.

7. Once the desired accepting model is selected, press the *Clear* key to complete the Copy Selection function. The model number at the bottom of the screen will flash several times, indicating that the model copy function was successful. The "from" (template) model's name and data will now replace that of the accepting model.
8. To access the Spoiler Channel Input Select function, press the *Down* key.
9. To access the Model Naming function, press the *Up* key.
10. To exit the Copy Selection function, press the *Down* and *Channel* keys simultaneously.

CHAPTER 5: SYSTEM MODE • Airplane

5.5 MODEL NAME ENTRY

The X-378 allows a 3-digit name to be input for each of the eight models available. The current model will be displayed in the Normal display when the timer is

not active. You may also find this useful to identify different aircraft setups.

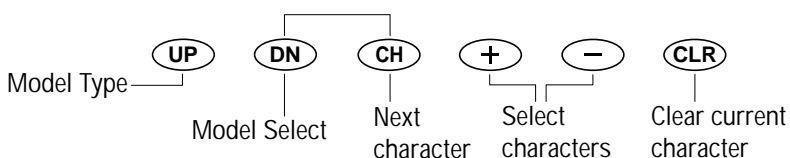
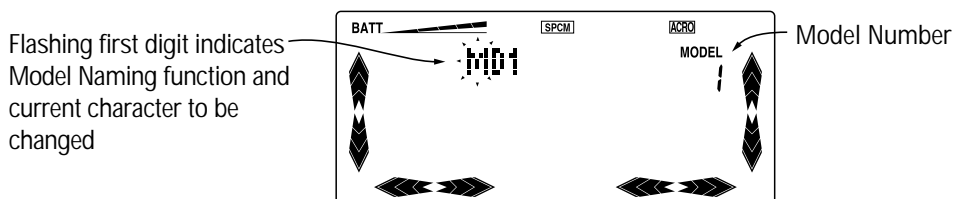

Accessing the Model Name Entry Function

1. While pressing the *Down* and *Channel* keys, switch the transmitter to the On (upper) position to enter the Model Setup mode.
2. Use the Model Selection function to select the model you want to name. (Please refer to the Model Selection section at this time.)
3. Press either the *Up* or *Down* key until the first digit of the model to be named is flashing on the left portion of the LCD.
4. The current name will be displayed in the left portion of the LCD. Pressing the (+) or (-) key will select the first alphanumeric character.

Note: The character being selected will flash.

5. Press the *Channel* key to advance the character selection to the next character.
6. Repeat this procedure until all three characters are selected.
7. To access the Model Selection function, press the *Down* key.
8. To access the Type Selection function, press the *Up* key.
9. To exit the Model Name Entry function, press the *Down* and *Channel* keys simultaneously.



CHAPTER 5: SYSTEM MODE • Airplane

5.6 MODEL TYPE SELECTION

The X-378 is capable of performing as a helicopter, airplane or sailplane radio with full functions for each.

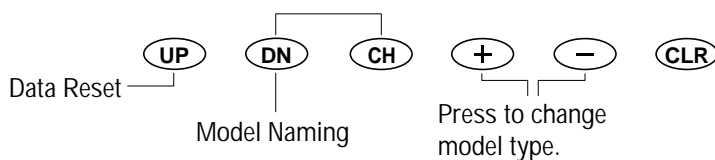
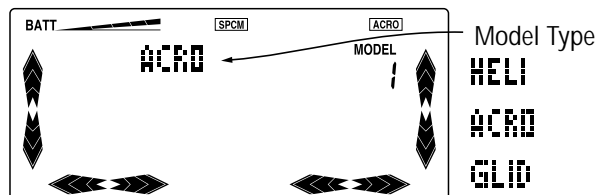

Accessing the Type Selection Function

1. While pressing the *Down* and *Channel* keys, switch the transmitter to the *On* position to enter the Model Setup mode.
2. Press either the *Up* or *Down* keys until "Acro," "Heli," or "Glid" is displayed in the left portion of the LCD.
3. Pressing either the (+) or (-) key will change the type of model.
4. To access the Model Name Entry function, press the *Down* key.
5. To access the Data Reset function, press the *Up* key.
6. To exit the Type Selection function, press the *Down* and *Channel* keys simultaneously.

CHAPTER 5: SYSTEM MODE • Airplane

5.7 DATA RESET

The Data Reset function permits you to reset all the functions and settings for the current model to factory conditions. Resetting does not affect the data already programmed for other models. Be sure to

confirm that you need to reset the data of the currently indicated model in order to prevent accidental loss of your valuable data.

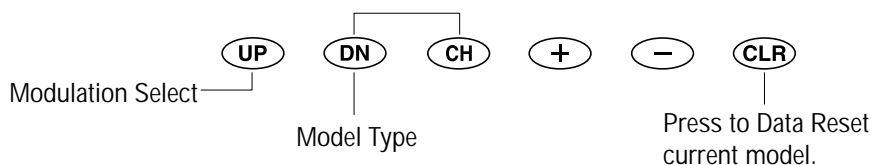
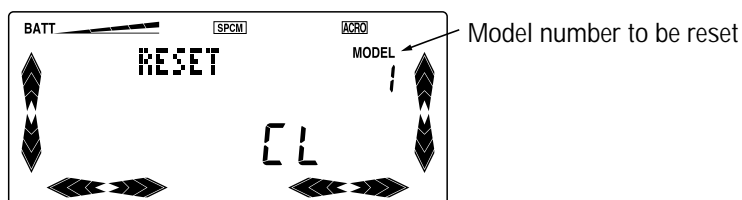

Accessing the Data Reset Function

1. While pressing the *Down* and *Channel* keys, switch the transmitter to the On position to enter the Model Setup mode.
2. Press the *Up* or *Down* key until "RESET" appears in the center of the LCD display. Be sure that the model selected is the model you want to reset by checking the number at the right side of the display.
3. To reset data, press the *Clear* key.
4. To access the Type Selection function, press the *Down* key.
5. To access the Modulation Selection function, press the *Up* key.
6. To exit the Data Reset function, press both the *Down* and *Channel* keys simultaneously.



CHAPTER 5: SYSTEM MODE • Airplane

5.8 MODULATION SELECT

The Modulation Selection function enables your X-378 to transmit to a variety of JR receivers that are already, or may soon be, in existence. You can select from either of two types of PCM, Z-PCM or S-PCM, depending on the Central Processing Unit (CPU)

within your receiver or from linear PPM (Pulse Position Modulation [FM]).

Refer to the receiver compatibility chart below for the correct modulation.

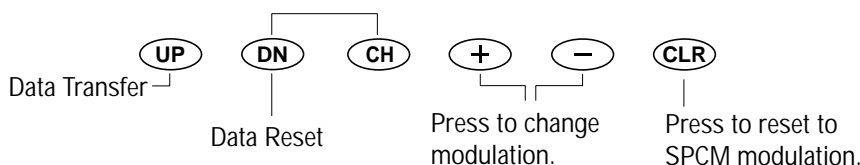
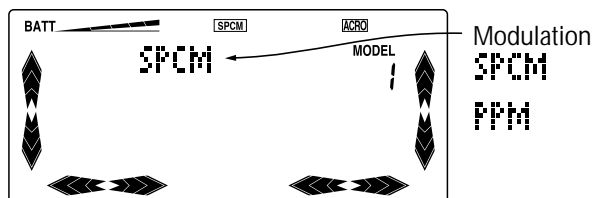

Accessing the Modulation Select Function

1. While pressing the *Down* and *Channel* keys, move the power switch to the On position to access the System mode.
2. Press either the *Up* or *Down* key until "SPCM," "ZPCM," or "PPM" appears at the top of the LCD.
3. To change among the modulation types, press either the (+) or (-) keys.

4. Pressing the *Clear* key will also reset the modulation selection to the factory preset S-PCM.
5. To access the Data Reset function, press the *Down* key.
6. To access the Data Transfer function, press the *Up* key.
7. To exit the Modulation Selection function, press the *Down* and *Channel* keys simultaneously.

Note: When the Data Reset function is used, the X-378 retains the current modulation selected for each model. This means that the modulation type does not change.

Note: In the normal display, the selected modulation type will appear in the middle of the LCD.

TX Modulation	Compatible Receivers	# of Channels & Brief Description	TX Modulation	Compatible Receivers	# of Channels & Brief Description
PPM	NER-226	6 (micro)	Z-PCM	NER-236	6 (micro)
PPM	NER-228	8	Z-PCM	NER-627XZ or 627 "G" series	7
PPM (FM)	NER-327x	7	Z-PCM	NER-J329P	9
PPM (FM)	NER-527x	7 (micro)	Z-PCM	NER-910XZ	10
PPM (FM)	NER-529x	9 (micro)	S-PCM	NER-955	10
PPM (FM)	NER-549	9	S-PCM	NER-D945	10
PPM	NER-600	6	S-PCM	NER-649S	9
PPM	NER-610M	6			
PPM	NER-700M	7			

CHAPTER 5: SYSTEM MODE • Airplane

5.9 DATA TRANSFER

The X-378's Data Transfer function allows for a model from one X-378 transmitter to be sent to another X378 transmitter by using a JR Trainer Cord (JRPA130 sold separately).

Transmitting Transmitter: It will first be necessary to select the desired model (1-8) to be transferred to the receiving transmitter. Access the Model Select function and select the desired model number to be transferred (see section 6.1 for information).

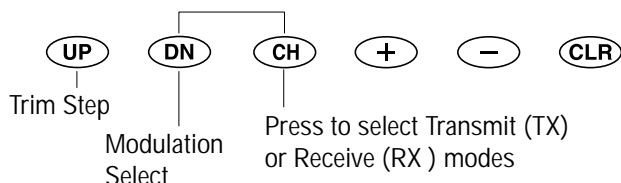
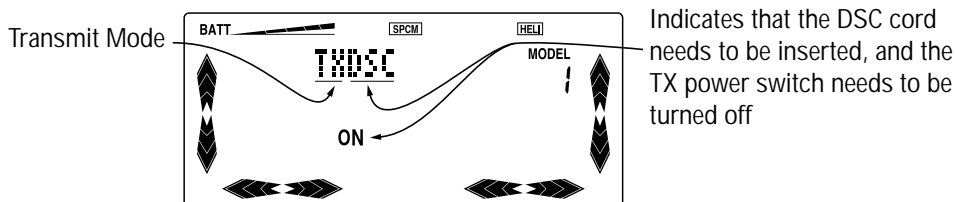

Transfer Procedure

- Both transmitters: With the main power switch off, press the *Down* and *Channel* keys simultaneously while turning the power switch on to enter the System mode. The word "TXDSC" will be displayed and flashing.
- Press the *Channel* key to select Transmit (TXDSC) or Receive (RXDSC) modes.
- Insert the Trainer cord into each transmitter, the letters DSC will be removed from the screen.
- Turn off the power switch on each transmitter. The screen will then change to read either "TXOUT" or "RXSEL", depending if transmit or receive modes were selected.
- (The transmitters will now be in System mode automatically)
- Press the *Channel* key to select transmit (TX) or receive (RX) modes.
- Both transmitters: In the System mode, press the *Up* or *Down* keys until the words "TXOUT" appears on the screen. This is the Data Transfer program.
- Receiving Mode Transmitter (TX to receive programming): Press the *Channel* key until the screen reads "RXSEL." The word "MODEL" will begin flashing at the top right portion of the LCD directly over the current model number selected.
- Select the receiving model number by pressing the (+) and (-) keys.

Note: It is also possible to access the Data Transfer function as follows:

- With the main TX power switch off, press the *Down* and *Channel* keys simultaneously while inserting the trainer cord into the DSC jack of both transmitters.



CHAPTER 5: SYSTEM MODE • Airplane

5.10 TRIM STEP

The Trim Step function allows the user to increase or decrease the coarseness of the servo movement as compared to the steps or beeps of the digital trim. The total servo trim movement remains the same, (approx. 30degree) regardless of the trim step rate selected (1~10). The factory default setting for the trim step function is 4, which means that for each

step (beep) of the digital trim, the servo will move in digital increments of 4. In other words, if a finer trip step value of 1 is selected, the servo will move in a digital increment of 1 for each step (beep) of the digital trim. If a more coarse trim value of 10 is selected, the servo will move in a digital increment of 10 for each step (beep) of the digital trim lever.

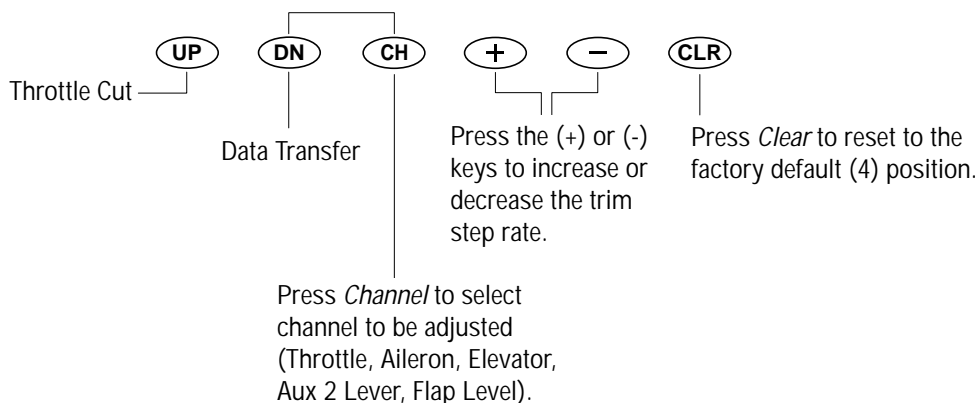
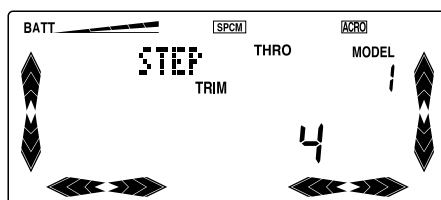

CHAPTER 5: SYSTEM MODE • Airplane

5.11 THROTTLE CUT SWITCH ACTIVATION

This is the function to assign Throttle Cut switch to the push button located on upper front of the transmitter. In the System mode, select the Throttle Cut Switch function (CUT) by using *Up* or *Down* keys, and press (+) or (-) keys to select the function on or

off. The Throttle Cut function is designed to return the throttle trim to the lowest position instantly and keep this position while the button is pressed. This feature is used to “cut” or stop the engine without changing the position of digital throttle trim.

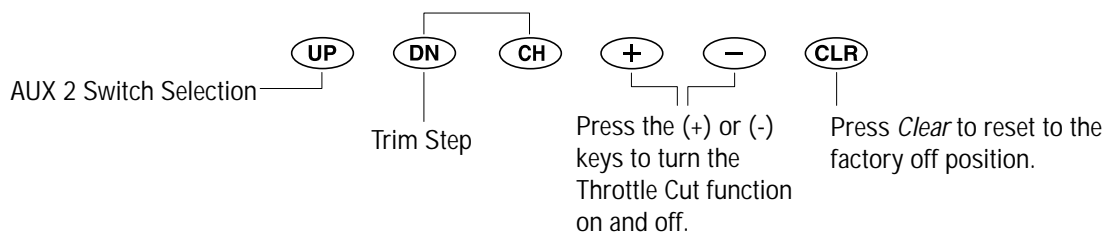
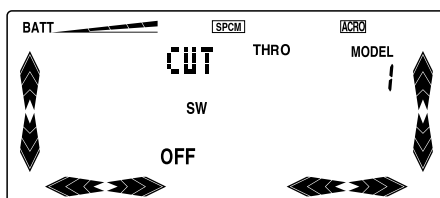

CHAPTER 5: SYSTEM MODE • Airplane

5.12 WING TYPE SELECTION

The purpose of the Wing Mixing or Wing Type function is to eliminate mechanical or programmable mixes that would otherwise be necessary for the proper flight of certain styles of aircraft. There

are three wing types from which to choose; select the one that will best suit your R/C aircraft. They are as follows: Normal, Flapperon, and Elevon (Delta). Each of the Wing Type selections will be covered below.

Normal Wing Type Selection

This is the first wing type selection that appears on your LCD display. Use this wing type with common aircraft that utilize only one servo for both of the control surfaces. Normal is the factory default setting for the Wing Mixing function. This means that if data

reset is performed, your radio will return to this wing type selection. Your X-378 transmitter will also return to the normal wing mixing type if the transmitter battery pack and the lithium battery are both removed from the transmitter.

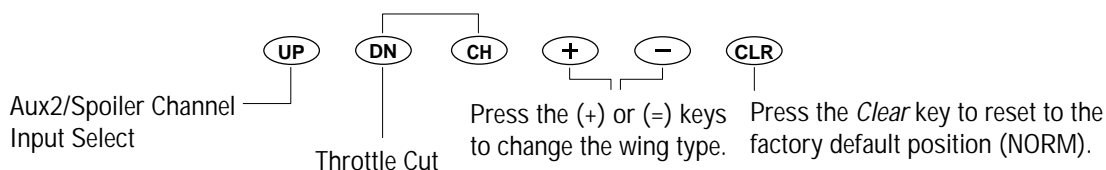
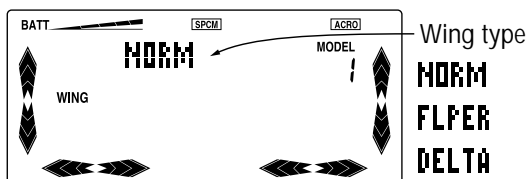

Accessing the Normal Wing Mixing Selection

1. While the *Down* and *Channel* buttons are pressed, move the power switch to the On position to access the System mode.
2. Press either the *Up* or *Down* key until "WING" appears at the left portion of the LCD. The current wing type will be displayed on the upper center portion LCD: NORM-Normal; FLPER-Flapperon; DELT-Delta (Elevon).
3. Press either the (+) or (-) key to select the desired wing type.
4. To access the Throttle Cut function, press the *Down* key.
5. To access the Aux2/Spoiler Channel Input Select function, press the *Up* key.
6. To exit the Wing Mixing function, press the *Down* and *Channel* keys simultaneously.

Note: There are not any special receiver port connections to be made when the Normal Wing Type Selection is selected.



CHAPTER 5: SYSTEM MODE • Airplane

Flapperon Wing Type Selection

Flapperons allow you to use the existing ailerons as flaps. The ailerons can be raised or lowered in

unison as flaps, yet still remain fully operational as the ailerons of your R/C airplane.

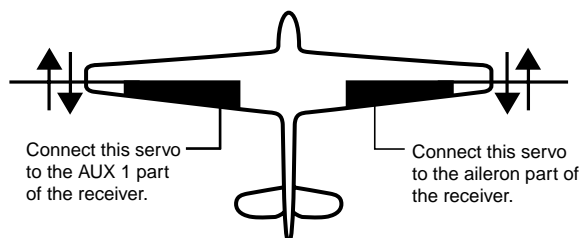

Accessing and Utilizing the Flapperon Wing Type Selection

1. While the *Down* and *Channel* buttons are pressed, move the power switch to the On position to access the System mode.
2. Press either the *Up* or *Down* keys until "WING" appears in the left portion of the LCD. The current wing type will be displayed on the Upper center portion of the LCD: Norm-Normal; FLPER-Flapperon; DELT-Delta (Elevon).
3. Press either the (+) or (-) key to access the Flapperon (FLPR) Wing Type Selection.

Note: For Flapperon, one servo must be used for each aileron control surface.

4. Plug the left wing aileron servo into the Auxiliary 1 (AUX 1) port of your JR receiver. Connect the right aileron servo into the aileron port (AILE) of your receiver.
5. Check to make sure that the wing servos move in the proper direction. For a right turn, the right aileron should raise while the left aileron lowers simultaneously. For a left turn, the opposite is true; the left aileron should rise while the right aileron drops. If your servos are not moving in the direction just described, use the Servo Reversing function to reverse the travel direction of the servo(s) that are moving improperly. Refer to the Servo Reversing section for information on how to reverse the travel direction.

Note: Each servo's travel direction is adjusted individually through the Servo Reversing function.

Once the servos achieve their proper travel direction, adjust their travel volume, dual rates, sub-trim and aileron differential.

Note: The applicable channel's left or right travel adjustment may be made individually by accessing the Travel Adjust function. Refer to the Travel Adjust section of this manual for more information. The fine adjustments of your aileron controls should be made in the Dual-Rate function. Refer to the Dual-Rate section for information on how to do so. You can also adjust the neutral point of your aileron servos individually through the use of the Sub-Trim function. Refer to the Sub-Trim section of this manual for more information.

6. The flap lever located on the right face of the transmitter controls the aileron movements as flaps.

Note: Differential is offered for the Flapperon function of your X-378. For more information, please refer to the Differential section of this manual.

8. To access the Throttle Cut function, press the *Down* key.
9. To access the Aux2/Spoiler Channel Input Select function, press the *Up* key.
10. To exit the Wing Mixing function, press the *Down* and *Channel* keys simultaneously.



CHAPTER 5: SYSTEM MODE • Airplane

Delta Wing Type Selection

Delta or Eleveon is the final Wing Mixing selection in your X-378. This style of aircraft also employs two wing servos. However, there is not an elevator present. Instead, at an elevator stick input, the two wing servos function in conjunction with one another to create an up/down movement of the aircraft. The

wing itself functions as if it were the elevator. Also, when an aileron control is given, the two wing servos move in opposition to one another to function as ailerons.

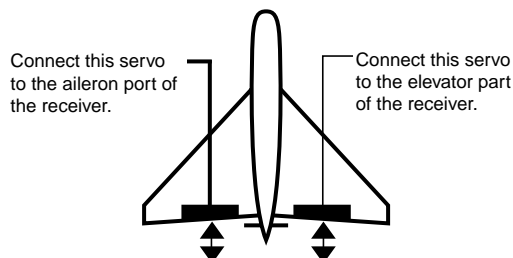

Delta Wing Type Selection

1. While the *Down* and *Channel* keys are pressed, move the power switch to the On position to access the System mode.
2. Press either the *Up* or *Down* key until "WING" appears in the left portion of the LCD. The current wing type will be displayed on the upper center portion of the LCD: NORM-Normal; FLPER-Flapperon; DELTA-Delta (Eleveon).
3. Press either the (+) or (-) key to select the Delta (Eleveon) Wing Type function.

Note: With the Delta function, one servo must be used for each eleveon, i.e., a separate servo for each wing half.

4. Plug the left eleveon servo to the aileron (AILE) of your JR receiver. Connect the right eleveon servo into the elevator (ELEV) port of your receiver.
5. Check to make sure that the servos move in the proper direction. When an input is given from the elevator stick, they should move in unison to achieve the proper up/down elevator command. If your servos do not move in the proper direction as described above, use the Servo Reversing function to reverse the travel direction.

Note: Each servo's direction is adjusted individually through the Servo Reversing function. For more information, refer to the Servo Reversing section in this manual.

6. Once the servos have achieved their proper travel direction, adjust their travel volume, dual rates, sub-trim and aileron differential.

Note: The applicable channel's left or right, up or down travel adjustments can be made individually. Refer to the Travel Adjust section in this manual for more information.

7. Relative to the note above, each servo's travel volume is automatically reduced to 75% of the operating range. This is to ensure that the servo does not operate beyond its capabilities. Failure to observe extreme caution when adjusting the value for the eleveon servos may result in damage to the servos by over traveling.

Note: Fine adjustments of the eleveons should be made in the Dual-Rate function. For more information, refer to the Dual-Rate section in this manual. You can also adjust the neutral point of your eleveon servos individually. To do so, use the Sub-Trim function as described in the Sub-Trim section of this manual. Differential is offered for the eleveon function of your XP-783. For more information, refer to the Differential Aileron Mixing section of this manual.

9. To access the Throttle Cut function, press the *Down* key.
10. To access the Aux2/Spoiler Channel Input Select function, press the *Up* key.
11. To exit the Wing Mixing function, press the *Down* and *Channel* keys simultaneously.



CHAPTER 5: SYSTEM MODE • Airplane

5.13 AUX 2/SPOILER CHANNEL INPUT SELECT

The purpose of the Aux 2/Spoiler Channel Input Selection function is to assign the activation device for the AUX 2 channel. The Lever provides proportional control, while the switch allows On/Off function of the AUX 2 channel.

Note: If the spoiler is coupled to the landing system, the spoiler lever or switch will not operate the spoiler's channel and "LAND" will appear in this program.

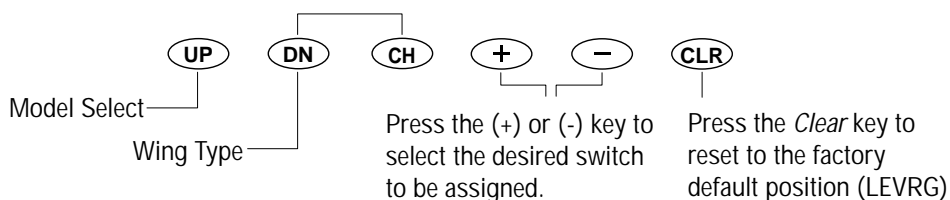
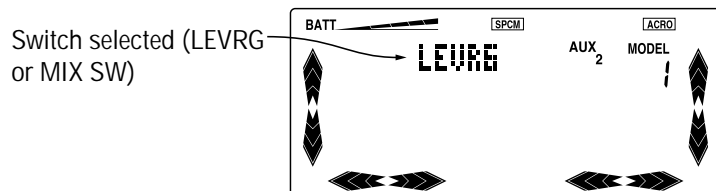

Accessing the Spoiler Channel Selection Function

1. While pressing the *Down* and *Channel* keys, switch the transmitter to the On position to enter the System Mode.
2. Press either the *Up* or *Down* key until "AUX 2" appears at the upper right portion of the LCD.
3. Press either the (+) or (-) key to assign the desired switch (LEVRG or MIX SW)
4. To access the Wing Type function, press the *Down* key.
5. To access the Model Select function, press the *Up* key.
6. To exit the Aux2/Spoiler Channel Input Selection function, press the *Down* and *Channel* keys simultaneously.



CHAPTER 6: FUNCTIONS (FUNCTION MODE) • Airplane

6.1 FUNCTION MODE

To enter the Function mode, switch the transmitter power switch to the On position. Press the *Down* and *Channel* keys simultaneously, and the display will show the last active program. Pressing either the *Up* or *Down* key then scrolls through the functions one by one, according to the Function Mode Flowchart shown on the right. Once the appropriate function is displayed, changes can be made by pressing the (+) or (-) keys. To select another channel of a particular function, press the *Channel* key. If you transfer to a different function that is channel selectable, the display will show the same channel. For example, if you are adjusting the dual rate of the elevator and you change to the Exponential function, the channel remains elevator. The Function mode is the most often used system to input data.

Function Mode Flowchart

Information pertaining to each function is explained on the page listed next to the function name. Functions will appear in the same order they are shown on this chart.

Accessing the Mode Function

1. Move the power switch to the On position.
2. Press the *Down* and *Channel* keys simultaneously.
3. Use either the *Up* or *Down* to scroll through the menu and access the applicable function.

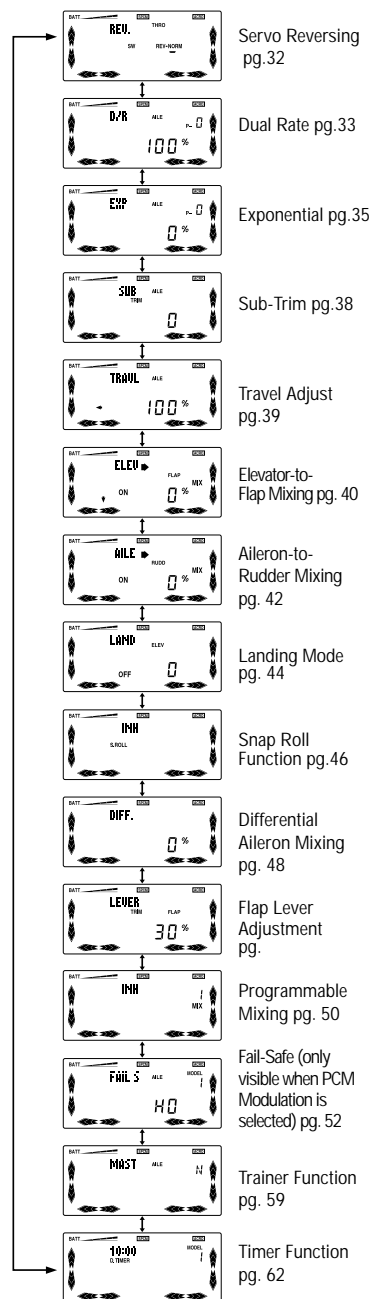
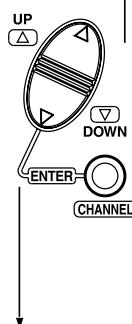

CHAPTER 6: FUNCTIONS (FUNCTION MODE) • Airplane

6.2 SERVO REVERSING

The Reverse Switch function is an electronic means of reversing the throw of a given channel (servo). All seven channels of the X-378 offer reversible servo

direction. This will ease setup during the servo installation into your aircraft.

THRO: Throttle
 AILE: Aileron
 ELEV: Elevator
 RUDD: Rudder
 GEAR: Retract
 Landing Gear
 FLAP: Flap (AUX 1)
 SPOI: Spoiler

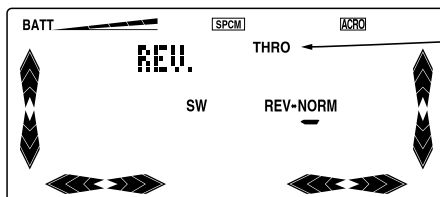

Channel to be adjusted

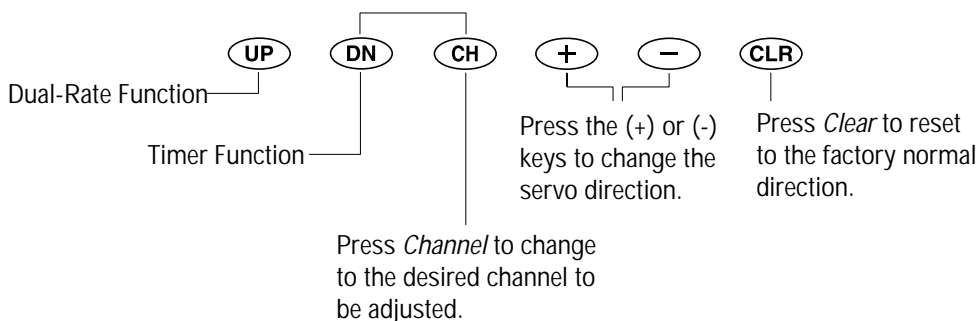

Accessing the Reverse Switch Function

1. Place the transmitter switch in the on position.
2. Access the Function mode by pressing the *Down* and *Channel* keys simultaneously.
3. Press either the *Up* or *Down* key until the "REV." appears in the upper left corner of the LCD.
4. Using your transmitter's control sticks, switches and potentiometers, move the control surfaces of your aircraft. Note the travel direction of each of the corresponding control surfaces.
5. After you have determined which channel(s) need to have the throw directions reversed, use the *Channel* key to call up the appropriate channel.
6. Press either the (+) or (-) keys to change the travel direction of the servo. Pressing the *Clear* key returns the travel direction to Normal.
7. You can observe the change in the travel direction by moving the appropriate control at this time.
8. To access the Timer function, press the *Down* key.
9. To access the Dual Rate function, press the *Up* key.
10. To exit the Reverse Switch function, press the *Down* and *Channel* keys simultaneously.



CHAPTER 6: FUNCTIONS (FUNCTION MODE) • Airplane

6.3 DUAL RATES

Dual rates are available for the aileron, elevator and rudder channels of your R/C aircraft. There is also an automatic dual rate setting to link your aileron, elevator, and rudder dual rates to the flight model switch. This automatic Dual-Rate function is discussed in a separate section that follows. Dual rates may be defined as the ability to vary the travel or throw rate of a servo from a switch. Due to the differing travel rates, you will find that the sensitivity

of the control either increases or decreases accordingly. A higher rate, or travel, yields a higher overall sensitivity. You may find it easier to think of the Dual-Rate function as double-rates or half-rates. The Dual-Rate function works in conjunction with the Exponential function to allow you to precisely tailor your control throws. You may want to consult the section defining exponential for further information.

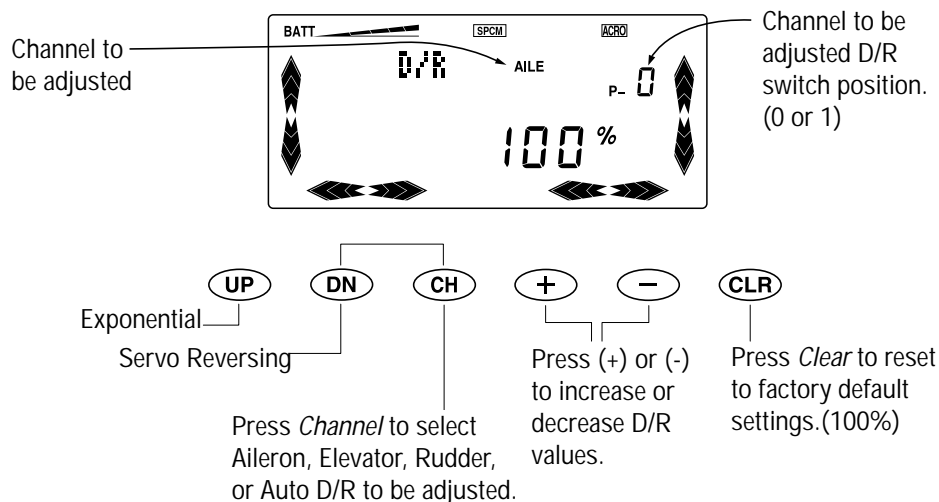

The amount of travel is adjustable from 0-125% in 1% increments. The factory setting, or default value, for both the 0 and 1 switch positions is 100%. Either

switch position may be selected as the low or high rate by placing the switch in the desired position and adjusting the value accordingly.

Accessing the Dual-Rate Function

1. Place the transmitter power switch in the on position.
2. Access the Function mode by pressing the *Down* and *Channel* keys simultaneously.
3. Press either the *Up* or *Down* key until "D/R" appears in the upper left corner of the LCD.
4. Press the *Channel* key until the desired channel (aileron, elevator, rudder or automatic dual rates) appears.
5. Select the switch position for which you want to adjust the rate. The number to the upper right of the current rate value on the display indicates the current position of the Dual-Rate switch for the

channel that you have selected. Either a 0 or a 1 will be shown, corresponding to the position of the switch. To select the opposite switch position, move the appropriate Dual-Rate switch to the opposite position. The number that appears above the current rate value reflects the change.

6. Adjust the rate for the channel and the switch position that you have just selected. To decrease the throw rate, press the (-) key. To increase the throw rate, press the (+) key. As stated previously, the adjustable rate is from 0-125% for each switch position and channel.

CHAPTER 6: FUNCTIONS (FUNCTION MODE) •

Accessing the Dual-Rate Function (continued)

Note: You can observe the servo changes by moving the respective stick while increasing or decreasing the values. The control changes accordingly. To clear the dual rate for the respective channel and switch position, press the *Clear* key. After the dual rates have been dialed in to your satisfaction, we suggest that you begin to adjust the exponential values. Refer to the Exponential section for more information.

7. To access the Servo Reversing function, press the *Down* key.
8. To access the Exponential function, press the *Up* key.
9. To exit the Dual-Rate function, press the *Down* and *Channel* keys simultaneously.

Automatic Dual-Rate

If the Automatic Dual-Rate function AUTO is active (on), when switching the flight mode switch, aileron,

elevator and rudder channel Dual-Rate values are switched to preset values settled by position 1.

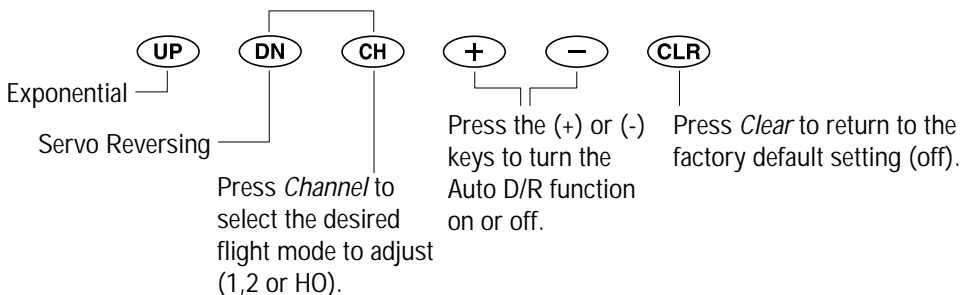
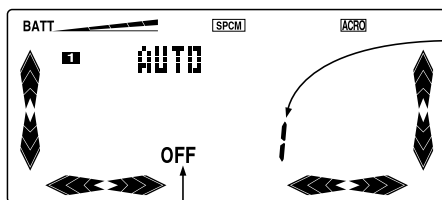

To access this function, move to the D/R (Dual-Rate) screen, and press the *Channel* button until the word "AUTO" appears at the top center of the screen, with a small box with the number 1 to the far left. This would indicate the Auto D/R function for Flight mode 1. Press the (+) or (-) keys to turn the function on or off. Repeat this procedure for flight modes 2 and

Hold (HO). To confirm that the Auto D/R is functioning, simply move the flight mode switch while at any of the normal D/R channel screens. If the Auto D/R is functioning, the screen will indicate D/RAT, and the D/R switch position at the far right of the screen will change from 0 to 1 as the switch is moved.

CHAPTER 6: FUNCTIONS (FUNCTION MODE) • Airplane

6.4 EXPONENTIAL

Programmable exponential adjustments are offered on the aileron, elevator, and rudder channels of your R/C aircraft. Exponential is a function that allows you to tailor the response rate of the stick controls. The purpose of exponential is to reduce the sensitivity in the middle portion of stick movement, while still allowing full travel at the end of the stick movement. In other words, the end result (travel) remains the same, although exponential changes the rate at which it achieves this travel.

The adjustable range of the Exponential Function is from 0-100%. Zero percent (0%) is linear stick control

which means that the response rate is equal throughout the stick control. 100% is full exponential. The larger the exponential value, the less servo action or sensitivity you will notice around the neutral setting.

Note: The Exponential function operates in conjunction with the Dual-Rate function. It is imperative to understand the Dual-Rate function prior to adjusting the exponential values. Exponential may be selected for either the high or low rate or both.

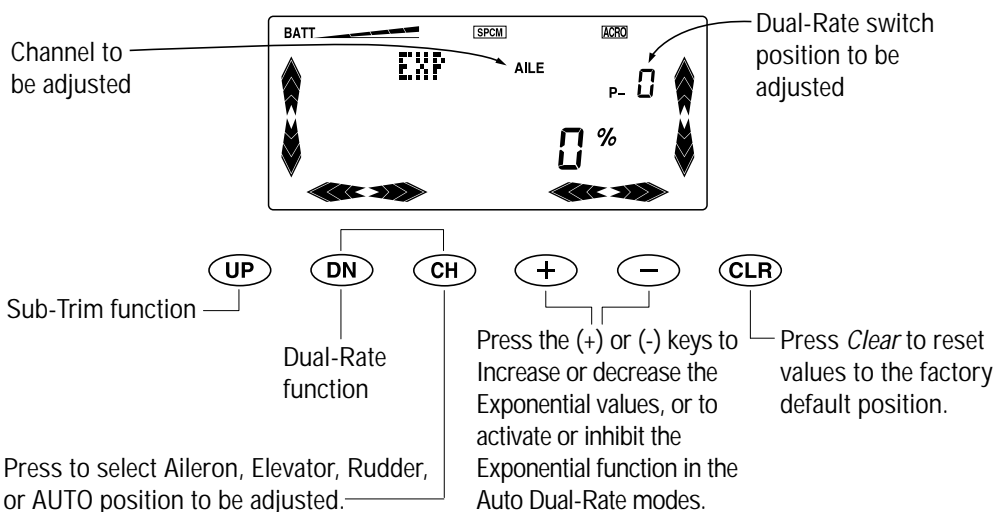

Accessing the Exponential Function

1. Place the transmitter power switch in the On position.
2. Press the *Down* and *Channel* keys simultaneously to access the Function mode.
3. Press either the *Up* or *Down* key until "EXP" (Exponential) appears in the upper left corner of the LCD.
4. Press the *Channel* key until the desired channel (aileron, elevator, rudder or AUTO) appears.
5. Select the switch position for which you want to adjust the exponential rate. The number directly above the exponential value on the display indicates the current position of the Dual-Rate switch for the channel that you have selected. Either a 0 or 1 will be shown, corresponding to the position of the switch. To select the opposite switch position, move the appropriate Dual-Rate or Flight mode switch to the opposite position. The number that appears directly

above the Exponential value will reflect the change.

6. Adjust the rate for the channel and the switch position that you have just selected. To increase the exponential rate, press the (+) key. The adjustable rate is from linear (0%) to 100% for each switch position and channel.

Note: Exponential is an acquired feel. It may take several test flights to achieve the proper amount of exponential that fits your flying style.

8. To access the Dual-Rate function, press the *Down* key.
9. To access the Sub-Trim function, press the *Up* key.
10. To exit the Exponential Function, press the *Down* and *Channel* keys simultaneously.



CHAPTER 6: FUNCTIONS (FUNCTION MODE) • Airplane

Automatic Rudder Exponential Rate

When the Automatic Rudder Exponential Rate function is active, the throttle stick position will automatically switch among the rudder exponential rates that you have selected in the exponential section listed above. This means that, as you advance or pull back the throttle stick, the rudder exponential rates automatically change. When the throttle stick is moved anywhere from low to approximately 70% of full travel, the low (position 0) rudder exponential rates are active; once the throttle is fully advanced, high (position 1) rudder exponential will automatically return.

You will find that the automatic rudder exponential rate is very useful in overcoming special flying problems. The idea is to have less rudder sensitivity at high throttle positions because the rudder is more effective at higher speeds. Conversely, it is more efficient to have more rudder sensitivity at lower speeds because the rudder is not as effective. The Automatic Rudder Exponential Rate function can also be used in the opposite manner to reduce the sensitivity of the rudder for takeoffs with models that have sensitive steering.

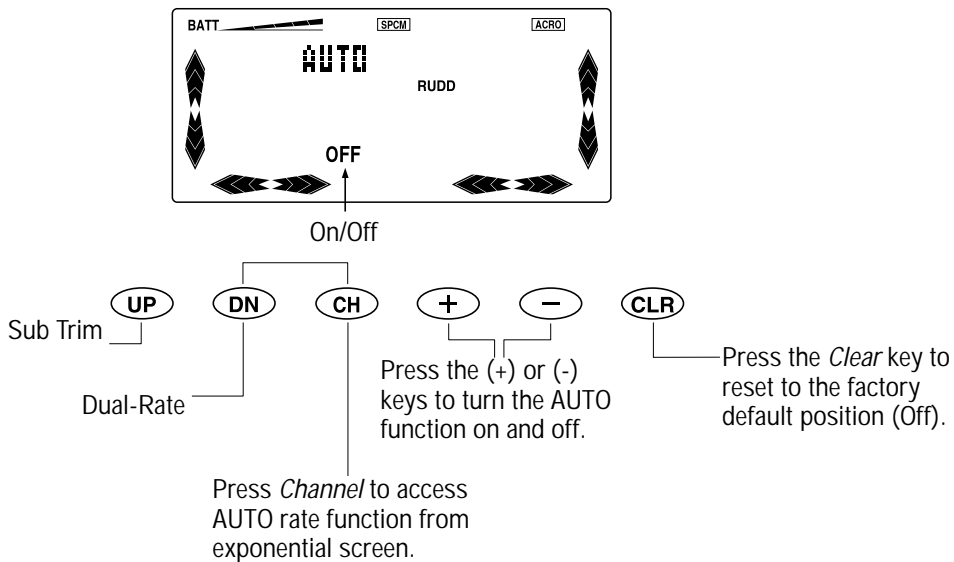

CHAPTER 6: FUNCTIONS (FUNCTION MODE) • Airplane

Adjusting the Automatic Rudder Exponential Rates

1. Place the transmitter switch in the On (upper) position.
2. Access the Function mode by pressing the *Down* and *Channel* keys simultaneously.
3. Press either the *Up* or *Down* key until "D/R" appears in the upper center portion of the LCD.
4. Press the *Channel* key until "AUTO" is displayed.
5. Pressing either the (+) or (-) keys changes the automatic rudder Exponential rate from off to on. To return the auto rudder exponential rate to the "Off" position, press the (+) or (-) keys one more time or press the *Clear* key.
6. When the Automatic Rudder Exponential Rate function is active, "EXPAT" will be displayed on the rudder exponential rate display.
7. The exponential rate value selected for switch position 0 will be the value used for low throttle stick operation (Up to approximately 70%); the exponential rate value selected for switch position 1 will be the exponential value used when the throttle stick is in the high (full) position.
8. To access the Dual-Rate function, press the *Down* key.
9. To access the Sub Trim function, press the *Up* key.
10. To exit the Automatic Rudder Exponential Rate function, press the Down and Channel keys simultaneously.

Note: In order for the Automatic Rudder Exponential Rate function to operate, the rudder dual rate switch must be in the 0 position. Moving the dual rate switch to the 1 position negates the operation of the automatic rudder exponential rate and defaults the rate to the value for switch 1.

To confirm that the Auto Rudder Exponential Rate is functioning, simply move the throttle stick while at the EXPAT screen. If the Auto Rudder Exponential is functioning, the exponential rate switch position at the far right of the screen will change from 0 to 1 as the throttle stick is moved.

CHAPTER 6: FUNCTIONS (FUNCTION MODE) • Airplane

6.5 SUB-TRIM

The Sub-Trim Adjustment function allows you to electronically fine-tune the centering of your servos. Individually adjustable for all seven channels with a range of $\pm 125\%$ (± 30 degrees servo travel), the sub-trims can be set for the same neutral settings for

each model stored in the transmitter's memory. The sub trim functions provides precise servo arm neutral positioning if rotating the servo arm will not allow the desired servo arm position.

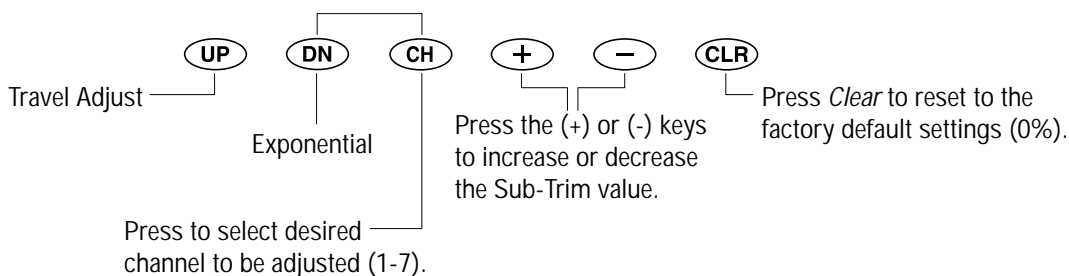
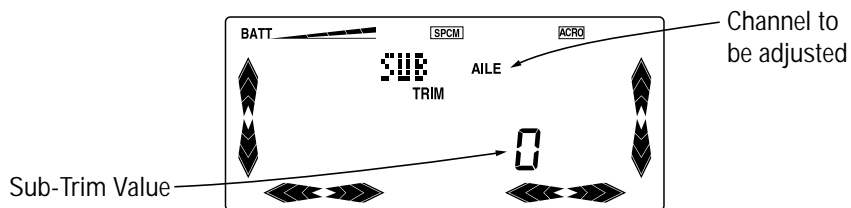

Accessing Sub-Trim Adjustment Function

1. Place the transmitter power switch in the On position.
2. To Access the Function mode, press the *Down* and *Channel* keys simultaneously.
3. Press either the *Up* or *Down* key until "SUBTRIM" appears in the upper middle portion of the LCD.
4. Press the *Channel* key until the desired channel appears.
5. Press the (+) or (-) key to establish the desired amount and direction of Sub-Trim.

Note: A (+) or (-) symbol appears to the left of the sub trim value to indicate the direction of Sub-Trim input.

Caution: Do not use excessive sub-trim adjustments since it is possible to overrun your servo's maximum travel if it is off-center. Remember that it is a trim convenience function. It is not intended to take the place of the proper mechanical trim adjustments that are necessary on any R/C model. An offset servo will also produce a differential effect.

6. To access the Exponential function, press the *Down* key.
7. To access the Travel Adjust function, press the *Up* key.
8. To exit the Sub-Trim function, press the *Down* and *Channel* keys simultaneously.



CHAPTER 6: FUNCTIONS (FUNCTION MODE) • Airplane

6.6 TRAVEL ADJUST

The purpose of Travel Adjust, also known as endpoint adjustment or adjustable travel volume, is to offer you precise servo control deflection in either direction of servo operation. The X-378 offers travel adjust for all seven channels. The Travel Adjust range

is from 0-150% (0 degrees to 60 degrees) from neutral, or center, and it can be adjusted for each direction individually. The factory default (Data Reset) value is 100% for each direction of servo travel.

Travel direction to be adjusted (left/right, up/down, etc)



Channel to be adjusted

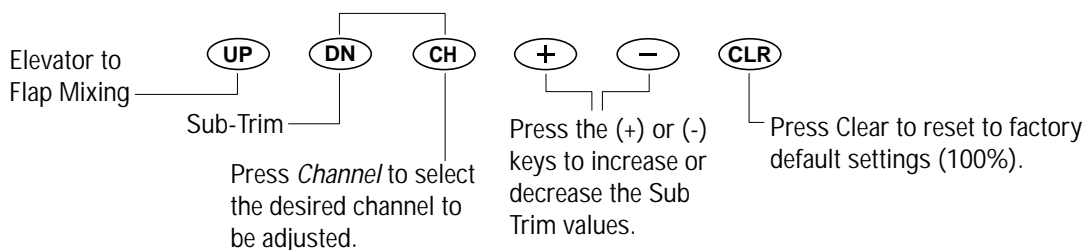

Accessing the Travel Adjust Function

1. Place the transmitter power switch in the On position.
2. Access the Function mode by pressing the *Down* and *Channel* keys simultaneously.
3. Press either the *Up* or *Down* key until "TRAVL" appears in the upper middle portion of the LCD.
4. Press the *Channel* key until the desired channel appears.
5. Move the appropriate control stick (lever, switch, etc) to the right or left of center to the direction of travel you want to adjust. An arrow to the right of the travel adjust value will reflect the current position to be adjusted. Using our example above, if the aileron stick is moved to the left, a left-facing arrow will appear to the left of the travel adjust value on the LCD screen.
6. After the control stick or switch is placed in the direction of travel to be adjusted, press the (+) or (-) key until the proper amount of servo travel is shown on the lower right side of the LCD. Press the (+) key to increase the amount of servo travel. Press the (-) key to decrease the amount of servo travel.
7. Follow the same procedure for the remaining channels.
8. To access the Sub-Trim function, press the *Down* key.
9. To access the Throttle Hold (or CCPM Mix if activated) function, press the *Up* key.
10. To exit the Travel Adjust function, press the *Down* and *Channel* keys simultaneously.



CHAPTER 6: FUNCTIONS (FUNCTION MODE) • Airplane

6.7 ELEVATOR-TO-FLAP MIXING

When this system is active and a value of flaps is input, the flaps will be deflected each time the elevator stick is used. The actual flap movement is adjustable for both up and down elevator. The most frequently used application is up elevator/down flaps

and down elevator/up flaps. When used in this manner, the aircraft pitches much more quickly than normal. The upper-most position of the Flap Mixing switch activates the Elevator-to-Flap Mixing circuitry.

Up/Down arrows change when the elevator stick is moved, and indicate current position to be adjusted

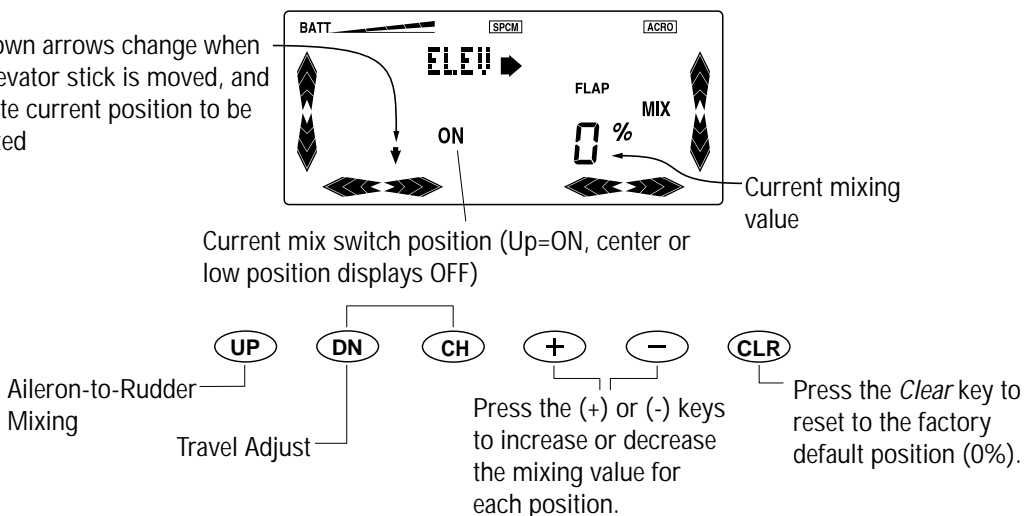

Accessing the Elevator to Flap Mixing Function

1. Place the transmitter power switch in the On position.
2. Access the Function mode. To do so, press the *Down* and *Channel* keys simultaneously. Press either the *Up* or *Down* key until "ELEV-FLAP" appears in the center portion of your LCD.

Note: If the Flap Mixing switch is not in the uppermost position, the position indicator will read "OFF". The flap mixing switch must be in the upper (elevator) mix position in order to make adjustments to the flap mixing value.

3. Move the elevator stick in the direction you want to mix with flaps.

Note: The position indicator will reflect this change by replacing the up arrow with a down arrow or vice-versa. A down arrow indicates up elevator, and an up arrow indicates down

elevator (arrow position is indicating stick position, not elevator direction).

5. Press the (+) or (-) key to increase or decrease the amount of flaps to be mixed. If you want to reverse the flap travel, press the *Clear* key, bringing the mixing value to the factory default (0%), and increase the value using the opposite key (+) or (-) from the key originally selected.
6. Once you have adjusted the first mixing position (up or down), place the elevator stick in the opposite direction and follow Step 5 above to adjust the second elevator mixing value.
7. To access the Travel Adjust function, press the *Down* key.
8. To access the Aileron-to-Rudder Mixing function, press the *Up* key.
9. To exit the Elevator-to-Flap Mixing function, press the *Down* and *Channel* keys simultaneously.

CHAPTER 6: FUNCTIONS (FUNCTION MODE) • Airplane

Note: Only the elevator input indicated by the LCD will be cleared. For example, if the up arrow were displayed and *CLR* were pushed, the down arrow value would still be retained by the transmitter. In order to change elevator operating direction, move the elevator control stick in the direction you want to mix with flaps. Using our example, we would input down elevator. The down arrow would be displayed at the lower left

portion of the LCD. Our mixing value would also change to reflect our input. If the Flap Mixing switch is not in the uppermost position, the position indicator will change from "On" to "Off". This indicates that the Elevator-to-Flap Mixing function is not currently active. Although the current mixing value will still be displayed, it will not be possible to alter this value until the mix switch is returned to the on position.



CHAPTER 6: FUNCTIONS (FUNCTION MODE) • Airplane

6.8 AILERON-TO-RUDDER MIXING

This form of mixing is designed so that when input to the aileron stick is given, the rudder servo will also move, eliminating the need to coordinate these controls manually.

When adjusting, if an opposite mixing direction of the rudder servo is required, simply press the (+) or (-) keys to change the mixing value from a (+) to (-)

or a (-) to a (+). This will reverse the mixing direction of the rudder from its original direction. The switch used to activate this mix can also be selected as explained below. The factory default mix switch for the Aileron-to-Rudder mix function is Rudder D/R/Mix switch located at the upper right side of the transmitter.

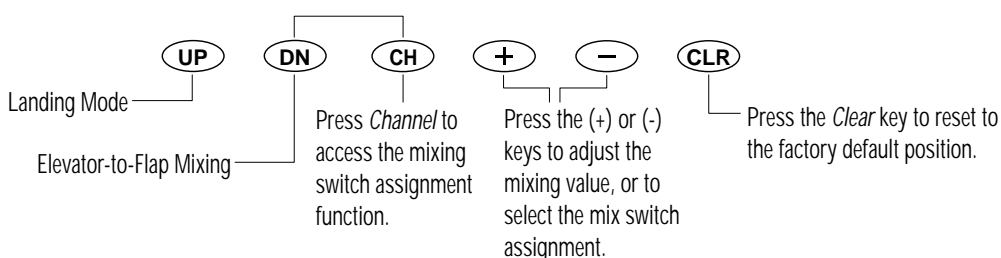
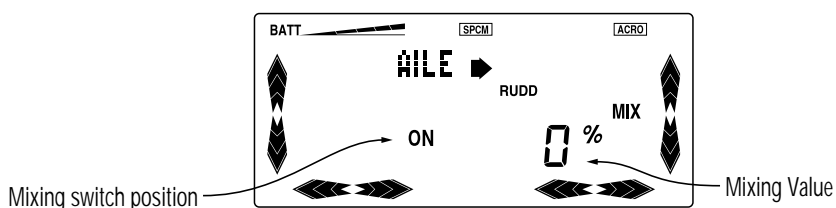

Accessing the Aileron-to-Rudder Mixing Function

1. Place the transmitter power switch in the On position.
2. Access the Function mode. To do so, press the *Down* and *Channel* keys simultaneously. Press either the *Up* or *Down* key until "AILE-RUDD" appears in the center portion of your LCD.

Note: If the current mixing switch is not in the on position, the position indicator will read "OFF." The current mixing switch must be in the On position in order to make adjustments to the Aileron-to-Rudder mixing value.

4. With the current mix switch on, press the (+) or (-) key to increase or decrease the amount of rudder to be mixed with aileron. If you want to reverse the Rudder Mix direction, press the *Clear* key, bringing the mixing value to the factory default (0%), and increase the value using the opposite key (+) or (-) from the key originally selected.
5. To access the Elevator-to-Flap Mixing function, press the *Down* key.
6. To access the Landing Mode function, press the *Up* key.
7. To exit the Aileron-to-Rudder Mixing function, press the *Down* and *Channel* keys simultaneously.



CHAPTER 6: FUNCTIONS (FUNCTION MODE) • Airplane

Assigning the Mixing Activation Switch

The Aileron-to-Rudder Mixing program can be turned on and off using several different assignable

switch options. The switches that can be selected are shown to the right of the LCD display below.

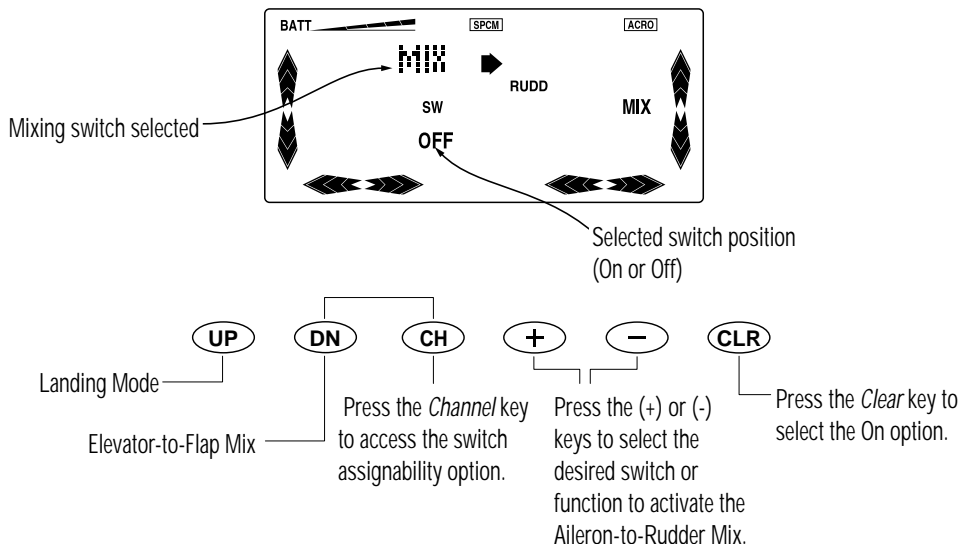

Assigning the Aileron-to-Rudder Mixing Switch Function

1. Place the transmitter power switch in the On position.
2. Access the Function mode. To do so, press the *Down* and *Channel* keys simultaneously.
3. Press either the Up or Down key until "AILE-RUDD" appears in the center portion of your LCD.
4. Press the *Channel* key to access the switch assignment function.
5. Press the (+) or (-) key to select the desired switch/function to activate the Aileron-to-Rudder Mixing function.
6. To access the Elevator-to-Flap Mixing function, press the *Down* key.
7. To access the Landing Mode function, press the *Up* key.
8. To exit the Aileron-to-Rudder Mixing function, press the *Down* and *Channel* keys simultaneously.

CHAPTER 6: FUNCTIONS (FUNCTION MODE) • Airplane

6.9 LANDING MODE FUNCTION

The Landing Mode function automatically couples the spoilers to the landing system. This inhibits the use of the AUX 2 lever, preventing activation of the spoilers at any other time than during use of the

landing system. Spoilers are connected to the AUX 2 channel on the receiver. The spoiler activation device will then be linked to the landing position of the Flap Mix switch.

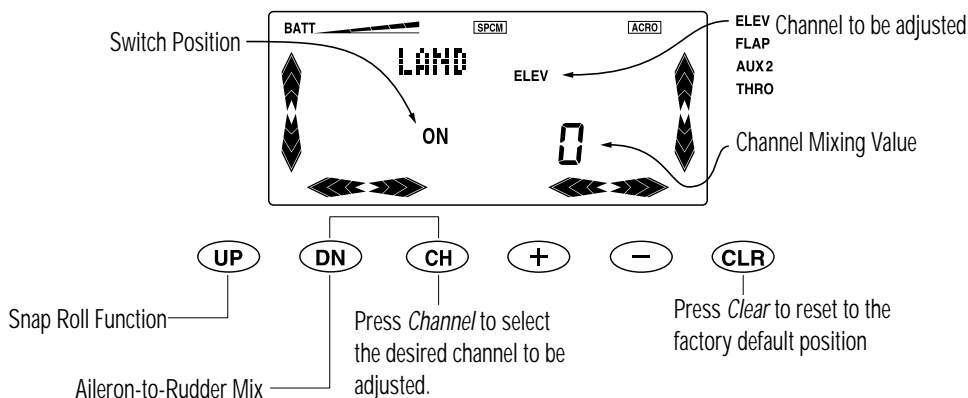

Accessing the Landing Mode Function

1. Place the transmitter switch in the On position.
2. Press the *Down* and *Channel* keys simultaneously to enter the Function mode.
3. Press either the *Up* or *Down* key until "LAND" appears in the center of the LCD.
4. Press the *Channel* key until "THRO" appears at the upper right portion of the LCD.
5. Press the *Channel* key to select the desired channels to be adjusted.
6. Use the (+) or (-) keys to set the desired landing mode surface positions.

Note: The Flap position switch must be placed in the LAND position for the values of the Landing Mode function to be altered/adjusted. If the display indicates "OFF," values cannot be altered.

To Inhibit the Aux 2 Lever

1. Press the *Channel* key until "INH" is displayed in the upper portion of the LCD.
2. Press the (+) or (-) keys to inhibit the Aux2 lever. The display will change from "INH" to "ACT," indicating that the Aux2 switch inhibit function has been activated. To check to see that the Aux2 lever has been de-activated, move the Aux2 lever while at the Aux2 switch selection screen. If the lever is deactivated, the display will not indicate changes when the switch is pressed.
3. To access the Aileron-to-Rudder Mixing function, press the *Down* key.
4. To access the Snap Roll function, press the *Up* key.
5. To exit the Landing Mode function, press the *Down* and *Channel* keys simultaneously.



CHAPTER 6: FUNCTIONS (FUNCTION MODE) • Airplane

Accessing the Automatic Landing Mode Function

1. Move the transmitter switch to the On position.
2. Press the *Down* and *Channel* keys simultaneously to enter the Function Mode.
3. Press either the *Up* or *Down* key until "LAND THRO" appears in the upper portion of the LCD, with (-) at the bottom right corner.
3. Set the Flight mode switch in the LAND position (Low).
4. Move the throttle stick to the desired position and press the (+) or (-) key. The (-) on the display will change to indicate the current throttle stick position value, and an "A" will appear at the upper right portion of the display. This is now the auto land point.
5. To access the Aileron-to-Rudder Mixing function, press the *Down* key.
6. To access the Snap Roll function, press the *Up* key.
7. To exit the Automatic Landing Mode function, press the *Up* and *Down* keys simultaneously.

Note: When this function is active, the letter "A" will appear at the upper right portion of the LCD.

Automatic Landing System

When the Automatic Landing Mode function is active, the throttle stick will activate the landing system setup on the preceding page. Any point of throttle stick travel can be set as the auto landing point. Once the throttle stick passes through this point, and the Flap Mix switch is in the land position, the landing system will be activated. Thus, the elevator, flaps and spoilers would be activated if

all were selected. If the Flap Mix switch is not in the Land function, the throttle operation will have no effect on the landing system.

Note: When the Automatic Landing function is active, the letter "A" will appear at the upper right portion of the LCD.

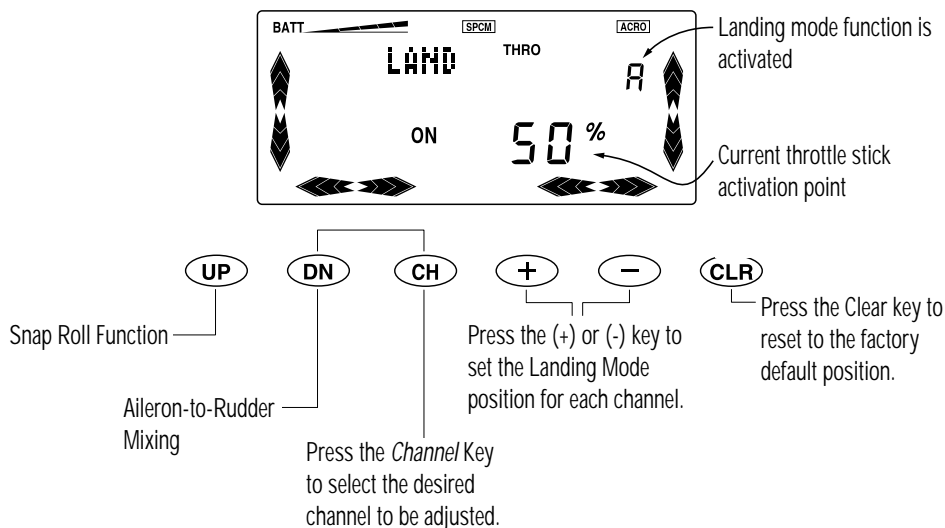

CHAPTER 6: FUNCTIONS (FUNCTION MODE) • Airplane

6.10

SNAP ROLL FUNCTION

The Snap Roll function allows for easy and consistent snap rolls at the touch of a switch. The X-378 offers four separate directions of snap rolls that you can select by using the keys located on the front of the transmitter.

Selectable snap rolls are as follows:

- R-DN Snap Roll Right and Down
- R-UP Snap Roll Right and Up
- L-DN Snap Roll Left and Down
- L-UP Snap Roll Left and Up

The Snap Roll switch affects the aileron, elevator and rudder only; all other functions work as normal. While the snap roll switch is activated, the related sticks will not operate until the switch is released. When this function is inhibited, the display will show "INH" and the snap roll system will not operate. Individual adjustment is available for each control surface in either direction. The adjustable range for each function is 0-125%; the factory default is 100%. When the Snap Roll function is active, the direction will be indicated with the appropriate arrows in the bottom left portion of the normal display screen.

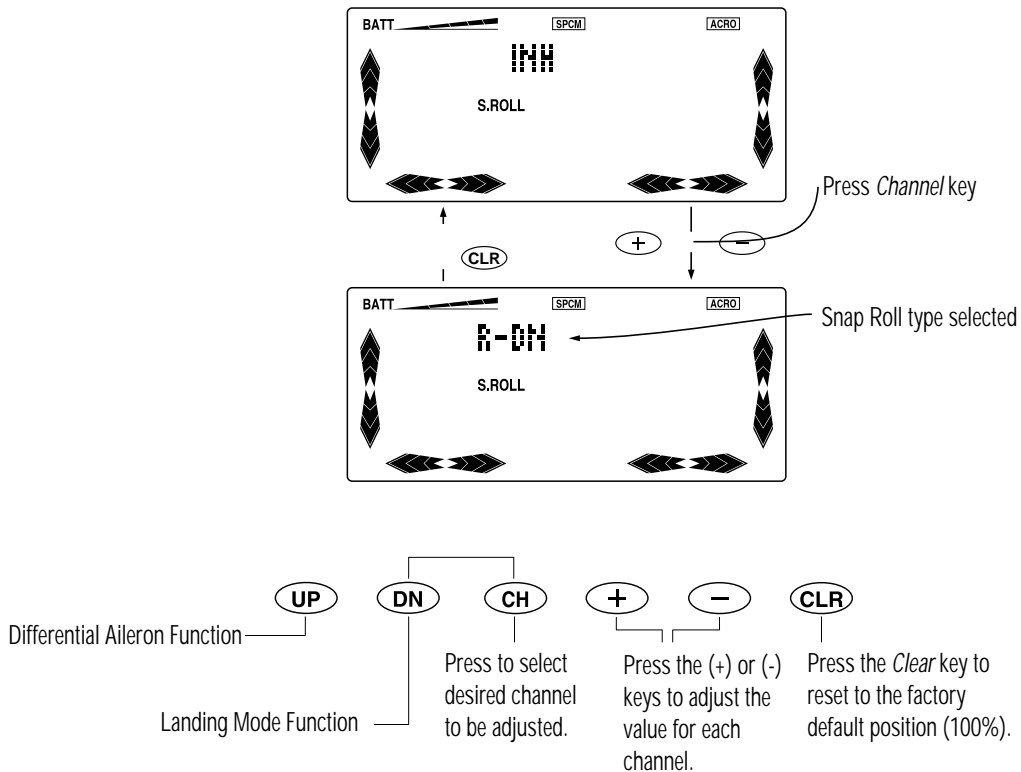

CHAPTER 6: FUNCTIONS (FUNCTION MODE) • Airplane

Accessing the Snap Roll Function

1. Move the transmitter switch to the On position.
2. Access the Function mode by pressing the Down and *Channel* keys simultaneously.
3. Press either the Up or Down key until "S.ROLL" appears in the center portion of the LCD.
4. Press the (+) or (-) key until the desired snap roll direction is displayed in the upper portion of the LCD directly above "S.ROLL."
5. Press the *Channel* key to display each of the three channels with their respective control values. Press the (+) or (-) key to increase or decrease the values for each control. The adjustable value is 0-125%.
6. Press the *Channel* key until the snap roll direction is displayed again. Press the (+) or (-) key to change the snap roll to the next direction. All four snap rolls, with travel values, can be set Up for each airplane and retained in memory.
7. Repeat Steps 5 and 6 again as needed.
8. To access the Automatic Landing Mode function, press the *Down* key.
9. To access the Aileron Differential function, press the *Up* key.
10. To exit the Snap Roll function, press the *Down* and *Channel* keys simultaneously.

AILE - Aileron
ELEV - Elevator
RUDD - Rudder

Snap Roll Direction Change

Once the snap rolls are established in the Function mode, they can be selected using the keys located on the front of the transmitter while in the normal display. The keys shown below will explain how to make these changes.

Note: When the Snap Roll function is active, the snap roll switch will not activate the stopwatch. It can be started and stopped using the (+) or (-) keys.

Caution: When the transmitter is being used as the master transmitter while training, the Snap Roll Function is inhibited.

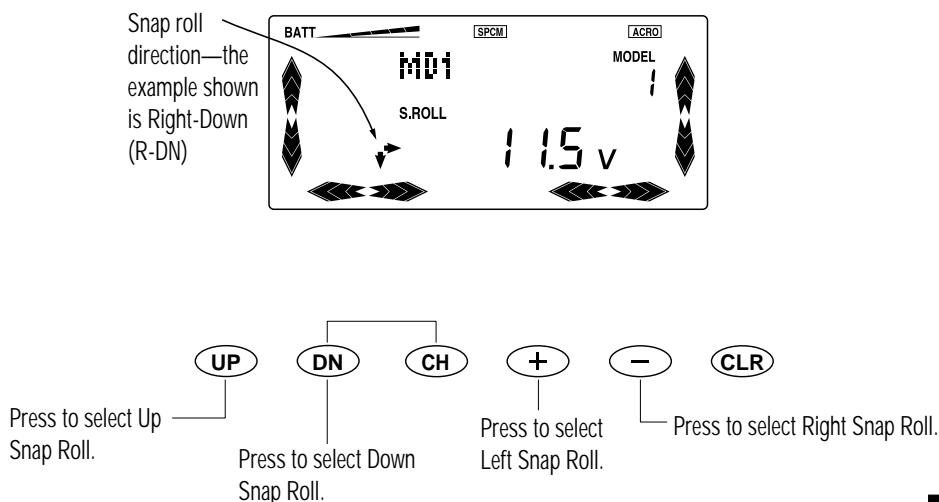

CHAPTER 6: FUNCTIONS (FUNCTION MODE) • Airplane

6.11

DIFFERENTIAL AILERON MIXING

The X-378 transmitter offers aileron differential for the flapperon and delta-wing mixing selections. Differential ailerons are used to tailor the flight control system to a particular aircraft. Because the downward travel of the aileron creates more drag than does the upward travel, it is necessary to reduce the amount of down travel for each aileron electronically. This drag may very well produce a yawing tendency in your aircraft. As yaw is undesirable in most, if not all, R/C aircraft, it is best

to correct for this common flight tendency. Aileron differential overcomes the yaw as it reduces the downward travel of the ailerons.

Note: In order to use the Differential function, flapperon or delta-wing mixing must be selected in the System mode, and two servos must be used to operate the ailerons, one each. Refer to the Wing Mixing section for more information.

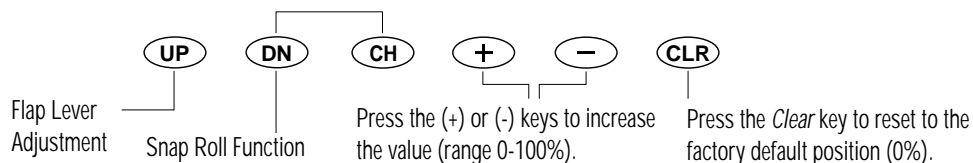
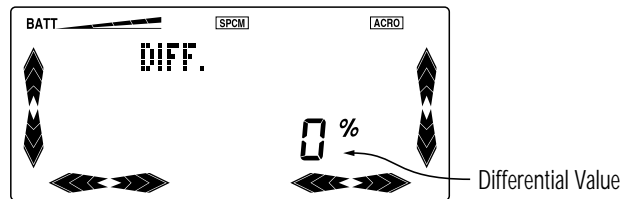

CHAPTER 6: FUNCTIONS (FUNCTION MODE) • Airplane

Accessing the Differential Aileron Mixing Function

1. Place the transmitter switch in the On position.
2. Press the *Down* and *Channel* keys simultaneously to enter the Function mode.
3. Press either the *Up* or *Down* key until "DIFF" appears in the upper left corner of the LCD. Press the (+) or (-) key until the desired amount of differential is established. The operating range for differential is 0% (NORM) to 100% (SPLIT). The following diagrams may ease the understanding of the differential aileron.

If left at 0%, the ailerons maintain equal travel for both sides. There will not be any differential whatsoever. If set at 50%, the aileron that is lowered travels 50%, or half, as far as the upward aileron. If adjusted to 100%, you achieve what is commonly referred to as a "split." This means that the only aileron that moves is the aileron that travels upward. The aileron that normally drops remains stationary.

4. To access the Snap Roll function, press the *Down* key.
5. To access the Flap Lever Adjustment, press the *Up* key.
6. To exit the Aileron Differential Mixing function, press the *Down* and *Channel* keys simultaneously.

MIXING FUNCTION



NORM: 0% Differential



DIFF: 50% Differential



SPLT: 100% Differential

CHAPTER 6: FUNCTIONS (FUNCTION MODE) • Airplane

6.12 FLAP LEVER ADJUSTMENT

The Flap Lever Adjustment function allows the output value of the Flap Channel (Aux1) lever (Front right of TX) to be adjusted to allow for fine or coarse movement of the flaps relative to the Lever.

There are 3 different options for this function, they are as follows:

TRIM

This function is used in conjunction with the Landing Mode function. When selected, the flaps position can be adjusted using the flap lever while in Landing Mode. This is not a commonly used function. The factory default position is 30%.

OFF

When this function is selected, the flap lever is deactivated. The flaps will now only function through

the Flap Mix switch when the Landing Mode is selected, and a value is given. This is the most commonly used function of the Flap Lever Adjustment function. The factory default position is 0%.

FULL

When this function is selected, the flaps will operate through the flap lever. This function is used only when the Landing Mode function is not selected. The factory default position is 100%.

Please note that if both the Landing Mode and the Full functions are selected, both functions will be operational. This is not a desirable option.

The value of the flap lever can be altered to any desired value using the (+) or (-) keys. This function makes fine-tuning of the flaps very easy.

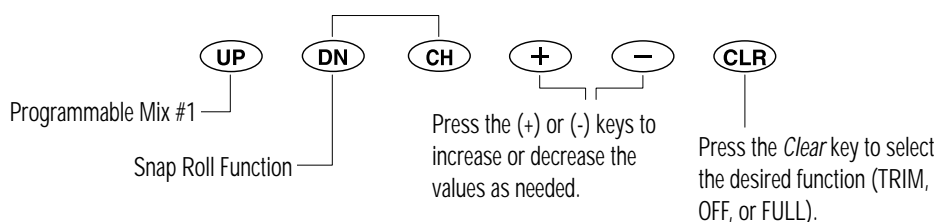
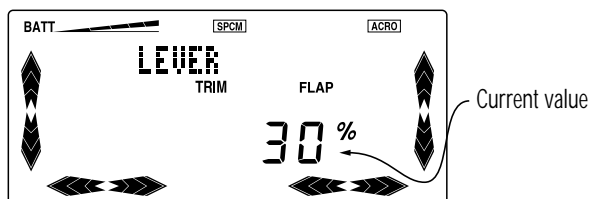

Accessing the Flap Lever Adjustment Function

1. Place the transmitter switch in the On position.
2. Press the *Down* and *Channel* keys simultaneously to enter the Function mode.
3. Press either the *Up* or *Down* key until "LEVER TRIM" appears in the center of the LCD.
4. Press the *Clear* key to select the desired function to be adjusted (TRIM, OFF, FULL).
5. Press the (+) or (-) key until the desired amount of flap travel is established.
6. To access the Snap Roll function, press the *Down* key.
7. To access the Programmable Mix #1 function, press the *Up* key.
8. To exit the Flap Lever Adjustment function, press the *Down* and *Channel* keys simultaneously.



CHAPTER 6: FUNCTIONS (FUNCTION MODE) • Airplane

6.13 PROGRAMMABLE MIXING 1-6

The X-378 offers six programmable mixes to be used for any number of different purposes. This function allows mixing any one channel to any other channel to make the aircraft easier to fly. This mix can remain on at all times or be switched on and off in flight using a number of different switches.

Mix numbers 1-4 are of the standard variety, in that the digital trim for the master channel only affect the master channel, and not the slave channel. Mix numbers 5 and 6 are of the "Trim Include" variety. These mixes are used any time the mix you are performing requires the slave channels trim position to be varied when the master channels digital trim position is varied. An example for this type of mix would be when dual elevator or dual aileron servos are used and connected to two separate channels of the system, rather than using a single channel with a Y-harness.

Each channel of this radio is identified by an abbreviated name. The chart below indicates the channel and its corresponding abbreviation. The channel name appearing first is known as the "master channel" or the channel to which you want to mix. The second number is known as the "slave channel" or the channel that is being mixed into the master channel. For example, "AILE-RUDD" would indicate aileron-to-rudder mixing. Each time the aileron stick is moved, the aileron will deflect, and the rudder will automatically move in the direction and to the value input.

Mixing is proportional, so small inputs of the master channel will produce small outputs of the slave channel. Each programmable mix has a mixing "offset." The purpose of the mixing offset is to re-define the neutral position of the slave channel.

- THRO: Throttle
- AILE: Aileron
- ELEV: Elevator
- RUDD: Rudder
- GEAR: Retract
Landing Gear
- FLAP: Flap (AUX 1)
- SPOI: Spoiler

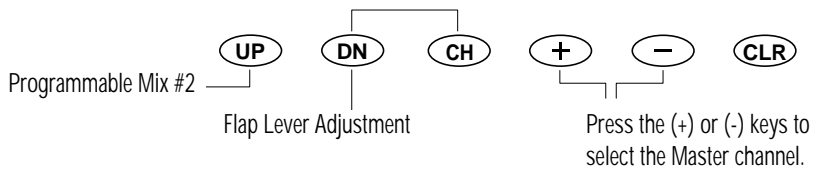
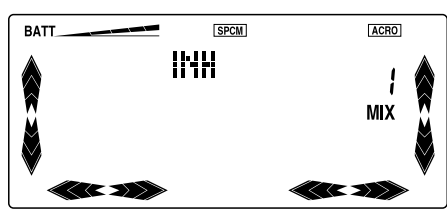

CHAPTER 6: FUNCTIONS (FUNCTION MODE) • Airplane

Accessing the Programmable Mixing Function

1. Place the transmitter switch in the On position.
2. Press the *Down* and *Channel* keys simultaneously to enter the Function mode.
3. Press either the *Up* or *Down* key until "MIX 1" appears in the upper right portion of the LCD.

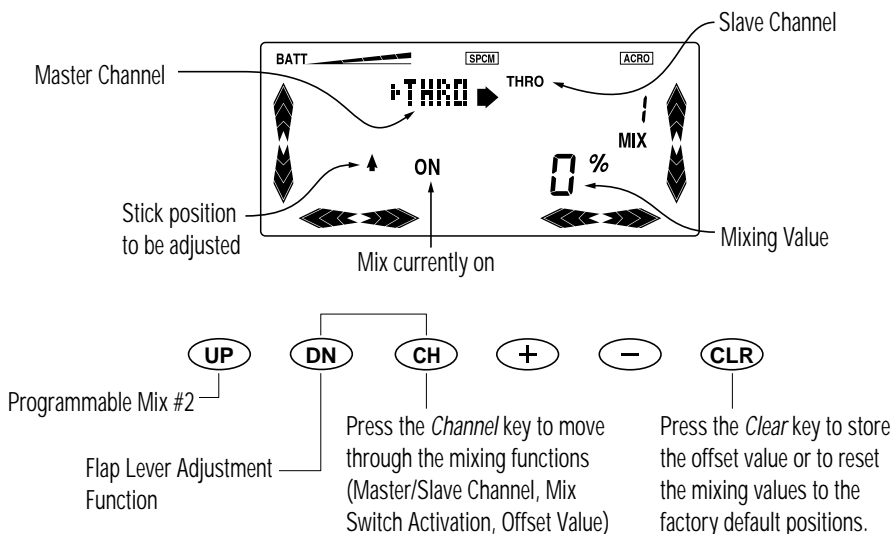

Selecting the Master and Slave Mixing Channels

4. Press the (+) key to activate the mix. Next, press the (+) or (-) keys again to select the master channel.
5. Press the *Channel* key to move the cursor to the slave channel position.
6. Press the (+) or (-) keys to select the slave channel.
7. Press the *Channel* key once. The display will continue to show the current mixing channels at the top of the LCD, but will now have a flashing arrow at the bottom left of the LCD to indicate the current stick position (master) to be adjusted.

Setting the Mixing Values

8. While holding the master stick in the direction you want to mix, press the (+) or (-) keys to increase or decrease the mixing value for the slave channel. The value at the lower right of the LCD will change to display the current mix value selected. Next, hold the master stick to the other side to adjust the mix for the other direction.

Note: The current mixing switch must be in the On position for the mixing values to be adjusted.

Setting the Mixing Switch Activation

9. Press the *Channel* key once again. The display will have "SW ON" indicated at the center portion of the

LCD with the word "ON" located in the upper right of the LCD. This indicates the current switch assignment to activate this mix. "ON" indicates that this mix is currently selected to always be active (ON).

Mixing Operation and Switches

Each mixing program can be turned on and off by a lever or switch. The levers and switches that can be selected for program mixing are tabulated at the right with their abbreviations appearing on the display and their corresponding positions.

The mix switch options for Mix #1, 2, and 5-6 are:

- ON: Always On
- MIX: Activated by the RUDD D/R/Mix switch
- LAND: Activated in the LAND position of the Flap Mix switch
- ELE>F: Activated in the ELEV position of the Flap Mix switch

The Mix switch options for Mix # 3 and 4 are:

- ON: Always On
- GEAR: Activated by the Gear Switch
- LAND: Activated in the LAND position of the Flap Mix switch
- ELE>F: Activated in the ELEV position of the Flap Mix switch

CHAPTER 6: FUNCTIONS (FUNCTION MODE) • Airplane

Accessing the Programmable Mixing Function continued

Setting the Mixing Channel Offset

1. Press the *Channel* key once again. The display will show the current mixing channels at the top of the 4 LCD, with the word "OFFSET" at the center of the LCD. The value to the lower right is the mixing Offset neutral point, currently 0.
2. Hold the master stick in the position you want to make the neutral point of the slave channel and push the *Clear* key. A new value with a (+) or (-) sign will appear. This is the new neutral point for the slave channel (Point that the mix is activated). To reset the value back to 0, move the master stick back to the center position, and press the *Clear* key to reset.

Note: The master channel trim must be centered for this to reset to 0 using the *Clear* key.

3. Press the *Down* and *Channel* keys simultaneously to exit the Programmable Mix function.

Note: With a little practice, programmable mixing will become easier compared with the first time you try it. The best part of a computer radio is that if you don't like something, you can change it. Mixing is only limited by your imagination.

Setting the Mixing Values

The X-378 transmitter has six multi-purpose programmable mixes available. For these mixing operations, first determine the mix type required (standard 1-4, or trim include 5-6), master and slave channels, offset and operating switch settings, if necessary, and then adjust the mixing value. For setting mixing value, move and hold the master channel control (up, down, left or right) and set the slave servo mix value by pressing either the (+) or (-) keys. To reverse direction of the slave mix, press the opposite of the (+) or (-) keys until the value of mix is set in the reverse direction.

Please also note that if the reference of the offset point is moved (see section below), the slave channel's direction will change from that position.

Setting the Mix Offset Position

Any position of the master channel can be used as a reference (starting) point for mixing. This is useful for channels that have no neutral position. With this function, you can use program mixing with respect to an arbitrary position of the lever/switch. To set the offset position, put the master channel at the desired position and press the *Clear* key. The position is stored in the memory and its offset value from the neutral position is indicated numerically on the display. Once this offset point has been set, the mixing value at the offset position is now set to zero.



CHAPTER 6: FUNCTIONS (FUNCTION MODE) • Airplane

Functions Related to Program Mixing

Selecting Flaps (Aux1) for the master channel:

When the slave channel is 2 (aileron), its mixing operation is affected by aileron differential settings. When the slave channel is 6 (flap), its mixing operation is affected by flap-to-aileron mix settings. When dual flaps are selected, and the slave channel is 7 (AUX 2), its mixing operation is affected by the aileron differential settings.

Trim Include Mixes 5 and 6

Programmable Mixes 5 and 6 offer mixing with the Trim Include function. The Trim Include function is automatically activated when mixes 5 and 6 are used.

Mixes 5 and 6 with Trim Include

Whenever the master channel is aileron, elevator, rudder or throttle, you have the option of allowing the master channel's trim lever to mix into the slave channel. The Mixing with Trim function is always activated in Mixes 5 and 6. You can observe the operation by watching the slave channel while moving the master channel's trim lever.

Note: If you have not yet entered values for the mixing percentages, the slave channel will remain stationary. Also, if the mixing percentages are minute, the movement of the slave channel from the trim lever is also minute.

Include Mixing

The Include Mixing function allows other programmed mixing values for the master channel. As stated previously, the Include Mixing function is always activated in Mixes E and F.

For example, Mix 3: AILE - THRO
 Mix 6: THRO - RUDD

Mix 6's operating value also now includes the operating value from Mix 3's master channel (Aileron). By moving the aileron control stick, Mix 3 has the ailerons mixing into the throttle, and now also the rudder from Mix 6. At the same time, Mix 6 is mixing the throttle into the rudder only. Since the Include Mixing is always active, you are also mixing your ailerons into the rudder. This results in the aileron stick moving not only the aileron servo but also the throttle and rudder servos.

Include Mixing may sound complex, but it actually eliminates the need for a third mixing program to mix the aileron and rudder channels. Therefore, Include Mixing reduces the number of mixing programs needed when using multiple mixing functions.



CHAPTER 6: FUNCTIONS (FUNCTION MODE) • Airplane

6.14 FAIL SAFE/HOLD FUNCTION (PCM ONLY)

The Fail-Safe/Hold function is available only when you use the X-378 transmitter in either of the PCM modulations-S-PCM or Z-PCM. This function is designed to help minimize damage to your aircraft during a loss of signal to the receiver. The servos either assume the fail-safe presets or hold their last good signal position.

Note: In the PCM modulations, the Fail-Safe/Hold function cannot be totally disabled so that the servos will react to interference in the same way as they do in a PPM (FM) system. This is only possible with

the use of a PPM receiver and the transmitter in the PPM modulation. Since the actual screen appearance varies depending on the modulation of your radio, refer to the appropriate modulation section that follows.

As noted earlier, if you are in the PPM modulation, the Fail-Safe/Hold function is not applicable. Therefore, the Fail-Safe/Hold function will not appear on your LCD screen menu while in the PPM mode. Refer to the Modulation Selection section for more information pertaining to the broadcast signal of your X-378 transmitter.

Accessing the Fail-Safe/Hold Function in Z-PCM Modulation

Hold (Z-PCM)

The Hold function is automatically activated when the radio is turned on and is in the Z-PCM modulation. This function stops (or holds) the servos in the positions they were in just prior to the

interference. Therefore, your aircraft maintains the position held immediately before the interference was experienced. When a clear signal is restored, the Hold function releases, and control of the airplane returns to you.

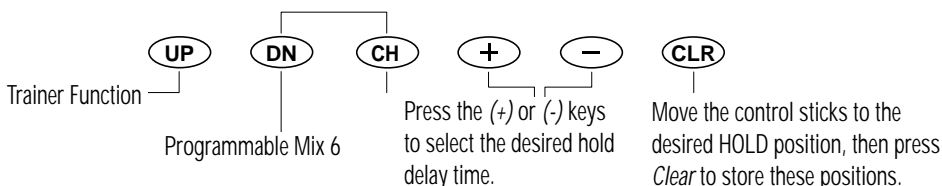
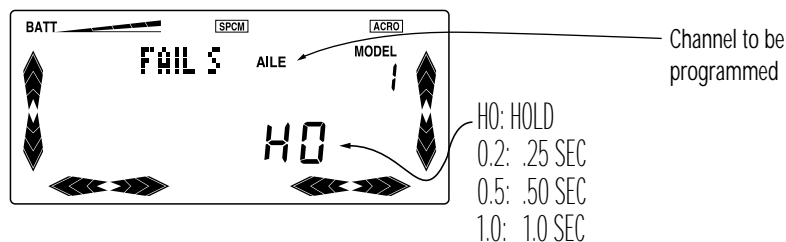

CHAPTER 6: FUNCTIONS (FUNCTION MODE) • Airplane

Accessing the PCM Hold Function (Z-PCM)

1. Place the transmitter power switch in the On position.
2. Press the *Down* and *Channel* keys simultaneously to access the Function mode.
3. Press either the Up or Down key until the "FAIL S" (Fail-Safe) appears in the upper left portion of the LCD.

Note: If "Fail-Safe" does not appear on your LCD, it is because you are transmitting in PPM. Fail-safe is not applicable in the PPM mode. Refer to the Modulation Mode Selection section for more information. You should never attempt to adjust the Fail-Safe function when the aircraft is running.

When the Fail-Safe function is activated (i.e., when the signal is interrupted), the transmitter automatically moves each servo to a preset position. The position that each servo assumes is determined by you, as is the time length of interference that must occur before servo movement.

After the interference has ceased, control of the aircraft returns immediately to you. There are three time delays to choose from: 0.25 second, 0.5 second and 1.0 second. These time delays are the amount of time it takes, starting the moment the interference occurs, until the servos assume their preset positions.

Setting the Fail Safe/Hold Memory in Z-PCM Modulation

1. After accessing the Fail-Safe function, adjust the fail-safe presets.
2. Select among the three time delays (.25, .50 or 1.0 second) by pressing the (+) or (-) key until the appropriate delay appears on the screen.
3. Next, hold the transmitter sticks in the positions that you want the servos to assume during signal loss conditions. You can determine fail-safe preset positions for the other channels by placing the other channel switches in the positions that you want them to assume during interference.
4. With the sticks and switches in the desired fail-safe positions, touch the *Clear* key. This will enter these locations as the fail-safe memory settings. A single high-pitched beep will be heard when the *Clear* key is pressed indicating that the positions have been memorized.
5. To confirm that the input of data was successful, switch the transmitter off. The controls will move to the input locations. If not, repeat Step 4 again.

Note: These preset positions remain stored in the transmitter's memory until both the transmitter battery pack and the lithium back-up battery have been removed (or until data reset has been performed). Therefore, you do not have to reset the Fail-Safe each time you fly. Should you want to re-adjust the Fail-safe presets, access the Fail-Safe function and adjust the presets as you have just done. The transmitter automatically recalls the settings for the last fail-safe adjustment.

7. To access the Programmable Mix 6 function, press the *Down* key.
8. To access the Trainer function, press the Up key.
9. To exit the Fail-Safe function, press the *Down* and *Channel* keys simultaneously.



CHAPTER 6: FUNCTIONS (FUNCTION MODE) • Airplane

Accessing the Fail-Safe/Hold in S-PCM Modulation

The S-PCM Hold function is automatically activated when the radio is turned on and is in the S-PCM modulation. This function stops (or holds) the servos in the positions they were in just prior to the interference. Therefore, your aircraft maintains the position held immediately before the interference was experienced. When a clear signal is restored, the Hold function releases, and control of the aircraft returns to you.

1. Place the transmitter power switch in the On position.

2. While the power switch is in the On position, press the *Down* and *Channel* keys simultaneously to access the Function mode.

3. Press either the *Up* or *Down* key until the "FAIL-S" (Fail-Safe) appears in the upper left portion of the LCD.

Note: If "Fail-Safe" does not appear on your LCD, it is because you are transmitting in PPM. fail-safe is not applicable in the PPM mode. Refer to the Modulation Mode Selection section for more information.

Fail-Safe/Hold Combination in S-PCM Modulation

The X-378 allows you to combine the Hold and Fail-Safe presets for all seven channels on the receiver. You can select Fail-Safe or Hold independently for all channels on your aircraft. In other words, some channels will hold their last clear signal position (HOLD), while others assume the preset position (Fail-Safe). Once the Fail-Safe has been activated by signal interruption (interference), the transmitter automatically moves the servos to a preset position.

The predetermined servo positions are set by you. In the S-PCM Fail-Safe, the time delay (the amount of time it takes, starting the moment the interference occurs, until the servos assume the preset positions) is fixed at .25 seconds. After the interference has ceased, normal operation of the aircraft returns to you immediately.



CHAPTER 6: FUNCTIONS (FUNCTION MODE) • Airplane

Setting the Fail-Safe/Hold Combination in S-PCM Moduation

1. Select all of the channels for which you want to enter a Fail-Safe preset. To do so, use the *Channel* key until the appropriate channel name appears in the upper right portion of the LCD. We will use the Aileron (AILE) for our example. The display will appear as shown above.
2. Press either the (+) or (-) key. This will change the display from Hold (HO) to the Fail-Safe (F.S.) preset display.
3. Repeat Steps 1 and 2 for all channels desired to be set to the Fail-Safe (F.S.) position.
4. Hold all of the appropriate transmitter control sticks and switches in the desired positions and press the *Clear* key. This will enter the location as the fail-safe memory setting for all channels selected to F.S. When the *Clear* key is pressed, a single high pitch beep will be heard indicating that the Fail-Safe positions have been stored. Continuing our example, hold the aileron stick to the right and press the *Clear* key.
6. To confirm that the input of data was successful to the applicable channels, switch the transmitter off.

All channels selected to Fail-Safe (F.S.) should to their selected positions.

Note: These preset positions remain stored in the transmitter's memory until both the transmitter battery pack and the lithium back-up battery have been removed (or until the Data-Reset function has been utilized). Therefore, you do not have to reset the Fail-Safe each time you fly. Should you want to re-adjust the Fail-Safe preset position, access the Fail-Safe function once again and adjust the presets as you have just done. The transmitter automatically recalls the settings for the latest fail-safe adjustment.

8. To access the Programmable Mix 6 function, press the *Down* key.
9. To access the Trainer function, press the *Up* key.
10. To exit the Fail-Safe/Hold function, press the *Up* and *Down* keys simultaneously.

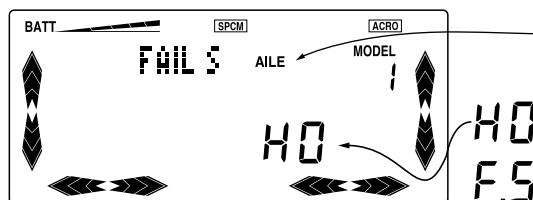

Indicates Fail-Safe channel to be programmed

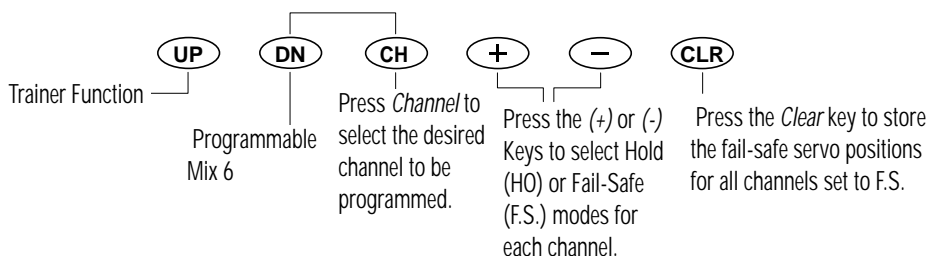

CHAPTER 6: FUNCTIONS (FUNCTION MODE) • Airplane

6.15 Trainer System

The X-378 transmitter employs two separate types of trainer systems:

1) Normal Trainer System

All functions are controlled by either the master transmitter (MAST) or the slave transmitter (SLAVE).

2) Programmable Function Trainer

Individual Channel Functions may be assigned to the slave one at a time. Since the control functions can be transferred one by one, students can concentrate on only one function at a time until they are competent to fly solo with all controls.

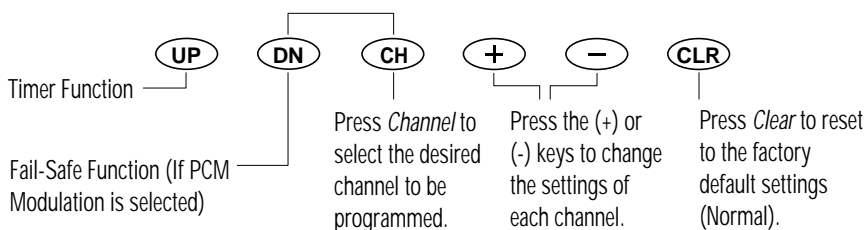
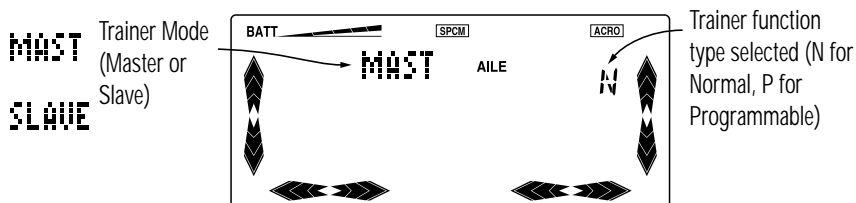

CHAPTER 6: FUNCTIONS (FUNCTION MODE) • Airplane

Accessing the Programmable Trainer Function

1. Move the transmitter switch to the On position.
2. Press the *Down* and *Channel* keys simultaneously to enter the Function mode.
3. Press the *Up* or *Down* keys until "MAST" appears on the center portion of the LCD.
4. Press the *Channel* key to select the channel to be adjusted. The channel name will be displayed just to the right of "MAST."
5. Once the channel appears that you want to make a slave, press the (+) or (-) key. This will change the display from "MAST" to "SLAVE." The "N" at the upper right portion of the LCD will also change to "P". If you want to make more slave channels, press the *Channel* key until the next desired channel is shown and press the (+) or (-) key to change the settings.

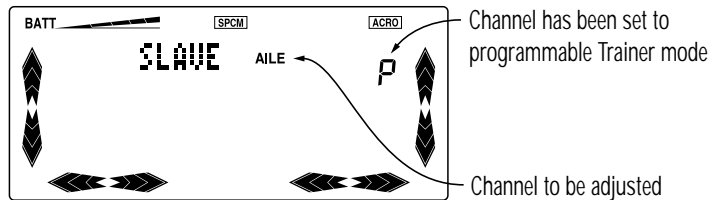

6. To change the Programmable Trainer Function back to the Normal Trainer System, press the *Clear* key.
7. To access the Fail-Safe function, press the *Down* key.
8. To access the Timer function, press the *Up* key.
9. To exit the Trainer function, press the *Down* and *Channel* keys simultaneously.



CHAPTER 6: FUNCTIONS (FUNCTION MODE) • Airplane

Basic Connections and Conditions for Training

1. The slave transmitter must be PPM (Pulse Position Modulation) and must be equipped with a DSC (Direct Servo Control) or trainer jack. If the slave transmitter is PPM/PCM selectable, select PPM. The master transmitter can be PCM or PPM.

2. Plug the trainer cord (optional part #JRPA130) into each transmitter's DSC/Trainer jack.

Note: Each transmitter will appear to be on, but neither is actually transmitting at this time.

3. Switch the master transmitter on. Do not switch on the slave transmitter; it is only necessary to have the master transmitter on.

Note: If the master transmitter is the X-378, the LCD will indicate "TRINR" (Trainer Master) and will list the channels that have been programmed when the power switch is on.

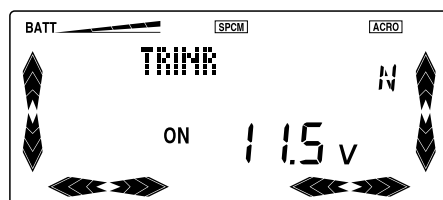

Example of normal display screen indicating trainer master with the normal (N) trainer function selected

4. Pull the trainer switch toward you to transfer control to the slave. Releasing the switch automatically reverts to the master transmitter.

5. Be sure the slave transmitter's servo reversing, dual rates, end-point adjustment and trims are identical to the master transmitter. This can be checked by pulling the trainer switch toward you. If the control surfaces move, adjust the slave transmitter until the trainer switch can be activated without a change of the control surface position.

Use of the Normal Trainer System

In this mode, all functions are switched from the master to the slave using the trainer switch. This is the Normal mode—no function setup is necessary to activate this system.

Use of the Programmable Trainer Function

In this mode, the master may assign functions to the student one at a time to make learning to fly easier. For example, the master may assign the slave aileron and elevator. Then, when the trainer switch is activated (pulled forward), the slave has control of aileron and elevator only while the master retains control of throttle and rudder.

Note: When all channels are set to master, the Trainer System becomes Normal.

CHAPTER 6: FUNCTIONS (FUNCTION MODE) • Airplane

6.16 TIMER FUNCTION

The X-378 offers two separate types of Timer functions: Countdown and Stopwatch.

The Countdown Timer time is input in 10-second intervals up to 35 minutes. The timer can be set for each individual model and retained in the memory for each model. Once the Timer function has been activated, it can be started and stopped from the Normal display screen using the Channel key. It can also be started and stopped using the snap roll/trainer button located at the front right portion of the transmitter. When the X-378 is being used as the master transmitter in the Training function the

trainer switch will not operate the timer start/stop function, and the timer function cannot be used.

Note: In the Countdown mode, the transmitter will beep three times at :30 seconds, two times at :20 seconds, and beep one time every second from :10 to 0. At zero there will be a continuous tone for 1 second and then the timer will begin counting up with a (+) indication to the left of the time value.

When used as the Stopwatch, the timer will count up to 44 minutes 59 seconds, at which time it will reset to zero and continue to count.

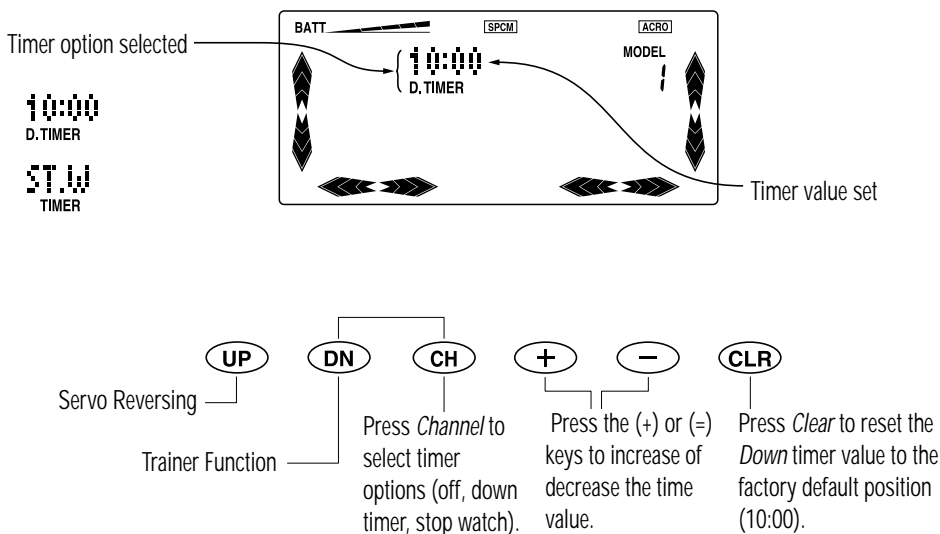

CHAPTER 6: FUNCTIONS (FUNCTION MODE) • Airplane

Accessing the Timer Functions

1. Place the transmitter switch in the On position.
2. Press the *Down* and *Channel* keys simultaneously to enter the Function mode.
3. Press either the Up or Down key until "TIMER" is displayed in the left portion of the LCD.
4. Press the *Channel* Key to select the desired timer option (Off, Down-Timer, Stopwatch)

Setting the Down-Timer value

Pressing the (+) key will change the display to :10 each time the (+) is pressed, and the value will increase in 10-second intervals up to 59:50 minutes. Pressing the *Clear* key will reset the Countdown Timer to the factory default 10:00 minute value.

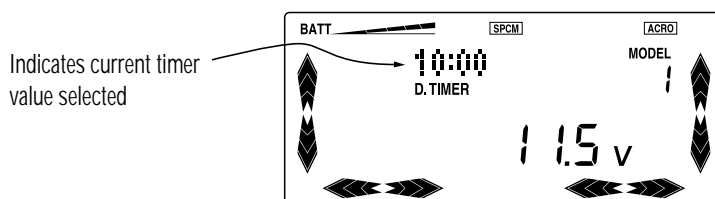

Indicates current timer value selected

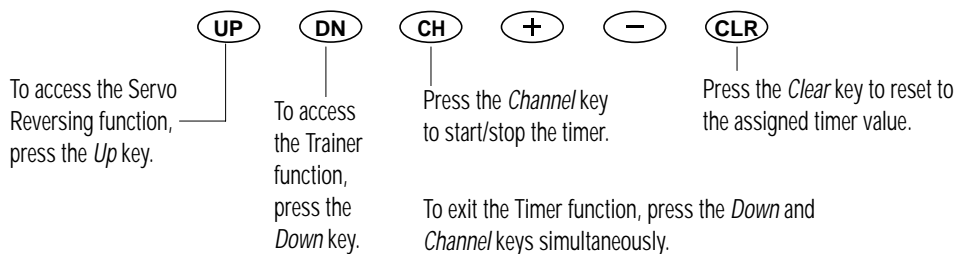

CHAPTER 7: PRACTICAL APPLICATIONS • Airplane

7.1 PROGRAMMABLE MIXING OPTIONS

1. "Super" Mix

If 100% of mixing value is not enough, you can use a second mix and mix more (or less, as the case may be) into the original mix. For example: You may want to mix the throttle channel to itself and remove the throttle for certain aerobatic maneuvers. If -100% is not enough, simply use an additional programmable mix (same channels, Offset, mixing switch assignment, etc.) and take the throttle out further.

2. Slow -Speed for Landing Approach

This mix slows down the engine to further ease the landing. This mix can also be used for an engine that idles too "hot" on the ground.

Connections and Mixing Operations

- Utilize one mix-to-mix throttle - throttle (THRO-THRO)
- Slightly adjust the mixing value percentage for the low throttle stick position, -5% for example.
- For the mixing operator switch, it is recommended that you use the land (LAND). Selecting the LAND allows you to employ landing operations simultaneously.
- To achieve the final mixing percentage, fly your aircraft and make adjustments as necessary.

3. Dual-Elevator Servo Operations

This is most applicable in quarter scale aircraft where one servo is not enough for the elevator controls.

Note: By using the Programmable Mix 5 or 6 Functions, a Y-harness is not necessary. This mix also corrects for the common problems of asymmetrical elevator control.

Connections and Mixing Operations

- Connect the elevator servos to the elevator (ELEV) and Auxiliary 2 (AUX 2) channels respectively.
- Use one of your program mixes (5 or 6 only), and mix elevator to AUX 2.

Note: Only mixes 5 and 6 offer the Trim Include Mixing function and it is necessary that the Digital trims also affect the slave channel (AUX 2) for this type of mixing.

With this special mix, your elevator servos function exactly the same as if only one elevator servo were used. Fine adjustments for servo direction and neutral points should be made using Servo Reversing and Sub-Trim functions.

Note: Each servo's adjustments are to be made individually.

For Travel Adjustment values, use the Travel-Adjust function.



CHAPTER 8: PRACTICAL APPLICATIONS • Airplane

X-378 DATA SHEET ACRO

MODEL NO. _____

MODEL NAME _____

MODULATION SPCM • PPM • ZPCM

	THRO	AILE	ELEV	RUDD	GEAR	FLAP	AUX2
REVERSE SW	NORM • REV	NORM • REV	NORM • REV	NORM • REV	NORM • REV	NORM • REV	NORM • REV
SUB TRIM							
TRAVEL ADJUST	H %	L %	D %	L %	+ %	U %	+ %
	L %	R %	U %	R %	- %	D %	- %
FAIL SAFE (SPCM)							

		AILE	ELEV	RUDD	
DUAL-RATE • EXP	0	D/R	%	%	%
		EXP	%	%	%
	1	D/R	%	%	%
		EXP	%	%	%
Snap Roll	INH • ACT	R-D	%	%	%
		R-U	%	%	%
		L-D	%	%	%
		L-U	%	%	%
A.D.T.					

AUTO RUDD D/R	OFF - ON
---------------	----------

ELEV→FLAP MIX	DOWN	%
	UP	%

AILE→RUDD MIX	RATE	%
	SW	

Landing	ELEV	
	FLAP	
	AUX2	INH • ACT
	AUTO	INH • ACT
	THRO	%

DIFFEREN	%
----------	---

		CHANNEL	SW	+POS	-POS	OFFSET
PROGRAM MIX	MIX1	→		%	%	
	MIX2	→		%	%	
	MIX3	→		%	%	
	MIX4	→		%	%	
	MIX5	→		%	%	
	MIX6	→		%	%	

FLAP LEVER TRAVEL	FLAP TRIM OFF FLAP FULL	%
----------------------	-------------------------------	---

Wing Type	NORM • FLPER DELTA
-----------	-----------------------------

INPUT SEL (Spoiler)	LEVR6 - MIX SW
---------------------	----------------



SECTION III • CHAPTER 1: SOFTWARE FUNCTIONS • Helicopter

1.1 CONTROL IDENTIFICATION AND LOCATION

Helicopter Version Transmitter

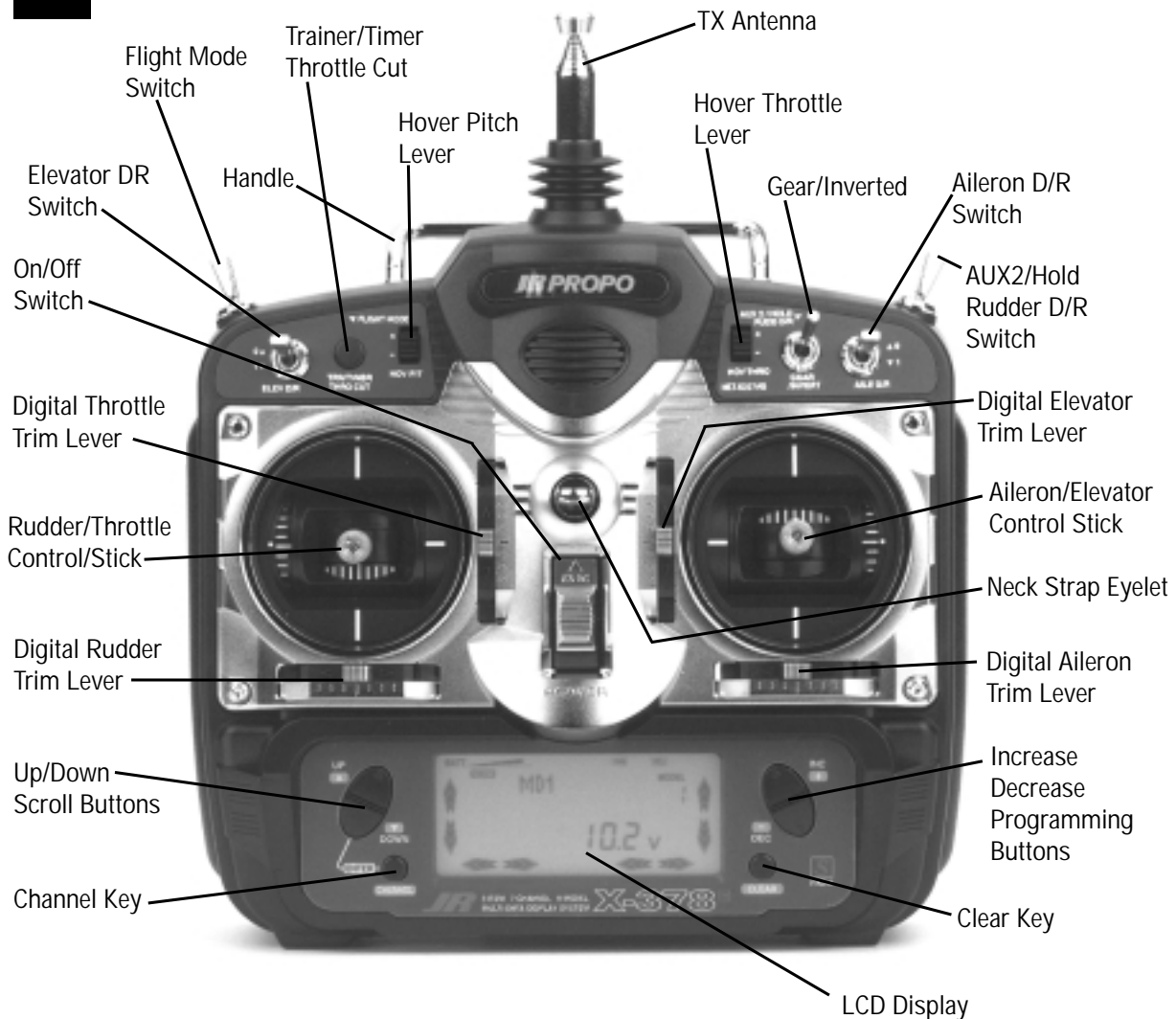

1.2 RECEIVER CHANNEL ASSIGNMENT

- | | | |
|----|-------|--|
| 1. | THRO | Throttle Channel |
| 2. | AILE | Aileron Channel |
| 3. | ELEV | Elevator Channel |
| 4. | RUDD | Rudder Channel |
| 5. | GEAR | Gear Channel |
| 6. | AUX 1 | Auxiliary 1 Channel (Pitch) |
| 7. | AUX 2 | Auxiliary 2 Channel (Gyro Sensitivity) |



CHAPTER 1: SOFTWARE FUNCTIONS • Helicopter

Helicopter Version Transmitter Airplane Mode

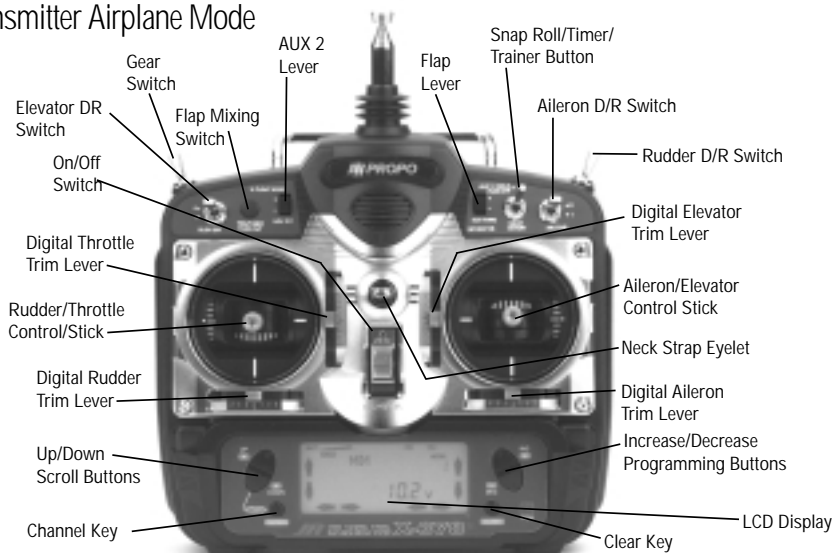

CHANNEL ASSIGNMENT

1.	THRO	Throttle Channel	5.	GEAR	Gear Channel
2.	AILE	Aileron Channel	6.	AUX 1	Auxiliary 1 Channel (Flap)
3.	ELEV	Elevator Channel	7.	AUX 2	Auxiliary 2 Channel (Spoiler)
4.	RUDD	Rudder Channel			

Helicopter Version Transmitter—Glider Mode

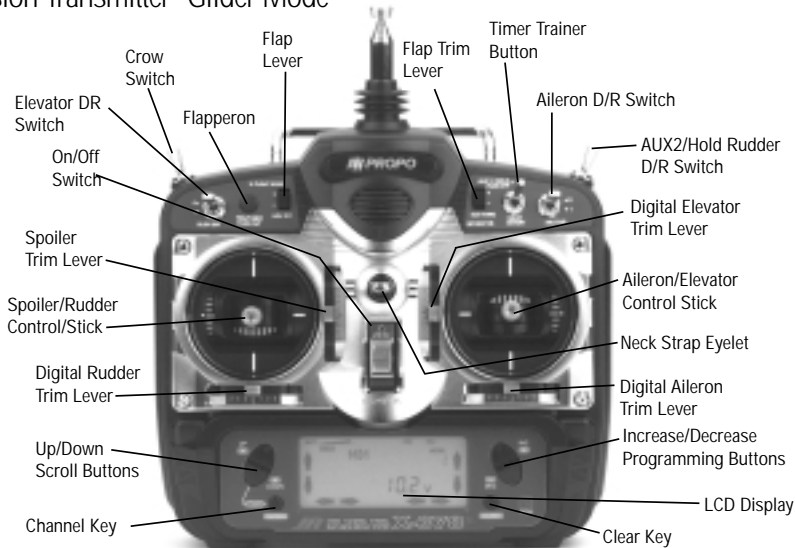

CHANNEL ASSIGNMENT

1.	THRO	Throttle Channel	5.	GEAR	Gear Channel
2.	AILE	Aileron Channel			(Left Aileron Channel—AIL 2)
3.	ELEV	Elevator Channel	6.	AUX 1	Auxiliary 1 Channel (Left Flap Channel for Dual Flaps)
4.	RUDD	Rudder Channel	7.	AUX 2	Auxiliary 2 Channel (Right Flap Channel for Dual Flaps)

CHAPTER 1: SOFTWARE FUNCTIONS • Helicopter

1.3 TRANSMITTER REAR

Transmitter Crystal Replacement Notice

The Federal Communications Commission (FCC) requires that changes in transmitter frequency must be performed only by an authorized service technician (Horizon Service Center). Any transmitter frequency change made by non-certified technician may result in a violation of the FCC rules.

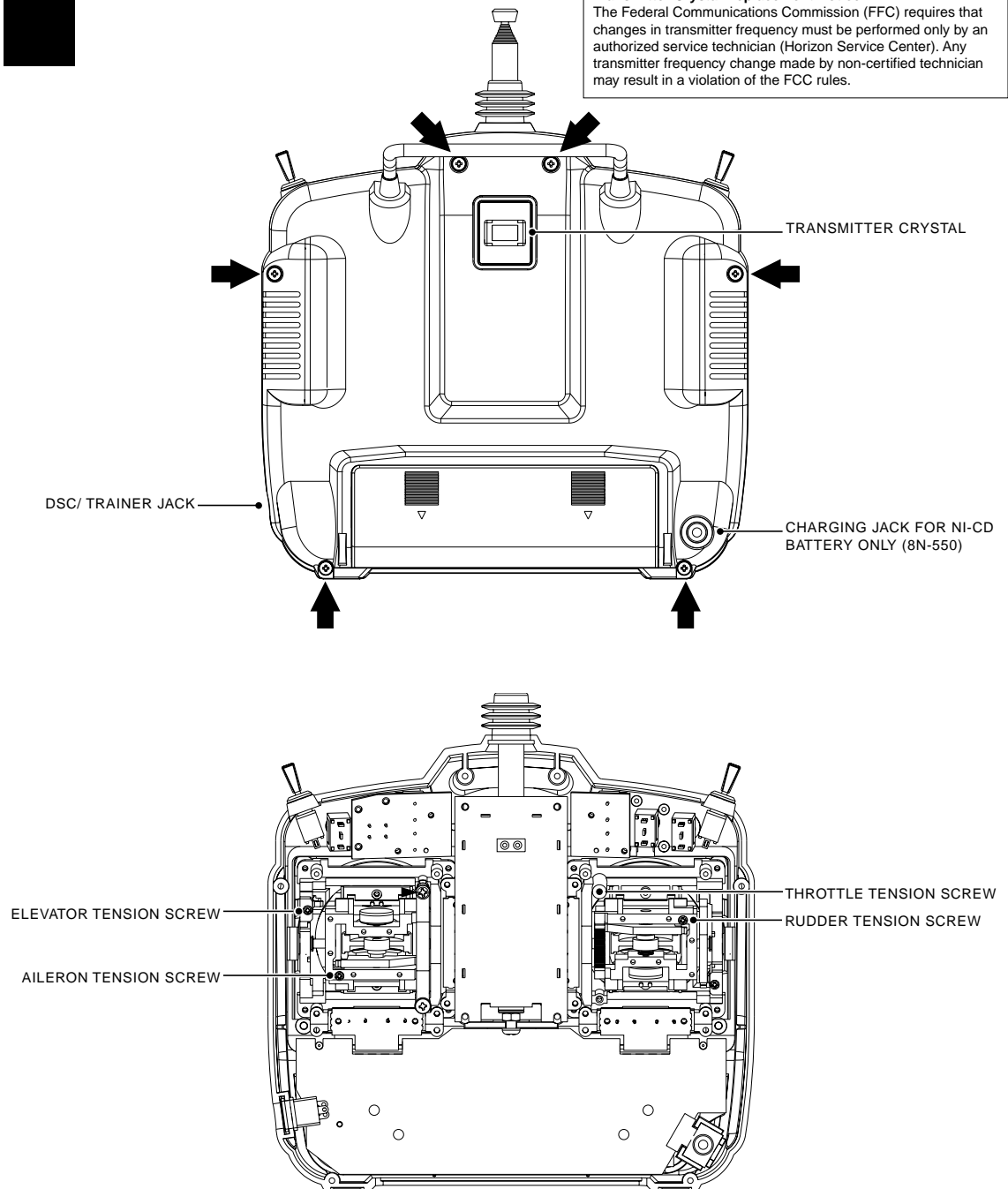

CHAPTER 1: SOFTWARE FUNCTIONS • Helicopter

1.4 CONTROL STICK LENGTH ADJUSTMENT

To adjust the stick length, use the 2mm Allen wrench (supplied with your X-378 transmitter) to unlock the set screw. Turn the wrench counterclockwise to loosen the screw. Then, turn the stick clockwise to shorten or counterclockwise to lengthen. After the control stick length has been adjusted to suit your flying style, tighten the 2mm set screw. If you desire longer sticks, JR offers a thicker stick (JRPA047) that is approximately one inch longer than the standard stick. This stick, crafted from bar stock aluminum, is available at your local JR dealer.

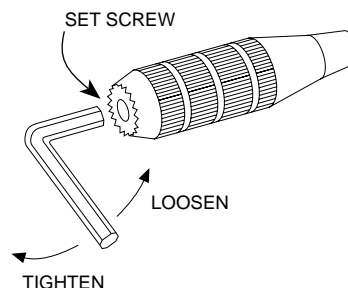

1.5 CONTROL STICK TENSION ADJUSTMENT

Remove the Ni-Cd battery and six transmitter back screws as shown at previous page. Remove the transmitter back, being careful not to cause damage to any components.

Adjust each screw for desired tension (counterclockwise to loosen stick feel; clockwise to tighten stick feel). When adjusting the throttle ratchet tension, make sure that the adjusting screw does not touch the PC board after adjustment is complete.

1.6 DIRECT SERVO CONTROL (DSC)

For proper DSC hook-up and operation:

1. Leave the transmitter power switch in the Off position. The transmitter will not transmit any radio frequency (RF) in this position.
2. Plug the (supplied) DSC cord into the DSC port in the rear of the transmitter.
3. The encoder section of the transmitter will now be operational and the LCD display will be lit.
4. Plug the other end of the DSC Cord into the receiver charge receptacle. Turn the switch harness to the On position.

Note: When you install the charging jack, be sure to hook the charging jack receptacle securely into the switch harness charge cord.

Why you should use the DSC function:

1. The DSC enables you to check the control surfaces of your aircraft without drawing the fully operational 200mAh from your transmitter battery pack. Instead, you will only draw 70mAh when using the DSC function.

2. The DSC function allows you to make final adjustments to your airplane without transmitting any radio signals. Therefore, if another pilot is flying on your frequency, you can still adjust your aircraft and not interfere with the other pilot's aircraft.

Note: Under no circumstances should you attempt to fly your aircraft with the DSC cord plugged in! This function is for bench-checking your model only.

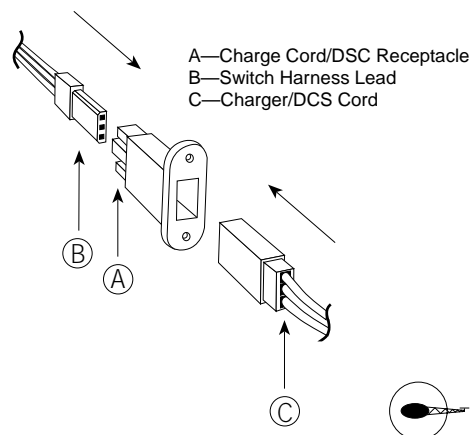

CHAPTER 1: CONNECTIONS • Helicopter

1.7 NECK STRAP ATTACHMENT

An eyelet is provided on the face of the XP-378 transmitter that allows you to connect a Neck Strap (JRPA023). This hook has been positioned so that your transmitter has the best possible balance when you use the neck strap.

Note: Double-check to ensure that the neck strap is securely fastened to the transmitter.

1.8 BASE LOADED ADJUSTMENT

An optional base-loaded antenna is available for use with the X-378 transmitter. It is considerably shorter than the standard antenna. However, the base loaded antenna cannot be collapsed for storage in the side of the transmitter. You must also use an

adaptor (JRPA156) to attach the antenna to your X-378. The Base Loaded Antenna (JRPA155) is made of a flexible coil and is covered with a soft plastic material. Your range will not be affected when using the base loaded antenna.

1.9 FREQUENCY NOTES/AIRCRAFT ONLY FREQUENCIES

The X-378 transmitter employs a plug-in crystal for transmitter that is glued in place at the time of shipment. Per FCC regulation, the transmitter crystal should only be changed by a certified technician. Changing of the transmitter crystal by a non authorized technician could result in a violation of FCC rules.

The X-378 can transmit in either Pulse Code Modulation (PCM) or Pulse Position Modulation (PPM, commonly referred to as FM).

Be certain to observe the following guidelines:

1. Do not operate your transmitter when another transmitter is using the same frequency, regardless of whether the second transmitter is PCM, PPM (FM) or AM. You can never operate two transmitters on the same frequency simultaneously without causing interference to both receivers and crashing both aircraft.

2. For operation of your X-378 with additional receivers, you should refer to the receiver compatibility chart. The chart is located in the Modulation Selection Section of this manual.

Aircraft-Only Frequencies

JR RF modules and receivers are available in 72MHz frequencies in the United States for use with model aircraft. Employing 72MHz frequencies does not require a special operator's license from the Federal Communications Commission (FCC).

* A chart for all available frequencies is located on page 185 of this manual.



CHAPTER 2: CONNECTIONS • Helicopter

2.1 INSTALLATION REQUIREMENTS

It is extremely important that your radio system be correctly installed in your model. Here are a few suggestions on the installation of your JR equipment:

1. Wrap the receiver in protective foam rubber that is no less than 3/8 inch thick. Secure the foam to the receiver with #64 rubber bands. This protects the receiver in the event of a crash or a very hard landing.
2. The servos should be mounted using rubber grommets and brass bushings to isolate them from vibration. Do not over-tighten the mounting screws; this will negate the vibration absorption effect of the rubber grommets. The diagram to the right will assist properly mounting your servo.



3. The servos must be able to move freely over their entire range of travel. Make sure that the control linkages do not bind or impede the movement of any of the servos.
4. Mount all switches away from the engine exhaust and away from any high vibration areas. Make sure the switch operates freely and is able to operate over its full travel.
5. Mount the receiver antenna firmly to the airplane to ensure that it will not become entangled in the propeller or control surfaces.

2.2 CONNECTIONS

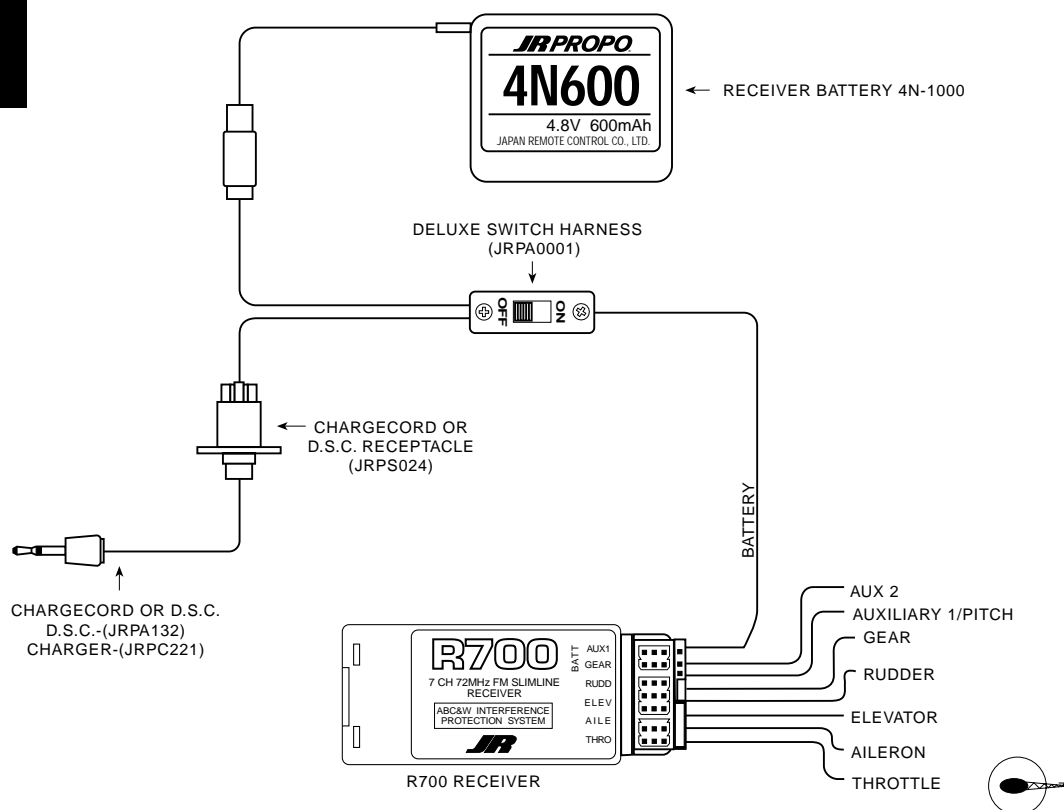

CHAPTER 3: INPUT MODE AND FUNCTION • Helicopter

3

KEY INPUT AND DISPLAY

The *Function Selection* keys are used to move up and down through the functions. The *Channel* key is used to advance the channel or function selected. The

Increase and *Decrease* keys are used to make changes in the selected functions.

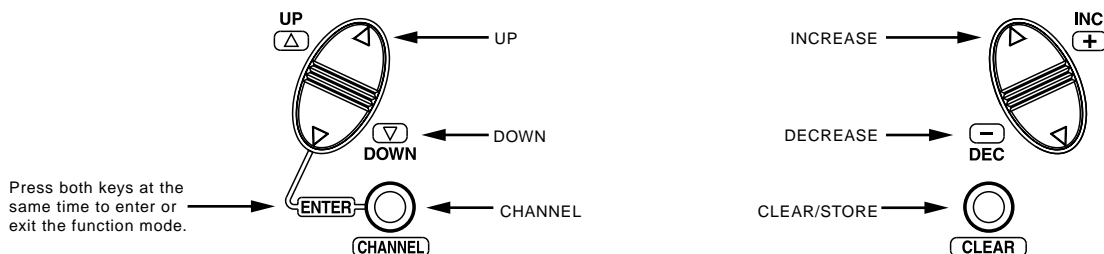

Hereafter, explanation of all functions in this manual will use the following designations to indicate pressing individual keys:



CHAPTER 4: ALARM AND ERROR DISPLAY • Helicopter

4.1

BATTERY ALARM AND DISPLAY

When the transmitter voltage drops below 9.0-volts DC, the display flashes "BATT" and an alarm sounds

seven times. If you are flying when this occurs, land immediately.

4.2

BACKUP ERROR DISPLAY

All preprogrammed data is protected by a five-year lithium battery that guards against main transmitter battery failure. Should the lithium battery fail, the display will indicate ERR1 regardless of the position of the On/Off switch. If this occurs, it will be necessary to replace the battery and reprogram all data. All transmitter programs will return to the factory default settings, and the data you have input will be lost. When it becomes necessary to replace the lithium back-up battery, contact JR Horizon Service Center. Due to the possibility of extensive

damage caused by improper removal or replacement, only JR Horizon Service Center is authorized to make this change.

ERR1



CHAPTER 5: SYSTEM MODE • Helicopter

5.1 NORMAL DISPLAY

When the power switch is in the On position, the display will read as follows:

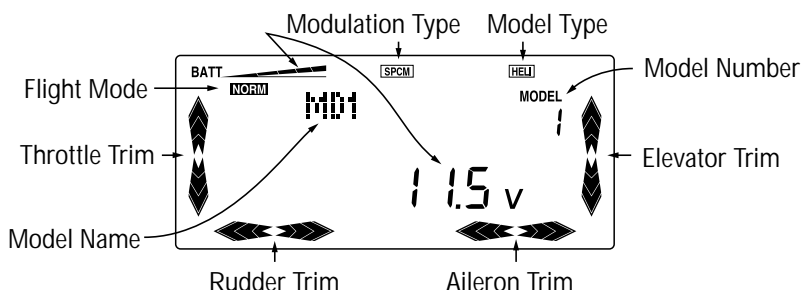

To enter the System mode, press simultaneously then turn on the power switch. To enter the Function model, turn on the power switch, then press simultaneously.

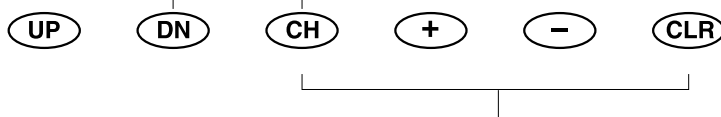

In the Timer mode, press the *Channel* key to start/stop the timer, and press the *Clear* key to reset the timer.

5.2 DIRECT ACCESS DIGITAL TRIMS

The X-378 is equipped with a Direct Access Digital Trim Value function. When at the normal display, if a digital trim lever is moved, the screen will automatically change to show the current trim value for the channel being adjusted. When the trim is returned to center, the screen will change back to the normal display screen after a few seconds.

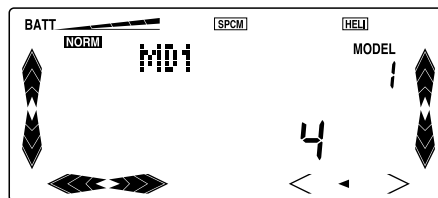

Displays the current trim value for the channel being adjusted

CHAPTER 5: SYSTEM MODE • Helicopter

5.3 SYSTEM MODE

To enter the System mode, press the *Up* and *Down* keys simultaneously, then turn the power switch to the on position. The display will show the last active program. Pressing either the *Up* or *Down* key then scrolls through the functions one by one, according to the system mode flowchart shown below. Once the appropriate function is displayed, changes can be made by pressing the (+) or (-) keys.

System Mode Flowchart

Information pertaining to each function is explained on the page listed next to the function name. Functions will appear in the same order they are shown on this chart.

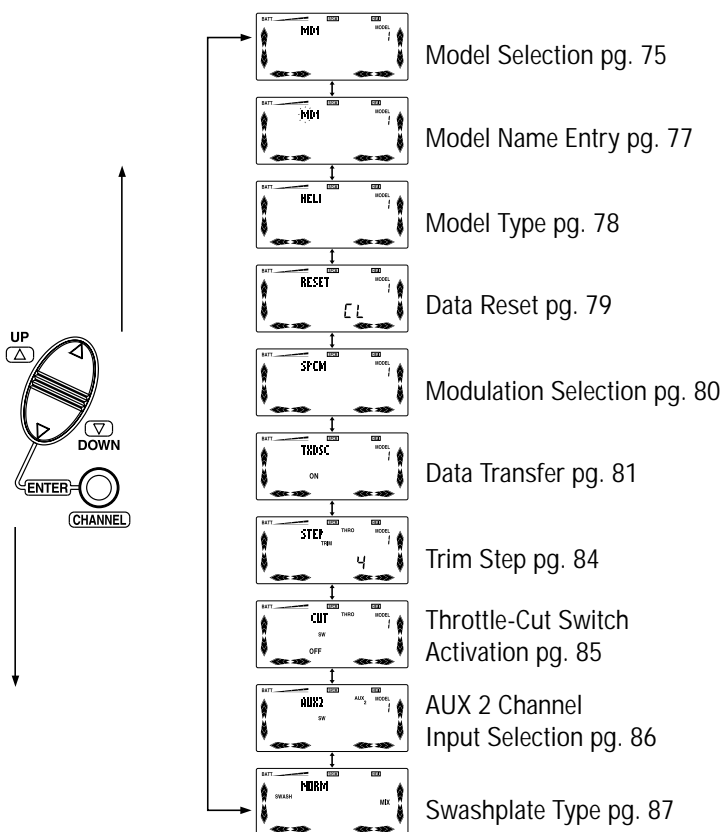

Accessing the System Mode

1. Press the *Up* and *Down* keys simultaneously.
2. Move the power switch to the On (upper) position.
3. Use either the *Up* or *Down* to scroll through the menu and access the applicable function.



CHAPTER 5: SYSTEM MODE • Helicopter

5.4 MODEL SELECTION/MODEL COPY SELECT

The X-378 system offers memory for eight completely separate models. Therefore, it is possible to have a mixture of helicopter, airplane and glider setups retained in memory. It is also recommended that the Model Name Entry function be used in conjunction

with each model setup. Another very useful function of the Model Selection function is the ability to set one aircraft up several different ways. This is helpful when multi-task performance is desired.

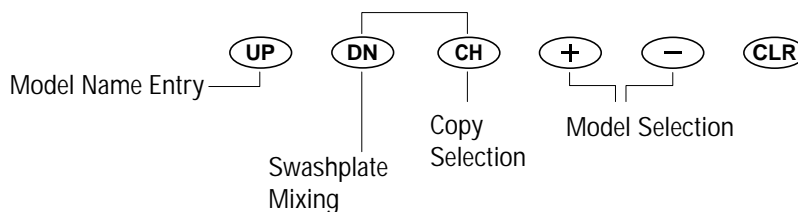
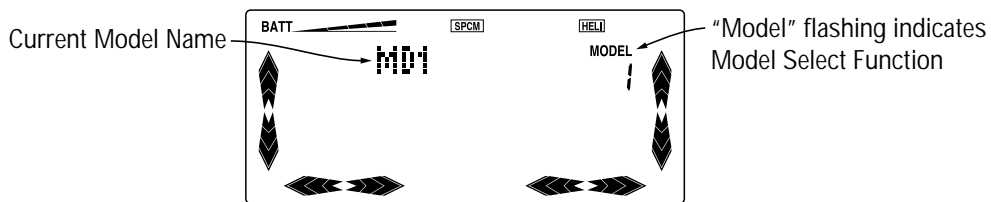

Accessing the Model Selection Function

1. While pressing the *Down* and *Channel* keys, switch the transmitter to the On position to enter the Model Setup mode.
2. Model should be flashing on the right top portion of the LCD. If not, press the *Up* or *Down* key until "Model" is displayed and flashing.
3. Pressing the (+) or (-) key will select among each of the eight models available. Notice that as each model is selected, its name appears in the left portion of the LCD.
4. To access the Copy Selection function, press the *Channel* key.
5. To access the Model Name Entry function, press the *Up* key.
6. Once the desired model is displayed on the left, pressing the *Up* and *Down* keys simultaneously will exit the Model Selection function and establish the model displayed as the new current model.

Note: When changing from one model type to another, it is not necessary to use the Type Selection function. This is done automatically by the computer.



CHAPTER 5: SYSTEM MODE • Helicopter

Model Copy Select

The Copy Selection function enables you to copy all of the settings of the current model to another model within the same transmitter. This is very

useful when setting up one aircraft several different ways or when trying an alternative setup of your current model.

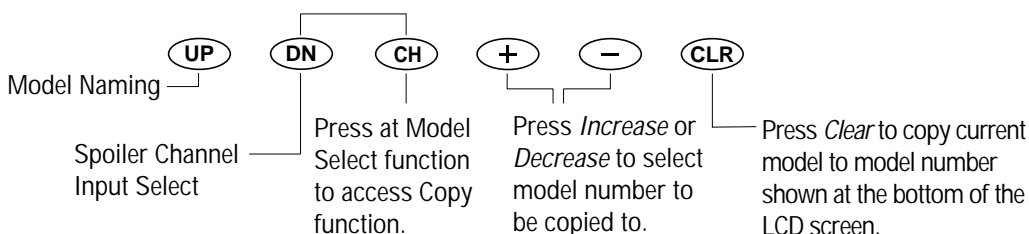
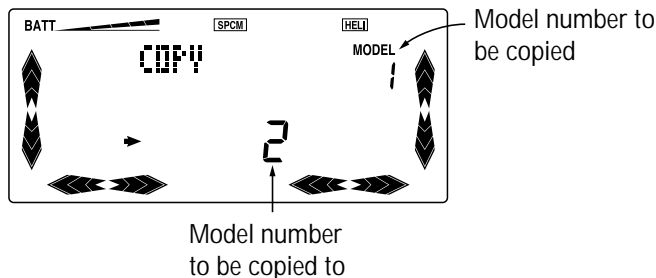

Accessing the Copy Selection Function

1. While pressing the *Down* and *Channel* keys, move the transmitter's power switch to the On position.
2. Press either the *Up* or *Down* key until "Model" appears flashing on the top right side of the LCD.
3. The number that appears below the flashing "Model" is the current model. This is important to note, as only the current model will be the copied or "from" model. Therefore, it is imperative to retrieve the proper current model prior to initiating the copy sequence. Press the *Increase* or *Decrease* keys to select the desired model to be copied.
4. Next, press the *Channel* key once. The word "Copy" will appear at the top left of the screen indicating that the Copy function has been selected.
5. The large number (1-8) at the bottom center of the LCD indicate the accepting model.
6. Press the *Increase* or *Decrease* keys to select the accepting model number.

no longer want to retain in your transmitter's memory. Once the copying process has been completed, the information of the accepting model is lost and the current model is input as the new data.

7. Once the desired accepting model is selected, press the *Clear* key to complete the Copy Selection function. The model number at the bottom of the screen will flash several times indicating that the model copy function was successful. The "from" (template) model's name and data will now replace that of the accepting model.
8. To access the Spoiler Channel Input Select function, press the *Down* key.
9. To access the Model Naming function, press the *Up* key.
10. To exit the Copy Selection function, press the *Down* and *Channel* keys simultaneously.



Note: Always make sure that the accepting model is either free of input or one which you

CHAPTER 5: SYSTEM MODE • Helicopter

5.5 MODEL NAME ENTRY

The X-378 allows a 3-digit name to be input for each of the eight models available. The current model will be displayed in the Normal display when the timer is

not active. You may also find this useful to identify different aircraft setups.

Flashing first digit indicates Model Naming function and current character to be changed

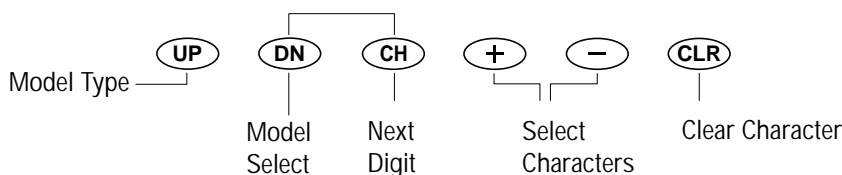
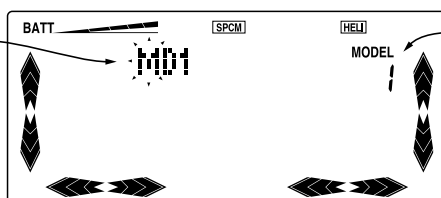

Accessing the Model Name Entry Function

1. While pressing the *Down* and *Channel* keys, switch the transmitter to the On (upper) position to enter the Model Setup mode.
2. Use the Model Selection function to select the model you want to name. (Please refer to the Model Selection section at this time.)
3. Press either the *Up* or *Down* key until the first digit of the model to be named is flashing on the left portion of the LCD.
4. The current name will be displayed in the left portion of the LCD. Pressing the (+) or (-) key will select the first alphanumeric character.

Note: The character being selected will flash.

5. Press the *Channel* key to advance the character selection to the next character.
6. Repeat this procedure until all three characters are selected.
7. To access the Model Selection function, press the *Down* key.
8. To access the Type Selection function, press the *Up* key.
9. To exit the Model Name Entry function, press the *Down* and *Channel* keys simultaneously.

CHAPTER 5: SYSTEM MODE • Helicopter

5.6 MODEL TYPE SELECTION

The X-378 is capable of performing as a helicopter, airplane or glider radio with full functions for each.

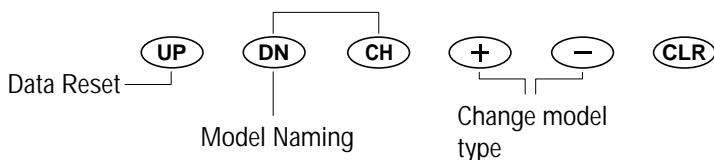
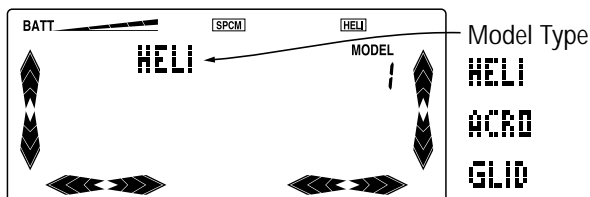

Accessing the Type Selection Function

1. While pressing the *Down* and *Channel* keys, switch the transmitter to the On position to enter the Model Setup mode.
2. Press either the *Up* or *Down* keys until "Acro," "Heli," or "Glid" is displayed in the left portion of the LCD.
3. Pressing either the (+) or (-) key will change the type of model.
4. To access the Model Name Entry function, press the *Down* key.
5. To access the Data Reset function, press the *Up* key.
6. To exit the Type Selection function, press the *Down* and *Channel* keys simultaneously.



CHAPTER 5: SYSTEM MODE • Helicopter

5.7 DATA RESET

The Data Reset function permits you to reset all the functions and settings for the current model to factory conditions. Resetting does not affect the data already programmed for other models. Be sure to

confirm that you need to reset the data of the currently indicated model in order to prevent accidental loss of your valuable data.

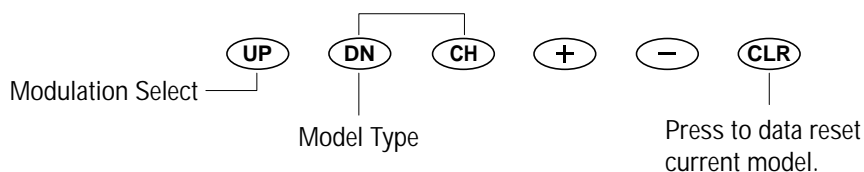
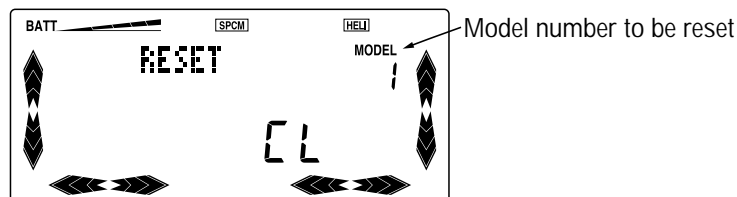

Accessing the Data Reset Function

1. While pressing the *Down* and *Channel* keys, switch the transmitter to the On position to enter the Model Setup mode.
2. Press the *Up* or *Down* key until "RESET" appears in the center of the LCD display. Check the number at the right side of the display to be sure the model selected is the model you want to reset.
3. To reset data, press the *Clear* key.
4. To access the Type Selection function, press the *Down* key.
5. To access the Modulation Selection function, press the *Up* key.
6. To exit the Data Reset function, press both the *Down* and *Channel* keys simultaneously.

CHAPTER 5: SYSTEM MODE • Helicopter

5.8 MODULATION SELECT

The Modulation Selection function enables your X-378 to transmit to a variety of JR receivers that are already, or may soon be, in existence. You can select from either of two types of PCM, Z-PCM or S-PCM, depending on the Central Processing Unit (CPU)

within your receiver or from linear PPM (Pulse Position Modulation [FM]).

Refer to the receiver compatibility chart below for the correct modulation.

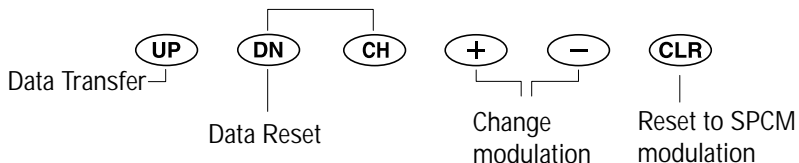
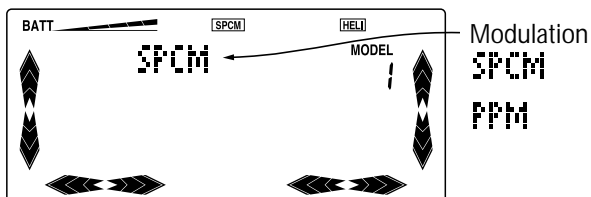

Accessing the Modulation Select Function

1. While pressing the *Down* and *Channel* keys, move the power switch to the On position to access the System mode.
2. Press either the *Up* or *Down* key until "SPCM," "ZPCM," or "PPM" appears at the top of the LCD.
3. To change among the modulation types, press either the (+) or (-) keys.

4. Pressing the *Clear* key will also reset the modulation selection to the factory preset S-PCM.
5. To access the Data Reset function, press the *Down* key.
6. To access the Data Transfer function, press the *Up* key.
7. To exit the Modulation Selection function, press the *Down* and *Channel* keys simultaneously.

Note: When the Data Reset function is used, the X-378 retains the current modulation selected for each model. This means that the modulation type does not change.

Note: In the normal display, the selected modulation type will appear in the middle of the LCD.

TX Modulation	Compatible Receivers	# of Channels & Brief Description	TX Modulation	Compatible Receivers	# of Channels & Brief Description
PPM	NER-226	6 (micro)	Z-PCM	NER-236	6 (micro)
PPM	NER-228	8	Z-PCM	NER-627XZ or 627 "G" series	7
PPM (FM)	NER-327x	7	Z-PCM	NER-J329P	9
PPM (FM)	NER-527x	7 (micro)	Z-PCM	NER-910XZ	10
PPM (FM)	NER-529x	9 (micro)	S-PCM	NER-955	10
PPM (FM)	NER-549	9	S-PCM	NER-D945	10
PPM	NER-600	6	S-PCM	NER-649S	9
PPM	NER-610M	6			
PPM	NER-700M	7			



CHAPTER 5: SYSTEM MODE • Helicopter

5.9 DATA TRANSFER FUNCTION

The X-378's Data Transfer function allows for a model from one X-378 transmitter to be sent to another X-378 transmitter by using a JR Trainer Cord (RPA130 sold separately).

Transmitting Transmitter: It will first be necessary to select the desired model (1-8) to be transferred to the receiving transmitter. Access the Model Select function and select the desired model number to be transferred (See section 5.4 for information)

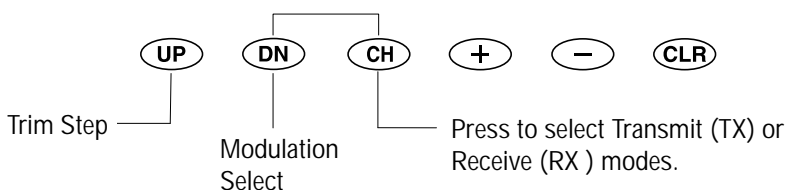
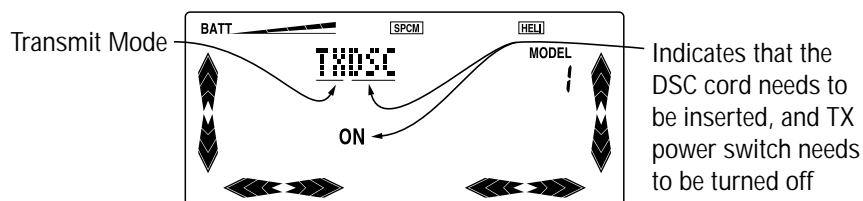

CHAPTER 5: SYSTEM MODE • Helicopter

Transfer Procedure

- Both transmitters: With the main power switch off, press the *Down* and *Channel* keys simultaneously while turning the power switch on to enter the System mode. The word "TXDSC" will be displayed and flashing.
- Press the *Channel* key to select Transmit (TXDSC) or Receive (RXDSC) modes.
- Insert the trainer cord into each transmitter, the letters DSC will be removed from the screen.
- Turn off the power switch on each transmitter. The screen will then change to read either "TXOUT" or "RXSEL", depending if transmit or receive modes were selected.

Note: It is also possible to access the Data Transfer function as follows:

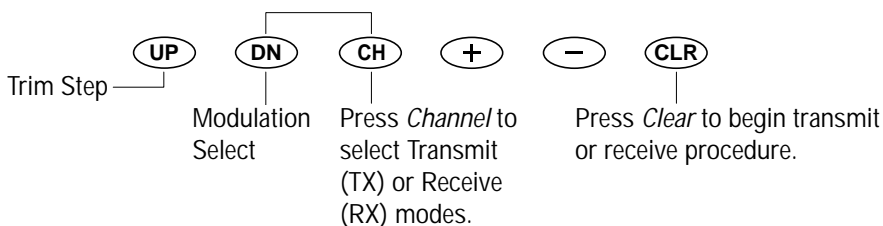
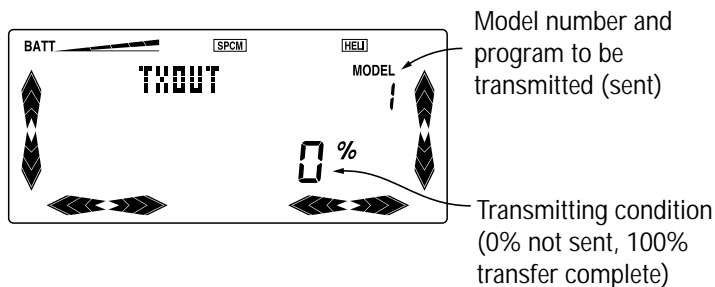

- With the main TX power switch off, press the *Down* and *Channel* keys simultaneously while inserting the trainer cord into the DSC jack of both transmitters. (The transmitters will now be in System mode automatically)
- Press the *Channel* key to select transmit (TX) or receive (RX) modes.
- Both transmitters: In the System mode, press the *Up* or *Down* keys until the words "TXOUT" appears on the screen. This is the Data Transfer program.
- Receiving Mode Transmitter (TX to receive programming): Press the *Channel* key until the screen reads "RXSEL." The word "MODEL" will begin flashing at the top right portion of the LCD directly over the current model number selected.
- Select the receiving model number by pressing the (+) and (-) keys.

Transmitting Data

- Press the *Clear* key to activate the receiving standby mode. The word "RX IN" will now be indicated on the screen.



CHAPTER 5: SYSTEM MODE • Helicopter

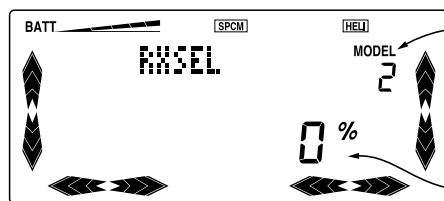

"MODEL" flashing indicates current receiving model number can be selected using the (+) or (-) keys

Indicates receiving condition (0% not started, 100% completed)

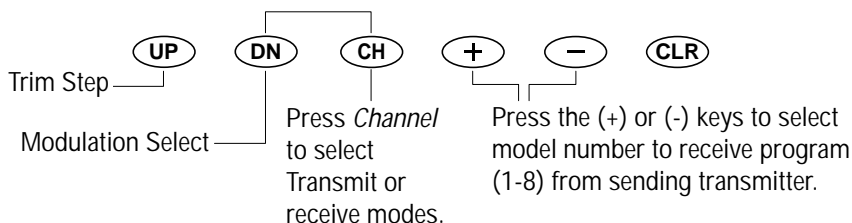

The receiving transmitter must be in this Standby mode before the sending transmitter's *Clear* key is

pressed, or the data will not be transferred successfully.

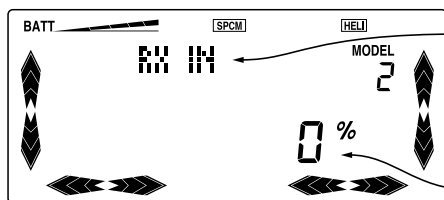

Press the *Clear* key to put the receiving transmitter into Standby mode. The screen will display "RX IN".

Current receiving condition (0% not started, 100% completed)

8. Transmitting mode transmitter (TX with program to be sent): Press the *Clear* key to start transmitting data. If the data transfer was successful, both transmitters will indicate the value 100% on the display when the transmitting is complete.

When the receiving counter is stopped or you see "ERROR" indicated, check the trainer cord connection and condition and try again. Be sure that the receiving Mode transmitter is in standby condition first. Then on the transmitting transmitter press the *Clear* key to start transmitting.

If there is a data receiving error during transmitting, the counter will stop. At this time, press the *Clear* key to stop the receiving function. If there is any failure of transferring, the display will appear as follows:

Note: The Data Transfer function will not work when the battery alarm is flashing.

RXERR RXUER



CHAPTER 5: SYSTEM MODE • Helicopter

5.10 TRIM STEP

The Trim Step function allows the user to increase or decrease the coarseness of the servo movement as compared to the steps or beeps of the digital trim. The total servo trim movement remains the same, (approx. 30degree) regardless of the trim step rate selected (1~10). The factory default setting for the trim step function is 4, which means that for each

step (beep) of the digital trim, the servo will move in digital increments of 4. In other words, if a finer trip step value of 1 is selected, the servo will move in a digital increment of 1 for each step (beep) of the digital trim. If a more coarse trim value of 10 is selected, the servo will move in a digital increment of 10 for each step (beep) of the digital trim lever.

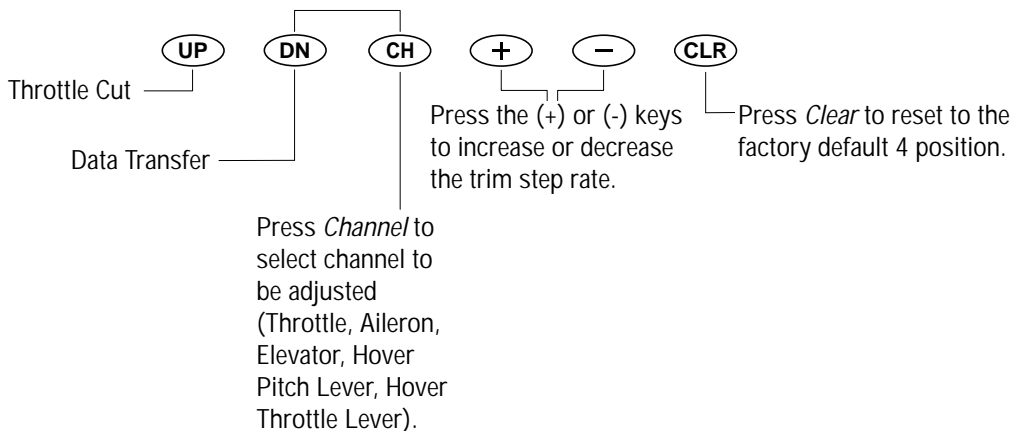
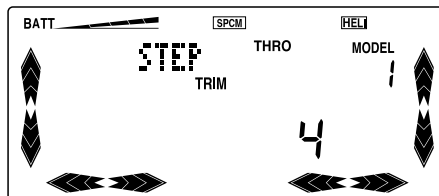

CHAPTER 5: SYSTEM MODE • Helicopter

5.11 THROTTLE CUT SWITCH ACTIVATION

This is the function to assign Throttle Cut switch to the push button located on upper front of the transmitter. In the System mode, select the Throttle Cut Switch function (CUT) by using *Up* or *Down* keys, and press (+) or (-) keys to select the function on or

off. The Throttle Cut function is designed to return the throttle trim to the lowest position instantly and keep this position while the button is pressed. This feature is used to “cut” or stop the engine without changing the position of digital throttle trim.

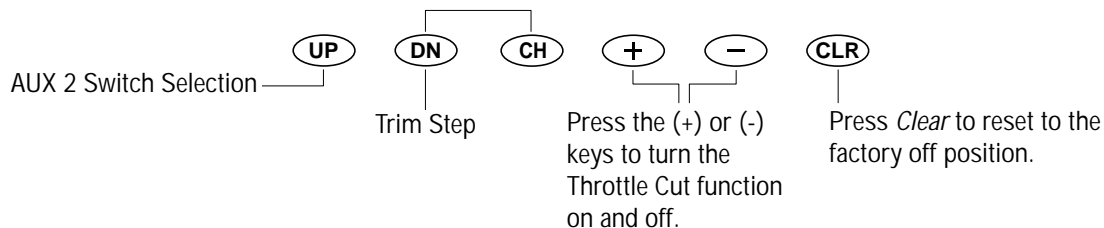
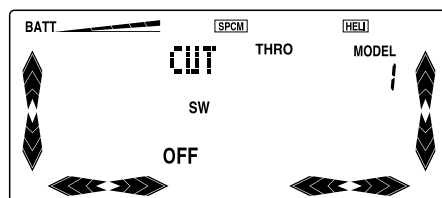

CHAPTER 5: SYSTEM MODE • Helicopter

5.12 AUX2/GEAR FUNCTION SELECT

The AUX 2/Gear channel input selection function allows you to select which switch, AUX 2 or Flight mode, will activate the AUX 2 function, as well as activating or inhibiting the Gear switch. If you use the AUX 2 function for the gyro sensitivity adjustment, you can change the rudder dual rate and the gyro

sensitivity at the same time via the Flight mode switch. Conversely, if the AUX 2 switch is used, the gyro sensitivity is changed when the AUX 2 switch is activated.

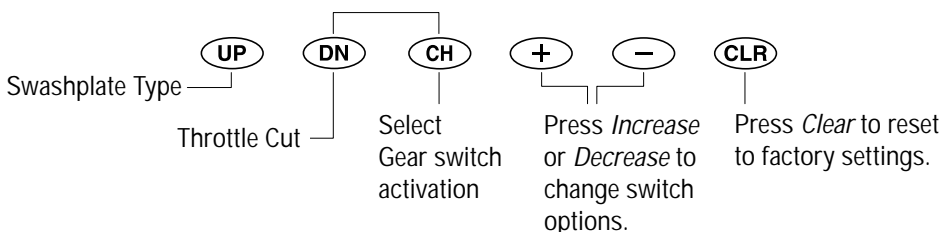
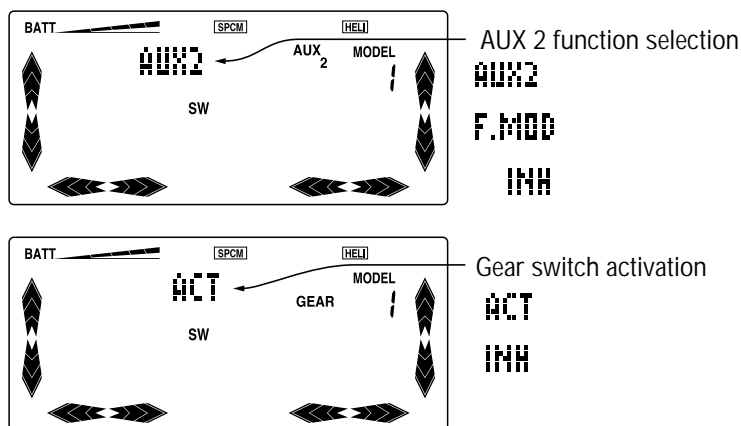

Accessing the AUX 2 Channel Input Selection Function

1. While pressing the *Down* and *Channel* keys, switch the transmitter to the on position to enter the System mode.
2. Press either the *Up* or *Down* key until "AUX2" is displayed in the center portion of the LCD.
3. Pressing either the *Increase* or *Decrease* keys will change the activation switch from the AUX 2 switch to the Flight mode.
4. Pressing the *Clear* key will reset the AUX 2 activation switch to the AUX 2 switch.
5. Pressing the *Channel* key will select the Gear channel switch activation.
6. Pressing either the *increase* or *decrease* keys will change the switch assignment from INH to Act.
7. Pressing the *Clear* key will rest the Gear switch to the ACT (Active) position.
5. To access the Throttle Cut switch function, press the *Down* key.
6. To access the Swashplate Type function, press the *Up* key.
7. To exit the AUX 2/Gear channel input selection function, press the *Down* and *Channel* keys simultaneously.



CHAPTER 5: SYSTEM MODE • Helicopter

5.13 SWASHPLATE TYPE

The Swashplate Mixing function enables the X-378 system to operate many different types of swashplate control systems, including 3 versions of CCPM.

The Swashplate options are:

- 1 Servo: Non-CCPM, standard mixing type helicopter.
- 2 Servo/180° CCPM
- 3 Servo/120° CCPM (JR style, most popular)
- 3 Servo/90° CCPM

Note: Although the X-378 Swashplate Mixing Type screen displays 4SERV 90 CCPM mixing, this function is actually 3 Servo/90° CCPM mixing, and cannot be used with current 4 Servo/90° CCPM models.

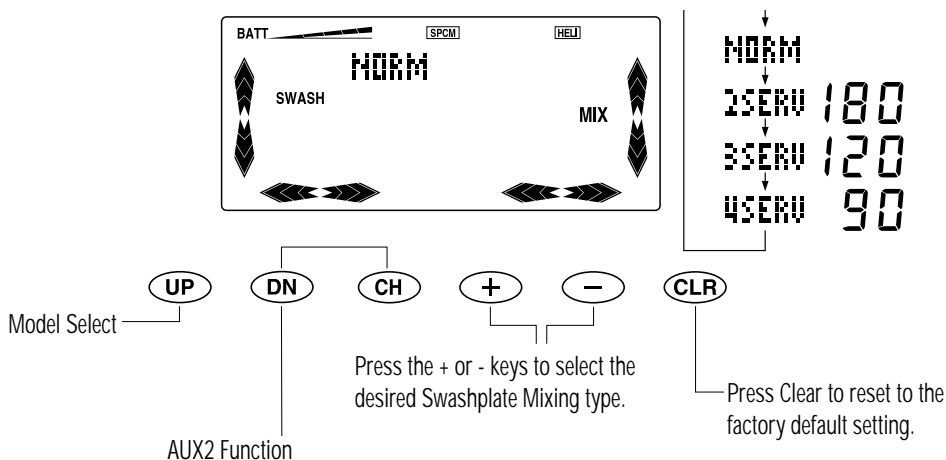

Accessing the Swashplate Type Function

1. While pressing the *Down* and *Channel* keys, switch the transmitter to the ON position to enter the system mode.
2. Press either the *Up* or *Down* key until SWASH is displayed in the left center portion of the LCD.
3. Press the *Increase* or *Decrease* keys to change the Swashplate type.
4. Pressing the *Clear* key will reset the Swashplate Type to the Normal position.
5. Pressing the *Channel* key will select the Gear Channel switch activation.
6. Pressing the *Clear* key will rest the Swashplate Type to the factory default (Normal) position.
7. To access the AUX2 Switch function, press the *Down* key.
8. To access the Model Select function, press the *Up* key.
8. To exit the Swashplate Type function, press the *Down* and *Channel* keys simultaneously.

CHAPTER 6: FUNCTIONS (FUNCTION MODE) • Helicopter

6.1 FUNCTION MODE

To enter the Function mode, switch the transmitter power switch to the On position. Press the *Down* and *Channel* keys simultaneously, and the display will show the last active program. Pressing either the *Up* or *Down* key then scrolls through the functions one by one, according to the Function Mode Flowchart shown on the right. Once the appropriate function is displayed, changes can be made by pressing the (+) or (-) keys. To select another channel of a particular function, press the *Channel* key. If you transfer to a different function that is channel selectable, the display will show the same channel. For example, if you are adjusting the dual rate of the elevator and you change to the Exponential function, the channel remains elevator. The Function mode is the most often used system to input data.

Function Mode Flowchart

Information pertaining to each function is explained on the page listed next to the function name. Functions will appear in the same order they are shown on this chart.

Accessing the Function Mode

1. Move the power switch to the On position.
2. Press the *Down* and *Channel* keys simultaneously.
3. Use either the *Up* or *Down* to scroll through the menu and access the applicable function.

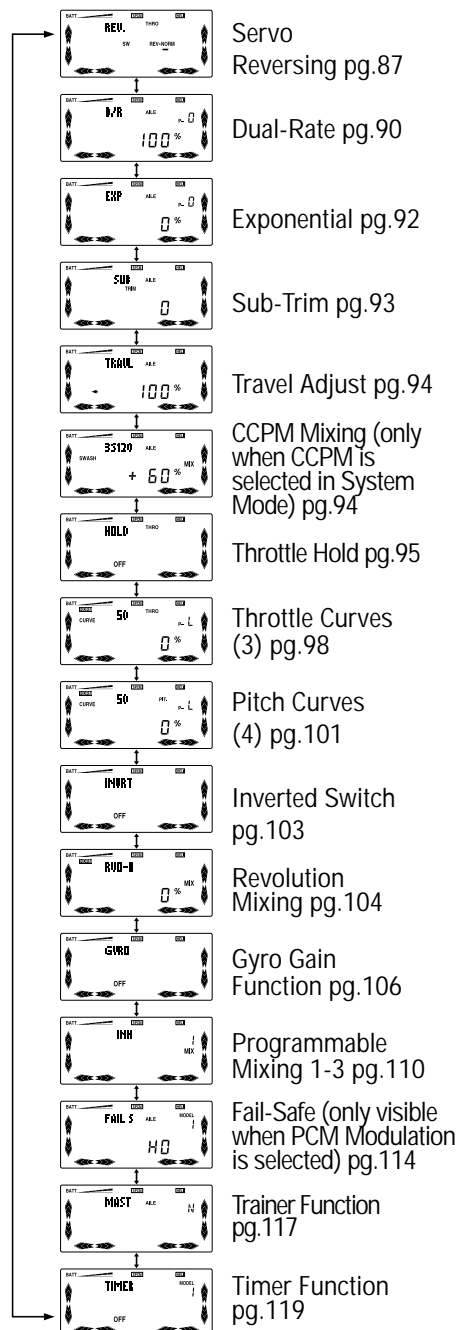
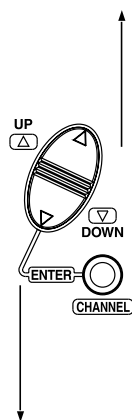

CHAPTER 6: FUNCTIONS (FUNCTION MODE) • Helicopter

6.2 SERVO REVERSING

The Reverse Switch function is an electronic means of reversing the throw of a given channel (servo). All seven channels of the X-378 offer reversible servo

direction. This will ease setup during the servo installation into your aircraft.

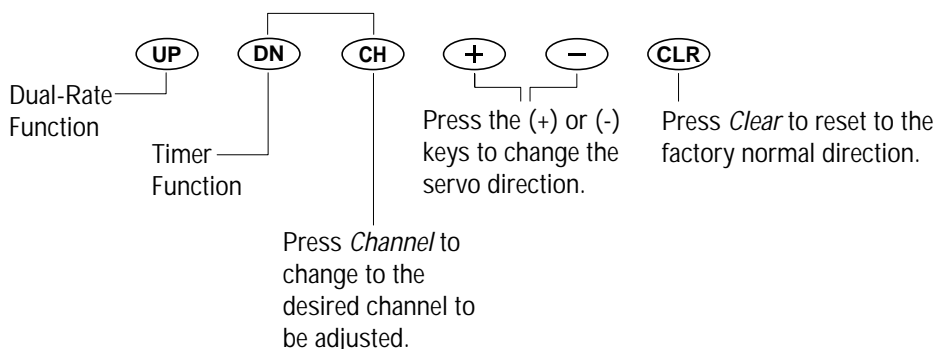
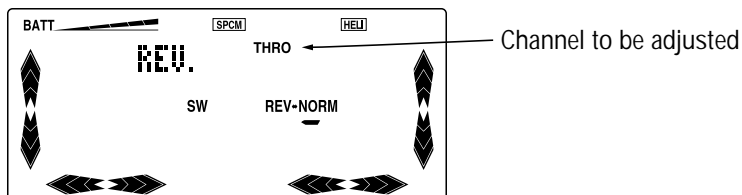

Accessing the Reverse Switch Function

1. Place the transmitter switch in the on position.
2. Access the Function mode by pressing the *Down* and *Channel* keys simultaneously.
3. Press either the *Up* or *Down* key until the "REV." appears in the upper left corner of the LCD.
4. Using your transmitter's control sticks, switches and potentiometers, move the control surfaces of your aircraft. Note the travel direction of each of the corresponding control surfaces.
5. After you have determined which channel(s) need to have the throw directions reversed, use the *Channel* key to call up the appropriate channel.
6. Press either the (+) or (-) keys to change the travel direction of the servo. Pressing the *Clear* key returns the travel direction to normal.
7. You can observe the change in the travel direction by moving the appropriate control at this time.
8. To access the Timer function, press the *Down* key.
9. To access the Dual-Rate function, press the *Up* key.
10. To exit the Reverse Switch function, press the *Down* and *Channel* keys simultaneously.



CHAPTER 6: FUNCTIONS (FUNCTION MODE) • Helicopter

6.3 DUAL RATES

Dual rates are available for the aileron, elevator and rudder channels of your R/C aircraft. There is also an automatic dual rate setting to link your aileron, elevator, and rudder dual rates to the flight model switch. This Automatic Dual-Rate function is discussed in a separate section that follows. Dual rates may be defined as the ability to vary the travel or throw rate of a servo from a switch. Due to the differing travel rates, you will find that the sensitivity

of the control either increases or decreases accordingly. A higher rate or travel yields a higher overall sensitivity. You may find it easier to think of the Dual-Rate function as double-rates or half-rates. The Dual-Rate function works in conjunction with the Exponential function to allow you to precisely tailor your control throws. You may want to consult the section defining exponential for further information.

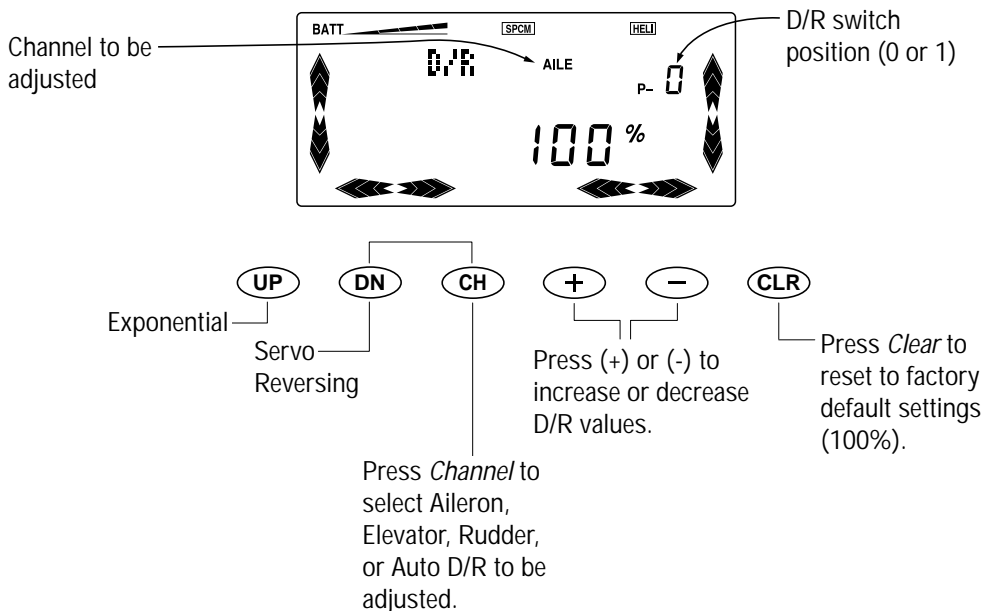

The amount of travel is adjustable from 0-125% in 1% increments. The factory setting, or default value, for both the 0 and 1 switch positions is 100%. Either

switch position may be selected as the low or high rate by placing the switch in the desired position and adjusting the value accordingly.

Accessing the Dual Rate Function

1. Place the transmitter power switch in the on position.
2. Access the Function mode by pressing the *Down* and *Channel* keys simultaneously.
3. Press either the *Up* or *Down* key until "D/R" appears in the upper left corner of the LCD.
4. Press the *Channel* key until the desired channel (aileron, elevator, rudder or automatic dual rates) appears.
5. Select the switch position for which you want to adjust the rate. The number to the upper right of the current rate value on the display indicates the current position of the dual rate switch for the

- channel that you have selected. Either a 0 or a 1 will be shown, corresponding to the position of the switch. To select the opposite switch position, move the appropriate dual rate switch to the opposite position. The number that appears above the current rate value reflects the change.
6. Adjust the rate for the channel and the switch position that you have just selected. To decrease the throw rate, press the (-) key. To increase the throw rate, press the (+) key. As stated previously, the adjustable rate is from 0-125% for each switch position and channel.



CHAPTER 6: FUNCTIONS (FUNCTION MODE) • Helicopter

Accessing the Dual Rate Function (continued)

Note: You can observe the servo changes by moving the respective stick while increasing or decreasing the values. The control changes accordingly. To clear the dual rate for the respective channel and switch position, press the *Clear* key. After the dual rates have been dialed in to your satisfaction, we suggest that you begin to adjust the exponential values. Refer to the Exponential section for more information.

7. To access the Servo Reversing function, press the *Down* key.
8. To access the Exponential function, press the *Up* key.
9. To exit the Dual-Rate function, press the *Down* and *Channel* keys simultaneously.

Automatic Dual Rate

If the Automatic Dual-Rate function AUTO is active (on) when switching the flight mode switch, aileron,

elevator and rudder channel Dual-Rate values are switched to preset values settled by position 1.

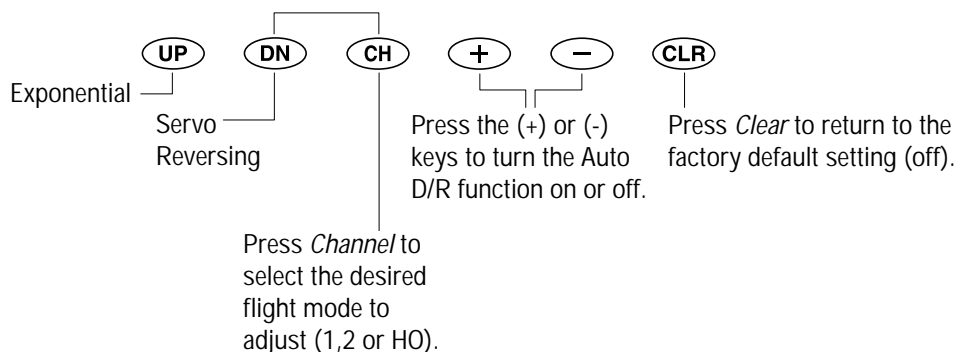
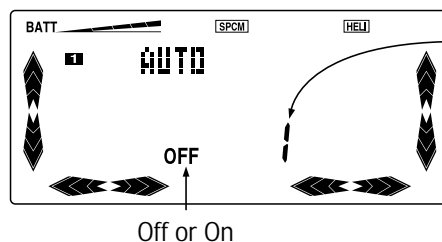

To access this function, move to the D/R (Dual-Rate) screen, and press the Channel button until the word "AUTO" appears at the top center of the screen, with a small box with the number 1 to the far left. This would indicate the Auto D/R function for Flight mode 1. Press the (+) or (-) keys to turn the function on or off. Repeat this procedure for flight modes 2 and

Hold (HO). To confirm that the Auto D/R is functioning, simply move the flight mode switch while at any of the normal D/R channel screens. If the Auto D/R is functioning, the screen will indicate "D/RAT", and the D/R switch position at the far right of the screen will change from 0 to 1 as the switch is moved.

CHAPTER 6: FUNCTIONS (FUNCTION MODE) • Helicopter

6.4 EXPONENTIAL

Programmable exponential adjustments are offered on the aileron, elevator, and rudder channels of your R/C aircraft. Exponential is a function that allows you to tailor the response rate of the stick controls. The purpose of exponential is to reduce the sensitivity in the middle portion of stick movement, while still allowing full travel at the end of the stick movement. In other words, the end result (travel) remains the same, although exponential changes the rate at which it achieves this travel.

The adjustable range of the Exponential Function is from 0-100%. Zero percent (0%) is linear stick control

which means that the response rate is equal throughout the stick control. 100% is full exponential. The larger the exponential value, the less servo action or sensitivity you will notice around the neutral setting.

Note: The Exponential function operates in conjunction with the Dual-Rate function. It is imperative to understand the Dual-Rate function prior to adjusting the exponential values. Exponential may be selected for either the high or low rate or both.

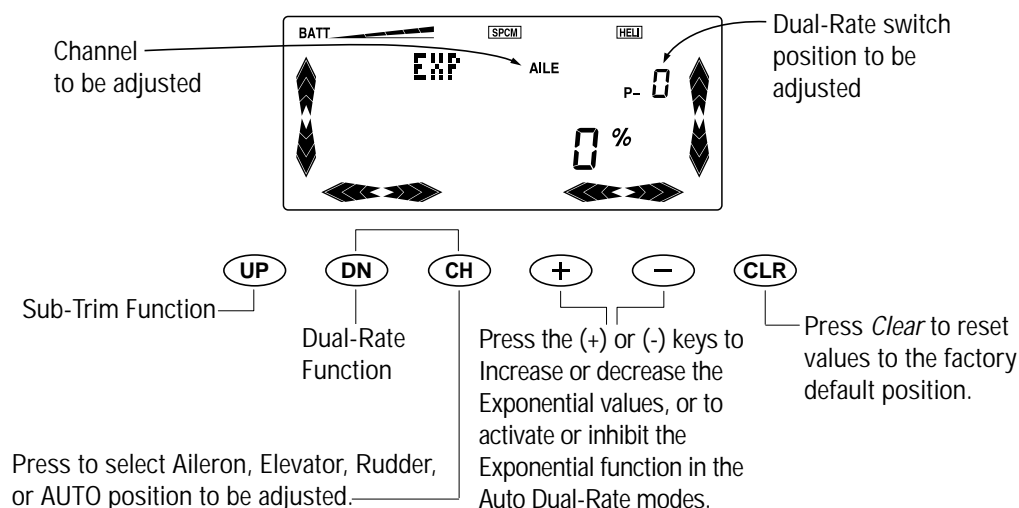

Accessing the Exponential Function

1. Place the transmitter power switch in the On position.
2. Press the *Down* and *Channel* keys simultaneously to access the Function mode.
3. Press either the *Up* or *Down* key until "EXP" (Exponential) appears in the upper left corner of the LCD.
4. Press the *Channel* key until the desired channel (aileron, elevator, rudder or AUTO) appears.
5. Select the switch position for which you want to adjust the exponential rate. The number directly above the exponential value on the display indicates the current position of the dual rate switch for the channel that you have selected. Either a 0 or 1 will be shown, corresponding to the position of the switch. To select the opposite switch position, move the appropriate Dual-Rate or Flight mode switch to the opposite position. The number that appears directly
6. Adjust the rate for the channel and the switch position that you have just selected. To increase the exponential rate, press the (+) key. As stated previously, the adjustable rate is from linear (0%) to 100% for each switch position and channel.

Note: Exponential is an acquired feel. As such, it may take several test flights to achieve the proper amount of exponential that fits your flying style.

8. To access the Dual-Rate function, press the *Down* key.
9. To access the Sub-Trim function, press the *Up* key.
10. To exit the Exponential Function, press the *Down* and *Channel* keys simultaneously.

CHAPTER 6: FUNCTIONS (FUNCTION MODE) • Helicopter

6.5 SUB-TRIM

The Sub-Trim Adjustment function allows you to electronically fine-tune the centering of your servos. Individually adjustable for all seven channels with a range of $\pm 125\%$ (± 30 degrees servo travel), the sub-trims can be set for the same neutral settings for

each model stored in the transmitter's memory. The sub trim functions provides precise servo arm neutral positioning if rotating the servo arm will not allow the desired servo arm position.

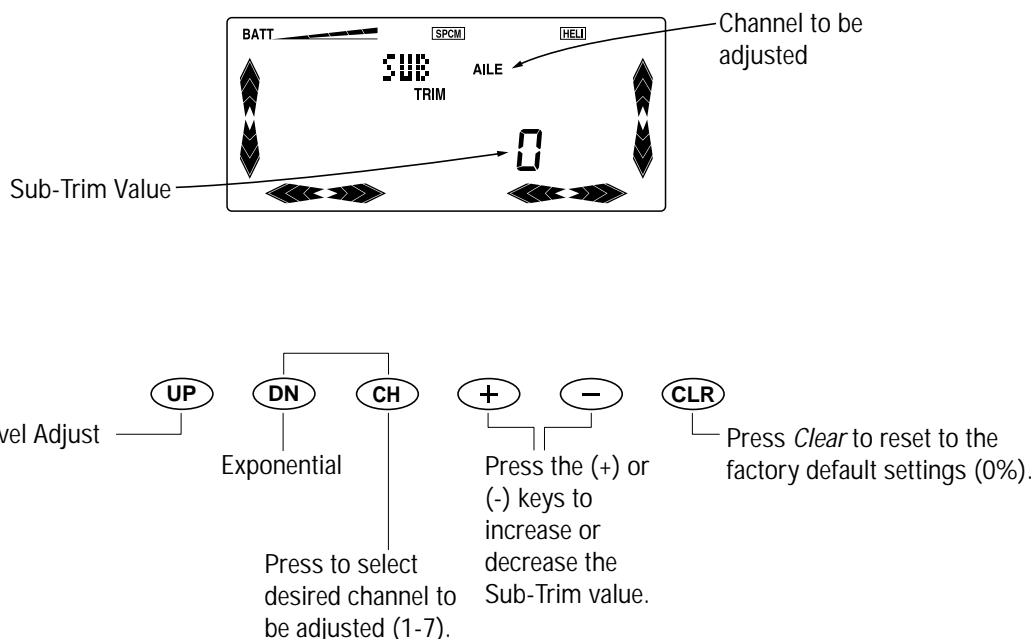

Accessing Sub-Trim Adjustment Function

1. Place the transmitter power switch in the On position.
2. To access the Function mode, press the *Down* and *Channel* keys simultaneously.
3. Press either the *Up* or *Down* key until "SUBTRIM" appears in the upper middle portion of the LCD.
4. Press the *Channel* key until the desired channel appears.
5. Press the (+) or (-) key to establish the desired amount and direction of Sub-Trim.

Note: A (+) or (-) symbol appears to the left of the sub trim value to indicate the direction of Sub-Trim input.

Caution: Do not use excessive sub-trim adjustments since it is possible to overrun your servo's maximum travel if it is off-center. Remember that it is a trim convenience function. It is not intended to take the place of the proper mechanical trim adjustments that are necessary on any R/C model. An offset servo will also produce a differential effect.

6. To access the Exponential function, press the *Down* key.
7. To access the Travel Adjust function, press the *Up* key.
8. To exit the Sub-Trim function, press the *Down* and *Channel* keys simultaneously.

CHAPTER 6: FUNCTIONS (FUNCTION MODE) • Helicopter

6.6 TRAVEL ADJUST

The purpose of travel adjust, also known as endpoint adjustment or adjustable travel volume, is to offer you precise servo control deflection in either direction of servo operation. The X-378 offers travel adjust for all seven channels. The travel adjust range

is from 0-150% (0 degrees to 60 degrees) from neutral, or center, and it can be adjusted for each direction individually. The factory default (data reset) value is 100% for each direction of servo travel.

Travel direction to be adjusted (left/Right, Up/Down, etc)

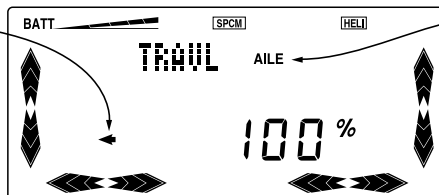

Channel to be adjusted

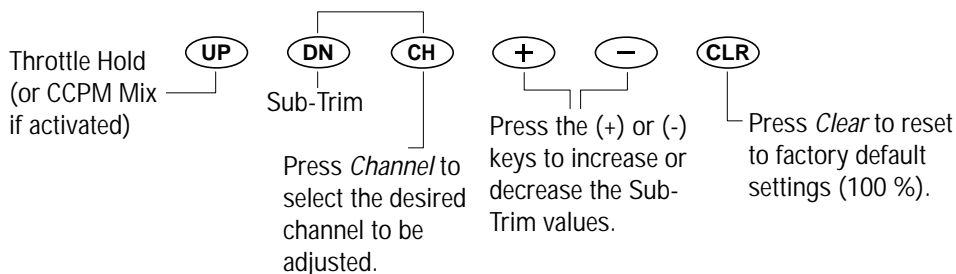

Accessing the Travel Adjust Function

1. Place the transmitter power switch in the On position.
2. Access the Function mode by pressing the *Down* and *Channel* keys simultaneously.
3. Press either the *Up* or *Down* key until "TRAVL" appears in the upper middle portion of the LCD.
4. Press the *Channel* key until the desired channel appears.
5. Move the appropriate control stick (lever, switch, etc) to the right or left of center to the direction of travel you want to adjust. An arrow to the right of the travel adjust value will reflect the current position to be adjusted. Using our example above, if the aileron stick is moved to the left, a left-facing arrow will appear to the left of the travel adjust value on the LCD screen.
6. After the control stick or switch is placed in the direction of travel to be adjusted, press the (+) or (-) key until the proper amount of servo travel is shown on the lower right side of the LCD. Press the (+) key to increase the amount of servo travel. Press the (-) key to decrease the amount of servo travel.
7. Follow the same procedure for the remaining channels.
8. To access the Sub-Trim function, press the *Down* key.
9. To access the Throttle Hold (or CCPM Mix if activated) function, press the *Up* key.
10. To exit the Travel Adjust function, press the *Down* and *Channel* keys simultaneously.



CHAPTER 6: FUNCTIONS (FUNCTION MODE) • Helicopter

6.7 CCPM SWASHPLATE MIXING

Note: The CCPM Swashplate Mixing screen is only displayed when Swashplate types 2Serv, 3Serv or 4Serv CCPM are selected in the Swashplate type Selection in System Mode.

If The Swashplate Type option has not been selected, proceed to section 6.7 Throttle Hold.

The CCPM Swashplate Mixing Function (Cyclic Collective Pitch Mixing) of the X-378 is designed to allow the X-378 to be used in model helicopters that utilize 2-servo (180°), 3-servo (120°) and 3-servo (90°) type swashplate control system.

The desired swashplate mixing type must first be selected at the Swash Type Selection in System Mode.

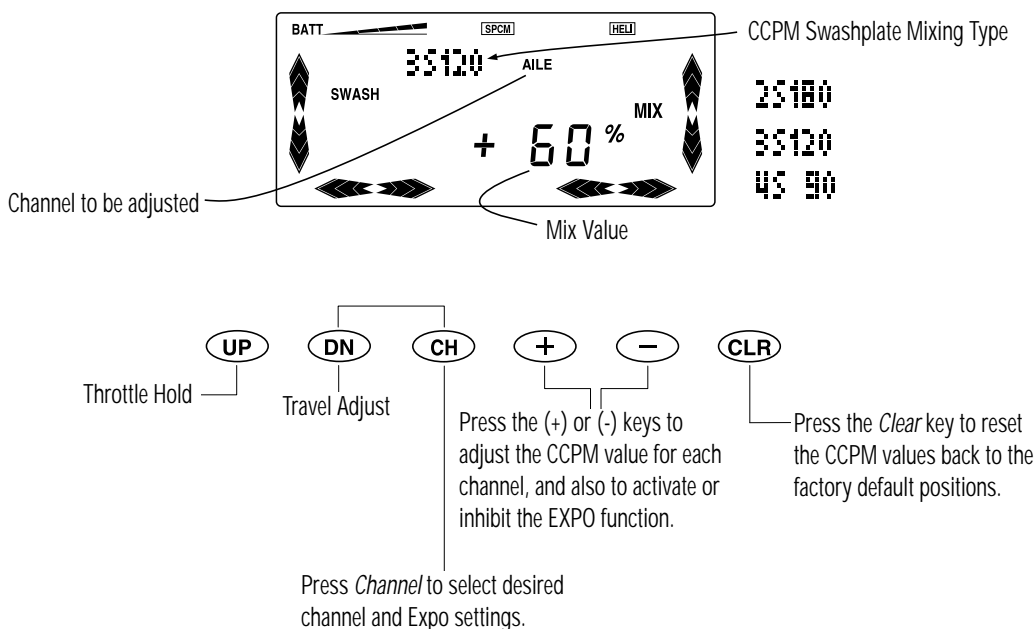

Accessing the Swashplate Type

1. Place the transmitter power switch in the ON position.
2. Access the Function Mode by pressing the *Down* and *Channel* keys simultaneously.
3. Press either the UP or DN key until SWASH appears in the middle left portion of the LCD.
4. Press the *Channel* key until the desired channel appears.
5. Press the + or - Keys to Increase or Decrease the CCPM Values, or to access the EXPO function
6. Follow the same procedure for the remaining channels.
8. To access the Travel Adjust Function, press the *Down* key.
9. To access the Throttle Hold Function, press the *Up* key.
10. To exit the Swashplate Type Function, press the *Down* and *Channel* keys simultaneously.

CHAPTER 6: FUNCTIONS (FUNCTION MODE) • Helicopter

CCPM Swashplate Mixing (continued)

CCPM is a type of pitch mixing where the two or three servos are connected directly to the swashplate of the helicopter and physically move both together

and independently for all changes in pitch/cyclic. Please refer to the diagram below.

CCPM Servo Variations

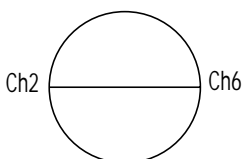

2 Servo/180° CCPM

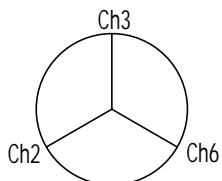

3 Servo/120° CCPM
(JR style, most popular)

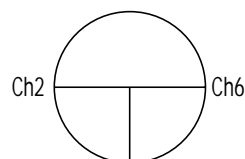

3 Servo/90° CCPM

1). 1 servo (Standard Mechanical Mixing)

The most common form of Swashplate Mixing. This type uses each of the three servo to move the swashplate individually for pitch, Aileron, and Elevator changes. If one servo(NORM) is selected in the System Mode (Factory Default), the Swashplate Type Function will not appear on the LCD screen in this section.

2). 2 servo(180degrees)

2 servos are used to move the swashplate, and are spaced at 180degrees apart. This is not a very common control system configuration.

3). 3 servo(120degrees)

3 servos are used to move the swashplate, and are spaced at 120degrees apart. This is the most common form of CCPM, and is found in JR and other brands of Helicopters.

4). 3 servo(90degrees)

3 servos are used to move the swashplate, and are spaced at 90degrees apart. This is also not a very common control system configuration.

Note: Although the display of the X-378 indicates 4 Servo 90° CCPM, this is actually 3 Servo 90° CCPM as mentioned above. 3 Servo 90° CCPM can not be used with a 4 Servo 90° CCPM control system.

CCPM Servo Connection/ Channel Numbers

2 servo(180°) 3 servo(120°) 3 servo(90°)

Ch 2 Aileron	Ch 2 Aileron	Ch 2 Aileron
Ch 2 Elevator	Ch 3 Elevator	
Ch 6 Pitch	Ch 6 Pitch	Ch 6 Pitch

Exponential (EXP)

The purpose of this exponential is to remove the non-linear, or rough movement of the swashplate due to the mechanical differential of the servo horn. This will be a help to change circular movement of servo horn to linear movement. The Exponential function can be turned on and off by selecting the EXP function with the *Channel* key, and then pressing the (+) or (-) keys .



CHAPTER 6: FUNCTIONS (FUNCTION MODE) • Helicopter

6.8 THROTTLE HOLD

The Throttle Hold function is designed to hold the throttle servo in a specific position during an autorotation. This is very useful for practicing autorotation landings. The throttle hold switch is

located on the top right-rear corner of the transmitter. The throttle hold is on in the forward switch position; in the rear position, the Throttle Hold is off.

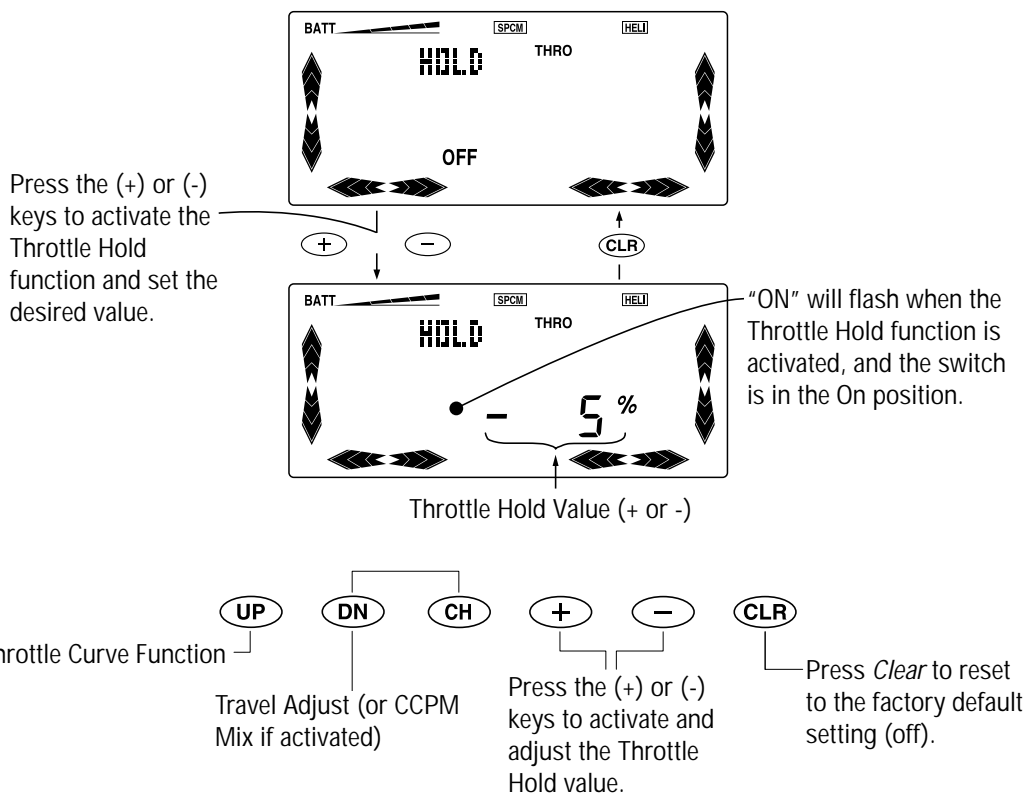

Accessing the Throttle Hold Function

1. Place the transmitter switch in the on position.
2. Press the *Down* and *Channel* keys simultaneously to enter the Function mode.
3. Press either the *Up* or *Down* key until "HOLD" appears at the top center of the LCD.
4. The factory setting for the throttle hold is off. Pressing either the (+) or (-) key will activate Throttle Hold and display the current throttle hold value.
5. Using the (+) or (-) key, adjust the throttle hold value to deliver the proper engine idle rpm for your helicopter. The adjustable range is (-20%+50%). Once you establish the proper idle value for your engine, you can use this value for throttle hold as well. To shut the

engine off for autorotation, a negative or zero value should be input.

Note: When the throttle hold is activated, and the switch is on, the "ON" indication on the LCD flashes.

6. To access the Travel Adjust (or CCPM Mix if activated) function, press the *Down* key.
7. To access the Throttle Curve function, press the *Up* key.
8. To exit the Throttle Hold function, press the *Down* and *Channel* keys simultaneously.

CHAPTER 6: FUNCTIONS (FUNCTION MODE) • Helicopter

6.9 THROTTLE CURVES

The X-378 offers three (3) separate throttle curves with five adjustable points per curve. This function allows you to customize the throttle curve and pitch curve together to maximize engine performance at a particular pitch setting. Once the throttle curves are established, each can be activated in flight using the three (3) position flight mode switch.

The flight mode switch offers three selectable ranges: N=Normal, 1=Stunt-1, and 2=Stunt-2. The N (Normal) position should be used as the hover throttle curve. Positions 1 and 2 (Stunt-1 and Stunt-2) should be used for aerobatic maneuvers and forward flight.

Note: The throttle trim and hovering throttle levers are only operable when the flight mode switch is in the normal position. Thus, in the 1 or 2 positions, these two functions have no effect. Also, adjusting the hovering throttle lever and throttle trim has no effect on the input values of the throttle curve.

Each of the five points of the throttle curve are independently adjustable from 0-100%. These five points correspond to the position of the throttle stick. The illustration below shows the normal throttle curve setting for the dead slow position with throttle trim at default.

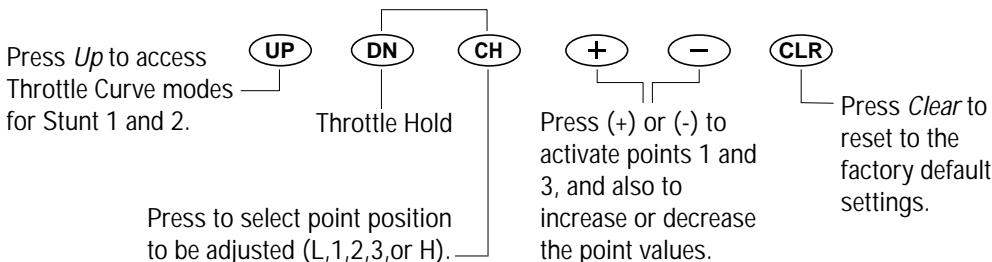
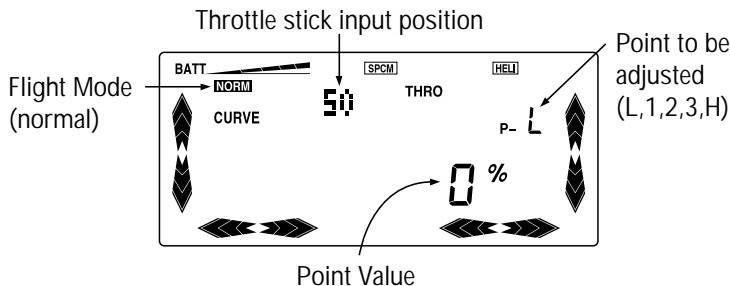

The transmitter is factory preset to the throttle curve as indicated by the solid line in the figure at right. Individual middle points can be increased or decreased to suit your specific needs.

The throttle trim lever position will affect the low-point position as shown when in the Normal mode Throttle Curve.

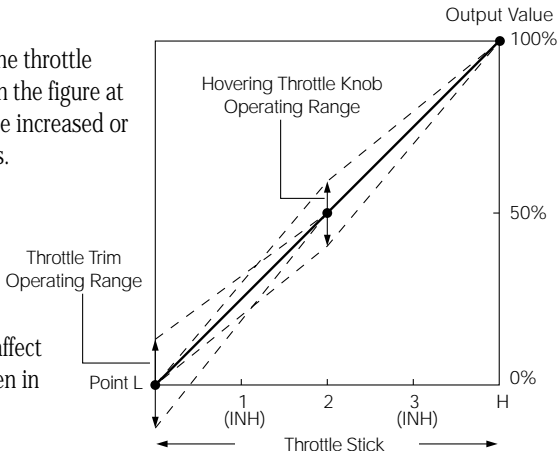

CHAPTER 6: FUNCTIONS (FUNCTION MODE) • Helicopter

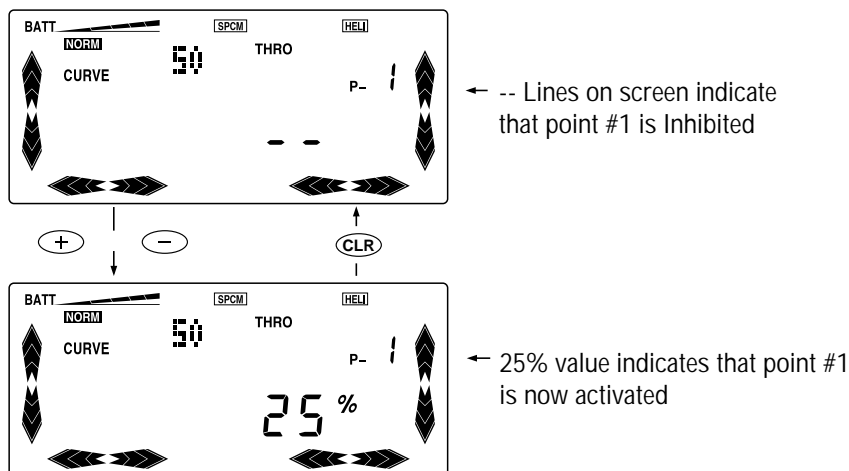

Accessing the Throttle Curve Function

1. Place the transmitter switch in the On position.
2. Press the *Down* and *Channel* keys simultaneously to enter the Function Mode.
3. Press either the *Up* or *Down* key until "THRO" appears in the upper right portion of the LCD.

Note: The characters directly under the battery graph at the top left of the LCD is the Flight mode switch position curve currently being adjusted. Use NORM for hover curves and 1 and 2 for stunt curves. We will concentrate on the hovering curve during this example.

4. Press the *Channel* key to select the point of the curve you want to change.
5. Press either the (+) or (-) key to change the value of the current curve point. The range of each point is 0-100% in .5% intervals.

Note: In each curve, the factory setting indicates INH for points 1 and 3. These values

are 25% and 75% respectively if no value changes are made to any other points. If any of the other points have been changed while these points were inhibited, the inhibited points will also change to plot a smooth curve. If you want to keep this from happening, press the *Channel* key until the display indicates P-1 or P-3 at the upper right portion of the LCD. Press either the (+) or (-) key to activate the points 1 (25%) or 3 (75%). The values for each of these curves can then be fully adjusted by pressing either the (+) or (-) key.

6. To set curves for flight mode switch position 1, press the *Up* key once and repeat steps 4 and 5.
7. To set curves for flight mode switch position 2, press the *Up* key once and repeat steps 4 and 5.
8. To access the Throttle Hold function, press the *Down* key until "HOLD" is displayed.
9. To exit the Throttle Curve function, press the *Down* and *Channel* keys simultaneously.

Throttle Trim Settings

The throttle trim lever is only active when the flight mode switch is in the normal position. The throttle trim is used to increase or decrease the engine power when the flight mode switch is in the Normal mode. The throttle trim lever has no effect on positions 1, 2, or in throttle hold.

Note: Making changes to the throttle trim lever does not change the input values for any of the points on the throttle curve; it merely makes adjustments to the engine idle speed position.

CHAPTER 6: FUNCTIONS (FUNCTION MODE) • Helicopter

Hovering Throttle Lever Setting

The Hovering Throttle lever increases or decreases the engine output power for the middle three points set for the throttle curve. As shown in the figure below, use of the hovering throttle lever shifts the

curve upward or downward parallel with the original curve. Therefore, operation of the hovering throttle knob does not cause any change to the original settings of the throttle curve.

The throttle trim range will affect the throttle curve as shown.

The adjustable range of output using the hovering throttle lever is approximately $\pm 9\%$.

Note: The Hovering Throttle has no effect on flight mode switch positions 1 and 2.

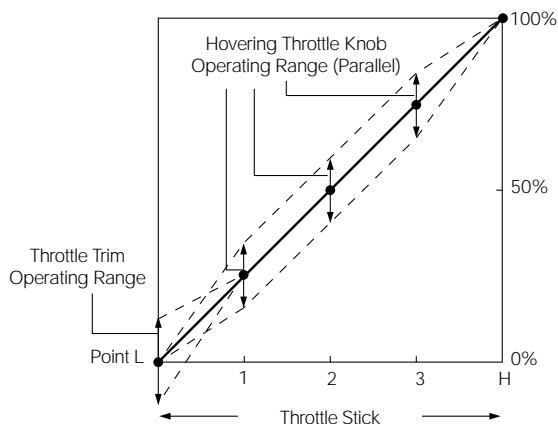

Throttle Curve Exponential

With the X-378 system, individual throttle curves are selectable to be either straight (linear) or curved (exponential) setting. With the exponential function on, you will notice that any sharp angles of the throttle curve will become more “rounded” or “smooth”, creating more equal throttle servo movement during the entire curve range.

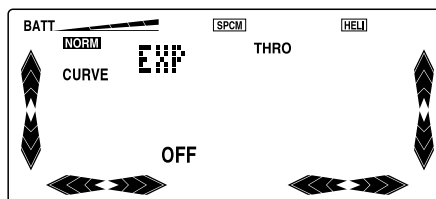

Accessing the Throttle Curve Exponential Function

1. From the Throttle Curve function, press the *Channel* key until “EXP” appears at the center of the LCD screen.
2. Press the (+) or (-) keys to turn the Exponential function on or off.
3. To exit the Throttle Curve function, press the *Down* and *Channel* keys simultaneously.



CHAPTER 6: FUNCTIONS (FUNCTION MODE) • Helicopter

6.10 PITCH CURVES

Adjustment of the pitch curve is very similar to the throttle curve adjustment described in the preceding section. A thorough understanding of the Throttle Curve Section will make pitch curve adjustment easier to understand. There are four independent types of pitch curves available: Normal, Stunt-1, Stunt-2 and

Hold. Each pitch curve contains five adjustable points: L, 1, 2, 3 and H.

Note: The pitch curve for the Throttle Hold function can only be set if this system is activated.

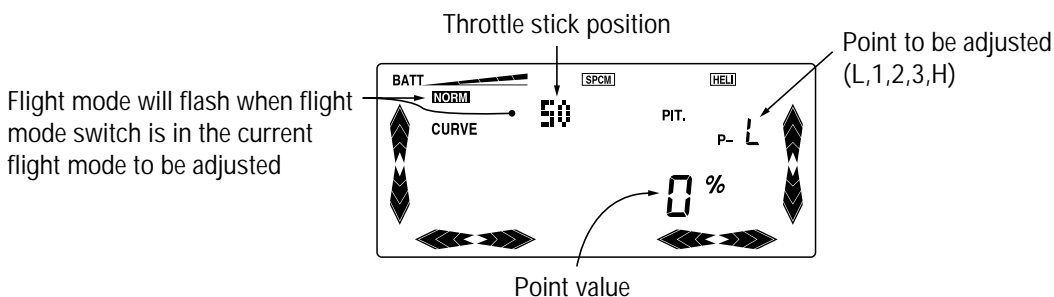

Accessing the Pitch Curve Function

1. Place the transmitter switch in the On position.
2. Press the *Down* and *Channel* keys simultaneously to enter the Function mode.
3. Press either the *Up* or *Down* key until "PIT" appears in the top right portion of the LCD.

Note: The characters directly under the battery graph at the top right portion of the LCD is the flight mode switch position curve currently being adjusted (Normal, 1, 2 or H). Use NORMAL for hover curves and 1 and 2 for stunt curves. We will concentrate on the hovering curve during this example.

4. Press the *Channel* key to select the point of the curve you want to change.
5. Press either the (+) or (-) key to change the value of the current curve point. The range of each point is 0-100% in .5% intervals.

Note: In each curve, the factory setting -- indicates Inhibited for points 1 and 3. These

values are 25% and 75% respectively, if no value changes are made to any other points. If any of the other points have been changed while these points were inhibited, the inhibited points will change to plot a smooth curve. If you want to keep this from happening, press the *Channel* key to display the positions 1 and 3, then press the (+) or (-) key to activate each point.

6. To set curves for Flight mode switch position 1, press the *Up* key and repeat steps 4 and 5.
7. To set curves for flight mode switch position 2, press the *Up* key again and repeat steps 4 and 5.
8. To set the curves for the Throttle Hold mode "H", press the *Up* key once again until "H" is displayed, and repeat steps 4 and 5.
9. To access throttle curve switch position 2, press the *Down* key four times.
10. To exit the Pitch Curve function, press the *Down* and *Channel* keys simultaneously.



CHAPTER 6: FUNCTIONS (FUNCTION MODE) • Helicopter

Hovering Pitch Lever

The Hovering Pitch lever operates in the same manner as the Hovering Throttle knob. It is only operable while the flight mode switch is in the "N" (normal) position, and its function is to shift the middle portion of the curve upward or downward.

Example of Throttle Curve and Pitch Curve Settings

An example of throttle curve and pitch curve settings for aerobatic specifications is shown below in the form of graphs. Details of the curves will differ depending on the helicopter specifications. In these examples, the throttle open-close stroke and autorotation pitch stroke are set 0 to 100 to ease your understanding of other curves.

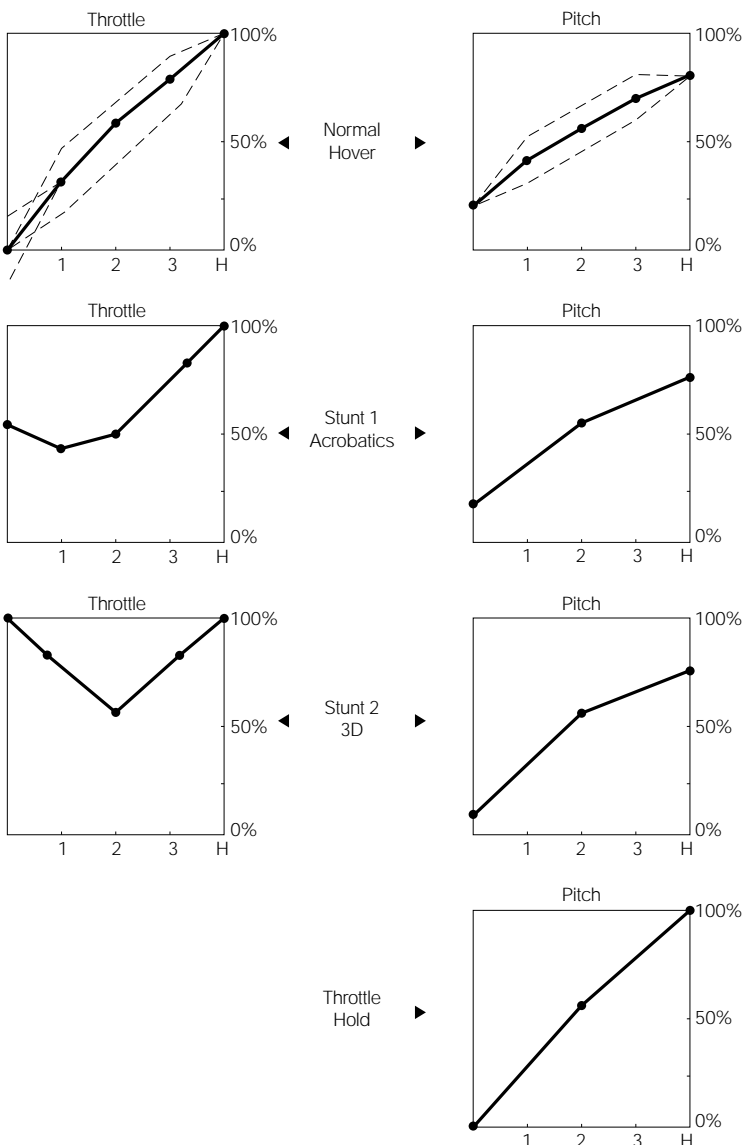

CHAPTER 6: FUNCTIONS (FUNCTION MODE) • Helicopter

6.11

INVERTED SWITCH

The function of the Inverted Flight function electronically reverses several control operations to enable you to fly a helicopter much more easily. The Inverted switch function is seldom used for 3D flying as it was originally designed for. It is recommended that the Inverted function not be used for 3D flying, as it is a better method to learn 3D flying without the aid of this type of function. When the inverted flight switch (located at the top left front portion of the Transmitter) is pulled forward, the Inverted Flight function is switched on. The inverted point is the throttle position at which no collective pitch change will take place when the Inverted Flight function is operated. The higher the value, the further

the throttle/collective stick must be toward full throttle position. The factory preset is 50% and is actually somewhat less than hover throttle since the Inverted Flight function is normally operated with the stick toward the low-throttle position. When the Invert Flight function is activated, collective, rudder and elevator operations are reversed automatically. For inverted hovering maneuvers, the flight mode switch should be left in the N (Normal) position. For inverted aerobatics maneuvers, it is recommended that you set up a pitch curve dedicated to inverted flight. This is most often used in conjunction with Flight mode switch position 2.

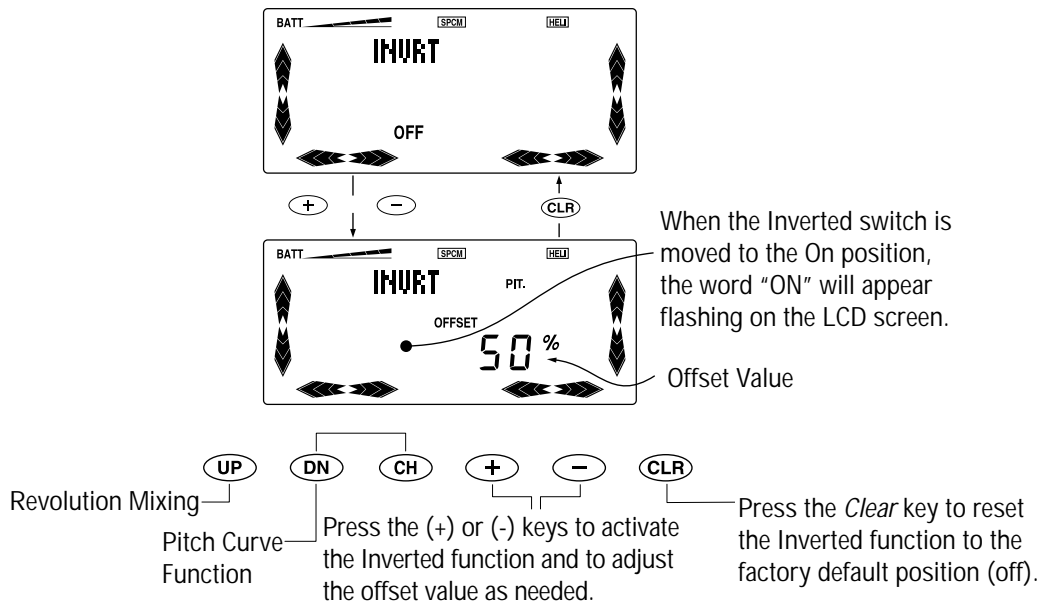

Accessing the Inverted Flight Function

1. Place the transmitter switch in the On position.
2. Press the *Down* and *Channel* keys simultaneously to enter the Function mode.
3. Press either the *Up* or *Down* key until "INVRT" is displayed on the upper left side of the LCD.
4. Pressing either the (+) or (-) key will change the right portion of the display from INH to 50.0%. Pressing either of these keys again will change the value in the appropriate direction. When the Inverted Flight Function is active, the word "OFFSET" will appear below "INVRT." If the invert switch is
5. activated, the word "ON" will flash.
6. To access the Pitch Curve function, press the *Down* key.
7. To access the Revolution Mixing function, press the *Up* key.
7. To exit the Inverted Flight function, press the *Down* and *Channel* keys simultaneously.

Caution: If you do not intend to use the Inverted Flight function, leave this function's operation inhibited.

CHAPTER 6: FUNCTIONS (FUNCTION MODE) • Helicopter

6.12

REVOLUTION MIXING (NON-HEADING LOCK GYROS ONLY)

The Revolution Mixing function mixes tail rotor with the Throttle and Pitch Curve functions to counteract torque from the main rotor blades. When set up correctly, the helicopter should climb and descend without a tendency to yaw in either direction. Because torque reaction varies with different power settings, it is necessary to vary the tail rotor pitch at the same time. The X-378 offers two separate revolution mixing programs, with independent up and down mixing for

each - one for Flight mode position N and the other for Stunt-1 and Stunt-2 positions. The U (Up) mixing adjusts the tail rotor compensation for the mid to high throttle setting and the D, or down, mixing adjusts the tail rotor compensation for the mid to low throttle setting. Thus, if you were to move the throttle from the low to high position, the tail rotor servo would move from D through Hover (mid) and to the U setting.

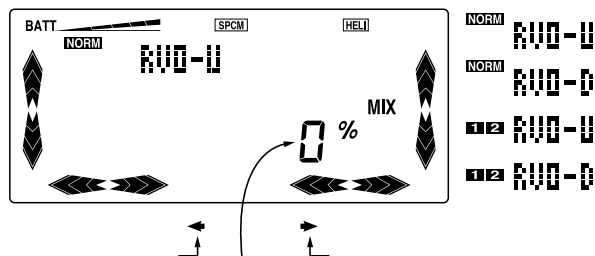

Note: If the Throttle Stick is in the current position being adjusted (Example: Low stick, down (D) mix, the letters "U" or "D" will flash)

When a value is entered, a left or right facing arrow will appear on the LCD screen to indicate the mix direction

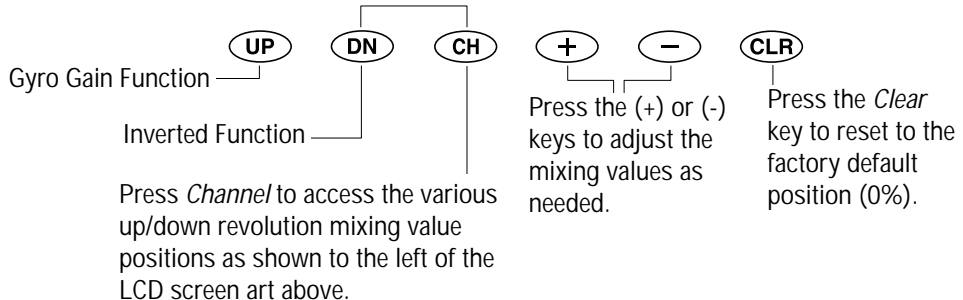

Accessing the Revolution Mixing Function

1. Place the *transmitter* switch in the On position.
2. Press the *Down* and *Channel* keys simultaneously to enter the Function Mode.
3. Press either the *Up* or *Down* key until "RVO-U" appears at the upper portion of the LCD.
4. Pressing the *Channel* key will select Up (U) or down (D) mix and the flight mode switch position. When the flight mode switch is in the displayed position and the throttle stick is in the displayed position, these two characters will flash. For example, when the screen displays "RVO-U, NORMAL, 0%" and the Flight mode switch is in the N position with the throttle below half, the "U" will flash.
5. Press the (+) key to increase the right tail compensation or press the (-) key to increase the left compensation. Press the *Clear* key to reset to 0%.
6. This setup procedure can be used for revolution mixing for either flight mode switch position N or 1 and 2. Switch position 1 or 2 should be used for forward and/or inverted compensation.
7. To access the Inverted Flight function, press the *Down* key.
8. To access the Gyro Gain function, press the *Up* key.
9. To exit the Revolution Mixing function, press the *Down* and *Channel* keys simultaneously.



CHAPTER 6: FUNCTIONS (FUNCTION MODE) • Helicopter

Setting Up Revolution Mixing

Set up the helicopter so that it will hover with the tail rotor trim centered. Establish the helicopter into a stable hover, then steadily increase the throttle to initiate a steady climb. The body of the helicopter will move in the opposite direction to the main rotor rotation. Increase the U, or Up, setting until the helicopter climbs with no tendency to turn. At a safe altitude, close the throttle; the helicopter will descend and the body will turn in the same direction as the main rotor rotation. Increase the D, or down, mix until the helicopter descends with no tendency to turn. Throttle stick movements should be slow, and the initial acceleration and deceleration swings should be ignored.

When throttle is in the hold position (autorotation), revolution and acceleration mixings are off. The Acceleration Mixing function is provided to compensate for the main rotor acceleration (and deceleration) torque. The magnitude and duration of the signal to the tail rotor depends upon the rate of the throttle changes. Thus, quick, jerky throttle inputs will yield more noticeable tail compensation.

Note: The Revolution Mix function must be established before an accurate acceleration mix can be achieved, and the gyro should be switched off.

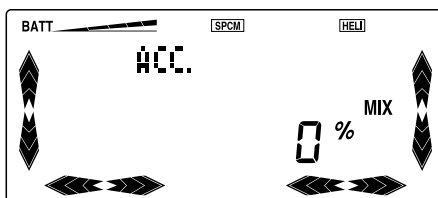

Accessing the Acceleration Mixing Function

1. Place the *transmitter* switch in the On position.
2. Press the *Down* and *Channel* keys simultaneously to enter the Function Mode.
3. Press either the *Up* or *Down* key until "RVO-U" appears at the center of the LCD.
4. Press the *Channel* key until "ACC." appears at the center of the LCD.
5. Using the (+) or (-) key, increase or decrease the acceleration mix until no tail swing is noticed when the throttle is increased or decreased abruptly.
6. To access the Inverted function, press the *Down* key.
7. To access the Gyro Gain function, press the *Up* key.
8. To exit the Revolution Mixing function, press the *Down* and *Channel* keys simultaneously.



CHAPTER 6: FUNCTIONS (FUNCTION MODE) • Helicopter

6.13 GYRO GAIN FUNCTION

The X-378 offers two different types of Gyro Sensitivity Adjustments: manual or automatic. This feature gives the user the choice of selecting gyro sensitivity through the rudder dual rate switch(AUX-2) or

automatically through the flight mode switch. If you do not intend to use this function, leave this operation at the factory default position (off).

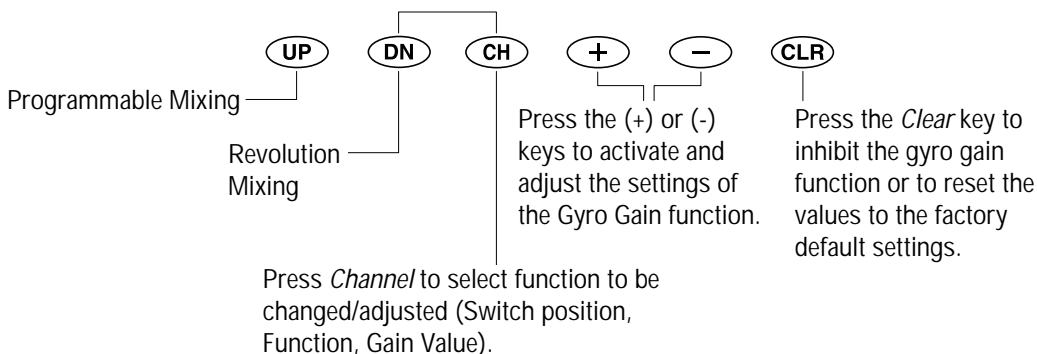
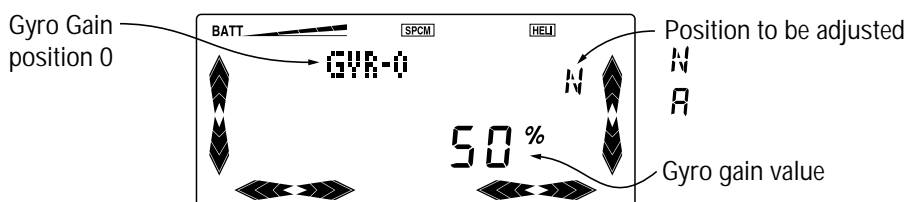

Accessing the Gyro Gain Function

1. Place the transmitter switch in the On position.
2. Press the *Down* and *Channel* keys simultaneously to enter the Function mode.
3. Press either the *Up* or *Down* key until "GYRO" appears at the center of the LCD.
4. Press the (+) or (-) keys to activate the Gyro Gain function. The name on the display will change from GYRO to a flashing "GYR-0."
5. Press the *Channel* key to select the function to be adjusted
6. Press the (+) or (-) keys to activate and adjust the settings of the Gyro Gain function.
7. To access the Revolution Mixing function, press the *Down* key.
8. To access the Programmable Mixing function, press the *Up* key.
7. To exit the Gyro Gain function, press the *Down* and *Channel* keys simultaneously.



CHAPTER 6: FUNCTIONS (FUNCTION MODE) • Helicopter

Manual Gyro Sensitivity Adjustment

Manual gyro sensitivity adjustment allows the pilot to select from two different gyro sensitivities during all flight conditions. This function is activated in conjunction with the rudder dual rate(AUX-2) switch.

- 1 Select the position for gyro sensitivity by pressing Channel key. "GYR-0" will be flashing. Select the Gyro Gain position 0 or 1 by pressing (+) or (-) key.
2. Select the type of sensitivity adjustments by pressing the Channel key once. The letter "N" or "A"

will now also be flashing at the upper right portion of the LCD. "N" is for manual (AUX 2 switch) and "A" for Automatic (Flight mode switch).

- 3 For manual operation, select the N by pressing (+) or (-) key.
- 4 Press the Channel key once again and you will see a right arrow flashing at the lower left portion of the LCD. This indicates that you can now adjust the gain value for the 0 AUX 2 switch position by using the (+) or (-)keys.

Manual Gyro Gain (Aux 2 Switch Activation) Positions

Switch Position for Gyro Sensitivity	Type of Sensitivity Adjustment
0 and 1	N for manual A for Automatic

Gyro Sensitivity Range 0 to 100%

1. To access the Revolution Mixing function, press the *Down* key.
2. To access the Programmable Mixing function, press the *Up* key.

3. To exit the Gyro Gain function, press the *Down* and *Channel* keys simultaneously.



CHAPTER 6: FUNCTIONS (FUNCTION MODE) • Helicopter

Automatic Gyro Sensitivity Adjustment

Automatic gyro sensitivity adjustment feature allows the pilot to automatically alter the sensitivity of the gyro from either of two pre-determined settings through the use of the flight mode switch. As different

flight modes are selected, the gyro's sensitivity rate will switch to the predetermined compensation rate for each particular flight mode in use.

Flight mode position to be adjusted

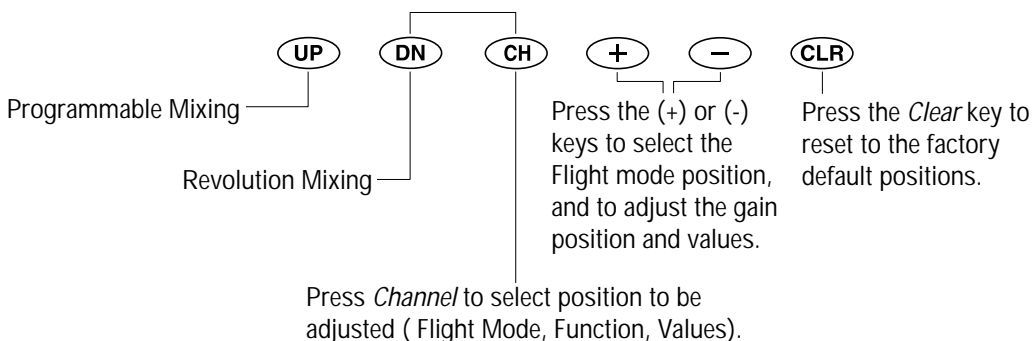
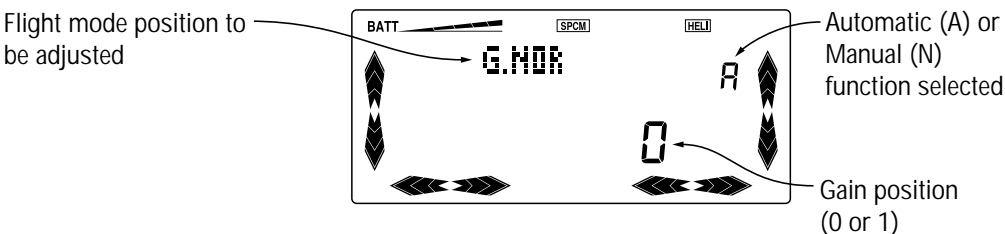

Activating the Automatic Gyro Gain Function

1 To activate the Automatic Gyro Gain function, press the *Channel* key once. The letter "N" or "A" will now also be flashing at the upper right portion of the LCD. "N" is for manual (Aux 2 switch) and "A" for Automatic (Flight mode switch).

2 For Automatic operation, select the "A" by pressing (+) or (-) key.

3 Press the *Channel* key once again and you will see a right arrow flashing at the lower left portion of the LCD. This indicates that you can now adjust the gain value for the 0 gain position by using the (+) or (-) keys.

4 To adjust the gain position 1, press the *Channel* key until the word "GYR-0" is flashing on the screen. Next, press the (+) or (-) keys and the screen will change to read "GYR-1." Press the *Channel* key twice

until there is a flashing right arrow at the bottom left of the screen. This indicates that you can now adjust the gain value for the 1 gain position by using the (+) or (-) keys.

5 To adjust the gain positions (0 or 1) for each flight mode, press the *Channel* key until "GYR-0" or "GYR-1" is flashing on the LCD. Next, press the (=) or (-) keys until the word "G.NOR" (normal mode) is displayed.

6 Next, press the *Channel* key twice until the flashing right arrow at the bottom left of the LCD is present.

7 Press the (+) or (-) keys to change the Gain position from the 0 to 1 position as needed.

Repeat Steps 5 through 7 above to select the gain positions (0 or 1) for each of the remaining flight modes.



CHAPTER 6: FUNCTIONS (FUNCTION MODE) • Helicopter

To Access the Automatic Gyro Gain Function

1. Place the transmitter switch in the On position.
2. Press the *Down* and *Channel* keys simultaneously to enter the Function Mode.
3. Press either the *Up* or *Down* key until "GYRO" appears at the center of the LCD.
4. Press the (+) or (-) keys to activate the Gyro Gain function. The name on the display will change from "GYRO" to a flashing "GYR-0."
5. Press the *Channel* key so that the 0 and N letters are flashing on the LCD screen.
6. Press the (+) or (-) keys. The "N" on the screen will change to "A," indicating that the Automatic Gyro Gain function has been selected.
7. To access the Revolution Mixing function, press the *Down* key.
8. To access the Programmable Mixing function, press the *Up* key.
9. To exit the Gyro Gain function, press the *Down* and *Channel* keys simultaneously.

Flight Modes

Recommended Gyro Gain positions

Normal (G.NOR)	0
Stunt (G.STN)	1
Hold (G.HLD)	1
Inverted(G.INV)	1

Gyro Remote Gain Connections: JR G460T and Other Remote Gain Gyros

Connect the white connector to from the G460T to the AUX2 channel of the receiver.



CHAPTER 6: FUNCTIONS (FUNCTION MODE) • Helicopter

6.14 PROGRAMMABLE MIXING 1-3

The X-378 offers three programmable mixes to be used for any number of different purposes. This function allows mixing any one channel to any other channel to make the aircraft easier to fly. This mix can be set in the computer and remain on at all times or switched on and off in flight using a number of different switches. Each channel of this radio is identified by a number. The chart below indicates the channel and its corresponding number. These numbers are used to establish the mixes. The number appearing first is known as the “master channel” or the channel to which you want to mix. The second number is known as the “slave channel” or the channel that is being mixed into the master. For example, 2-1 would indicate aileron-to-throttle mixing. Thus, each time the aileron stick is moved,

the throttle will increase or decrease based on the value of the input. Mixing is proportional, so small inputs of the master channel will produce small outputs of the slave channel.

Note that when using any programmable mix coupled to the throttle channel of the X-378, it will be necessary to increase the high throttle travel position of the channel to the maximum 150% to prevent over-traveling of the throttle by the addition of the programmable mix.

Each programmable mix has a mixing “offset.” The purpose of the mixing offset is to redefine the neutral position of the slave channel.

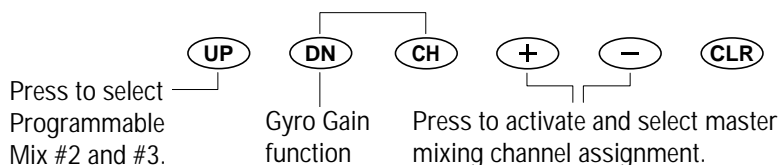
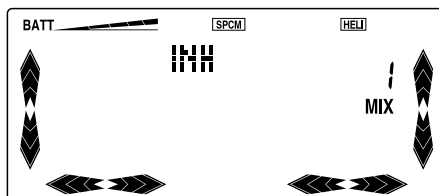

Accessing the Programmable Mixing Function

1. Place the transmitter switch in the On position.
2. Press the *Down* and *Channel* keys simultaneously to enter the Function mode.
3. Press either the *Up* or *Down* key until “MIX” and the number “1” appears at the upper right portion of the LCD.
4. Press the (+) or (-) keys to activate the mix.
5. Press the (+) or (-) keys to select the master channel.
6. Press the *Channel* key and then the (+) or (-) keys to select the slave channel.
7. Press the *Channel* key until a flashing arrow appears at the bottom right portion of the LCD. This left/right or up/down arrow indicates the current stick position of the master channel.
8. Move the master stick to the left/right or up/down position to be adjusted, and then use the (+) or (-) keys to assign the desired mixing values.



CHAPTER 6: FUNCTIONS (FUNCTION MODE) • Helicopter

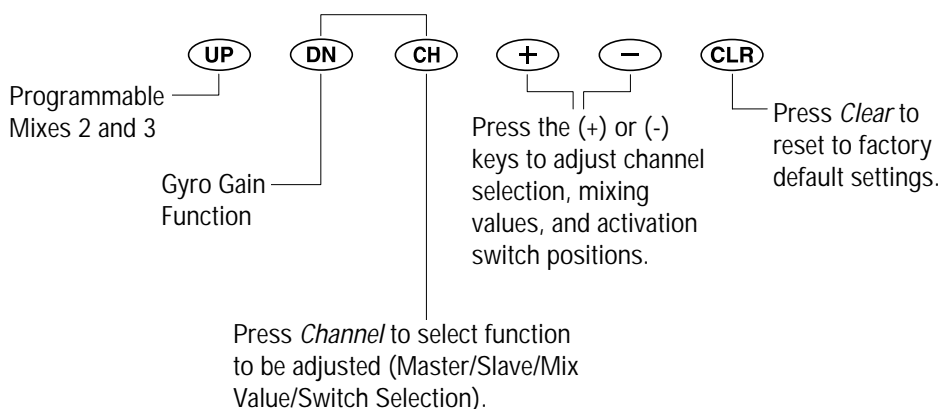
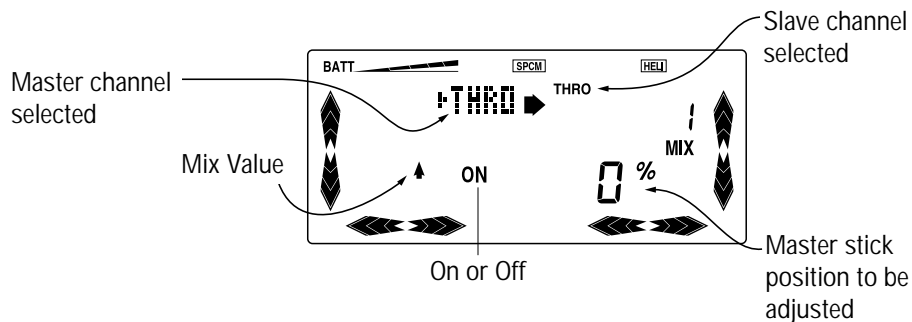

Assigning the Mix Activation

The programmable mixes can be turned on and off in flight using a variety of different switches. The chart below lists the indication seen on the LCD display and its definition. Pressing the (+) or (-) key will change the mixing On/Off switches.

Note: When the particular switch selected is in the Off position, the mixing value will indicate "Off."

CHAPTER 6: FUNCTIONS (FUNCTION MODE) • Helicopter

Selecting the Mix Activation Switch

1. Press the *Channel* key once. The letters "ON," as well as a smaller "SW" will appear at the center of the LCD.

2. Press the (+) or (-) keys to assign the mix activation to the options shown at right:

Program Mix #1

ON: Always on
 F-NR: Flight mode normal only
 (Activated by the flight mode switch)
 F-S12: Flight Modes 1 and 2 only
 (Activated by the flight mode switch)
 F-S2: Flight Mode 2 only
 (Activated by the flight mode switch)

Program Mix #2

ON: Always on
 Hold: Throttle Hold only
 (Activated by the Throttle Hold switch)
 F-S12: Flight Modes 1 and 2 only (Activated by the flight mode switch)
 GEAR: Activated by the Gear switch

Program Mix #3

ON: Always on
 Hold: Throttle Hold only
 (Activated by the Throttle Hold switch)
 F-S12: Flight Modes 1 and 2 only (Activated by the flight mode switch)
 GEAR: Activated by the Gear switch

Press the *Clear* key to reset to 0. Note: The master channel trim must be centered for this to reset to 0 using the *Clear* key.

10. Press the *Down* key to access the Gyro Gain function.

11. Press the *Up* key to access the Programmable Mix #2 and #3.

12. Press the *Down* and *Channel* keys simultaneously to exit the Programmable Mixing function.

Note: With a little practice, programmable mixing will be very easy compared to the first time you try it. Remember, the beauty of a computer radio is, if you don't like something, you can change it. Mixing is only limited by your imagination.



CHAPTER 6: FUNCTIONS (FUNCTION MODE) • Helicopter

Programmable Mixing Offsets

Any stick position of the master channel can be determined as the basic center point of mixing. The basic point is the position of the master channel stick, control switch, or knob where you set the mix value and the direction of mixing.

To set the basic point of mixing, hold the master channel in the desired position and press the *Clear* key. The display will indicate offset value from

neutral; however, mixing value at the determined position would indicate zero.

When properly adjusted, your heli should track across the sky at full speed with no correction needed. The X-378 has three programmable mixes that can free mix any two channels. Following are some examples of where this free mixing is used.

Pitch-to-Elevator Mixing

At full throttle, fast forward flight, most helicopters pitch either up or down. The X-378 has active digital trims in each flight mode to correct this. However, at intermediate speeds (e.g., 5/8 throttle) this pitching tendency is reduced.

Many top pilots use a combination of elevator stunt trim and Pitch-to-Elevator Mixing. Mix pitch (channel 6) to Elevator (channel 3) and select switch position 1, 2 so that the mixing is turned on in Flight mode 1 and 2. Then, hover your helicopter. Using forward cyclic only, push your heli into forward flight, but don't

change the pitch or throttle settings. After transitioning into forward flight, notice the direction the nose pitches. Correct this with stunt trim elevator until no pitching occurs at this throttle pitch setting.

Finally, fly your helicopter at full throttle/pitch in fast forward flight. If the nose pitches up, feed in down pitch to elevator mixing until straight flight is achieved. When properly adjusted, the heli will fly straight and level, hands off, at all throttle pitch settings.

Rudder-to-Throttle Mixing

During 540 stall turns and fast pirouettes, the tail rotor absorbs power and the main rotor rpm decays. This can be compensated for by mixing rudder-to-throttle so that when rudder is applied, the throttle is advanced. It usually takes about 15% right mixing and 10% left mixing.

Please note that when using any programmable mix coupled to the throttle channel of the X-378, it will be necessary to increase the high throttle travel position of the channel to the maximum 150% to prevent over-traveling of the throttle by the addition of the programmable mix.

Aileron-to-Throttle Mixing

When doing a roll or at anytime hard-over cyclic is used, the main rotor's rpm can decay due to increased loads. A way around this is to mix aileron to throttle so that when the aileron is displaced, throttle is added. Use about 10-30 % in both directions.

Please note that when using any programmable mix coupled to the throttle channel of the X-378, it will be necessary to increase the high throttle travel position of the channel to the maximum 150% to prevent over-traveling of the throttle by the addition of the programmable mix.



CHAPTER 6: FUNCTIONS (FUNCTION MODE) • Helicopter

6.15 PCM FAIL-SAFE/HOLD FUNCTION

The Fail-Safe/Hold function is available only when you use the XP-783 transmitter in either of the PCM modulations: S-PCM or Z-PCM. This function is designed to help minimize damage to your aircraft during a loss of signal to the receiver. The servos either assume the fail-safe presets or hold their last good signal position.

Note: In the PCM modulations, the Fail-Safe/Hold function cannot be totally disabled so that the servos will react to interference in the same way as they do in a PPM system. This is only possible with the use of a PPM receiver and the transmitter in the PPM modulation. Since the actual screen appearance varies depending on the modulation of your radio, refer to the appropriate modulation section which follows. As noted earlier, if you are in

the PPM modulation, the Fail-Safe/Hold function is not applicable. Therefore, the Fail-Safe/Hold function will not appear on your LCD in the PPM mode. Refer to the Modulation Selection section for more information pertaining to the broadcast signal of your XP-783 helicopter transmitter.

Accessing the Fail-Safe/Hold Function in Z-PCM Modulation Hold (Z-PCM) The Hold function is automatically activated when the radio is turned on and is in the Z-PCM modulation. This function stops (or holds) the servos in the positions they were in just prior to the interference. Therefore, your aircraft maintains the position held immediately before the interference was experienced. When a clear signal is restored, the Hold function releases and control of the airplane returns to you.

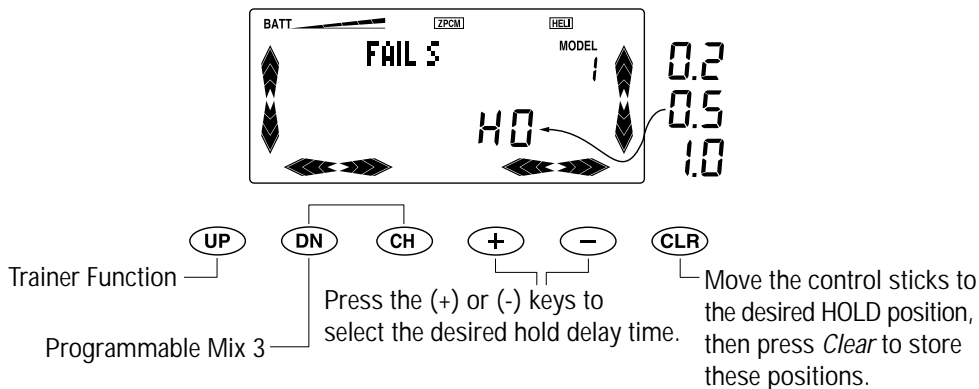

Accessing the PCM Hold Function (Z-PCM)

1. Place the transmitter power switch in the On (upper) position.
2. While the power switch is in the On position, press the *Up* and *Down* keys simultaneously to access the Function mode.
3. Press either the *Up* or *Down* key until "FAL.S" (Fail-Safe) appears in the left portion of your LCD.

Note: If "FAL.S" does not appear on your LCD, it is because you are transmitting in PPM. Fail-Safe is not applicable in the PPM mode. Refer to the Modulation Mode Selection section for more information. You should never attempt to adjust the Fail-Safe function when the aircraft is running.

When the Fail-Safe function is activated (i.e., when the signal is interrupted), the transmitter automatically moves each servo to a preset position. The position that each servo assumes is determined by you, as is the time length of interference that must occur before servo movement.

After the interference has ceased, control of the aircraft returns immediately to you. There are three time delays to choose from: 1/3 second, 1/2 second and 1.0 second. These time delays are the amount of time it takes, starting the moment the interference occurs, until the servos assume their preset positions.



CHAPTER 6: FUNCTIONS (FUNCTION MODE) • Helicopter

Setting the Fail-Safe/Hold Function in Z-PCM Modulation

1. After accessing the Fail-Safe function, adjust the Fail-Safe presets.
2. Select among the three time delays (.25, .50 or 1.0 second), by pressing (+) or (-) key until the appropriate delay appears on the screen.
3. Hold the transmitter sticks in the positions that you want the servos to assume during signal loss conditions. You can determine fail-safe preset positions for the other channels by placing the potentiometers and switches in the positions that you want them to assume during interference.
5. With the sticks, switches and potentiometers in the Fail-Safe positions, touch the *Clear* key. This will enter these locations as the fail-safe memory settings.
6. To confirm that the input of data was successful, switch the transmitter off. The controls will move to the input locations. If not, repeat Step 5 again.
7. To access the Programmable Mix 3 function, press the *Down* key.
8. To access the Trainer function, press the *Up* key.
9. To exit the Fail-Safe function, press the *Up* and *Down* keys simultaneously.

Note: These preset positions remain stored in the transmitter's memory until both the transmitter battery pack and the lithium back up battery have been removed (or until data reset has been performed). Therefore, you do not have to reset the Fail-Safe each time you fly. Should you want to re-adjust the Fail-Safe presets, access the Fail-Safe function and adjust the presets as you have just done. The transmitter automatically recalls the settings for the last Fail-Safe adjustment.

Accessing the Fail-Safe/Hold Function in S-PCM Modulation

The Hold function is automatically activated when the radio is turned on and is in the S-PCM modulation. This function stops (or holds) the servos in the positions they were in just prior to the interference.

Therefore, your aircraft maintains the position held immediately before the interference was experienced. When a clear signal is restored, the Hold function releases, and control of the aircraft returns to you.

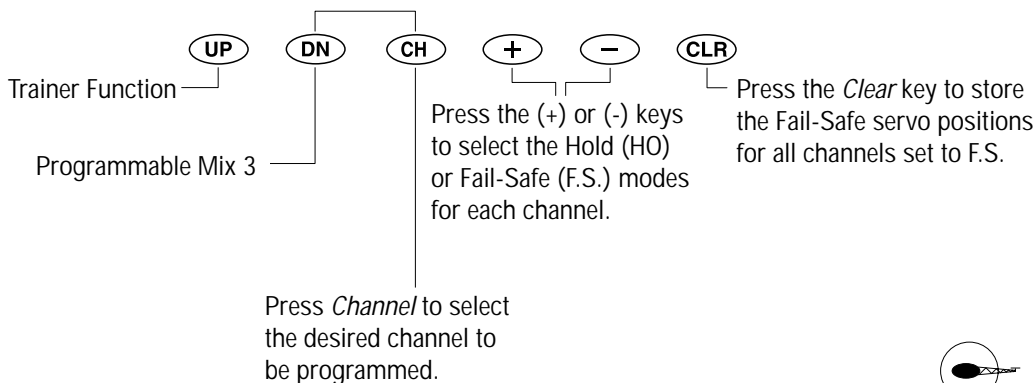
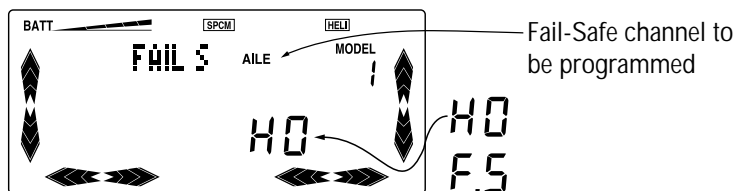

CHAPTER 6: FUNCTIONS (FUNCTION MODE) • Helicopter

Accessing the Fail-Safe/Hold Function in S-PCM Modulation

1. Place the transmitter power switch in the On (upper) position.
2. While the power switch is in the On position, press the *Up* and *Down* keys simultaneously to access the Function mode.
3. Press either the *Up* or *Down* key until "FAL.S" appears in the left portion of your LCD.

Note: If "FAL.S" does not appear on your LCD, it is because you are transmitting in PPM. Fail-Safe is not applicable in the PPM mode. Refer to the Modulation Mode Selection section for more information.

Fail-Safe/Hold Combination in S-PCM Modulation

The XP-783 allows you to combine the Hold and Fail-Safe presets for all seven channels on the receiver; you can select Fail-Safe or Hold independently for all channels on your aircraft. Some channels will hold their last clear signal position, while others assume the preset position. Once the Fail-Safe has been activated by signal interruption (interference), the transmitter automatically moves the servos to a preset position.

The predetermined servo positions are set by you. In the S-PCM Fail-Safe, the time delay (the amount of time it takes, starting the moment the interference occurs, until the servos assume the preset positions) is fixed at .25 seconds. After the interference has ceased, normal operation of the aircraft returns to you immediately.

Setting Fail-Safe/Hold Combination in S-PCM Modulation

1. After accessing the Fail-Safe function, it is time to adjust the fail-safe presets.
2. Select all of the channels for which you want to enter a fail-safe preset. To do so, use the *Channel* key until the appropriate channel number appears on the LCD. We will use only channel 2 (aileron) for our example. The display will appear as follows:
3. Press either the (+) or (-) key. This will change the display from hold to the Fail-Safe preset display.

Note: Your LCD may display a number on the right side. This number is the previous fail-safe preset of the stick, switch, and potentiometer position of your transmitter at last fail-safe memorization. The display will appear as follows:

4. Next, press the *Up* key one time. Once again your display will change. It will appear as:
5. Hold the appropriate transmitter control stick (potentiometer or switch) in the desired location and press the *Clear* key. This will enter the location as the fail-safe memory setting for the relative channel. Continuing our example, hold the aileron stick to the right and press the *Clear* key.
6. Press the *Down* key. Your Fail-Safe preset value will be displayed on the LCD.

Note: Values will change between transmitters. In our example, the screen would appear as follows:

7. To confirm that the input of data was successful to the applicable channels, switch the transmitter off. The respective channels will move to the input locations.
8. To access the Mixing B function, press the *Down* key.
9. To access the Trainer function, press the *Up* key.
10. To exit the Fail-Safe/Hold function, press the *Up* and *Down* keys simultaneously.

Note: These preset positions remain stored in the transmitter's memory until both the transmitter battery pack and the lithium backup battery have been removed (or until the Data Reset function has been utilized). Therefore, you do not have to reset the Fail-Safe each time you fly. Should you want to re-adjust the Fail-Safe preset position, access the Fail-Safe function once again and adjust the presets as you have just done. The transmitter automatically recalls the settings for the latest Fail-Safe adjustment.



CHAPTER 6: FUNCTIONS (FUNCTION MODE) • Helicopter

6.16 TRAINER SYSTEM

The X-378 transmitter employs two separate types of trainer systems:

1. Normal Trainer System - All functions are controlled by either the master transmitter or the slave transmitter

2. Programmable Function Trainer Stick functions may be assigned to the slave one at a time. Since the control functions can be transferred one at a time, students can concentrate on only one function at a time until they are competent to fly solo.

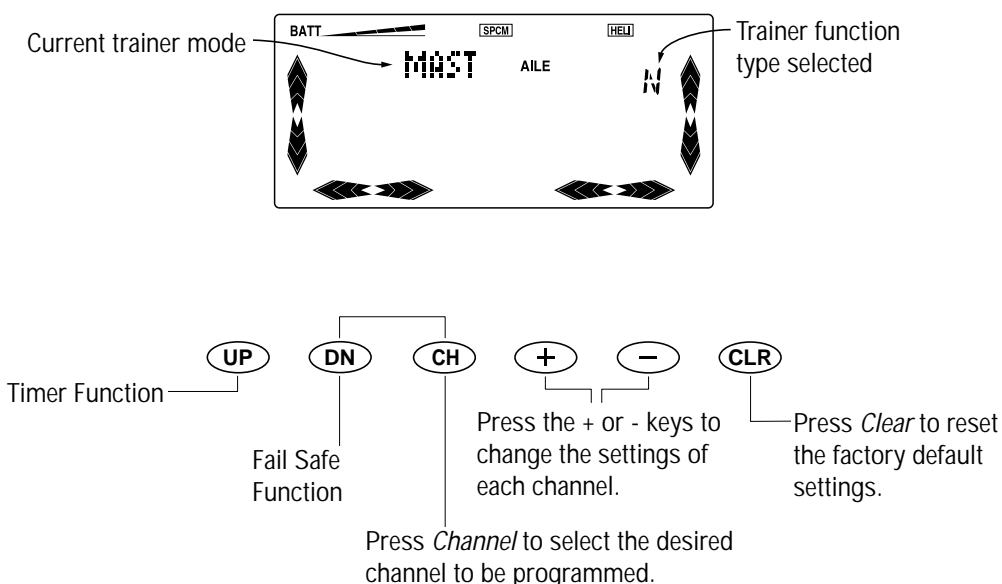

Accessing the Programmable Trainer Function

1. Move the transmitter switch to the On (Upper) position.
2. Press the *Up* and *Down* keys simultaneously to enter the Function mode.
3. Press the *Up* or *Down* key until "TRN." appears on the left portion of the LCD.
4. Press the *Channel* key to select the channel indicated just to the right of the TRN.
5. Once the channel appears that you want to make a slave, press the (+) or (-) key. This will change the display from "NORM" to "SLAV." If you want to make more slave channels, press the *Channel* key until the next desired channel is shown and press the (+) or (-) key.
6. To change the Programmable Trainer function back to normal system, press the *Clear* key.
7. To access the Fail-Safe function, press the *Down* key.
8. To access the Timer function, press the *Up* key.
9. To exit the Trainer function, press the *Up* and *Down* keys simultaneously.

CHAPTER 6: FUNCTIONS (FUNCTION MODE) • Helicopter

Basic Connections and Conditions for Training

1. The slave transmitter must be PPM (Pulse Position Modulation) with a DSC (Direct Servo Control) jack. If the slave transmitter is PPM/PCM selectable, select PPM. The master transmitter can be PCM or PPM.
2. Plug the trainer cord (optional part #JRPA130) into each transmitter's DSC jack.

Note: Each transmitter will appear to be on, but neither is actually transmitting at this time.

3. Switch the master transmitter on. Do not switch on the slave transmitter; it is only necessary to have the master transmitter on.

Note: If the master transmitter is the XP-783, its LCD will indicate "TRN.M" (Trainer Master) when the power switch is on.

4. Pull the trainer switch toward you to transfer control to the slave. Releasing the switch automatically reverts to the master transmitter.
5. Be sure the slave transmitter's servo reversing, dual rates, end-point adjustment and trims are identical to the master transmitter. This can be checked by pulling the trainer switch toward you. If the control surfaces move, adjust the slave transmitter until the trainer switch can be activated without a change of the control surface position.

Use of the Normal Trainer System

In this mode, all functions are switched from the master to the slave using the trainer switch. This is the Normal mode; no function setup is necessary to activate this system.

Use of the Programmable Trainer Function (PTF)

In this mode, the master may assign functions to the student one at a time to make learning to fly easier.

The master may assign the slave rudder and elevator. Then, when the trainer switch is activated (pulled forward), the slave has control of rudder and elevator only while the master retains control of throttle and aileron.

Note: When all channels are set to master, the Trainer System becomes Normal.



CHAPTER 6: FUNCTIONS (FUNCTION MODE) • Helicopter

6.17 TIMER FUNCTION

The X-378 offers two separate types of Timer functions: Countdown and Stopwatch. The Countdown Timer time is input in 10 second intervals up to 35 minutes. The timer can be set for each individual model and retained in memory. In order for the Timer function to be activated, it must be in the Normal display. From the Normal display, pressing the *Channel* key will change the left side of the LCD from the model name to the Timer function. The timer is now started and stopped by pressing either the (+) or (-) key. It can also be started and stopped using the snap roll/trainer switch at the left-rear portion of the transmitter. When the X-378 is being used as the master transmitter in the Training

function the trainer switch will not operate the timer start/stop function.

Note: In the Countdown mode, the transmitter will beep three times: 30 seconds, two times at 20 seconds, and beep one time every second from :10 to 0. At zero there will be a continuous tone for 1 second and then the timer will begin counting up with a (+) indication to the left of the time value. When used as the stop-watch, the timer will count up to 44 minutes 59 seconds, at which time it will reset to zero and continue to count.

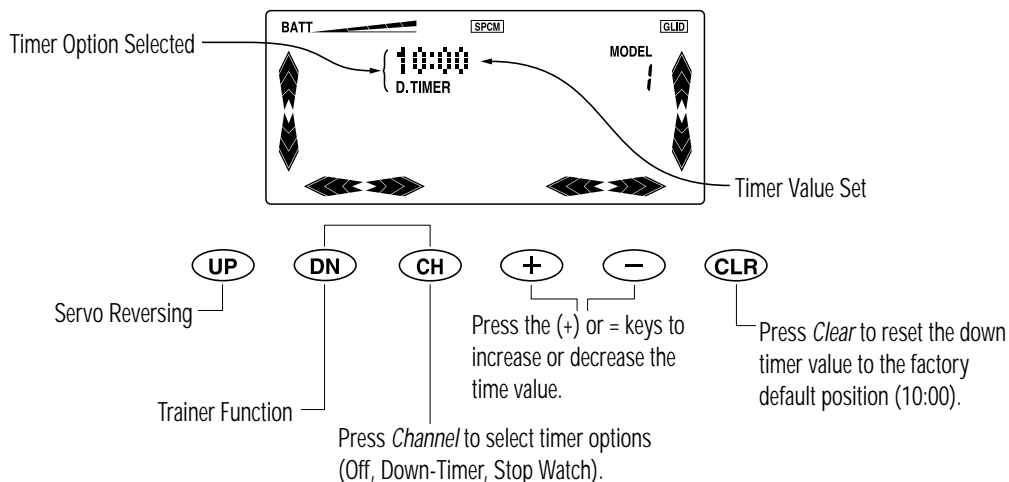

Accessing the Timer Function

1. Place the transmitter switch in the On position.
2. Press the Up and Down keys simultaneously to enter the Function Mode.
3. Press either the Up or Down key until "TIMR" is displayed in the left portion of the LCD.
4. The "STP.W" in the right portion of the display indicates the timer is in the Stopwatch (count-up) mode.
5. Pressing the (+) key will change the display to :10 each time the (+) is pressed, and the value will increase in 10 second intervals Up to 35:00 minutes. This is the Countdown Timer value. Pressing the *Clear* key will reset the Countdown Timer to the Stopwatch mode.
6. To access the Trainer function, press the *Down* key.
7. To access the Integral Timer function, press the *Up* key.
8. To exit the Timer function, press the Up and Down keys simultaneously.

Note: The Countdown Timer and Stopwatch can not operate simultaneously; If the Countdown Timer is set, the stopwatch is inhibited; if the Countdown Timer is inhibited, the stopwatch is defaulted to. The function of the Integral Timer is to keep track of the accumulated time in use. The Integral Timer counts up to 100 hours in one-minute increments. It is best to reset this timer each time the transmitter is recharged. The timer will then indicate the time of use on that particular charge.

CHAPTER 6: FUNCTIONS (FUNCTION MODE) • Helicopter

Accessing the Integral Timer Function

1. Place the transmitter switch in the On position.
2. Press the *Up* and *Down* keys simultaneously to enter the Function mode.
3. Press either the *Up* or *Down* key until "INT.T" is displayed in the left portion of the LCD.
4. The accumulated time of use will be displayed in the right portion of the LCD. To reset, press the *Clear* key. Note that the colon (:) flashes at a frequency of once per second.
5. To access the Timer function, press the *Down* key.
6. To access the Dual-Rate function, press the *Up* key.
7. To exit the Integral Timer function, press the *Up* and *Down* keys simultaneously.



SECTION IV • CHAPTER 1: SOFTWARE FUNCTIONS • Sailplane

1.1 CONTROL IDENTIFICATION AND LOCATION

Sailplane Version Transmitter

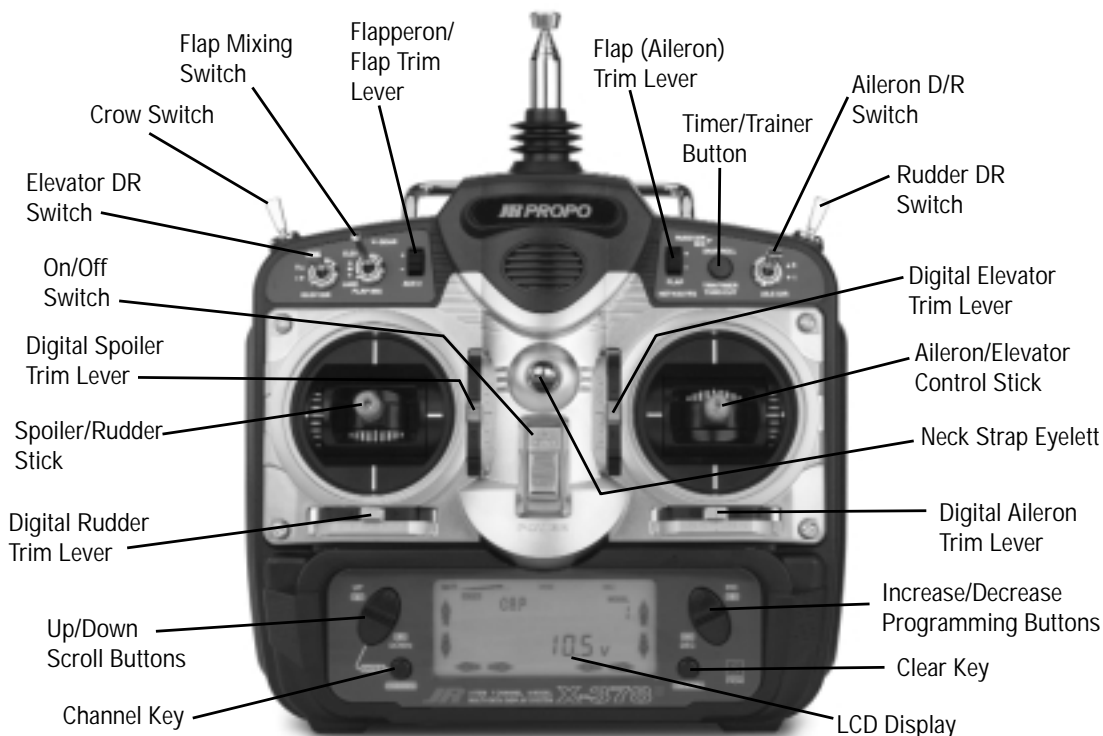

1.2 RECEIVER CHANNEL ASSIGNMENT/THROTTLE ALT

- | | | |
|----|-------|---|
| 1. | THRO | Spoiler Channel |
| 2. | AILE | Left Aileron Channel |
| 3. | ELEV | Elevator Channel |
| 4. | RUDD | Rudder Channel |
| 5. | GEAR | Gear Channel (right aileron channel—AILE 2) |
| 6. | AUX 1 | Auxiliary 1 Channel (left flap channel for dual flaps) |
| 7. | AUX 2 | Auxiliary 2 Channel (right flap channel for dual flaps) |

Throttle ALT

This function makes the throttle stick trim active only when the throttle stick is at less than half throttle,

which allows for fine adjustment of the spoilers with the throttle stick in the lower position.



CHAPTER 1: SOFTWARE FUNCTIONS • Sailplane

Helicopter Version Transmitter—Airplane Mode

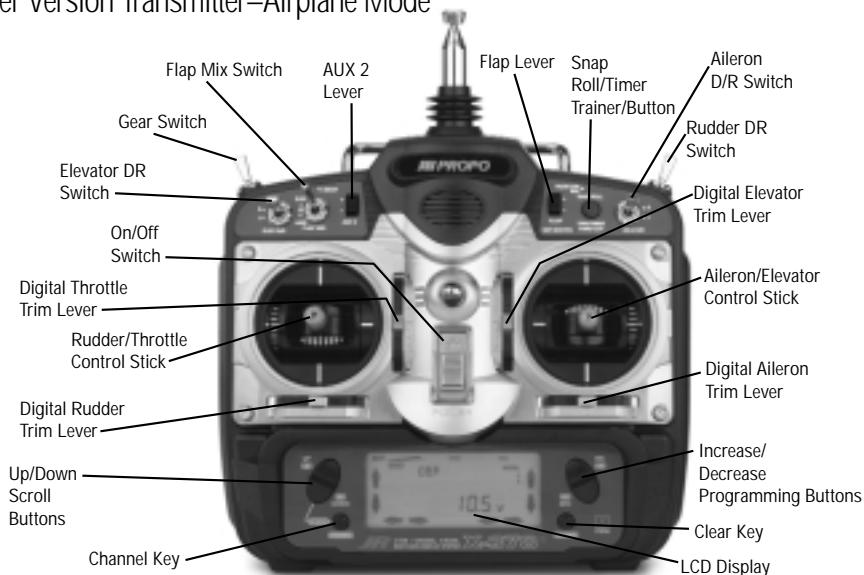

CHANNEL ASSIGNMENT

1.	THRO	Throttle Channel	5.	GEAR	Gear Channel
2.	AILE	Aileron Channel	6.	AUX 1	Auxiliary 1 Channel (Flap)
3.	ELEV	Elevator Channel	7.	AUX 2	Auxiliary 2 Channel (Spoiler)
4.	RUDD	Rudder Channel			

Helicopter Version Transmitter—Heli Mode

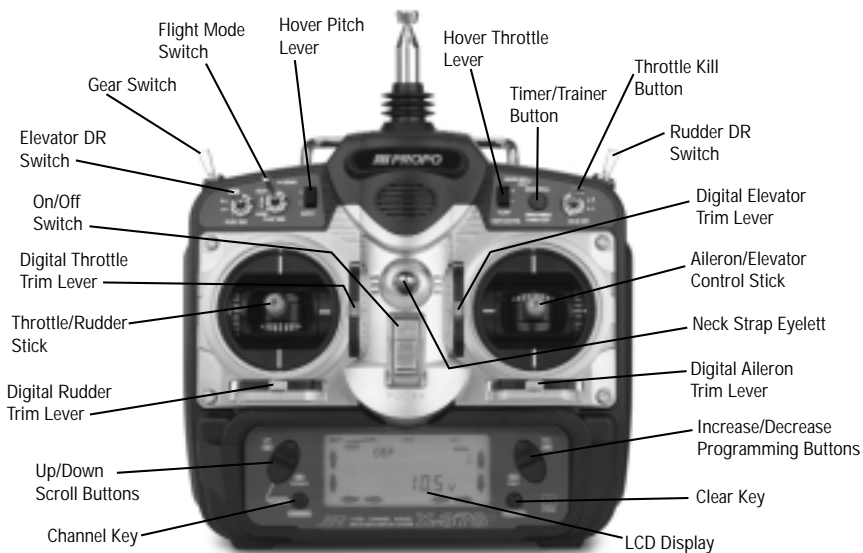

CHANNEL ASSIGNMENT

1.	THRO	Throttle Channel	5.	GEAR	Gear Channel
2.	AILE	Aileron Channel	6.	AUX 1	Auxiliary 1 Channel (Pitch)
3.	ELEV	Elevator Channel	7.	AUX 2	Auxiliary 2 Channel (Gyro Sensitivity)
4.	RUDD	Rudder Channel			



CHAPTER 1: SOFTWARE FUNCTIONS • Sailplane

1.3 TRANSMITTER REAR

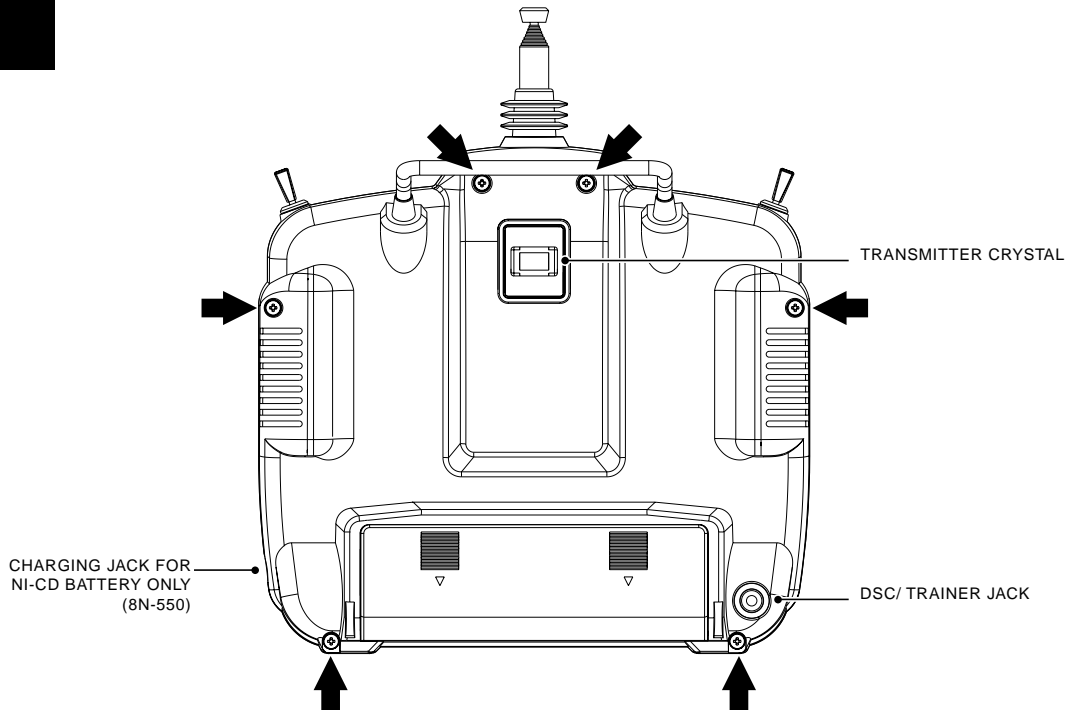

Transmitter Crystal Replacement Notice
 The Federal Communications Commission (FCC) requires that changes in transmitter frequency must be performed only by an authorized service technician (Horizon Service Center). Any transmitter frequency change made by non-certified technician may result in a violation of the FCC rules.

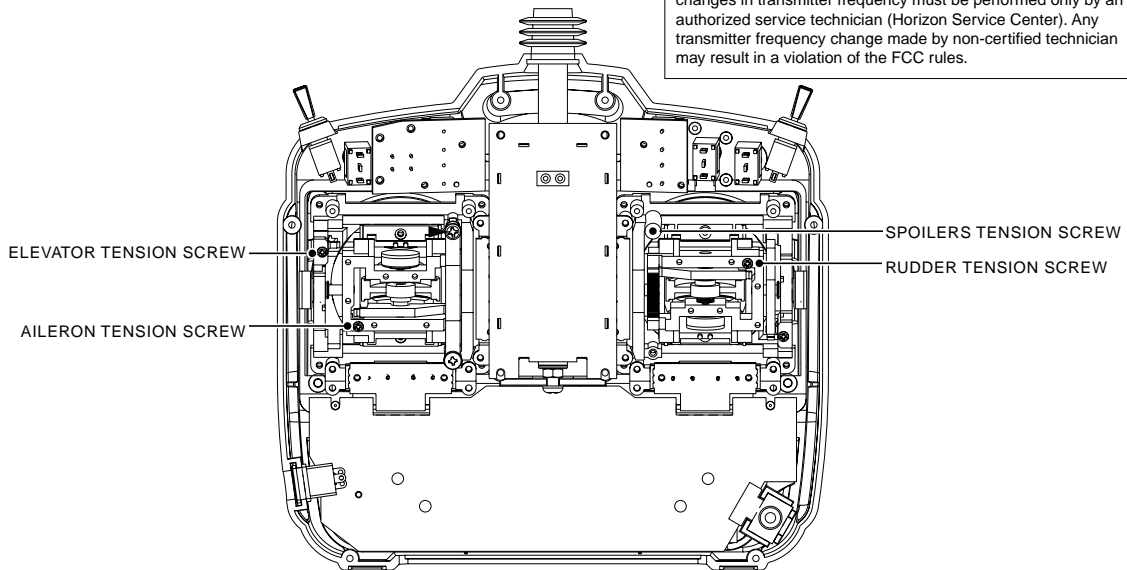

CHAPTER 1: SOFTWARE FUNCTIONS • Sailplane

1.4 CONTROL STICK LENGTH ADJUSTMENT

To adjust the stick length, use the 2mm Allen wrench (supplied with your X-378 transmitter) to unlock the set screw.

Note: Turn the wrench counterclockwise to loosen the screw. Then, turn the stick clockwise to shorten or counterclockwise to lengthen.

After the control stick length has been adjusted to suit your flying style, tighten the 2mm set screw. If you desire longer sticks, JR offers a thicker stick

(JRPA047) that is approximately one inch longer than the standard stick. This stick, crafted from bar stock aluminum, is available at your local JR dealer.

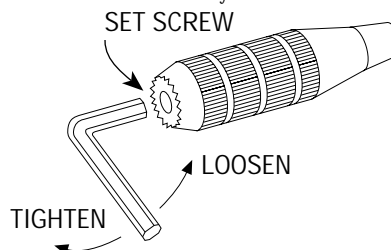

1.5 CONTROL STICK TENSION ADJUSTMENT

Remove the Ni-Cd battery and six transmitter back screws as shown on previous page). Pull the transmitter crystal and then remove the transmitter back, being careful not to cause damage to any of the components.

Adjust each screw for desired tension (counterclockwise to loosen stick feel, clockwise to tighten stick feel). When adjusting the throttle ratchet tension, make sure that the adjusting screw does not touch the PC board after adjustment is complete.

1.6 DIRECT SERVO CONTROL (DSC)

For proper DSC hook-up and operation:

1. Leave the transmitter power switch in the Off position. The transmitter will not transmit any radio frequency (RF) in this position.
2. Plug the DSC cord (supplied) into the DSC port in the rear of the transmitter.
3. The encoder section of the transmitter will now be operational, and the LCD display will be lit.
4. Plug the other end of the DSC cord into the receiver charge receptacle. Turn the switch harness to the On position. When you install the charging jack, be sure to hook the charging jack receptacle securely into the switch harness charge cord.

Why you should use the DSC function:

1. The DSC enables you to check the control surfaces of your aircraft without drawing the fully operational 200mAh from your transmitter battery pack. Instead, you will only draw 70mAh when using the DSC function.

2. The DSC function allows you to make final adjustments to your airplane without transmitting any radio signals. Therefore, if another pilot is flying on your frequency, you can still adjust your aircraft and not interfere with the other pilot's aircraft.

Note: Under no circumstances should you attempt to fly your aircraft with the DSC cord plugged in! This function is for bench-checking your airplane only.

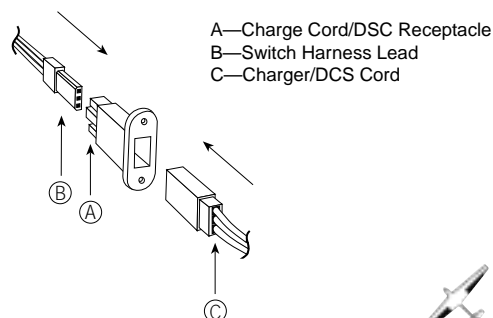

CHAPTER 1: CONNECTIONS • Sailplane

1.7 NECK STRAP ATTACHMENT

An eyelet is provided on the face of the X-378 transmitter that allows you to connect a Neck Strap (JRPA023). This hook has been positioned so that your transmitter has the best possible balance when you use the neck strap.

Note: Double-check to ensure that the neck strap is securely fastened to the transmitter.

1.8 BASE LOADED ANTENNA

An optional Base-Loaded Antenna is available for use with the X-378 transmitter. It is considerably shorter than the standard antenna. However, the base loaded antenna cannot be collapsed for storage inside the transmitter. You must also use an adaptor

(JRPA156) to attach the antenna to your X-378. The Base Loaded Antenna (JRPA155) is made of a flexible coil and is covered with a soft plastic material. Your range will not be affected when using the base loaded antenna.

1.9 FREQUENCY NOTES/AIRCRAFT ONLY FREQUENCIES

The X-378 transmitter employs a plug-in crystal for transmitter that is glued in place at the time of shipment. Per FCC regulation, the transmitter crystal should only be changed by a certified technician. Changing of the transmitter crystal by a non authorized technician could result in a violation of FCC rules.

The X-378 can transmit in either Pulse Code Modulation (PCM) or Pulse Position Modulation (PPM, commonly referred to as FM).

Be certain to observe the following guidelines:

1. Do not operate your transmitter when another transmitter is using the same frequency, regardless of whether the second transmitter is PCM, PPM (FM) or AM. You can never operate two transmitters on the same frequency simultaneously without causing interference to both receivers and crashing both aircraft.

2. For operation of your X-378 with additional receivers, you should refer to the receiver compatibility chart. The chart is located in the Modulation Selection Section of this manual.

Aircraft-Only Frequencies

JR RF modules and receivers are available in 72MHz frequencies in the United States for use with model aircraft. Employing 72MHz frequencies does not require a special operator's license from the Federal Communications Commission (FCC).

* A chart for all available frequencies is located on page 185 of this manual.



CHAPTER 2: CONNECTIONS • Sailplane

2.1 INSTALLATION REQUIREMENTS

It is extremely important that your radio system be correctly installed in your model. Here are a few suggestions on the installation of your JR equipment:

1. Wrap the receiver in protective foam rubber that is no less than 3/8 inch thick. Secure the foam to the receiver with #64 rubber bands. This protects the receiver in the event of a crash or a very hard landing.
2. The servos should be mounted using rubber grommets and brass bushings to isolate them from vibration. Do not over-tighten the mounting screws; this will negate the vibration absorption effect of the rubber grommets. The diagram on the right will assist properly mounting your servo.



3. The servos must be able to move freely over their entire range of travel. Make sure that the control linkages do not bind or impede the movement of any of the servos.
4. Mount all switches away from the engine exhaust and away from any high vibration areas. Make sure the switch operates freely and is able to operate over its full travel.
5. Mount the receiver antenna firmly to the airplane to ensure that it will not become entangled in the propeller or control surfaces.

2.2 CONNECTIONS

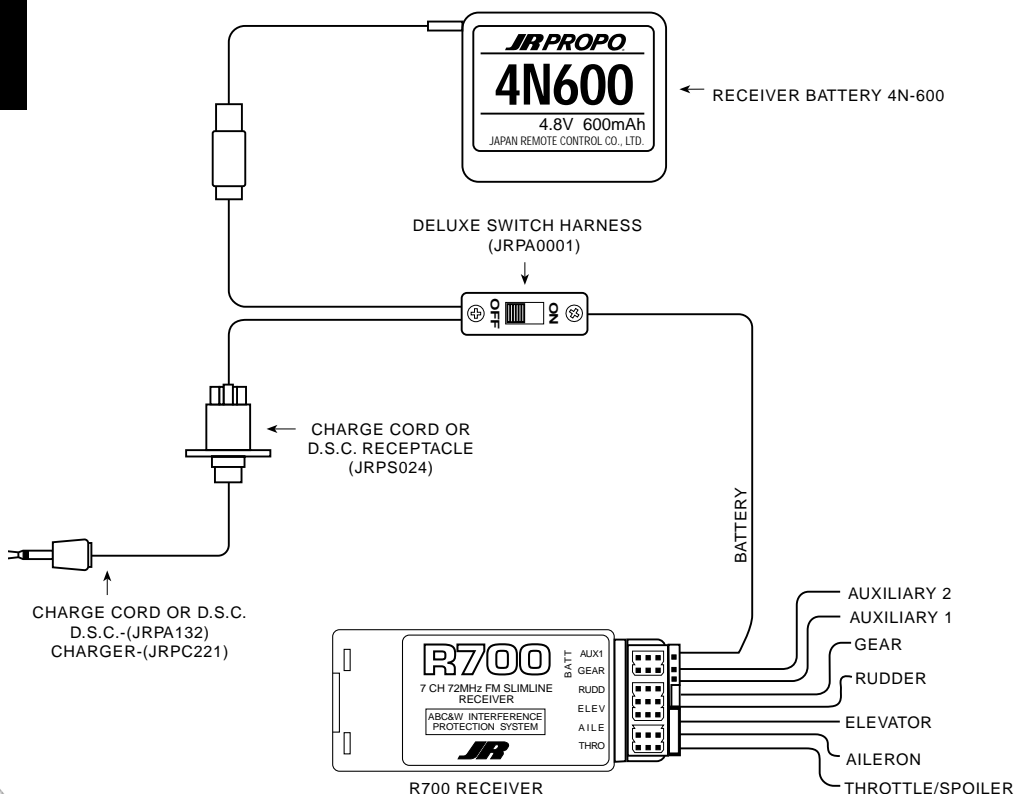

CHAPTER 3: INPUT MODE AND FUNCTION • Sailplane

3

KEY INPUT AND DISPLAY

The *Function Selection* keys are used to move up and down through the functions. The *Channel* key is used to advance the channel or function selected. The

Increase and *Decrease* keys are used to make changes in the selected functions.

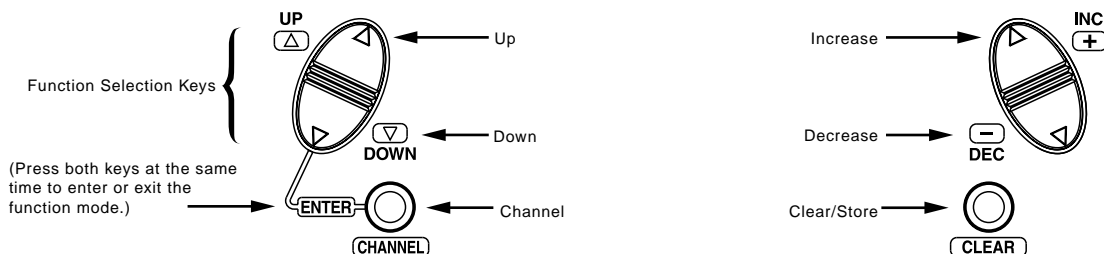

Hereafter, explanation of all functions in this manual will use the following designations to indicate pressing individual keys:



CHAPTER 4: ALARM AND ERROR DISPLAY • Sailplane

4.1

BATTERY ALARM AND DISPLAY

When the transmitter voltage drops below 9.0-volts DC, the display flashes "BATT" and an alarm sounds

seven times. If you are flying when this occurs, land immediately.

4.2

BACK-UP ERROR DISPLAY

All preprogrammed data is protected by a five-year lithium battery that guards against main transmitter battery failure. Should the lithium battery fail, the display will indicate ERR1 regardless of the position of the On/Off switch. If this occurs, it will be necessary to replace the battery and reprogram all data. All transmitter programs will return to the factory default settings, and the data you have input will be lost. When it becomes necessary to replace the lithium back-up battery, contact JR Horizon Service Center. Due to the possibility of extensive

damage caused by improper removal or replacement, only JR Horizon Service Center is authorized to make this change.



CHAPTER 5: INPUT MODE AND FUNCTION • Sailplane

5.1 NORMAL DISPLAY

When the power switch is in the On position, the display will read as follows:

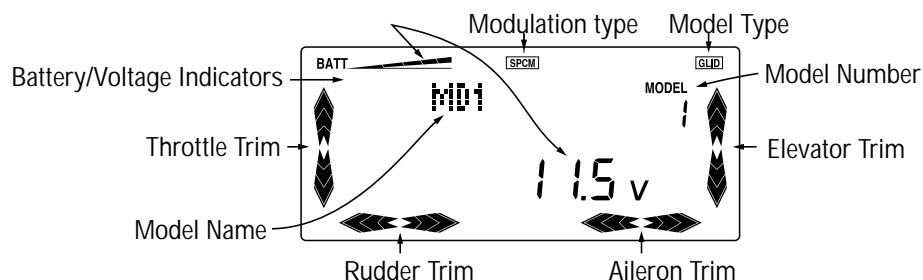

To enter the System mode, press simultaneously then turn on the power switch. To enter the Function model, turn on the power switch, then press simultaneously.

UP

DN

CH

+

-

CLR

In the Timer mode, press the *Channel* key to Start/Stop the timer.

Press the *Clear* key to reset the timer.

5.2 DIRECT ACCESS DIGITAL TRIMS

The X-378 is equipped with a Direct Access Digital Trim Value function. When at the normal display, if a digital trim lever is moved, the screen will automatically change to show the current trim value for the channel being adjusted. When the trim is returned to center, the screen will change back to the normal display screen after a few seconds.

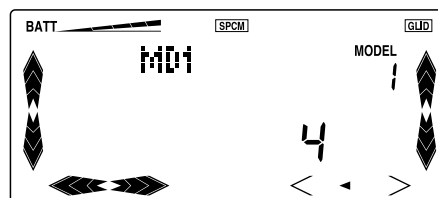

Displays the current trim value for the channel being adjusted

CHAPTER 5: INPUT MODE AND FUNCTION • Sailplane

5.3 SYSTEM MODE

To enter the System mode, press the *Down* and *Channel* keys simultaneously, then turn the power switch to the on position. The display will show the last active program. Pressing either the *Up* or *Down* key then scrolls through the functions one by one, according to the System Mode flowchart shown at the right. Once the appropriate function is displayed, changes can be made by pressing the (+) or (-) keys.

System Mode Flowchart

Information pertaining to each function is explained on the page listed next to the function name. Functions will appear in the same order they are shown on this chart.

Accessing the System Mode

1. Press the *Down* and *Channel* keys simultaneously.
2. Move the power switch to the On (upper) position.
3. Use either the *Up* or *Down* to scroll through the menu and access the applicable function.

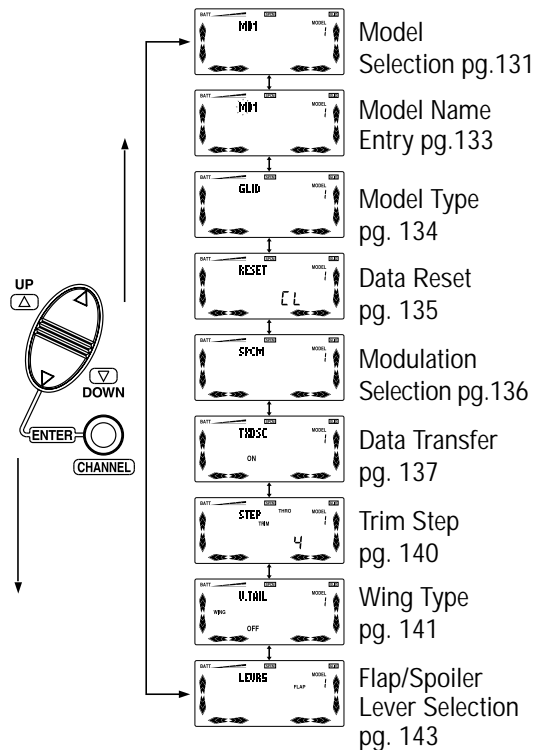

CHAPTER 5: INPUT MODE AND FUNCTION • Sailplane

5.4 MODEL SELECTION/MODEL COPY SELECT

The X-378 system offers memory for eight completely separate models. Therefore, it is possible to have a mixture of helicopter, airplane and sailplane setups retained in memory. It is also recommended that the Model Name Entry function be used in conjunction

with each model setup. Another very useful function of the Model Selection function is the ability to set one aircraft up several different ways. This is helpful when multi-task performance is desired.

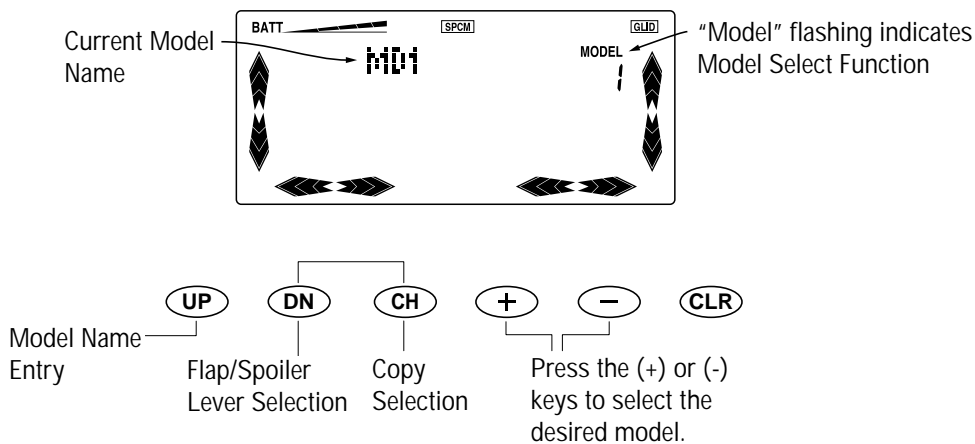

Accessing the Model Selection Function

1. While pressing the *Down* and *Channel* keys, switch the transmitter to the On position to enter the System mode.
2. Model should be flashing on the right top portion of the LCD. If not, press the *Up* or *Down* key until "Model" is displayed and flashing.
3. Pressing the (+) or (-) key will select among each of the eight models available. Notice that as each model is selected, its name appears in the left portion of the LCD.
4. To access the Copy Selection function, press the *Channel* key.
5. To access the Model Name Entry function, press the *Up* key.
6. Once the desired model is displayed on the left, pressing the *Down* and *Channel* keys simultaneously will exit the Model Selection function and establish the model displayed as the new current model.

Note: When changing from one model type to another, it is not necessary to use the Type Selection function. This is done automatically by the computer.

CHAPTER 5: INPUT MODE AND FUNCTION • Sailplane

Model Copy Select

The Copy Selection function enables you to copy all of the settings of the current model to another model within the same transmitter. This is very

useful when setting up one aircraft several different ways or when trying an alternative set up of your current model.

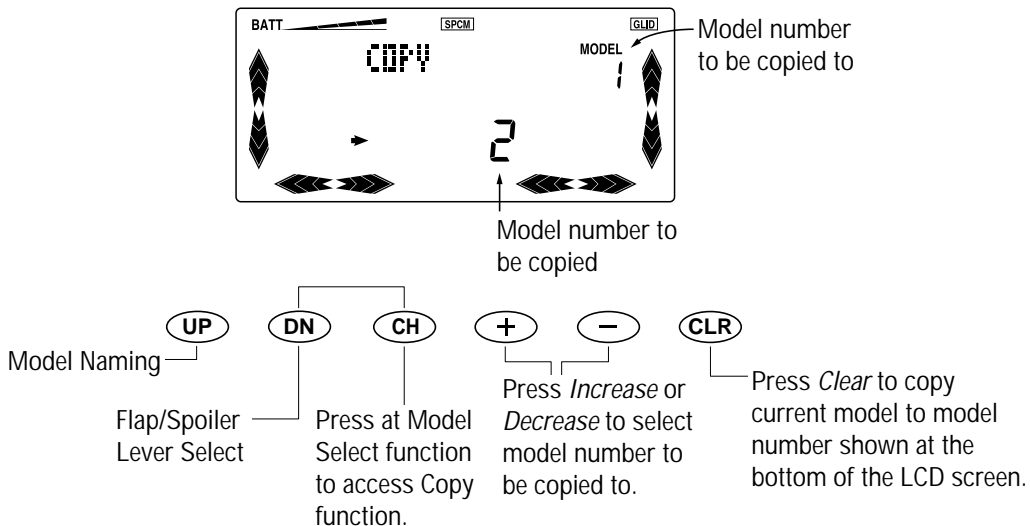

Accessing the Copy Selection Function

1. While pressing the *Down* and *Channel* keys, move the transmitter's power switch to the *On* position.
2. Press either the *Up* or *Down* key until "Model" appears flashing on the top right side of the LCD.
3. The number that appears below the flashing "Model" is the current model. This is important to note as only the current model will be the copied or "from" model. It is imperative to retrieve the proper current model prior to initiating the copy sequence. Press the *Increase* or *Decrease* keys to select the desired model to be copied.
4. Press the *Channel* key once. The word "Copy" will appear at the top left of the screen indicating that the Copy function has been selected.
5. The large number (1–8) at the bottom center of the LCD indicate the accepting model.
6. Press the *Increase* or *Decrease* keys to select the accepting model number.

Note: Always make sure that the accepting model is either free of input or one that you

no longer want to retain in your transmitter's memory. Once the copying process has been completed, the information of the accepting model is lost and the current model is input as the new data.

7. Once the desired accepting model is selected, press the *Clear* key to complete the Copy Selection function. The model number at the bottom of the screen will flash several times indicating that the model copy function was successful. The "from" or template model's name and data will now replace that of the accepting model.
8. To access the Flap/Spoiler Lever Select function, press the *Down* key.
9. To access the Model Naming function, press the *Up* key.
10. To exit the Copy Selection function, press the *Down* and *Channel* keys simultaneously.



CHAPTER 5: INPUT MODE AND FUNCTION • Sailplane

5.5 MODEL NAME ENTRY

The X-378 allows a 3-digit name to be input for each of the eight models available. The current model will be displayed in the Normal display when the timer is

not active. You may also find this useful to identify different aircraft setups.

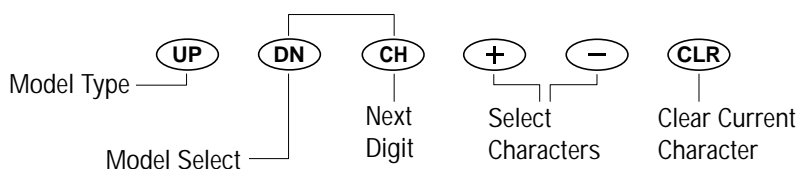
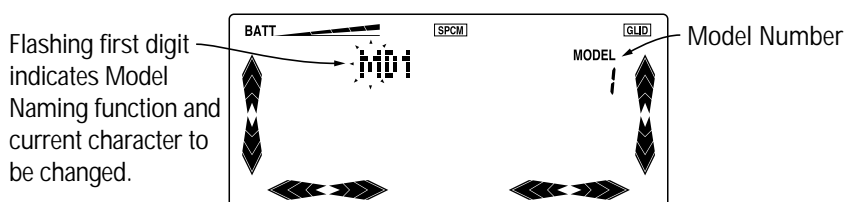

Accessing the Model Name Entry Function

1. While pressing the *Down* and *Channel* keys, switch the transmitter to the On (upper) position to enter the Model Setup mode.
2. Use the Model Selection function to select the model you want to name. (Please refer to the Model Selection section at this time.)
3. Press either the *Up* or *Down* key until the first digit of the model to be named is flashing on the left portion of the LCD.
4. The current name will be displayed in the left portion of the LCD. Pressing the (+) or (-) key will select the first alphanumeric character.

Note: The character being selected will flash.

5. Press the *Channel* key to advance the character selection to the next character.
6. Repeat this procedure until all three characters are selected.
7. To access the Model Selection function, press the *Down* key.
8. To access the Type Selection function, press the *Up* key.
9. To exit the Model Name Entry function, press the *Down* and *Channel* keys simultaneously.

CHAPTER 5: INPUT MODE AND FUNCTION • Sailplane

5.6 MODEL TYPE SELECTION

The X-378 is capable of performing as a helicopter, airplane or sailplane radio with full functions for each.

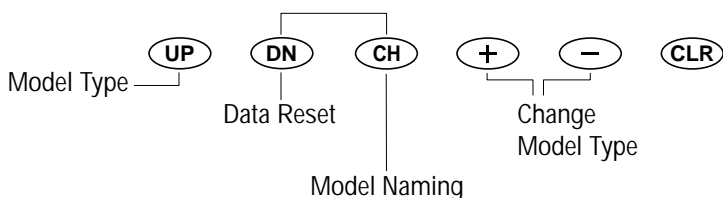
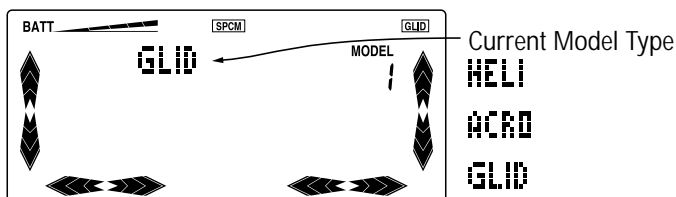

Accessing the Type Selection Function

1. While pressing the *Down* and *Channel* keys, switch the transmitter to the On position to enter the Model Setup mode.
2. Press either the *Up* or *Down* keys until "Acro," "Heli," or "Glid" is displayed in the left portion of the LCD.
3. Pressing either the (+) or (-) key will change the type of model.
4. To access the Model Name Entry function, press the *Down* key.
5. To access the Data Reset function, press the *Up* key.
6. To exit the Type Selection function, press the *Down* and *Channel* keys simultaneously.



CHAPTER 5: INPUT MODE AND FUNCTION • Sailplane

5.7 DATA RESET

The Data Reset function permits you to reset all the functions and settings for the current model to factory conditions. Resetting does not affect the data already programmed for other models. Be sure to

confirm that you need to reset the data of the currently indicated model in order to prevent accidental loss of your valuable data.

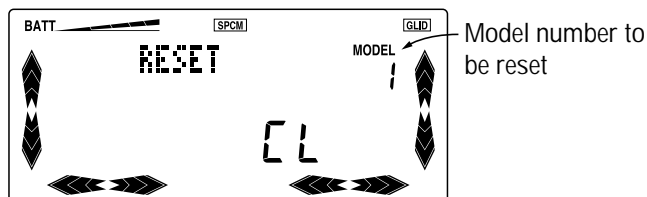

Model number to be reset

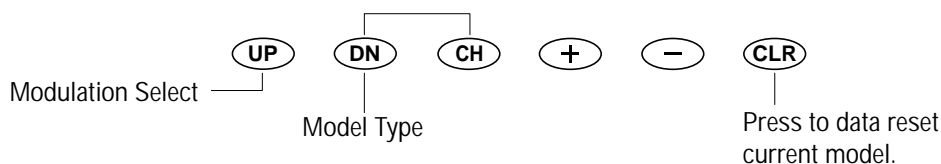

Accessing the Data Reset Function

1. While pressing the *Down* and *Channel* keys, switch the transmitter to the On position to enter the Model Setup mode.
2. Press the *Up* or *Down* key until "RESET" appears in the center of the LCD display. Check the number at the right side of the display to be sure the model selected is the model you want to reset.
3. To reset data, press the *Clear* key.
4. To access the Type Selection function, press the *Down* key.
5. To access the Modulation Selection function, press the *Up* key.
6. To exit the Data Reset function, press both the *Down* and *Channel* keys simultaneously.

CHAPTER 5: INPUT MODE AND FUNCTION • Sailplane

5.8 MODULATION SELECT

The Modulation Selection function enables your X-378 to transmit to a variety of JR receivers that are already, or may soon be, in existence. You can select from either of two types of PCM, Z-PCM or S-PCM,

depending on the Central Processing Unit (CPU) within your receiver or from linear PPM (Pulse Position Modulation [FM]). Refer to the receiver compatibility chart below for the correct modulation.

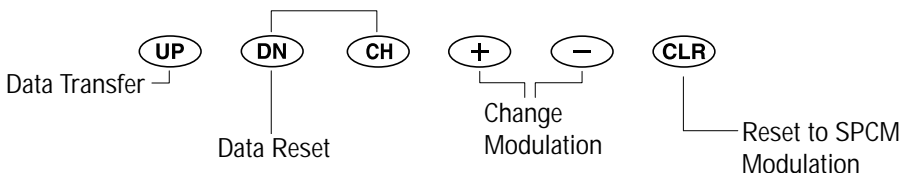
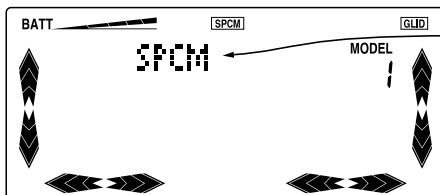

Accessing the Modulation Select Function

1. While pressing the *Down* and *Channel* keys, move the power switch to the On position to access the System mode.
2. Press either the *Up* or *Down* key until "SPCM," "ZPCM," or "PPM" appears at the top of the LCD.
3. To change among the modulation types, press either the (+) or (-) keys.

4. Pressing the *Clear* key will also reset the modulation selection to the factory preset S-PCM.
5. To access the Data Reset function, press the *Down* key.
6. To access the Data Transfer function, press the *Up* key.
7. To exit the Modulation Selection function, press the *Down* and *Channel* keys simultaneously.

Note: When the Data Reset function is used, the X-378 retains the current modulation selected for each model. This means that the modulation type does not change.

Note: In the normal display, the selected modulation type will appear in the middle of the LCD.

Refer to the examples that follow for receiver compatibility:

TX Modulation	Compatible Receivers	# of Channels & Brief Description	TX Modulation	Compatible Receivers	# of Channels & Brief Description
PPM	NER-226	6 (micro)	Z-PCM	NER-236	6 (micro)
PPM	NER-228	8	Z-PCM	NER-627XZ or 627 "G" series	7
PPM (FM)	NER-327x	7	Z-PCM	NER-J329P	9
PPM (FM)	NER-527x	7 (micro)	Z-PCM	NER-910XZ	10
PPM (FM)	NER-529x	9 (micro)	S-PCM	NER-955	10
PPM (FM)	NER-549	9	S-PCM	NER-D945	10
PPM	NER-600	6	S-PCM	NER-649S	9
PPM	NER-610M	6			
PPM	NER-700M	7			

CHAPTER 5: INPUT MODE AND FUNCTION • Sailplane

5.9 DATA TRANSFER FUNCTION

The X-378's Data Transfer function allows for a model from one X-378 transmitter to be sent to another X-378 transmitter by using a JR Trainer Cord (RPA130 sold separately).

Transmitting Transmitter: It will first be necessary to select the desired model (1-8) to be transferred to the receiving transmitter. Access the Model Select function and select the desired model number to be transferred (See section 5.4 for information)

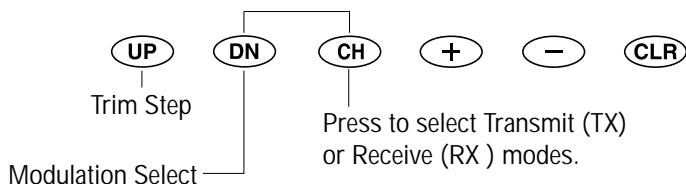
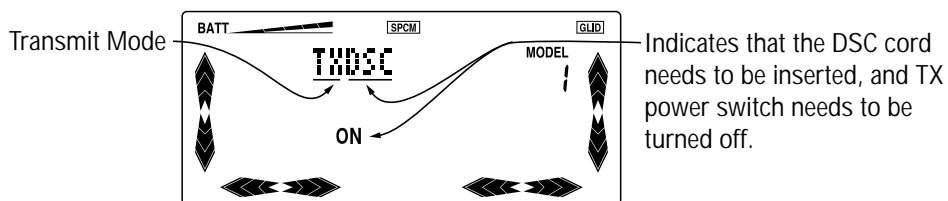

CHAPTER 5: INPUT MODE AND FUNCTION • Sailplane

Transfer Procedure

1. Both transmitters: With the main power switch off, press the *Down* and *Channel* keys simultaneously while turning the power switch on to enter the System mode. The word "TXDSC" will be displayed and flashing.
2. Press the *Channel* key to select Transmit (TXDSC) or Receive (RXDSC) modes.
3. Insert the trainer cord into each transmitter, the letters DSC will be removed from the screen.
4. Turn off the power switch on each transmitter. The screen will then change to read either "TXOUT" or "RXSEL", depending if transmit or receive modes were selected.

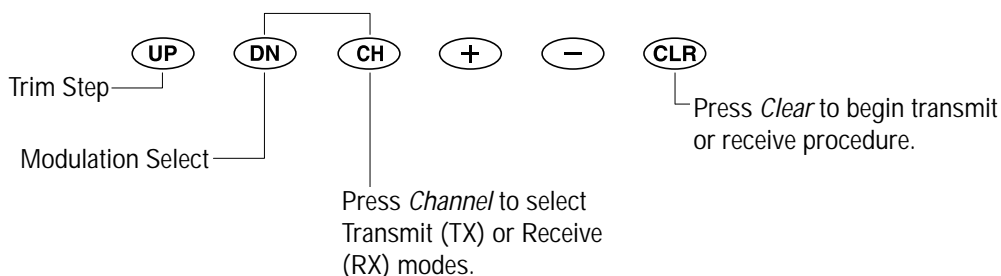
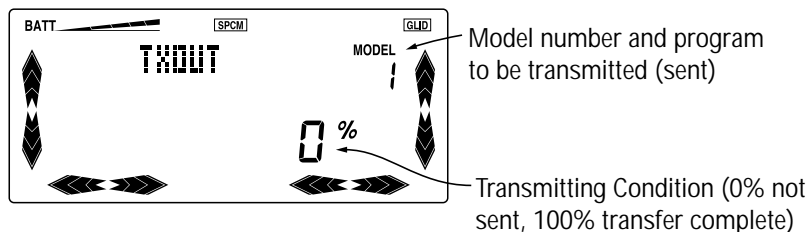

Note: It is also possible to access the Data Transfer function as follows:

1. With the main TX power switch off, press the *Down* and *Channel* keys simultaneously while inserting the trainer cord into the DSC jack of both transmitters. (The transmitters will now be in System mode automatically)
2. Press the *Channel* key to select transmit (TX) or receive (RX) modes.
3. Both transmitters: In the System mode, press the *Up* or *Down* keys until the words "TXOUT" appears on the screen. This is the Data Transfer program.
4. Receiving Mode Transmitter (TX to receive programming): Press the *Channel* key until the screen reads "RXSEL." The word "MODEL" will begin flashing at the top right portion of the LCD directly over the current model number selected.
5. Select the receiving model number by pressing the (+) and (-) keys.



CHAPTER 5: INPUT MODE AND FUNCTION • Sailplane

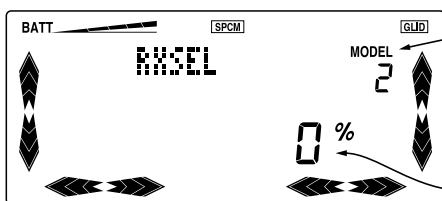

"MODEL" flashing indicates current receiving model number can be selected using the (+) or (-) keys "MODEL" flashing indicates current receiving model number can be selected using the (+) or (-) keys.

Receiving Condition (0% not started, 100% completed)

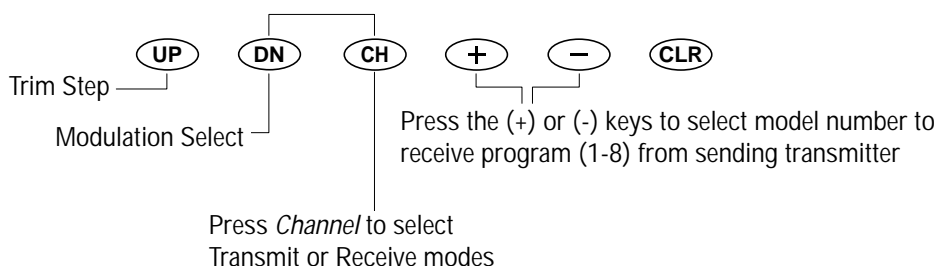

Transmitting Data

7. Press the *Clear* key to activate the receiving standby mode. The word "RX IN" will now be indicated on the screen. The receiving transmitter must be in this

stand by mode before the sending transmitter's *Clear* key is pressed, or the date will not be transferred successfully.

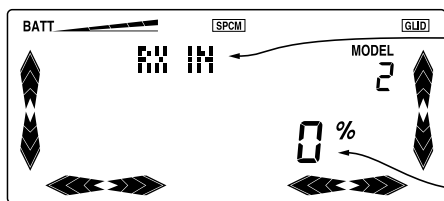

Press the *Clear* key to put the receiving transmitter into Standby mode. The screen will display "RX IN".

Receiving Condition (0% not started, 100% completed)

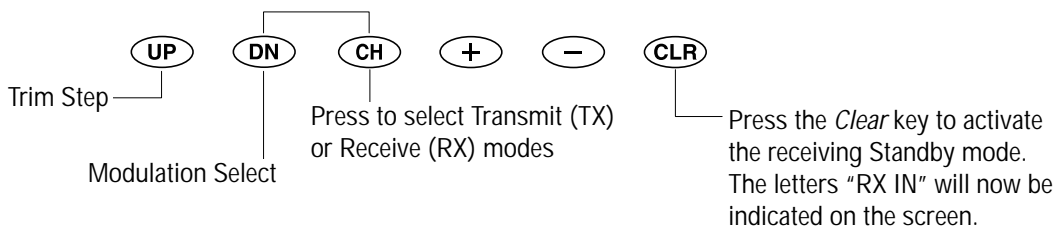

CHAPTER 5: INPUT MODE AND FUNCTION • Sailplane

8. Transmitting mode transmitter (TX with program to be sent): Press the *Clear* key to start transmitting data. If the data transfer was successful, both transmitters will indicate the value 100% on the display when the transmitting is complete.

If there is a data receiving error during transmitting, the counter will stop. At this time, press the *Clear* key to stop the receiving function. If there is any failure of transferring, the display will appear as follows:

RXERR RXERR

When the receiving counter is stopped or you see "ERROR" indicated, check the trainer cord connection and condition and try again. Be sure that the receiving Mode transmitter is in standby condition first. Then on the transmitting transmitter press the *Clear* key to start transmitting.

Note: The Data Transfer function will not work when the battery alarm is flashing.

5.10

TRIM STEP

The Trim Step function allows the user to increase or decrease the coarseness of the servo movement as compared to the steps or beeps of the digital trim. The total servo trim movement remains the same, (approx. 30degree) regardless of the trim step rate selected (1~10). The factory default setting for the trim step function is 4, which means that for each

step (beep) of the digital trim, the servo will move in digital increments of 4. In other words, if a finer trip step value of 1 is selected, the servo will move in a digital increment of 1 for each step (beep) of the digital trim. If a more coarse trim value of 10 is selected, the servo will move in a digital increment of 10 for each step (beep) of the digital trim lever.

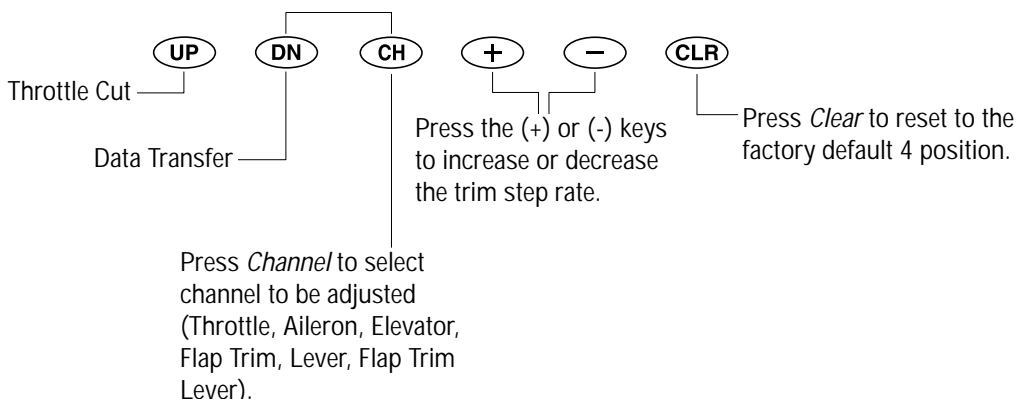
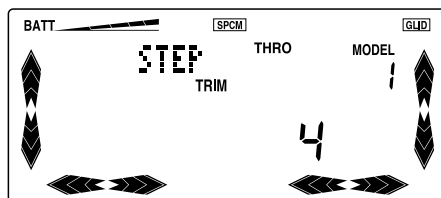

CHAPTER 5: INPUT MODE AND FUNCTION • Sailplane

5.11 V-TAIL/DUAL-FLAP WING MIXING

The V-Tail/Dual-Flap Wing Mixing function found in the X-378 allows the user to set the aircraft type as a V-tail and/or dual-flap wing type.

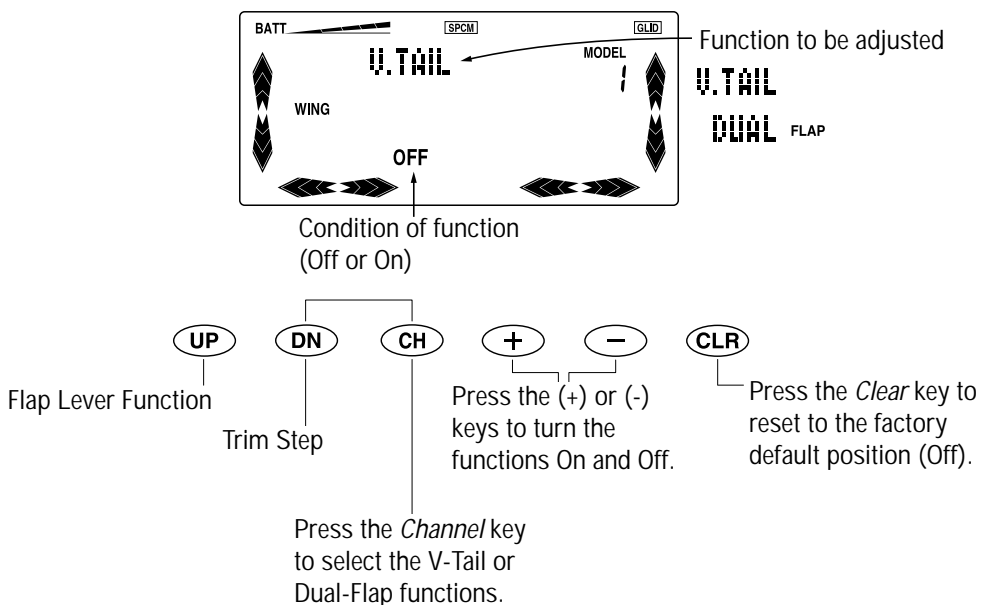

V-Tail Mixing

Connect the left ruddervator to the elevator channel of the receiver and the right ruddervator to the rudder channel of the receiver. When the V-Tail Mix is active, the two surfaces will work together to operate as both elevators and rudders. In the V-tail system, each servo's travel is automatically reduced to 75% of

the normal travel. Dual rate and exponential functions still operate normally. If the direction of the travel is incorrect, the individual servos can be reversed in the Servo Reversing function. The Sub-Trim function can also be used to trim each surface individually.

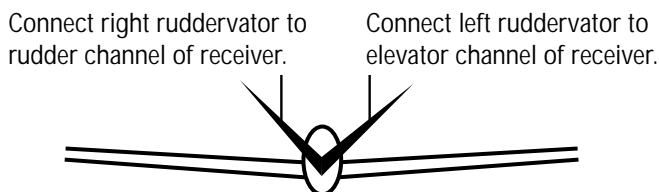

CHAPTER 5: INPUT MODE AND FUNCTION • Sailplane

Dual-Flap Mixing

Connect the left flap servo to the Aux 1 channel of the receiver and connect the right flap to the Aux 2 channel of the receiver. Check the direction that the flaps operate. The direction of the flaps should match the ailerons once the Aileron-to-Flap Mix has been established in the function mode.

Note: The Aileron-to-Flap Mix will only appear in the Function mode after the Dual-Flap Mix has been activated as described below. Use the Aux 2 and flap levers to adjust the trim of the flaps as needed. The Aux 2 and flap levers adjust the position of the two-flap servo in different ways, as determined by the servo direction for each servo.

Example: If the Aux 1 and Aux 2 servos are both in the NORM direction, the Aux 2 lever will move the servos in the same direction, while the flap lever will move the servos in

opposite directions. If either of the Aux 1 or 2 channels is reversed, the Aux 2 Lever will now move the servos in opposite directions, while the flap lever will now move the servos in the same direction.

Note: If the 3-position flap switch is selected to operate the flap function (See section 5.12 Flap Switch Selection), the Aux 2 lever will become inhibited, and the flap lever will function as the flap trim Lever.

The Travel Adjust and Servo Reversing functions can be used to fine tune the flap operation as needed. If necessary, Sub-Trim can be used individually to adjust each flap.

This system requires four servos in the wing: one for each aileron and one for each flap.

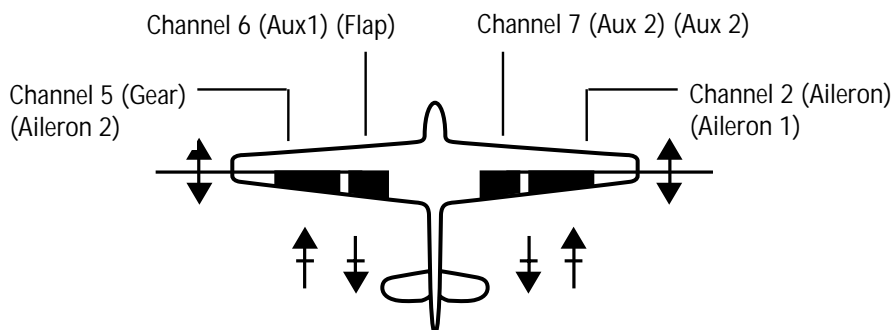

Accessing the V-Tail/Dual Flap Function

1. While pressing the *Down* and *Channel* keys, move the power switch to the On position to access the System mode.
2. Press either the *Up* or *Down* key until "V.TAIL" appears at the top of the LCD.
3. To activate the V-Tail Mix function, press either the (+) or (-) keys.
4. To access the Dual-Flap function, press the *Channel* key. Next, press the (+) or (-) keys to activate the Dual-Flap Mix.
5. To access the Trim Step function, press the *Down* key.
6. To access the Flap Lever function, press the *Up* key.
7. To exit the V-Tail/Dual-Flap function, press the *Down* and *Channel* keys simultaneously.



CHAPTER 5: INPUT MODE AND FUNCTION • Sailplane

5.12 FLAP SWITCH SELECT FUNCTION

The Flap Switch Select function allows the flap channel input to be operated by either the flap lever (proportional) or the Flap Mix switch (3-Position). The flap lever can also be used as a trim lever for the flaps when the Flap Mix switch is selected. When the flap lever is selected, the function is 100% proportional from this lever. Selecting the flap lever and Landing switch (Flap Lever) (FL(+))LS allows for

the flaps to operate in a three-position manner via the Flap Mix switch, with the Flap Lever acting as a trim lever for the flaps.

Note: If the Flap switch is selected (FL+LS) as the main flap channel input, then the Flap Lever will operate as a flap trim. This is the most common Flap switch assignment.

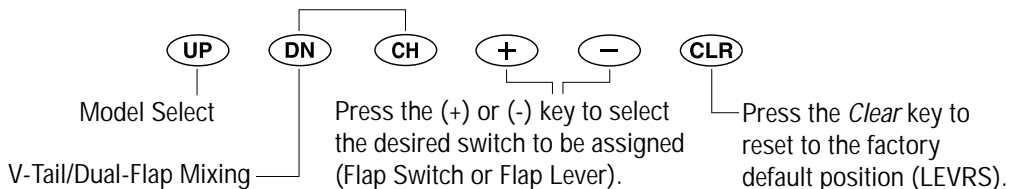
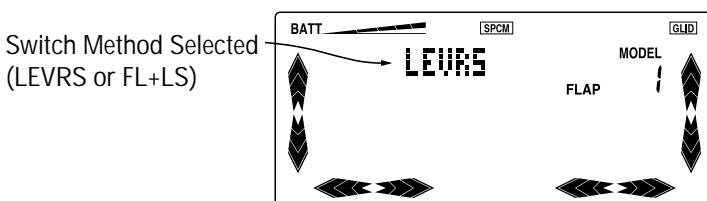

Accessing the Flap Switch Select Function

1. While pressing the *Down* and *Channel* keys, switch the transmitter to the On position to enter the System mode.
2. Press either the *Up* or *Down* key until "FLAP" appears at the upper right portion of the LCD with the letters "LEVRS" in the center of the LCD.
3. Press either the (+) or (-) key to assign the desired switch method (LEVRS or FL+LS)
4. To access the V-Tail/Wing Mixing function, press the *Down* key.
5. To access the Model Select function, press the *Up* key.
6. To exit the Flap/Spoiler Select function, press the *Down* and *Channel* keys simultaneously.



CHAPTER 6: FUNCTIONS (FUNCTION MODE) • Sailplane

6.1 FUNCTION MODE

To enter the Function mode, switch the transmitter power switch to the On position. Press the *Down* and *Channel* keys simultaneously, and the display will show the last active program. Pressing either the *Up* or *Down* key then scrolls through the functions one by one, according to the Function Mode Flowchart shown below. Once the appropriate function is displayed, changes can be made by pressing the (+) or (-) keys. To select another channel of a particular function, press the *Channel* key. If you transfer to a different function that is channel selectable, the display will show the same channel. For example, if you are adjusting the dual rate of the elevator and you change to the Exponential function, the channel remains elevator. The Function mode is the most often used system to input data.

Function Mode Flowchart

Information pertaining to each function is explained on the page listed next to the function name. Functions will appear in the same order they are shown on this chart.

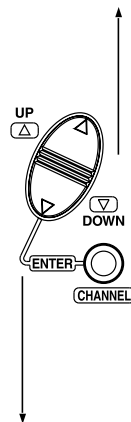

Accessing the Function Mode

1. Move the power switch to the On position.
2. Press the *Down* and *Channel* keys simultaneously.
3. Use either the *Up* or *Down* to scroll through the menu and access the applicable function.

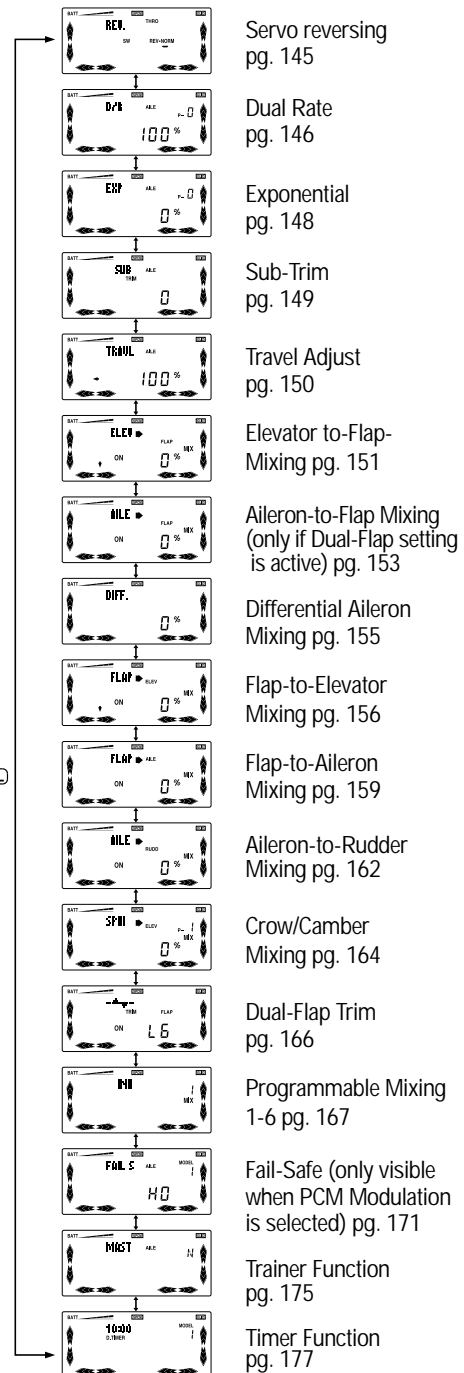

CHAPTER 6: FUNCTIONS (FUNCTION MODE) • Sailplane

6.2 SERVO REVERSING

The Reverse Switch function is an electronic means of reversing the throw of a given channel (servo). All seven channels of the X-378 offer reversible servo

direction. This will ease setup during the servo installation into your aircraft.

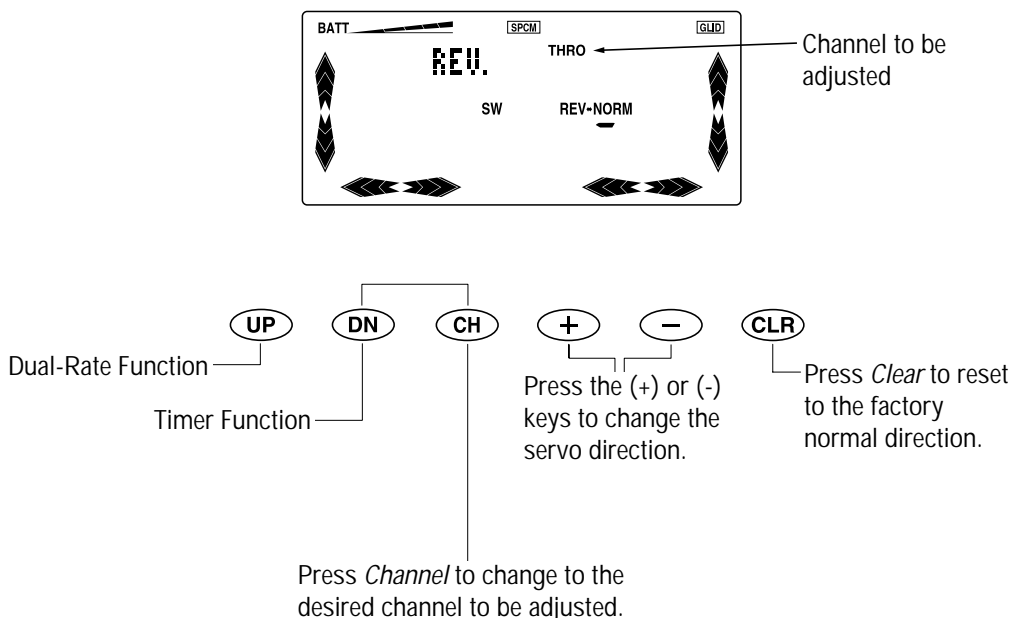

Accessing the Reverse Switch Function

1. Place the transmitter switch in the on position.
2. Access the Function mode by pressing the *Down* and *Channel* keys simultaneously.
3. Press either the *Up* or *Down* key until the "REV." appears in the upper left corner of the LCD.
4. Using your transmitter's control sticks, switches and potentiometers, move the control surfaces of your aircraft. Note the travel direction of each of the corresponding control surfaces.
5. After you have determined which channel(s) need to have the throw directions reversed, use the

- Channel* key to call up the appropriate channel. Press either the (+) or (-) keys to change the travel direction of the servo. Pressing the *Clear* key returns the travel direction to normal.
7. You can observe the change in the travel direction by moving the appropriate control at this time.
8. To access the Timer function, press the *Down* key.
9. To access the Dual Rate function, press the *Up* key.
10. To exit the Reverse Switch function, press the *Down* and *Channel* keys simultaneously.

CHAPTER 6: FUNCTIONS (FUNCTION MODE) • Sailplane

6.3

DUAL RATES

Dual Rates are available for the aileron, elevator and rudder channels of your R/C aircraft. There is also an automatic dual rate setting to link your aileron, elevator, and rudder dual rates to the flight model switch. This Automatic Dual-Rate function is discussed in a separate section that follows. Dual-Rates may be defined as the ability to vary the travel or throw rate of a servo from a switch. Due to the differing travel rates, you will find that the sensitivity of the control either increases or decreases accordingly. A higher rate, or travel, yields a higher overall sensitivity. You may find it easier to think of the Dual-Rate function as double-

rates or half-rates. The Dual-Rate function works in conjunction with the Exponential function to allow you to precisely tailor your control throws. You may want to consult the section defining exponential for further information.

The amount of travel is adjustable from 0-125% in 1% increments. The factory setting, or default value, for both the 0 and 1 switch positions is 100%. Either switch position may be selected as the low or high rate by placing the switch in the desired position and adjusting the value accordingly.

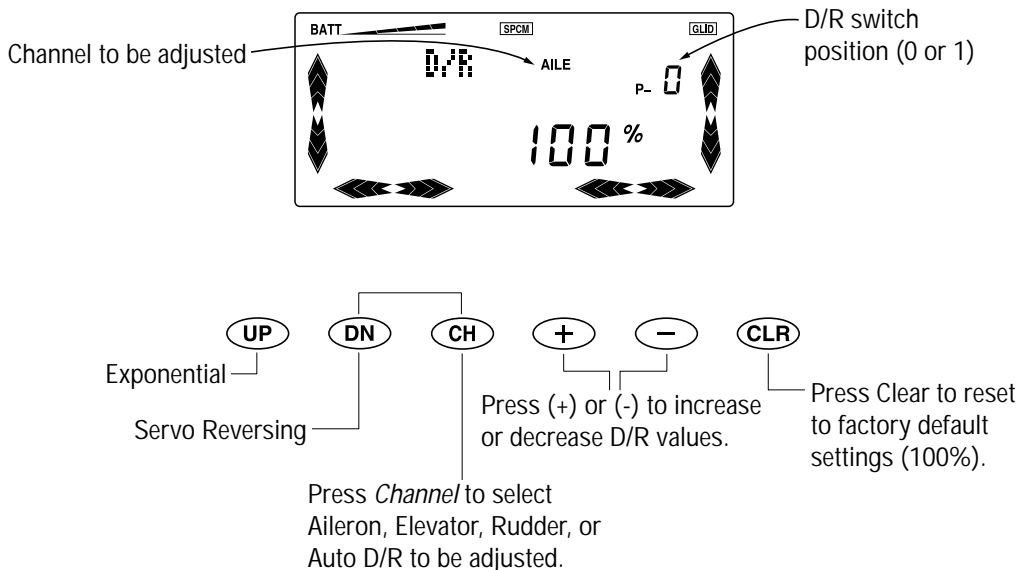

Accessing the Dual-Rate Function

1. Place the transmitter power switch in the on position.
2. Access the Function mode by pressing the *Down* and *Channel* keys simultaneously.
3. Press either the *Up* or *Down* key until "D/R" appears in the upper left corner of the LCD.
4. Press the *Channel* key until the desired channel (aileron, elevator, rudder or automatic Dual-Rates) appears.
5. Select the switch position for which you want to adjust the rate. The number to the upper right of the current rate value on the display indicates the current position of the dual rate switch for the

- channel that you have selected. Either a 0 or a 1 will be shown, corresponding to the position of the switch. To select the opposite switch position, move the appropriate dual rate switch to the opposite position. The number that appears above the current rate value reflects the change.
6. Adjust the rate for the channel and the switch position that you have just selected. To decrease the throw rate, press the (-) key. To increase the throw rate, press the (+) key. The adjustable rate is from 0-125% for each switch position and channel.



CHAPTER 6: FUNCTIONS (FUNCTION MODE) • Sailplane

Accessing the Dual-Rate Function (continued)

Note: You can observe the servo changes by moving the respective stick while increasing or decreasing the values. The control changes accordingly. To clear the Dual-Rate for the respective channel and switch position, press the *Clear* key. After the dual rates have been dialed in to your satisfaction, we suggest that you begin to adjust the exponential values. Refer to the Exponential section for more information.

7. To access the Servo Reversing function, press the *Down* key.

8. To access the Exponential function, press the *Up* key.

9. To exit the Dual-Rate function, press the *Down* and *Channel* keys simultaneously.



CHAPTER 6: FUNCTIONS (FUNCTION MODE) • Sailplane

6.4 EXPONENTIAL

Programmable exponential adjustments are offered on the aileron, elevator, and rudder channels of your R/C aircraft. Exponential is a function that allows you to tailor the response rate of the stick controls. The purpose of exponential is to reduce the sensitivity in the middle portion of stick movement, while still allowing full travel at the end of the stick movement. In other words, the end result (travel) remains the same, although exponential changes the rate at which it achieves this travel.

The adjustable range of the Exponential Function is from 0-100%. Zero percent (0%) is linear stick control

which means that the response rate is equal throughout the stick control. 100% is full exponential. The larger the exponential value, the less servo action or sensitivity you will notice around the neutral setting.

Note: The Exponential function operates in conjunction with the Dual-Rate function. It is imperative to understand the Dual-Rate function prior to adjusting the exponential values. Exponential may be selected for either the high or low rate or both.

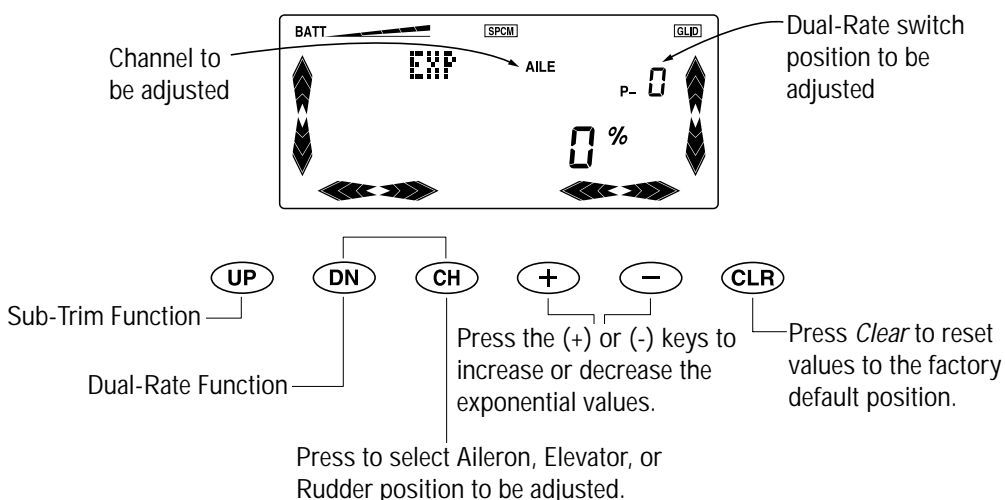

Accessing the Exponential Function

1. Place the transmitter power switch in the On position.
2. Press the *Down* and *Channel* keys simultaneously to access the Function mode.
3. Press either the *Up* or *Down* key until "EXP" (Exponential) appears in the upper left corner of the LCD.
4. Press the *Channel* key until the desired channel (aileron, elevator or rudder) appears.
5. Select the switch position for which you want to adjust the exponential rate. The number directly above the exponential value on the display indicates the current position of the dual rate switch for the channel that you have selected. Either a 0 or 1 will be shown, corresponding to the position of the switch. To select the opposite switch position, move the appropriate Dual-Rate or Flight mode switch to the opposite position. The number that appears directly
6. Adjust the rate for the channel and the switch position that you have just selected. To increase the exponential rate, press the (+) key. As stated previously, the adjustable rate is from linear (0%) to 100% for each switch position and channel.
7. The number that appears directly above the Exponential value will reflect the change.
8. To access the Dual-Rate function, press the *Down* key.
9. To access the Sub-Trim function, press the *Up* key.
10. To exit the Exponential Function, press the *Down* and *Channel* keys simultaneously.

Note: Exponential is an acquired feel. As such, it may take several test flights to achieve the proper amount of exponential that fits your flying style.



CHAPTER 6: FUNCTIONS (FUNCTION MODE) • Sailplane

6.5 SUB-TRIM

The Sub-Trim Adjustment function allows you to electronically fine-tune the centering of your servos. Individually adjustable for all seven channels with a range of $\pm 125\%$ (± 30 degrees servo travel), the sub-trims can be set for the same neutral settings for

each model stored in the transmitter's memory. The Sub-Trim functions provides precise servo arm neutral positioning if rotating the servo arm will not allow the desired servo arm position.

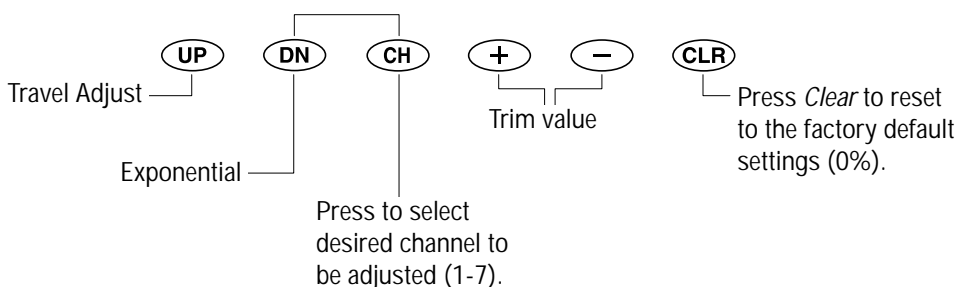
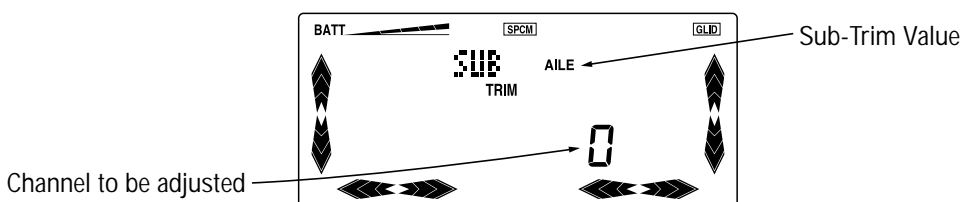

Accessing Sub-Trim Adjustment Function

1. Place the transmitter power switch in the On position.
2. To Access the Function mode, press the *Down* and *Channel* keys simultaneously.
3. Press either the *Up* or *Down* key until "SUBTRIM" appears in the upper middle portion of the LCD.
4. Press the *Channel* key until the desired channel appears.
5. Press the (+) or (-) key to establish the desired amount and direction of Sub-Trim.

Note: A (+) or (-) symbol appears to the left of the sub-trim value to indicate the direction of sub-trim input.

Caution: Do not use excessive Sub-Trim adjustments since it is possible to overrun your servo's maximum travel if it is off-center. Remember that it is a trim convenience function. It is not intended to take the place of the proper mechanical trim adjustments that are necessary on any R/C model. An offset servo will also produce a differential effect.

6. To access the Exponential function, press the *Down* key.
7. To access the Travel Adjust function, press the *Up* key.
8. To exit the Sub-Trim function, press the *Down* and *Channel* keys simultaneously.



CHAPTER 6: FUNCTIONS (FUNCTION MODE) • Sailplane

6.6 TRAVEL ADJUST

The purpose of travel adjust, also known as endpoint adjustment or adjustable travel volume, is to offer you precise servo control deflection in either direction of servo operation. The X-378 offers travel adjust for all seven channels. The travel adjust range

is from 0-150% (0 degrees to 60 degrees) from neutral, or center, and it can be adjusted for each direction individually. The factory default (data reset) value is 100% for each direction of servo travel.

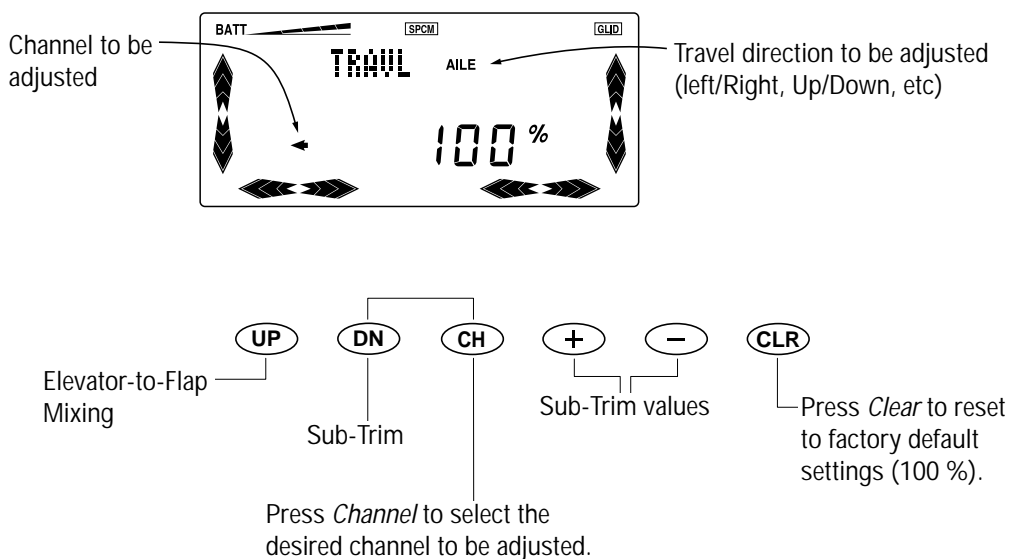

Accessing the Travel Adjust Function

1. Place the transmitter power switch in the On position.
2. Access the Function mode by pressing the *Down* and *Channel* keys simultaneously.
3. Press either the *Up* or *Down* key until "TRAVL" appears in the upper middle portion of the LCD.
4. Press the *Channel* key until the desired channel appears.
5. Move the appropriate control stick (lever, switch, etc) to the right or left of center to the direction of travel you want to adjust. An arrow to the right of the travel adjust value will reflect the current position to be adjusted. Using our example above, if the aileron stick is moved to the left, a left-facing arrow will appear to the left of the travel adjust value on the LCD screen.
6. After the control stick or switch is placed in the direction of travel to be adjusted, press the (+) or (-) key until the proper amount of servo travel is shown on the lower right side of the LCD. Press the (+) key to increase the amount of servo travel. Press the (-) key to decrease the amount of servo travel.
7. Follow the same procedure for the remaining channels.
8. To access the Sub-Trim function, press the *Down* key.
9. To access the Elevator-to-Flap Mixing function, press the *Up* key.
10. To exit the Travel Adjust function, press the *Down* and *Channel* keys simultaneously.



CHAPTER 6: FUNCTIONS (FUNCTION MODE) • Sailplane

6.7 ELEVATOR-TO-FLAP MIXING

When the Elevator-to-Flap Mixing function is active and a value of flaps is input, the flaps will be deflected each time the elevator stick is used. The actual flap movement is adjustable for both up and

down elevator. The most frequently used application is up elevator/down flaps. When used in this manner, the aircraft pitches up much more quickly than normal and is helpful in tight thermal turns.

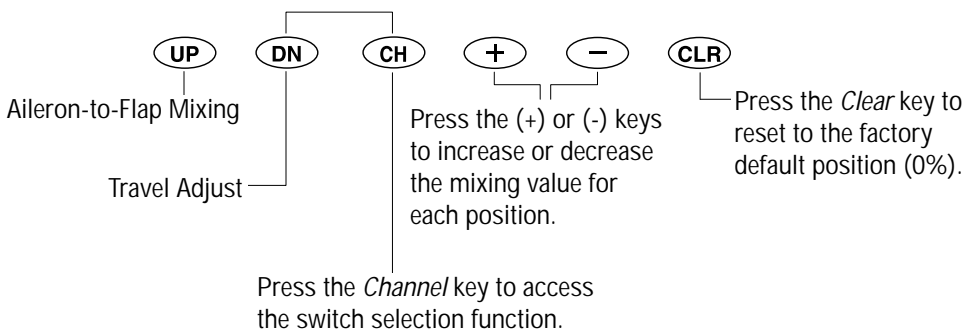
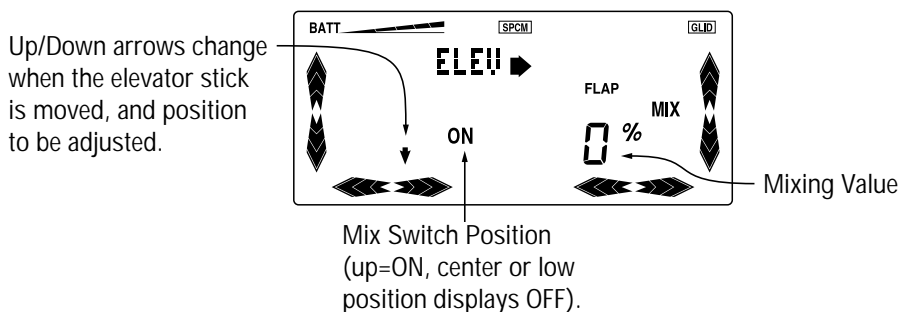

Note: Only the elevator input indicated by the LCD will be cleared. For example, if the *Up* arrow were displayed and *Clear* were pushed, the *Down* arrow value would still be retained by the transmitter. In order to change elevator operating direction, move the elevator control stick in the direction you want to mix with flaps. Using our example, we would input down elevator. The down arrow would be displayed at the lower left portion of the LCD. Our mixing value would also change to reflect our input.

If the Flap-Mixing switch selected is not in the on position, the position indicator on the LCD will change from "ON" to "OFF." This indicates that the Elevator-to-Flap Mixing function is not currently active. Although the current mixing value will still be displayed, it will not be possible to alter this value until the selected mix switch is returned to the On position. Refer to the Elevator-to-Flap Switch Activation section for more information.



CHAPTER 6: FUNCTIONS (FUNCTION MODE) • Sailplane

Accessing the Elevator-to-Flap Mixing Function

1. Place the transmitter power switch in the On position.
2. Access the Function mode. To do so, press the *Down* and *Channel* keys simultaneously.
3. Press either the *Up* or *Down* key until "ELEV-FLAP" appears in the center portion of your LCD.

Note: If the selected Flap-Mixing Switch is not in the uppermost position, the position indicator will read "OFF." The selected Flap-Mixing switch must be in the on position in order to make adjustments to the flap-mixing value.

4. Move the elevator stick in the direction you want to mix with flaps.

Note: The position indicator will reflect this change by replacing the up arrow with a down arrow or vice-versa. A Down arrow indicates up elevator, and an Up arrow indicates down elevator (The arrow position indicates stick position, not elevator direction.)

5. Press the (+) or (-) key to increase or decrease the amount of flaps to be mixed. If you want to reverse

the flap travel, press the *Clear* key, bringing the mixing value to the factory default (0%), and increase the value using the opposite key (+) or (-) from the key originally selected.

6. Once you have adjusted the first mixing position (Up or Down), place the elevator stick in the opposite direction and follow Step 5 above to adjust the second elevator mixing value.
7. To access the Travel Adjust function, press the *Down* key.
8. To access the Aileron-to-Rudder Mixing function, press the *Up* key.
9. To exit the Elevator-to-Flap Mixing function, press the *Down* and *Channel* keys simultaneously.

Elevator-to-Flap Mixing Switch Selection

The X-378 allows for the use of either of two switches (three switch positions) for the activation of the Elevator-to-Flap Mixing function. You can also enable the Elevator-to-Flap Mixing function so that it remains active at all times. The Elevator-to-Flap Mixing function is generally used for multi-task duration, speed, distance, and slope aerobatics. You may want to use different mix values for up and down elevator positions.

LCD Display	Description
ON	The Elevator-to-Flap Mixing function will remain on at all times.
MIX	The Elevator-to-Flap Mixing function is activated/inhibited by the Rudder D/R/Mix switch located on the upper rear of the Tx.
FLP-D	The Elevator-to-Flap Mixing function is only activated when the flap switch is in the lower (launch) position.
FLP-U	The Elevator-to-Flap Mixing function is only activated when the flap switch is in the upper (reflex) position.

Accessing the Elevator-to-Flap Mixing Switch Selection

1. Place the transmitter power switch in the On position.
2. Access the Function mode. To do so, press the *Down* and *Channel* keys simultaneously.
3. Press either the Up or Down key until "ELEV-FLAP" appears in the center portion of your LCD.
4. Press the *Channel* key once to access the Switch Selection function.
5. Press the (+) or (-) keys to select the desired switch to assign the mix to.
6. Press the Channel key again to return to the Elevator-to-Flap function.
7. To access the Travel Adjust function, press the *Down* key.
8. To access the Aileron-to-Flap Mixing function, press the *Up* key.
9. To exit the Elevator-to-Flap Mixing function, press the *Down* and *Channel* keys simultaneously.



CHAPTER 6: FUNCTIONS (FUNCTION MODE) • Sailplane

6.8 AILERON-TO-FLAP MIXING (Dual-Flap Activated in System Mode)

The Aileron-to-Flap Mixing function is only applicable when the Dual-Flap Trim function is activated in the System mode. For information on how to activate the Dual-Flap Trim function, refer to the V-Tail/Dual-Flap function. The purpose of this mixing function is to mix the ailerons with the flaps so that the flaps will operate in conjunction with the ailerons. In effect, this will increase the amount of aileron control surface area available. The amount of mix is adjustable; thus, you can tailor the aileron response to fit your flying style. The flap lever on the front right face of the X-378 transmitter will trim the flap channel (Aux1) as ailerons. The digital aileron

trim lever will trim the ailerons (aileron channel). The digital aileron trim has no effect on the flaps.

Note: If differential mixing is being used, the flaps will also operate differentially according to the value input in the differential mixing. This mixing will also include the aileron operating value when programmable mixing 1 or 2 is used with the ailerons. If the Aileron-to-Flap Mixing activation switch is in the Off position, the Aileron-to-Flap Mixing would be inhibited. Off would replace the On switch indication in our example.

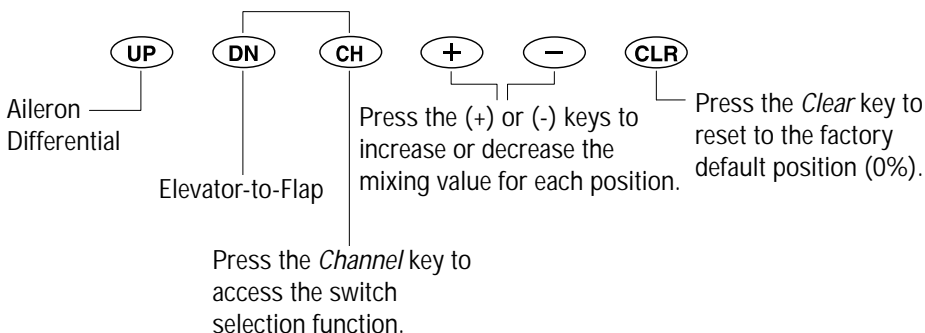
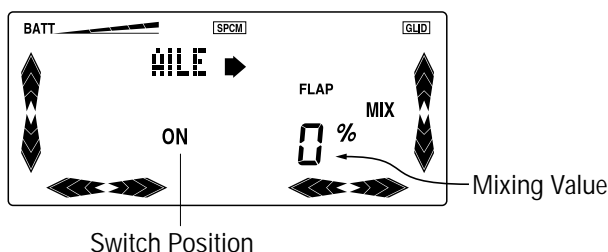

Accessing the Aileron to Flap Mixing Function

1. While pressing the *Down* and *Channel* keys move the power switch to the On position.
2. Press either the *Up* or *Down* key until "AILE-FLAP" is displayed in the center portion of the LCD.
3. Press either the (+) or (-) key to change the value of the mix. A (+) or (-) sign will appear to the left of the current value. This indicates the direction of travel. If the travel is in the wrong direction, increase

the value in the opposite direction. Normal application is that the flaps travel the same direction as the ailerons.

4. After the Aileron-to-Flap Mixing values have been adjusted, you can select the desired mixing switch to activate the Aileron-to-Flap Mix. You can also choose to leave the Mixing function on at all times (factory default).



CHAPTER 6: FUNCTIONS (FUNCTION MODE) • Sailplane

Aileron-to-Flap Mixing Activation Selection

The purpose of the Aileron-to-Flap Mixing Activation Selection is to enable you to select a switch and/or switch position that will activate the Aileron-to-Flap

Mixing function. You can also choose to leave the Aileron-to-Flap Mix active at all times.

LCD Display	Description
ON	The Aileron-to-Flap Mixing function will remain on at all times.
MIX	The Aileron-to-Flap Mixing function is activated/inhibited by the Rudder D/R/Mix switch located on the upper rear of the transmitter.
FLP-D	The Aileron-to-Flap Mixing function is only activated when the flap switch is in the lower (launch) position.
F-U/D	The Aileron-to-Flap Mixing function is activated when the flap switch is in the upper and lower (reflex) positions. The mix is off or inhibited when the switch is in the center position. This mix is often used with Launch mode (preset) also for aerobatics, speed and distance tasks.

Accessing the Aileron-to-Flap Mixing Switch Selection

1. Place the transmitter power switch in the On position.
2. Access the Function mode by press the *Down* and *Channel* keys simultaneously.
3. Press either the *Up* or *Down* key until "AILE-FLAP" appears in the center portion of your LCD.
4. Press the *Channel* key once to access the Switch Selection function.
5. Press the (+) or (-) keys to select the desired switch to assign the mix to.
6. Press the *Channel* key again to return to the Aileron-to-Flap function.
7. To access the Elevator-to-Flap function, press the *Down* key.
8. To access the Aileron Differential function, press the *Up* key.
9. To exit the Aileron-to-Flap Mixing function, press the *Down* and *Channel* keys simultaneously.



CHAPTER 6: FUNCTIONS (FUNCTION MODE) • Sailplane

6.9 DIFFERENTIAL AILERON MIXING

The X-378 transmitter offers aileron differential. Differential ailerons are used to tailor the flight control system to a particular aircraft. Because the downward travel of the aileron creates more drag than does the upward travel, it is necessary to reduce the amount of down travel for each aileron electronically. This drag may very well produce a yawing tendency in your aircraft. As yaw is undesirable in most R/C aircraft, it is best to correct

for this common flight tendency. Aileron differential overcomes the yaw as it reduces the downward travel of the ailerons.

Note: When the Dual-Flap Trim function is active, the differential value will also apply to the flapperons. Differential may also be obtained by using the Travel Adjust function.

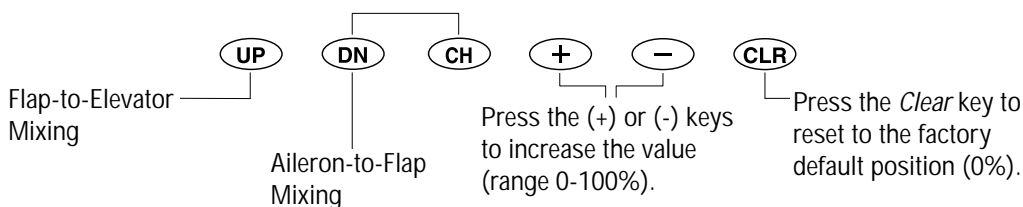
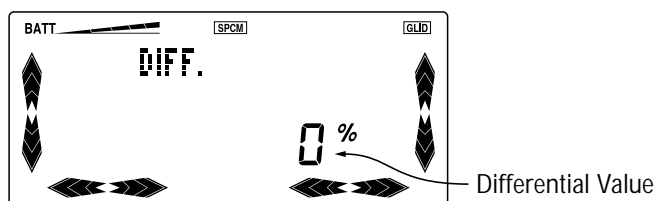

Accessing the Differential Aileron Mixing Function

1. Place the transmitter switch in the On position.
2. Press the *Down* and *Channel* keys simultaneously to enter the Function mode.
3. Press either the *Up* or *Down* key until "DIFF." appears in the upper left corner of the LCD. Press the (+) or (-) key until the desired amount of differential is established. The operating range for differential is 0% (NORM) to 100% (SPLIT). The following diagrams may ease the understanding of the Differential Aileron Mixing function:
4. To access the Aileron-to-Flap Mixing function, press the *Down* key.
5. To access the Flap-to-Elevator function, press the *Up* key.
6. To exit the Aileron Differential Mixing function, press the *Down* and *Channel* keys simultaneously.

If left at 0%, the ailerons maintain equal travel for both sides. That is, there will not be any differential whatsoever. If set at 50%, the aileron that is lowered travels 50% or half, as far as the upward aileron. If adjusted to 100%, you achieve what is commonly referred to as a "split." This means that the only aileron that moves is the aileron that travels upward. The aileron that normally drops remains stationary.



CHAPTER 6: FUNCTIONS (FUNCTION MODE) • Sailplane

6.10 FLAP TO ELEVATOR MIXING

When the Flap-to-Elevator Mixing function is active and a value for elevator is input, the elevator will be deflected accordingly each time the flaps are used. The actual elevator movement is adjustable for both up and down flaps. Thus, the elevator is used to eliminate the pitch up or pitch down tendency when the flaps are raised or lowered. This function also includes a mixing offset to redefine the neutral position of the elevator channel. The effect of the offset is to change the point at which the mixing actually begins.

Note: To change the flap operating direction to be adjusted (up or down), move the selected flap activation switch to the second activation position. The arrow on the LCD

will change from an up to a down arrow or vice versa to indicate the current flap position to be adjusted.

The X-378 allows for the Flap-to-Elevator Mixing to be left on at all times or turned on and off by a switch position. For information, refer to the Flap-to-Elevator Mixing Activation Selection section.

If the elevator mixing activation switch is in the Off position, the Flap-to-Elevator Mixing function would be inhibited. Off would replace the percentage (0%) in our example. This mix generally will be used as the launch preset trim for the elevator. You can also adjust preset trim for reflex.

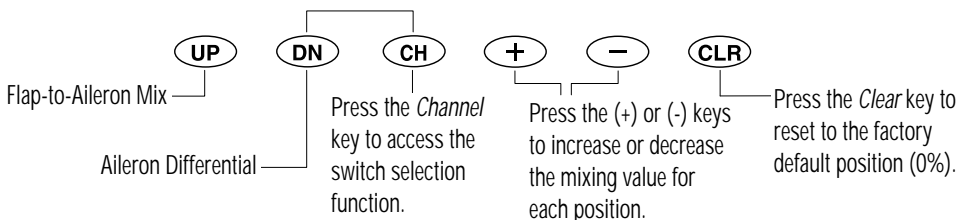
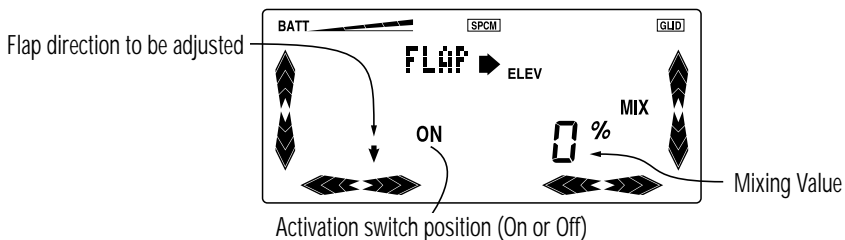

CHAPTER 6: FUNCTIONS (FUNCTION MODE) • Sailplane

Accessing the Flap-to-Elevator Mixing Function

1. Place the transmitter power switch in the On position.
2. Access the Function mode by pressing the *Down* and *Channel* keys simultaneously while the power switch is in the On position.
3. Press either the *Up* or *Down* key until “FLAP-ELEV” appears in the center portion of your LCD.

Note: If “OFF” appears in the lower left portion of the LCD, move the flap switch to the opposite position from the one it currently occupies. If “OFF” is still on the LCD, move the mixing switch.

4. Move the Flap Mix switch until the desired flap position to be adjusted is displayed on the LCD (up or down arrow)

Note: As the flap switch is moved, the *Up* and *Down* Arrows at the lower left of the LCD will change to the appropriate flap operating direction.

5. Press either the (+) or (-) key to increase or decrease the amount of elevator input. If the elevator is moving in the wrong direction, i.e., opposite of the direction you want to mix with the flaps, Change the current mixing value from (+) to (-) or vice versa to change the mixing direction.

Flap-to-Elevator Mixing Activation Selection

The purpose of the Flap-to-Elevator Mixing Activation Selection function is to enable you to select a switch and/or switch position that will activate the Flap-to-Elevator Mixing function. You can also choose to leave the Flap-to-Elevator Mix active at all times.

LCD Display	Description
ON	The Flap-to-Elevator Mixing function will remain on at all times.
MIX	The Flap-to-Elevator Mixing function is activated/inhibited by the Rudder D/R/Mix switch located on the upper rear of the transmitter.
FLP-D	The Flap-to-Elevator Mixing function is only activated when the flap switch is in the lower (launch) position.
F-U/D	The Flap-to-Elevator Mixing function is activated when the flap switch is in the upper and lower (reflex) positions. The mix is off or inhibited when the switch is in the center position.

Accessing the Flap-to-Elevator Mixing Switch Selection

1. Place the transmitter power switch in the On position.
2. Access the Function mode by pressing the *Down* and *Channel* keys simultaneously.
3. Press either the *Up* or *Down* key until “FLAP-ELEV” appears in the center portion of your LCD.
4. Press the *Channel* key once to access the Switch Selection function.
5. Press the (+) or (-) keys to select the desired switch to assign the mix to.
6. Press the *Channel* key again to return to the Flap-to-Elevator function.
7. To access the Aileron Differential function, press the *Down* key.
8. To access the Flap-to-Aileron function, press the *Up* key.
9. To exit the Flap-to-Elevator Mixing function, press the *Down* and *Channel* keys simultaneously.



CHAPTER 6: FUNCTIONS (FUNCTION MODE) • Sailplane

Activation Switch Offset

The offset feature redefines the neutral position of the selected mix activation switch. The effect of this is to change the point where mixing actually begins to take place relative to the switch position selected.

1. Press the *Channel* key until "OFFSET" appears in the center of the LCD.
2. Move the assigned mix switch to the position that you want to establish as the starting point for the mix.
3. Press the *Clear* key to store the offset value. The

offset value will generally be + or - 171, depending on the mix switch position.

4. Press the *Channel* key again to return to the Flap-to-Elevator function.
5. To access the Aileron Differential function, press the *Down* key.
6. To access the Flap-to-Aileron function, press the *Up* key.
7. To exit the Flap-to-Elevator Mixing function, press the *Down* and *Channel* keys simultaneously.



CHAPTER 6: FUNCTIONS (FUNCTION MODE) • Sailplane

6.11 FLAP-TO-AILERON MIXING

The purpose of the Flap-to-Aileron Mixing function is to allow you to couple the ailerons to the flaps. This will enable you to droop the ailerons with the flaps to increase lift. If you should find it necessary to redefine the neutral position of the ailerons relative to the mix switch position, a mixing offset is also provided.

mix, if utilized. The offset position for the Flap-to-Aileron Mix can also be altered as needed.

In order to use the Flap-to-Aileron function, it will be necessary to employ one servo per aileron and at least one on the flaps.

Note: The offset value for the Flap-to-Aileron Mixing function will initially be the same as the point established for the Flap-to-Elevator

This mixing system will include the flap operating value when programmable mixing 1 or 2 is applied to the flaps.

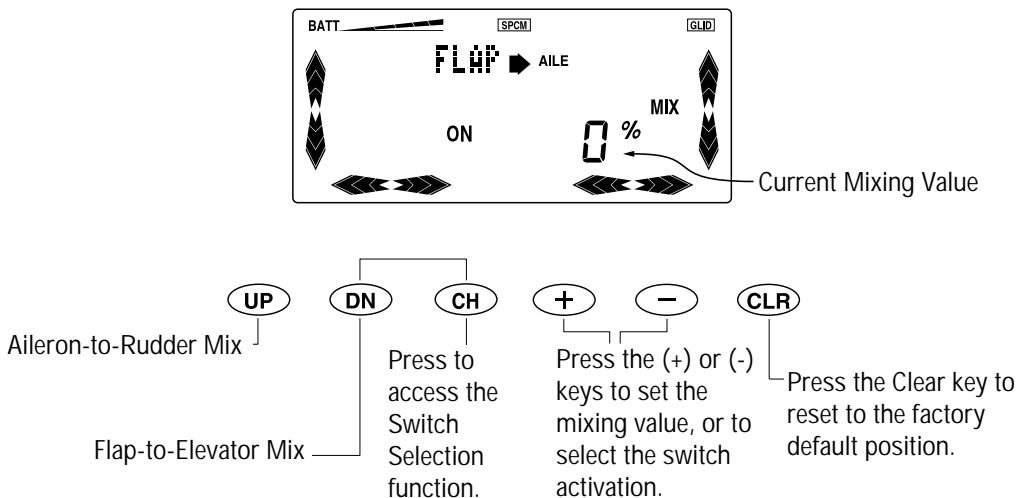

Flap-to-Aileron Mixing Activation Selection

The purpose of the Flap-to-Aileron Mixing Activation Selection function is to enable you to select a switch and/or switch position that will activate the Flap-to-

Aileron Mixing function. You can also choose to leave the Flap-to-Aileron active at all times.

LCD Display	Description
ON	The Flap-to-Aileron Mixing function will remain on at all times.
MIX	The Flap-to-Aileron Mixing function is activated/inhibited by the Rudder D/R/Mix switch located on the upper rear of the transmitter.
FLP-D	The Flap-to-Aileron Mixing function is only activated when the flap switch is in the lower (launch) position.
F-U/D	The Flap-to-Aileron Mixing function is activated when the flap switch is in the upper and lower (reflex) positions. The mix is off or inhibited when the switch is in the center position.



CHAPTER 6: FUNCTIONS (FUNCTION MODE) • Sailplane

Accessing the Flap-to-Aileron Mixing Switch Function

1. Place the transmitter power switch in the On position.
2. Access the Function mode by pressing the *Down* and *Channel* keys simultaneously.
3. Press either the *Up* or *Down* key until "FLAP-AILE" appears in the center portion of your LCD.
4. Press the *Channel* key once to access the Switch Selection function.
5. Press the (+) or (-) keys to select the desired switch to assign the mix to.
6. Press the *Channel* key again to return to the Flap-to-Aileron function.
7. To access the Flap-to-Elevator function, press the *Down* key.
8. To access the Aileron-to-Rudder Mix function, press the *Up* key.
9. To exit the Flap-to-Elevator Mixing function, press the *Down* and *Channel* keys simultaneously.

Note: If the Aileron Mixing activation switch is in the Off position, the Flap-to-Aileron mixing would be inhibited.

Adjusting the Flap-to-Aileron Mixing Function

1. Place the transmitter power switch in the On position.
2. Access the Function mode by pressing the *Down* and *Channel* keys simultaneously while the power switch is in the On position.
3. Press either the *Up* or *Down* key until "FLAP-AILE" appears in the center portion of your LCD.
4. Press either the (+) or (-) key to increase the amount of aileron to be mixed with flaps. Moving the flap switch (located on the front left face of the transmitter) will now move both the ailerons and the flaps.
5. After the mixing percentage is input, select the switch and/or position for which you want to activate the Flap-to-Aileron Mixing function. You can also choose to leave the Mixing function enabled (ON) at all times. To select the mixing activator, press the *Channel* key. Your display will appear as follows:
6. Press either the (+) or (-) key to select among the mixing activators. For more information on the mixing activators refer to the Flap-to-Aileron Mixing Activation Selection section.

Note: If "OFF" appears in the lower left portion of the LCD, move the flap switch to the opposite position from the one it currently occupies. If "OFF" is not replaced with "ON," repeat this procedure with the mixing switch.



CHAPTER 6: FUNCTIONS (FUNCTION MODE) • Sailplane

Activation Switch Offset

The offset feature redefines the neutral position of the selected mix activation switch. The effect of this is to change the point where mixing actually begins to take place relative to the switch position selected.

1. Press the *Channel* key until "OFFSET" appears in the center of the LCD.
2. Move the assigned mix switch to the position that you want to establish as the starting point for the mix.
3. Press the *Clear* key to store the offset value. The

offset value will generally be + or - 171, depending on the mix switch position.

4. Press the *Channel* key again to return to the Flap-to-Aileron function.
5. To access the Aileron to Rudder Mix function, press the *Up* key.
6. To access the Flap-to-Elevator function, press the *Down* key.
7. To exit the Flap-to-Aileron Mixing function, press the *Down* and *Channel* keys simultaneously.



CHAPTER 6: FUNCTIONS (FUNCTION MODE) • Sailplane

6.12 AILERON-TO-RUDDER MIXING

This form of mixing is designed so that when input to the aileron stick is given, the rudder servo will also move, eliminating the need to coordinate these controls manually. When adjusting, if an opposite mixing direction of the rudder servo is required, simply press the (+) or (-) keys to change the mixing value from a + to - or a - to a +. This will reverse the

mixing direction of the rudder from its original direction. The switch used to activate this mix can also be selected as explained below. The factory default mix switch for the Aileron-to-Rudder Mix function is Rudder D/R/ Mix switch located at the upper right side of the transmitter.

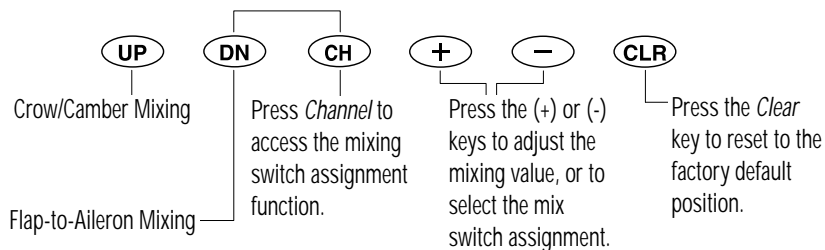
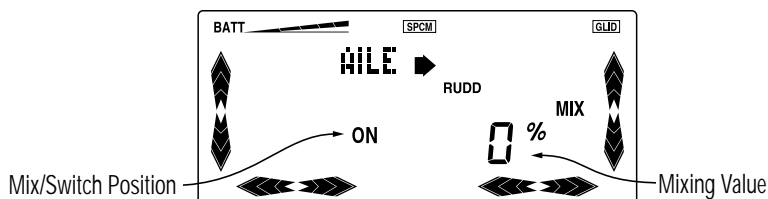

Accessing the Aileron-to-Rudder Mixing Function

1. Place the transmitter power switch in the On position.
2. Access the Function mode. To do so, press the *Down* and *Channel* keys simultaneously.
3. Press either the *Up* or *Down* key until "AILE-RUDD" appears in the center portion of your LCD.

Note: If the current mixing switch is not in the on position, the position indicator will read "OFF." The current mixing switch must be in the On position in order to make adjustments to the Aileron-to-Rudder mixing value.

4. With the current mix switch On, press the (+) or (-) key to increase or decrease the amount of rudder to be mixed with aileron. If you want to reverse the rudder mix direction, press the *Clear* key, bringing the mixing value to the factory default (0%) and increase the value using the opposite key (+) or (-) from the key originally selected.
5. To access the Elevator-to-Flap Mixing function, press the *Down* key.
6. To access the Landing Mode function, press the *Up* key.
7. To exit the Aileron-to-Rudder Mixing function, press the *Down* and *Channel* keys simultaneously..



CHAPTER 6: FUNCTIONS (FUNCTION MODE) • Sailplane

Assigning the Mixing Activation Switch

The Aileron-to-Rudder Mixing program can be turned on and off using several different assignable switch options.

The mix is off or inhibited when the switch is in the center position.

This mix is often used with launch mode (preset) also for aerobatics, speed and distance tasks.

LCD Display	Description
ON	The Aileron-to-Rudder Mixing function will remain on at all times.
MIX	The Aileron-to-Rudder Mixing function is activated/inhibited by the Rudder D/R/Mix switch located on the upper rear of the transmitter.
FLP-D	The Aileron-to-Rudder Mixing function is only activated when the flap switch is in the lower (launch) position.
F-U/D	The Aileron-to-Rudder Mixing function is activated when the flap switch is in the upper and lower (reflex) positions.

Assigning the Aileron-to-Rudder Mixing Switch Function

1. Place the transmitter power switch in the On position.
2. Access the Function mode by pressing the *Down* and *Channel* keys simultaneously.
3. Press either the *Up* or *Down* key until "AILE-RUDD" appears in the center portion of your LCD.
4. Press the *Channel* key to access the switch assignment function.
5. Press the (+) or (-) key to select the desired switch/function to activate the Aileron-to-Rudder Mixing function.
6. To access the Flap-to-Aileron Mixing function, press the *Down* key.
7. To access the Crow/Camber Mixing function, press the *Up* key.
8. To exit the Aileron-to-Rudder Mixing function, press the *Down* and *Channel* keys simultaneously.



CHAPTER 6: FUNCTIONS (FUNCTION MODE) • Sailplane

6.13 Crow/Camber Mixing

The purpose of this function is to allow the ailerons to be used as spoilers in conjunction with the normal spoilers and flaps. You can also choose to include a preset amount of up or down elevator to avoid pitching up or down when the crow/camber

system is active. This system is activated using the gear switch on the top left corner of the transmitter and increasing the spoiler (throttle) stick. This will deploy the crow/camber system as speed brakes.

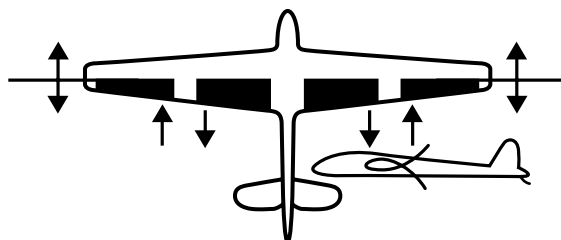

Two different setups are available for the crow/camber mixing function, one for each position of the crow on and off switch. A mixing offset is also

available to redefine the neutral position of the spoiler system.

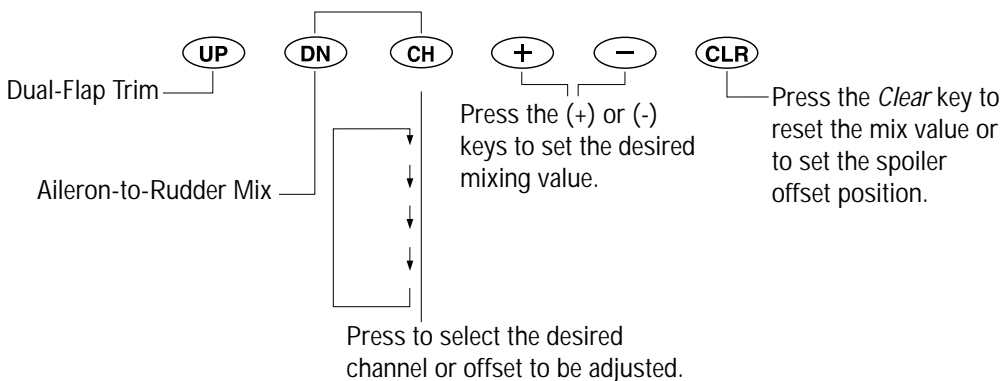
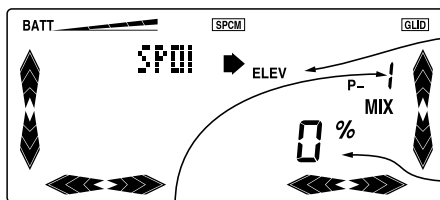

CHAPTER 6: FUNCTIONS (FUNCTION MODE) • Sailplane

Accessing the Crow/Camber Mixing Function

1. Move the transmitter switch to the On position.
2. Press the *Down* and *Channel* keys simultaneously to enter the Function mode.
3. Press either the *Up* or *Down* key until "SPOI" appears in the center left portion of the LCD.
4. Place the crow/camber switch (GEAR) in the position you want to be the On position (0 or 1).
5. Press the *Channel* key until the channel on which you want to set the value appears to the right of "SPOI."

Note: The switch position appears just to the right of this display. Press either the (+) or (-) key to increase or decrease the individual mix values for each of these channels. Press the *Channel* key again until all channel values are input. Normal operation is ailerons up, flaps down.

Setting the Spoiler Offset Position

If you want to use the spoiler offset:

6. Press the Channel key until "OFFSET" appears in the center portion of the LCD.
7. Move the spoiler (throttle) stick to the desired offset position (usually full low stick) and press the *Clear* key. The offset is now saved. The normal position is spoiler (throttle) stick low.
8. To access the Aileron-to-Rudder Mixing function, press the *Down* key.
9. To access the Dual-Flap Trim function, press the *Up* key.
10. To exit the Crow/Camber Mixing function, press the *Down* and *Channel* keys simultaneously.



CHAPTER 6: FUNCTIONS (FUNCTION MODE) • Sailplane

6.14 Dual-Flap Trim (when Dual-Flap is selected in the System mode)

The purpose of the Dual-Flap Trim function is to allow the trimming of the two flap channels (Aux 1 and Aux 2). Two separate trim Levers are accessible in the Dual-Flap Trim function. The Aux 2 Lever, located on the front Left face of the transmitter, adjusts both flap control surfaces up/down in unison (L6 on the LCD). The Flap Lever, located on the front right face of the transmitter, trims the flaps in opposite directions as ailerons (L5 on the LCD).

Note: The Dual-Flap Trim function must be active. Also, the aileron ratchet trim has no effect on the flaps.

In order for "L5" to appear on the LCD, the Flap Trim activation must be selected to FL+LS in the System mode in addition to the Dual-Flap Mixing function. Refer to the Flap Channel Input Selection and Wing Mixing sections respectively (System mode) for more information.

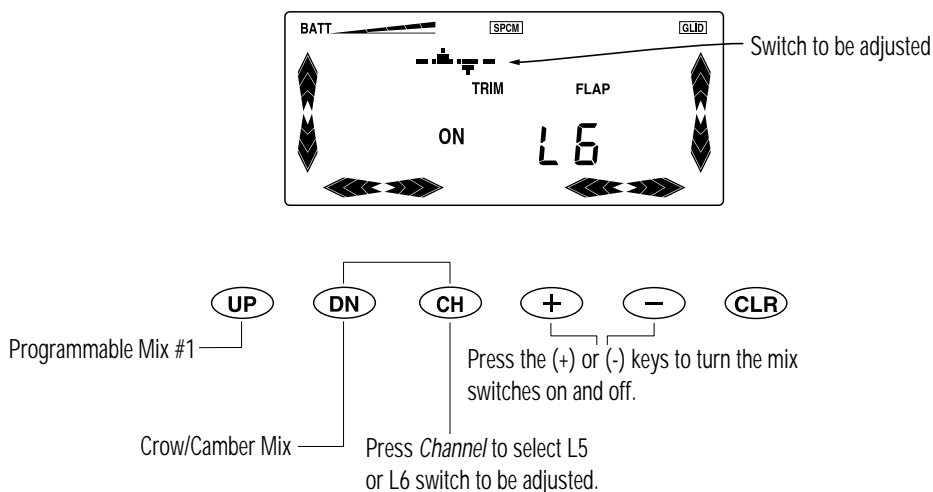

Accessing the Dual-Flap Trim Function

1. Place the transmitter switch in the On position.
2. Access the Function mode by pressing the *Down* and *Channel* keys simultaneously while the power switch is On.
3. Press either the *Up* or *Down* key until "TRIM" appears in the center portion of the LCD below the Dual-Flap Trim icon.
4. Press the (+) or (-) key to activate the L6 trim. The display will change to indicate "ON."
5. If the Dual-Flap Trim function is active and FL+LS is selected (System mode), press the Channel key until L5 is displayed.
6. Once L5 is indicated, press either the (+) or (-) key to activate the trim feature. The display will change to "ON." Now the Aux 2 and flap levers may be used to make in-flight adjustments to these control surfaces.
7. To access the Crow/Camber Mixing function, press the *Down* key.
8. To access Programmable Mix #1, press the *Up* key.
9. To exit the Dual-Flap Trim function, press the *Down* and *Channel* keys simultaneously.



CHAPTER 6: FUNCTIONS (FUNCTION MODE) • Sailplane

6.15 PROGRAMMABLE MIXING 1-6

The X-378 offers six programmable mixes to be used for any number of different purposes. This function allows mixing any one channel to any other channel to make the aircraft easier to fly. This mix can remain on at all times, or be switched on and off in flight using a number of different switches.

Mix numbers 1-4 are of the standard variety, in that the digital trim for the master channel only affect the master channel, and not the slave channel. Mix numbers 5 and 6 are of the "Trim Include" variety. These mixes are used any time the mix you are performing requires the Slave channels trim position to be varied when the master channel's digital trim position is varied. An example for this type of mix would be when dual-elevator or dual-aileron servos are used, and connected to two separate channels of the system, rather than using a single channel with a Y-Harness.

Each channel of this radio is identified by an abbreviated name. The chart below indicates the

channel and its corresponding abbreviation. The channel name appearing first is known as the "master channel" or the channel to which you want to mix. The second number is known as the "slave channel" or the channel that is being mixed into the master channel. For example, "AILE-RUDD" would indicate Aileron-to-Rudder Mixing. Each time the aileron stick is moved, the aileron will deflect, and the rudder will automatically move in the direction and to the value input. Mixing is proportional, so small inputs of the master channel will produce small outputs of the slave channel. Each programmable mix has a mixing "offset." The purpose of the mixing offset is to re-define the neutral position of the slave channel.

- | | | |
|----|-------|---------------|
| 1. | THRO | Spoiler |
| 2. | AILE | Left Aileron |
| 3. | ELEV | Elevator |
| 4. | RUDD | Rudder |
| 5. | AIL | Right Aileron |
| 6. | FLAP | Left Flap |
| 7. | AUX 2 | Right Flap |

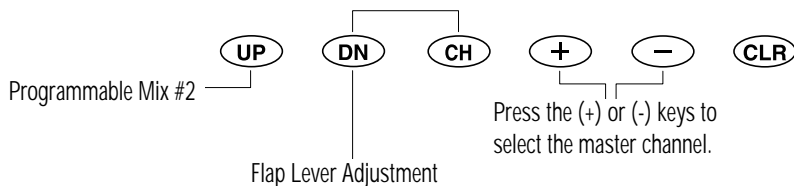
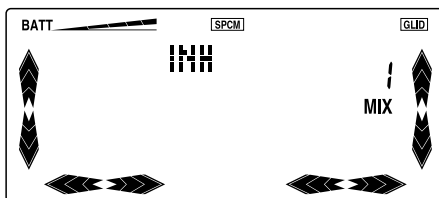

- | | | |
|----|-------|---------------|
| 1. | SP01 | Spoiler |
| 2. | AILE | Left Aileron |
| 3. | ELEV | Elevator |
| 4. | RUDD | Rudder |
| 5. | GEAR | Right Aileron |
| 6. | AUX 1 | Left Flap |
| 7. | AUX 2 | Right Flap |



CHAPTER 6: FUNCTIONS (FUNCTION MODE) • Sailplane

Accessing the Programmable Mixing Function

1. Place the transmitter switch in the On position.
2. Press the *Down* and *Channel* keys simultaneously to enter the Function mode.
3. Press either the Up or Down key until "MIX 1" appears in the upper right portion of the LCD.

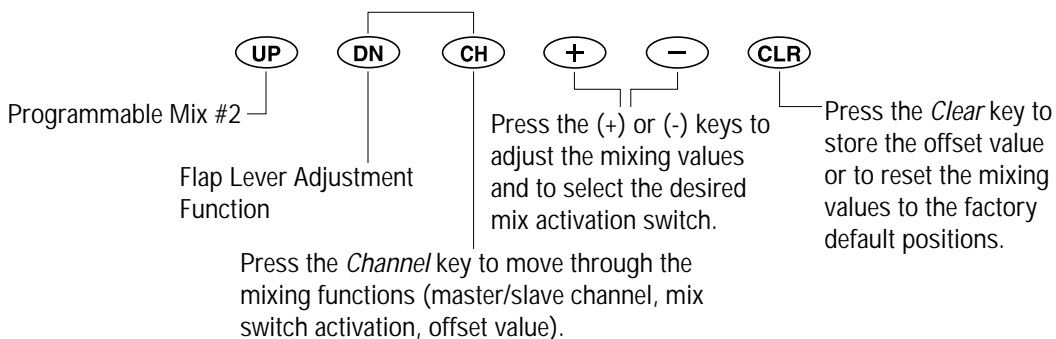
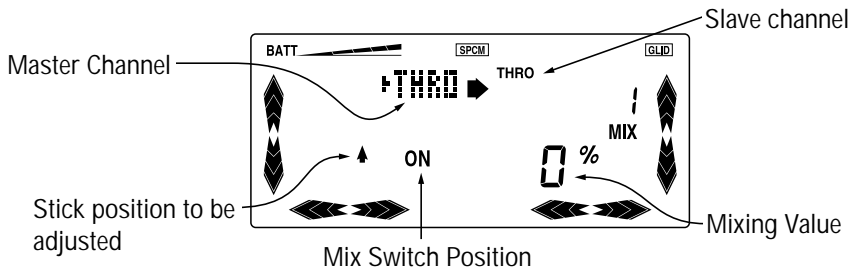

Selecting the Master and Slave Mixing Channels

4. Press the (+) key to activate the mix. Press the (+) or (-) keys again to select the master channel.
5. Press the *Channel* key to move the cursor to the Slave channel position.
6. Press the (+) or (-) keys to select the slave channel.
7. Press the *Channel* key once. The display will continue to show the current mixing channels at the top of the LCD, but will now have a flashing arrow at the bottom left of the LCD to indicate the current stick position (master) to be adjusted.

Setting the Mixing Values

8. While holding the master stick in the direction you want to mix, press the (+) or (-) keys to increase or decrease the mixing value for the slave channel. The

value at the lower right of the LCD will change to display the current mix value selected. Next, hold the master stick to the other side to adjust the mix for the other direction.

Note: The current mixing switch must be in the On position for the mixing values to be adjusted.

Setting the Mixing Switch Activation

9. Press the *Channel* key once again. The display will have SW ON indicated at the center portion of the LCD with the word "ON" located in the upper right of the LCD. This indicates the current switch assignment to activate this mix. "ON" indicates that this mix is currently selected to always be active (ON).



CHAPTER 6: FUNCTIONS (FUNCTION MODE) • Sailplane

Accessing the Programmable Mixing Function (continued)

The mix switch options for Mixes #1, 4, and 5 are:

ON	Always On
MIX	Activated by the RUDD D/R/Mix switch
FLP-D:	Activated in the down position of the Flap Mix switch
FLP-U	Activated in the up position of the Flap Mix switch

The Mix switch options for Mixes # 2, 3, and 6 are

ON	Always On
MIX	Activated by the RUDD D/R/Mix switch
BTFYO:	Activated in the forward position of the Butterfly Mix switch (GEAR)
BTFY1	Activated in the rearward position of the Butterfly Mix switch (GEAR)

Setting the Mixing Channel Offset

9. Press the *Channel* key once again. The display will show the current mixing channels at the top of the LCD, with the word "OFFSET" at the center of the LCD. The value to the lower right is the mixing offset neutral point, currently 0.

10. Hold the master stick in the position you want to make the neutral point of the slave channel and push the *Clear* key. A new value with a (+) or (-) sign will appear. This is the new neutral point for the slave channel (point that the mix is activated). To reset the value back to 0, move the master stick back to the center position and press the *Clear* key to reset.

Note: The master channel trim must be centered for this to reset to 0 using the *Clear* key.

11. Press the *Down* and *Channel* keys simultaneously to exit the Programmable Mix function.

Note: With a little practice, programmable mixing will become easier compared with the first time you try it. The best part of a computer radio is that if you don't like something, you can change it. Mixing is only limited by your imagination.

Setting Mixing Value

The X-378 transmitter has six multi-purpose programmable mixes available. For these mixing operations, first determine the mix type required (standard 1-4, or trim include 5-6), master and slave channels, offset and operating switch settings, if necessary, and then adjust the mixing value.

For setting mixing value, move and hold the master channel control (up, down, left or right) and set the slave servo mix value by pressing either the (+) or (-) keys. To reverse direction of the slave mix, press the opposite of the (+) or (-) keys until the value of mix is set in the reverse direction. If the reference of the offset point is moved (see section below), the slave channel's direction will change from that position.

Setting the Mix Offset Position

Any position of the master channel can be used as a reference (starting) point for mixing. This is useful for channels that have no neutral position. With this function, you can use program mixing with respect to an arbitrary position of the lever/switch. To set the offset position, put the master channel at the desired position and press the *Clear* key. The position is stored in the memory and its offset value from the neutral position is indicated numerically on the display. Once this offset point has been set, the mixing value at the offset position is now set to zero.

CHAPTER 6: FUNCTIONS (FUNCTION MODE) • Sailplane

Functions Related to Program Mixing

The functions related to the operating range of the master channel are as follows:

Mixing 1 and 2

Selecting FLAP (Aux 1) for the master channel:
When the slave channel is aileron (AILE), its mixing operation is affected by aileron differential settings. When the slave channel is flap (FLAP), its mixing operation is affected by Flap-to-Aileron Mix setting. When Dual-Flap setting is active and the slave channel is AUX 2, its mixing operation is affected by aileron differential settings.

Mixing 3 and 4

When the master channel is throttle (spoiler), its mixing operation is affected by the spoiler trim settings.

Trim Include Mixes 5 and 6

Programmable Mixes 5 and 6 offer mixing with the Trim Include function. The Trim Include function is automatically activated when mixes 5 and 6 are used.

Mixes 5 and 6 with Trim Include

Whenever the master channel is aileron, elevator, rudder or throttle, you have the option of allowing the master channel's trim lever to mix into the slave channel. As stated previously, the Mixing with Trim function is always activated in mixes 5 and 6. You can observe the operation by watching the slave channel while moving the master channel's trim lever.

Note: If you have not yet entered values for the mixing percentages, the slave channel will remain stationary. Also, if the mixing percentages are very low, the movement of the slave channel from the trim lever is also very small.

Include Mixing

The Include Mixing function allows other programmed mixing values for the master channel. As stated previously, the Include Mixing function is always activated in Mixes 5 and 6.

For example,

Mix 5: AILE - THRO
Mix 6: THRO - RUDD

Mix 6's operating value also now includes the operating value from Mix 5's master channel (aileron). By moving the aileron control stick, Mix 5 has the ailerons mixing into the throttle, and now also the rudder from Mix 6. At the same time, Mix 6 is mixing the throttle into the rudder only. Since the Include Mixing is always active, you are also mixing your ailerons into the rudder. This results in the aileron stick moving not only the aileron servo but also the throttle and rudder servos.

Include Mixing may sound complex, but it actually eliminates the need for a third mixing program to mix the aileron and rudder channels. Therefore, Include Mixing reduces the number of mixing programs needed when using multiple mixing functions.

Mixing Operation and Switches

As mentioned previously, each mixing program can be turned on and off by a lever or switch. The levers and switches that can be selected for program mixing are tabulated at the right with their abbreviations appearing on the display and their corresponding positions.

The mix switch options for Mixes #1, 4, and 5 are:

ON: Always On
MIX: Activated by the RUDD D/R/Mix Switch
FLP-D: Activated in the Down position of the Flap Mix switch
FLP-U: Activated in the Up position of the Flap Mix switch

The Mix switch options for Mixes # 2, 3, and 6 are:

ON: Always On
MIX: Activated by the RUDD D/R/Mix switch
BTFYO: Activated in the Forward position of the Butterfly Mix switch (GEAR)
BTFY1: Activated in the Rearward position of the Butterfly Mix switch (GEAR)



CHAPTER 6: FUNCTIONS (FUNCTION MODE) • Sailplane

6.16 FAIL-SAFE/HOLD FUNCTION (PCM ONLY)

The Fail-Safe/Hold function is available only when you use the X-378 transmitter in either of the PCM modulations-S-PCM or Z-PCM. This function is designed to help minimize damage to your aircraft during a loss of signal to the receiver. The servos either assume the fail-safe presets or hold their last good signal position.

Note: In the PCM modulations, the Fail-Safe/Hold function cannot be totally disabled so that the servos will react to interference in the same way as they do in a PPM (FM) system. This is only possible with the use of a

PPM receiver and the transmitter in the PPM modulation. Since the actual screen appearance varies depending on the modulation of your radio, refer to the appropriate modulation section that follows. If you are in the PPM modulation, the Fail-Safe/Hold function is not applicable. Therefore, the Fail-Safe/Hold function will not appear on your LCD screen menu while in the PPM mode. Refer to the Modulation Selection section for more information pertaining to the broadcast signal of your X-378 transmitter.

Accessing the Fail Safe/Hold Function in Z PCM Modulation

Hold (Z-PCM)

The Hold Function is automatically activated when the radio is turned on and is in the Z-PCM modulation. This function stops (or holds) the servos in the positions they were in just prior to the

interference. Therefore, your aircraft maintains the position held immediately before the interference was experienced. When a clear signal is restored, the Hold function releases, and control of the airplane returns to you.

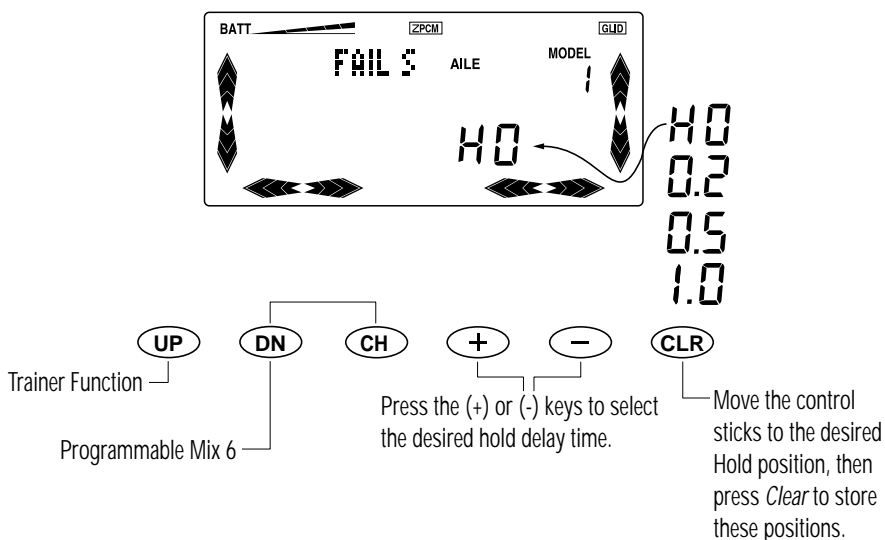

CHAPTER 6: FUNCTIONS (FUNCTION MODE) • Sailplane

Accessing the PCM Hold Function (Z-PCM)

1. Place the transmitter power switch in the On position.
2. Press the *Down* and *Channel* keys simultaneously to access the Function mode.
3. Press either the *Up* or *Down* key until the "FAIL-S" (fail-safe) appears in the upper left portion of the LCD.

Note: If "Fail-Safe" does not appear on your LCD, it is because you are transmitting in PPM. Fail-Safe is not applicable in the PPM mode. Refer to the Modulation Mode Selection section for more information. You should never attempt to adjust the Fail-Safe function when the aircraft is running.

When the Fail-Safe function is activated (i.e., when the signal is interrupted), the transmitter automatically moves each servo to a preset position. The position that each servo assumes is determined by you, as is the time length of interference that must occur before servo movement.

After the interference has ceased, control of the aircraft returns immediately to you. There are three time delays to choose from: 0.25 second, 0.5 second and 1.0 second. These time delays are the amount of time it takes, starting the moment the interference occurs, until the servos assume their preset positions.

Setting the Fail-Safe/Hold Memory in Z-PCM Modulation

1. After accessing the Fail-Safe function, it is time to adjust the Fail-Safe presets.
2. Select among the three time delays (.25, .50 or 1.0 second). Press the (+) or (-) key until the appropriate delay appears on the screen.
3. Hold the transmitter sticks in the positions that you want the servos to assume during signal loss conditions. You can determine fail-safe preset positions for the other channels by placing the other channel switches in the positions that you want them to assume during interference.
4. With the sticks and switches in the desired fail-safe positions, touch the *Clear* key. This will enter these locations as the fail-safe memory settings. A single high-pitched beep will be heard when the *Clear* key is pressed indicating that the positions have been memorized.
5. To confirm that the input of data was successful, switch the transmitter off. The controls will move to the input locations. If not, repeat step 4 again.

Note: These preset positions remain stored in the transmitter's memory until both the transmitter battery pack and the lithium backup battery have been removed (or until data reset has been performed). Therefore, you do not have to reset the fail-safe each time you fly. Should you want to re-adjust the fail-safe presets, access the Fail-Safe function and adjust the presets as you have just done. The transmitter automatically recalls the settings for the last Fail-Safe adjustment.

6. To access the Programmable Mix 6 function, press the *Down* key.
7. To access the Trainer function, press the *Up* key.
8. To exit the fail-safe function, press the *Down* and *Channel* keys simultaneously.



CHAPTER 6: FUNCTIONS (FUNCTION MODE) • Sailplane

Accessing the Fail-Safe/Hold Function in S-PCM Modulation

Hold (S-PCM) The S-PCM Hold function is automatically activated when the radio is turned on and is in the S-PCM modulation. This function stops (or holds) the servos in the positions they were in just prior to the interference. Therefore, your aircraft

maintains the position held immediately before the interference was experienced. When a clear signal is restored, the Hold function releases, and control of the aircraft returns to you.

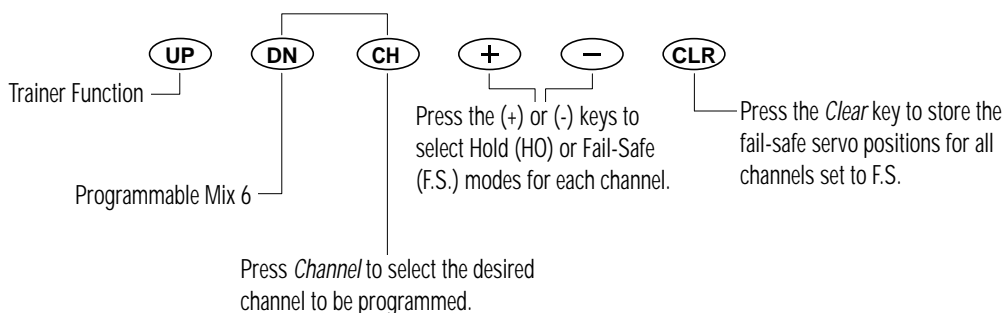
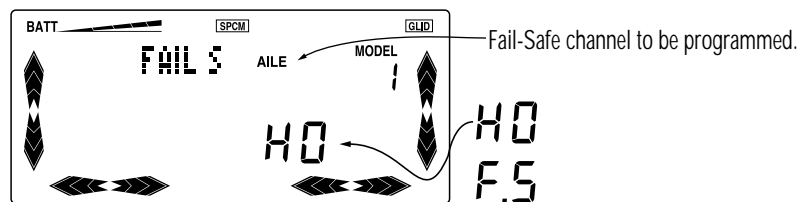

1. Place the transmitter power switch in the On position.
2. While the power switch is in the On position, press the *Down* and *Channel* keys simultaneously to access the Function mode.
3. Press either the *Up* or *Down* key until the "FAIL-S" (fail-safe) appears in the upper left portion of the LCD.

Note: If "Fail-Safe" does not appear on your LCD, it is because you are transmitting in PPM. Fail-Safe is not applicable in the PPM mode. Refer to the Modulation Mode Selection Section for more information.

CHAPTER 6: FUNCTIONS (FUNCTION MODE) • Sailplane

Fail Safe/Hold Combination in S-PCM Modulation

The X-378 allows you to combine the Hold and Fail-Safe presets for all seven channels on the receiver - you can select fail-safe or hold independently for all channels on your aircraft. In other words, some channels will hold their last clear signal position (Hold), while others assume the preset position (Fail-Safe). Once the fail-safe has been activated by signal interruption (interference), the transmitter automatically moves the servos to a preset position.

The predetermined servo positions are set by you. In the S-PCM Fail-Safe, the time delay (the amount of time it takes, starting the moment the interference occurs, until the servos assume the preset positions) is fixed at .25 seconds. After the interference has ceased, normal operation of the aircraft returns to you immediately.

Setting the Fail Safe/Hold Memory in S-PCM Modulation

1. First, select all of the channels for which you want to enter a fail-safe preset. To do so, use the *Channel* key until the appropriate channel name appears in the upper right portion of the LCD. We will use the aileron (AILE) for our example. The display will appear as shown above.
2. Press either the (+) or (-) key. This will change the display from Hold (HO) to the Fail-Safe (F.S.) preset display.
3. Repeat steps #1 and #2 for all channels desired to be set to the Fail-Safe (F.S.) position.
4. Hold all of the appropriate transmitter control sticks and switches in the desired positions and press the *Clear* key. This will enter the location as the fail-safe memory setting for all channels selected to F.S. When the *Clear* key is pressed, a single high-pitch beep will be heard indicating that the Fail-Safe positions have been stored.
5. Hold the aileron stick to the right and press the *Clear* key.
6. To confirm that the input of data was successful to the applicable channels, switch the transmitter off.

All channels selected to Fail-Safe (F.S.) should to their selected positions.

Note: These preset positions remain stored in the transmitter's memory until both the transmitter battery pack and the lithium backup battery have been removed (or until the Data Reset function has been utilized). Therefore, you do not have to reset the Fail-Safe each time you fly. Should you want to re-adjust the fail-safe preset position, access the Fail-Safe function once again and adjust the presets as you have just done. The transmitter automatically recalls the settings for the latest fail-safe adjustment.

7. To access the Programmable Mix 6 function, press the *Down* key.
8. To access the Trainer function, press the *Up* key.
9. To exit the Fail-Safe/Hold function, press the *Up* and *Down* keys simultaneously..



CHAPTER 6: FUNCTIONS (FUNCTION MODE) • Sailplane

6.17 TRAINER SYSTEM

The X-378 transmitter employs two separate types of trainer systems:

1) Normal Trainer System

All functions are controlled by either the master transmitter (MAST) or the slave transmitter (SLAVE)

2) Programmable Function Trainer

Individual channel functions may be assigned to the slave one at a time. Since the control functions can be transferred one by one, students can concentrate on only one function at a time until they are competent to fly solo with all controls.

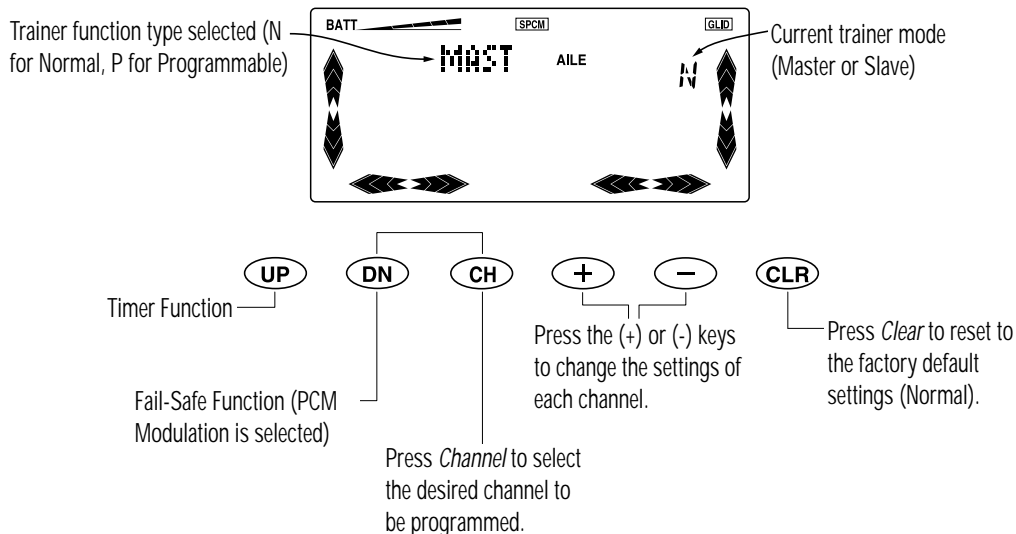

Accessing the Programmable Trainer Function

1. Move the transmitter switch to the On position.
2. Press the *Down* and *Channel* keys simultaneously to enter the Function mode.
3. Press the *Up* or *Down* keys until "MAST" appears on the center portion of the LCD.
4. Press the *Channel* key to select the channel to be adjusted. The channel name will be displayed just to the right of "MAST."
5. Once the channel appears that you want to make a slave, press the (+) or (-) key. This will change the display from "MAST" to "SLAVE." The "N" at the upper right portion of the LCD will also change to P. If you want to make more slave channels, press the *Channel* key until the next desired channel is shown and press the (+) or (-) key to change the settings..

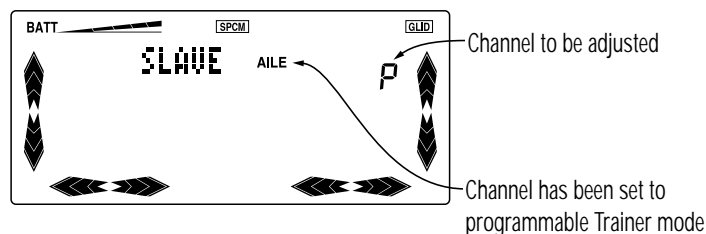

6. To change the Programmable Trainer function back to the Normal Trainer system, press the Clear key.
7. To access the fail-safe function, press the Down key.
8. To access the Timer function, press the Up key.
9. To exit the Trainer function, press the *Down* and *Channel* keys simultaneously.



CHAPTER 6: FUNCTIONS (FUNCTION MODE) • Sailplane

Basic Corrections and Conditions for Training

1. The slave transmitter must be PPM (Pulse Position Modulation) and must be equipped with a DSC (Direct Servo Control) or trainer jack. If the slave transmitter is PPM/PCM selectable, select PPM. The master transmitter can be PCM or PPM.
2. Plug the trainer cord (optional part #JRPA130) into each transmitter's DSC/Trainer jack.
3. Switch the master transmitter on. Do not switch on the slave transmitter; it is only necessary to have the master transmitter on.

Note: Each transmitter will appear to be on, but neither is actually transmitting at this time.

Note: If the master transmitter is the X-378, the LCD will indicate "TRINR" (Trainer Master) and will list the channels that have been programmed when the power switch is on.

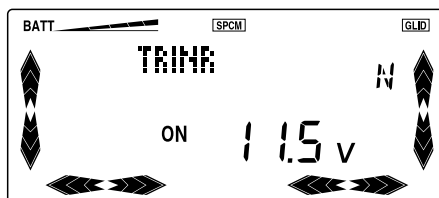

4. Pull the trainer switch toward you to transfer control to the slave. Releasing the switch automatically reverts to the master transmitter.
5. Be sure the slave transmitter's servo reversing, dual rates, end-point adjustment and trims are identical to the master transmitter. This can be checked by pulling the trainer switch toward you. If the control surfaces move, adjust the slave transmitter until the trainer switch can be activated without a change of the control surface position.

Use of the Normal Trainer System

In this mode, all functions are switched from the master to the slave using the trainer switch. This is

the Normal mode-no function setup is necessary to activate this system.

Use of the Programmable Trainer Function

In this mode, the master may assign functions to the student one at a time to make learning to fly easier. For example, the master may assign the slave aileron and elevator. Then, when the trainer switch is activated (pulled forward), the slave has control of aileron and elevator only while the master retains control of throttle and rudder.

Note: When all channels are set to master, the Trainer System becomes normal.



CHAPTER 6: FUNCTIONS (FUNCTION MODE) • Sailplane

6.18

TIMER FUNCTION

The X-378 offers two separate types of timer functions: Countdown and Stopwatch. The Countdown timer time is input in 10-second intervals up to 35 minutes. The timer can be set for each individual model and retained in the memory for each model. Once the Timer function has been activated, it can be started and stopped from the normal display screen using the *Channel* key. It can also be started and stopped using the snap roll/trainer button located at the front right portion of the transmitter. When the X-378 is being used as the master transmitter in the Training function, the trainer switch will not operate the timer start/stop function, and the timer function cannot be used.

Note: In the Countdown mode, the transmitter will beep three times at 30 seconds, two times at 20 seconds, and beep one time every second from 10 to 0. At zero there will be a continuous tone for 1 second and then the timer will begin counting up with a + indication to the left of the time value. When used as the Stopwatch, the timer will count up to 44 minutes, 59 seconds, at which time it will reset to zero and continue to count.

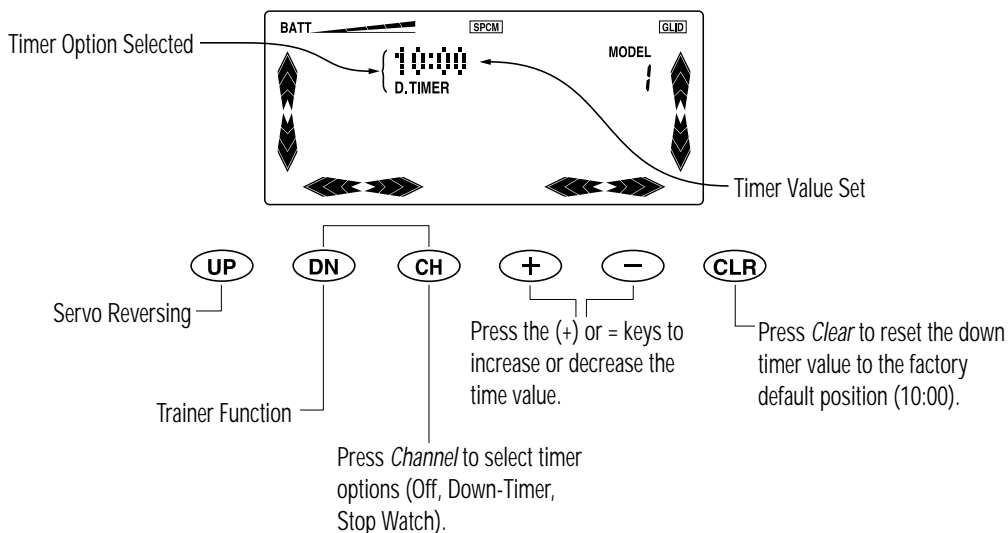

CHAPTER 6: FUNCTIONS (FUNCTION MODE) • Sailplane

Accessing the Timer Functions

Accessing the Timer Functions

1. Place the transmitter switch in the On position.
2. Press the *Down* and *Channel* keys simultaneously to enter the Function mode.
3. Press either the *Up* or *Down* key until "TIMER" is displayed in the left portion of the LCD.
4. Press the *Channel* key to select the desired timer option (Off, Down-Timer, Stop Watch)

Setting the Down-Timer Value

5. Pressing the (+) key will change the display to :10 each time the (+) is pressed, and the value will increase in 10-second intervals up to 59:50 minutes. Pressing the *Clear* key will reset the Countdown Timer to the factory default 10:00 minute value.

When the Down Timer function is selected, the normal display screen will appear as shown below:

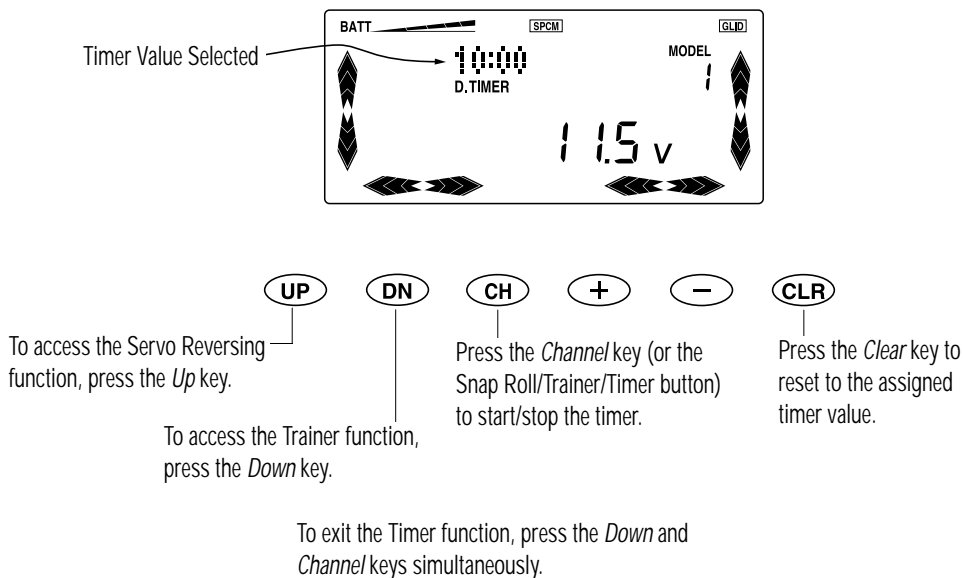

CHAPTER 7: PRACTICAL APPLICATIONS • Sailplane

7.1

X-378 PROGRAM AND MIX APPLICATIONS

This section will outline the procedures and suggested basic mechanical set-up for gliders using a six-servo flight system with each flap and aileron driven by a dedicated servo. The following will be outlined:

- A. Basic Mechanical Setup and Mixing (Aileron Differential and Coupled Aileron-Rudder)
- B. Presets (Launch and Reflex)

- C. Landing Mode Programming
- D. Full Span Variable Camber Mixing
- E. Special Mixes-TE Droop with Elevator up, Reflex with Elevator down and Snap Flaps.

Note: If you are using a 5-servo installation with a single flap servo, all procedures will be similar.

Servo Installation

In preparing your glider wings for servo installation some advance planning will make the setup and programming of the X-378 much easier. The following basic ground rules will speed this process:

1. It is necessary that all wing-mounted servos be installed with the output shaft facing outward toward the wing tips.
2. Before you begin programming it is important to set up the transmitter for multi-function sailplane use. To do this:
 - A.) Turn the transmitter On while you simultaneously hold the *Down* and *Channel* keys to enter the Function mode. Using the *Up* key, move to V.TAIL mix. Use the *Channel* key to move to DUAL (Dual-Flap Mix) and use the (+) key to activate the Dual-Flap function if you are using two flap servos.
 - B.) With the *Up* key, move the display to "LEVRS FLAP" and press the (+) key to change the display to "FL+LS."
 - C.) Press the *Down* and *Channel* keys simultaneously twice to move to the Function mode. Use the *Up* key to move through the functions to the display that reads "TRIM FLAP," L6 (Channel 6). Next, use the (+) key to change the L5 display from "ON" to "OFF." Press the *Channel* key and repeat for L5 (Channel 5). This deactivates the channel 5 gear switch, as well as the channel 6 flap lever to eliminate any inadvertent changes to the flap and aileron position.
3. Use the *Up* key to move the display to "REV." (Servo reversing). Check movement of all servos and adjust servo direction for all surfaces.

4. Use the *Up* key again to move to the SUB-TRIM function. With the *Channel* key, move to FLAP and AUX 2 and adjust in the direction that moves the servo arms so that they raise the flaps. (Suggested values: FLAP UP-90; AUX 2-90)
5. With all trims in neutral, the aileron servo arms should angle forward 20-30 degrees (see illustration at right). This allows for more up throw mechanically. The flap servo arms should be angled slightly to the rear or vertical (see illustration at right). These setups should be the same on each wing as symmetry here helps in programming the landing mode and camber (which will be explained later).
6. In setting up the aileron differential, it is best to use the end-point adjustment in the TRAVL (Travel Adjust) program. 3 or 4:1 differential is generally used on most aileron-equipped gliders. Many pilots will program as much up-aileron as possible and 1/8" to 1/4" down-aileron as a starting point.
7. The X-378 has the aileron/rudder coupling mix preprogrammed in the Function mode menu. No values are set in this program. Use the *Up* key to move through the Function Setting modes to AILE-RUDD mix. Use the *Channel* key to move to the mix switch assignment for the Aileron- to-Rudder Mix. If you want aileron/rudder coupling at all times, use the (+) key to move the display to "ON". To turn this mix off for aerobatics etc., move the display to MIX. This will allow you to use the mix switch located at the right, top-rear of the transmitter to turn the aileron/rudder coupling on and off.



CHAPTER 7: PRACTICAL APPLICATIONS • Sailplane

Servo Installation (continued)

8. To set the amount of coupling, use the *Channel* key to move the display back to the "AILE-RUDD" screen. Hold the aileron stick to one direction and, with the (+) or (-) key, adjust the value on the display to the desired amount of rudder movement in the proper direction.

In the initial setup of your X-378 transmitter (System mode), if you set the flap control preference to FL+LS (Flap Mix switch + Flap Lever for Trim), the setup of your Launch (and Reflex) presets is partially done for you.

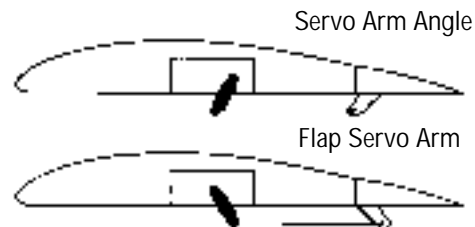

Launch Preset

1. Pull the preset switch down to the launch preset position. This will drop the flaps down further than ideal for most launch situations. Move to the TRAVL (Travel adjustment) portion of your Function mode settings, and with the *Channel* key, move to the flap channel. Reduce the value shown on the display until you get the amount of flap throw desired for launch. You need only adjust the flap channel (Aux 1) as the AUX 2 channel should follow automatically in Dual-Flap mode. This change in value should not affect the flap throw in Crow or Camber mode either.
2. Aileron/camber (Crow) should automatically be mixed into this launch preset if you have chosen the FLP-D switch for the flap/aileron mix. You may have to fine tune the aileron down throws.
3. If you wish to add some elevator up-trim to your launch preset, use the *Up* key to move to FLAP-ELEV

- mix. Use the *Channel* key to move to the switch selection function, and then press the (+) or (-) keys to select F-U/D. Press the *Channel* key twice to move to the mix value display and add the desired amount of up elevator for launch preset. Leave the offset for this mix at 0.
4. To add a high rate aileron/rudder mix to the launch preset, use the *Up* key and move to AILE-RUDD Mix. Next, use the *Channel* key to move the display to the switch selection screen (SW). Use the *Up* key to select FLP-D. Move the flap switch to the down position, and press the *Channel* key once to move to the mix value display. The value will have to be set for both left and right movement of the aileron stick. Set the value at (+)30% to start. Leave the offset for this mix at 0.



CHAPTER 7: PRACTICAL APPLICATIONS • Sailplane

Trailing Edge Reflex Preset

The preset for Trailing Edge Reflex does not require the use of the programmable mixes in the X-378 if you are using the FL+LS function for your flaps (System Mode).

1. Position the flap switch in the reflex (up) position. This will make the flaps raise. Move to the TRAVL (Travel adjustment) portion of the Function Settings mode and adjust the flap up travel to the desired amount of reflex.
2. To set the ailerons for reflex, use the *Up* key to move to the FLAP-AILE mix display. Use the *Channel* key to move to switch select and set to F-U/D. Move to mix value with the *Channel* key and adjust the value to raise ailerons to match flaps. You may have to fine tune by adjusting the aileron travel through the Travel Adjust (endpoint adjustment) function to achieve a straight line along the entire trailing edge.

3. If you wish to automatically adjust elevator trim in the reflex preset, press the *Down* key to move to the FLAP-ELEV mix. Make sure the switch select for this mix is also F-U/D and adjust the elevator trim to the desired amount. (Generally, a slight amount of down is used for better penetration or increased speed). Leave the offset for this mix at 0.

4. To automatically adjust your aileron/rudder mix with the reflex preset (in many cases you may reduce the amount of mix), use the *Up* key to move to AILE-RUDD mix. Press the *Channel* key to move the display to the mix switch selection. Use the *Up* key to select FLP-U. Move the flap switch to the up position. Use the *Channel* key to move to the mix value display. The value will have to be set for both left and right movement of the aileron stick and will be a negative value. Set the mix value for each direction at -10% to start. Leave the offset for this mix at 0.

Snap Flaps

Snap Flaps is a function that mixes a given amount of down flaps when a specified up elevator is given. This aids in tight turns and can be handy when circling in tight thermals or for changing directions quickly. Select an unused programmable mix and mix the elevator channel (ELEV) to the flap channel (FLAP). Pull the elevator stick back to about 75% of its travel and store an offset in this position.

Now pull the elevator stick full back and store a mix value to droop the flaps to the position you desire. Choose the switch position you want to turn off/on the mix. Many pilots choose to leave this function on at all times. Programmable mix 1 or 2 works well for this.

For gliders using flaps for glide path control, the following information will allow you to program the X-378 for precise spot landings and safe descent from high altitude. All of the options and mix requirements for glide path control using flaps are incorporated into one portion of the software. For both landings

and variable trailing edge crow (camber), you will use SPOI-ELEV, which is part of the Function mode. There are actually two modes (or setups) available. These are determined by the position of what is called the crow/camber (GEAR) mix switch (more properly the landing/camber switch), which is located at the left, top corner of the transmitter. Landing position for this switch will be toward the rear of the transmitter (POS.1 in your display). Using the SPOI-ELEV will allow you to operate your flaps with crow (ailerons rising up as spoilerons, if you want), with automatic electronic elevator compensation all from the left stick (Mode II).

This function can operate at neutral flap with the left stick either up or down. However, the trim operates only with the stick at the bottom position. So, if you want to use the trim tab, neutral flap should be with the left stick down. The digital trim lever should stay in the center (neutral) position. The X-378's Digital Trim has a very noticeable audible beep at center that is very easy to locate while flying.



CHAPTER 7: PRACTICAL APPLICATIONS • Sailplane

Snap Flaps (continued)

1. In the Function mode, use the *Up* key until the display reads "SPOI-ELEV." Now press the *Channel* key until "OFFSET" is displayed in the center of the LCD. With the trim tab centered and the left stick in position for neutral flap, press the Clear key to the right of the data keys. This stores your offset or neutral point.

2. Use the *Channel* key and go to SPOI-FLAP. Using the (+) or (-) keys, program the mix value to give 90 degrees of flap throw. It may be necessary to return to the TRAVL (travel adjustment) to fine tune the flap throws and keep both surfaces even as they are lowered.

3. Use the *Channel* key to move to SPOI-ELEV where you can now set your elevator compensation. The value may vary depending on the size and type of elevator used. A starting point for all flying stabilizers will be approximately 35% down; a fixed stabilizer with elevator will generally use a smaller percentage.

4. If you want to add crow (spoilerons), use the *Channel* key to move to SPOI-AILE. With the (+) or (-) keys, set the mix value for the desired amount of up aileron (crow). This is an option that not all pilots will use, but it can be a very effective tool in helping to slow down for landing. Depending on the design of glider you are flying, anywhere from 5-45 degrees of crow (camber) can be useful. This basic setup will provide you with an effective landing mode for almost all conditions. The given values are only guidelines, and you will need to experiment and adjust them to your individual needs and style.

The Full Span/Variable Crow/Camber function also uses the SPOI- portion of the Function mode. The purpose of this function is to allow the varying of the crow (camber) or position of the trailing edge of your wings' airfoil while flying, combined with the ability to

adjust to variable flying conditions. To use this function, place the crow/camber (GEAR) switch in the forward (0) position.

1. Use the *Channel* key to move the display to "SPOI-FLAP," switch position 0.

2. With the left stick moved to the full throw (down flap) position, adjust the mix value for approximately 1/4" to 3/8" down flap.

2. Leave the left stick in that position and use the *Channel* key to move to SPOI-AILE, switch position 0. Use the (+) or (-) keys to move the ailerons down the same amount as the flaps. You may have to fine tune each aileron in the Travel Adjustment function (TRAVL) to get a straight line along the trailing edge.

3. If you want to change elevator trim as you add crow (camber), you can assign a value in SPOI-ELEV, switch position 0 for this purpose.

4. If you have set the camber and the landing modes at neutral with the left stick in the lower position where the trim tab will function, the trailing edge will reflex (move up) 2-3 degrees (in camber mode only) when the trim tab is moved down. For most modern glider airfoils, this is adequate for increased speed or penetration in wind.

The open programmable mixes available in the X-378 allow you to enhance your presets with a variety of mix applications. Another programming feature included in the X-378 is the ability to assign a switch to use for the following mixes: All programmable mixes, Elevator-Flapperons, Aileron-Flapperons, Flapperons-Elevator, and Flapperons-Aileron. In addition, the latter two mixes also include a trim offset for the flap.



CHAPTER 7: PRACTICAL APPLICATIONS • Sailplane

Flapperons

Following are guidelines for mixing flaps to follow aileron movement. This mix will work as part of the Launch and/or reflex presets at your option. The X-378 transmitter must have the Dual-Flaps activated in the Function mode to access the aileron/flap mix.

Aileron/Flap Mix

1. In the Function mode, use the *Up* key to move to the AILE-FLAP function. Now with the *Channel* key, move to the switch select to select your switch option.
2. Move to mix value with the *Channel* key and enter the value for throw. There is no separate mix value for each direction. There is no offset used with this mix.

Elevator/Flap Mix

The Elevator/Flap Mix is another optional mix that can be used as an option with either preset or other switch options. Different mix values are programmed for up and down elevator throw. This mix is generally used with slope aerobatics, or for multi-task speed and distance tasks.

1. From the aileron/flap mix, use the *Down* key to move to ELEV-FLAP function. Now press the *Channel* key to move to switch select. In many multi-task applications this mix will be used with reflex (FLP-U).
2. Press the *Channel* key to move back to mix value and enter for desired direction and throw. The most common is to drop the wing trailing edge with up elevator.



CHAPTER 8 : DATA SHEET • Sailplane

X-378 DATA SHEET **GLID**

MODEL NO _____

MODEL NAME _____

MODULATION SPCM · PPM · EPCM

	THRO	AILE	ELEV	RUDD	GRAB	FLAP	AJDR
REVERSE SW	NORM REV	NORM REV	NORM REV	NORM REV	NORM REV	NORM REV	NORM REV
SUB TRIM							
TRAVEL ADJUST	+ %	L %	D %	L %	L %	U %	+ %
	- %	R %	U %	R %	R %	D %	- %
FAIL SAFE (SPCM):							

DUAL RATE EXP	0	DIR	%	%	%
		EXP	%	%	%
	1	DIR	%	%	%
		EXP	%	%	%
ADT					

ELEV-FLAP MOD	DOWN	%
	UP	%
	SW	

AIR-FLAP MOD	RATE	%
	SW	

DIFFEREN	%
----------	---

FLAP-ELEV MOD	UP	%
	DOWN	%
	SW	

Wingtip MIX	0	-ELEV	%
		-AILE	%
		-FLAP	%
	1	-ELEV	%
		-AILE	%
		-FLAP	%
SPOILER G/rev			

FLAP-AILE MOD	RATE	%
	SW	
FLAP OFFSET		

AILE-RUDD MOD	RATE	%
	SW	

Wing Type	V-TAIL	ON-OFF
	DUAL FLAP	ON-OFF

DUAL FLAP TRIM	
LEVRS	ON-OFF
LEVRS	ON-OFF

INPUT SET: FLAP INI	LEVRS · FL+LS
---------------------	---------------

PROGRAM MOD	CHANNEL	SW	+POS	-POS	OFFSET
	MOD1	-		%	%
	MOD2	-		%	%
	MOD3	-		%	%
	MOD4	-		%	%
	MOD5	-		%	%



SECTION V: IMPORTANT INFORMATION

1

SERVO PRECAUTIONS

- Do not lubricate servo gears or motors.
- Do not overload retract servos during retracted or extended conditions. Make sure they are allowed to travel their full deflection. Overloading or stalling the retract servo can cause excessive current drain.
- Make sure that all servos move freely through their rotations and that no linkages hang up or bind. A binding control linkage can cause a servo to draw excessive current. A stalled servo can drain a battery pack in a matter of minutes.
- Correct any control surface "buzz" or "flutter" as soon as it is noticed in flight, as this condition can destroy the feedback potentiometer in the servo. It may be extremely dangerous to ignore such "buzz" or "flutter."
- Use the supplied rubber grommets and brass servo eyelets when mounting your servos. Do not over-tighten the servo mounting screws, as this negates the dampening effect of the rubber grommets.
- Ensure that the servo horn is securely fastened to the servo. Use only the JR servo arm screws provided; the thread size is different from that used by other manufacturers.
- Do not continue to use the servo arms when they become "yellowed" or discolored. Such servo arms may be brittle and can snap at any time, possibly causing the aircraft to crash.
- Check all related mounting screws and linkages frequently. Aircraft often vibrate, causing linkages and screws to loosen.

2

GENERAL NOTES

Radio controlled models are a great source of pleasure. Unfortunately, they can also pose a potential hazard if not maintained and operated properly. It is imperative that you install your radio control system correctly. Additionally, your level of piloting competency must be high enough to ensure that you are able to control your aircraft under all conditions. If you are a newcomer to radio controlled flying, please seek help from an experienced pilot or your local hobby shop.

Safety Do's and Don'ts for Pilots

- Ensure that your batteries have been properly charged prior to initial flight.
- Keep track of the time that the system is turned on so that you will have an idea of how long you can safely operate your system.
- Perform a ground range check prior to the initial flight of the day. See the "Daily Flight Checks Section" for information on how to do so.
- Check all control surfaces prior to each takeoff.
- Use frequency flags.
- Do not fly your model near spectators, parking areas or at any other area that could result in injury to people or damage of property.
- Do not fly during adverse weather conditions. Poor visibility can cause disorientation and loss of control of your aircraft. Strong winds can cause similar problems.
- Do not fly unless your frequency is clear.

Warning: Only one transmitter at a time can operate on a given frequency. If you turn on your transmitter while someone else is operating a model on your frequency, both pilots will lose control of their models. Only one person can use a given frequency at a time. It does not matter if it is AM, FM or PCM—only one frequency at a time.

- Do not point the transmitter antenna directly toward the model. The radiation pattern from the tip of the antenna is inherently low.
- Do not take chances. If at any time during flight you observe any erratic or abnormal operation, land immediately and do not resume flight until the cause of the problem has been ascertained and corrected. Safety can never be taken lightly.

3

FEDERAL AVIATION ADMINISTRATION

1. Purpose

This advisory outlines safety standards for operations of model aircraft. We encourage voluntary compliance with these standards.

2. Background

Attention has been drawn to the increase in model aircraft operation. There is a need for added caution when operating free flight and radio controlled craft in order to avoid creating a noise nuisance or a potential hazard to full-scale aircraft and persons and/or property on the surface.

3. Operating Standards

Modelers generally are concerned with safety and exercise good judgment when flying model aircraft. However, in the interest of safer skies, we encourage operators of radio controlled and free flight models to comply with the following standards:

- a. Exercise vigilance in locating full-scale aircraft (get help if possible) so as not to create a collision hazard.
- b. Select an operating site at sufficient distance from populated areas so you do not create a noise problem or a potential hazard.
- c. Do not fly higher than 400 feet above the surface.
- d. Always operate more than three miles from the boundary of an airport unless you are given permission to be closer by the appropriate air traffic control facility in the case of an airport for which a control zone has been designated or by the airport manager in the case of other airports.
- e. Do not hesitate to ask for assistance in complying with these guidelines at the airport traffic control tower or air route traffic control center nearest the site of your proposed operation.

Information Provided By:
Director, Air Traffic Service Federal Aviation
Administration, Washington, D.C.

4

DAILY FLIGHT CHECKS

1. Check the battery voltage on both the transmitter and the receiver battery packs. Do not fly below 9.0V on the transmitter or below 4.7V on the receiver. To do so can crash your aircraft.

Note: When you check these batteries, ensure that you have the polarities correct on your expanded scale voltmeter.

2. Check all hardware (linkages, screws, nuts, and bolts) prior to each day's flight. Be sure that binding does not occur and that all parts are properly secured.

3. Ensure that all surfaces are moving in the proper manner.

4. Perform a ground range check before each day's flying session. The range check should be as follows:

- Do not extend the transmitter antenna at this time. Turn the transmitter "on."
- Turn the model "on."
- Slowly walk away from the model while moving the control surfaces. The aircraft should function properly at a distance of 60-75 feet.

5. Prior to starting your aircraft, turn off your transmitter, then turn it back on. Do this each time you start your aircraft. If any critical switches are on without your knowledge, the transmitter alarm will warn you at this time.

6. Check that all trim levers are in the proper location.

7. All servo pigtails and switch harness plugs should be secured in the receiver. Make sure that the switch harness moves freely in both directions.

5

FREQUENCY CHART

72 MHz requires no special license to operate.

Low Band 72 MHz		High Band 72 MHz	
Ch.No.	Frequency	Ch.No.	Frequency
11	72.010	36	72.510
12	72.030	37	72.530
13	72.050	38	72.550
14	72.070	39	72.570
15	72.090	40	72.590
16	72.110	41	72.610
17	72.130	42	72.630
18	72.150	43	72.650
19	72.170	44	72.670
20	72.190	45	72.690
21	72.210	46	72.710
22	72.230	47	72.730
23	72.250	48	72.750
24	72.270	49	72.770
25	72.290	50	72.790
26	72.310	51	72.810
27	72.330	52	72.830
28	72.350	53	72.850
29	72.370	54	72.870
30	72.390	55	72.890
31	72.410	56	72.910
32	72.430	57	72.930
33	72.450	58	72.950
34	72.470	59	72.970
35	72.490	60	72.990

Transmitter Crystal Replacement Notice:

The Federal Communications Commission (FCC) requires that changes in transmitter frequency must be performed only by an authorized service technician (Horizon Service Center).

Any transmitter frequency changes made by a non-certified technician may result in a violation of FCC rules.

Channels 12-14 are not available through JR.

WARRANTY INFORMATION

Important: Be sure to keep your original dated sales receipt, as you will be required to provide proof-of-purchase date for the equipment to be serviced under warranty.

Warranty Coverage

Your new JR Remote Control Radio System is warranted to the original purchaser against manufacturer defects in material and workmanship for an unprecedented 3 years from the date of purchase. During this period, Horizon Service Center will repair or replace, at our discretion, any component that is found to be factory defective at no cost to the purchaser. This warranty is limited to the original purchaser of the unit and is not transferable.

This warranty does not apply to any unit that has been improperly installed, mishandled, abused or damaged in a crash, or to any unit that has been repaired or altered by any unauthorized agencies. Under no circumstances will the buyer be entitled to consequential or incidental damages. This limited warranty gives you specific legal rights; you also have other rights, which may vary from state to state. As with all fine electronic equipment, do not subject your radio system to extreme temperatures, humidity or moisture. Do not leave it in direct sunlight for long periods of time.

Repair Service Directions

In the event that your JR radio needs service, please follow the instructions listed below.

1. Check all on/off switches to be sure they are off. This will speed the repair process of checking battery condition.
2. Return your system components only (transmitter, receiver, servos, etc.). Do not return your system installed in a model aircraft, car, boat, etc.
3. Preferably, use the original carton/packaging (molded foam container), or equivalent, to ship

your system. Do not use the system carton itself as a shipping carton, you should package the system carton within a sturdy shipping container using additional packing material to safeguard against damage during transit. Include complete name and address information inside the carton, as well as clearly writing it on the outer label/return address area.

4. Include detailed information explaining your operation of the system and problem(s) encountered. Provide an itemized list of equipment enclosed and identify any particular area/function, which may better assist our technicians in addressing your concerns. Within your letter, advise us of the payment method you prefer to use. Horizon Service Center accepts VISA or MasterCard. Please include your card number and expiration date. Date your correspondence, and be sure your complete name and address appear on this enclosure.
5. Include your name, mailing address, and a phone number where you can be reached during the business day.

Warranty Repairs

To receive warranty service, you must include a copy of your original dated sales receipt to verify your proof-of-purchase date. Providing that warranty conditions have been met, your radio will be repaired without charge.

Normal Non-Warranty Repairs

Should your repair cost exceed 50% of the retail purchase cost, you will be provided with an estimate advising you of your options.

Mail your system to:
Horizon Service Center
4105 Fieldstone Road
Champaign, IL 61822
Phone: (217) 355-9511

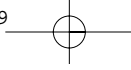

Notes:

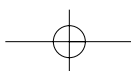
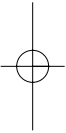
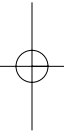

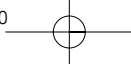

Notes:

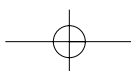
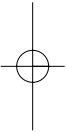
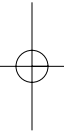

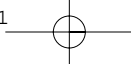

Notes:

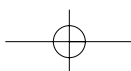
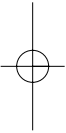
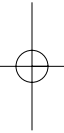

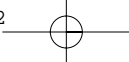

**Horizon Hobby Inc.,
4105 Fieldstone Road
Champaign, IL 61822
www.horizonhobby.com
Phone: (217) 355-9511**

