

Mounting Instructions

Digital Torque Transducer **T12**



A1979-10.0 en



Contents	Page
Safety instructions	5
1 Markings used	9
1.1 Symbols on the transducer and / or Stator	9
1.2 The markings used in this document	10
2 Scope of supply	11
3 Operation	11
4 Application	12
5 Signal flow	13
6 Structure and mode of operation	14
7 Mechanical installation	16
7.1 Important precautions during installation	16
7.2 Conditions on site	17
7.3 Mounting position	17
7.4 Installing the slotted disc (rotational speed measuring system only)	18
7.5 Installing the rotor	19
7.6 Fitting the protection against contact (option)	21
7.7 Installing the stator	27
7.7.1 Preparing with the mounting kit (included among the items supplied)	28
7.7.2 Aligning the stator	30
7.7.3 Stator installation over the protection against contact (option)	32
7.8 Optical rotational speed/angle of rotation measuring system (option)	33
7.8.1 Axial alignment	33
7.8.2 Radial alignment	34
8 LED status display	36
8.1 Measuring mode operation	36
8.2 Rotor clearance setting mode operation	36
8.3 Rotational speed measuring system setting mode operation ...	36
9 Electrical connection	37
9.1 General information	37
9.2 Shielding design	39

9.3	Connector pin assignment	39
9.4	Supply voltage	43
10	Shunt signal	45
11	Load-carrying capacity	46
12	TEDS	47
13	Maintenance	54
14	Waste disposal and environmental protection	55
15	Specifications	56
15.1	Nominal (rated) torque 100 N·m to 1 kN·m	56
15.2	Nominal (rated) torque 2 kN·m to 10 kN·m	63
16	Dimensions	70
16.1	Rotor 100 N·m to 200 N·m	70
16.2	Rotor 500 N·m to 10 kN·m	71
16.3	Stator 100 N·m to 200 N·m with rot.speed meas. system	72
16.4	Stator 100 N·m to 200 N·m with rot. speed meas. system	73
16.5	Stator 100 N·m to 10 kN·m with rot. speed meas. system	74
16.6	Stator 100 N·m to 200 N·m with prot. against contact	75
16.7	Stator 100 N·m to 200 N·m with prot. against contact	76
16.8	Stator 500 N·m to 1 kN·m with prot. against contact	77
16.9	Stator 2 kN·m to 10 kN·m with prot. against contact	78
16.9.1	Protection against contact plates 100 N·m to 200 N·m ...	79
16.9.2	Protection against contact plates 500 N·m to 10 kN·m ...	79
16.10	Mounting dimensions	80
17	Supplementary technical information	81
18	Condition at the time of delivery	82
19	Ordering numbers	87
20	Accessories	88

Safety instructions

FCC Compliance & Advisory Statement for Option 7, Code U

This device complies with Part 15 of the FCC Rules. Operation is subject to the following two conditions: (1) this device may not cause harmful interference, and (2) this device must accept any interference received, including interference that may cause undesired operation.

The FCC identifier or the unique identifier, as appropriate, must be displayed on the device.

Model	FCC ID	IC
T12, 100 Nm, 200 Nm	2ADAT-T12S2	12438A-T12S2
T12, 500 Nm, 1 kNm	2ADAT-T12S3	12438A-T12S3
T12, 2 kNm, 3 kNm	2ADAT-T12S4	12438A-T12S4
T12, 5 kNm	2ADAT-T12S5	12438A-T12S5
T12, 10 kNm	2ADAT-T12S6	12438A-T12S6

The FCC ID number in dependence of measuring range: label example only on the Stator FCC ID and IC number range.

Label example with FCC ID and IC number. Location on the stator of the device.

<p>FCC ID: 2ADAT-T12S2 IC: 12438A-T12S2 This device complies with part 15 of the FCC Rules. Operation is subject to the following two conditions: (1) This device may not cause harmful interference, and (2) this device must accept any interference received, including interference that may cause undesired operation.</p>

Fig 1.1: Example of the label

Industry Canada for Option 7, Code U

IC: 12483A-T12S2

This device complies with Industry Canada standard RSS210.

This device complies with Industry Canada license-exempt RSS standard(s). Operation is subject to the following two conditions: (1) this device may not cause interference, and (2) this device must accept any interference, including interference that may cause undesired operation of the device.

Cet appareil est conforme aux norme RSS210 d'Industrie Canada.

Cet appareil est conforme aux normes d'exemption de licence RSS d'Industry Canada. Son fonctionnement est soumis aux deux conditions suivantes : (1) cet appareil ne doit pas causer d'interférence et (2) cet appareil doit accepter toute interférence, notamment les interférences qui peuvent affecter son fonctionnement.

NOTE

Any changes or modification not expressly approved by the party responsible for compliance could void the user's authority to operate the device. Where specified additional components or accessories elsewhere defined to be used with the installation of the product, they must be used in order to ensure compliance with FCC regulations.

Appropriate use

The T12 torque flange is used exclusively for torque, angle of rotation and power measurement tasks within the load limits stipulated in the specifications. Any other use is not appropriate.

Stator operation is only permitted when the rotor is installed.

The torque flange may only be installed by qualified personnel in compliance with the specifications and with the safety requirements and regulations of these mounting instructions. It is also essential to observe the applicable legal and safety regulations for the application concerned. The same applies to the use of accessories.

The torque flange is not intended for use as a safety component. Please also refer to the "Additional safety precautions" section. Proper and safe operation requires proper transportation, correct storage, siting and mounting, and careful operation.

Load carrying capacity limits

The data in the technical data sheets must be complied with when using the torque flange. In particular, the respective maximum loads specified must never be exceeded. For example, the values stated in the specifications must not be exceeded for

- limit torque,
- longitudinal limit force, lateral limit force or limit bending moment,
- torque oscillation width,
- breaking torque,
- temperature limits,
- the limits of the electrical load-carrying capacity.

Use as a machine element

The torque flange can be used as a machine element. When used in this manner, it must be noted that, to favor greater sensitivity, the transducer is not designed with the safety factors usual in mechanical engineering. Please refer here to the section “Load carrying capacity limits” and to the specifications.

Accident prevention

According to the prevailing accident prevention regulations, once the transducers have been mounted, a covering agent or cladding has to be fitted as follows:

- The covering agent or cladding must not be free to rotate.
- The covering agent or cladding should prevent squeezing or shearing and provide protection against parts that might come loose.
- Covering agents and cladding must be positioned at a suitable distance or be so arranged that there is no access to any moving parts within.
- Covering agents and cladding must still be attached, even if the moving parts of the torque flange are installed outside people’s movement and working range.

The only permitted exceptions to the above requirements are if the torque flange is already fully protected by the design of the machine or by existing safety precautions.

Additional safety precautions

The torque flange cannot (as a passive transducer) implement any (safety-relevant) cutoffs. This requires additional components and constructive measures, for which the installer and operator of the plant is responsible. The electronics conditioning the measurement signal should be designed so that measurement signal failure does not subsequently cause damage.

The scope of supply and performance of the transducer covers only a small area of torque measurement technology. In addition, equipment planners, installers and operators should plan, implement and respond to safety engineering considerations in such a way as to minimize residual dangers. Pertinent national and local regulations must be complied with.

General dangers of failing to follow the safety instructions

The torque flange corresponds to the state of the art and is reliable. Transducers can give rise to residual dangers if they are incorrectly operated or inappropriately mounted, installed and operated by untrained personnel. Every person involved with siting, starting-up, operating or repairing a torque flange must have read and understood the mounting instructions and in particular the technical safety instructions. The transducers can be damaged

or destroyed by non-designated use of the transducer or by non-compliance with the mounting and operating instructions, these safety instructions or any other applicable safety regulations (BG safety and accident prevention regulations), when using the transducers. Transducers can break, particularly in the case of overloading. The breakage of a transducer can also cause damage to property or injury to persons in the vicinity of the transducer.

If the torque flange is not used according to the designated use, or if the safety instructions or specifications in the mounting and operating instructions are ignored, it is also possible that the transducer may fail or malfunction, with the result that persons or property may be adversely affected (due to the torques acting on or being monitored by the torque flange).

Conversions and modifications

The transducer must not be modified from the design or safety engineering point of view except with our express agreement. Any modification shall exclude all liability on our part for any damage resulting therefrom.

Selling on

If the torque flange is sold on, these mounting instructions must be included with the torque flange.

Qualified personnel

Qualified personnel means persons entrusted with siting, mounting, starting up and operating the product, who possess the appropriate qualifications for their function.

This includes people who meet at least one of the three following requirements:

- Knowledge of the safety concepts of automation technology is a requirement and as project personnel, you must be familiar with these concepts.
- As automation plant operating personnel, you have been instructed how to handle the machinery. You are familiar with the operation of the equipment and technologies described in this documentation.
- As system startup engineers or service engineers, you have successfully completed the training to qualify you to repair the automation systems. You are also authorized to ground and label circuits and equipment and place them in operation in accordance with safety engineering standards.

1 Markings used

1.1 Symbols on the transducer and / or Stator



Meaning: **Read and note the data in this manual**



Meaning: **CE mark**

The CE mark enables the manufacturer to guarantee that the product complies with the requirements of the relevant EC directives (the Declaration of Conformity can be found on the HBM website at www.hbm.com under HBMdoc).

Lable example with FCC ID and IC number. Location on the stator of the device.

FCC ID: 2ADAT-T12S2

IC: 12438A-T12S2

This device complies with part 15 of the FCC Rules. Operation is subject to the following two conditions: (1) This device may not cause harmful interference, and (2) this device must accept any interference received, including interference that may cause undesired operation.

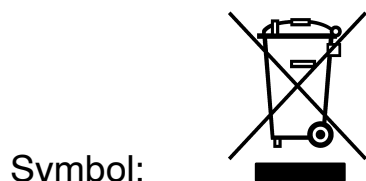







Meaning: **Statutory waste disposal mark**

The electrical and electronic devices that bear this symbol are subject to the European waste electrical and electronic equipment directive 2002/96/EC. The symbol indicates that, in accordance with national and local environmental protection and material recovery and recycling regulations, old devices that can no longer be used must be disposed of separately and not with normal household garbage, see also Chapter 14, page 55.

1.2 The markings used in this document

Important instructions for your safety are specifically identified. It is essential to follow these instructions in order to prevent accidents and damage to property.

Symbol	Significance
 WARNING	This marking warns of a <i>potentially</i> dangerous situation in which failure to comply with safety requirements <i>can</i> result in death or serious physical injury.
 CAUTION	This marking warns of a <i>potentially</i> dangerous situation in which failure to comply with safety requirements <i>can</i> result in slight or moderate physical injury.
 NOTE	This marking draws your attention to a situation in which failure to comply with safety requirements <i>can</i> lead to damage to property.
 Important	This marking draws your attention to <i>important</i> information about the product or about handling the product.
 Tip	This marking indicates application tips or other information that is useful to you.
	This marking draws your attention to information about the product or about handling the product.
<i>Emphasis</i>	Italics are used to emphasize and highlight texts.

2 Scope of supply

- Digital torque transducer (rotor and stator)
- T12 mounting instructions
- T12 system CD
- Mounting kit
- Manufacturing certificate
- Tape wound core (toroidal core) only with Option 9, Code U
- Tape wound core (toroidal core) only with Option 9, Code U
- Optional:
 - A rotational speed measuring system, comprising an optical rotational speed sensor and a rotational speed kit (slotted disc, screwdriver, threadlocker, screws)
 - Protection against contact
 - A mounted coupling

3 Operation

The supplied T12 system CD contains the “T12 Assistant” control software. You can use this software to:

- monitor the correct installation of the torque transducer
- set the signal conditioning (zero balance, filters, scaling)
- protect your settings or load the factory settings
- display and evaluate the measured values

Instructions for installing the T12 Assistant on your PC can be found in the “T12 Assistant Control Software” Quick Start Guide (pdf file on the T12 System CD and included in the “Setup Toolkit for T12” accessory).

Instructions for operating the T12 Assistant can be found in the program’s online Help, which is called with function key F1 or via the menu bar.

Instructions for connecting to fieldbus systems can be found in the “T12 CAN Bus/PROFIBUS” operating manual (pdf file on the T12 system CD).

4 Application

The T12 digital torque transducer acquires static and dynamic torque at stationary or rotating shafts, determines the rotational speed or angle of rotation while specifying the direction of rotation, and calculates the power. It is designed for:

- highly dynamic torque measurements when testing the power and functionality of engines and compound sets
- high-resolution rotational speed and angle of rotation measurements
- fast, dynamic power measurements on engine and transmission test rigs and roll test stands

Designed to work without bearings and with contactless digital signal transmission, the torque measuring system is maintenance-free.

The torque transducer is supplied for nominal (rated) torques of 100 N·m to 10 kN·m. Depending on the nominal (rated) torque, maximum rotational speeds of up to 18 000 rpm are permissible.

The T12 torque transducer is reliably protected against electromagnetic interference. It has been tested according to harmonized European standards and complies with US and Canadian standards. The product carries the CE mark and / or FCC label.

5 Signal flow

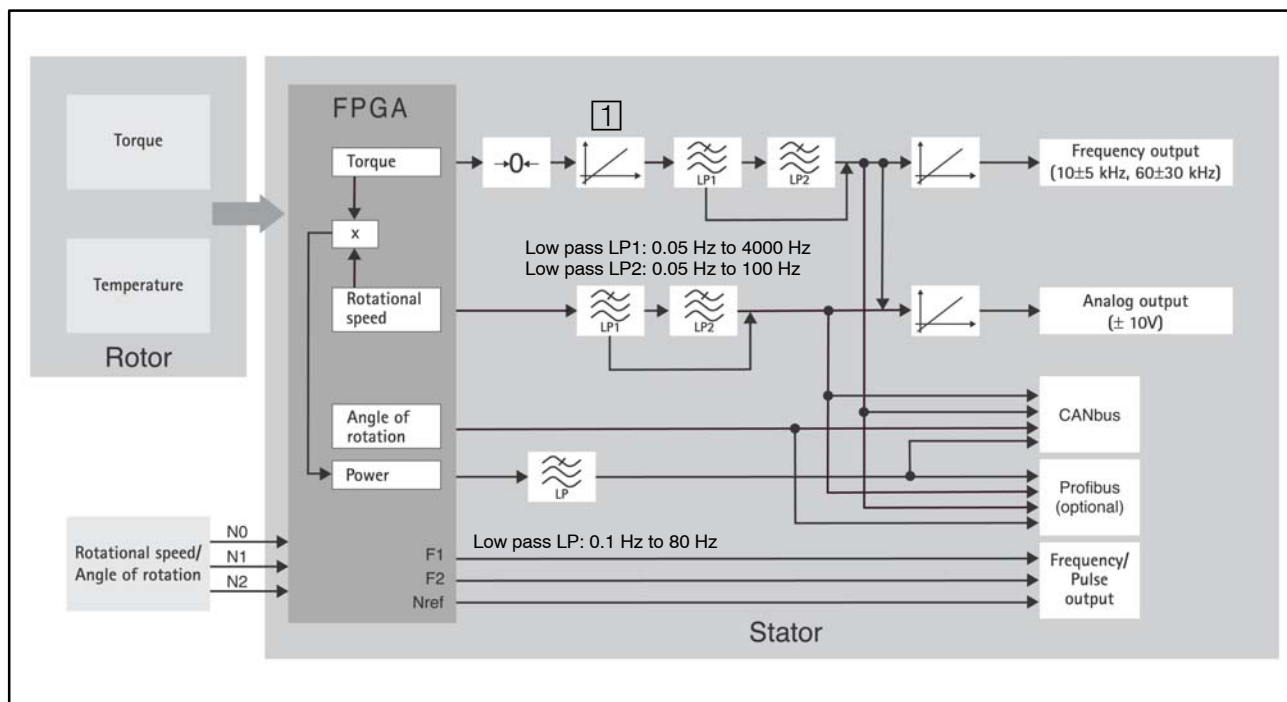

Fig. 4.1: Signal flow diagram

The torque and the temperature signal are already digitized in the rotor and transmission is noise-free.

The torque signal can be zeroed $\rightarrow 0 \leftarrow$, scaled $\swarrow \nearrow$ (2-point scaling) and filtered via two low passes (LP1 and LP2). A further scaling of the frequency output and the analog output is then possible.



Important

Scaling at position $\boxed{1}$ (see Fig. 4.1) changes the internal calibration of the torque transducer.

The rotational speed signal can be filtered and also scaled for analog output. The angle of rotation signal, the power signal (low-pass filter LP) and the temperature signal are only available on fieldbuses.

The torque signal and the rotational speed signal can be filtered via two low passes connected in series, with filter outputs also being available separately. The scaled, unfiltered torque signal is used to calculate power. The resultant, highly-dynamically calculated power signal is filtered via a further low pass.

For settings over 100 Hz (torque low-pass filter 1 only), phase delay compensation is run for the angle of rotation signal. This ensures that torque and angle of rotation values that are measured simultaneously are also output simultaneously.

Two pulse strings, offset by 90°, are also available as RS422-compatible signals for rotational speed and angle of rotation.

6 Structure and mode of operation

The torque transducer comprises two separate parts: the rotor and the stator. Strain gages (SGs) are installed on the rotor for torque calculation. Carrier-frequency technology (19.2 kHz carrier frequency) is used for the SG evaluation. The rotor temperature is acquired at two measuring points and averaged.

The electronics for transmitting the bridge excitation voltage and the measurement signal are located centrally in the rotor. The coils for the contactless transmission of excitation voltage and measurement signal are located on the outer circumference of rotor side A. The signals are sent and received by a transmitter head. The transmitter head is mounted on the stator, which houses the electronics for voltage adaptation and signal conditioning. Connector plugs for inputs and outputs (for pin assignment, see Chapter 9.3) are located on the stator. The transmitter head encloses the rotor over a segment of about 120° and should be mounted concentrically around the rotor (see Chapter 7).

In the case of the rotational speed measuring system option, the rotational speed sensor is mounted on the stator and the customer attaches the associated slotted disc on the rotor. Rotational speed measurement is optical, using the infrared transmitted light principle.

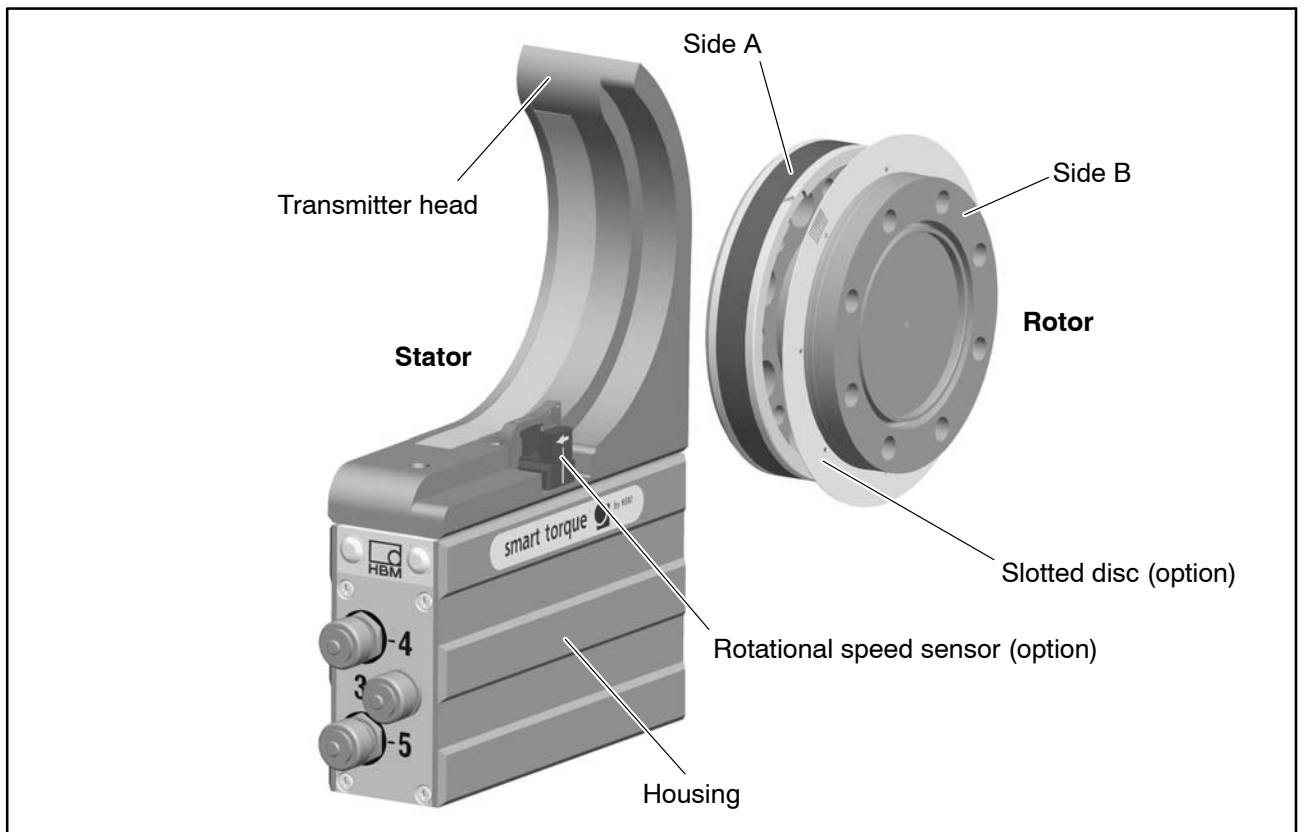

Fig. 5.1: Mechanical structure, exploded view

7 Mechanical installation

7.1 Important precautions during installation

NOTE

A torque flange is a precision measuring element and therefore needs careful handling. Dropping or knocking the transducer may cause permanent damage. Make sure that the transducer cannot be overloaded, including while it is being mounted.

- Handle the transducer with care.
- Check the effect of bending moments, critical rotational speeds and natural torsional vibrations, to prevent the transducer being overloaded by resonance sharpness.
- Make sure that the transducer cannot be overloaded.

WARNING

There is a danger of the transducer breaking if it is overloaded. This can cause danger for the operating personnel of the system in which the transducer is installed.

Implement appropriate safety measures to avoid overloads and to protect against resulting dangers.

- Use a threadlocker (medium strength, e.g. LOCTITE) to glue the screws into the counter thread to exclude prestressing loss due to screw slackening, in the event of alternating loads.
- Comply with the mounting dimensions to enable correct operation.

An appropriate shaft flange enables the T12 torque flange to be mounted directly. It is also possible to mount a joint shaft or relevant compensating element directly on the rotor (using an intermediate flange when required). Under no circumstances should the permissible limits specified for bending moments, lateral and longitudinal forces be exceeded. Due to the T12 torque flange's high torsional stiffness, dynamic shaft train changes are kept to a minimum.



Important

Even if the unit is installed correctly, the zero point adjustment made at the factory can shift by up to approx. 3% of the sensitivity. If this value is exceeded, we advise you to check the mounting conditions. If the residual zero offset when the unit is removed is greater than 1% of the sensitivity, please send the transducer back to the Darmstadt factory for testing.

7.2 Conditions on site

The T12 torque transducer is protected to IP54 according to EN 60529. Protect the transducer from coarse dirt, dust, oil, solvents and moisture. During operation, the prevailing safety regulations for the security of personnel must be observed (see “Safety instructions”).

There is wide ranging compensation for the effects of temperature on the output and zero signals of the T12 torque transducer (see specifications on page 56). This compensation is carried out at static temperatures. This guarantees that the circumstances can be reproduced and the properties of the transducer can be reconstructed at any time.

If there are no static temperature ratios, for example, because of the temperature differences between flange A and flange B, the values given in the specifications can be exceeded. Then for accurate measurements, you must ensure static temperature ratios by cooling or heating, depending on the application. As an alternative, check thermal decoupling, by means of heat radiating elements such as multiple disc couplings.

7.3 Mounting position

The transducer can be mounted in any position. With clockwise torque, the output frequency is 10 to 15 kHz (Option 4, code DF1/DU2: 60 kHz to 90 kHz). In conjunction with HBM amplifiers or when using the voltage output, a positive output signal (0 V to +10 V) is present.

With counterclockwise torque, the output frequency is 5 kHz to 10 kHz (Option 4, code DF1/DU2: 30 kHz to 60 kHz).

In the case of the rotational speed measuring system, an arrow is attached to the head of the sensor to clearly define the direction of rotation. When the transducer rotates in the direction of the arrow, a positive rotational speed signal is output.

7.4 Installing the slotted disc (rotational speed measuring system only)

To prevent damage to the rotational speed measuring system's slotted disc during transportation, it is not mounted on the rotor. The customer must attach it to the mounting ring before installing the rotor in the shaft train. The mounting ring and the associated rotational speed sensor are already mounted at the factory.

The requisite screws, a suitable screwdriver and the threadlocker are included among the components supplied.

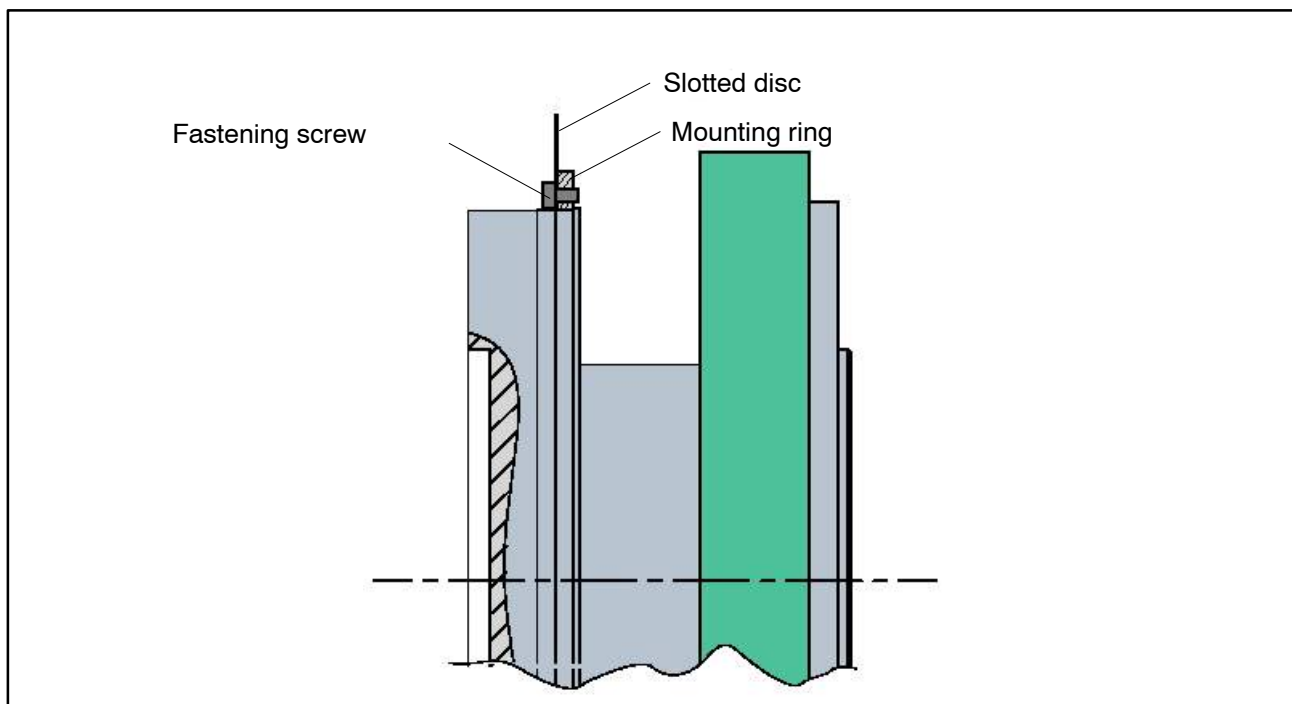

Fig. 6.1: Installing the slotted disc



Important

When carrying out the installation, be careful not to damage the slotted disc!

Installation sequence

1. Push the slotted disc onto the mounting ring and align the screw holes.
2. Apply some of the threadlocker to the screw thread and tighten the screws (tightening torque < 0.15 N·m).

7.5 Installing the rotor

Tip

Usually the rotor type plate is no longer visible after installation. This is why we include with the rotor additional stickers with the important characteristics, which you can attach to the stator or any other relevant test-bench components. You can then refer to them whenever there is anything you wish to know, such as the shunt signal. To explicitly assign the data, the identification number and the size are engraved on the rotor flange, where they can be seen from outside.

NOTE

Make sure during installation that you do not damage the measuring zone marked in Fig. 6.2 by using it to support tools, or knocking tools against it when tightening screws, for example. This can damage the transducer and produce measurement errors, or even destroy the transducer.

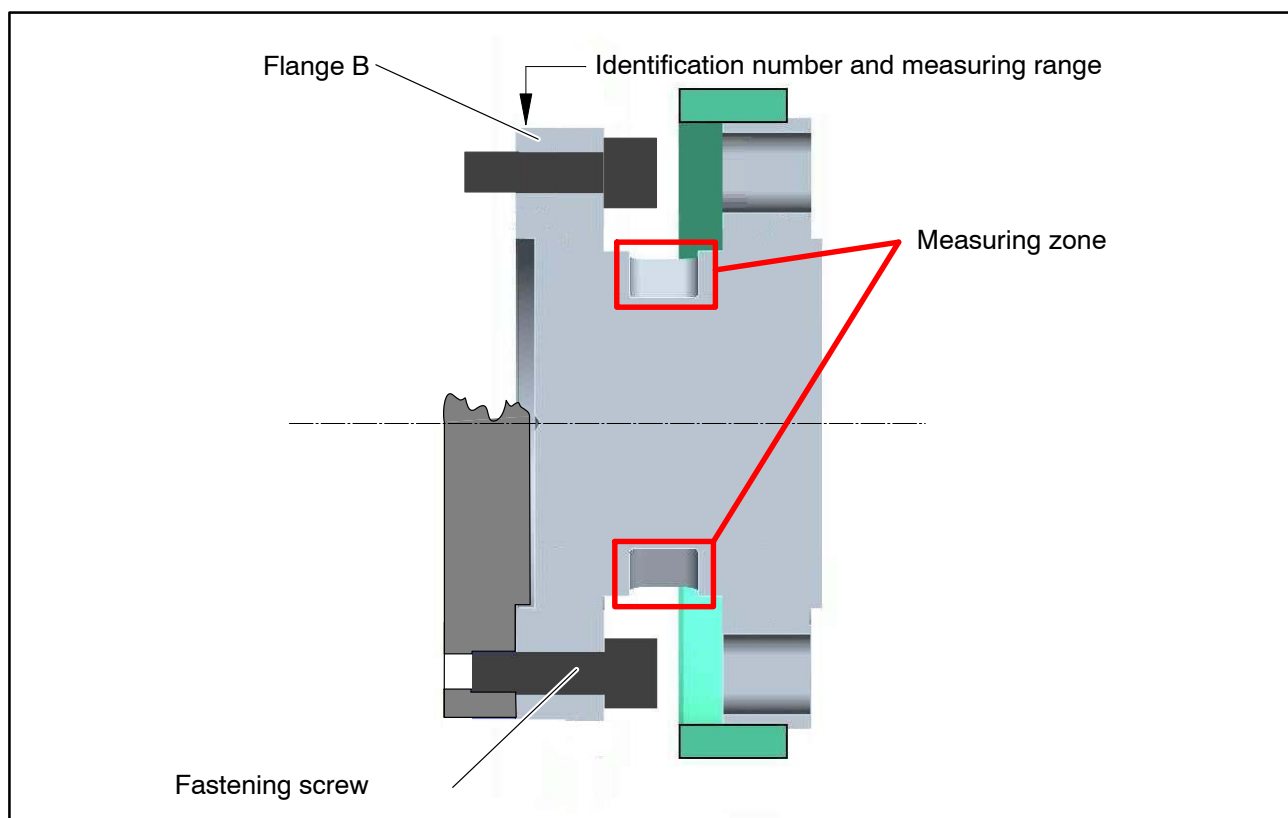

Fig. 6.2: Screw connections, flange B

1. Prior to installation, clean the plane faces of the transducer flange and the counter flange.
For safe torque transfer, the faces must be clean and free from grease. Use a piece of cloth or paper soaked in solvent. When cleaning, make sure that you do not damage the transmitter coils.
2. For the flange B screw connection, use hexagon socket screws **DIN EN ISO 4762 of property class 10.9** (measuring ranges 3 kN·m to 10 kN·m: 12.9) of the appropriate length (depending on the connection geometry, see Table 6.1).
We recommend fillister-head screws DIN EN ISO 4762, blackened, smooth-headed, permitted size and shape variance as per DIN ISO 4759, Part 1, product class A.
3. First tighten all the screws crosswise with 80% of the prescribed tightening torque (Table 6.1), then tighten again crosswise, with the full tightening torque.
4. There are relevant tapped holes on flange A for continuing the shaft train mounting. Again use screws of property class 10.9 (measuring ranges 3 kN·m to 10 kN·m: 12.9), and tighten them with the prescribed moment as specified in Table 6.1.

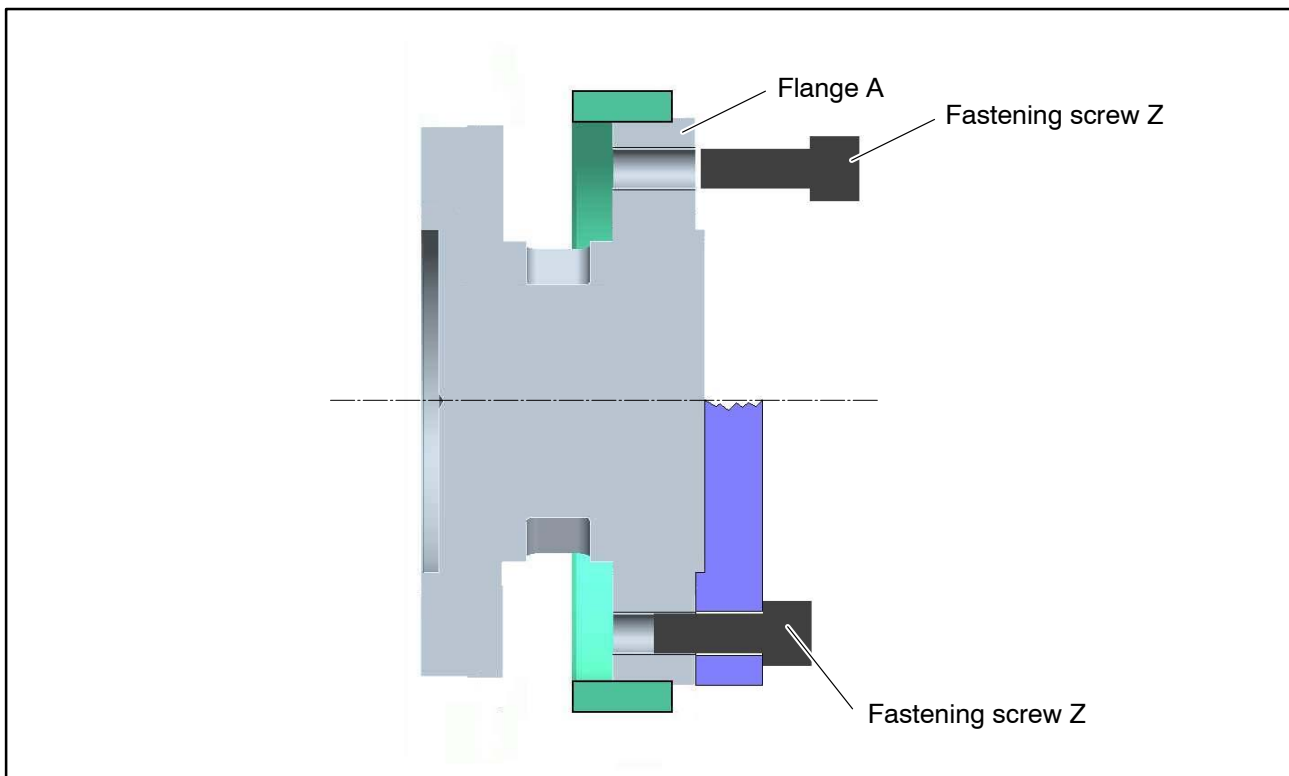

Fig. 6.3: Screw connections, flange A



Important

Use a threadlocker (medium strength, e.g. LOCTITE) to glue the screws into the counter thread to exclude prestressing loss due to screw slackening, in the event of alternating loads.

NOTE

Comply with the maximum thread reach as per Table 6.1. Otherwise significant measurement errors may result from torque shunt, or the transducer may be damaged.

Measuring range	Fastening screws		Prescribed tightening moment
N·m	Z ¹⁾	Property class	N·m
100 / 200	M8	10.9	34
500	M10		67
1 k	M10		67
2 k	M12		115
3 k	M12	12.9	135
5 k	M14		220
10 k	M16		340

Table 6.1: Fastening screws

1) DIN EN ISO 4762; black/oiled/ $\mu_{\text{tot}} = 0.125$



Important

Dry screw connections can result in different friction factors (see VDI 2230, for example). This means a change to the required tightening moments. The required tightening moments can also change if you use screws with a surface or property class other than that specified in Table 6.1, as this affects the friction factor.

7.6 Fitting the protection against contact (option)

The protection against contact comprises two side parts and four cover plates. It is screwed onto the stator housing.



Important

Use a threadlocker (medium strength, e.g. LOCTITE) to glue the connecting screws into the counter thread.

1. Remove the side cover plates on the stator housing (see Fig. 6.4.)

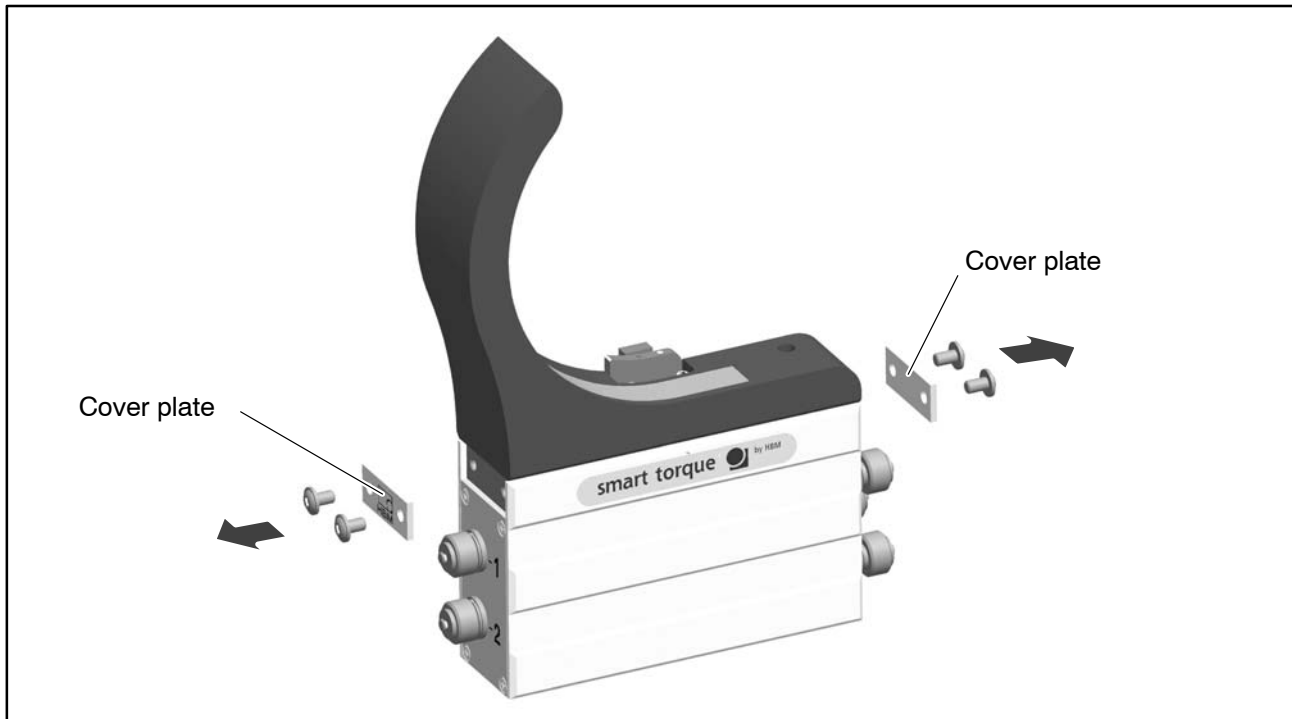

Fig. 6.4: Cover plates on the stator housing

2. **Only for measuring ranges 500 N · m to 3 kN · m and subsequently ordered protection against contact:** some of the tapped holes for the locking screws are covered by attached film. Make a semicircular cutout in the film here, with a minimum radius of 6 mm (use a cutter, as shown in Fig. 6.5, for example).
Now remove the threaded pins from the tapped holes on both sides of the stator.

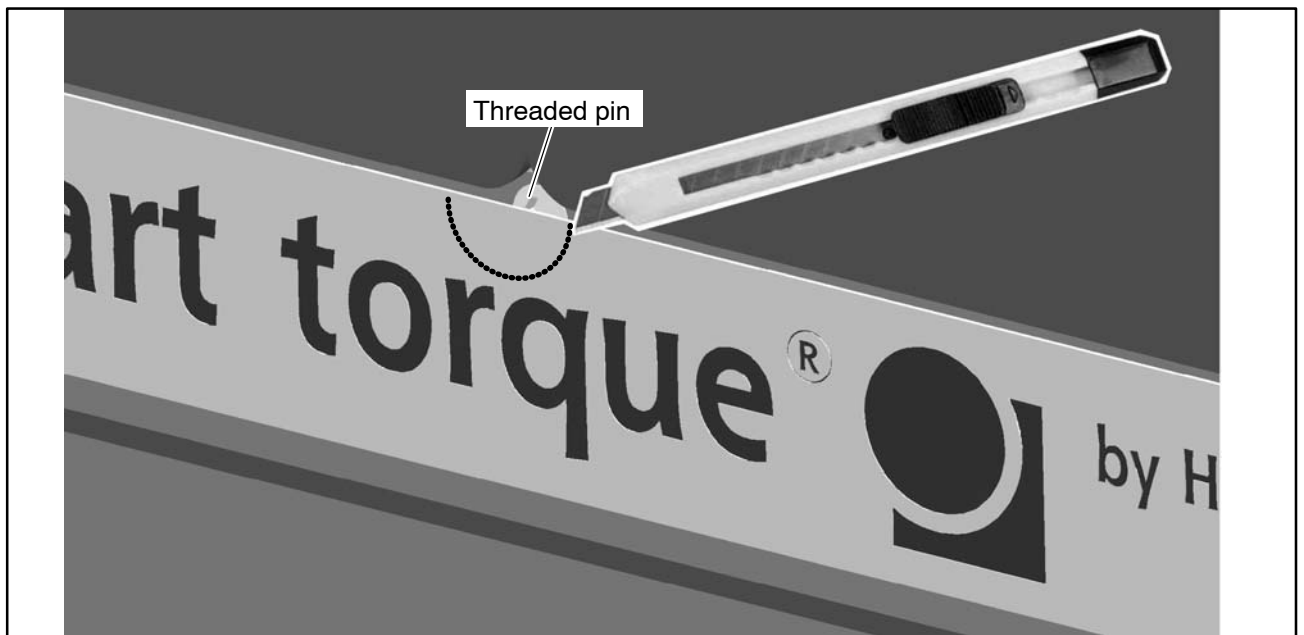

Fig. 6.5: Cut out the film

- 3. For 5 kN·m and 10 kN·m measuring ranges only:** remove the threaded pins from the tapped holes on both sides of the stator. Screw the spacing bolt into the tapped hole on the side of the rotational speed sensor (see Fig. 6.6).

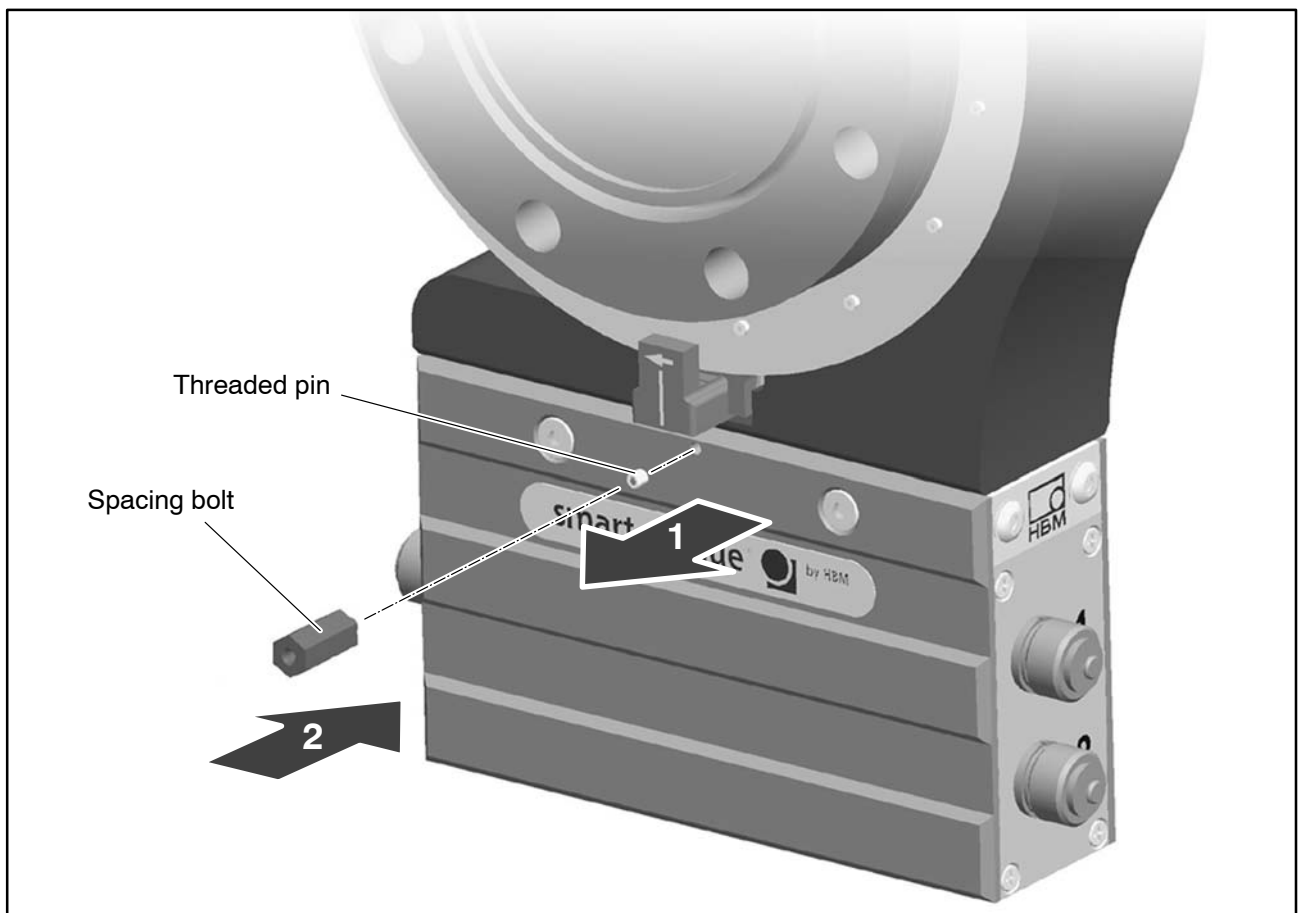

Fig. 6.6: Fit the spacing bolt (for 5 kN·m and 10 kN·m only)

4. Screw the cover plate onto the side parts (screws with hexagon socket 2 a.f.; tightening torque $M_A = 1 \text{ N} \cdot \text{m}$). Note that the cover plate with cutouts must be fitted onto the side with countersunk holes! (see Fig. 6.7).

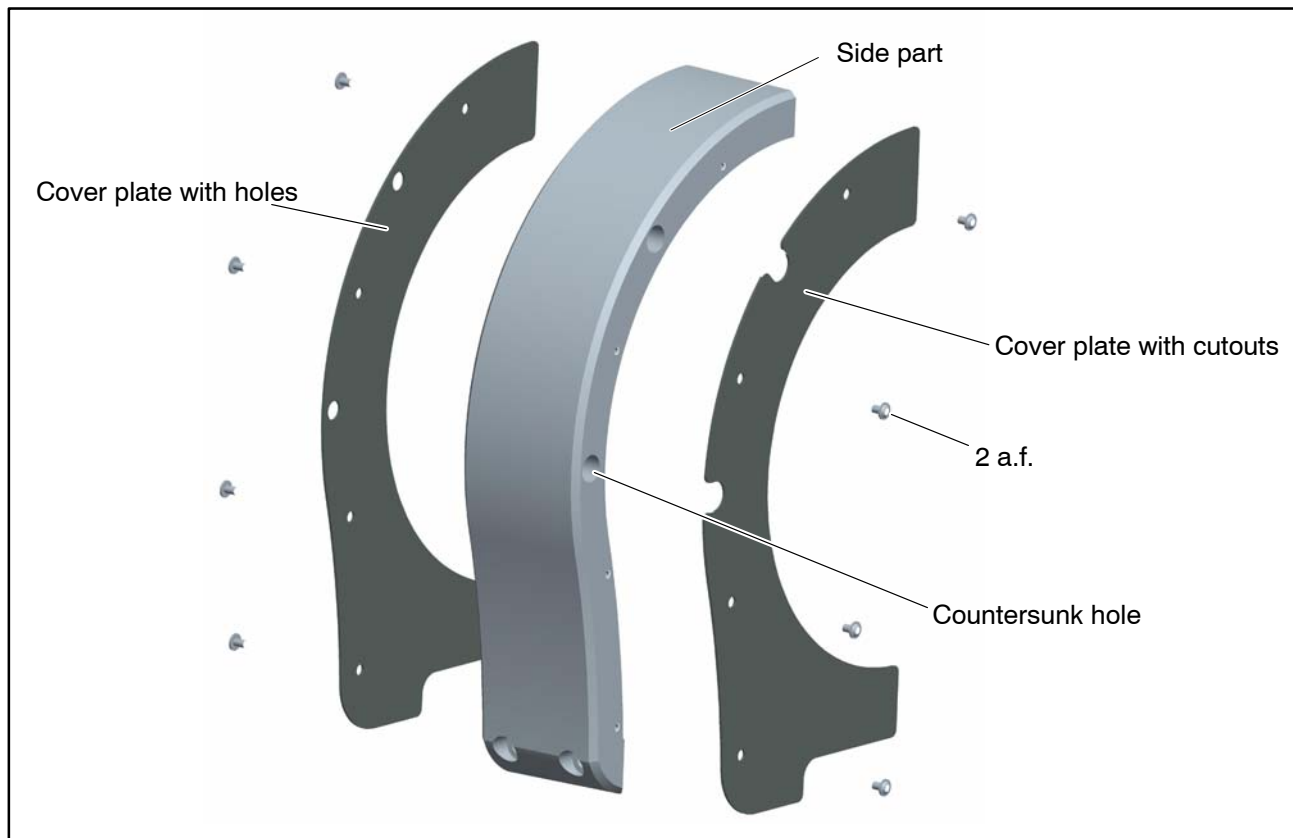

Fig. 6.7: Fit the cover plates



Important

With the 5 kN · m and 10 kN · m measuring ranges, the cover plates of the rotational speed sensor side must be angled at the bottom and fitted as shown in Fig. 6.8.

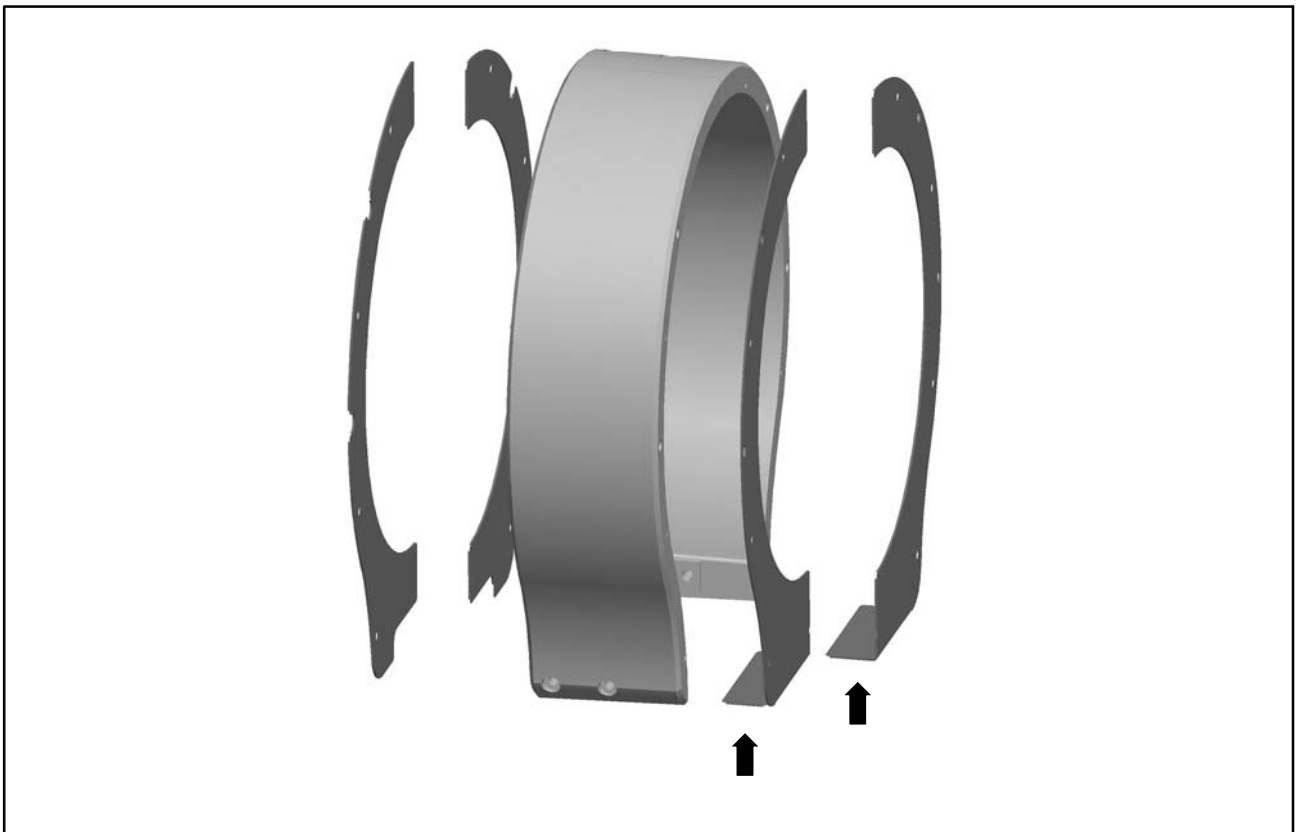

Fig. 6.8: Angled cover plates (5 kN·m and 10 kN·m measuring ranges)

5. Attach each of the side parts to the stator housing with two M6x25 hexagon socket screws (5 a.f.). Hand-tighten the screws.
6. Screw the side parts together at the top, by hand (two M6x30 hexagon socket screws; 5 a.f.).

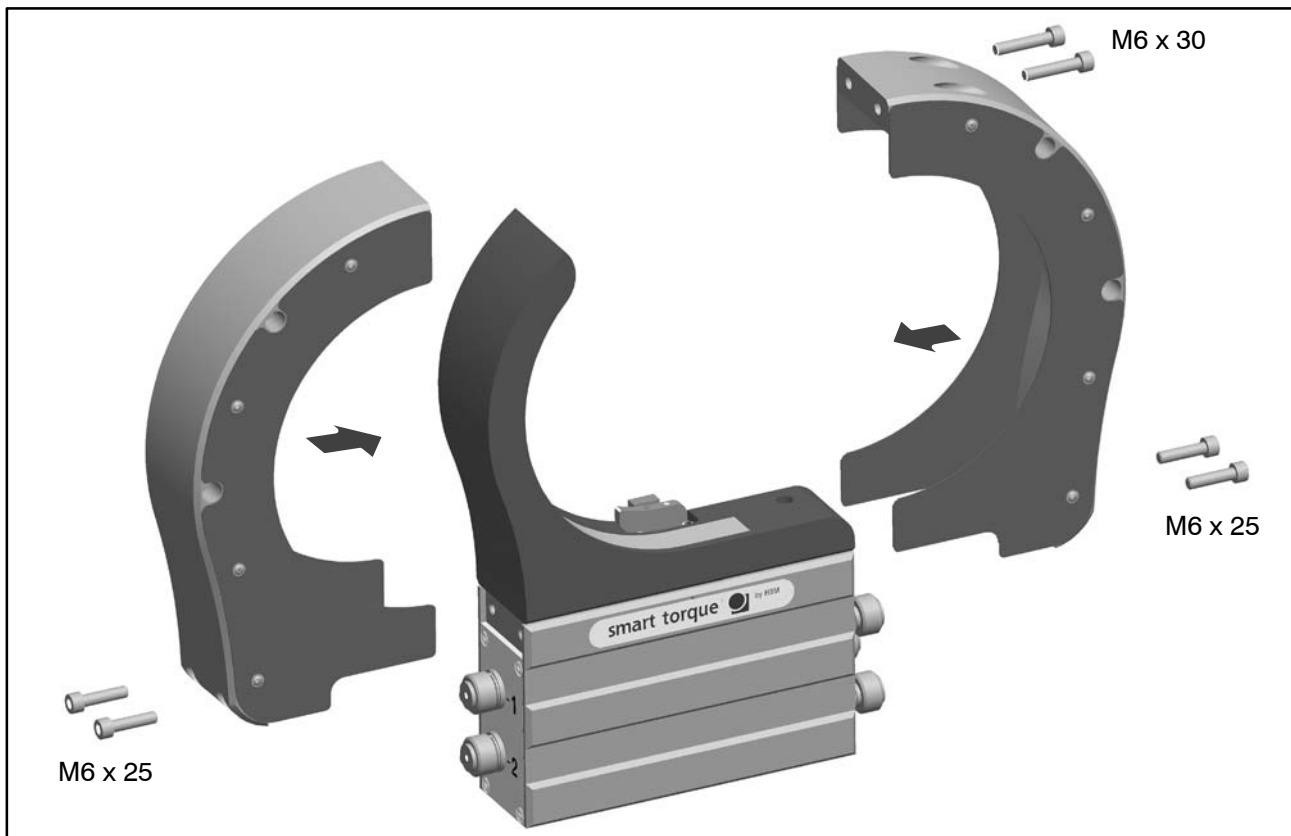

Fig. 6.9: Fit the protection against contact halves

- Align the protection against contact in such a way that its end face is parallel to the stator housing.

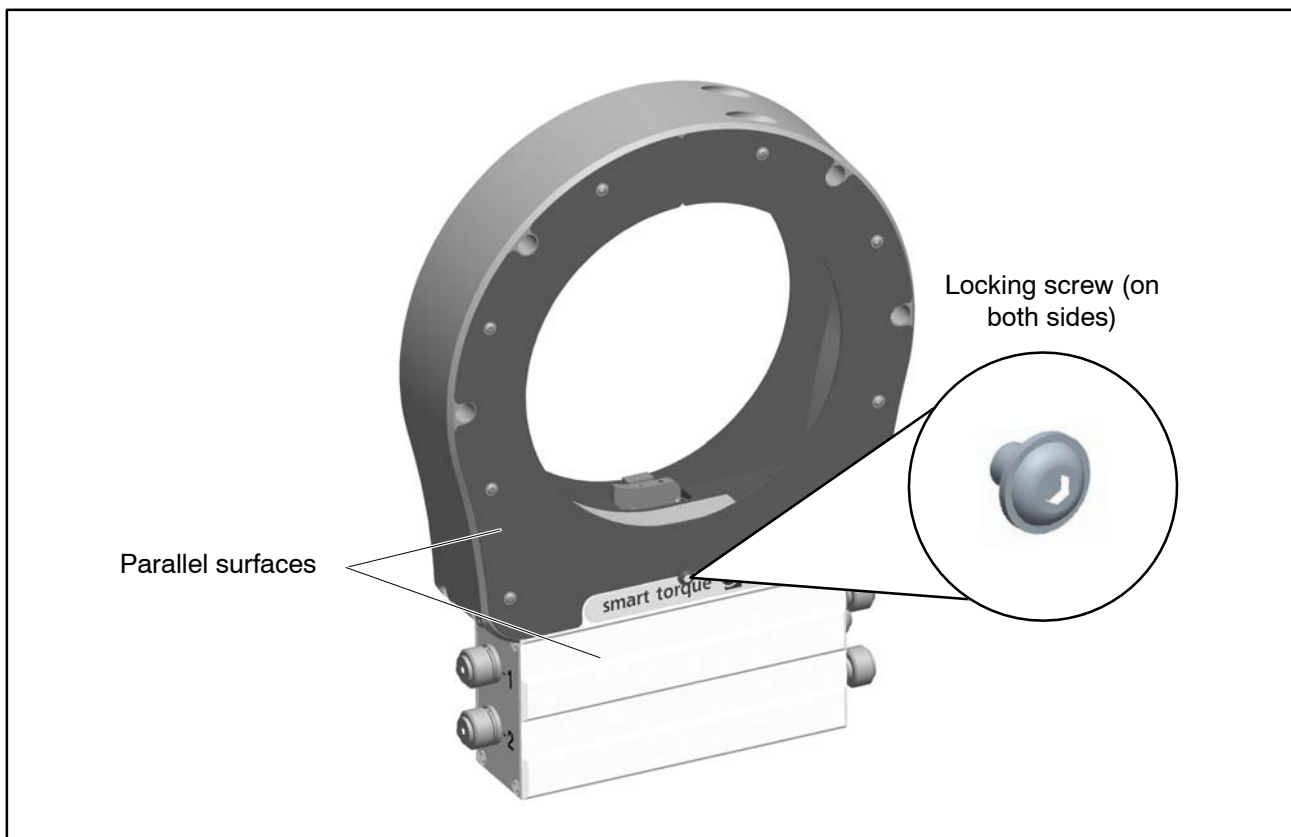

Fig. 6.10: Check for parallelism

8. Now tighten all the screws with a tightening torque M_A of $14 \text{ N} \cdot \text{m}$.
9. Screw in the cover plate locking screws and tighten them at $2 \text{ N} \cdot \text{m}$.

7.7 Installing the stator

On delivery, the stator has already been installed and is ready for operation. There are four tapped holes on the base of the stator housing for mounting the stator. Externally, two with a metric M6 thread, internally, two with a UNF 1/4" thread (closed with a plastic threaded pin).

We recommend using two metric thread DIN EN ISO 4762 fillister-head screws with hexagon sockets of property class 10.9 of the appropriate length (depending on the connection geometry – not included among the components supplied; tightening torque = $14 \text{ N} \cdot \text{m}$).



Tip

To allow the stator to be aligned to the rotor, make sure that repositioning is possible (e.g. oblong holes).

The stator can be mounted radially in any position (an “upside down” installation is possible, for example). You can also install the stator over the protection against contact (option), see Chapter 7.7.3 .

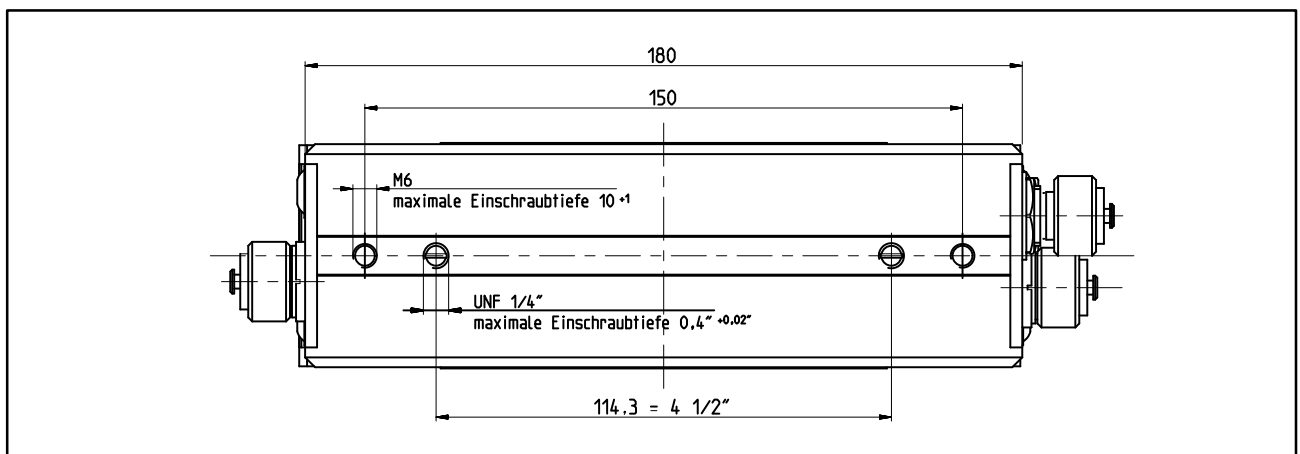

Fig. 6.11: Mounting holes in the stator housing (viewed from below)

With the T12/5 $\text{kN} \cdot \text{m}$ and T12/10 $\text{kN} \cdot \text{m}$ torque transducers, we recommend additionally supporting the stator at the protection against contact. Fig. 6.12 shows an example of how to attach an angle bracket with a bolt (A) or with a threaded rod (B). Note that in this case, the cover plates cannot be fitted.

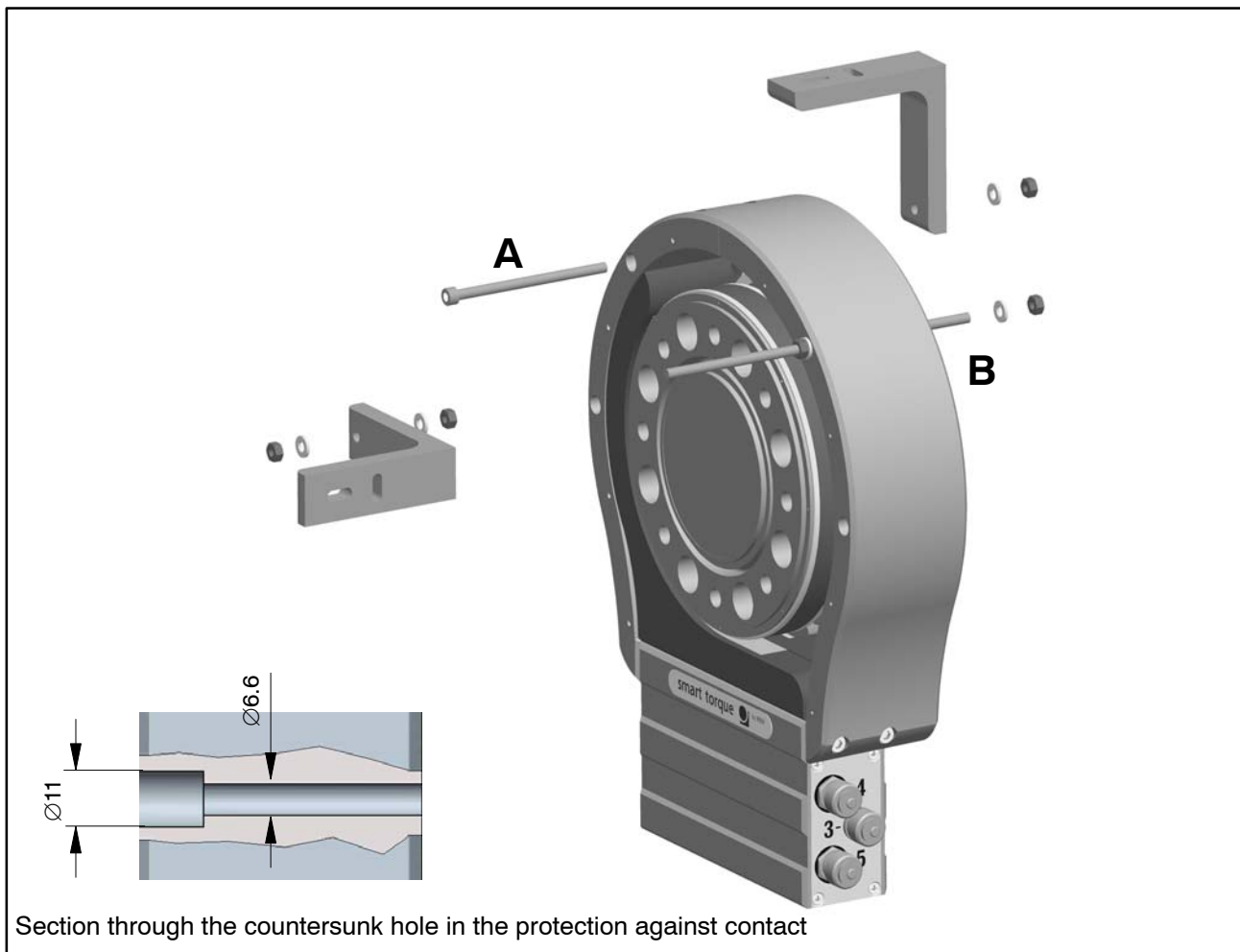

Fig. 6.12: Supporting the stator with an angle bracket (5 kN · m and 10 kN · m)

7.7.1 Preparing with the mounting kit (included among the items supplied)

The supplied mounting kit contains self-adhesive spacers, to make it easier for you to align the stator to the rotor.

Use the spacers to align the rotor and the stator radially and axially.

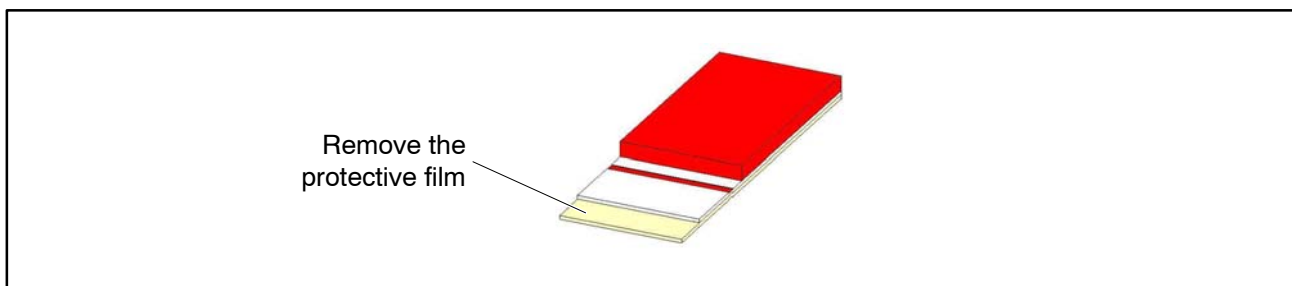

Fig. 6.13: Mounting kit spacer

Radial alignment with spacers

The spacers should preferably be attached to the transmitter head, offset by 90° , as shown in Fig. 6.14. If your stator is equipped with a rotational speed measuring system, you must either shorten the spacers to an appropriate length or attach them slightly offset, next to the rotational speed measuring system.

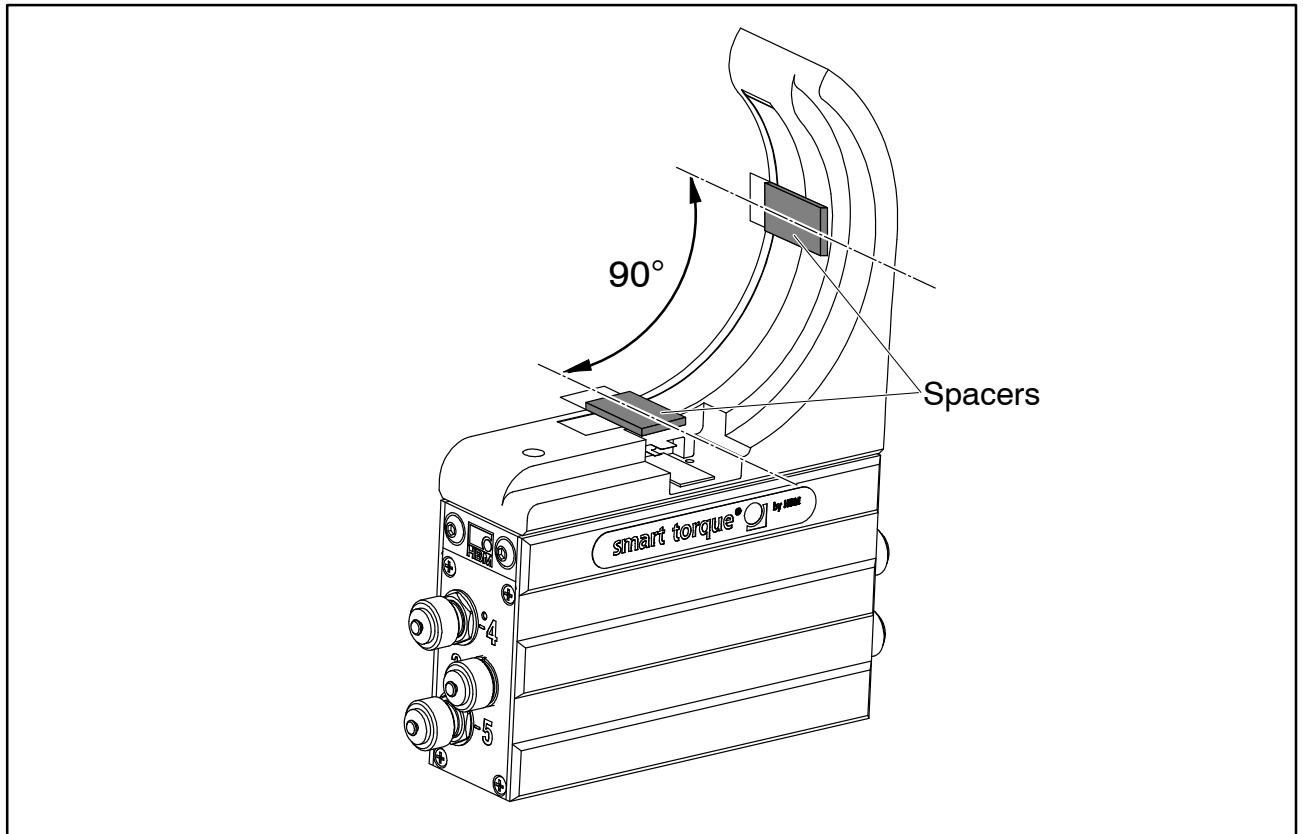

Fig. 6.14: Radial position of the spacers

Axial alignment with spacers

The red line on the spacers is used for axial alignment. Align the spacer in such a way that the outer edge of the transmitter head is in line with the red line (see Fig. 6.15).

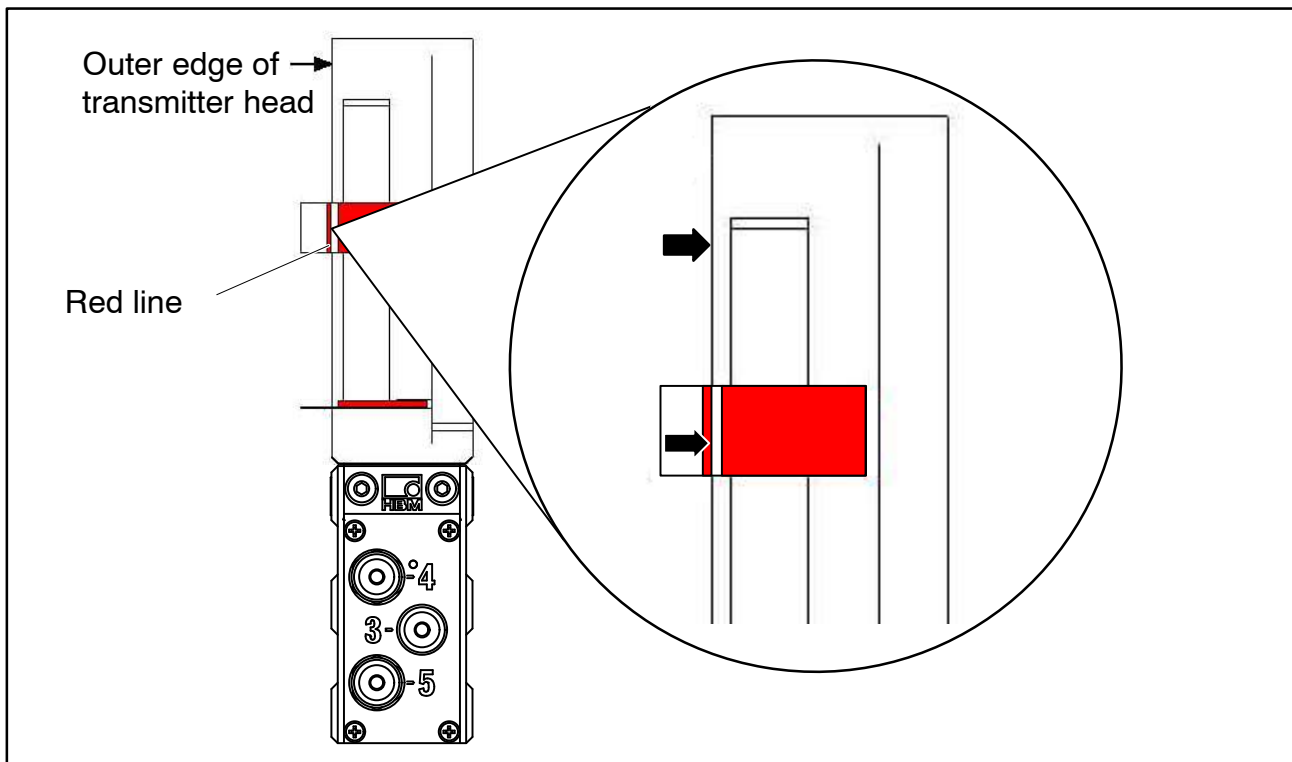

Fig. 6.15: Axial position of the spacers

Now remove the protective film and attach the spacers to the transmitter head, as described.



Important

Remove the spacers after installation.

7.7.2 Aligning the stator

1. Position the stator on an appropriate mounting base in the shaft train, so that there are sufficient opportunities for horizontal and vertical adjustments to be made.
2. Should there be any misalignment in height, compensate for this by inserting adjusting washers.
3. Only tighten the fastening screws by hand, initially.
4. Use the spacers to radially align the stator to the rotor.
5. Use the spacers to axially align the stator to the rotor. The rotor should be in line with the edge of the red spacer, see Fig. 6.16.

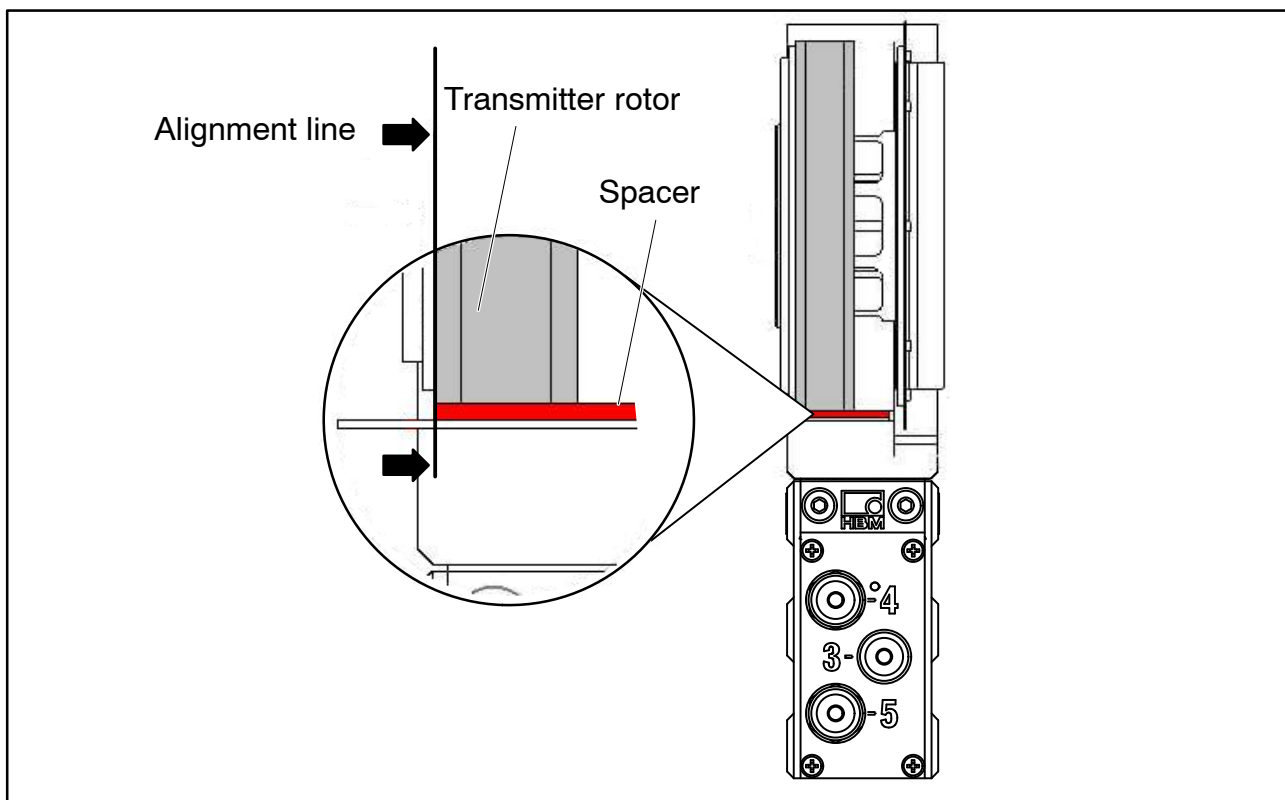

Fig. 6.16: Axial alignment to the rotor

6. Connect the power line (plug 1 or plug 3). Notice the LED to the right of plug 4. The stator is correctly aligned, when the LED successively
 - flashes red for about 10 seconds
 - flashes yellow for about 10 seconds
 - then stays permanently green (CAN Bus) or yellow or green (PROFIBUS).



When data are being exchanged via the CAN Bus or the PROFIBUS, the LED flashes green.

You can also use the T12 Assistant to check for the correct alignment. The LED must stay green in the “Rotor clearance setting mode”.

7. Now fully tighten the fastening screws (tightening torque 14 N·m).
8. Remove the spacers, by first removing the adhesive strip and then the red plastic strip.
9. Make sure that the air gap between the rotor and stator is free from electrically conductive and other foreign matter.

7.7.3 Stator installation over the protection against contact (option)

You can also axially flange the stator over the protection against contact (material: aluminum). Holes are provided in the side parts of the protection against contact for this purpose. For this mounting, we recommend M6 fillister-head screws with hexagon sockets in accordance with DIN EN ISO 4762; black/oiled/ $\mu_{tot}=0.125$, of the appropriate length.

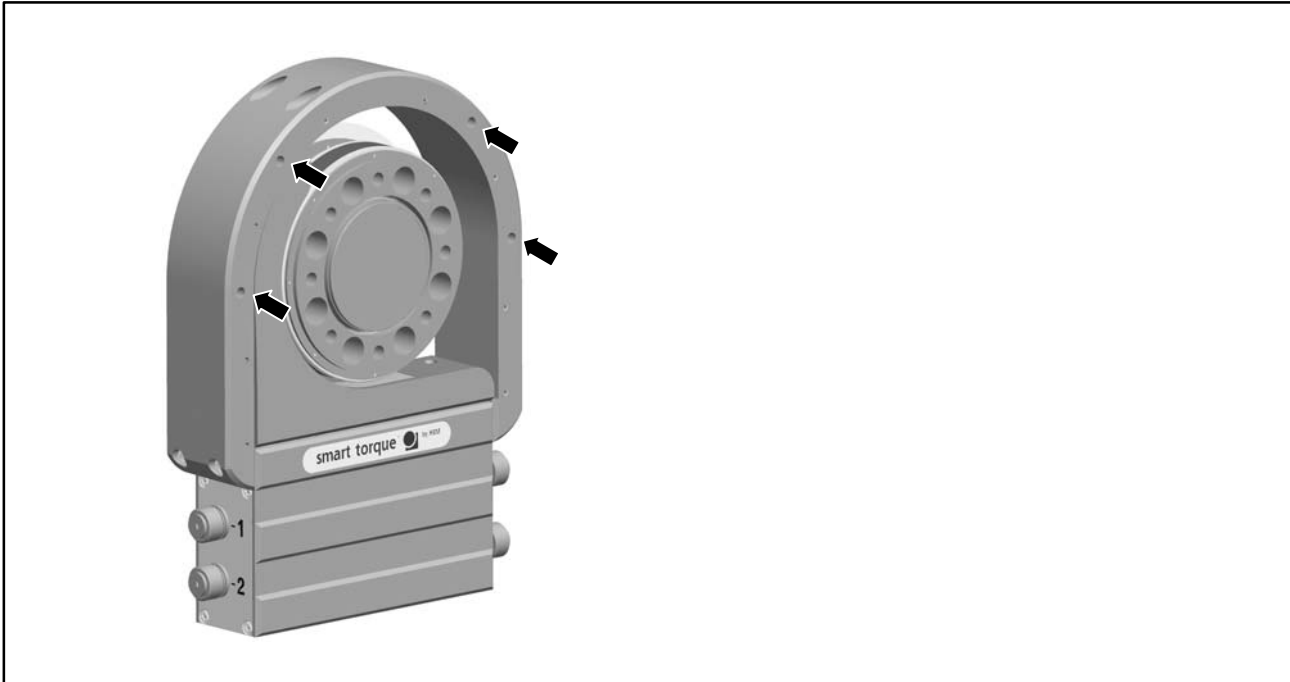
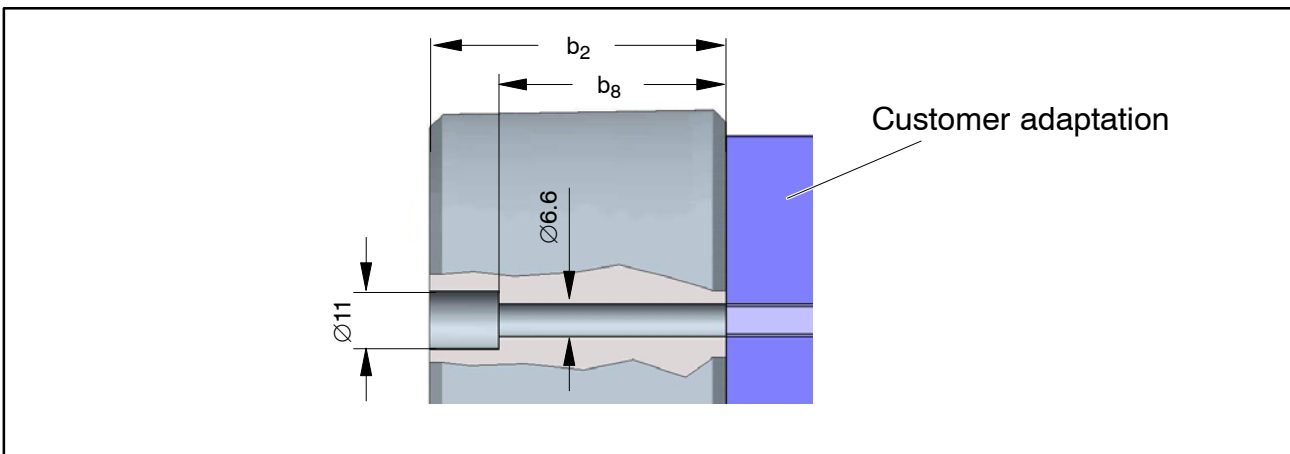

Fig. 6.17: Mounting holes in the protection against contact



Measuring range	Dimensions in mm (1 mm = 0.03937 inches)	
	b ₂	b ₈
100 N·m to kN·m	56	43
5 kN·m	78	65
10 kN·m	86	73

Table 6.2: Mounting hole dimensions

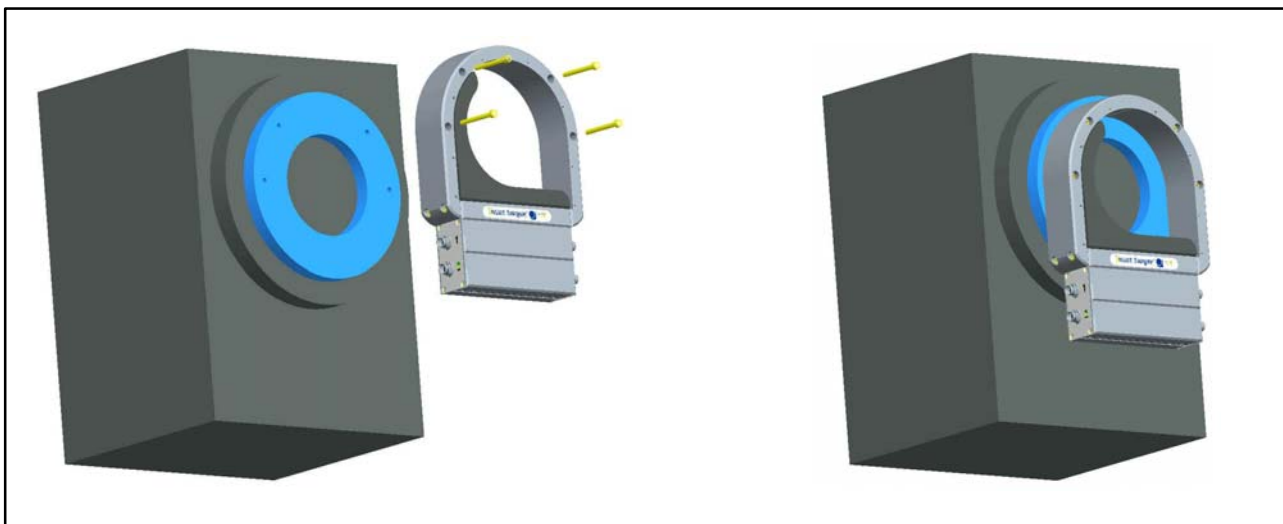

Fig. 6.18: Face-mounting on the engine shielding

7.8 Optical rotational speed/angle of rotation measuring system (option)

As the stator with the optical rotational speed sensor only partially encloses the slotted disc, if there is sufficient space available for installation, you can subsequently move the stator tangentially over the ready-mounted rotor.

For perfect measuring mode, the slotted disc of the rotational speed measuring system must rotate at a defined position in the sensor pickup.

7.8.1 Axial alignment

There is a mark (orientation line) in the sensor pickup for axial alignment. When installed, the slotted disc should be exactly above this orientation line. Divergence of up to ± 2 mm is permissible in measuring mode (total static and dynamic displacement).

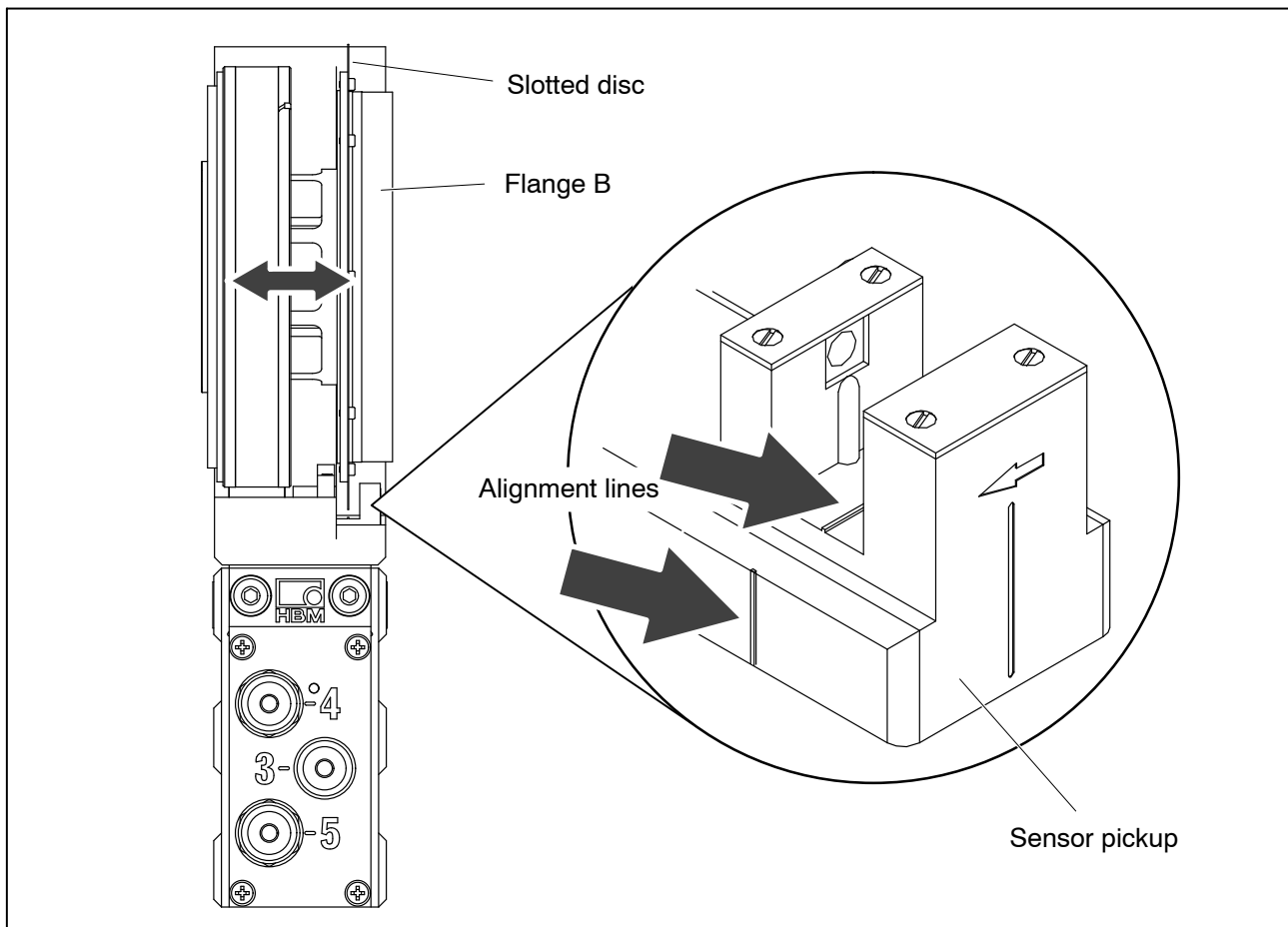

Fig. 6.19: Position of the slotted disc in the rotational speed sensor

7.8.2 Radial alignment

The rotor axis and the optical axis of the rotational speed sensor must be along a line at right angles to the stator platform. A conical machined angle (or a colored mark) in the center of flange B and a vertical marker line on the sensor pickup serve as aids to orientation.

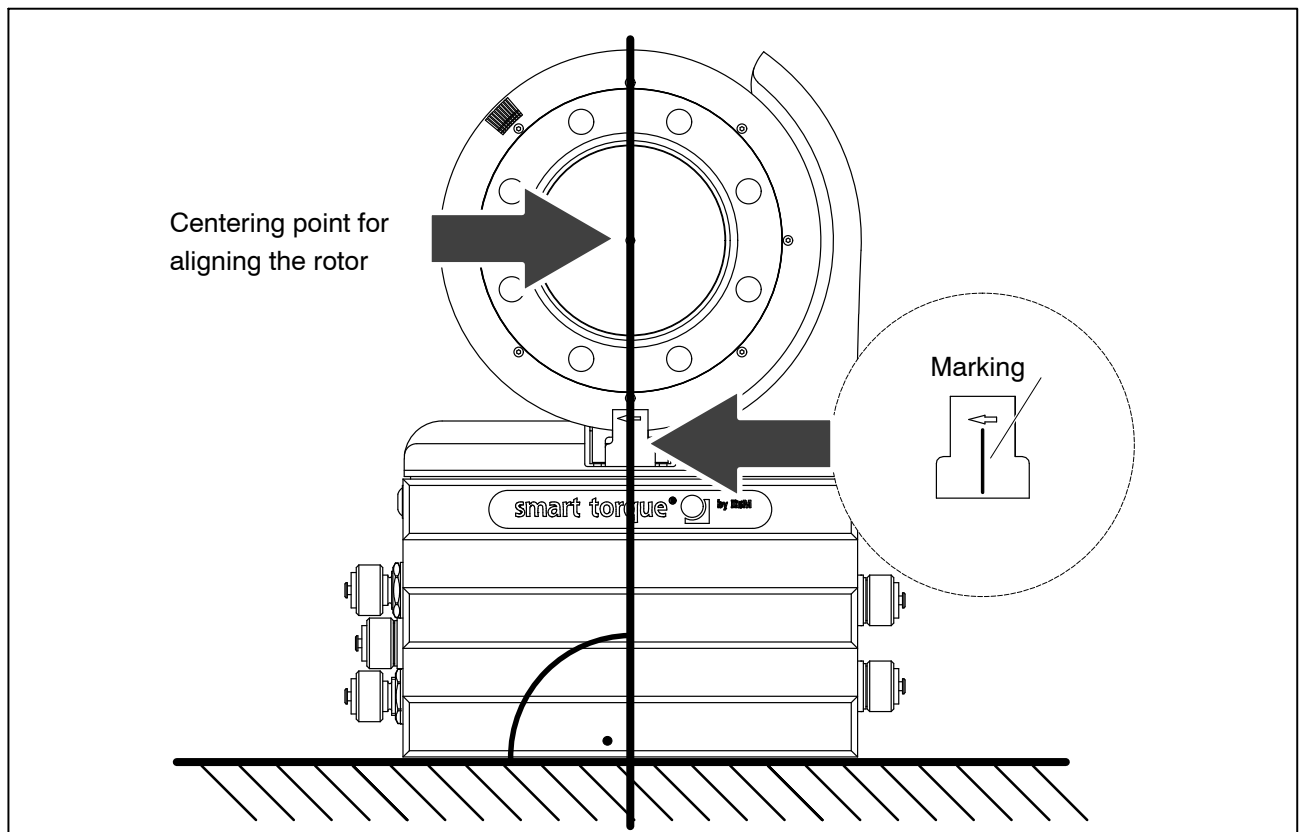

Fig. 6.20: Alignment marks on rotor and stator

Connect the power line (plug 1).

Switch the LED display mode of the T12 Assistant to “optical rotational speed system” setting mode and turn the rotor. Notice the LED to the right of plug 4; this must stay green if the setting is correct (also see Chapter 8.3).



Important

Angle of rotation measurement is not suitable for static and quasi-static applications!

8 LED status display

The LED in the stator housing (next to device plug 4) has three display modes: standard (measuring mode), rotor clearance setting mode and setting mode for the optical rotational speed system.

8.1 Measuring mode operation

LED color	Significance
Flashing green (fast)	SDO transfer taking place
Flashing green	CAN device has operational status
Green	For PROFIBUS option only: Data exchange taking place ¹⁾
Flashing yellow (slow)	Rotor communication taking place
Yellow	For PROFIBUS option only: Searching for the baud rate, or parameterization or configuration taking place, or no data exchange taking place ¹⁾
Flashing red	Overflow for measured value (amplifier input, measured value ovfl.), frequency or analog output
Red	Error situation

¹⁾ When PROFIBUS option exists: Messages to the PROFIBUS take precedence over messages to the CAN Bus.

8.2 Rotor clearance setting mode operation

LED color	Significance
Green	Rotor-stator alignment is OK
Yellow	Rotor-stator alignment is borderline
Red	Rotor-stator alignment is not OK

8.3 Rotational speed measuring system setting mode operation

LED color	Significance
Green	The position of the two sensors is OK, the signals (F1/F2) are 90° or 270° phase-shifted and can be correctly evaluated
Yellow	The phase relation of the two sensor signals is not optimum, there is a variation of 10° to 30°
Red	The phase relation of the two sensor signals is not correct, there is a variation of more than 30°

For more information on setting mode, look in the T12 Assistant online Help.

9 Electrical connection

9.1 General information

Detailed instructions for connecting the T12 to the CAN Bus or the PROFIBUS can be found in the “T12 CAN Bus/PROFIBUS” interface description (in pdf format) on the T12 system CD.

To make the electrical connection between the torque transducer and the measuring amplifier, we recommend using shielded, low-capacitance measurement cables from HBM.

With extension cables, make sure that there is a proper connection with minimum contact resistance and good insulation. All plug connections or swivel nuts must be fully tightened.

Do not route the measurement cables parallel to power lines and control circuits. If this cannot be avoided (in cable pits, for example), maintain a minimum distance of 50 cm and also draw the measurement cable into a steel tube.

Avoid transformers, motors, contactors, thyristor controls and similar stray-field sources.



Consider longer cable of approximately 40cm due to the installation of the wounded core (toroidal core).



Important

Transducer connection cables from HBM with plugs attached are identified in accordance with their intended purpose (Md or n). When cables are shortened, inserted into cable ducts or installed in control cabinets, this identification can get lost or become concealed. If this is the case, it is essential for the cables to be re-labeled!

Tape wound core (toroidal core):

To suppress high frequencies a tape wound core (toroidal core) on the power cable has to be used. Use at least 3 loops of the cable.

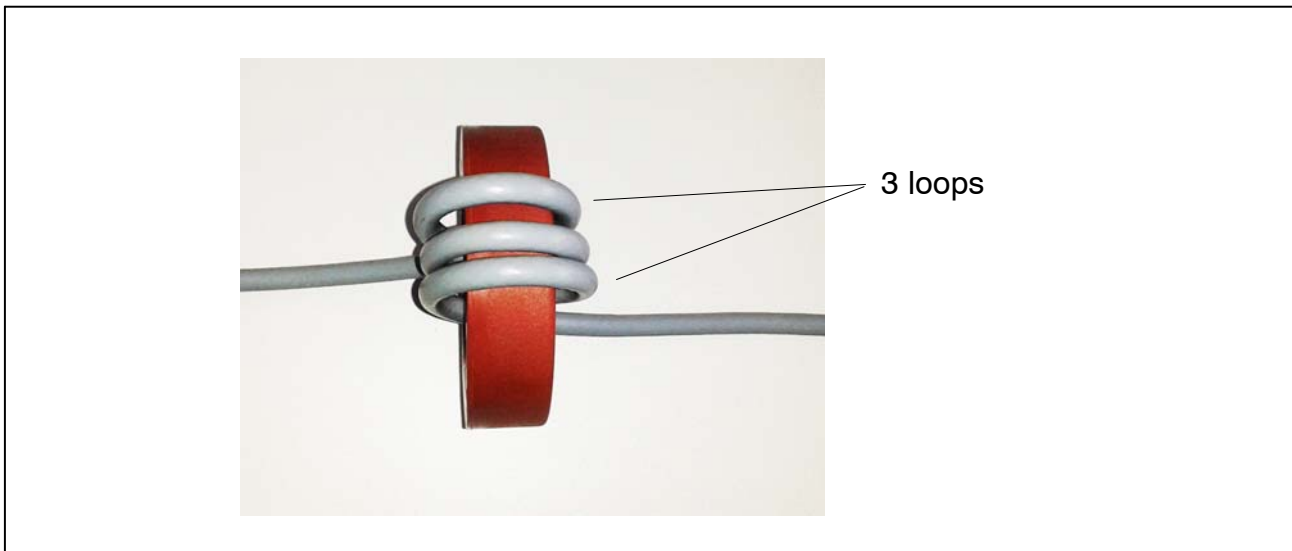

Fig. 6.21: Installation Example

If the core has to be removed for any purpose (e.g. for maintenance), it must be replaced on the cable. Use only wounded core (toroidal core) of the correct type.

Type: Vitroperm R

Model No.: T60006–22063W517

Size: external diameter x internal diameter x height = 63 x 50 x 25

The core should be placed as close as possible to the connector. However, prevent stress on the connector due to the extra weight of the cable.

NOTE

For US stator Version Option 9, Code U the use of a tape wound core (toroidal core) on the power cable (plug 1 or plug3) is mandatory to ensure compliance with FCC regulations.



Important

For US Version Option 9, Code U the use of a tape wound core (toroidal core) on the signal cable is mandatory to ensure compliance with FCC regulations.



The cables and plugs for connectors 1, 2 and 3 are compatible with the T10FS torque flange.

9.2 Shielding design

The cable shield is connected in accordance with the Greenline concept. This encloses the measurement system (without the rotor) in a Faraday cage. It is important that the shield is laid flat on the housing ground at both ends of the cable. Any electromagnetic interference active here does not affect the measurement signal. Special electronic coding methods are used to protect the purely digital signal transmission between the transmitter head and the rotor from electromagnetic interference.







In the case of interference due to potential differences (compensating currents), supply voltage zero and housing ground must be disconnected on the amplifier and a potential equalization line established between the stator housing and the amplifier housing (copper conductor, 10 mm² wire crosssection).

Should differences in potential between the machine rotor and stator cause interference, because of unchecked leakage, for example, this can usually be overcome by connecting the rotor definitively to ground, by a wire loop, for example. The stator should be fully grounded in the same way.

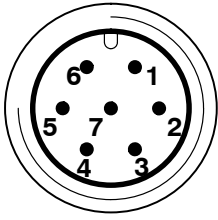
9.3 Connector pin assignment

Assignment for plug 1:

Supply voltage and frequency output signal.

Binder 423 device plug  Top view	Plug pin	Assignment	Color code	D-Sub-plug pin
	1	Torque measurement signal (frequency output; 5 V ¹ /0)	wh	13
	2	Supply voltage 0 V; 	bk	5
	3	Supply voltage 18 V  30 V	bu	6
	4	Torque measurement signal (frequency output; 5 V ¹ /V)	rd	12
	5	Measurement signal 0 V;  symmetrical	gy	8
	6	Shunt signal trigger 5 V  30 V and TEDS for torque	gn	14
	7	Shunt signal 0 V; 	gy	8
		Shielding connected to housing ground		

1) RS-422 complementary signals; with cable lengths exceeding 10 m, we recommend using a termination resistor R=120 ohms between the wires (wh) and (rd).



Important



If plug 1 is used to power the device a tape wound core (toroidal core) is necessary to suppress high frequencies in order to ensure compliance with FCC regulations

NOTE

Torque transducers are only intended for operation with a DC supply voltage (separated extra-low voltage), see page 43.

Assignment for plug 2:

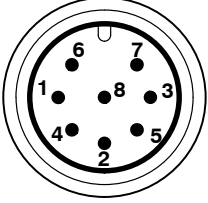
Rotational speed measuring system



	Plug pin	Assignment	Color code	Sub-D plug pin
Binder 423 device plug  Top view	1	Rotational speed measurement signal (pulse string, 5 V ¹); 0°	rd	12
	2	Not in use	bu	2
	3	Rotational speed measurement signal (pulse string, 5 V ¹); phase-shifted 90°	gy	15
	4	Not in use	bk	3
	5	TEDS for rotational speed	vt	9
	6	Rotational speed measurement signal (pulse string, 5 V ¹); 0°	wh	13
	7	Rotational speed measurement signal (pulse string, 5 V ¹); phase-shifted 90°	gn	14
	8	Measurement signal 0 V 	bk ²⁾	8
		Shielding connected to housing ground		

¹⁾ RS-422 complementary signals; with cable lengths exceeding 10 m, we recommend using R=120 ohms termination resistors between wires (rd) and (wh), as well as (gy) and (gn).

²⁾ Color code brown (br) for Kab 163 and Kab 164.

Assignment for plug 2:

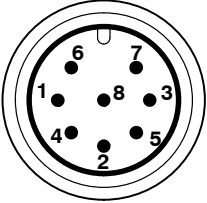
Rotational speed measuring system with reference signal





	Plug pin	Assignment	Color code	Sub-D plug pin	
Binder 423 device plug  Top view	1	Rotational speed measurement signal (pulse string, 5 V ¹); 0°	rd	12	
	2	Reference signal (1 pulse/rev., 5 V ¹)	bu	2	
	3	Rotational speed measurement signal (pulse string, 5 V); phase-shifted 90°	gy	15	
	4	Reference signal (1 pulse/rev., 5 V ¹)	bk	3	
	5	TEDS for rotational speed	vt	9	
	6	Rotational speed measurement signal (pulse string, 5 V ¹); 0°	wh	13	
	7	Rotational speed measurement signal (pulse string, 5 V); phase-shifted 90°	gn	14	
	8	Measurement signal 0 V 	bk ²⁾	8	
		Shielding connected to housing ground			

1) RS-422 complementary signals; with cable lengths exceeding 10 m, we recommend using R=120 ohms termination resistors between wires (rd) and (wh), (bu and (bk), (gy) and (gn).

2) Color code brown (br) for Kab 163 and Kab 164.

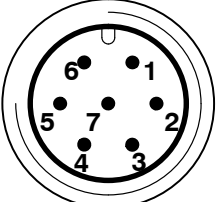
Assignment for plug 3:

Supply voltage and voltage output signal.

	Plug pin	Assignment
Binder 423 device plug  Top view	1	Torque/rotational speed measurement signal (voltage output; 0 V ) or rotational speed measurement signal (0 V)
	2	Supply voltage 0 V; 
	3	Supply voltage 18 V to 30 V DC
	4	Torque measurement signal (voltage output; ± 10 V) or rotational speed measurement signal (± 10 V)
	5	Not in use
	6	Shunt signal trigger 5 V to 30 V and TEDS for torque
	7	Shunt signal 0 V; 
		Shielding connected to housing ground



Important

If plug 3 is used to power the device a tape wound core (toroidal core) is necessary to suppress high frequencies in order to ensure compliance with FCC regulations.

NOTE

Do not use cable KAB149 to connect the voltage output signal at AP01i to ML01B of the MGCplus system!

This cable is only suitable for connecting the frequency output signal.



The analog output is designed as a monitoring output. The power transmission of the torque transducer can cause interference on the connected cable of up to 40 mV at 13.56 MHz. This interference can be suppressed by connecting a 100 nF capacitor in parallel, directly at the connected measuring instrument.

Assignment for plug 4:

Standard CAN Bus; A-coded, black washer

Binder 713 (M12x1)	Plug pin	Assignment	Color code
<p>Top view</p>	1	Shield	–
	2	Not in use	–
	3	CAN ground	–
	4	CAN HIGH-dominant high	wh
	5	CAN LOW-dominant low	bu
			Shielding connected to housing ground

Assignment for plug 5:

CAN Bus; second device plug; A-coded, black washer

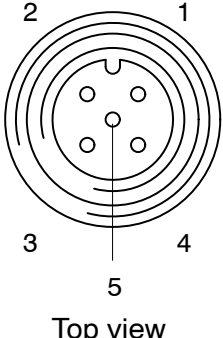
Binder 713 (M12x1)	Plug pin	Assignment	Color code
 <p>Top view</p>	1	Shield	–
	2	Not in use	–
	3	CAN ground	–
	4	CAN HIGH-dominant high	wh
	5	CAN LOW-dominant low	bu
			Shielding connected to housing ground

Assignment for plug 5:

PROFIBUS (option); B-coded, violet washer

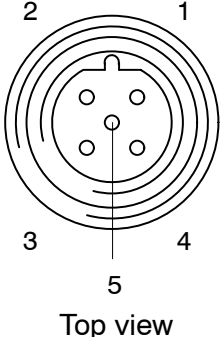
Binder 715 (M12x1)	Plug pin	Assignment
 <p>Top view</p>	1	5 V (typ. 50 mA)
	2	PROFIBUS A
	3	PROFIBUS ground
	4	PROFIBUS B
	5	Shield

9.4 Supply voltage

The transducer must be operated with a separated extra-low voltage (nominal (rated) supply voltage 18 to 30 V_{DC}). You can supply one or more torque flanges within a test bench at the same time. Should the device be operated on a DC voltage network¹⁾, additional precautions must be taken to discharge excess voltages.

The notes in this section relate to the self-contained operation of the T12 without HBM system solutions.

The supply voltage is electrically isolated from signal outputs and shunt signal inputs. Connect a separated extra-low voltage of 18 V to 30 V to pin 3 (+) and pin 2 (⏏) of plug 1 or 3. We recommend that you use HBM cable KAB 8/00–2/2/2 and the relevant Binder sockets, that at nominal (rated)

voltage (24 V) can be up to 50 m long and in the nominal (rated) voltage range, 20 m long (see Accessories, page 88).

If the permissible cable length is exceeded, you can feed the supply voltage in parallel over two connection cables (plugs 1 and 3). This enables you to double the permissible length. Alternatively, install an on-site power supply.

If you feed the supply voltage through an unshielded cable, the cable must be twisted (interference suppression). We also recommend that a ferrite element should be located close to the connector plug on the cable, and that the stator should be grounded.



Important

The instant you switch on, a current of up to 4 A may flow and this may switch off power supplies with electronic current limiters.

¹⁾ Distribution system for electrical energy with greater physical expansion (over several test benches, for example) that may possibly also supply consumers with high nominal (rated) currents.

10 Shunt signal

The T12 torque transducer supplies a shunt signal, at either 50% or 10% of the nominal (rated) torque, as selected. Activate this function via the T12 Assistant or the shunt signal trigger on plug 1 or plug 3 (see Section 9.3). The last shunt selected in the T12 Assistant is then triggered.



The internal signal conditioning may cause a delay in triggering of about 5 seconds.

To obtain stable conditions, we recommend activating the shunt signal only once the transducer has been warming up for 15 minutes.

The framework conditions for reproducibility (e.g. the mounting conditions) must be established in order to reproduce the measured values in the manufacturing certificate.



Important

The transducer should not be under load when the shunt signal is being measured, as the signal is applied additively.



After about 5 minutes, the shunt signal is automatically deactivated.

11 Load-carrying capacity

Nominal (rated) torque can be exceeded statically up to the limit torque. If the nominal (rated) torque is exceeded, additional irregular loading is not permissible. This includes longitudinal forces, lateral forces and bending moments. Limit values can be found in the “Specifications” chapter (Chapter 15, page 56).

Measuring dynamic torque

The torque transducer is suitable for measuring static and dynamic torques. The following apply to the measurement of dynamic torque:

- The T12 calibration run for static measurements is also valid for dynamic torque measurements.
- The natural frequency f_0 of the mechanical measuring system depends on the moments of inertia J_1 and J_2 of the connected rotating masses and the T12's torsional stiffness.

Use the equation below to approximately determine the natural frequency f_0 of the mechanical measuring system:

$$f_0 = \frac{1}{2\pi} \cdot \sqrt{c_T \cdot \left(\frac{1}{J_1} + \frac{1}{J_2} \right)}$$

f_0 = natural frequency in Hz
 J_1, J_2 = mass moment of inertia in $\text{kg}\cdot\text{m}^2$
 c_T = torsional stiffness in $\text{N}\cdot\text{m}/\text{rad}$

- The maximum oscillation width is 200% (measuring range 3 $\text{kN}\cdot\text{m}$ to 10 $\text{kN}\cdot\text{m}$: 160%) of the typical nominal (rated) torque for the T12 (see “Specifications”, page 56) The oscillation width must lie between the maximum upper and lower torques of the defined loading range. The same also applies to transient resonance points.

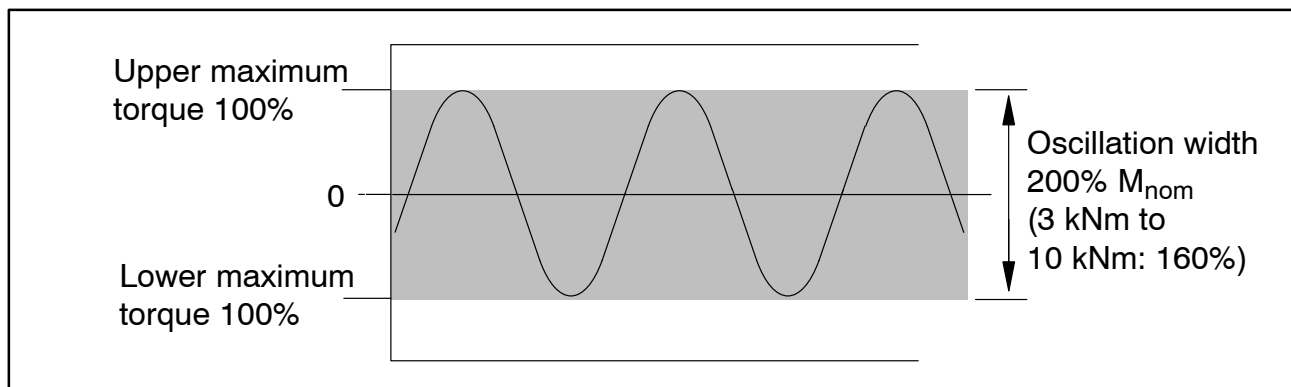

Fig. 10.1: Permissible dynamic loading

12 TEDS

TEDS (Transducer Electronic Data Sheet) allows you to store the transducer data (characteristic values) in a chip, that can be read out by a connected measuring instrument.

There are two TEDS blocks in the T12 digital torque transducer:

- TEDS 1 (torque): a choice of voltage sensor or frequency sensor/pulse sensor
- TEDS 2 (rotational speed/angle of rotation): frequency sensor/pulse sensor

The data are written automatically into the TEDS blocks by the T12 Assistant, when the parameters are stored. The same menu is used to select whether the device should be presented as a voltage sensor or as a frequency sensor or as a frequency or pulse sensor. A template is also stored, which provides the conversion factors for the different physical units.

The T12 is a transducer, that is to say, the T12 does not read the TEDS blocks, it only writes them. (We therefore strongly advise against editing the values with the HBM TEDS Editor, for example!)

You can read the data of the TEDS block with the TEDS Editor.



Important

To ensure that the data of the TEDS blocks correspond to the properties of the T12 torque transducer, you must not overwrite the information from the measuring amplifier.

For more information on TEDS, look in the T12 Assistant online Help.

Content of the TEDS memory as defined in IEEE 1451.4

The information in the TEDS memory is organized into areas, which are prestructured to store defined groups of data in table form.

Only the entered values are stored in the TEDS memory itself. The amplifier firmware assigns the interpretation of the respective numerical values. This places a very low demand on the TEDS memory. The memory content is divided into three areas:

Area 1:

An internationally unique TEDS identification number (cannot be changed).

Area 2:

The base area (basic TEDS), to the configuration defined in standard IEEE1451.4. The transducer type, the manufacturer and the transducer serial number are contained here.

Example:

TEDS content of a T12/1 kN·m transducer

TEDS	
Manufacturer	HBM (31)
Model	T12 (15)
Version letter	A
Version number	2 first position of stator ident no.
Serial number	7 first position of stator ident no.

Area 3:

Data specified by the manufacturer and the user are contained in this area. Typical values for an HBM T12/1 kN·m torque transducer are shown in the “Value” column of the table below.

Torque

HBM has already written the “Frequency/Pulse Sensor” and “High Level Voltage Output Sensor” templates for the torque measurand.

Template: Frequency/Pulse Sensor				
Parameter	Value	Unit	Required user rights	Explanation
Transducer Electrical Signal Type	Pulse Sensor		ID	
Minimum Torque	0.000	N·m	CAL	The physical measurand and unit are defined when the template is created, after which they cannot be changed.
Maximum Torque	1000	N·m	CAL	
Pulse Measurement Type	Frequency			
Minimum Electrical Value	10000	Hz	CAL	The difference between these values is the nominal (rated) sensitivity.
Maximum Electrical Value	15000	Hz	CAL	
Mapping Method	Linear			
Discrete Signal Type	Bipolar		ID	
Discrete Signal Amplitude	4	V		
Discrete Signal Configuration	Single			
Transducer Response Time	0	seconds		
Excitation Level nom	24	V		
Excitation Level min	18	V		
Excitation Level max	30	V		
Excitation Type	DC			
Excitation Current draw	0.5	A		
Calibration Date	1-Nov-2006	CAL		Date of the last calibration or creation of the manufacturing certificate (if no calibration carried out), or of the storage of the TEDS data (if only nominal (rated) values from the data sheet were used). Format: day-month-year. Abbreviations for the months: Jan, Feb, Mar, Apr, May, Jun, Jul, Aug, Sep, Oct, Nov, Dec.
Calibration Initials	HBM or PTB		CAL	Initials of the calibrator or calibration laboratory concerned.
Calibration Period (Days)	0	days	CAL	Time before recalibration, calculated from the date specified under Calibration Date.
Measurement location ID	0		USR	Identification number for the measuring point. Can be assigned according to the application. Possible values: a number from 0 to 2047.

Template: High Level Voltage Sensor				
Parameter	Value	Unit	Required user rights	Explanation
Minimum Torque	0.000	N · m	CAL	The physical measurand and unit are defined when the template is created, after which they cannot be changed.
Maximum Torque	1000	N · m	CAL	
Minimum Electrical Value	0	V	CAL	The difference between these values is the nominal (rated) sensitivity.
Maximum Electrical Value	10	V	CAL	
Discrete Signal Type	Bipolar		ID	
Discrete Signal Amplitude	5	V		
Discrete Signal	Single			
Transducer Response Time	0			
Excitation Level nom	24	V		
Excitation Level min	18	V		
Excitation Level max	30	V		
Excitation Type	DC			
Excitation Current draw	0.5	A		
Calibration Date	1-Nov-2006	CAL		Date of the last calibration or creation of the manufacturing certificate (if no calibration carried out), or of the storage of the TEDS data (if only nominal (rated) values from the data sheet were used). Format: day-month-year. Abbreviations for the months: Jan, Feb, Mar, Apr, May, Jun, Jul, Aug, Sep, Oct, Nov, Dec.
Calibration Initials	HBM or PTB		CAL	Initials of the calibrator or calibration laboratory concerned.
Calibration Period (Days)	0	days	CAL	Time before recalibration, calculated from the date specified under Calibration Date.
Measurement Location ID	0		USR	Identification number for the measuring point. Can be assigned according to the application. Possible values: a number from 0 to 2047.

Rotational speed/angle of rotation

HBM has already written the “Frequency/Pulse Sensor” template for the rotational speed measurand.

Template: Frequency/Pulse Sensor				
Parameter	Value	Unit	Required user rights	Explanation
Transducer Electrical Signal Type	Pulse Sensor		ID	
Minimum Frequency	0.000	Hz	CAL	The physical measurand and unit are defined when the template is created, after which they cannot be changed.
Maximum Frequency	108.000 k	Hz	CAL	
Pulse Measurement Type	Frequency			
Minimum Electrical Value	0	Hz	CAL	
Maximum Electrical Value	108.000 k	Hz	CAL	
Mapping Method	Linear			
Discrete Signal Type	Bipolar		ID	
Discrete Signal Amplitude	4	V		
Discrete Signal Configuration	Double phase plus zero index			
Transducer Response Time	0	seconds		
Excitation Level nom	24	V		
Excitation Level min	18	V		
Excitation Level max	30	V		
Excitation Type	DC			
Excitation Current draw	0.5	A		
Calibration Date	1-Nov-2006	CAL		Date of the last calibration or creation of the manufacturing certificate (if no calibration carried out), or of the storage of the TEDS data (if only nominal (rated) values from the data sheet were used). Format: day-month-year. Abbreviations for the months: Jan, Feb, Mar, Apr, May, Jun, Jul, Aug, Sep, Oct, Nov, Dec.
Calibration Initials	HBM or PTB		CAL	Initials of the calibrator or calibration laboratory concerned.
Calibration Period (Days)	0	days	CAL	Time before recalibration, calculated from the date specified under Calibration Date.

Template: Frequency/Pulse Sensor				
Parameter	Value	Unit	Required user rights	Explanation
Measurement location ID	0		USR	Identification number for the measuring point. Can be assigned according to the application. Possible values: a number from 0 to 2047.
Transducer Electrical Signal Type	Pulse Sensor		ID	
Minimum Frequency	0.000E+000	degrees	CAL	The physical measurand and unit are defined when the template is created, after which they cannot be changed.
Maximum Frequency	3.6E+002	degrees	CAL	
Pulse Measurement Type	Count			
Minimum Electrical Value	0.0	Imp	CAL	The difference between these values is the nominal (rated) sensitivity.
Maximum Electrical Value	360	Imp	CAL	
Mapping Method	Linear			
Discrete Signal Type	Bipolar		ID	
Discrete Signal Amplitude	4	V		
Discrete Signal Configuration	Double phase plus zero index			
Transducer Response Time	0	seconds		
Excitation Level nom	24	V		
Excitation Level min	18	V		
Excitation Level max	30	V		
Excitation Type	DC			
Excitation Current draw	0.5	A		
Calibration Date	1-Nov-2006	CAL		Date of the last calibration or creation of the manufacturing certificate (if no calibration carried out), or of the storage of the TEDS data (if only nominal (rated) values from the data sheet were used). Format: day-month-year. Abbreviations for the months: Jan, Feb, Mar, Apr, May, Jun, Jul, Aug, Sep, Oct, Nov, Dec.

Template: Frequency/Pulse Sensor				
Parameter	Value	Unit	Required user rights	Explanation
Calibration Initials	HBM or PTB		CAL	Initials of the calibrator or calibration laboratory concerned.
Calibration Period (Days)	0	days	CAL	Time before recalibration, calculated from the date specified under Calibration Date.
Measurement location ID	0		USR	Identification number for the measuring point. Can be assigned according to the application. Possible values: a number from 0 to 2047.

13 Maintenance

The T12 torque transducer without a rotational speed measuring system is maintenance-free.

Cleaning the rotational speed measuring system

During operation and depending on the ambient conditions, the slotted disc of the rotor and the associated optical system of the stator sensor can get dirty. This becomes noticeable, for example:

- in transducers with a reference pulse, when an increment error is displayed in the “Rotational speed signal” status in the T12 Assistant.
- in transducers without a reference pulse, when there are cyclic intrusions into the rotational speed signal.

Remedy:

1. Use compressed air (up to 6 bar) to clean the slotted disc.
2. Carefully clean the optical system of the sensor with a dry cotton bud or one soaked with pure spirit.

NOTE

Do not use any other solvent to clean the optical system of the sensor! It could alter the optical properties (make plastic cloudy).

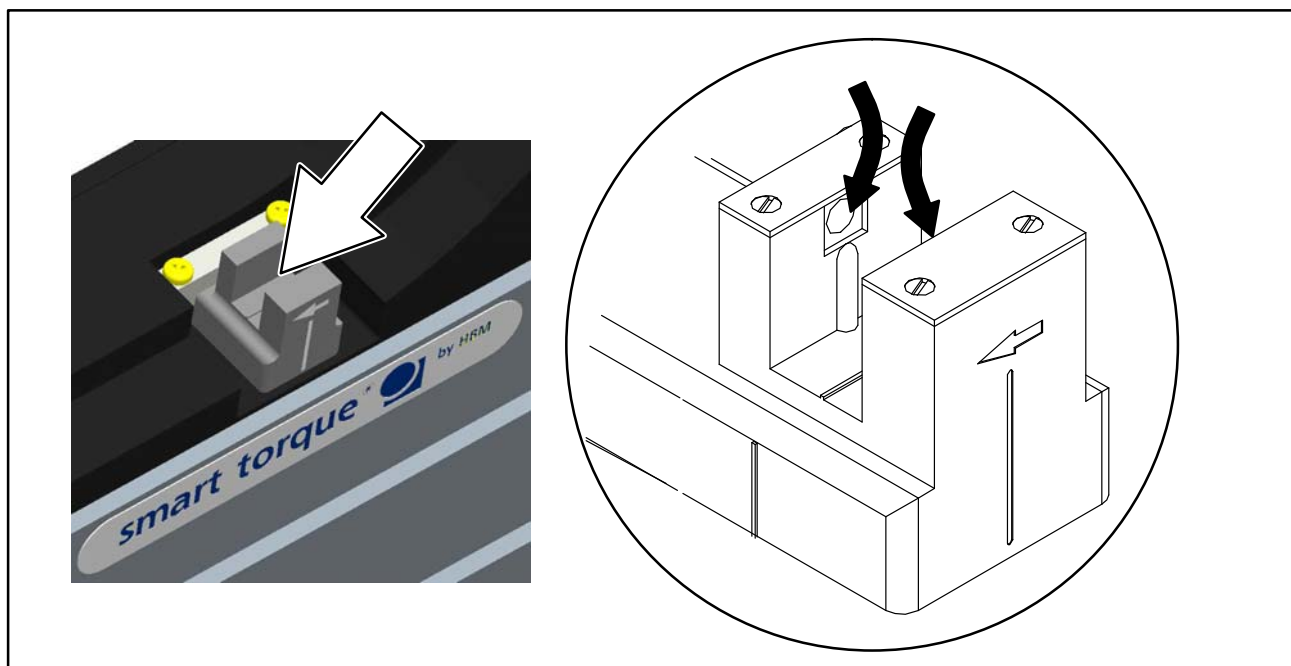
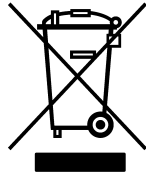

Fig. 12.1: Cleaning points on the rotational speed sensor

14 Waste disposal and environmental protection

All electrical and electronic products must be disposed of as hazardous waste. The correct disposal of old equipment prevents ecological damage and health hazards.



Symbol:

Meaning: **Statutory waste disposal mark**

The electrical and electronic devices that bear this symbol are subject to the European waste electrical and electronic equipment directive 2002/96/EC. The symbol indicates that, in accordance with national and local environmental protection and material recovery and recycling regulations, old devices that can no longer be used must be disposed of separately and not with normal household garbage.

As waste disposal regulations may differ from country to country, we ask that you contact your supplier to determine what type of disposal or recycling is legally applicable in your country.

Packaging

The original packaging of HBM devices is made from recyclable material and can be sent for recycling. Store the packaging for at least the duration of the warranty. In the case of complaints, the torque flange must be returned in the original packaging.

For ecological reasons, empty packaging should not be returned to us.

15 Specifications

15.1 Nominal (rated) torque 100 N·m to 1 kN·m

Type		T12			
Accuracy class		0.03			
Torque measuring system					
Nominal (rated) torque M_{nom}	N·m	100	200	500	
	kN·m				1
Nominal (rated) rotational speed n_{nom} Option 3, code L ¹⁾ Option 3, code H ¹⁾	rpm	15 000		12 000	
	rpm	18 000		16 000	
Non-linearity including hysteresis, related to nominal (rated) sensitivity Fieldbuses, frequency output 10 kHz/60 kHz For a max. torque in the range: between 0% of M_{nom} and 20% of M_{nom} > 20% of M_{nom} and 60% of M_{nom} > 60% of M_{nom} and 100% of M_{nom} Voltage output For a max. torque in the range: between 0% of M_{nom} and 20% of M_{nom} > 20% of M_{nom} and 60% of M_{nom} > 60% of M_{nom} and 100% of M_{nom} Relative standard deviation of repeatability per DIN 1319, related to the variation of the output signal Fieldbuses/frequency output Voltage output	%	< ± 0.006 (optional < ± 0.004)			
	%	< ± 0.013 (optional < ± 0.007)			
	%	< ± 0.02 (optional < ± 0.01)			
	%	< ± 0.015			
	%	< ± 0.035			
	%	< ± 0.05			
Temperature effect per 10 K in the nominal (rated) temperature range on the output signal, related to the actual value of the signal span Fieldbuses/frequency output Voltage output on the zero signal, related to the nominal (rated) sensitivity Fieldbuses/frequency output Voltage output	%	± 0.03			
	%	± 0.1			
	%	± 0.02 (optional ± 0.01)			
	%	± 0.1			
Nominal (rated) sensitivity (span between torque = zero and nominal (rated) torque) Frequency output 10 kHz/60 kHz Voltage output Sensitivity tolerance (deviation of the actual output quantity at M_{nom} from the nominal (rated) sensitivity) Frequency output Voltage output	kHz	5/30			
	V	10			
	%	± 0.05			
	%	± 0.1			
	%	± 0.05			
	%	± 0.1			

¹⁾ See page 87.

Nominal (rated) torque M_{nom}	N·m	100	200	500	
	kN·m				1
Output signal at torque = zero Frequency output 10 kHz/60 kHz Voltage output	kHz V	10/60 0			
Nominal (rated) output signal Frequency output with positive nominal (rated) torque 10 kHz/60 kHz with negative nominal (rated) torque 10 kHz/60 kHz Voltage output with positive nominal (rated) torque with negative nominal (rated) torque	kHz kHz V V	15/90 (5 V symmetrical ²⁾) 5/30 (5 V symmetrical ²⁾) +10 -10			
Scaling range Frequency output/voltage output	%	10 to 1000 (of M_{nom})			
Resolution Frequency output 10 kHz/60 kHz Voltage output	Hz mV	0.03/0.25 0.33			
Residual ripple Voltage output	mV	3			
Maximum modulation range ³⁾ Frequency output 10 kHz/60 kHz Voltage output Load resistance Frequency output Voltage output Long-term drift over 48 h Voltage output	kHz V k Ω k Ω mV	4 to 16/24 to 96 -10.2 to +10.2 ≥ 2 ≥ 10 ± 3			
Measurement frequency range Frequency output/voltage output -1 dB Frequency output/voltage output -3 dB Low-pass filter LP1 Low-pass filter LP2 Group delay (low pass LP1: 4 kHz) Frequency output 10 kHz/60 kHz Voltage output	Hz Hz Hz Hz μ s μ s	0 to 4000 0 to 6000 0.05 to 4000 (fourth-order Bessel, -1 dB); factory setting 1000 Hz 0.05 to 100 (fourth-order Bessel, -1 dB); factory setting 1 Hz 320/250 500			
Energy supply Nominal (rated) supply voltage (DC) (separated extra-low voltage) Current consumption in measuring mode Current consumption in startup mode Nominal (rated) power consumption Maximum cable length	V A A W m	18 to 30 < 1 (typ. 0.5) < 4 < 18 50			
Shunt signal Tolerance of the shunt signal, related to M_{nom}	%	50% of M_{nom} or 10% of M_{nom} ± 0.05			

²⁾ RS-422 complementary signals, note termination resistance.

³⁾ Output signal range in which there is a repeatable correlation between torque and output signal.

Nominal (rated) torque M_{nom}	N·m	100	200	500		
	kN·m				1	
Rotational speed/angle of rotation measuring system Optical, using infrared light and a metallic slotted disc						
Mechanical increments	number	360				
Positional tolerance of the increments	mm	± 0.05				
Tolerance of the slot width	mm	± 0.05				
Pulses per revolution (adjustable)	number	360; 180; 90; 60; 45; 30				
Pulse frequency at nominal (rated) rotational speed n_{nom} Option 3, code L ⁴⁾ Option 3, code H ⁴⁾	kHz	90		72		
	kHz	108		96		
Minimum rotational speed for sufficient pulse quality	rpm	2				
Group delay	µs	< 5 (typ. 2.2)				
Hysteresis of direction of rotation reversal in the case of relative vibrations between rotor and stator						
	Torsional vibration of the rotor	degree	< approx. 2			
	Radial vibrations of the stator	mm	< approx. 2			
Permitted degree of contamination , in the optical path of the sensor pickup (lenses, slotted disc)	%	< 50				
Effect of turbulence on the zero point , related to the nominal (rated) torque						
	Option 3, code L ⁴⁾	%	< 0.05	< 0.03	< 0.03	< 0.02
	Option 3, code H ⁴⁾	%	< 0.08	< 0.04	< 0.03	< 0.02
Output signal for frequency/pulse output	V	5 ⁵⁾ symmetrical; two square-wave signals, approx. 90° out-of-phase				
Load resistance	kΩ	≥ [2]				
Rotational speed						
Fieldbuses						
Resolution	rpm	0.1				
System accuracy (with torsional vibrations of max. 3% of the current rotational speed at 2x rotational frequency)	ppm	150				
Max. rotational speed variation at nominal (rated) rotational speed (100 Hz filter)	rpm	1.5				
Voltage output						
Measuring range	V	± 10				
Resolution	mV	0.33				
Scaling range	%	10 to 1000				
Overload limits	V	± 10.2				
Load resistance	kΩ	> 10				
Linearity error	%	< 0.03				
Nominal (rated) power consumption	W	< 18				
Maximum cable length	m	50				

⁴⁾ See page 87.

⁵⁾ RS-422 complementary signals, note termination resistances.

Nominal (rated) torque M_{nom}	N·m	100	200	500	
	kN·m				1
Temperature effect per 10 K in the nominal (rated) temperature range on the output signal, related to the actual value of the signal span on the zero signal	% %	< 0.03 < 0.03			
Residual ripple	mV	< 3			
Angle of rotation					
Accuracy	degrees	1 (typ. 0.1)			
Resolution	degrees	0.01			
Correction of runtime deviation between torque LP1 and the angle of rotation for filter frequencies	Hz	4000; 2000; 1000; 500; 200; 100			
Measuring range	degrees	0 to 360 (single-turn) to ± 1440 (multi-turn)			
Performance					
Measurement frequency range	Hz	80 (-1 dB)			
Resolution	W	1			
Full scale value	W	$P_{max} = M_{nom} \cdot n_{nom} \cdot \frac{\pi}{30}$ $\frac{[M_{nom}] \text{ in N}\cdot\text{m}}{[n_{nom}] \text{ in rpm}}$			
Temperature effect per 10 K in the nominal (rated) temperature range on the power signal, related to the full scale value	%	$\pm 0.05 \cdot n/n_{nom}$			
Non-linearity including hysteresis, related to the full scale value	%	$\pm 0.02 \cdot n/n_{nom}$			
Sensitivity tolerance (deviation of the actual measurement signal span of the power signal related to the full scale value)	%	± 0.05			
Temperature signal of the rotor					
Accuracy	K	1			
Measurement frequency range	Hz	5 (-1 dB)			
Resolution	K	0.1			
Physical unit	-	°C			
Data rate	Meas. values/s	40			

Fieldbuses		
CAN Bus		
Protocol	–	CAN 2.0B, CAL/CANopen-compatible
Data rate	Meas. values/s	max. 4800 (PDO)
Hardware bus link		as per ISO 11898
Baud rate	kBit/s	1000 500 250 125 100
Maximum line length	m	25 100 250 500 600
Connector	–	5-pin, M12x1, A-coding per CANopen DR-303-1 V1.3, electrically isolated from power supply and measurement ground
PROFIBUS DP		
Protocol	–	PROFIBUS DP Slave, per DIN 19245-3
Baud rate	MBaud	max. 12
PROFIBUS Ident Number	–	096C (hex)
Input data , max.	bytes	152
Output data, max.	bytes	40
Diagnostic data	bytes	18 (2 · 4-byte module diagnosis)
Connector	–	5-pin, M12x1, B-coding, electrically isolated from power supply and measurement ground
Update rate ⁶⁾		
Configuration entries ≤ 2		4800
≤ 4		2400
≤ 8	Meas. values/s	1200
≤ 12		600
≤ 16		300
> 16		150
Limit value switches (on fieldbuses only)		
Number	–	4 for torque, 4 for rotational speed
Reference level	–	Torque low pass 1 or low pass 2 Rotational speed low pass1 or low pass 2
Hysteresis	%	0 to 100
Adjustment accuracy	digits	1
Response time (LP1 = 4000 Hz)	ms	typ. 3
TEDS (Transducer Electronic Data Sheet)		
Number	–	2
TEDS 1 (torque)	–	A choice of voltage sensor or frequency sensor
TEDS 2 (rotational speed/angle of rotation)	–	Frequency/pulse sensor

⁶⁾ When CAN PDOs are activated simultaneously, the update rate on the PROFIBUS is reduced.

Nominal (rated) torque M_{nom}	N·m	100	200	500	
	kN·m				1
General information					
EMC					
Emission (per FCC 47 Part 15, Subpart C)	–				
Emission (per EN61326–1, Table 3)					
RFI voltage	–	Class A			
RFI power	–	Class A			
RFI field strength	–	Class A			
Immunity from interference (EN61326–1, Table A.1)					
Electromagnetic field (AM)	V/m	10			
Magnetic field	A/m	30			
Electrostatic discharge (ESD)					
Contact discharge	kV	4			
Air discharge	kV	8			
Fast transients (burst)	kV	1			
Impulse voltages (surge)	kV	1			
Conducted interference (AM)	V	3			
Degree of protection per EN 60529		IP 54			
Reference temperature	°C	23			
Nominal (rated) temperature range	°C	+10 to +60			
Operating temperature range	°C	–10 to +60			
Storage temperature range	°C	–20 to +70			
Impact resistance, test severity level according to DIN IEC 68; Part 227; IEC 682271987					
Number	n	1000			
Duration	ms	3			
Acceleration (half sine)	m/s ²	650			
Vibration in 3 directions according to EN 60068–2–6: IEC 68-2-6-1982					
Frequency range	Hz	5 to 65			
Duration	h	1.5			
Acceleration (amplitude)	m/s ²	50			
Load limits⁷⁾					
Limit torque, (static) ±	% of M_{nom}	200			
Breaking torque, (static) ±	% of M_{nom}	> 400			
Longitudinal limit force (static) ±	kN	5	10	16	19
Longitudinal limit force (dynamic) amplitude	kN	2.5	5	8	8.5
Lateral limit force (static) ±	kN	1	2	4	5
Lateral limit force (dynamic) amplitude	kN	0.5	1	2	2.5
Limit bending moment (static) ±	N·m	50	100	200	220
Limit bending moment (dynamic) amplitude	N·m	25	50	100	110
Oscillation width per DIN 50100 (peak-to-peak)⁸⁾	N·m	200	400	1000	2000

⁷⁾ Each type of irregular stress (bending moment, lateral or longitudinal force, exceeding nominal (rated) torque) can only be permitted up to its specified limit provided none of the others can occur at the same time. If this condition is not met, the limit values must be reduced. If 30% of the limit bending moment and lateral limit force occur at the same time, only 40% of the longitudinal limit force is permissible and the nominal (rated) torque must not be exceeded. The effects of permissible bending moments, longitudinal and lateral forces on the measurement result are $\leq \pm 0.3\%$ of the nominal (rated) torque.

⁸⁾ The nominal (rated) torque must not be exceeded.

Nominal (rated) torque M_{nom}	N·m	100	200	500	
	kN·m				1
Mechanical values					
Torsional stiffness c_T	kN·m/ rad	230	270	540	900
Torsion angle at M_{nom}	degree s	0.048	0.043	0.055	0.066
Stiffness in the axial direction c_a	kN/mm	420	800	740	760
Stiffness in the radial direction c_r	kN/mm	130	290	550	810
Stiffness during the bending moment round a radial axis c_b	kN·m/ degree s	3.8	7	11.5	12
Maximum deflection at longitudinal limit force	mm	< 0.02		< 0.03	
Additional max. radial deviation at lateral limit force	mm	< 0.02			
Additional plumb/parallel deviation at limit bending moment (at $\varnothing d_B$)	mm	< 0.03		< 0.05	
Balance quality level per DIN ISO 1940		G 2.5			
Max. limits for relative shaft vibration (peak-to-peak) ⁹⁾ Undulations in the connection flange area, based on ISO 7919-3	μm	Normal operation (continuous operation) $s_{(p-p)} = \frac{9000}{\sqrt{n}}$ Start and stop operation, resonance ranges (temp.) $s_{(p-p)} = \frac{13200}{\sqrt{n}}$ (n in rpm)			
Mass moment of inertia of the rotor I_V (around rotary axis)	kg·m ²	0.0023	0.0033	0.0059	
I_V with optical rotational speed measuring system	kg·m ²	0.0025	0.0035	0.0062	
Proportional mass moment of inertia for the transmitter side without rotational speed measuring system	%	58		56	
with optical rotational speed measuring system	%	56		54	
Max. permissible static eccentricity of the rotor (radially) to the center point of the stator without rotational speed measuring system	mm	± 2			
with rotational speed measuring system	mm	± 1			
Max. permissible axial displacement of the rotor to the stator	mm	± 2			
Weight, approx. Rotor	kg	1.1	1.8	2.4	
Stator	kg	2.3			

⁹⁾ The influence of radial deviations, impact, defects of form, notches, marks, local residual magnetism, structural variations or material anomalies on the vibrational measurements needs to be taken into account and isolated from the actual undulation.

15.2 Nominal (rated) torque 2 kN·m to 10 kN·m

Type		T12			
Accuracy class		0.03			
Torque measuring system					
Nominal (rated) torque M_{nom}	kN·m	2	3	5	10
Nominal (rated) rotational speed n_{nom} Option 3, code L ¹⁾ Option 3, code H ¹⁾	rpm	12 000		10 000	
	rpm	16 000		14 000	12 000
Non-linearity including hysteresis , related to nominal (rated) sensitivity Fieldbuses, frequency output 10 kHz/60 kHz For a max. torque in the range: between 0% of M_{nom} and 20% of M_{nom} > 20% of M_{nom} and 60% of M_{nom} > 60% of M_{nom} and 100% of M_{nom} Voltage output For a max. torque in the range: between 0% of M_{nom} and 20% of M_{nom} > 20% of M_{nom} and 60% of M_{nom} > 60% of M_{nom} and 100% of M_{nom} Relative standard deviation of repeatability per DIN 1319, related to the variation of the output signal Fieldbuses/frequency output Voltage output		%	< ± 0.006 (optional < ± 0.004)		
	%	< ± 0.013 (optional < ± 0.007)			
	%	< ± 0.02 (optional < ± 0.01)			
	%	< ± 0.015			
	%	< ± 0.035			
	%	< ± 0.05			
Temperature effect per 10 K in the nominal (rated) temperature range on the output signal, related to the actual value of the signal span Fieldbuses/frequency output Voltage output on the zero signal, related to the nominal (rated) sensitivity Fieldbuses/frequency output Voltage output		%	± 0.03		
	%	± 0.1			
	%	± 0.02 (optional ± 0.01)			
	%	± 0.1			
Nominal (rated) sensitivity (span between torque = zero and nominal (rated) torque) Frequency output 10 kHz/60 kHz Voltage output Sensitivity tolerance (deviation of the actual output quantity at M_{nom} from the nominal (rated) sensitivity) Frequency output Voltage output		kHz	5/30		
	V	10			
	%	± 0.05			
	%	± 0.1			

¹⁾ See page 87.

Nominal (rated) torque M_{nom}	kN·m	2	3	5	10
Output signal at torque = zero Frequency output 10 kHz/60 kHz Voltage output	kHz V		10/60 0		
Nominal (rated) output signal Frequency output with positive nominal (rated) torque 10 kHz/60 kHz with negative nominal (rated) torque 10 kHz/60 kHz Voltage output with positive nominal (rated) torque with negative nominal (rated) torque	kHz kHz V V		15/90 (5 V symmetrical ²⁾) 5/30 (5 V symmetrical ²⁾) +10 -10		
Scaling range Frequency output/voltage output	%		10 to 1000 (of M_{nom})		
Resolution Frequency output 10 kHz/60 kHz Voltage output	Hz mV		0.03/0.25 0.33		
Residual ripple Voltage output	mV		3		
Maximum modulation range ³⁾ Frequency output 10 kHz/60 kHz Voltage output Load resistance Frequency output Voltage output Long-term drift over 48 h Voltage output	kHz V kΩ kΩ mV		4 to 16/24 0 96 -10.2 to +10.2 ≥ 2 ≥ 10 ± 3		
Measurement frequency range Frequency output/voltage output -1 dB Frequency output/voltage output -3 dB Low-pass filter LP1 Low-pass filter LP2 Group delay (low-pass LP1: 4 kHz) Frequency output 10 kHz/60 kHz Voltage output	Hz Hz Hz Hz μs μs		0 to 4000 0 to 6000 0.05 to 4000 (fourth-order Bessel, -1 dB); factory setting 1000 Hz 0.05 to 100 (fourth-order Bessel, -1 dB); factory setting 1 Hz 320/250 500		
Energy supply Nominal (rated) supply voltage (DC) (separated extra-low voltage) Current consumption in measuring mode Current consumption in startup mode Nominal (rated) power consumption Maximum cable length	V A A W m		18 to 30 < 1 (typ. 0.5) < 4 < 18 50		
Shunt signal Tolerance of the shunt signal, related to M_{nom}	%		50% of M_{nom} or 10% of M_{nom} ± 0.05		

²⁾ RS-422 complementary signals, note termination resistance.

³⁾ Output signal range in which there is a repeatable correlation between torque and output signal.

Nominal (rated) torque M_{nom}	kN·m	2	3	5	10
Rotational speed/angle of rotation measuring system Optical, using infrared light and a metallic slotted disc					
Mechanical increments	number	360		720	
Positional tolerance of the increments	mm	± 0.05			
Tolerance of the slot width	mm	± 0.05			
Pulses per revolution (adjustable)	number	360; 180; 90; 60; 45; 30		720; 360; 180; 120; 90; 60	
Pulse frequency at nominal (rated) rotational speed n_{nom} Option 3, code L ⁴⁾ Option 3, code H ⁴⁾	kHz	72		120	
	kHz	96		168	
Minimum rotational speed for sufficient pulse quality	rpm	2			
Group delay	µs	< 5 (typ. 2.2)			
Hysteresis of direction of rotation reversal in the case of relative vibrations between rotor and stator Torsional vibration of the rotor Radial vibrations of the stator	degrees	< approx. 2			
	mm	< approx. 2			
Permitted degree of contamination , in the optical path of the sensor pickup (lenses, slotted disc)	%	< 50			
Effect of turbulence on the zero point , related to the nominal (rated) torque Option 3, code L ⁴⁾ Option 3, code H ⁴⁾	%	< 0.02		< 0.01	
	%	< 0.02		< 0.01	
Output signal for frequency/pulse output	V	5 ⁵⁾ symmetrical; two square-wave signals, approx. 90° out-of-phase			
Load resistance	kΩ	≥ 2			
Rotational speed					
Fieldbuses					
Resolution	rpm	0.1			
System accuracy (with torsional vibrations of max. 3% of the current rotational speed at 2x rotational frequency)	ppm	150			
Max. rotational speed variation at nominal (rated) rotational speed (100 Hz filter)	rpm	1.5			
Voltage output					
Measuring range	V	± 10			
Resolution	mV	0.33			
Scaling range	%	10 to 1000			
Overload limits	V	± 10.2			
Load resistance	kΩ	> 10			
Linearity error	%	< 0.03			
Nominal (rated) power consumption	W	< 18			
Maximum cable length	m	50			

⁴⁾ See page 87.

⁵⁾ RS-422 complementary signals, note termination resistances.

Nominal (rated) torque M_{nom}	kN·m	2	3	5	10
Temperature effect per 10 K in the nominal (rated) temperature range on the output signal, related to the actual value of the signal span	%		< 0.03		
on the zero signal	%		< 0.03		
Residual ripple	mV		< 3		
Angle of rotation					
Accuracy	degree s		1 (typ. 0.1)		
Resolution	degree s		0.01		
Correction of runtime deviation between torque LP1 and the angle of rotation for filter frequencies	Hz		4000; 2000; 1000; 500; 200; 100		
Measuring range	degree s		0 to 360 (single-turn) to ± 1440 (multi-turn)		
Performance					
Measurement frequency range	Hz		80 (-1 dB)		
Resolution	W		1		
Full scale value	W		$P_{max} = M_{nom} \cdot n_{nom} \cdot \frac{\pi}{30}$		$\frac{[M_{nom}] \text{ in N}\cdot\text{m}}{[n_{nom}] \text{ in rpm}}$
Temperature effect per 10 K in the nominal (rated) temperature range on the power signal, related to the full scale value	%		$\pm 0.05 \cdot n/n_{nom}$		
Non-linearity including hysteresis, related to the full scale value	%		$\pm 0.02 \cdot n/n_{nom}$		
Sensitivity tolerance (deviation of the actual measurement signal span of the power signal related to the full scale value)	%		± 0.05		
Temperature signal of the rotor					
Accuracy	K		1		
Measurement frequency range	Hz		5 (-1 dB)		
Resolution	K		0.1		
Physical unit	-		$^{\circ}\text{C}$		
Data rate	Meas. values/ s		40		

Fieldbuses		
CAN Bus		
Protocol	–	CAN 2.0B, CAL/CANopen-compatible
Data rate	Meas. values/s	max. 4800 (PDO)
Hardware bus link		as per ISO 11898
Baud rate	kBit/s	1000 500 250 125 100
Maximum line length	m	25 100 250 500 600
Connector	–	5-pin, M12x1, A-coding per CANopen DR-303-1 V1.3, electrically isolated from power supply and measurement ground
PROFIBUS DP		
Protocol	–	PROFIBUS DP Slave, per DIN 19245-3
Baud rate	MBaud	max. 12
PROFIBUS Ident Number	–	096C (hex)
Input data , max.	bytes	152
Output data, max.	bytes	40
Diagnostic data	bytes	18 (2 · 4-byte module diagnosis)
Connector	–	5-pin, M12x1, B-coding, electrically isolated from power supply and measurement ground
Update rate ⁶⁾		
Configuration entries ≤ 2		4800
≤ 4		2400
≤ 8	Meas. values/s	1200
≤ 12		600
≤ 16		300
> 16		150
Limit value switches (on fieldbuses only)		
Number	–	4 for torque, 4 for rotational speed
Reference level	–	Torque low pass 1 or low pass 2 Rotational speed low pass1 or low pass 2
Hysteresis	%	0 to 100
Adjustment accuracy	digits	1
Response time (LP1 = 4000 Hz)	ms	typ. 3
TEDS (Transducer Electronic Data Sheet)		
Number	–	2
TEDS 1 (torque)	–	A choice of voltage sensor or frequency sensor
TEDS 2 (rotational speed/angle of rotation)	–	Frequency/pulse sensor

⁶⁾ When CAN PDOs are activated simultaneously, the update rate on the PROFIBUS is reduced.

Nominal (rated) torque M_{nom}	kN·m	2	3	5	10
General information					
EMC					
Emission (per EN61326-1, Table 3)					
RFI voltage	–			Class A	
RFI power	–			Class A	
RFI field strength	–			Class A	
Immunity from interference (EN61326-1, Table A.1)					
Electromagnetic field (AM)	V/m		10		
Magnetic field	A/m		30		
Electrostatic discharge (ESD)					
Contact discharge	kV		4		
Air discharge	kV		8		
Fast transients (burst)	kV		1		
Impulse voltages (surge)	kV		1		
Conducted interference (AM)	V		3		
Degree of protection per EN 60529					
			IP 54		
Reference temperature					
	°C	23			
Nominal (rated) temperature range					
	°C	+10 to +60			
Operating temperature range					
	°C	–10 to +60			
Storage temperature range					
	°C	–20 to +70			
Impact resistance, test severity level according to DIN IEC 68; Part 227; IEC 682271987					
Number	n	1000			
Duration	ms	3			
Acceleration (half sine)	m/s ²	650			
Vibration in 3 directions according to EN 60068-2-6: IEC 68-2-6-1982					
Frequency range	Hz	5 to 65			
Duration	h	1.5			
Acceleration (amplitude)	m/s ²	50			50
Load limits⁷⁾					
Limit torque, (static) ±	% of M_{nom}	200		160	
Breaking torque, (static) ±	% of M_{nom}	> 400		> 320	
Longitudinal limit force (static) ±	kN	39	42	80	120
Longitudinal limit force (dynamic) amplitude	kN	19.5	21	40	60
Lateral limit force (static) ±	kN	9	10	12	18
Lateral limit force (dynamic) amplitude	kN	4.5	5	6	9
Limit bending moment (static) ±	N·m	560	600	800	1200
Limit bending moment (dynamic) amplitude	N·m	280	300	400	600
Oscillation width per DIN 50100 (peak-to-peak)⁸⁾	N·m	4000	4800	8000	16000

⁷⁾ Each type of irregular stress (bending moment, lateral or longitudinal force, exceeding nominal (rated) torque) can only be permitted up to its specified limit provided none of the others can occur at the same time. If this condition is not met, the limit values must be reduced. If 30% of the limit bending moment and lateral limit force occur at the same time, only 40% of the longitudinal limit force is permissible and the nominal (rated) torque must not be exceeded. The effects of permissible bending moments, longitudinal and lateral forces on the measurement result are $\leq \pm 0.3\%$ of the nominal (rated) torque.

⁸⁾ The nominal (rated) torque must not be exceeded.

Nominal (rated) torque M_{nom}	kN·m	2	3	5	10
Mechanical values					
Torsional stiffness c_T	kN·m/ rad	2300	2600	4600	7900
Torsion angle at M_{nom}	degrees	0.049	0.066	0.06	0.07
Stiffness in the axial direction c_a	kN/mm	950	1000	950	1600
Stiffness in the radial direction c_r	kN/mm	1300	1500	1650	2450
Stiffness during the bending moment round a radial axis c_b	kN·m/ degrees	21.7	22.4	43	74
Maximum deflection at longitudinal limit force	mm	< 0.05		< 0.1	
Additional max. radial deviation at lateral limit force	mm	< 0.02			
Additional plumb/parallel deviation at limit bending moment (at $\varnothing d_B$)	mm	< 0.07			
Balance quality level per DIN ISO 1940		G 2.5			
Max. limits for relative shaft vibration (peak-to-peak) ⁹⁾ Undulations in the connection flange area, based on ISO 7919-3	μm	Normal operation (continuous operation) $s_{(p-p)} = \frac{9000}{\sqrt{n}}$ Start and stop operation, resonance ranges (temp.) $s_{(p-p)} = \frac{13200}{\sqrt{n}}$ (n in rpm)			
Mass moment of inertia of the rotor I_V (around rotary axis)	kg·m ²	0.0192	0.037	0.097	
I_V with optical rotational speed measuring system	kg·m ²	0.0196	0.038	0.0995	
Proportional mass moment of inertia for the transmitter side without rotational speed measuring system	%	54	53		
with optical rotational speed measuring system	%	53	52		
Max. permissible static eccentricity of the rotor (radially) to the center point of the stator without rotational speed measuring system	mm	± 2			
with rotational speed measuring system	mm	± 1			
Max. permissible axial displacement of the rotor to the stator	mm	± 2			
Weight, approx. Rotor	kg	4.9	8.3	14.6	
Stator	kg	2.4	2.5	2.6	

⁹⁾ The influence of radial deviations, impact, defects of form, notches, marks, local residual magnetism, structural variations or material anomalies on the vibrational measurements needs to be taken into account and isolated from the actual undulation.

16 Dimensions

16.1 Rotor 100 N·m to 200 N·m

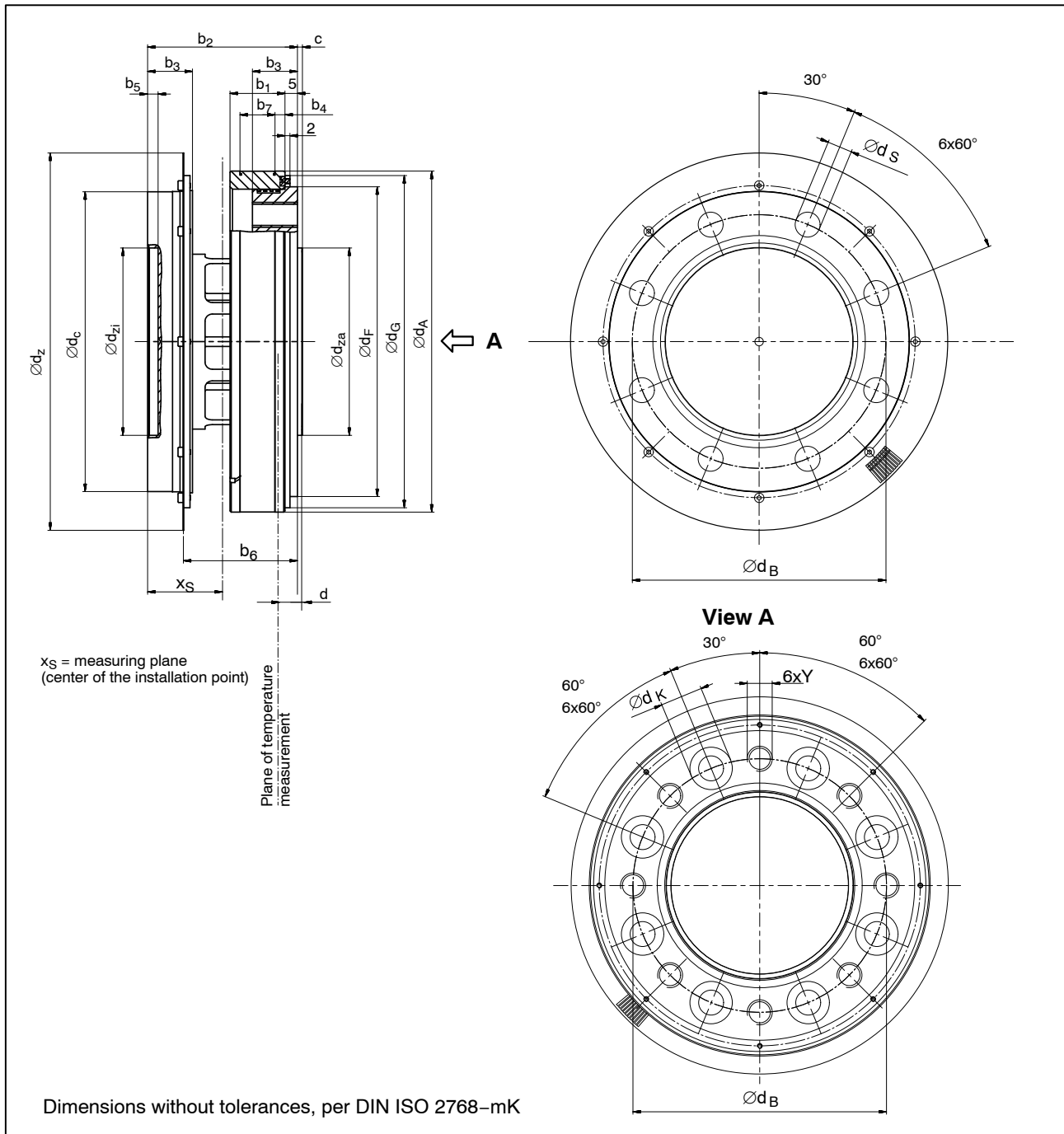

Measuring range	Dimensions in mm (1 mm = 0.03937 inches)										
	b ₁	b ₂	b ₃	b ₄	b ₅	b ₆	b ₇	c	d	x _S	Y
100 N·m/200 N·m	22	60	18	4	4	47.15	14	2	12.5	30	M8

Measuring range	Dimensions in mm (1 mm = 0.03937 inches)									
	Ød _A	Ød _B	Ød _C	Ød _F	Ød _G	Ød _K	Ød _S ^{C12}	Ød _Z	Ød _{za g5}	Ød _{zi} ^{H6}
100 N·m/200 N·m	115.5	84	99	101	110	14	8.2	131	57	57

16.2 Rotor 500 N·m to 10 kN·m

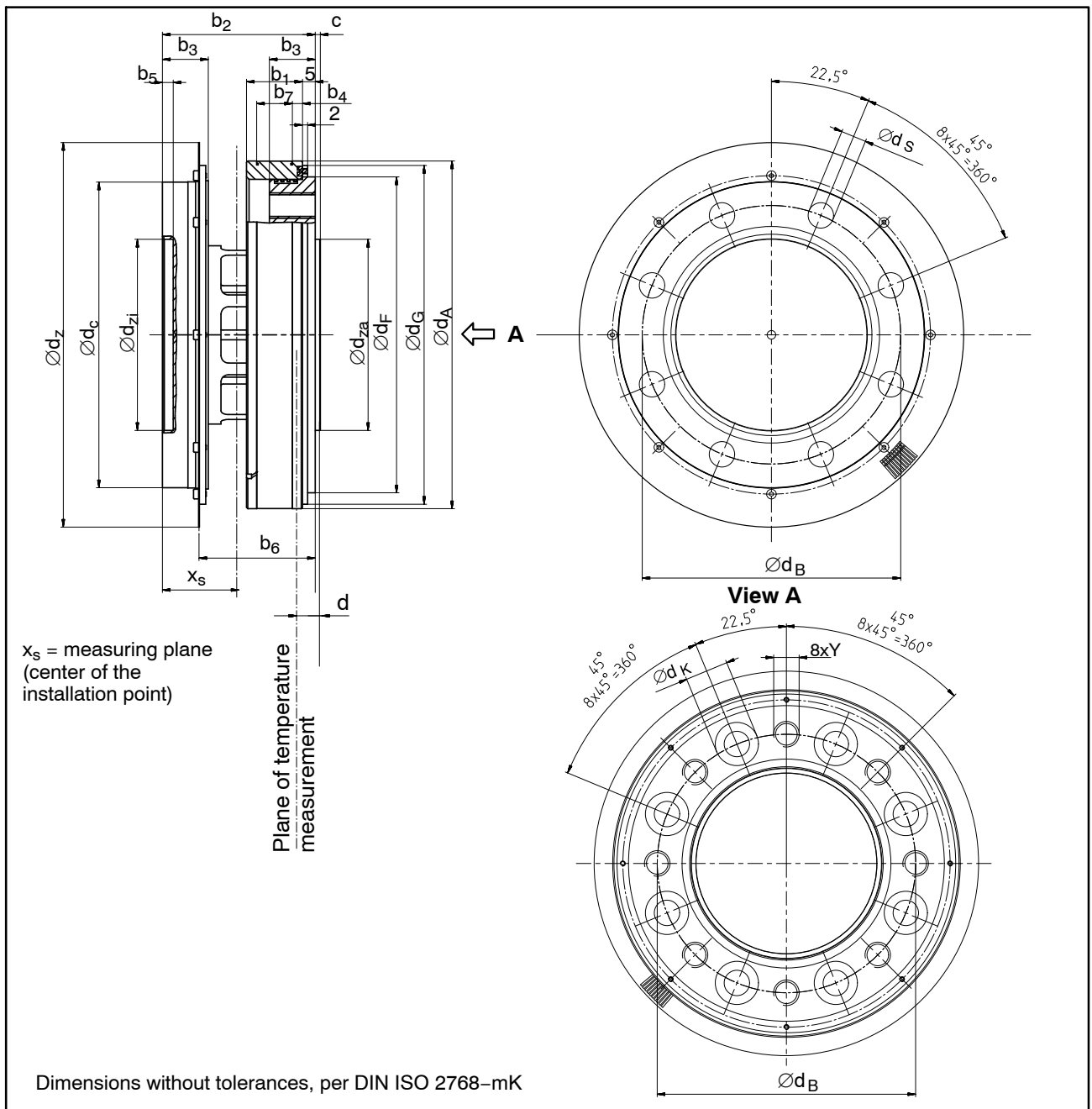

Measuring range	Dimensions in mm (1 mm = 0.03937 inches)										
	b_1	b_2	b_3	b_4	b_5	b_6	b_7	c	d	x_s	Y
500 N·m/1 kN·m	22	60	18	4	4	45.7	14	2	8	30	M10
2 kN·m/3 kN·m	23	64	20	5	4	47.7	14	2.5	8	32	M12
5 kN·m	24.8	84	26	3.3	3	62.7	17.5	2.8	8	42	M14
10 kN·m	24.8	92	30	3.3	4	66.7	17.5	3.5	10	46	M16

Measuring range	Dimensions in mm (1 mm = 0.03937 inches)									
	$\varnothing d_A$	$\varnothing d_B$	$\varnothing d_C$	$\varnothing d_F$	$\varnothing d_G$	$\varnothing d_K$	$\varnothing d_S^{C12}$	$\varnothing d_Z$	$\varnothing d_{za\ g5}$	$\varnothing d_{zi}^{H6}$
500 N·m/1 kN·m	136.5	101.5	120	124	133	17	10	151	75	75
2 kN·m/3 kN·m	172.5	130	155	160	169	19	12	187	90	90
5 kN·m	200.5	155.5	179	188	197	22	14.2	221	110	110
10 kN·m	242.5	196	221	230	239	26	17	269	140	140

16.3 Stator 100 N·m to 200 N·m with rot.speed meas. system

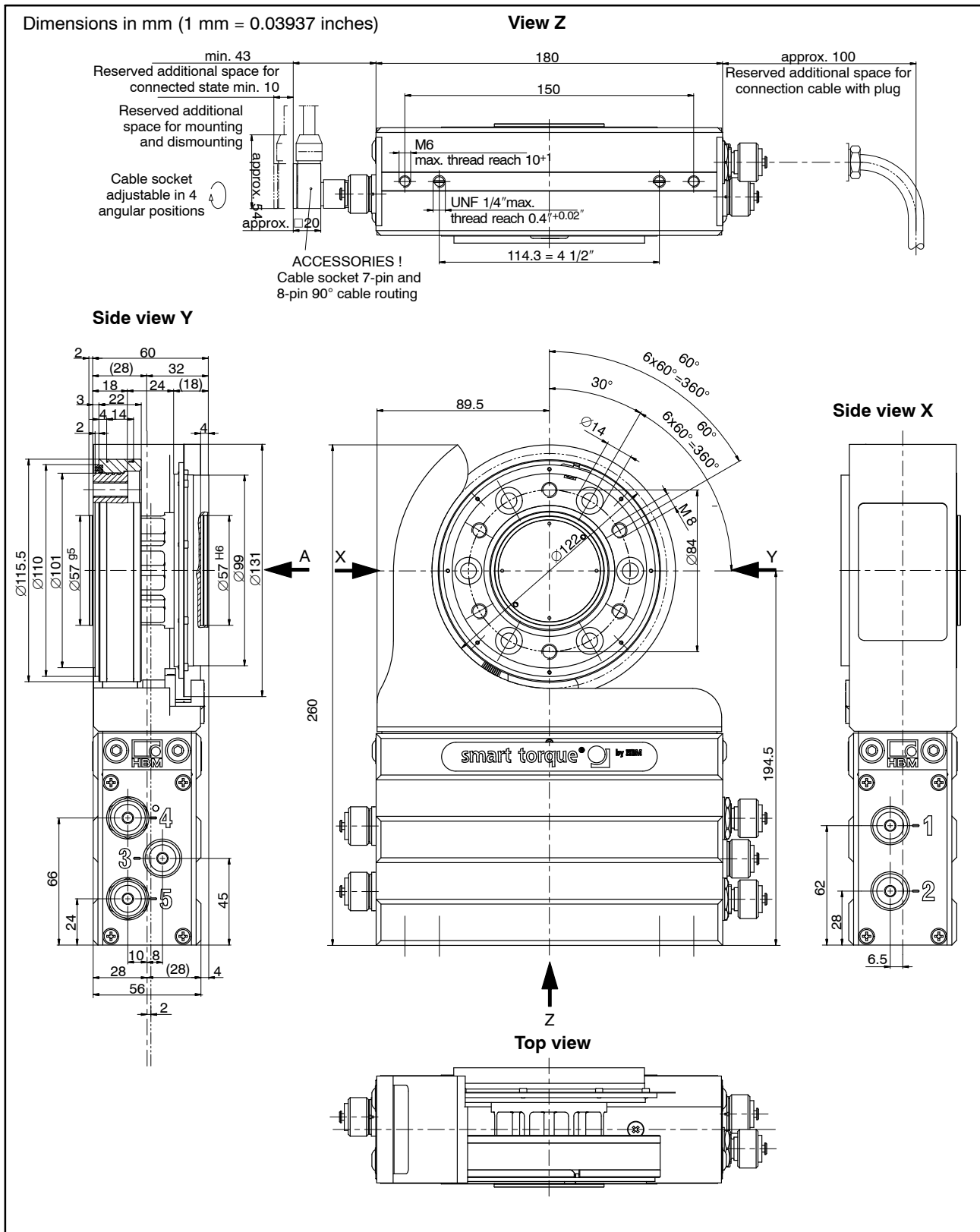

16.4 Stator 100 N·m to 200 N·m with rot. speed meas. system

Dimensions in mm (1 mm = 0.03937 inches)

View A

For rotational speed
measuring system and
rotational speed
measuring system with
reference marker only

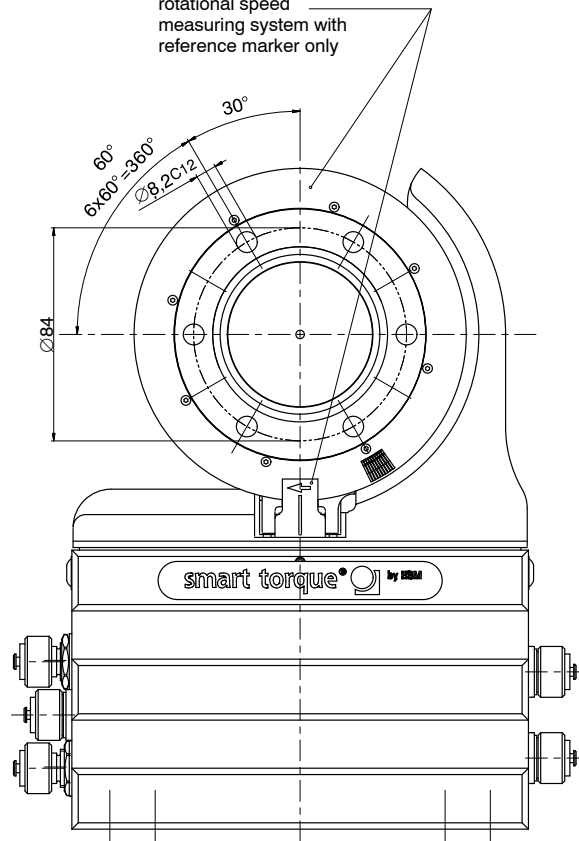

16.5 Stator 100 N·m to 10 kN·m with rot. speed meas. system

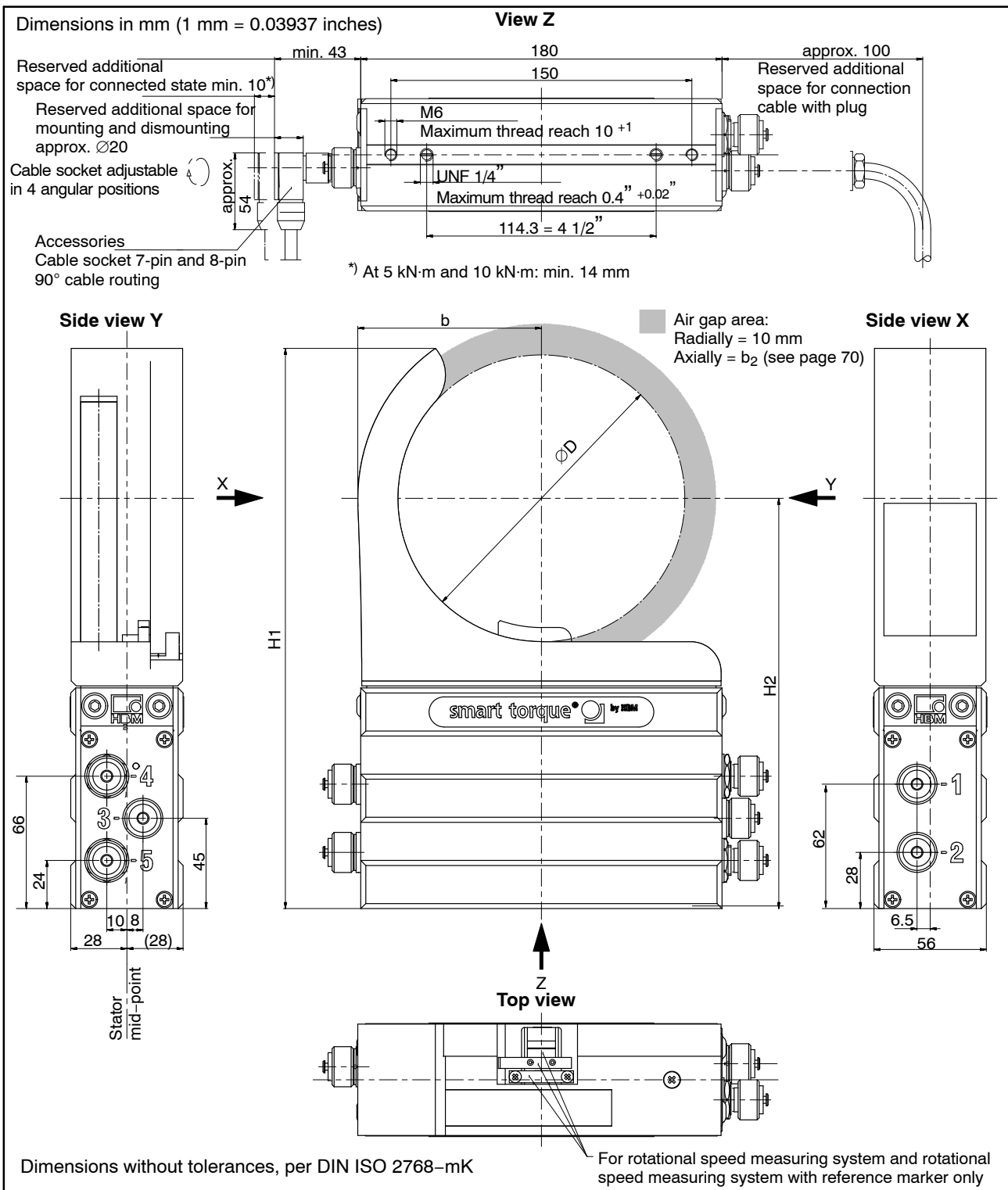

Measuring range (N·m)	Dimensions in mm (1 mm = 0.03937 inches)			
	b	ØD	H1	H2
100	81	122	260	194.5
200				
500	91.5	143	280	204.5
1 k				
2 k	109.5	179	310	222.5
3 k				
5 k	123.5	207	333	239.5
10 k	144.5	249	369	263.5

16.6 Stator 100 N·m to 200 N·m with prot. against contact

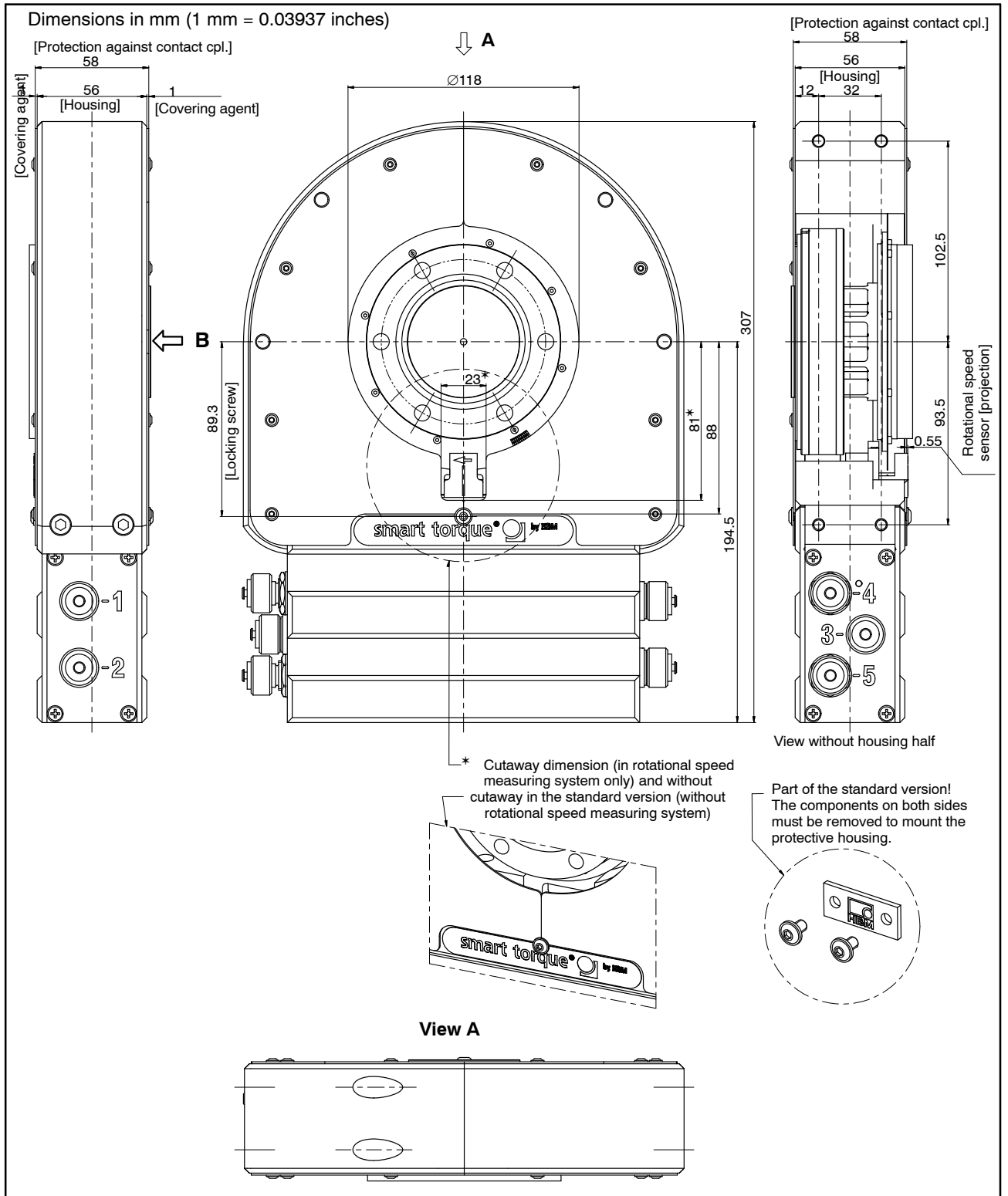

16.7 Stator 100 N·m to 200 N·m with prot. against contact

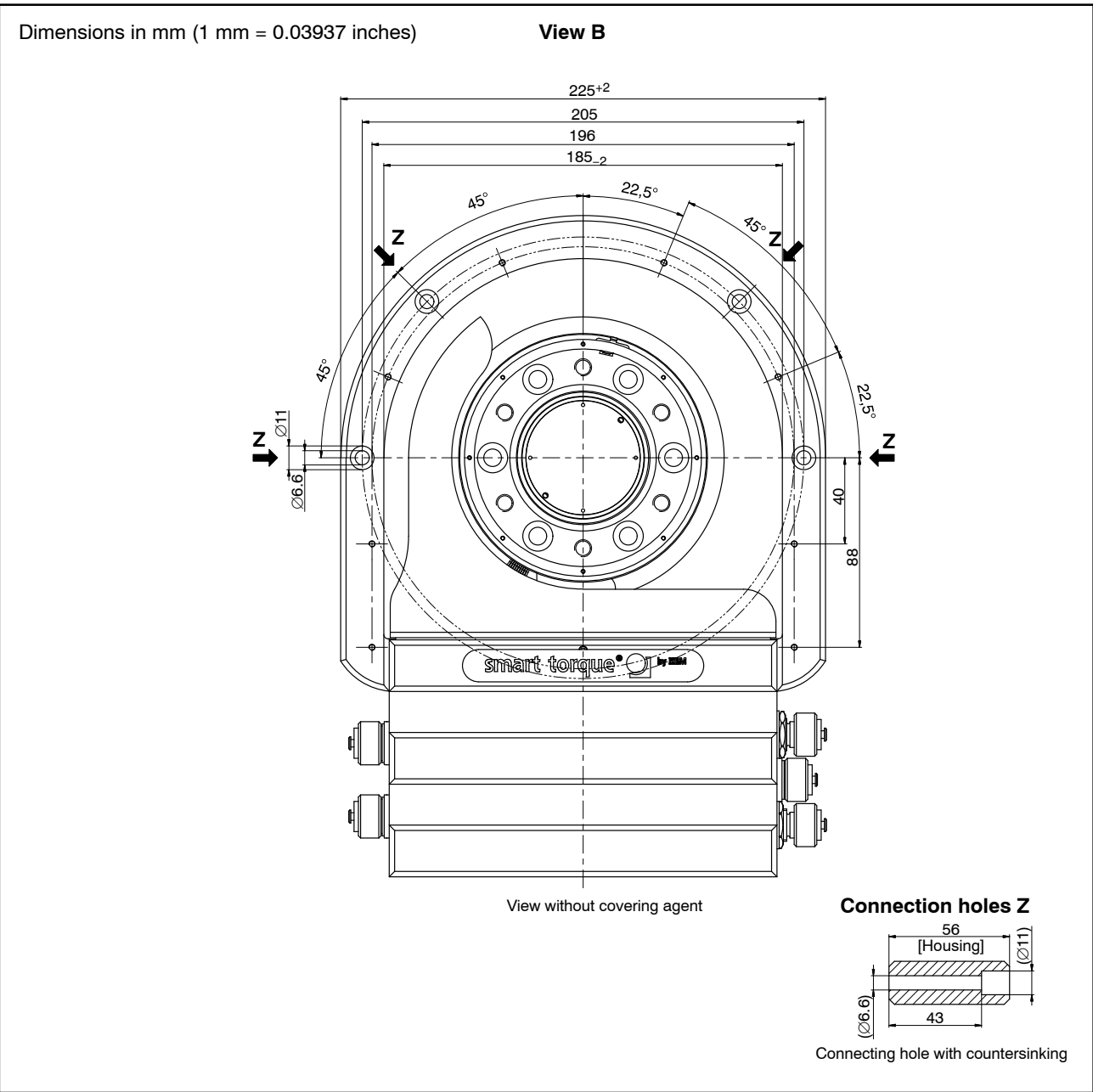

16.8 Stator 500 N·m to 1 kN·m with prot. against contact

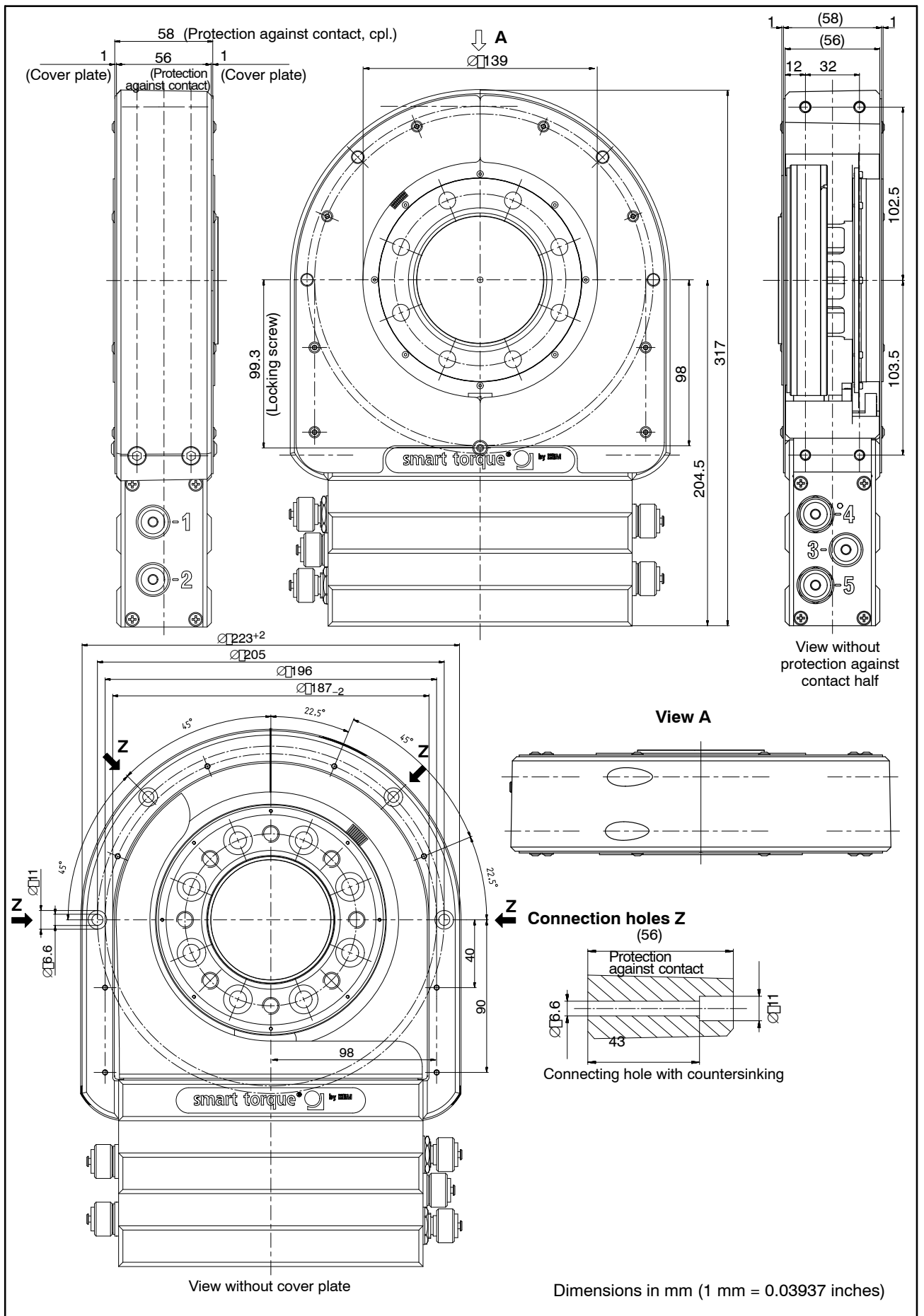

16.9 Stator 2 kN·m to 10 kN·m with prot. against contact

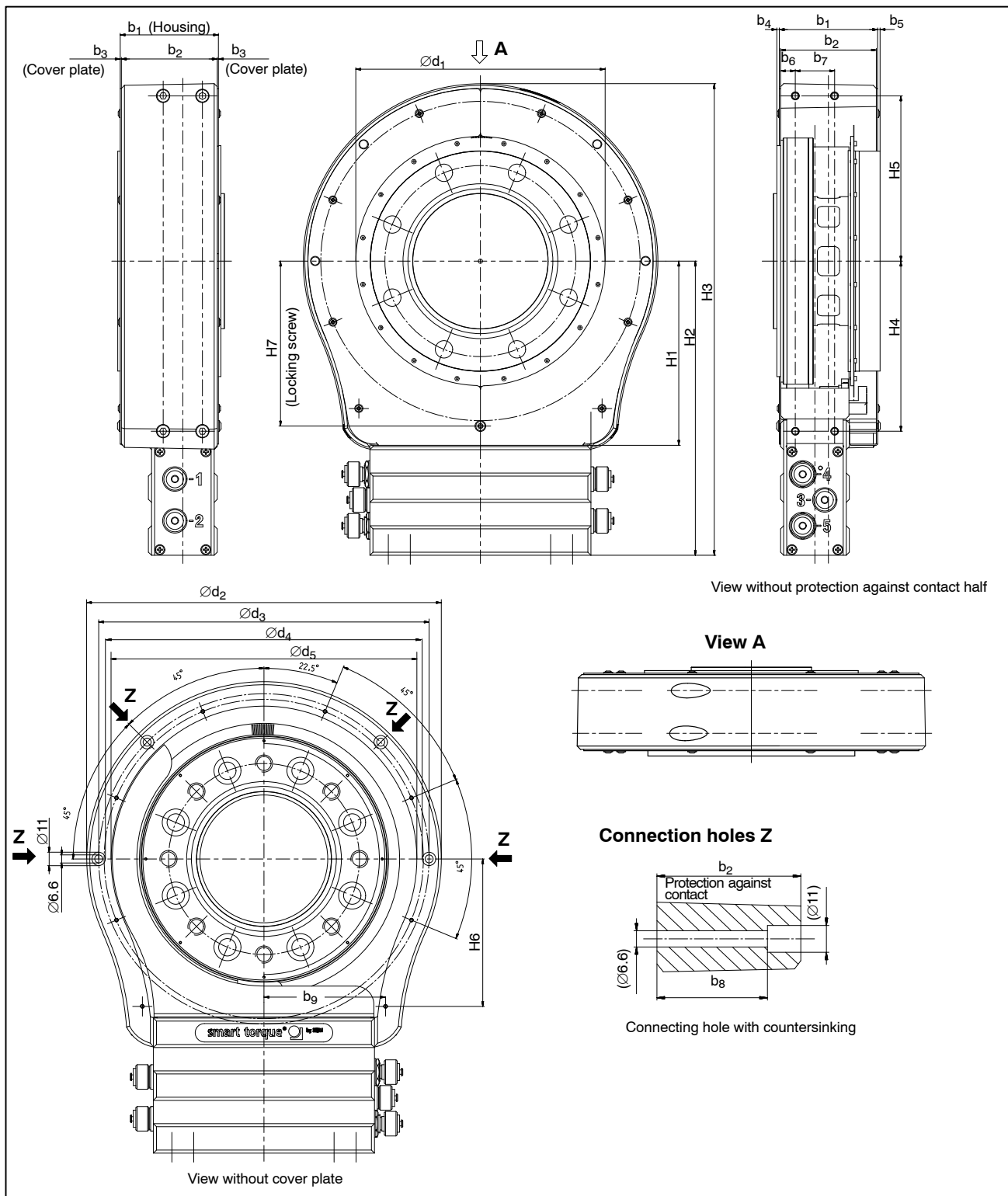

Measuring range	Dimensions in mm (1 mm = 0.03937 inches)															
	b ₁	b ₂	b ₃	b ₄	b ₅	b ₆	b ₇	b ₈	b ₉	H ₁	H ₂	H ₃	H ₄	H ₅	H ₇	
2 kN·m/3 kN·m	58	56	1	2	4	12	32	43	97.5	116	222.5	353	121.5	107	120.5	117.3
5 kN·m	80	78	1	2	2	12	32	65	99	133	239.5	384	138.5	120	134.5	134.3
10 kN·m	88	86	1	2	2	12	32	73	99	157	263.5	429	162.5	145	155.5	158.3

Measuring range	Dimensions in mm (1 mm = 0.03937 inches)				
	Ød ₁	Ød ₂	Ød ₃	Ød ₄	Ød ₅
2 kN·m/3 kN·m	175	259 ⁺²	241	232	223 ₋₂
5 kN·m	203	289 ⁺²	269	260	249 ₋₂
10 kN·m	245	331 ⁺²	311	302	291 ₋₂

16.9.1 Protection against contact plates 100 N·m to 200 N·m

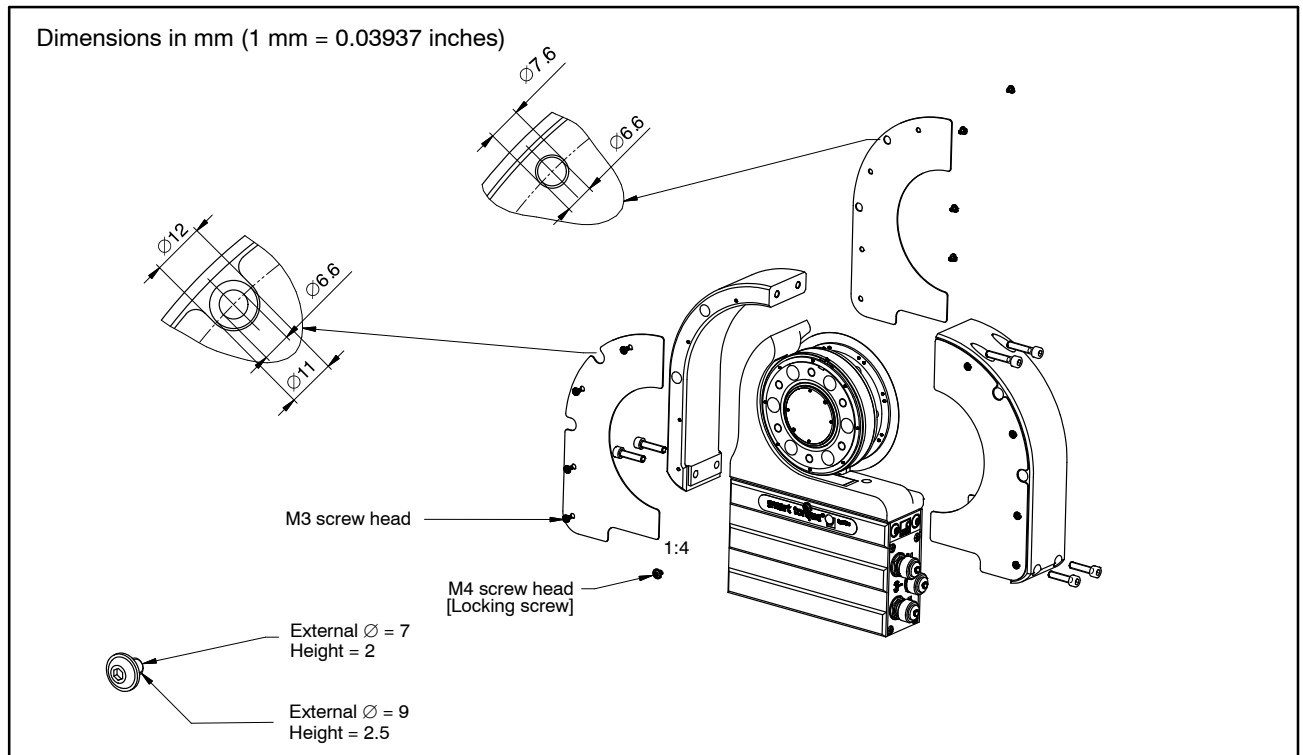

16.9.2 Protection against contact plates 500 N·m to 10 kN·m

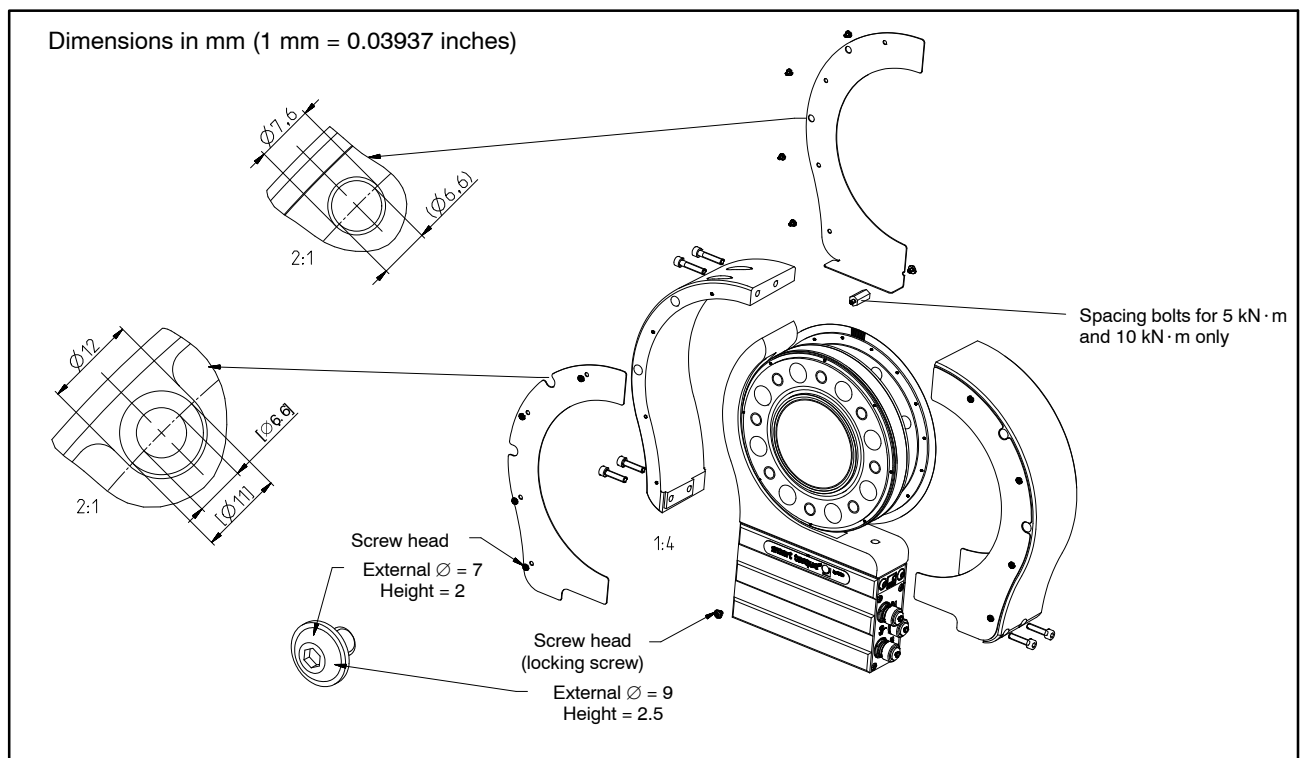

16.10 Mounting dimensions

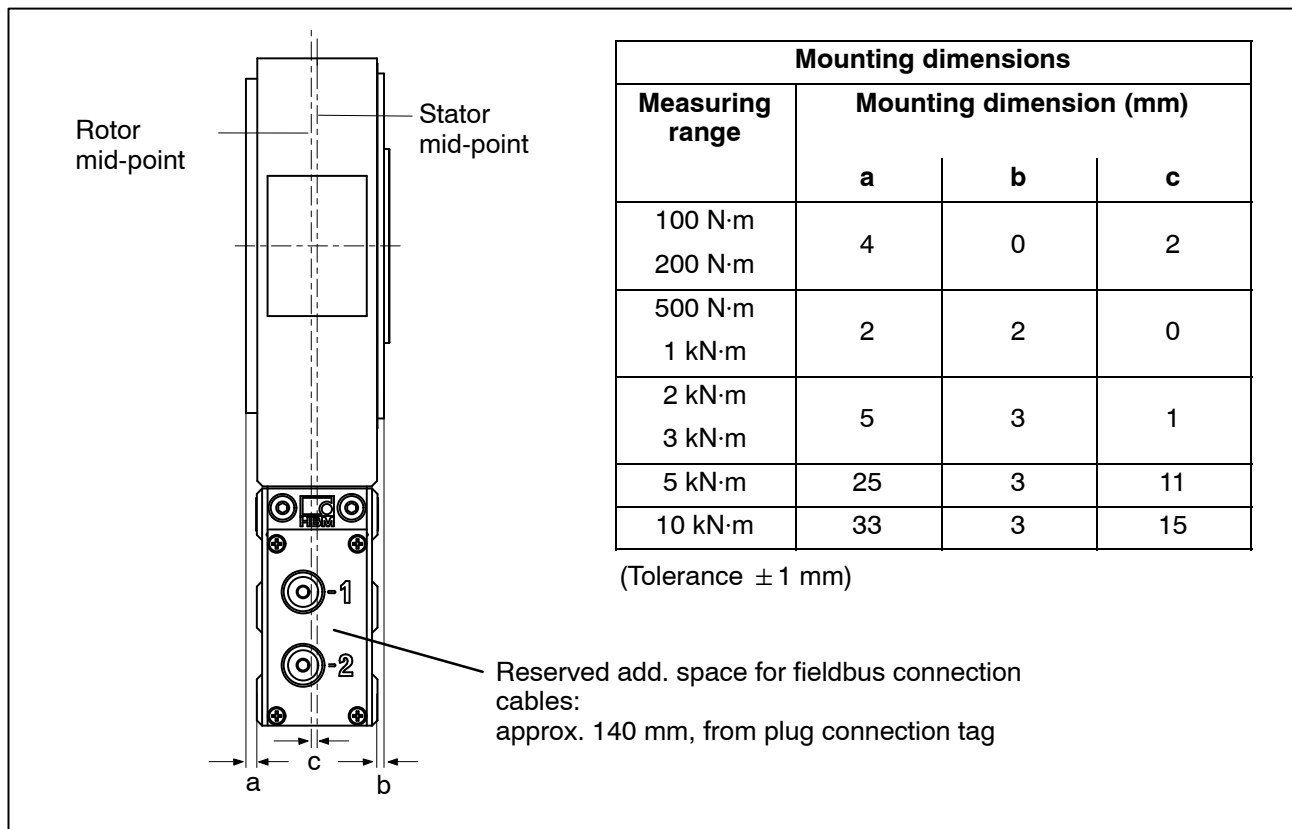

17 Supplementary technical information

Axial and radial run-out tolerances

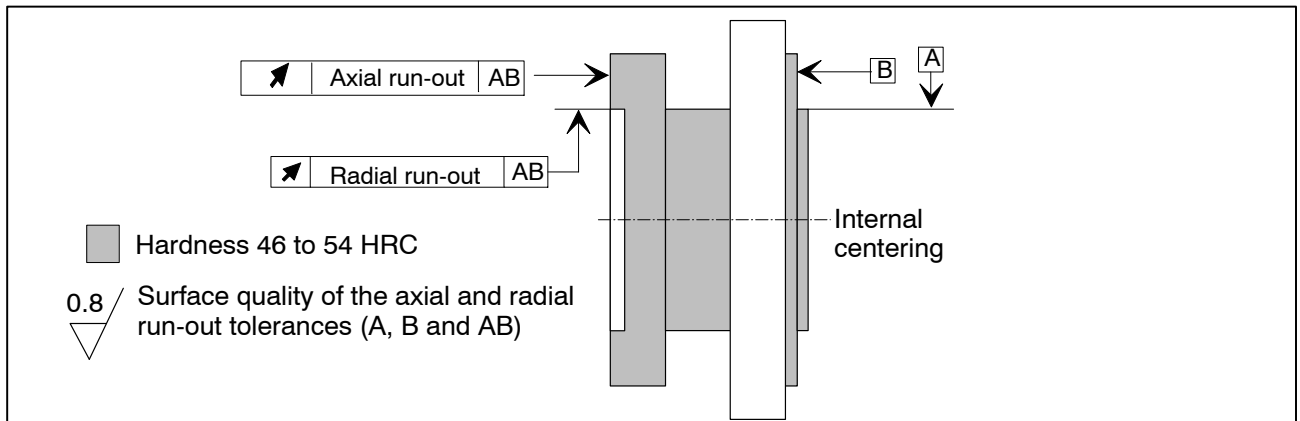

Measuring range (N·m)	Axial run-out tolerance (mm)	Radial run-out tolerance (mm)
100	0.01	0.01
200	0.01	0.01
500	0.01	0.01
1 k	0.01	0.01
2 k	0.02	0.02
3 k	0.02	0.02
5 k	0.025	0.025
10 k	0.025	0.025

18 Condition at the time of delivery

Parameter factory settings are marked with an asterisk (*). Underlined parameters are not overwritten by returning to the factory settings.

SYSTEM	
Default settings	
Project name	My Project
Language	Deutsch; English
Define pass code (1 – 9999)	0
Pass code active?	Yes*; No
Reactivate pass code	Reactivate pass code
LED display mode	Standard (measuring mode) Rotor clearance setting mode Opt. rotational speed measuring system setting mode
Fieldbus interfaces	
CANopen	
CAN address	110
CAN baud rate	100 kB; 125 kB; 250 kB; 500 kB; 1000 kB*
LSS manufacturer number	285
LSS product number	1025
LSS revision number	4294967040
LSS serial number	4294967040
PDO measuring rate divider	1; 2*; 4; 8; 16; 32; 64
Signal PDO 1 (transmit, max. 4.8 kHz)	Off Torque low pass 1* Torque + rotational speed low pass 1 Torque low pass 1 + angle of rotation
Signal PDO 2 (transmit, max. 1.2 kHz)	Off Torque low pass 2* Torque + rotational speed low pass 2
Signal PDO 3 (transmit, max. 0.6 kHz)	Off* Power + rotor temperature
Signal PDO 4 (transmit, max. 0.6 kHz)	Off* Status for torque, rotational speed/angle of rotation
Write calibration information	
Torque calibration date (dd.mm.yyyy)	30.11.06
Torque calibration initials	RH
Torque calibration cycle	0
Measuring point number	0
Calibration date for rotational speed/angle of rotation output (dd.mm.yyyy)	30.11.06

Calibration initials for rotational speed/angle of rotation output	KM
Calibration cycle for rotational speed/angle of rotation output	0
Measuring point number	0
Voltage calibration date (dd.mm.yyyy)	30.11.06
Voltage calibration initials	HM
Voltage calibration cycle	0
Measuring point number	0
Pass code input	
Enter pass code (1 – 9999)	0
TRANSDUCER PARAMETERIZATION	
Torque	
Measuring point designation	MyTorqueMeasPnt
Measuring point number	0
Unit	Nm*; kNm; ozfin; ozfft; lbfm; lbfft
Decimal point	.; .0; .00; .000*; .0000; .00000
Sign	Positive*; negative
Low pass filter 1 (nominal (rated) value)	0.05 Hz; 0.1 Hz; 0.2 Hz; 0.5 Hz; 1 Hz; 2 Hz; 5 Hz; 10 Hz; 20 Hz; 50 Hz; 100 Hz; 200 Hz; 500 Hz; 1 kHz*; 2 kHz; 4 kHz
Low pass filter 2 (nominal (rated) value)	0.05 Hz; 0.1 Hz; 0.2 Hz; 0.5 Hz; 1 Hz*; 2 Hz; 5 Hz; 10 Hz; 20 Hz; 50 Hz; 100 Hz
Measure point 1	Measure point 1
Actual value of physical point 1	0.000*
Setpoint (value) of physical point 1	0.000*
Measure point 2	Measure point 2
Actual value of physical point 2	100.000*
Setpoint (value) of physical point 2	100.000*
2-point scaling	Active; deactivated*
Rotational speed	
Unit	1/min*; rpm; 1/s; rad/s
Decimal point	.; .0; .00; .000*
Sign	Positive*; negative
Low-pass filter 1 (nominal (rated) value)	0.05 Hz; 0.1 Hz; 0.2 Hz; 0.5 Hz; 1 Hz; 2 Hz; 5 Hz; 10 Hz; 20 Hz; 50 Hz; 100 Hz; 200 Hz; 500 Hz; 1 kHz*; 2 kHz; 4 kHz
Low-pass filter 2 (nominal (rated) value)	0.05 Hz; 0.1 Hz; 0.2 Hz; 0.5 Hz; 1 Hz*; 2 Hz; 5 Hz; 10 Hz; 20 Hz; 50 Hz; 100 Hz
Angle of rotation	
Unit	Degree*; rad
Decimal point	.; .0*; .00
Signal for zero balance	Rotational speed sensor* (with reference signal); Command* (without reference signal)

Rotational speed/angle of rotation output	
Measuring point designation	MySpeedMeasPnt
Measuring point number	0
Mechanical increments	360*/720*
Signals F1/ F2	Frequency* Pulse (pos. edge)/direction of rotation Pulse (pos./neg. edge)/direction of rotation Pulse (4 edges)/direction of rotation
Output pulse division	1*; 2; 4; 6; 8; 12
Increments per revolution	360*/720*
Hysteresis for reversing the direction of rotation	On*; Off
Frequency output	
Signal	Torque low pass 1* Torque low pass 2
Mode	10 +/- 5 kHz* 60 +/- 30 kHz*
Setpoint (value) of physical point 1	0.000* (dep. on nominal (rated) measuring range)
Setpoint (value) of physical point 2	1000.000* (dep. on nominal (rated) measuring range)
Frequency of point 1	10.000000* (dep. on electrical configuration)
Frequency of point 2	15.000000* (dep. on electrical configuration)
Analog output	
Signal	Torque low pass 1* Torque low pass 2 Rotational speed low pass 1 Rotational speed low pass 2
Measuring point number	0
Mode	10 V*
Setpoint (value) of physical point 1	0.000*
Setpoint (value) of physical point 2	1000.000*
Voltage of point 1	0.0000*
Voltage of point 2	10.0000*
Power	
Unit	W; kW*; MW; hp
Decimal point	.; .0; .00; .000*
Low pass filter (-1 dB)	0.1 Hz; 1 Hz*; 10 Hz; 100 Hz
SIGNAL CONDITIONING	
Torque	
Shunt	On; Off*
Shunt signal (of nominal (rated) value)	10%; 50%*
Zero signal compensation	Zero signal compensation
Zero value	0.000*

Angle of rotation		
Measuring range	0 to n x 360 degrees, pos. direction of rotation* 0 to n x 360 degrees, neg. direction of rotation 0 to -n x 360 degrees, pos. direction of rotation 0 to -n x 360 degrees, neg. direction of rotation -n x 360 to n x 360 degrees, pos. direction of rotation -n x 360 to n x 360 degrees, neg. direction of rotation	
Number of revolutions n	1*; 2; 3; 4	
ADDITIONAL FUNCTIONS		
Limit values		
Limit value 1		
Monitoring	On; Off*	On; Off*
Signal	Torque low pass 1* Torque low pass 2	Rotational speed low pass 1* Rotational speed low pass 2
Switching direction	Overshoot* Undershoot	Overshoot* Undershoot
Level	10.000*	10.0*
Hysteresis	0.500*	0.5*
Limit value 2		
Monitoring	On; Off*	On; Off*
Signal	Torque low pass 1* Torque low pass 2	Rotational speed low pass 1* Rotational speed low pass 2
Switching direction	Overshoot* Undershoot	Overshoot* Undershoot
Level	10.000*	10.0*
Hysteresis	0.500*	0.5*
Limit value 3		
Monitoring	On; Off*	On; Off*
Signal	Torque low pass 1* Torque low pass 2	Rotational speed low pass 1* Rotational speed low pass 2
Switching direction	Overshoot Undershoot*	Overshoot Undershoot*
Level	-10.000*	-10.0*
Hysteresis	0.500*	0.5*
Limit value 4		
Monitoring	On; Off*	On; Off*
Signal	Torque low pass 1* Torque low pass 2	Rotational speed low pass 1* Rotational speed low pass 2

Switching direction	Overshoot Undershoot*	Overshoot Undershoot*
Level	-10.000*	-10.0*
Hysteresis	0.500*	0.5*
SAVE/LOAD PARAMETERS		
Load from transducer		
Choose parameter set	1*; 2; 3; 4; factory settings	
Save to transducer		
Choose parameter set	1; 2; 3; 4	
TEDS template for torque	HBM Frequency Sensor* High Level Voltage Output	
Rotational speed/angle of rotation output	HBM Frequency Sensor* HBM Pulse Sensor	

19 Ordering numbers

Code	Option 1: measuring range
S100Q	100 N·m
S200Q	200 N·m
S500Q	500 N·m
S001R	1 kN·m
S002R	2 kN·m
S003R	3 kN·m
S005R	5 kN·m
S010R	10 kN·m

Code	Option 2: accuracy
S	Standard
G	Greater accuracy ¹⁾ Lin. < ±0.01% and TK ₀ < ±0.01%/10 K

Code	Option 3: nominal (rated) rotational speed
L	Dependent on meas. range up to 15 000 rpm
H	Dependent on meas.range up to 18 000 rpm

Code	Option 4: electrical configuration
DF1	Output signal 60 kHz ± 30 kHz
DU2	Output signal 60 kHz ± 30 kHz and ± 10 V
SF1	Output signal 10 kHz ± 5 kHz
SU2	Output signal 10 kHz ± 5 kHz and ± 10 V

Code	Option 5: bus connection
C	CANopen (2 device plugs)
P	CANopen and Profibus DPV1

Code	Option 6: rotational speed measuring system
N	Without rotational speed measuring system
1	With optical rotational speed measuring system; 360 or 720 pulses/revolution
A	With optical rotational speed measuring system; 360 or 720 pulses/revolution and reference signal

Code	Option 7: protection against contact
N	Without protection against contact
Y	With protection against contact

Code	Option 8: MODULFLEX [®] coupling ²⁾
N	Without coupling
Y	With fitted coupling

Code	Option 9: Customized modification
N	No customized modification

Order no.:

K-T12 - [] [] [] [] - [] - [] - [] [] [] [] - [] - [] - [] - [] - []

Ordering example:

K-T12 - [S] [5] [0] [0] [Q] - [S] - [L] - [S] [F] [1] - [C] - [1] - [N] - [N] - [N]

1) For voltage output: lin. < ±0.05% ; TK₀ < ±0.1%/10 K
 2) For Option 3, code L only; see data sheet B1957-xx de for specifications.

20 Accessories

Article	Order no.
Connection cable, set	
Torque	
Torque connection cable, Binder 423 7pin-D-Sub 15-pin, 6 m	1-KAB149-6
Torque connection cable, Binder 423 free ends, 6 m	1-KAB153-6
Rotational speed	
Torque connection cable, Binder 423 8-pin-D-Sub 15-pin, 6 m	1-KAB150-6
Rotational speed connection cable, Binder 423 8-pin free ends, 6 m	1-KAB154-6
Rotational speed connection cable, reference signal, Binder 423 8-pin-D-Sub 15-pin, 6 m	1-KAB163-6
Rotational speed connection cable, reference signal, Binder 423 8-pin free ends, 6 m	1-KAB164-6
CAN Bus	
CAN Bus M12 connection cable, A-coded, D-Sub 9-pin, switchable termination resistor, 6 m	1-KAB161-6
Plugs/sockets	
Torque	
423G-7S, 7-pin cable socket, straight cable entry, for torque output (plug 1, plug 3)	3-3101.0247
423W-7S, 7-pin cable socket, 90° cable entry, for torque output (plug 1, plug 3)	3-3312.0281
Rotational speed	
423G-8S, 8-pin cable socket, straight cable entry, for rotational speed output (plug 2)	3-3312.0120
423W-8S, 8-pin cable socket, 90° cable entry, for rotational speed output (plug 2)	3-3312.0282
CAN Bus	
TERMINATOR M12/termination resistor, M12, A-coded, 5-pin, plug	1-CANHEAD-TERM
Termination resistor, CAN Bus M12, A-coded, 5-pin, socket	1-CAN-AB-M12
T-SPLITTER M12/T-piece M12, A-coded, 5-pin	1-CANHEAD-M12-T
Cable plug/socket/CAN Bus M12, cable socket 5-pin M12, A-coded, cable plug 5-pin M12, A-coded	1-CANHEAD-M12
PROFIBUS	
Connection cable, Y-splitter, M12 socket, B-coded; M12 plug, B-coded; M12 socket, B-coded, 2 m	1-KAB167-2
Cable plug/socket/PROFIBUS M12, cable socket 5-pin M12, B-coded, cable plug 5-pin M12, B-coded	1-PROFI-M12
Termination resistor PROFIBUS M12, B-coded, 5-pin	1-PROFI-AB-M12
T-piece PROFIBUS M12, B-coded, 5-pin	1-PROFI-VT-M12
Connection cable, by the meter	
Kab8/00-2/2/2	4-3301.0071
Kab8/00-2/2/2/1/1	4-3301.0183
DeviceNet cable	4-3301.0180
Other	
Setup toolkit for T12 (System CD T12, PCAN-USB adapter, CAN Bus connection cable, 6 m)	1-T12-SETUP-USB

© Hottinger Baldwin Messtechnik GmbH.

Subject to modifications.

All details describe our products in general form only.

They are not to be understood as a guarantee of quality or durability.

Hottinger Baldwin Messtechnik GmbH

Im Tiefen See 45 • 64293 Darmstadt • Germany

Tel. +49 6151 803-0 • Fax: +49 6151 803-9100

Email: info@hbm.com • www.hbm.com

measure and predict with confidence

