

HP 1920 Gigabit Ethernet Switch Series

Getting Started Guide



5998-5626

Part number: 5998-5626

Document version: 6W101-20140820



Legal and notice information

© Copyright 2014 Hewlett-Packard Development Company, L.P.

No part of this documentation may be reproduced or transmitted in any form or by any means without prior written consent of Hewlett-Packard Development Company, L.P.

The information contained herein is subject to change without notice.

HEWLETT-PACKARD COMPANY MAKES NO WARRANTY OF ANY KIND WITH REGARD TO THIS MATERIAL, INCLUDING, BUT NOT LIMITED TO, THE IMPLIED WARRANTIES OF MERCHANTABILITY AND FITNESS FOR A PARTICULAR PURPOSE. Hewlett-Packard shall not be liable for errors contained herein or for incidental or consequential damages in connection with the furnishing, performance, or use of this material.

The only warranties for HP products and services are set forth in the express warranty statements accompanying such products and services. Nothing herein should be construed as constituting an additional warranty. HP shall not be liable for technical or editorial errors or omissions contained herein.

Contents

Preparing for installation	1
Safety recommendations	1
Examining the installation site	2
Temperature/humidity	2
Cleanness	2
EMI	3
Installing the switch	4
Mounting the switch in a 19-inch rack by using mounting brackets	4
Mounting the switch on a workbench	7
Mounting the switch on a wall	7
Connecting cables	9
Connecting network cable	9
Installing the SFP transceiver module and optical fibers	9
Connecting the console cable	10
Connecting the AC power cord	10
Connecting the DC power cord	11
Verifying the installation	12
Accessing the switch for the first time	13
Setting up the configuration environment	13
Connecting the console cable	13
Console cable	13
Connection procedure	14
Setting terminal parameters	14
Powering on the switch	17
Verification before power-on	17
Powering on the switch	17
Support and other resources	19
Contacting HP	19
Subscription service	19
Related information	19
Documents	19
Websites	19
Conventions	20
Appendix A Chassis views and technical specifications	22
Chassis views	22
1920-8G	22
1920-16G	22
1920-24G	23
1920-48G	23
1920-8G-PoE+ (65W)	24
1920-8G-PoE+ (180W)	24
1920-24G-PoE+ (180W)	25
1920-24G-PoE+ (370W)	25
Physical specifications	26
Chassis dimensions and weights	26
Ports and interface card slots	26
Environmental specifications	27

Power specifications	27
AC input voltage specifications	27
RPS DC input voltage specifications and RPS compatibility	27
Power consumption specifications for non-PoE switches	27
Power consumption specifications for PoE switches	27
Cooling system	28
Appendix B LEDs.....	29
Power LED	29
Copper port LEDs	29
Fiber port LEDs.....	29
RPS LED.....	30
Appendix C Troubleshooting	31

Preparing for installation

The HP 1920 Gigabit Ethernet Switch Series includes models listed in [Table 1](#).

Table 1 HP 1920 Gigabit Ethernet Switch Series models

Product code	HP description	Alias	RMN
Non-PoE			
JG920A	HP 1920-8G Switch	1920-8G	HNGZA-HA0008
JG923A	HP 1920-16G Switch	1920-16G	HNGZA-HA0011
JG924A	HP 1920-24G Switch	1920-24G	HNGZA-HA0012
JG927A	HP 1920-48G Switch	1920-48G	HNGZA-HA0015
PoE			
JG921A	HP 1920-8G-PoE+ (65W) Switch	1920-8G-PoE+ (65W)	HNGZA-HA0009
JG922A	HP 1920-8G-PoE+ (180W) Switch	1920-8G-PoE+ (180W)	HNGZA-HA0010
JG925A	HP 1920-24G-PoE+ (180W) Switch	1920-24G-PoE (180W)	HNGZA-HA0013
JG926A	HP 1920-24G-PoE+ (370W) Switch	1920-24G-PoE (370W)	HNGZA-HA0014

! **IMPORTANT:**

For regulatory identification purposes, the switches are assigned Regulatory Model Numbers (RMNs). The RMNs should not be confused with the marketing name HP 1920, or the product codes.

Safety recommendations

To avoid any equipment damage or bodily injury, read the following safety recommendations before installation. The recommendations do not cover every possible hazardous condition.

- To avoid damage to the electrolytic capacitor in the switch, do not store the switch without power for more than one year.
- Before cleaning the switch, remove all power cords from the switch. Do not clean the switch with a wet cloth or liquid.
- Do not place the switch near water or in a damp environment. Prevent water or moisture from entering the switch chassis.
- Do not place the switch on an unstable case or desk. The switch might be severely damaged in case of a fall.
- Ensure good ventilation of the equipment room and keep the air inlet and outlet vents of the switch free of obstruction.
- Make sure the operating voltage is in the required range.
- To avoid electrical shocks, do not open the chassis while the switch is operating or when the switch is just powered off.

- The accessories shipped with the switch, including but not limited to power cables, are intended only for the switch. Please do not use them for other products.

Examining the installation site

The switches must be used indoors. You can mount your switch in a rack or on a workbench, but make sure:

- A minimum clearance of 5 cm (1.97 in) is reserved at the air inlet and exhaust vents for ventilation.
- The rack or workbench has a good ventilation system.
- The rack or workbench is sturdy enough to support the switch and its accessories.
- The rack or workbench is reliably grounded.

To ensure correct operation and long service life of your switch, install it in an environment that meets the requirements described in the following subsections.

Temperature/humidity

Maintain temperature and humidity in the equipment room as described in "[Environmental specifications](#)."

- Lasting high relative humidity can cause poor insulation, electricity creepage, mechanical property change of materials, and metal corrosion.
- Lasting low relative humidity can cause washer contraction and ESD and bring problems including loose captive screws and circuit failure.
- High temperature can accelerate the aging of insulation materials and significantly lower the reliability and lifespan of the switch.

Cleaness

Dust buildup on the chassis might result in electrostatic adsorption, which causes poor contact of metal components and contact points, especially when indoor relative humidity is low. In the worst case, electrostatic adsorption can cause communication failure.

Table 2 Dust concentration limit in the equipment room

Substance	Concentration limit (particles/m ³)
Dust	≤ 3 × 10 ⁴ (no visible dust on the tabletop over three days)

NOTE:

Dust diameter ≥ 5 μm

The equipment room must also meet strict limits on salts, acids, and sulfides to eliminate corrosion and premature aging of components, as shown in [Table 3](#).

Table 3 Harmful gas limits in the equipment room

Gas	Maximum concentration (mg/m ³)
SO ₂	0.2
H ₂ S	0.006

Gas	Maximum concentration (mg/m³)
NH ₃	0.05
Cl ₂	0.01

EMI

All electromagnetic interference (EMI) sources, from outside or inside of the switch and application system, adversely affect the switch in the following ways:

- A conduction pattern of capacitance coupling.
- Inductance coupling.
- Electromagnetic wave radiation.
- Common impedance (including the grounding system) coupling.

To prevent EMI, use the following guidelines:

- If AC power is used, use a single-phase three-wire power receptacle with protection earth (PE) to filter interference from the power grid.
- Keep the switch far away from radio transmitting stations, radar stations, and high-frequency devices.
- Use electromagnetic shielding when necessary. For example, use shielded interface cables.

Installing the switch

⚠ WARNING!

Before installing or moving the switch, remove the power cord.

You can install an HP 1920 switch in a 19-inch rack, on a workbench, or on a wall.

Mounting the switch in a 19-inch rack by using mounting brackets

1. Wear an ESD wrist strap and make sure it makes good skin contact and is reliably grounded.
2. Verify that the rack is securely grounded and is stable.
3. Select mounting brackets for the switch.
 - The HP 1920-8G switch uses Type-A mounting brackets, as shown in [Figure 1](#).
 - The HP 1920-8G-PoE+ (65W) and 1920-8G-PoE+ (180W) switches use Type-B mounting brackets, as shown in [Figure 2](#).
 - The HP 1920-16G, 1920-24G, 1920-24G-PoE+ (180W), 1920-24G-PoE+ (370W) and 1920-48G switches use Type-C mounting brackets, as shown in [Figure 3](#).
4. Attach the mounting brackets to both sides of the chassis with screws.

NOTE:

Mounting brackets are used only for securing the switch to the rack. A rack shelf on the rack is used to bear the switch weight.

Figure 1 Attaching Type-A mounting brackets to the switch

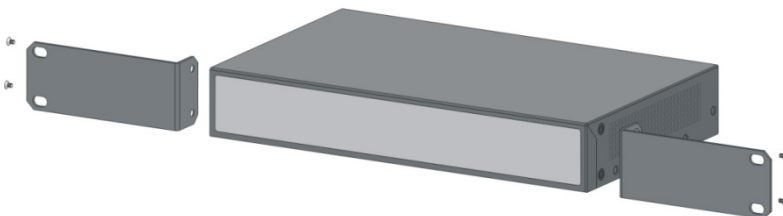

Figure 2 Attaching Type-B mounting brackets to the switch

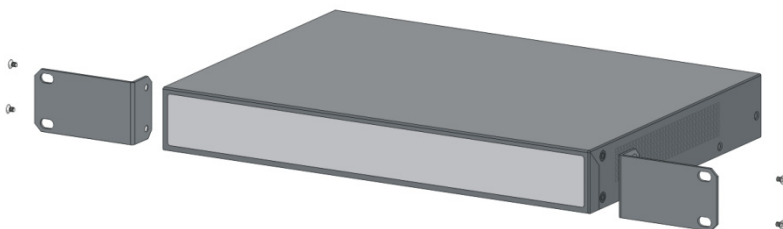
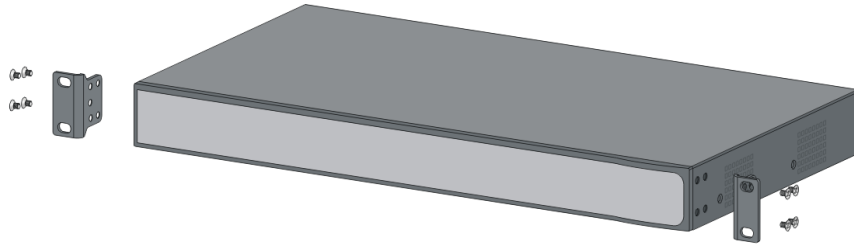

Figure 3 Attaching Type-C mounting brackets to the switch



5. Place the switch on a rack shelf in the rack. Push the switch in until the oval holes in the brackets align with the mounting holes in the rack posts.
6. Attach the mounting brackets to the rack posts with screws.

Figure 4 Attaching Type-A mounting brackets to the rack post

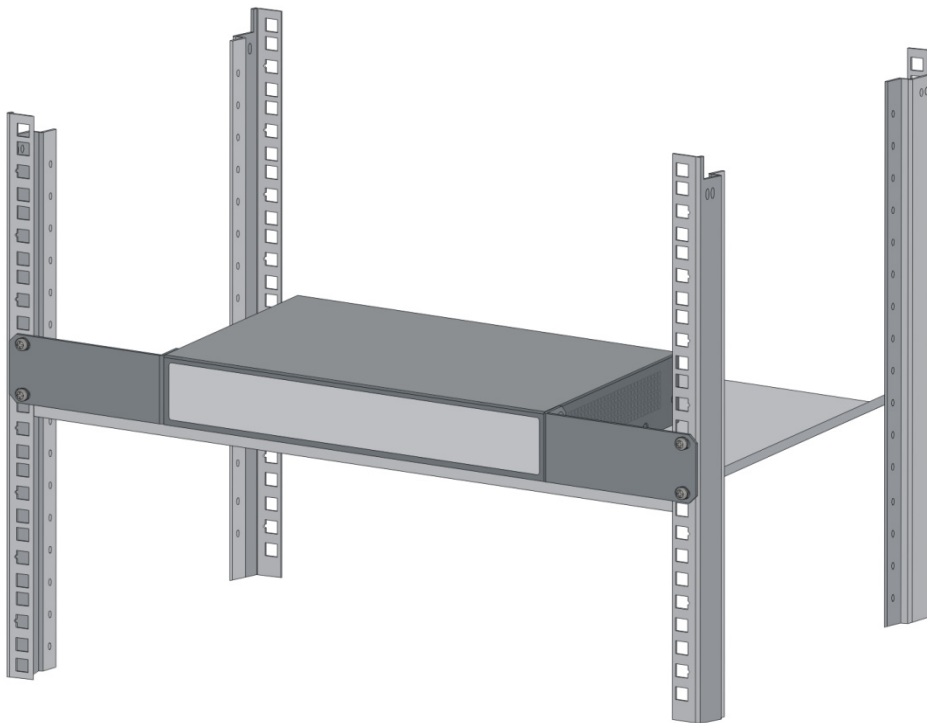

Figure 5 Attaching Type-B mounting brackets to the rack post

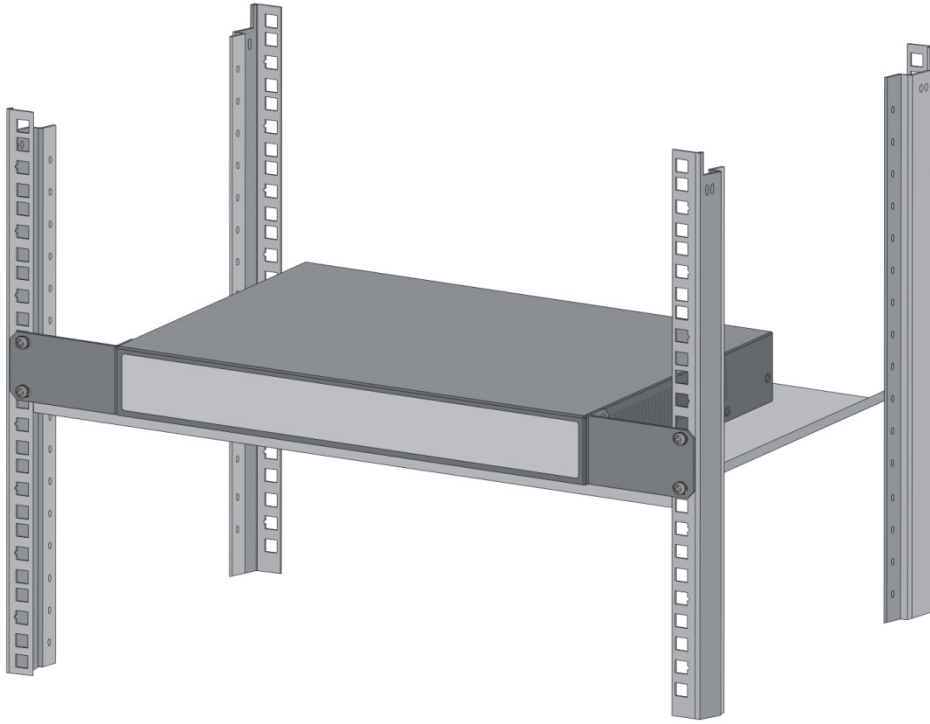
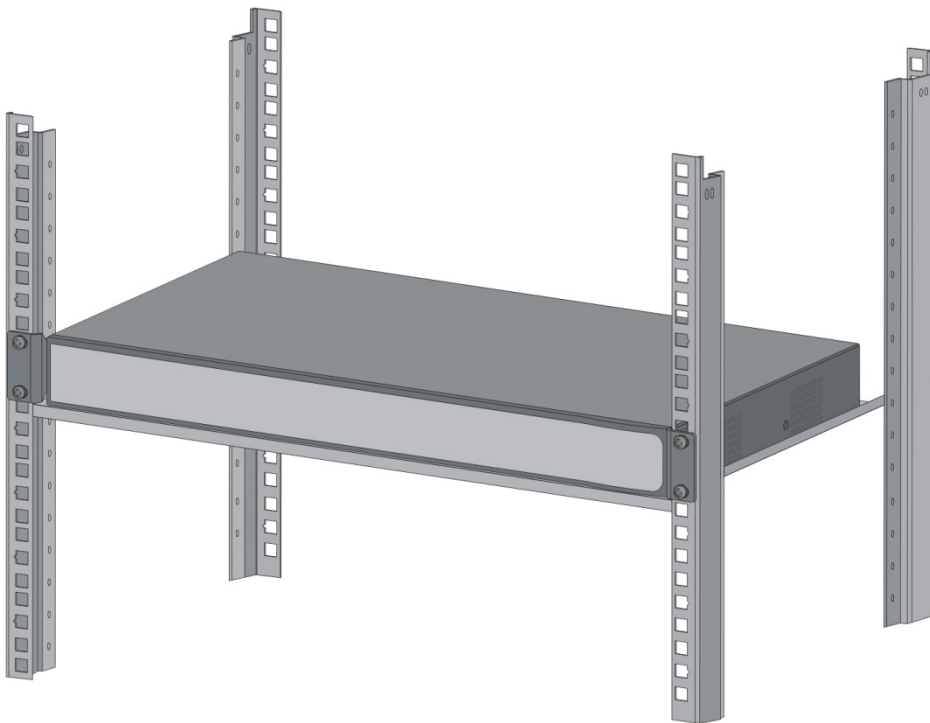

Figure 6 Attaching Type-C mounting brackets to the rack post



Mounting the switch on a workbench

! IMPORTANT:

- Reserve a clearance of 10 cm (3.9 in) around the chassis for heat dissipation.
- Do not place heavy objects on the switch.

To mount the switch on a workbench:

1. Verify that the workbench is sturdy and reliably grounded.
2. Place the switch bottom up, and clean the round holes in the chassis bottom with a dry cloth.
3. Attach the rubber feet to the four round holes in the chassis bottom.
4. Place the switch upside up on the workbench.

Figure 7 Attaching rubber feet (HP 1920-24G-PoE+ Switch)

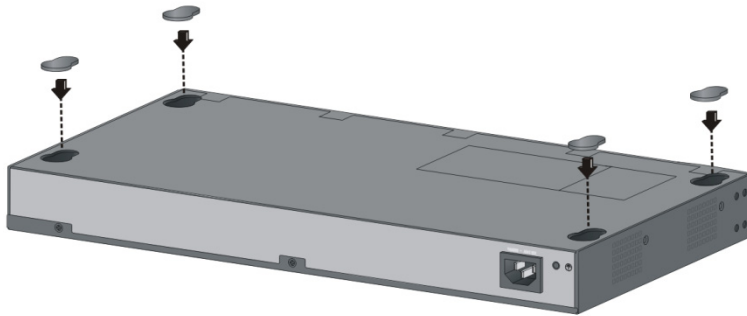

Mounting the switch on a wall

Only the HP 1920-8G switch can be installed on a wall. The type of screws used to mount the switch on the wall depends on the wall type. This section uses a concrete wall as an example.

Wall-mounting anchor kits are user supplied. The screws must be a minimum of 3 mm (0.12 in) in diameter, and the screw head must be a minimum of 6 mm (0.24 in) in diameter.

Figure 8 Wall-mounting anchor kit

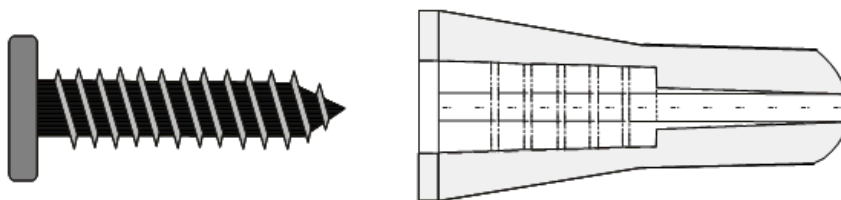

To install the switch on a concrete wall:

1. Drill two holes at the same height. Make sure the spacing in between is 160 mm (6.30 in), as shown in [Figure 9](#).

The hole depth and diameter depend on the wall anchors and screws you use. Make sure you can push the anchors to their full depth in the holes.

Figure 9 Hole spacing

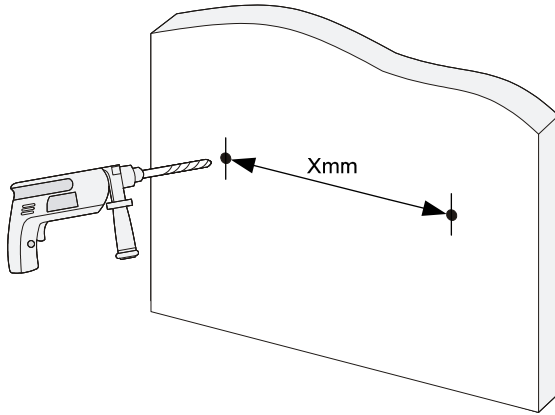

2. Insert one wall anchor into each hole until the anchors are flush with the wall surface.
3. Drive one screw into each wall anchor, and tighten the screws just enough to keep it secure in the wall anchor.

Leave a minimum clearance of 1.5 mm (0.06 in) between the base of the screw head and the wall anchor so the switch can hang on the screws securely.

Figure 10 Driving a screw into a wall anchor

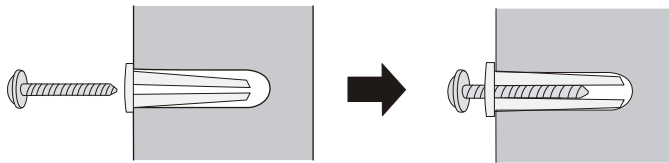

4. Align the two mounting holes in the switch chassis bottom with the two screws on the wall and hang the switch.
Make sure the Ethernet ports are facing downwards and the chassis side panels are perpendicular to the ground.

Figure 11 Wall mounting

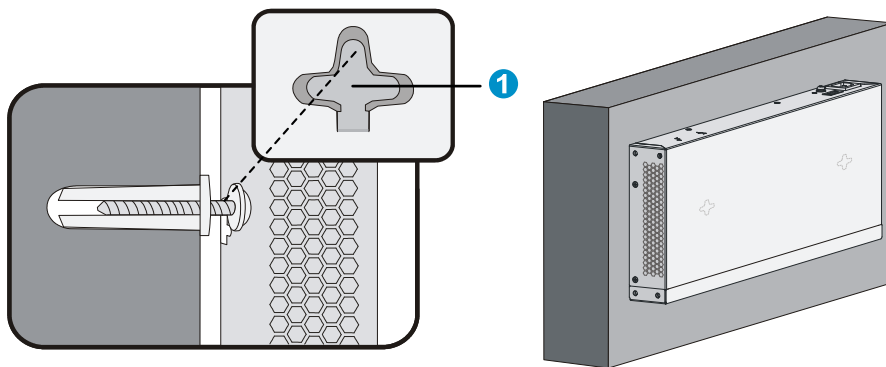

(1) Mounting hole in the switch chassis bottom

Connecting cables

Connecting network cable

Use crossover cable or straight through cable to connect a PC or other network devices to the Ethernet port of the switch.

Figure 12 Connecting network cable

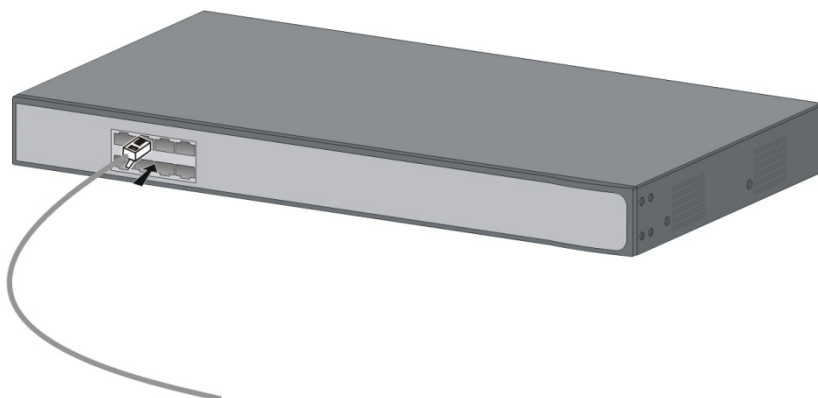

Installing the SFP transceiver module and optical fibers

△ CAUTION:

- Hold the SFP transceiver module by its two sides when you install or remove the module. Do not touch the golden finger of the module.
 - Remove the optical fiber, if any, from a transceiver module before installing it.
-

To install an SFP transceiver module and optical fibers:

1. Wear an ESD wrist strap and make sure it makes good skin contact and is reliably grounded.
 2. Pivot the clasp of the module up. Holding the module, gently push the module into the slot until it has firm contact with the slot (when the top and bottom spring tabs catch in the slot).
 3. Remove protective sleeves from optical fibers, and the dust plug from the transceiver module.
 4. Connect the LC connectors of the optical fibers to the transceiver module.
-

NOTE:

Keep the protective sleeves for future use.

Figure 13 Installing the SFP transceiver module and optical fibers

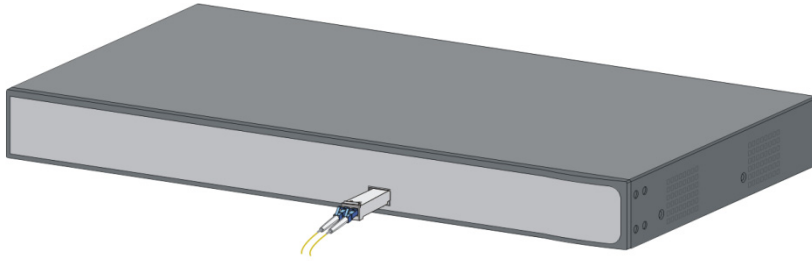

Connecting the console cable

To connect a terminal (for example, a PC) to the switch:

1. Wear an ESD wrist strap and make sure it makes good skin contact and is reliably grounded.
2. Connect the DB-9 female connector of the console cable to the serial port of the PC.
3. Connect the RJ-45 connector to the console port of the switch.

Figure 14 Connecting the console cable

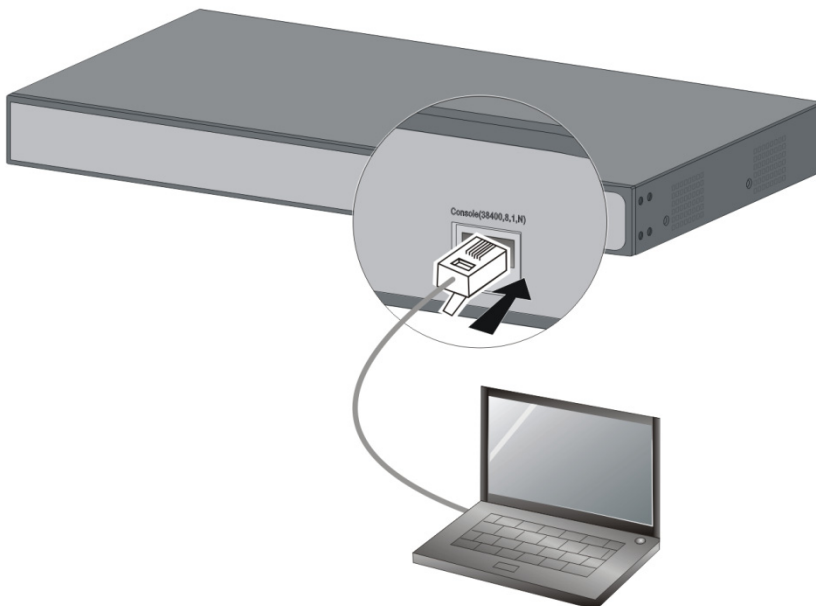

NOTE:

To disconnect the console cable, remove the RJ-45 connector of the cable and then the DB-9 female connector.

Connecting the AC power cord

1. Wear an ESD wrist strap and make sure it makes good skin contact and is reliably grounded.
2. Connect one end of the grounding cable to the grounding screw on the rear panel, and connect the other end to the ground.
3. Make sure the correct power source is used.

4. Connect one end of the AC power cord to the AC power receptacle on the switch.
5. Connect the other end of the AC power cord to the AC power outlet.
6. Examine the power LED. If it is ON, the power connection is correct.

Figure 15 Connecting the AC power cord to the AC power receptacle

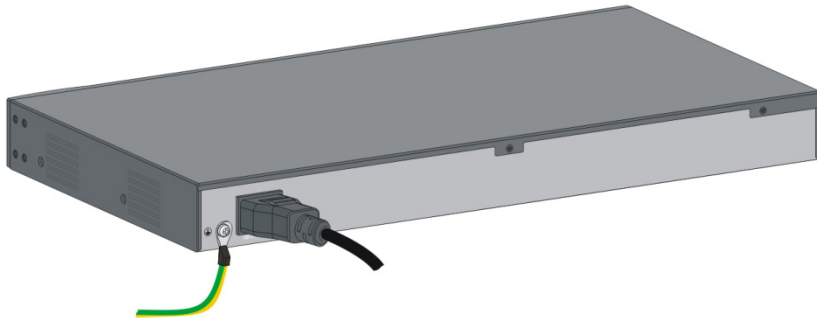

Connecting the DC power cord

! IMPORTANT:

Make sure the DC power cord is shorter than 3 m (9.84 ft).

Only the HP 1920-24G-PoE+ (370W) supports DC RPS power.

If only the DC power cord is connected, the switch operates correctly when the DC input voltage is in the range of -47 VDC to -57 VDC. If both AC and DC power cords are connected, the switch chooses the power supply based on the DC input voltage, as shown in [Table 4](#).

Table 4 Power supply selection criteria

DC input voltage	Power supply
-54 VDC to -57 VDC	DC
< -54 VDC	AC

To connect the DC power cord:

1. Wear an ESD wrist strap and make sure it makes good skin contact and is reliably grounded.
2. Connect one end of the grounding cable to the grounding screw on the rear panel, and connect the other end to the ground.
3. Insert the DC connector to the DC power receptacle.
If you cannot insert the connector into the receptacle, do not force it. Re-orient the connector and try to insert it again.
4. Use a flathead screwdriver to fasten screws on both sides of the connector.
5. Connect the other end of the DC power cord to the RPS. Make sure the RPS is supplying a minimum of 876 W power.
6. View the RPS LED to verify that the DC power cord is installed correctly.

Figure 16 Connecting the DC power cord to the DC power receptacle

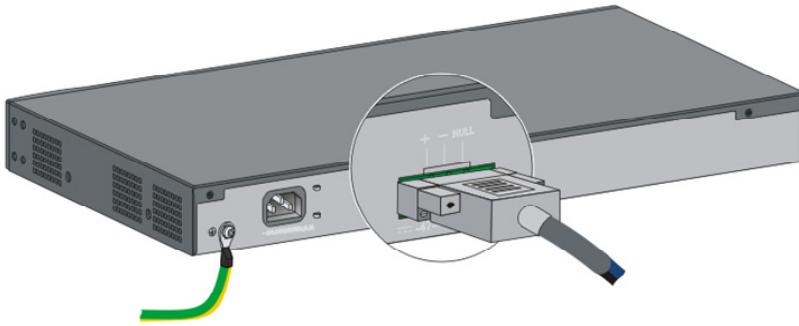

Verifying the installation

After you complete the installation, verify the following items:

- There is enough space for heat dissipation around the switch.
- The rack or workbench is stable.
- The grounding cable is securely connected.
- The correct power source is used.
- The power cords are correctly connected.
- All the interface cables are cabled indoors. If any cable is routed outdoors, verify that the socket strip with lightning protection and lightning arresters for network ports have been correctly connected.

Accessing the switch for the first time

Setting up the configuration environment

The first time you access the switch you must use a console cable to connect a console terminal, for example, a PC, to the console port on the switch.

Figure 17 Connecting the console port to a terminal

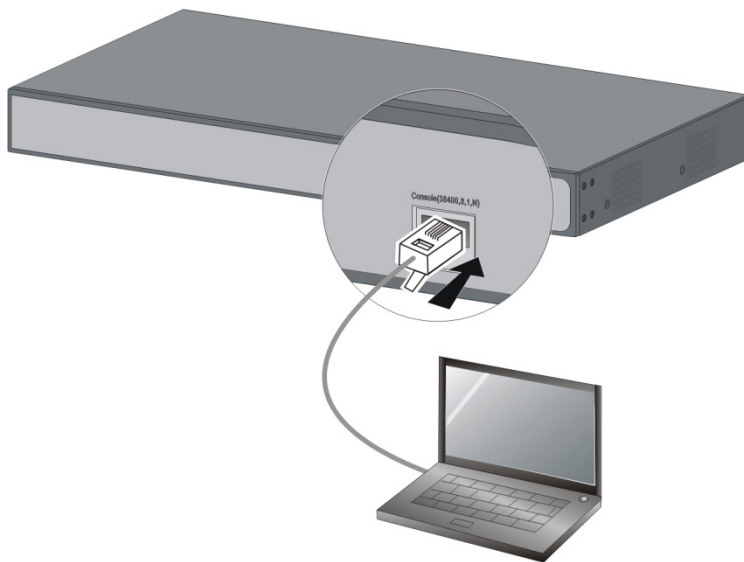

Connecting the console cable

Console cable

A console cable is an 8-core shielded cable. It has a crimped RJ-45 connector at one end for connecting to the console port of the switch, and a DB-9 female connector at the other end for connecting to the serial port on the console terminal.

Figure 18 Console cable

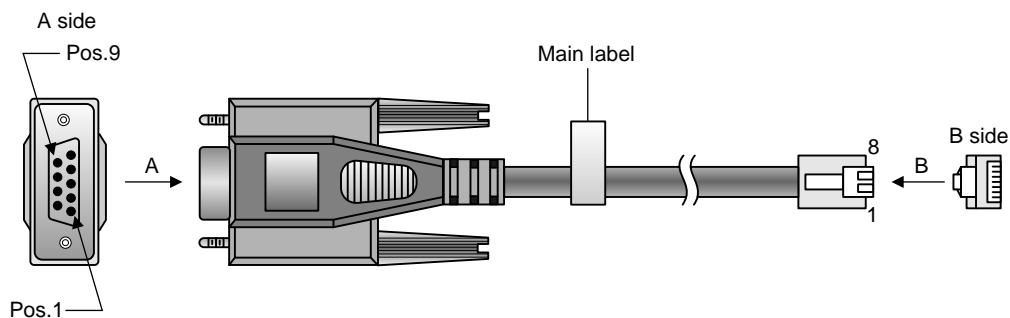

Connection procedure

⚠ CAUTION:

The serial ports on PCs do not support hot swapping. To connect a PC to an operating switch, first connect the PC end. To disconnect a PC from an operating switch, first disconnect the switch end.

To connect a terminal (for example, a PC) to the switch:

1. Wear an ESD wrist strap and make sure it makes good skin contact and is reliably grounded.
2. Connect the DB-9 female connector of the console cable to the serial port of the PC.
3. Connect the RJ-45 connector to the console port of the switch.

Identify the mark on the console port and make sure you are connecting to the correct port.

Setting terminal parameters

To configure and manage the switch, you must run a terminal emulator program on the console terminal.

The following terminal settings are required:

- **Bits per second**—38400.
- **Data bits**—8.
- **Parity**—None.
- **Stop bits**—1.
- **Flow control**—None.
- **Emulation**—VT100.

To set terminal parameters (for example, on a Windows XP HyperTerminal):

1. Select **Start > All Programs > Accessories > Communications > HyperTerminal**.
The **Connection Description** dialog box appears.
2. Enter the name of the new connection in the **Name** field and click **OK**.

Figure 19 Connection description

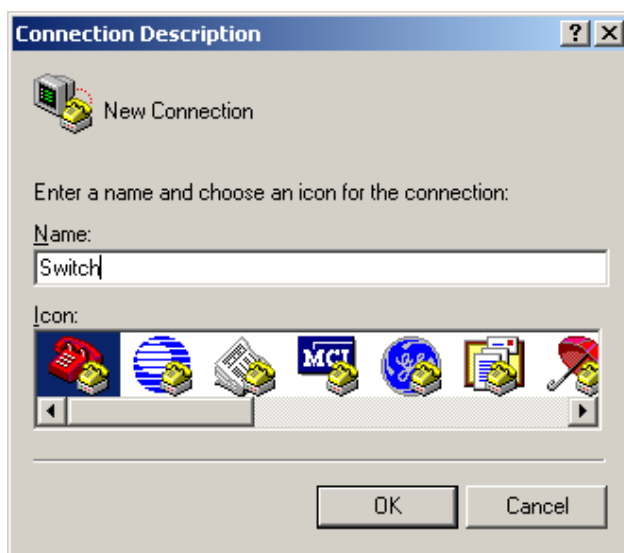

3. Select the serial port to be used from the **Connect using** list, and click **OK**.

Figure 20 Setting the serial port used by the HyperTerminal connection



4. Set **Bits per second** to **38400**, **Data bits** to **8**, **Parity** to **None**, **Stop bits** to **1**, and **Flow control** to **None**, and click **OK**.

Figure 21 Setting the serial port parameters

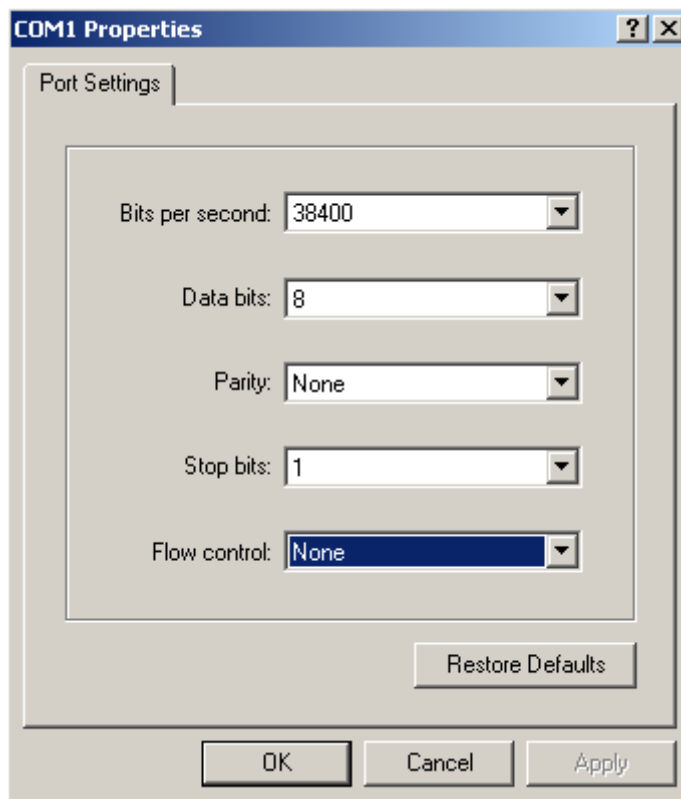

5. Select **File > Properties** in the HyperTerminal window.

Figure 22 HyperTerminal window

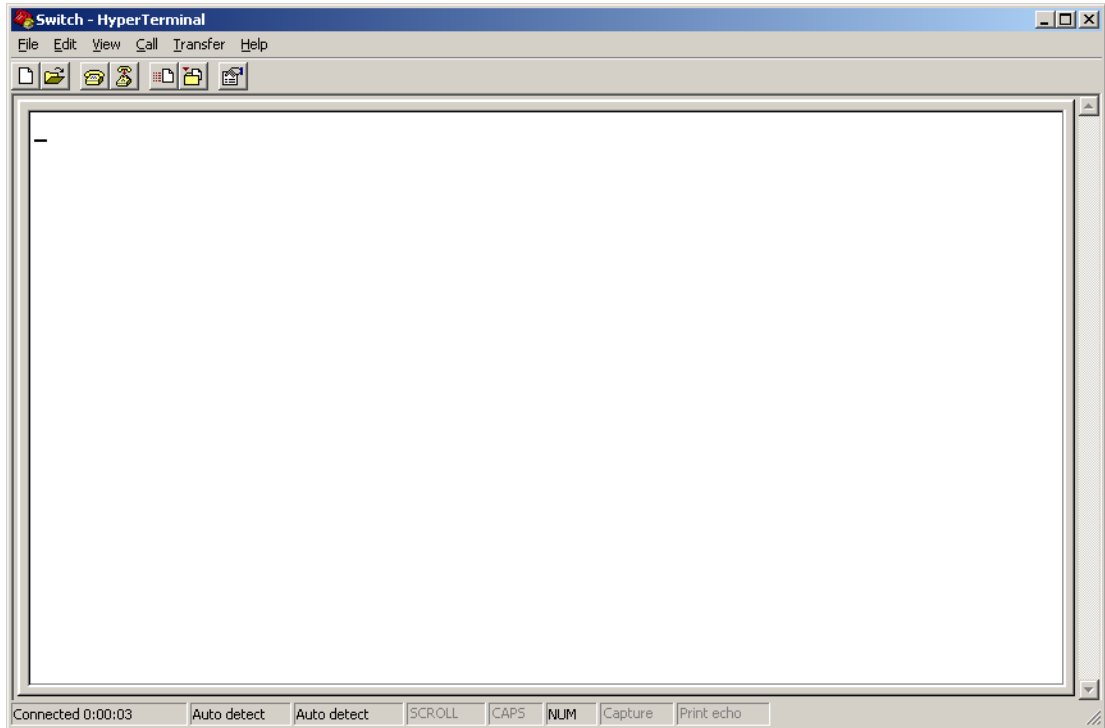

6. On the **Settings** tab, set the emulation to **VT100** and click **OK**.

Figure 23 Setting terminal emulation in Switch Properties dialog box

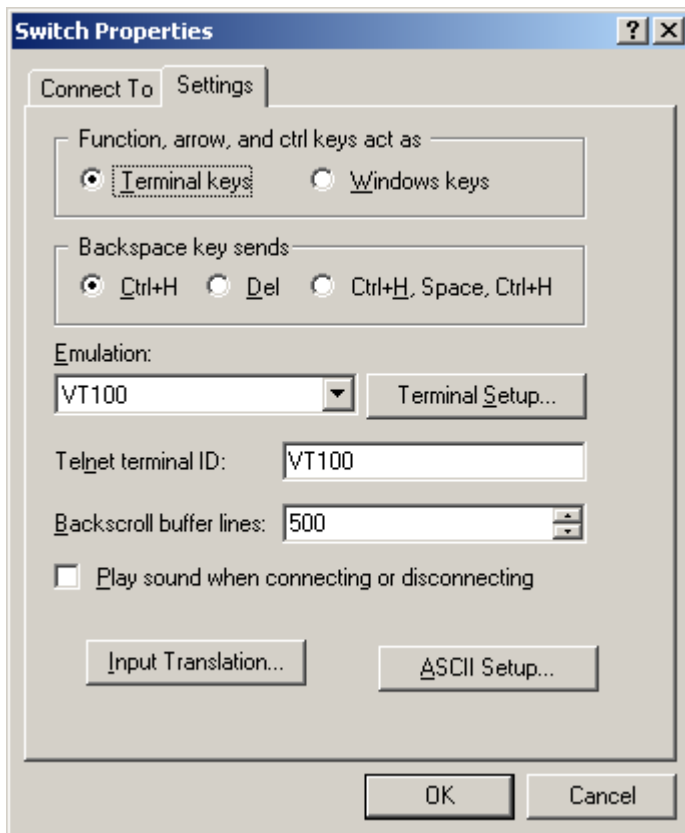

Powering on the switch

Verification before power-on

Before powering on the switch, verify the following items:

- The power cord is correctly connected.
- The input power voltage meets the requirement of the switch.
- The console cable is correctly connected.
- The terminal (for example, a PC) has started, and its configuration parameters have been correctly set.

Powering on the switch

Power on the switch (for example, an HP 1920-24G switch), and the following information is displayed:

Starting.....

```
*****
*
*          HP 1920-24G Switch JG924A BootWare, Version 1.09          *
*
*****
```

Copyright (c) 2010-2014 Hewlett-Packard Development Company, L.P.

```
Compiled Date       : Mar 20 2014 17:00:53
CPU Type            : MIPS4kec
CPU L1 Cache        : 16KB
CPU Clock Speed     : 500MHz
Memory Type         : DDR3 SDRAM
Memory Size         : 128MB
Memory Speed        : 300MHz
BootWare Size       : 3MB
Flash Size          : 32MB
```

BootWare Validating...

Press Ctrl+B to enter extended boot menu...

Starting to get the main application file--flash:/ 1920-24G.bin!.....

.....

```
The main application file is self-decompressing.....
.....
.....
.....
.....
.....
.....
.....
.....
.....
.....
```

Support and other resources

Contacting HP

For worldwide technical support information, see the HP support website:

<http://www.hp.com/support>

Before contacting HP, collect the following information:

- Product model names and numbers
- Technical support registration number (if applicable)
- Product serial numbers
- Error messages
- Operating system type and revision level
- Detailed questions

Subscription service

HP recommends that you register your product at the Subscriber's Choice for Business website:

<http://www.hp.com/go/wwalerts>

After registering, you will receive email notification of product enhancements, new driver versions, firmware updates, and other product resources.

Related information

Documents

To find related documents, browse to the Manuals page of the HP Business Support Center website:

<http://www.hp.com/support/manuals>

- For related documentation, navigate to the Networking section, and select a networking category.
- For a complete list of acronyms and their definitions, see *HP FlexNetwork Technology Acronyms*.

Websites

- HP.com <http://www.hp.com>
- HP Networking <http://www.hp.com/go/networking>
- HP manuals <http://www.hp.com/support/manuals>
- HP download drivers and software <http://www.hp.com/support/downloads>
- HP software depot <http://www.software.hp.com>
- HP Education <http://www.hp.com/learn>

Conventions

This section describes the conventions used in this documentation set.





Command conventions

Convention	Description
Boldface	Bold text represents commands and keywords that you enter literally as shown.
<i>Italic</i>	<i>Italic</i> text represents arguments that you replace with actual values.
[]	Square brackets enclose syntax choices (keywords or arguments) that are optional.
{ x y ... }	Braces enclose a set of required syntax choices separated by vertical bars, from which you select one.
[x y ...]	Square brackets enclose a set of optional syntax choices separated by vertical bars, from which you select one or none.
{ x y ... } *	Asterisk-marked braces enclose a set of required syntax choices separated by vertical bars, from which you select at least one.
[x y ...] *	Asterisk-marked square brackets enclose optional syntax choices separated by vertical bars, from which you select one choice, multiple choices, or none.
&<1-n>	The argument or keyword and argument combination before the ampersand (&) sign can be entered 1 to n times.
#	A line that starts with a pound (#) sign is comments.











GUI conventions

Convention	Description
Boldface	Window names, button names, field names, and menu items are in bold text. For example, the New User window appears; click OK .
>	Multi-level menus are separated by angle brackets. For example, File > Create > Folder .

Symbols

Convention	Description
 WARNING	An alert that calls attention to important information that if not understood or followed can result in personal injury.
 CAUTION	An alert that calls attention to important information that if not understood or followed can result in data loss, data corruption, or damage to hardware or software.
 IMPORTANT	An alert that calls attention to essential information.
NOTE	An alert that contains additional or supplementary information.
 TIP	An alert that provides helpful information.

Network topology icons

	Represents a generic network device, such as a router, switch, or firewall.
	Represents a routing-capable device, such as a router or Layer 3 switch.
	Represents a generic switch, such as a Layer 2 or Layer 3 switch, or a router that supports Layer 2 forwarding and other Layer 2 features.
	Represents an access controller, a unified wired-WLAN module, or the switching engine on a unified wired-WLAN switch.
	Represents an access point.
	Represents a mesh access point.
	Represents omnidirectional signals.
	Represents directional signals.
	Represents a security product, such as a firewall, UTM, multiservice security gateway, or load-balancing device.
	Represents a security card, such as a firewall, load-balancing, NetStream, SSL VPN, IPS, or ACG card.

Port numbering in examples

The port numbers in this document are for illustration only and might be unavailable on your device.

Appendix A Chassis views and technical specifications

Chassis views

1920-8G

Figure 24 1920-8G front panel

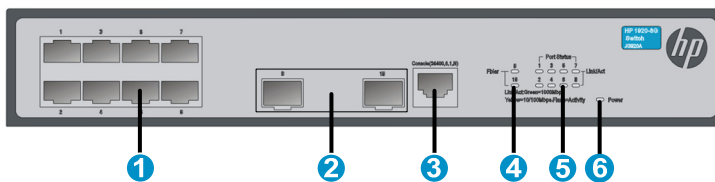

(1) 10/100/1000BASE-T copper ports	(2) 100/1000BASE-X SFP fiber ports
(3) Console port	(4) Fiber port LEDs
(5) Copper port LEDs	(6) Power LED

Figure 25 1920-8G rear panel

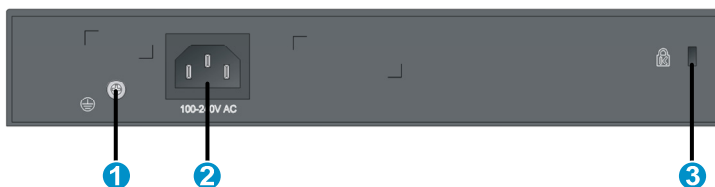

(1) Grounding screw	(2) AC power receptacle
(3) Security slot	

1920-16G

Figure 26 1920-16G front panel

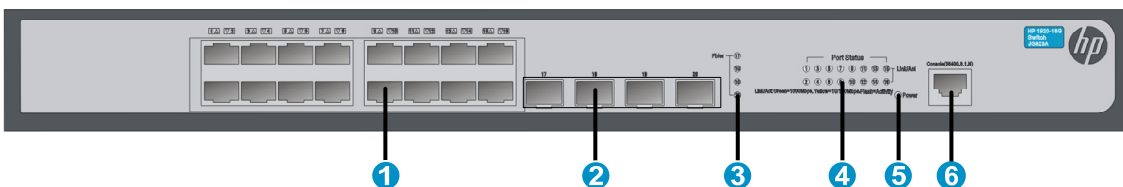

(1) 10/100/1000BASE-T copper ports	(2) 100/1000BASE-X SFP fiber ports
(3) Fiber port LEDs	(4) Copper port LEDs
(5) Power LED	(6) Console port

Figure 27 1920-16G rear panel



(1) Grounding screw

(2) AC power receptacle

1920-24G

Figure 28 1920-24G front panel

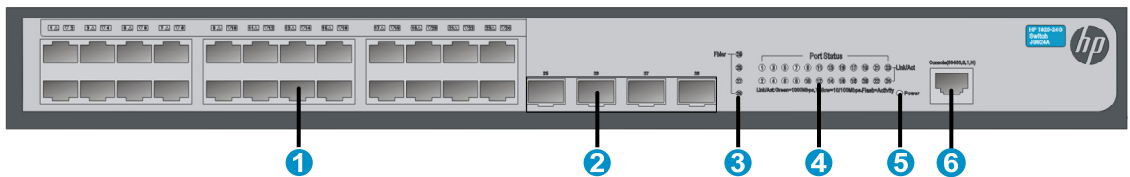

(1) 10/100/1000BASE-T copper ports

(2) 100/1000BASE-X SFP fiber ports

(3) Fiber port LEDs

(4) Copper port LEDs

(5) Power LED

(6) Console port

Figure 29 1920-24G rear panel

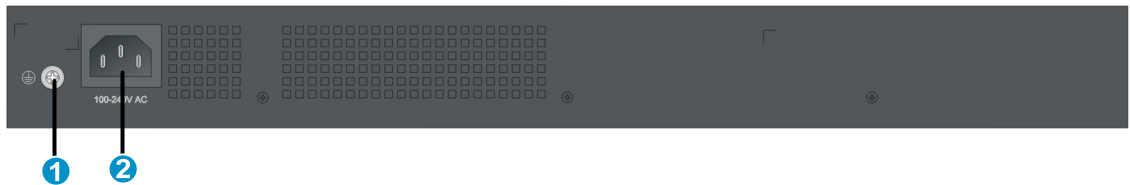

(1) Grounding screw

(2) AC power receptacle

1920-48G

Figure 30 1920-48G front panel

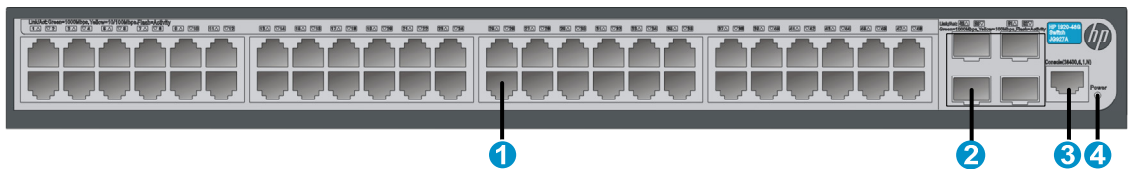

(1) 10/100/1000BASE-T copper ports

(2) 100/1000BASE-X SFP fiber ports

(3) Console port

(4) Power LED

Figure 31 1920-48G rear panel



- | | |
|---------------------|-------------------------|
| (1) Grounding screw | (2) AC power receptacle |
|---------------------|-------------------------|

1920-8G-PoE+ (65W)

Figure 32 1920-8G-PoE+ (65W) front panel

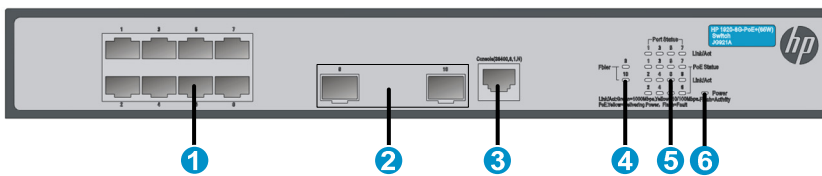

- | | |
|------------------------------------|------------------------------------|
| (1) 10/100/1000BASE-T copper ports | (2) 100/1000BASE-X SFP fiber ports |
| (3) Console port | (4) Fiber port LEDs |
| (5) Copper port LEDs | (6) Power LED |

Figure 33 1920-8G-PoE+ (65W) rear panel

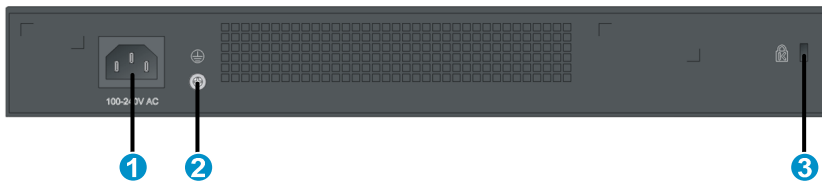

- | | |
|-------------------------|---------------------|
| (1) AC power receptacle | (2) Grounding screw |
| (3) Security slot | |

1920-8G-PoE+ (180W)

Figure 34 1920-8G-PoE+ (180W) front panel

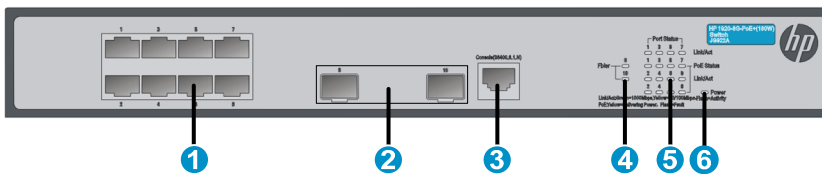

- | | |
|------------------------------------|------------------------------------|
| (1) 10/100/1000BASE-T copper ports | (2) 100/1000BASE-X SFP fiber ports |
| (3) Console port | (4) Fiber port LEDs |
| (5) Copper port LEDs | (6) Power LED |

Figure 35 1920-8G-PoE+ (180W) rear panel



- | | |
|-------------------------|---------------------|
| (1) AC power receptacle | (2) Grounding screw |
| (3) Security slot | |

1920-24G-PoE+ (180W)

Figure 36 1920-24G-PoE+ (180W) front panel

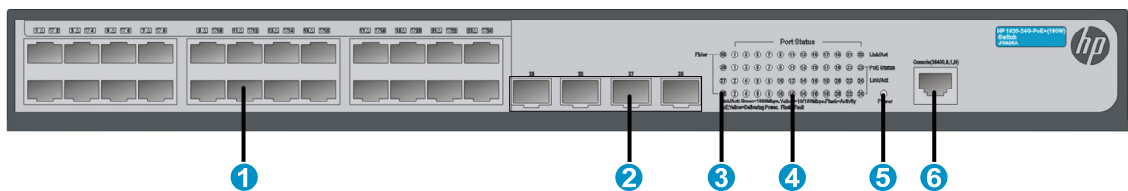

- | | |
|------------------------------------|------------------------------------|
| (1) 10/100/1000BASE-T copper ports | (2) 100/1000BASE-X SFP fiber ports |
| (3) Fiber port LEDs | (4) Copper port LEDs |
| (5) Power LED | (6) Console port |

Figure 37 1920-24G-PoE+ (180W) rear panel



- | | |
|---------------------|-------------------------|
| (1) Grounding screw | (2) AC power receptacle |
|---------------------|-------------------------|

1920-24G-PoE+ (370W)

Figure 38 1920-24G-PoE+ (370W) front panel

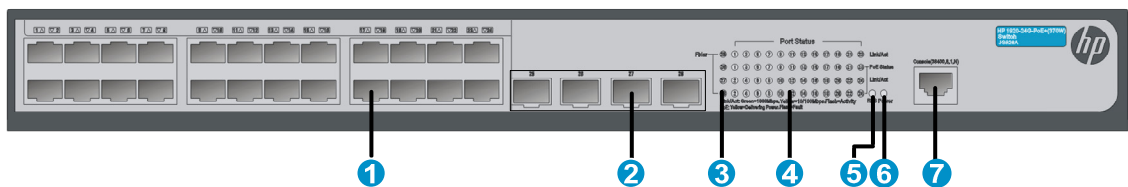

- | | |
|--|------------------------------------|
| (1) 10/100/1000BASE-T copper ports | (2) 100/1000BASE-X SFP fiber ports |
| (3) Fiber port LEDs | (4) Copper port LEDs |
| (5) Redundant power system (RPS) power LED | (6) Power LED |
| (7) Console port | |

Figure 39 1920-24G-PoE+ (370W) rear panel

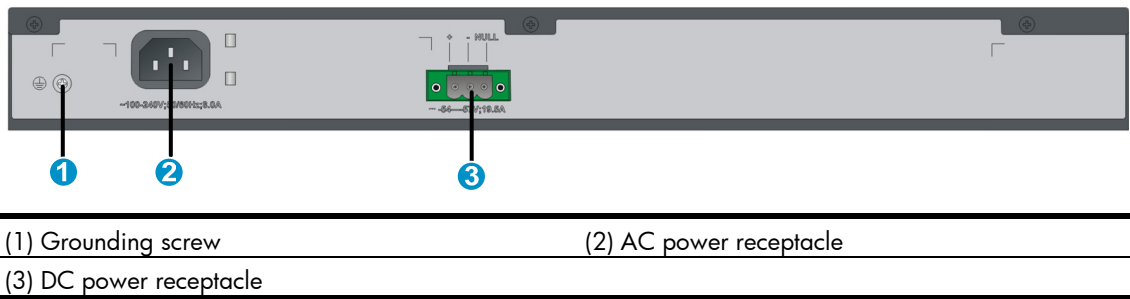

- | | |
|-------------------------|-------------------------|
| (1) Grounding screw | (2) AC power receptacle |
| (3) DC power receptacle | |

Physical specifications

Chassis dimensions and weights

Chassis	Dimensions (H x W x D)	Maximum weight
1920-8G	44 x 266 x 162 mm (1.73 x 10.47 x 6.38 in)	1 kg (2.20 lb)
1920-16G	44 x 440 x 173 mm (1.73 x 17.32 x 6.81 in)	2.1 kg (4.63 lb)
1920-24G	44 x 440 x 173 mm (1.73 x 17.32 x 6.81 in)	2.2 kg (4.85 lb)
1920-8G-PoE+ (65W)	44 x 330 x 230 mm (1.73 x 12.99 x 9.06 in)	2.1 kg (4.63 lb)
1920-8G-PoE+ (180W)	44 x 330 x 230 mm (1.73 x 12.99 x 9.06 in)	2.5 kg (5.51 lb)
1920-24G-PoE+ (180W)	44 x 440 x 238 mm (1.73 x 17.32 x 9.37 in)	3.4 kg (7.50 lb)
1920-24G-PoE+ (370W)	44 x 440 x 260 mm (1.73 x 17.32 x 10.24 in)	4.0 kg (8.82 lb)
1920-48G	44 x 440 x 238 mm (1.73 x 17.32 x 9.37 in)	3.4 kg (7.50 lb)

Ports and interface card slots

Chassis	Console ports	10/100/1000Base-T auto-sensing Ethernet ports	100/1000Base-X SFP ports
1920-8G	1	8	2
1920-16G	1	16	4
1920-24G	1	24	4
1920-8G-PoE+ (180W)	1	8, PoE+	2
1920-8G-PoE+ (65W)	1	8, PoE+	2
1920-24G-PoE+ (370W)	1	24, PoE+	4
1920-24G-PoE+ (180W)	1	24, PoE+	4
1920-48G	1	48	4

Environmental specifications

Chassis	Operating temperature	Relative humidity
All chassis	0°C to 40°C (32°F to 104°F)	5% to 95%, noncondensing

Power specifications

AC input voltage specifications

Chassis	Rated voltage range
All chassis	100 VAC to 240 VAC @ 50 Hz or 60 Hz

RPS DC input voltage specifications and RPS compatibility

Chassis	RPS input rated voltage range
1920-24G-PoE+ (370W)	-54 VDC to -57 VDC

Power consumption specifications for non-PoE switches

Chassis	Minimum power consumption	Maximum power consumption
1920-8G	4 W	8.5 W
1920-16G	5.7 W	13 W
1920-24G	9.5 W	19 W
1920-48G	20 W	32 W

Power consumption specifications for PoE switches

Chassis	Maximum PoE power per port	Maximum PoE ports at full 30 W output	Total PoE output	Minimum power consumption	Maximum power consumption (including total PoE output)
1920-8G-PoE+ (65W)	30 W	2	65 W	6 W	94 W
1920-8G-PoE+ (180W)	30 W	6	180 W	11 W	230 W
1920-24G-PoE+ (180W)	30 W	6	180 W	18 W	235 W

Chassis	Maximum PoE power per port	Maximum PoE ports at full 30 W output	Total PoE output	Minimum power consumption	Maximum power consumption (including total PoE output)
1920-24G-PoE (370W)	30 W	12 at AC input 24 at RPS DC input	370 W at AC input 740 W at RPS DC input	18.5 W at AC input 17 W at RPS DC input	474 W at AC input 834 W at RPS DC input

Cooling system

Chassis	Fixed fans
1920-8G	
1920-8G-PoE+ (65W)	
1920-16G	N/A
1920-24G	
1920-48G	1
1920-8G-PoE+ (180W)	
1920-24G-PoE+ (180W)	2
1920-24G-PoE+ (370W)	3

Appendix B LEDs

Power LED

Table 5 Power LED description

Status	Description
Steady green	The switch is powered on and the power supply is operating correctly.
Flashing green	The switch is powered on and is performing the self-test.
Off	The switch is not powered on or the power supply is faulty.

Copper port LEDs

Link/ACT LEDs

Table 6 Link/ACT LED description

Status	Description
Steady yellow	A 10/100-Mbps link is present.
Flashing yellow	The port is receiving or sending data at 10/100 Mbps.
Steady green	A 1000-Mbps link is present.
Flashing green	The port is receiving or sending data at 1000 Mbps.
Off	No link is present.

PoE LEDs

Table 7 PoE LED description

Status	Description
Steady yellow	The port is supplying power correctly.
Flashing yellow	The port is supplying power incorrectly.
Off	The port is not supplying power.

Fiber port LEDs

Table 8 SFP port LED description

Status	Description
Steady yellow	A 100-Mbps link is present.
Flashing yellow	The port is receiving or sending data at 100 Mbps.

Status	Description
Steady green	A 1000-Mbps link is present.
Flashing green	The port is receiving or sending data at 1000 Mbps.
Off	No link is present.

RPS LED

Only the HP 1920-24G-PoE+ (370W) supports the RPS.

Table 9 RPS power LED description

Status	Description
Steady green	The RPS is supplying power correctly.
Off	No RPS is used or the RPS is supplying power incorrectly.

Appendix C Troubleshooting

Table 10 describes the troubleshooting methods for common issues that you might encounter while using and managing the switch.

If a problem persists, contact HP Support.

Table 10 Troubleshooting methods

Symptom	Troubleshooting method
Power LED off	<ol style="list-style-type: none">1. Verify that the correct power source is used and the power cords are correctly connected.2. Verify that the power source side provides power supply correctly.
LAN interface LED off	<ol style="list-style-type: none">1. Verify that the network cable is correctly connected to the network port of the switch.2. Insert the two ends of a network cable into two network ports of the switch. If the port LEDs are off, replace the network cable.
Unable to log in to the Web interface of the HP 1920 switch	<ol style="list-style-type: none">1. Ping 127.0.0.1 to verify that TCP/IP has been installed.2. Ping the management IP address of the switch to verify that the management PC is connected to the switch. If not, perform the following check:<ul style="list-style-type: none">o For local configuration, verify that the IP addresses of the management PC and the switch are in the same subnet.o For remote configuration, verify that the route from the management PC to the switch is reachable.3. Identify the LED status to verify that the cables are connected correctly.4. Verify that the switch's port that connects to the management PC is enabled and belongs to the management VLAN.5. Verify that the Web browser is not configured with proxy or dial-up connection.6. Disable and then enable the local network after you complete local network settings.