



COLOR LASERJET ENTERPRISE CP4020/CP4520 SERIES PRINTER

Software Technical Reference



CP4025n
CP4025dn
CP4525n
CP4525dn
CP4525xh



HP Color LaserJet Enterprise CP4020- CP4520 Series

Software Technical Reference

Copyright and license

© 2009 Copyright Hewlett-Packard Development Company, L.P.

Reproduction, adaptation or translation without prior written permission is prohibited, except as allowed under the copyright laws.

The information contained herein is subject to change without notice.

The only warranties for HP products and services are set forth in the express warranty statements accompanying such products and services. Nothing herein should be construed as constituting an additional warranty. HP shall not be liable for technical or editorial errors or omissions contained herein.

Edition 1, 10/2009

Trademark credits

Adobe®, Acrobat®, and PostScript® are trademarks of Adobe Systems Incorporated.

ENERGY STAR and the ENERGY STAR mark are registered U.S. marks.

FireWire® FireWire is a trademark of Apple Computer, Inc., registered in the U.S. and other countries.

Microsoft®, Windows®, Windows® XP, and Windows Vista® are U.S. registered trademarks of Microsoft Corporation.

PANTONE® is Pantone, Inc's check-standard trademark for color.

Intel® Core™ is a trademark of Intel Corporation in the U.S. and other countries.

Java™ is a US trademark of Sun Microsystems, Inc.

UNIX® is a registered trademark of The Open Group.

Table of contents

1 Purpose and scope	1
Introduction	1
Product overview	3
Product comparison	5
Documentation availability	6
User documentation	7
HP Color LaserJet Enterprise CP4020-CP4520 Series User Guide	7
HP Color LaserJet Enterprise CP4020-CP4520 Series Install Notes	8
Show Me How	9
Administrator documentation	9
HP Jetdirect Administrator's Guide	10
Color Printing Access and Usage	11
HP Driver Configuration User Guide	11
Software availability and localization	12
Printing-system software on the Web	12
In-box printing-system software CD	12
HP LaserJet software CD, Windows partition	12
CD versions and language support	13
Product views	17
Front view	17
Back view	18
Interface ports	19
Serial number and model number location	19
2 Windows software description	21
Introduction	21
Windows printing-system software	22
Printing system and installer	22
HP Color LaserJet Enterprise CP4020-CP4520 Series printing-system software CD for Windows systems	22
Installer features	24
HP Color LaserJet print drivers	25
HP PCL 6 Print Driver, PCL 5 Universal Print Driver, and PS Universal Print Driver	25

Print-driver version numbers for Windows operating systems	25
Driver configuration for Windows	27
Driver autoconfiguration	27
Bidirectional communication	27
Enterprise AutoConfiguration	27
Update Now	29
HP Driver Configuration	30
Lockable features	31
Continuous export	32
HP Driver Diagnostic Printer Check Tool	33
Advanced color use	34
Color Access Control	34
International Color Consortium profiles	35
PANTONE color profiles	35
HP Easy Printer Care	35
HP Embedded Web Server	35
HP Web Jetadmin	36
Font support	37
Basic fonts	37
Default fonts	37
HP Driver Deployment Utility	43
3 Install Windows software and utilities	53
Introduction	53
Supported operating systems for Windows	54
System requirements	54
Print driver support in other operating systems	55
General Microsoft Windows installation instructions	56
Microsoft Windows installation for direct connections	56
Install from the printing-system CD	56
Install the print driver using the Microsoft Add Printer Wizard	56
Use an existing port for a direct connection	57
Create a new TCP/IP port for a direct connection	63
Print sever connection	66
Microsoft Windows installation for computers on a network	70
Point and Print installation for Windows	76
Detailed Microsoft Windows installation instructions	78
Perform the recommended print driver installation using the HP Driver Installation Utility (HPDIU)	78
Use the Back, Next, Finish, and Cancel buttons	86
Performing an advanced print driver installation using the HP Driver Installation Utility (HPDIU)	87
Set a default printer	96
Uninstall instructions	97

4 HP PCL 6 print driver and HP PS Universal Print Driver for Windows	99
Introduction	99
Change printer-driver settings for Windows	100
Change the settings for all print jobs until the software program is closed	100
Change the default settings for all print jobs	100
Change the product configuration settings	100
Access print drivers	100
Printing Preferences driver tabs	101
Properties driver tabs	102
Help system	103
“What's this?” Help	103
Incompatible Print Settings messages	103
Advanced tab features	105
Paper/Output	105
Copy Count	106
Graphic	106
Image Color Management	106
True Type Font	106
Document Options	106
Advanced Printing Features	107
Print Optimizations	107
Printer Features	107
Layout Options	108
Printing Shortcuts tab features	109
Use defined printing shortcuts	110
Factory Defaults	110
General Everyday Printing	110
Paper type	111
Paper sizes	112
Paper source	113
Orientation	113
Print on both sides	113
Pages per sheet	114
Eco-print (Two-sided Printing)	114
Two-sided (Duplex) Printing	114
Cardstock Heavy	114
Glossy/Presentation	115
Create a custom printing shortcut	115
Paper/Quality tab features	116
Paper Options	117
Paper sizes	117
Custom Paper Size	118
Name	118
Paper size	119

Units	119
Custom width and height control limits	119
Paper source	120
Paper type	120
Special pages	122
Covers	122
Print pages on different paper	123
Insert blank or preprinted pages	123
Chapter separator pages	124
Document preview image	125
Print Quality	126
Print Quality drop-down menu	126
Effects tab features	127
Resizing Options	127
Actual Size	128
Print Document On	128
Scale to Fit	128
% of Actual Size	128
Document preview image	129
Watermarks	129
Current watermarks	131
Watermark Message	131
Message Angle	131
Font Attributes	131
Default watermark settings	133
Finishing tab features	134
Document Options	134
Print on Both Sides	135
Print on both sides automatically	135
Print on both sides manually	136
Flip Pages Up	137
Booklet Layout	138
Book and Booklet Printing	138
Pages per Sheet	139
Print Page Borders	139
Page Order	139
Document preview image	140
Orientation	140
Job Storage tab features	142
Status group box	144
Job Storage Mode	144
Off	144
Proof and Hold	144
Personal Job	145

Quick Copy	145
Stored Job	145
PIN to print	146
Job Notification Options	146
User Name	146
Job Name	147
Use job-storage features when printing	147
Release a job-storage print job	148
Delete a job-storage print job	148
Color tab features	149
Color Options	150
Automatic	150
Manual	150
General	152
Neutral Grays	152
Halftone	152
Color Themes	153
Default (sRGB)	153
Photo (sRGB)	153
Photo (Adobe RGB 1998)	153
Vivid (sRGB)	153
None	153
Custom Profile	153
Document preview image	154
HP EasyColor	154
Services tab features	156
Internet Services	156
Device services	157
Device Settings tab features	158
Form to Tray Assignment	158
Font Substitution Table	159
External Fonts	160
Installing external fonts	161
Removing external fonts	162
Installable Options	162
Automatic Configuration	162
Tray 3	163
Tray 4	163
Tray 5	163
Duplex Unit (for 2-Sided Printing)	163
Allow Manual Duplexing	163
Printer Hard Disk	163
Job Storage	163
Job Separator	163

Mopier Mode	164
Mopier mode and collation	164
About tab features	166
5 Macintosh software and utilities	167
Introduction	167
Supported operating systems for Macintosh	168
Macintosh system requirements	168
Hardware requirements	168
Supported printer drivers for Mac	168
Change printer-driver settings for Mac	168
Printing-system software	169
PDEs	169
HP Embedded Web Server	169
Install notes	169
Online help	169
Screen fonts	169
Macintosh installation instructions	170
HP LaserJet software CD, Macintosh partition	170
Install the HP LaserJet printing-system software for the Macintosh OS	170
General installation instructions	170
Mac OS X installation	171
Main Install dialog box sequence	171
Setup instructions	177
Setting up a printer with Mac OS X v10.4, v10.5, and later	177
Troubleshooting the product setup	179
Remove software from Mac operating systems	180
HP Printer Utility for Mac	181
Access to the HP (Printer) Utility	181
Supplies Status	182
Device Information	183
Color Usage	184
File Upload	185
Remote firmware update by using the HP Printer Utility	185
Upload Fonts	187
Duplex mode	188
Trays Configuration	189
Stored Jobs	190
E-mail Alerts	191
Network Settings	192
Supplies Management	194
Protect Direct Ports	195
Additional Settings	196

6 Engineering Details	197
Introduction	197
Remote firmware update	198
Determining the current level of firmware	198
Downloading the new firmware from the HP Web site	198
Downloading the new firmware to the product	198
Printer messages during the firmware update	199
Downloading custom color profiles	201
Remote firmware update by using FTP through a browser	201
Remote firmware update by using FTP on a direct network connection (Windows)	202
Remote firmware update through a local Windows port	203
Windows 2000, Windows XP, Windows Server 2003, or Windows Server 2008	204
Remote firmware update through a USB port	204
Remote firmware update through a Windows network	205
Remote firmware update by using the LPR command	206
HP Easy Firmware Upgrade utility	206
Remote firmware update through HP Web Jetadmin	209
Remote firmware update using HP Web Jetadmin V7.8 or 8.x	209
Remote firmware update using HP Web Jetadmin 10.x	210
Remote firmware update by using FTP on a direct network connection (Macintosh)	211
Remote firmware update using the HP Printer Utility (Macintosh OS X)	211
Remote firmware update for UNIX systems	212
Printing print-ready documents	213
Print-ready file printing by using FTP through a browser	213
Print-ready file printing by using FTP on a direct network connection (Windows)	214
Print-ready printing by using a local Windows port	214
Windows 2000, Windows XP, Windows Server 2003, Windows Server 2008, or Windows Vista	215
Print-ready file printing in a Windows network	215
Print-ready file printing by using the LPR command	215
Print-ready file printing by using FTP on a direct network connection (Macintosh)	216
Print-ready file printing in UNIX systems	217
Special paper guidelines	218
Media attributes and commands	219
Paper-source commands	219
Paper-type commands	220
Installation notes	221
I. INTRODUCTION	221
PURPOSE OF THIS DOCUMENT	221
WHO NEEDS THIS SOFTWARE?	221
SYSTEM REQUIREMENTS	221
OVERVIEW OF THE PRINTING-SYSTEM COMPONENTS	222
Network administrator software components	222

End-user software components	222
Product documentation	223
II. LATE-BREAKING INFORMATION	223
KNOWN ISSUES, ISSUES FIXED, AND WORKAROUNDS	223
III. INSTALLATION INSTRUCTIONS	224
WINDOWS INSTALLATION OPTIONS	224
INSTALL SOFTWARE ON WINDOWS XP, WINDOWS SERVER 2003, WINDOWS SERVER 2008, WINDOWS VISTA, AND WINDOWS 7 SYSTEMS	224
Printing-system installation from the CD or Internet download for network and USB connections	224
Port selection	224
Printer driver only (Add Printer) - Windows XP, Windows Server 2003, and Windows Server 2008	225
Printer driver only (Add Printer) - Windows Vista and Windows 7	225
UNINSTALLER	226
Start the Uninstaller - Windows XP, Windows Server 2003, and Windows Server 2008	226
Start the Uninstaller - Windows Vista and Windows 7	226
INSTALL MACINTOSH SOFTWARE FOR DIRECT CONNECTIONS (USB)	226
INSTALL MACINTOSH SOFTWARE FOR NETWORKS	227
IV. TECHNICAL ASSISTANCE	228
CUSTOMER SUPPORT	228
WEB	228
HP SOFTWARE AND SUPPORT SERVICES - ADDITIONAL INFORMATION	228
V. LEGAL STATEMENTS	228
OPEN-SOURCE SOFTWARE LICENSE AGREEMENTS (In English)	228
Apache License	228
TRADEMARK NOTICES	231
SOFTWARE WARRANTY, LICENSE, AND COPYRIGHT	231
Warranty	231
License	231
Copyright	231
Index	233

List of tables

Table 1-1	Software technical reference overview	1
Table 1-2	Documentation availability	6
Table 1-3	Software CD supported languages	13
Table 1-4	Supported printer driver languages	14
Table 1-5	Installer component languages	15
Table 1-6	Documentation languages	16
Table 2-1	Automatic discovery and driver configuration through bidirectional communication ¹	27
Table 2-2	EAC availability in Microsoft Windows and Microsoft Share	28
Table 2-3	EAC availability in Novell Netware environments	29
Table 2-4	Operating systems that support HP Driver Preconfiguration	32
Table 2-5	Color access control tools	34
Table 2-6	Default fonts	37
Table 2-7	Additional PS emulation fonts	39
Table 4-1	PCL 6 custom paper sizes	119
Table 4-2	Font Attribute settings for new and preset watermarks	133
Table 4-3	Page orientation	138
Table 4-4	Driver mopier mode and collation settings	164
Table 5-1	Adding a product in Macintosh operating systems	171
Table 6-1	Troubleshooting a firmware update	199
Table 6-2	Troubleshooting a firmware update failure	199
Table 6-3	Update messages	200
Table 6-4	Paper-source commands ¹	219
Table 6-5	paper-type commands	220

List of figures

Figure 1-1	Installation software CD – User Documentation screen	7
Figure 1-2	Installation software CD – Administrator Documentation screen	10
Figure 2-1	Installation software CD browser	23
Figure 2-2	Package Source	45
Figure 2-3	Network Settings	46
Figure 2-4	HP DDU Driver Configuration settings	48
Figure 3-1	Add Printer Wizard — Local or Network Printer screen	57
Figure 3-2	Add Printer Wizard — Select a Printer Port screen	58
Figure 3-3	Add Printer Wizard — Install Printer Software screen	59
Figure 3-4	Add Printer Wizard — Install from Disk screen	59
Figure 3-5	Add Printer Wizard — Install Printer Software, screen 2	60
Figure 3-6	Add Printer Wizard — Name Your Printer screen	61
Figure 3-7	Add Printer Wizard — Printer Sharing screen	62
Figure 3-8	Add Printer Wizard — Print Test Page screen	63
Figure 3-9	Local or Network Printer screen	64
Figure 3-10	Select a Printer Port screen	65
Figure 3-11	Add Standard TCP/IP Printer Port screen	65
Figure 3-12	Add Port screen	66
Figure 3-13	Add Printer Wizard — Local or Network Printer screen	67
Figure 3-14	Add Printer Wizard — Specify A Printer screen	68
Figure 3-15	Add Printer Wizard — Find Printers screen	69
Figure 3-16	Add Printer Wizard — Default Printer screen	69
Figure 3-17	Add Printer Wizard — Browse for Printer screen	70
Figure 3-18	Software Installation — License Agreement screen	71
Figure 3-19	Software Installation — Device Connection screen	72
Figure 3-20	Device Connection — Devices Found screen	73
Figure 3-21	Software Installation — Device Connection screen 2	74
Figure 3-22	Software Installation — Driver Installation Complete screen 1	75
Figure 3-23	Software Installation — Driver Installation Complete screen 2	76
Figure 3-24	Software Installation — Initial screen	79
Figure 3-25	Software Installation — License Agreement screen	80
Figure 3-26	Software Installation — Device Connection screen	81
Figure 3-27	Software Installation — Devices Found screen	82
Figure 3-28	Software Installation — Device Connection screen 2	83

Figure 3-29	Software Installation — Driver Installation Complete screen 1	84
Figure 3-30	Software Installation — Driver Installation Complete screen 2	85
Figure 3-31	Additional Options	86
Figure 3-32	Installation Cancelled dialog box	87
Figure 3-33	Software Installation — Initial screen	88
Figure 3-34	Software Installation — Advanced Installation Options screen	89
Figure 3-35	Software Installation — License Agreement screen	90
Figure 3-36	Software Installation — Device Connection screen	91
Figure 3-37	Software Installation — Devices Found	92
Figure 3-38	Software Installation — Device Connection screen 2	93
Figure 3-39	Software Installation — Driver Installation Complete screen	94
Figure 3-40	Software Installation — Driver Installation Complete screen 2	95
Figure 3-41	Software Installation — Additional Options screen	96
Figure 3-42	Uninstall	97
Figure 4-1	An Incompatible Print Settings message	103
Figure 4-2	The default appearance of the Advanced tab	105
Figure 4-3	Printing Shortcuts tab	109
Figure 4-4	Printing Shortcuts dialog box	115
Figure 4-5	Paper/Quality tab	116
Figure 4-6	Paper Options group box	117
Figure 4-7	Custom Paper Size dialog box	118
Figure 4-8	Print pages on different paper	123
Figure 4-9	Insert blank or preprinted pages	124
Figure 4-10	Chapter separator pages	125
Figure 4-11	Effects tab	127
Figure 4-12	Preview images – Legal on Letter; Scale to Fit off (left) and on (right)	128
Figure 4-13	Watermark Details dialog box	130
Figure 4-14	Finishing tab	134
Figure 4-15	Print on Both Sides Instructions dialog box	137
Figure 4-16	Page-order preview images	140
Figure 4-17	Job Storage tab	143
Figure 4-18	Color tab	149
Figure 4-19	Color Settings dialog box	151
Figure 4-20	Services tab	156
Figure 4-21	Device Settings tab	158
Figure 4-22	Font Substitution Table	160
Figure 4-23	HP Font Installer dialog box	161
Figure 4-24	About tab	166
Figure 5-1	Mac installer opening screen	172
Figure 5-2	Mac installer Introduction dialog	173
Figure 5-3	Mac installer License dialog	173
Figure 5-4	Mac installer license agreement dialog	174
Figure 5-5	Mac installer Installation Type dialog	174
Figure 5-6	Mac installer custom installation dialog	175

Figure 5-7	Mac installer authentication dialog	176
Figure 5-8	Mac installer Installation dialog	176
Figure 5-9	Mac installer Summary dialog	177
Figure 5-10	HP Utility main screen	182
Figure 5-11	Supplies Status screen	182
Figure 5-12	Device Information screen	183
Figure 5-13	Print Color Usage Job Log screen	184
Figure 5-14	File Upload screen	185
Figure 5-15	Upload Fonts screen	187
Figure 5-16	Duplex Mode screen	188
Figure 5-17	Trays Configuration screen	189
Figure 5-18	Enable Job Storing screen	190
Figure 5-19	E-mail Alerts screen	191
Figure 5-20	IPv4 Settings screen	192
Figure 5-21	Bonjour Settings screen	193
Figure 5-22	Replace Supplies screen	194
Figure 5-23	Protect Direct Ports screen	195
Figure 5-24	Additional Settings screen	196
Figure 6-1	HP Easy Firmware Upgrade utility screen 1	207
Figure 6-2	HP Easy Firmware Upgrade utility screen 2	208
Figure 6-3	HP Easy Firmware Upgrade utility progress screen	208
Figure 6-4	HP Easy Firmware Upgrade utility complete screen	209

1 Purpose and scope

Introduction

This software technical reference (STR) provides information about and troubleshooting tips for the HP Color LaserJet Enterprise CP4020-CP4520 Series printing-system software.

This STR is prepared in an electronic format to serve as a quick-reference tool for Customer Care Center (CCC) agents, support engineers, system administrators, information technology (IT) personnel, and HP Color LaserJet Enterprise CP4020-CP4520 Series product end users, as appropriate.

The following information is included:

- Descriptions of drivers and platforms, with system modifications
- Procedures for installing and uninstalling software components
- Descriptions of various topics that are associated with the HP Color LaserJet Enterprise CP4020-CP4520 Series product, including engineering details

The following table describes the structure of this STR.

Table 1-1 Software technical reference overview

Chapter	Content
Chapter 1, Purpose and scope	<p>This chapter contains basic information about the HP Color LaserJet Enterprise CP4020-CP4520 Series product and its software:</p> <ul style="list-style-type: none">• Overview of the HP Color LaserJet Enterprise CP4020-CP4520 Series product• Printing-system software overview, including the following topics:<ul style="list-style-type: none">◦ System requirements◦ Supported operating systems◦ Availability• HP LaserJet software documentation

Table 1-1 Software technical reference overview (continued)

Chapter	Content
Chapter 2, Software description	<p>This chapter provides an overview of the printing-system software installer and print drivers.</p> <p>This chapter also contains general information about optional software features.</p> <p>The following topics are included:</p> <ul style="list-style-type: none">• Driver configuration for Windows®• International Color Consortium (ICC) profiles• PANTONE® color profiles• HP Easy Printer Care• HP Embedded Web Server• HP Web Jetadmin
Chapter 3, Installing Windows printing-system components	<p>This chapter provides instructions for installing the HP Color LaserJet Enterprise CP4020-CP4520 Series product in Windows operating systems by using various installation methods.</p>
Chapter 4, HP PCL 6 Print Driver for Windows	<p>This chapter provides detailed descriptions of the HP PCL 6 Print Driver for Windows® XP, Windows Server 2003, Windows Server 2008, Windows Vista®, and Windows 7®.</p> <p>This chapter also contains information about using job-storage features when printing, including the following topics:</p> <ul style="list-style-type: none">• Releasing a job-storage print job• Deleting a job-storage print job
Chapter 5, HP Universal Print Drivers for Windows – PS and PCL 5	<p>This chapter provides detailed descriptions of the HP PostScript (PS) Universal Print Driver and the HP PCL 5 Universal Print Driver for Windows XP, Windows Server 2003, Windows Server 2008, Windows Vista, and Windows 7.</p>
Chapter 6, Macintosh software and utilities	<p>This chapter provides Instructions for installing the HP Color LaserJet Enterprise CP4020-CP4520 Series product in Macintosh operating systems and information about the printing-system software. The HP Printer Utility for Macintosh is also described.</p>
Chapter 7, Engineering details	<p>This chapter contains information about the following special topics:</p> <ul style="list-style-type: none">• Remote firmware update• Printing print-ready documents• Media attributes

For additional information about the location of information within these chapters, see the table of contents. An index is provided in the back of this STR.

Additional detailed information about the HP Color LaserJet Enterprise CP4020-CP4520 Series printing-system software is published in an addendum to this STR. The following information is available only in the addendum:

- Descriptions of known software issues and solutions
- Printing system reports



Product overview

The following table contains descriptions of the HP Color LaserJet Enterprise CP4020-CP4520 Series product features that are discussed. Product configurations might vary among countries/regions.

Speed and throughput	HP Color LaserJet CP4025 models <ul style="list-style-type: none">• Print up to 35 pages per minute (ppm) on letter-size paper and 35 ppm on A4-size paper.• As quick as 10 seconds to print the first page• Recommended monthly print volume of 2,000 to 7,500 pages• A 800 megahertz (MHz) microprocessor HP Color LaserJet CP4525 models <ul style="list-style-type: none">• Print up to 42 pages per minute (ppm) on letter-size paper and 40 ppm on A4-size paper.• As quick as 10 seconds to print the first page• Recommended monthly print volume of 2,500 to 10,000 pages• A 800 megahertz (MHz) microprocessor
Resolution	<ul style="list-style-type: none">• 1200 dots per inch (dpi) with HP Image Resolution Enhancement technology 3600• 1200 x 1200 dpi for detailed line work and small text
Memory	<ul style="list-style-type: none">• n and dn models: 512 MB of random-access memory (RAM), expandable to 1 GB by adding into the open DIMM slot 200-pin small outline dual inline memory modules (DDR2 SODIMM) that support 256 MB or 512 MB of RAM.• xh models: 1 gigabyte (GB) of random-access memory (RAM).• Memory Enhancement technology (MEt) automatically compresses data to use RAM more efficiently.
User interface	<ul style="list-style-type: none">• Four-line color graphical display on the control panel• HP Embedded Web Server to configure and manage the product remotely from any computer connected to the same network
Paper-handling	<ul style="list-style-type: none">• Tray 1 (multipurpose tray): A multipurpose tray for paper, transparencies, labels, envelopes, and other paper types. The tray holds up to 100 sheets of paper, 50 transparencies, or 10 envelopes.• Tray 2: 500-sheet tray, and an optional HP Postcard media insert.• Optional Trays 3, 4 and 5: 500-sheet trays• Two-sided printing: The dn and xh models support automatic two-sided printing. The other models support manual two-sided printing.• Standard output bin: Hold up to 500 sheets of paper. The product has a sensor that indicates when the bin is full.
Languages and fonts	<ul style="list-style-type: none">• HP Printer Control Language PCL 5, PCL 6, and HP postscript level 3 emulation• Direct PDF• 93 scalable TrueType typefaces

Print cartridges	<ul style="list-style-type: none"> • For information regarding print cartridges, see www.hp.com/go/learnaboutsupplies. • Authentic HP print cartridge detection • Automatic toner strip remover
Supported operating systems	<ul style="list-style-type: none"> • Microsoft® Windows® XP, Windows Vista®, Windows® Server 2003, Windows® Server 2008, and Windows® 7 • Macintosh OS X 10.4, 10.5, 10.6, and later • Novell NetWare V6.5 and iPrint V5.12 and later • Citrix <ul style="list-style-type: none"> ◦ Citrix Presentation Server 4.0 and 4.5 ◦ Citrix XenApp Server 5.0 ◦ Windows 2003 and 2008 Terminal Services • UNIX® • Linux
Connectivity	<ul style="list-style-type: none"> • Hi-Speed USB 2.0 connection • Local area network (LAN) Ethernet (RJ-45) connector for the embedded HP Jetdirect print server • One enhanced input/output (EIO) slot
Environment	<ul style="list-style-type: none"> • Sleep setting saves energy • High content of recyclable components and materials • Instant-on fuser saves energy
Security	<ul style="list-style-type: none"> • Security lock (optional) • Job retention • User PIN authentication for stored jobs • IPsec security • HP encrypted High Performance EIO hard drive (included with the xh model, and available as an optional accessory for the other models)
Self-help	<ul style="list-style-type: none"> • Show-me-how pages that you can print from the control panel • Job aids for specific tasks available from www.hp.com/support/cljcp4025 or www.hp.com/support/cljcp4525. • Animations and help on the control panel
Accessibility	<ul style="list-style-type: none"> • The online user guide is compatible with text screen-readers. • The print cartridges can be installed and removed by using one hand. • All doors and covers can be opened by using one hand. • Paper can be loaded in Tray 1 by using one hand.

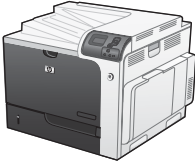
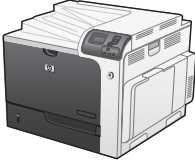
Product comparison

Model	Features
HP Color LaserJet CP4025n	<ul style="list-style-type: none"> • 100-sheet multipurpose input tray (Tray 1)
HP Color LaserJet CP4525n	<ul style="list-style-type: none"> • 500-sheet input tray (Tray 2) • 500-sheet, face-down output bin • Hi-speed USB 2.0 port • HP Jetdirect embedded print server for connecting to a 10/100/1000Base-TX network • 512 megabytes (MB) of random access memory (RAM)
	
HP Color LaserJet CP4025dn	<ul style="list-style-type: none"> • 100-sheet multipurpose input tray (Tray 1)
HP Color LaserJet CP4525dn	<ul style="list-style-type: none"> • 500-sheet input tray (Tray 2) • 500-sheet, face-down output bin • Hi-speed USB 2.0 port • HP Jetdirect embedded print server for connecting to a 10/100/1000Base-TX network • 512 megabytes (MB) of random access memory (RAM) • Automatic two-sided printing
	
HP Color LaserJet CP4525xh	<ul style="list-style-type: none"> • 100-sheet multipurpose input tray (Tray 1) • 500-sheet input tray (Tray 2) • HP 3x500-sheet paper feeder (Trays 3, 4, and 5) • 500-sheet, face-down output bin • Hi-speed USB 2.0 port • HP Jetdirect embedded print server for connecting to a 10/100/1000Base-TX network • 1 gigabyte (GB) of random access memory (RAM) • Automatic two-sided printing • HP Encrypted High Performance Hard Disk
	

Documentation availability

 **NOTE:** For information about language support for the HP Color LaserJet Enterprise CP4020-CP4520 Series product, see [CD versions and language support on page 13](#).

The following table lists the availability of HP Color LaserJet Enterprise CP4020-CP4520 Series printing-system documentation by operating system.

Table 1-2 Documentation availability

Document	Windows XP/Server 2003/Server 2008/Vista/7	Macintosh
<i>HP Color LaserJet Enterprise CP4020-CP4520 Series User Guide (.PDF file)</i>	x	x
<i>HP Color LaserJet Enterprise CP4020-CP4520 Series Install Notes</i>	x	
<i>Show Me How content</i>	x	
<i>HP Jetdirect Administrator's Guide</i>	x	x
<i>Color Printing Access and Usage</i>	x	
<i>HP Driver Preconfiguration User Guide</i>	x	

Access to HP LaserJet documents depends on the type of document and its location:

- Some documents can be opened from the CD Browser.
- Some documents appear on the software CD and can be opened by navigating to the folder where they reside.
- Some documents are available on the Web through links in the CD Browser or CD folders.

Documents are available in the following file formats:

- **Portable Document Format (.PDF).** The HP Color LaserJet Enterprise CP4020-CP4520 Series printing-system software CD includes Adobe® Acrobat® Reader for viewing online documentation.
- **Compiled HTML (.CHM).** When you click a documentation link to a .CHM document, a Microsoft HTML Viewer opens the file on the computer screen.
- **Hypertext Markup (.HTM).** When you click a documentation link to an .HTM document, a Web browser opens the file on the computer screen.
- **Rich Text Format (.RTF).** This is a text file. You can navigate to files and open them in Microsoft Word or Microsoft WordPad.

Documentation for the HP Color LaserJet Enterprise CP4020-CP4520 Series is divided into the following categories:

- [User documentation](#)
- [Administrator documentation](#)

User documentation

The following figure shows the **User Documentation** screen, which appears when you click **User Documentation** on the main screen of the HP Color LaserJet Enterprise CP4020-CP4520 Series printing-system software CD.

Figure 1-1 Installation software CD – User Documentation screen



HP Color LaserJet Enterprise CP4020-CP4520 Series User Guide

The *HP Color LaserJet Enterprise CP4020-CP4520 Series User Guide* describes the basic product features.

To view this guide from the software CD, follow these steps:

1. In the main screen of the CD browser, click the **User Documentation** button.
2. Click the **User Guide (Web)** button.

The guide opens as a PDF file.

 **NOTE:** The version of this guide on the CD is a basic version. The version of this guide available on the Web is the most up-to-date version.

You can also gain access to the file by following these steps:

1. Insert the software CD into the CD-ROM drive.
2. Navigate to the Manuals\<<language> folder.
3. Open the file that has the appropriate file name:

CP4025_USE_XXWW.PDF

CP4525_USE_XXWW.PDF

 **NOTE:** The "XXWW" in the file name corresponds to the language. For instance, the file name for the French version of the guide is CP4525_USE_FRWW.CHM

The *HP Color LaserJet Enterprise CP4020-CP4520 Series User Guide* is provided as a .PDF file, which is viewable with Adobe Reader and which you can print. To print the guide, follow these steps:

1. In the main screen of the CD browser, click the **User Documentation** button.
2. Click the **User Guide (CD)** button. The guide opens.
3. In Adobe Acrobat, click the **File** menu, and then click the **Print** menu item.
4. Select a printer, configure the driver if necessary, and then click the **Print** button

You can also gain access to the file by following these steps:

1. Insert the software CD into the CD-ROM drive.
2. Navigate to the Manuals\<<language> folder.
3. Open the file that has the appropriate file name:

CP4025_USE_XXWW.PDF

CP4525_USE_XXWW.PDF

 **NOTE:** The "XXWW" in the file name corresponds to the language. For instance, the file name for the French version of the guide is CP4525_USE_FRWW.PDF

When you have the file open, you can click the **File** menu, and then click the **Save As** menu item to save a copy of the file to another location.

HP Color LaserJet Enterprise CP4020-CP4520 Series Install Notes

The *HP Color LaserJet Enterprise CP4020-CP4520 Series Install Notes* (in .HTM format) contain important information about product features, instructions for installing the printing-system software, and technical assistance.

To view this guide from the software CD, follow these steps:

1. In the main screen of the CD browser, click the **User Documentation** button.
2. Click the **Install Notes** button. The guide opens.

You can also gain access to the file by following these steps:

1. Insert the software CD into the CD-ROM drive.
2. Navigate to the Manuals\<<language> folder.
3. Open the file that has the appropriate file name:

CP4025_INSTALL-NOTE_XXWW.HTM

CP4525_INSTALL-NOTE_XXWW.HTM

 **NOTE:** The "XXWW" in the file name corresponds to the language. For instance, the file name for the French version of the document is CP4525_INSTALL-NOTE_FRWW.HTM.

Show Me How

Click **Show Me How** on the **User Documentation** screen of the CD browser to connect to a Web page that provides step-by-step instructions for performing specific tasks, including clearing jams and loading trays.

 **NOTE:** The **Show Me How** information is only available online. Internet access is required.

Administrator documentation

The following figure shows the **Administrator Documentation** screen.

To navigate to this screen, click the **Advanced Install Options** button on the main screen of the CD browser, and then click the **Administrator Documentation** button.

Figure 1-2 Installation software CD – Administrator Documentation screen



HP Jetdirect Administrator's Guide

The *HP Jetdirect Administrator's Guide* is a network administrator's guide (in .PDF format) that contains information about connecting the product directly to a network.

To view this guide from the software CD, follow these steps:

1. In the main screen of the CD browser, click **Advanced Install Options**, and then click **Administrator Documentation**.
2. Click **HP Jetdirect Guide**.

You can also gain access to the file by following these steps:

1. Insert the software CD into the CD-ROM drive.
2. Navigate to the Manuals\<language> folder.
3. Open the file that has the appropriate file name:

HPJDIAG_XXWW.PDF

 **NOTE:** The "XXWW" in the file name corresponds to the language. In French, the file name is HPJDIAG_FRWW.PDF.

When you have the file open, you can click **File** and then click **Save As** to save a copy of the file to another location.

Color Printing Access and Usage

Use the **Color Printing Access and Usage** option (Internet access required) to enable or disable color printing and to track color usage.

To link to this guide from the software CD, follow these steps:

1. In the main screen of the CD browser, click **Advanced Install Options**, and then click **Administrator Documentation**.
2. Click **Color Printing Access and Usage**.

HP Driver Configuration User Guide

The *HP Driver Preconfiguration User Guide* (in .PDF format) describes how to use the associated software utility, which allows IT administrators to customize print-driver settings before deploying them. For more information about HP driver preconfiguration, see [HP Driver Configuration on page 30](#).

To view this guide from the software CD, follow these steps:

1. In the main screen of the CD browser, click **Advanced Install Options**, and then click **Administrator Documentation**.
2. Click **HP Driver Preconfiguration User Guide**.

You can also gain access to the file by following these steps:

1. Insert the software CD into the CD-ROM drive.
2. Navigate to the Manuals\<>language> folder.
3. Open the file that has the appropriate file name:

PRECONFIG_SUPPORT_XXWW.PDF

 **NOTE:** The "XXWW" in the file name corresponds to the language. In French, the file name is PRECONFIG_SUPPORT_FRWW.PDF.

When you have the file open, you can click **File** and then click **Save As** to save a copy of the file to another location.

Software availability and localization

This section provides information about the availability of the HP Color LaserJet Enterprise CP4020-CP4520 Series printing-system software and related software and firmware. Printing-system software on a CD is available from HP fulfillment centers. For more information, go to the following Web site:

www.hp.com/go/cljcp4025_cdrom or www.hp.com/go/cljcp4525_cdrom

Printing-system software on the Web

All software that is contained on the installation CD is also available on the Web.

Web deployment is the preferred method for obtaining the latest software. The Web site offers an option for automatic e-mail notification about new software releases.

 **NOTE:** This STR describes drivers that are shipped with the printing-system software CD. This STR does *not* describe any drivers that might be released for use by support personnel.

The HP Color LaserJet Enterprise CP4020-CP4520 Series printing-system software is available for download at the following Web site:

www.hp.com/go/cljcp4025_software or www.hp.com/go/cljcp4525_software

In-box printing-system software CD

The software CD for the HP Color LaserJet Enterprise CP4020-CP4520 Series product contains a variety of files for installing the printing-system software on the computer. This section describes the files that are available on the software CD and provides additional information about support and availability.

The HP Color LaserJet Enterprise CP4020-CP4520 Series printing-system software CD is divided into two partitions, one for Windows operating systems and one for Macintosh operating systems.

The files in each partition include documentation files and files that are required in order to install and uninstall the printing-system components.

HP LaserJet software CD, Windows partition

 **NOTE:** For information about the contents of the Macintosh partition of the HP Color LaserJet Enterprise CP4020-CP4520 Series printing-system software CD, see [HP LaserJet software CD, Macintosh partition on page 170](#).

The root directory in the Windows partition of the software CD contains the AUTORUN.EXE file, the SETUP.EXE file, and the following directories and support files:

- Autorun
- Driver Deployment Utility
- Drivers
- Fonts
- HPSU
- Manuals

- PortMonitor
- Temp

The printing-system files for each language reside in the following directories:

- Drivers

CD versions and language support

The HP Color LaserJet Enterprise CP4020-CP4520 Series printing-system software CD is available with the following components and languages.

Table 1-3 Software CD supported languages

Language	Two-letter abbreviation	HP-preferred name	File designation
Arabic	AR	Arabic	ARWW
Bulgarian	BG	Bulgarian	BGWW
Catalan	CA	Catalan	CAWW
Croatian	HR	Hrvatski	HRWW
Czech	CS	Cestina	CSWW
Danish	DA	Dansk	DAWW
Dutch	NL	Nederlands	NLWW
English	EN	English	ENWW
Estonian	et	Eesti	ETWW
Finnish	FI	Suomi	FIWW
French	FR	Francais	FRWW
German	DE	Deutsch	DEWW
Greek	EL	Greek	ELWW
Hebrew	HE	Hebrew	HEWW
Hungarian	HU	Magyar	HUWW
Italian	IT	Italiano	ITWW
Japanese	JA	Japanese	JAWW
Korean	KO	Korean	KOWW
Latvian	LV	Latviski	LVWW
Lithuanian	LT	Lietuviskai	LTWW
Norwegian	NO	Norsk	NOWW
Polish	PL	Polski	PLWW
Portuguese	PT	Portugues	PTWW
Romanian	RO	Romanian	ROWW
Russian	RU	Russian	RUWW
Serbian	SR	Srpski	SRWW

Table 1-3 Software CD supported languages (continued)

Language	Two-letter abbreviation	HP-preferred name	File designation
Simplified Chinese	ZHCN	Simplified Chinese	ZHCN
Slovak	SK	Slovak	SKWW
Slovenian	SL	Slovenian	SLWW
Spanish	ES	Espanol	ESWW
Swedish	SV	Svenska	SVWW
Thai	TH	Thai	THWW
Traditional Chinese	ZHTW	Traditional Chinese	ZHTW
Turkish	TU	Turkce	TUWW
Ukrainian	UK	Ukrainian	UKWW

Driver languages

The HP Color LaserJet Enterprise CP4020-CP4520 Series product provides driver support in the following languages.

Table 1-4 Supported printer driver languages

Component	Language list
HP PCL 6 Print Driver	<ul style="list-style-type: none"> • Arabic • Lithuanian
HP PCL 5 Universal Print Driver	<ul style="list-style-type: none"> • Bulgarian • Latvian
HP PS Universal Print Driver	<ul style="list-style-type: none"> • Catalan • Dutch • Czech • Norwegian • Danish • Polish • German • Portuguese • Greek • Romanian • English • Russian • Spanish • Slovak • Estonian • Slovenian • Finnish • Serbian • French • Swedish • Hebrew • Thai • Croatian • Turkish • Hungarian • Ukrainian • Italian • Simplified Chinese • Japanese • Traditional Chinese • Korean

Installer languages

The HP Color LaserJet Enterprise CP4020-CP4520 Series product provides installer component support in the following languages.

Table 1-5 Installer component languages

Component	Language list
Administrator install	<ul style="list-style-type: none">• Arabic• Lithuanian
CD Browser	<ul style="list-style-type: none">• Bulgarian• Latvian
Common Windows Installer	<ul style="list-style-type: none">• Catalan• Dutch
Web Registration (with the following exceptions)	<ul style="list-style-type: none">• Czech• Norwegian
<ul style="list-style-type: none">• Arabic and Hebrew support in English only• Catalan support in Spanish only• No support for Bulgarian, Estonian, Croatian, Lithuanian, Latvian, Romanian, Slovak, Slovenian, Serbian, Thai, Ukrainian	<ul style="list-style-type: none">• Danish• Polish• Portuguese• Romanian• Russian• Slovak• Slovenian• Serbian• Swedish• Thai• Turkish• Ukrainian• Simplified Chinese• Traditional Chinese
	<ul style="list-style-type: none">• German• Greek• English• Spanish• Estonian• Finnish• French• Hebrew• Croatian• Hungarian• Italian• Japanese• Korean

Documentation languages

The HP Color LaserJet Enterprise CP4020-CP4520 Series product provides documentation in the following languages.

Table 1-6 Documentation languages

Component	Language list
<ul style="list-style-type: none"> • <i>HP Color LaserJet Enterprise CP4020-CP4520 Series User Guide (.PDF file)</i> 	<ul style="list-style-type: none"> • Arabic • Bulgarian
	<ul style="list-style-type: none"> • Lithuanian • Latvian
<ul style="list-style-type: none"> • <i>HP Color LaserJet Enterprise CP4020-CP4520 Series User Guide (.CHM file)</i> 	<ul style="list-style-type: none"> • Catalan • Czech
	<ul style="list-style-type: none"> • Dutch • Norwegian
<ul style="list-style-type: none"> • <i>HP Color LaserJet Enterprise CP4020-CP4520 Series Driver Preconfiguration User Guide (Available in English only)</i> 	<ul style="list-style-type: none"> • Danish • German • Greek
	<ul style="list-style-type: none"> • Polish • Portuguese • Romanian
	<ul style="list-style-type: none"> • Russian • Slovak
<ul style="list-style-type: none"> • <i>HP JetDirect Administrator's Guide (.PDF file) (with the following exceptions)</i> <ul style="list-style-type: none"> ◦ Catalan documentation in Spanish only ◦ No documentation in Arabic, Bulgarian, Czech, Greek, Hebrew, Croatian, Estonian, Lithuanian, Latvian, Romanian, Slovak, Slovenian, Serbian, Turkish, Ukrainian 	<ul style="list-style-type: none"> • English • Spanish • Estonian • Finnish • French • Hebrew • Croatian • Hungarian
	<ul style="list-style-type: none"> • Slovenian • Serbian • Swedish • Thai • Turkish • Ukrainian
	<ul style="list-style-type: none"> • Italian • Japanese • Korean
	<ul style="list-style-type: none"> • Simplified Chinese • Traditional Chinese

Product views

Front view

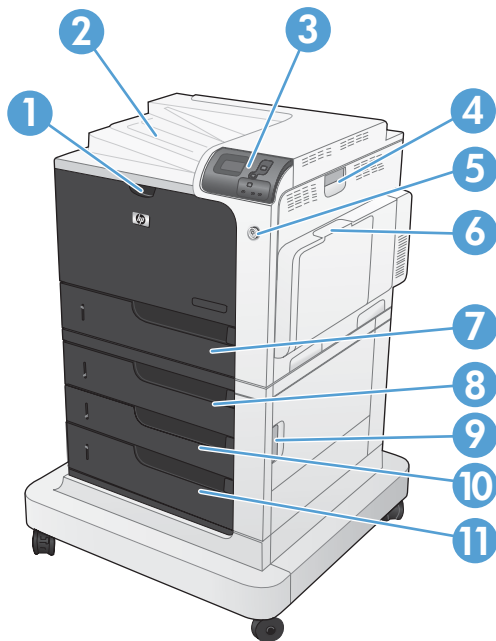

1	Front door (access to print cartridges and toner collection unit)
2	Standard output bin
3	Control panel
4	Right door (access for clearing jams)
5	On/off button (illuminates when turned on)
6	Tray 1 (pull the handle to open the tray)
7	Tray 2
8	Optional Tray 3 (included with the HP Color LaserJet CP4525xh model)
9	Lower right door (access for clearing jams)
10	Optional Tray 4 (included with the HP Color LaserJet CP4525xh model)
11	Optional Tray 5 (included with the HP Color LaserJet CP4525xh model)

Back view

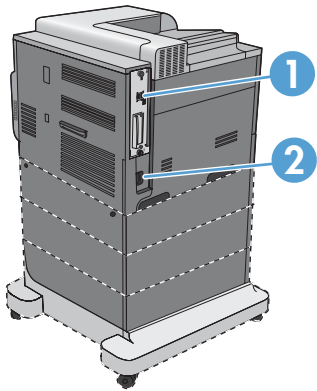

1	Interface ports
2	Power connection

Interface ports

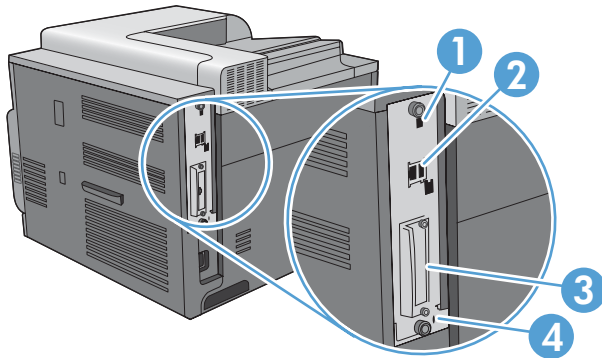

1	Hi-speed USB 2.0 printing port
2	Local area network (LAN) Ethernet (RJ-45) network port
3	EIO interface expansion slot
4	Slot for a cable-type security lock

Serial number and model number location

The model number and serial number are listed on an identification label located on the back of the product and on the inside of the toner access door on the front of the product. The serial number contains information about the country/region of origin, the product version, production code, and the production number of the product.

Model name	Model number
HP Color LaserJet CP4025n	CC489A
HP Color LaserJet CP4025dn	CC490A
HP Color LaserJet CP4525n	CC493A
HP Color LaserJet CP4525dn	CC494A
HP Color LaserJet CP4525xh	CC495A

2 Windows software description

Introduction

The HP Color LaserJet Enterprise CP4020-CP4520 Series product comes with software and installers for Microsoft Windows and Apple Computer, Inc., Macintosh systems. Linux and UNIX systems are supported, and software is available on the Web. For information about specific system installers, drivers, and components, see the section that corresponds to that system. For information about Mac software, see [Macintosh software and utilities on page 167](#).

This section contains information about the following topics:

- [Windows printing-system software](#)
- [Driver configuration for Windows](#)
- [HP Driver Diagnostic Printer Check Tool](#)
- [Advanced color use](#)
- [HP Easy Printer Care](#)
- [HP Embedded Web Server](#)
- [HP Web Jetadmin](#)
- [Font support](#)
- [HP Driver Deployment Utility](#)

Windows printing-system software

This section contains information about the following topics:

- [Printing system and installer](#)
- [HP Color LaserJet print drivers](#)

Printing system and installer

The following sections contain information about the printing-system software and the installer on the software CD that came with the product.

HP Color LaserJet Enterprise CP4020-CP4520 Series printing-system software CD for Windows systems

For the Microsoft Windows environment (Windows XP, Windows Server 2003, Windows Server 2008, Windows Vista, and Windows 7), the HP Color LaserJet Enterprise CP4020-CP4520 Series printing-system software CD provides an interactive CD browser that you can use to install the print drivers and related components, and to gain access to online user documentation and optional HP software.

The following figure shows the main screen of the HP Color LaserJet Enterprise CP4020-CP4520 Series printing-system software CD (part of the interactive CD browser), which appears when you insert the printing-system software CD in a CD-ROM drive. If the screen does not appear when you insert the software CD, follow these steps to open the CD browser:

1. In Windows Vista, click the **Start** button, click **All Programs**, and then click **Accessories**.
For all other Windows operating systems, click **Start**.
2. Click **Run**.

3. Click **Browse....** and navigate to the root directory of the software CD.
4. Double-click the SETUP.EXE file to start the installer.

Figure 2-1 Installation software CD browser



The main screen of the software CD contains installation and documentation options in the left panel. As you move the cursor over each option, a description of the option appears under the product banner.

The following options are available on the main screen of the printing-system software CD.

- **Install Now.** The HP Driver Installation Utility (HPDIU) guides you through the HP Color LaserJet Enterprise CP4020-CP4520 Series printing-system software installation. When you click **Install Now**, only the HP PCL 6 driver, screen fonts, and user guide are installed.
- **Advanced Install Options.** Provides you with the flexibility to select the drivers and software components to install. The following options are available when you click this option:
 - **Install PCL 6 Driver**
 - Install PCL 5 Driver
 - **Install PS Driver**
 - **Install Documentation and Optional Software**
 - **Administrator Documentation.** Use this option to view the HP Color LaserJet Enterprise CP4020-CP4520 Series administrator documentation. The following document options are available:
 - HP Jetdirect Guide**

Color Printing Access and Usage

HP Driver Preconfiguration User Guide

- **Administrator software.** Click this option to see a list of administrator software available for the HP Color LaserJet Enterprise CP4020-CP4520 Series product. The following options are available:

HP Universal Print Driver. Clicking this link redirects the browser to the HP Web site that provides more information about the HP Universal Print Driver and downloadable software.

Driver Deployment Utility. Click this option to allow an administrator to create a driver install package for silent, unattended installation by end users.

HP Web Jetadmin. Click this option to download HP Web Jetadmin software from the Web for a Web browser-based network-management tool designed for network administrators.

- **User Documentation.** Use this option to view the HP Color LaserJet Enterprise CP4020-CP4520 Series user documentation. The following document options are available:
 - **User Guide (CD)**
 - **User Guide (Web)**
 - **Install Notes**
 - **Show Me How**
- **Support.** To increase productivity and get the most use from your HP Color LaserJet Enterprise CP4020-CP4520 Series product, the following links are available for these HP Web sites:
 - **Product Registration.** Register your product online, and then gain access to support and services, manage your profile, and sign up for free support alerts, driver notices, and personalized newsletters.
 - **Supplies.** Contains information about ordering HP Color LaserJet Enterprise CP4020-CP4520 Series product supplies.
 - **Product Information.** Contains support information and updates.
 - **hp.com.** Contains information about products and services, support, drivers, and HP online stores.

Installer features

The common installer is designed to provide a simple and consistent installation method for the product. The common installer is available for the Windows XP, Windows Server 2003, Windows Server 2008, Windows Vista, and Windows 7 operating systems and offers the following features:

- The HP Color LaserJet Enterprise CP4020-CP4520 Series printing-system software CD features an interactive software interface. See [HP Color LaserJet Enterprise CP4020-CP4520 Series printing-system software CD for Windows systems on page 22](#).
- The network connection is integrated so that you can install drivers and connect to a networked product in a single process.

- After installation, the installer allows you to add additional drivers, documentation, and fonts.
- The **Additional Options** at the end of the installation process provides the opportunity to install HP Update and marketing resources software, check online for product-specific merchandise, as well as allow users to register their product using Web Registration.

All of the Windows system components are installed by using the HP Color LaserJet Enterprise CP4020-CP4520 Series printing-system installer. The installer automatically detects the language of choice and the operating system. You can select the type of installation that you prefer: **Install Now** (recommended installation) or **Advanced Install Options** (customized installation).

HP Color LaserJet print drivers

HP Color LaserJet Enterprise CP4020-CP4520 Series print drivers provide the printing features and communication between the computer and the product. The software CD includes software for end users and network administrators who are working in the following operating environments:

- Windows XP (32-bit and 64-bit), Windows Server 2003 (32-bit and 64-bit), Windows Server 2008 (32-bit and 64-bit), and Windows Vista (32-bit and 64-bit), and Windows 7 (32-bit and 64-bit)
- Apple Mac OS X v10.4 and later

In Windows operating systems, automatic configuration, driver updates after a new product configuration, and preconfiguration features are available with the HP Color LaserJet Enterprise CP4020-CP4520 Series product.

 **NOTE:** For additional information about installing the printing-system software, see the *HP Color LaserJet Enterprise CP4020-CP4520 Series Install Notes* on the printing-system software CD.

All of the drivers provide access to the paper-handling and print-quality features.

HP PCL 6 Print Driver, PCL 5 Universal Print Driver, and PS Universal Print Driver

All of the Windows drivers are supported by Microsoft 32-bit and 64-bit operating systems. The HP PCL 6 driver is included on the HP Color LaserJet Enterprise CP4020-CP4520 Series printing-system software CD. The PCL 5 Universal Print Driver and the PS Universal Print Driver are available for download at the following Web sites:

www.hp.com/go/cljcp4025_software or www.hp.com/go/cljcp4525_software

 **NOTE:** If you select the recommended installation by clicking **Install Now** on the main screen of the CD browser, the HP PCL 6 Print Driver is installed by default.

Print-driver version numbers for Windows operating systems

Access to print-driver version numbers varies, depending on the operating system in which the HP Color LaserJet Enterprise CP4020-CP4520 Series product is installed.

 **NOTE:** For a list of HP Color LaserJet Enterprise CP4020-CP4520 Series print drivers, updated HP printing-system software, and product-support information, go to:

www.hp.com/go/cljcp4025_software or www.hp.com/go/cljcp4525_software

The Windows XP, Windows Server 2003, Windows Server 2008, Windows Vista, and Windows 7 operating systems support the HP PCL 6, PCL 5 Universal Print Driver, and PS Emulation Universal

Print Drivers. If you are using an HP print driver in a Windows environment, follow these steps to find driver-version information:

1. In Windows Vista and Windows 7, click the **Start** button, click **Control Panel**, click **Hardware and Sound**, and then click **Printers**.

In Windows XP, Windows Server 2003, and Windows Server 2008, click **Start**, click **Settings**, and then click **Printers and Faxes**.

2. Right-click the product icon.
3. Click **Properties**.
4. Click the **About** tab.

You can also gain information about driver versions by clicking the **About** button that appears on most driver tabs.

Driver configuration for Windows

The HP print drivers feature bidirectional communication technology which, in supported environments, provide automatic discovery and driver configuration for product accessories at the time of installation.

Some accessories that are automatically discovered and configured include the duplexing unit, optional paper trays, printer hard disk, and dual inline memory modules (DIMMs).

Driver autoconfiguration

Automatic discovery and driver configuration through bidirectional communication occurs in the following circumstances:

- When a print driver is installed by using the installer
- When using the Update Now feature for a driver that is already installed

However, as shown in the following table, driver autoconfiguration and Update Now are *not* available in Windows XP, Windows Server 2003, Windows Server 2008, Windows Vista, or Windows 7 operating systems over a direct connection when the HP Color LaserJet Enterprise CP4020-CP4520 Series product is installed by using the Add Printer wizard.

Table 2-1 Automatic discovery and driver configuration through bidirectional communication¹

Connection type	Add Printer Wizard install	Common installer
Network	Yes	Yes
Direct connection	No	Yes

¹ The table applies to Windows XP, Windows Server 2003, Windows Server 2008, Windows Vista, and Windows 7.

Bidirectional communication

In environments that support bidirectional communication, the computer communicates with the product during installation, determines the physical configuration, and then configures the driver accordingly.

Bidirectional communication is the capability of the product to respond to data inquiries from the computer and report information back, such as what type of print paper is available or what accessories are connected to the product. Bidirectional communication depends on the network operating system and on the type of connection that exists between the computer and the HP Color LaserJet Enterprise CP4020-CP4520 Series. If the connection does not have this capability (that is, if it has no bidirectional mode), it can only accept commands from the host and cannot report information back to the host computer.

Enterprise AutoConfiguration

Enterprise AutoConfiguration (EAC) uses bidirectional communication to provide autoconfiguration functionality for installation of the print driver over a network, whether you use the installer on the printing-system software CD or the Add Printer wizard to install the driver. Driver installation that includes EAC is configured with the same settings as the physical configuration of the product. Configuration occurs without user interaction.

If bidirectional-communication software has been installed previously, EAC is not activated, and the pre-existing bidirectional-communication software is used to configure the print driver.

If bidirectional communication software has not been installed, EAC installs bidirectional-communication software that allows it to communicate with the product and automatically match the print driver with the actual product configuration. EAC is activated during installation of the driver or whenever the Update Now feature is used.

If the HP Color LaserJet Enterprise CP4020-CP4520 Series product configuration changes after installation, the driver can be automatically updated with the new configuration in environments that support bidirectional communication by using the Update Now feature. For more information, see [Update Now on page 29](#).

The following tables show the availability of EAC for various operating systems and network environments that support bidirectional communication.

Table 2-2 EAC availability in Microsoft Windows and Microsoft Share

Method	Connection type		Microsoft Share ¹			
			2000	XP	2000/XP host with 2000/XP client/ Windows Server 2008/ Windows Vista	
		USB				
	Network	Jetdirect	TCP/IP	x	x	x
			IPX/SPX	x	x	x
	Standard		TCP/IP (HP)	x	x	x
			TCP/IP (MS)	x	x	x
			IPX/SPX (HP)	x	x	x
Add Printer	Direct connect	Parallel				
		USB				
	Network	Jetdirect	TCP/IP	x	x	x
			IPX/SPX	x	x	x
		Standard	TCP/IP (HP)	x	x	x
			TCP/IP (MS)	x	x	x
			IPX/SPX (HP)	x	x	x

¹ This column represents the following Microsoft Share configurations: Windows 2000, Windows XP, Windows Server 2003, Windows Server 2008, or Windows Vista host with Windows 2000, Windows XP, Windows Server 2003, Windows Server 2008, or Windows Vista client.

Table 2-3 EAC availability in Novell Netware environments

Method	Connection type		Novell		
			Netware 4.x		Netware 5.x
			Bindery queue	NDS queue	Bindery queue
	USB				
Network	Jetdirect	TCP/IP	x	x	x
		IPX/SPX			
	Standard	TCP/IP (HP)			
		TCP/IP (MS ¹)			
		IPX/SPX (HP)			

¹ Bidirectional functionality is supported only with the client software from Novell. It is not supported with Microsoft Client Service for NetWare.

Update Now

If you have modified the configuration of the HP Color LaserJet Enterprise CP4020-CP4520 Series product since installation, the driver can be automatically updated with the new configuration in environments that support bidirectional communication. Use the Update Now feature to automatically reflect the new configuration in the driver.

For example, if the product is installed and an optional paper-handling accessory is added later, use the Update Now feature to query the product and update the settings to match the new product configuration.

The feature automatically updates the registry and changes the configuration information that appears on the **Device Settings** tab.

 **NOTE:** Depending on which settings were updated, the Update Now feature might change the configuration information that displays on the print-driver tabs, instead of (or in addition to) changing the information on the **Device Settings** tab.

NOTE: The Update Now feature is not supported in environments where shared Windows XP clients are connected to Windows XP hosts.

To activate the Update Now feature, follow these steps:

1. In Windows Vista and Windows 7, click the **Start** button, click **Control Panel**, click **Hardware and Sound**, and then click **Printers**.
In Windows XP, Windows Server 2003, and Windows Server 2008, click **Start**, click **Settings**, and then click **Printers and Faxes**.
2. Right-click the product name.
3. Click **Properties**.
4. Click **Device Settings**.
5. If necessary, click **Installable Options** to expand it and show the options.

6. In the **Automatic Configuration** drop-down menu, select **Update Now**.
7. Click **OK** to save the setting.

HP Driver Configuration

HP Driver Configuration is a software architecture and set of tools that permits HP printing-system software to be customized and distributed in managed corporate printing environments. Using HP Driver Configuration, information technology (IT) administrators in corporate and enterprise environments can preconfigure the printing and device defaults for HP print drivers before installing the drivers in the network environment.

HP Driver Configuration is most beneficial when configuring print drivers for multiple workstations or print servers for print queues that share the same configuration. Two types of features can be configured:

- device settings
- printing-preferences settings

The driver is configured to match the product hardware so that access to all of the product accessories through the driver is enabled correctly (for example, for duplexing units and additional input trays). Most driver-feature settings can also be configured.

HP Driver Configuration configures the driver to match the accessories that are installed on the product, or to match the settings that IT administrators make in the configuration (.CFG) file (for example, optional trays, total amount of memory, job-storage settings, or mopier settings).

The configuration process consists of three basic steps:

- driver acquisition
- driver configuration
- driver installation and deployment

These steps can be accomplished in different ways, depending on the tool that is being used to define the configuration.

The driver configuration process is supported through three distinct tools. All three are designed with the same basic user-interface (UI) controls for interacting with the .CFG file, but are packaged differently, either to support established product installation workflows or to leave the deployment and installation of the driver entirely up to the user. The following tools support driver preconfiguration:

- **HP Driver Configuration Utility.** The HP Driver Configuration Utility is a small, standalone, Windows-software program that the administrator can use to open the .CFG file that is associated with a particular driver and make modifications that are applied when that driver is installed on the target computer. It is intended for use in environments that have an established process for deploying drivers. This is the preconfiguration tool of choice to support any Novell or HP Print Server Appliance (PSA) and Point and Print environments. It is used in the way that any ordinary Windows software program is used.

The HP Driver Configuration Utility is available at the following Web site:

www.hp.com/go/dcu

- **The HP Web Jetadmin Driver Configuration Plugin.** The HP Web Jetadmin provides a queue-creation program that can be used to create printer queues on Windows 2000, Windows XP, Windows Server 2003, or Windows Server 2008. The HP Web Jetadmin Driver Configuration

Plugin adds a number of screens to the existing queue-creation workflow from which the drivers that are being installed for the queues can be customized as part of the process. The plug-in is limited to Internet Explorer browsers. Netscape Navigator is not supported.

HP Web Jetadmin v10.0 is supported by the following:

- Windows XP (Professional only)
- Windows Server 2003 (R2 only)
- Windows Server 2008
- Windows Vista (Business and Enterprise Editions)

The HP Web Jetadmin print management features are supported by the following:

- Windows XP Professional (with Service Pack 2 or higher)
- Windows Server 2003
- **HP Driver Deployment Utility.** The HP Driver Deployment Utility (HP DDU) was created to simplify the deployment of print drivers onto a client computer. It is a simple utility that packages the print-driver files, and the code needed to deploy them, into two files: an .EXE file and a .CAB file. These files are run on the client computer to copy the print-driver files to the Windows driver store and, for network packages, to install the product. This utility is supported on Windows XP, Windows Server 2003, Windows Server 2008, and Windows Vista operating systems.

To gain access to the HP DDU, insert the software CD into the CD-ROM drive, and then navigate to the Driver Deployment Utility folder.

For more information about the HP DDU, refer to [HP Driver Deployment Utility on page 43](#)

For detailed information about gaining access to and installing these tools, see the **HP Driver Configuration Support Guide** at the following Web site and click on the **Manuals** link.

www.hp.com/go/dcu

Lockable features

The following driver features can be locked to prevent end-users from changing settings:

- **Print on Both Sides** (duplex). The options are **True** or **False**.
- **Print in Grayscale.** The options are **Disable** or **Enabled**.
- **Media Type.** The options include all the paper types that the HP Color LaserJet Enterprise CP4020-CP4520 Series product supports.
- **Paper Source.** The options are **Printer Auto Select, Manual Feed (Tray 1), Tray 1, Tray 2. Tray 3** is standard on the HP Color LaserJet CP4525xh product model, and an option on the other HP Color LaserJet Enterprise CP4020-CP4520 Series models.
- **Job retention mode.** The option is **Off**.
- Orientation
- Color Options

When a feature is locked, the selected default option is the only option that is available to users. Generally, the feature is unavailable in the driver UI after it has been locked.

Continuous export

The term "continuous export" refers to the ability of the print driver to copy the latest print-driver settings back to the working copy of the preconfiguration file. Using this feature, the exported values can be transferred when a compatible version of the print driver is used to upgrade the print driver. For instance, if the orientation is set to **Landscape** for a driver originally installed in Windows XP, then the orientation setting automatically remains **Landscape** when the operating system is upgraded to Windows Vista, Windows Server 2003, or Windows Server 2008. The continuous export feature functions transparently from the user's perspective and works only between print drivers of identical product models.

 **NOTE:** Not all of the driver parameters can be exported; however, the exportable components are always the same as the components that can be preconfigured.

The following table shows drivers and operating systems that support HP Driver Configuration.

Table 2-4 Operating systems that support HP Driver Preconfiguration

Driver	Windows X P	Windows Server 2003	Windows Server 2008	Windows Vista	Windows 7	Mac OS X v10.4 and later	Linux
HP PCL 6 Print Driver	Yes	Yes	Yes	Yes	Yes	NA	NA
HP PCL 5 Universal Print Driver	Yes	Yes	Yes	Yes	Yes	NA	NA
HP PS Universal Print Driver	Yes	Yes	Yes	Yes	Yes	NA	NA

¹ NA: Not applicable; the driver is not supported in this operating system.

HP Driver Diagnostic Printer Check Tool

The HP Driver Diagnostic Printer Check Tool is a Web-based diagnostic software that you can use to determine whether you are using the correct and most current Windows print driver for the HP Color LaserJet Enterprise CP4020-CP4520 Series product. Two methods are available to gain access to the HP Driver Diagnostic Printer Check Tool:

1. Open an Internet browser.
2. Go to the following Web site:

www.hp.com/go/drivercheck

Or, use this alternative method.

1. Open an Internet browser.
2. Go to the HP Business Support Center (BSC) at the following Web site:

www.hp.com/go/bsc

3. Click the **self-help resources** link on the left navigation bar.
4. Click **automatic driver checker** to run the HP Driver Diagnostic Printer Check Tool.

When the HP Driver Diagnostic Printer Check Tool runs, the products that are currently installed on the computer appear in a list. When you select the HP product that you would like to check, the HP Driver Diagnostic Printer Check Tool gathers information about your product, drivers, and system setup in order to diagnose the software driver configuration and check the print driver. The tool then verifies whether you are using the latest driver, informs you if you are using an incorrect driver for the HP product, and lets you know if an updated driver version is available for the product. If an updated driver is available, you can download and install the latest driver version by clicking it.

The data that the HP Driver Diagnostic Printer Check Tool gathers is stored anonymously so that HP can analyze and continuously improve its diagnostic tools. No private data is gathered from the computer.

Advanced color use

Color Access Control

The HP Color LaserJet Enterprise CP4020-CP4520 Series has the ability to monitor and control color print-job use. For more information about color access control, go to the following Web site and look under **Learn More**.

www.hp.com/go/cac

The following table shows various tools that can be used to control color-printing access.

Table 2-5 Color access control tools

Tool	Description
HP Embedded Web Server	<p>The HP Embedded Web Server (HP EWS) is a Web-browser-based utility that provides an interface to the product that you can use to change product settings, including color access control settings. No special software needs to be installed or configured. It allows you to set color printing restrictions and view a log of color printing use. The HP EWS is designed for one-to-one product configuration monitoring and management.</p> <p>For more information, see HP Embedded Web Server on page 35.</p>
HP Web Jetadmin	<p>The HP Web Jetadmin provides an interface to the product through a Web browser on single network-administration servers. Use HP Web Jetadmin to manage HP Jetdirect-connected products within an intranet.</p> <p>For more information, see the following Web site:</p> <p>www.hp.com/go/webjetadmin</p>
Color usage job log	<p>The color usage job log shows color and monochrome print job statistics for a product.</p>
Product control panel	<p>Use the product control panel to restrict color use in network-connected products.</p> <p>For more information, see the following procedure.</p>

To restrict color-printing access to a network-connected HP Color LaserJet Enterprise CP4020-CP4520 Series from the product control panel, follow these steps:

1. Press the **Home** button  to open the menus.
2. Press the **up arrow** ▲ or the **down arrow** ▼ to scroll to **MANAGE SUPPLIES**, and then press **OK**.
3. Press the **up arrow** ▲ or the **down arrow** ▼ to scroll to **RESTRICT COLOR USE**, and then press **OK**.
4. Press the **up arrow** ▲ or the **down arrow** ▼ to scroll to one of the following options, and then click **OK**:
 - **ENABLE COLOR**. This is the default setting. Use of color-printing features is unrestricted.
 - **COLOR IF ALLOWED**. Network administrators can use this setting to allow color-printing to certain users and restrict it for other users. User privileges can be set using HP EWS. For more information, see the EWS online help.
 - **DISABLE COLOR**. This setting denies the use of color-printing features to all users.

International Color Consortium profiles

HP provides cyan-magenta-yellow-black (CMYK) (HPCP4025C.ICC or HPCP4525C.ICC) and standard red-green-blue (sRGB) (HPCP4025R.ICC or HPCP4525R.ICC) International Color Consortium (ICC) custom profiles with the HP Color LaserJet Enterprise CP4020-CP4520 Series product. The CMYK profile can only be used with a postscript driver; the sRGB profile can be used with any of the HP Color LaserJet Enterprise CP4020-CP4520 Series print drivers. The profiles are available at the following HP Web site:

www.hp.com/go/cljcp4025_software or www.hp.com/go/cljcp4525_software

The ICC profiles describe the way color is interpreted in the default CMYK and RGB modes. These profiles can be used for color conversions in a color-managed workflow. The sRGB profile matches the default RGB mode (sRGB), which is enabled with the **Default (sRGB)** color setting in either a PCL or postscript driver. The product interprets CMYK data according to the Specifications for Web Offset Publications (SWOP) simulation when **Default CMYK+** is the selected **CMYK Color** setting in the postscript driver, and a more accurate SWOP rendering can be produced by selecting the **SWOP** setting. This standard defines how a particular set of CMYK ink colors should behave. Emulation for Dainippon Press (DIC) and Euro-standard CMYK inks used in Asia and Europe are also available and can be selected from the print driver.

PANTONE color profiles

Most software programs that support the use of PANTONE colors for graphic objects include the PANTONE name in the postscript output along with the color values that are assigned to the object. Select a software program that uses a PANTONE palette in a CMYK workspace, and print with the HP PS Universal Print Driver in Windows XP, Windows Server 2003, Windows Server 2008, Windows Vista, or Windows 7.

When **SWOP** is selected as the **CMYK Color** setting, these CMYK values provide a good reproduction of the PANTONE 4C spot-color simulations.

Vector graphics, such as company logos that are created in PANTONE Application Palettes, can be imported into Microsoft Word, PowerPoint, or other Microsoft Office software programs. The color program must create an encapsulated postscript (.eps) file of the image that will be imported. Use the **Insert file** function to import the file into the Office document.

 **NOTE:** Cutting and pasting from the clipboard does not work. These tasks do not preserve the PANTONE name or the CMYK palette value.

HP Easy Printer Care

HP Easy Printer Care is a standalone software program that manages multiple products. As of the publication of this document, the HP Easy Printer Care product is not supported with the HP Color LaserJet CP4025 and HP Color LaserJet CP4525 Series printers.

HP Embedded Web Server

The product is equipped with an embedded Web server, which provides access to information about product and network activities. This information appears in a Web browser, such as Microsoft Internet Explorer, Netscape Navigator, Apple Safari, or Firefox.

The embedded Web server resides on the product. It is not loaded on a network server.

The embedded Web server provides an interface to the product that anyone who has a network-connected computer and a standard Web browser can use. No special software is installed or configured, but you must have a supported Web browser on the computer.

Certain pages in the HP Embedded Web Server include online help.

To open the HP EWS, complete the following steps:

1. At a network-connected computer, open a Web browser.
2. In the browser address field, type the product IP address, and then press the **Enter** button.

If you do not know the product IP address, print a configuration page, which lists the IP address in the IPv4 section.

- a. Press the **Home** button  to open the menus.
 - b. Press the **up arrow** ▲ or the **down arrow** ▼ to scroll to **INFORMATION**, and then press **OK**.
 - c. Press the **up arrow** ▲ or the **down arrow** ▼ to scroll to **PRINT CONFIGURATION**.
 - d. Press the **OK** button to print the configuration page.
3. To open the HP EWS online help, click the **Help** link in the upper righthand corner of the page.

Not all HP EWS pages are equipped with help.

HP Web Jetadmin

Use HP Web Jetadmin and a Web browser to manage HP Jetdirect-connected products within an intranet. HP Web Jetadmin is a Web-based management tool and should be installed only on a single network-administration server.

To download a current version of HP Web Jetadmin and for the latest list of supported host systems, go to the following Web site:

www.hp.com/go/webjetadmin

Font support

The basic fonts listed here are included with Microsoft Windows software. The additional PS fonts are available on the CD that came with the product.

Basic fonts

Microsoft Windows software includes these basic fonts, which can be used with any HP printing product:

- Arial
- Courier New Italic
- Times New Roman Italic
- Arial Italic
- Courier New Bold
- Times New Roman Bold
- Arial Bold
- Courier New Bold Italic
- Times New Roman Bold Italic
- Arial Bold Italic
- Symbol
- Wingdings
- Courier New
- Times New Roman

Default fonts

The following default fonts are installed through a Full Installation of the HP Color LaserJet Enterprise CP4020-CP4520 Series printing-system software.

Table 2-6 Default fonts

Font name	Font style	File name
Albertus Extra Bold	Regular	ALBR85W.TTF
Albertus Medium	Regular	ALBR55W.TTF
Antique Olive	Regular	OLVR55W.TTF
Antique Olive	Bold	OLVR75W.TTF
Antique Olive	Italic	OLVR56W.TTF
CG Omega	Regular	CGOR45W.TTF
CG Omega	Bold	CGOR65W.TTF
CG Omega	Bold Italic	CGOR66W.TTF

Table 2-6 Default fonts (continued)

Font name	Font style	File name
CG Omega	Italic	CGOR46W.TTF
CG Times	Regular	CGTR45W.TTF
CG Times	Bold	CGTR65W.TTF
CG Times	Bold Italic	CGTR66W.TTF
CG Times	Italic	CGTR46W.TTF
Clarendon Condensed	Bold	CLAR67W.TTF
Coronet	Regular	CORONET.TTF
CourierPS	Regular	CPSR45W.TTF
CourierPS	Bold	CPSR65W.TTF
CourierPS	Bold Oblique	CPSR66W.TTF
CourierPS	Oblique	CPSR46W.TTF
Garamond	Antiqua	GARR45W.TTF
Garamond	Halbfett	GARR65W.TTF
Garamond	Kursiv	GARR46W.TTF
Garamond	Kursiv Halbfett	GARR66W.TTF
Helvetica	Regular	HELR45W.TTF
Helvetica	Bold	HELR65W.TTF
Helvetica	Bold Oblique	HELR66W.TTF
Helvetica Narrow	Regular	HELR47W.TTF
Helvetica Narrow	Bold	HELR67W.TTF
Helvetica Narrow	Bold Oblique	HELR68W.TTF
Helvetica Narrow	Oblique	HELR48W.TTF
Helvetica	Oblique	HELR46W.TTF
ITC Avant Garde Gothic	Book	AVGR45W.TTF
ITC Avant Garde Gothic	Book Oblique	AVGR46W.TTF
ITC Avant Garde Gothic Demi	Regular	AVGR65W.TTF
ITC Avant Garde Gothic Demi	Oblique	AVGR66W.TTF
ITC Bookman Light	Regular	BOKR35W.TTF
ITC Bookman Light	Italic	BOKR36W.TTF
ITC Bookman Demi	Regular	BOKR75W.TTF
ITC Bookman Demi	Italic	BOKR76W.TTF
ITC Zapf Chancery	Medium Italic	CHANC___.TTF
ITC Zapf Dingbats	Regular	DINGS___.TTF
Letter Gothic	Regular	LETR45W.TTF

Table 2-6 Default fonts (continued)

Font name	Font style	File name
Letter Gothic	Bold	LETR65W.TTF
Letter Gothic	Italic	LETR46W.TTF
Marigold	Regular	MARIGOLD.TTF
New Century Schoolbook	Bold	NCSR75W.TTF
New Century Schoolbook	Bold Italic	NCSR76W.TTF
New Century Schoolbook	Italic	NCSR56W.TTF
New Century Schoolbook	Roman	NCSR55W.TTF
Palatino	Bold	PALR65W.TTF
Palatino	Bold Italic	PALR66W.TTF
Palatino	Italic	PALR46W.TTF
Palatino	Roman	PALR45W.TTF
SymbolPS	Regular	SYMP5___.TTF
Times*	Bold	TIMR65W.TTF
Times	Bold Italic	TIMR66W.TTF
Times	Italic	TIMR46W.TTF
Times	Roman	TIMR45W.TTF
Univers	Bold	UNVR65W.TTF
Univers	Bold Italic	UNVR66W.TTF
Univers Condensed	Bold	UNVR67W.TTF
Univers Condensed	Bold Italic	UNVR68W.TTF
Univers Condensed	Medium	UNVR57W.TTF
Univers Condensed	Medium Italic	UNVR58W.TTF
Univers	Medium	UNVR55W.TTF
Univers	Medium Italic	UNVR56W.TTF

Ninety-two additional PS emulation fonts are also available on the CD.

Table 2-7 Additional PS emulation fonts

Font name	Font style	File name
Albertus MT	Regular	PS_12639.TTF
Albertus MT	Italic	PS_12640.TTF
Albertus MT Lt	Regular	PS_14530.TTF
Antique Olive CompactPS	Regular	PS_11120.TTF
Antique Olive Roman	Regular	PS_11119.TTF
Antique Olive Roman	Bold	PS_11118.TTF

Table 2-7 Additional PS emulation fonts (continued)

Font name	Font style	File name
Antique Olive Roman	Italic	PS_11846.TTF
Apple Chancery	Italic	PS_24516.TTF
Bodoni Poster	Regular	PS_12704.TTF
Bodoni PosterCompressed	Regular	PS_14508.TTF
BodoniPS	Regular	PS_12581.TTF
BodoniPS	Bold	PS_12585.TTF
BodoniPS	Bold Italic	PS_12586.TTF
BodoniPS	Italic	PS_12582.TTF
Candid	Regular	PS_24517.TTF
Chicago	Regular	PS_24518.TTF
Clarendon Light	Regular	PS_14513.TTF
ClarendonPS	Regular	PS_10269.TTF
ClarendonPS	Bold	PS_12968.TTF
Cooper Black	Regular	PS_10369.TTF
Cooper Black	Italic	PS_10370.TTF
Copperplate32bc	Regular	PS_14514.TTF
Copperplate33bc	Regular	PS_14515.TTF
CoronetPS	Italic	PS_10249.TTF
Eurostile	Regular	PS_10267.TTF
Eurostile Bold	Regular	PS_10268.TTF
Eurostile ExtendedTwo	Bold	PS_14512.TTF
Eurostile ExtendedTwo	Regular	PS_14511.TTF
Geneva	Regular	PS_24509.TTF
GillSans	Regular	PS_13872.TTF
GillSans	Bold	PS_13874.TTF
GillSans	Bold Italic	PS_13875.TTF
GillSans Condensed	Regular	PS_14053.TTF
GillSans Condensed	Bold	PS_14054.TTF
GillSans ExtraBold	Regular	PS_14051.TTF
GillSans	Italic	PS_13873.TTF
GillSans Light	Italic	PS_13871.TTF
GillSans Light	Regular	PS_13870.TTF
Goudy	Bold	PS_12544.TTF
Goudy	Bold Italic	PS_10695.TTF

Table 2-7 Additional PS emulation fonts (continued)

Font name	Font style	File name
Goudy	Regular	PS_12542.TTF
Goudy ExtraBold	Regular	PS_12545.TTF
Goudy	Italic	PS_12543.TTF
Helvetica Condensed	Regular	PS_14526.TTF
Helvetica Condensed	Bold	PS_14528.TTF
Helvetica Condensed	Bold Italic	PS_14529.TTF
Helvetica Condensed	Italic	PS_14527.TTF
Hoefler Text	Regular	PS_24519.TTF
Hoefler Text Black	Regular	PS_24521.TTF
Hoefler Text Black	Italic	PS_24522.TTF
Hoefler Text	Italic	PS_24520.TTF
Hoefler Text Ornaments	Regular	PS_24523.TTF
Joanna MT	Regular	PS_14503.TTF
Joanna MT	Bold	PS_14505.TTF
Joanna MT	Bold Italic	PS_14506.TTF
Joanna MT	Italic	PS_14504.TTF
Letter Gothic	Italic	PS_13778.TTF
Letter GothicPS	Regular	PS_13777.TTF
Letter GothicPS	Bold	PS_13779.TTF
Letter GothicPS	Bold Italic	PS_13780.TTF
Lubalin Graph	Regular	PS_12675.TTF
Lubalin Graph	Bold	PS_12677.TTF
Lubalin Graph	Bold Italic	PS_12625.TTF
Lubalin Graph	Italic	PS_12623.TTF
MarigoldPS	Regular	PS_94073.TTF
Mona Lisa Recut	Regular	PS_14525.TTF
Monaco	Regular	PS_24524.TTF
New York	Regular	PS_24510.TTF
Optima	Regular	PS_12506.TTF
Optima	Bold	PS_12510.TTF
Optima	Bold Italic	PS_12511.TTF
Optima	Italic	PS_12507.TTF
Oxford	Italic	PS_14072.TTF
StempelGaramond Roman	Italic	PS_11546.TTF

Table 2-7 Additional PS emulation fonts (continued)

Font name	Font style	File name
StempelGaramond Roman	Regular	PS_11545.TTF
StempelGaramond Roman	Bold	PS_11547.TTF
StempelGaramond Roman	Bold Italic	PS_11548.TTF
Taffy	Regular	PS_14507.TTF
Univers 45 Light	Regular	PS_13501.TTF
Univers 45 Light	Bold	PS_14023.TTF
Univers 45 Light	Bold Italic	PS_14024.TTF
Univers 45 Light	Italic	PS_13502.TTF
Univers 47 CondensedLight	Bold	PS_14030.TTF
Univers 47 CondensedLight	Bold Italic	PS_14040.TTF
Univers 55	Regular	PS_14021.TTF
Univers 55	Italic	PS_14022.TTF
Univers 57 Condensed	Regular	PS_14029.TTF
Univers 57 Condensed	Italic	PS_14039.TTF
Univers ExtendedPS	Bold	PS_13548.TTF
Univers ExtendedPS	Regular	PS_13547.TTF
Univers ExtendedPS	Bold Italic	PS_14481.TTF
Univers ExtendedPS	Italic	PS_14480.TTF

HP Driver Deployment Utility

The HP Driver Deployment Utility (HP DDU) was created to simplify the deployment of print drivers onto a client computer. It is a simple utility that packages the printer-driver files, and the code needed to deploy them, into 2 files: an .EXE file and a .CAB file. These files are run on the client computer to copy the printer-driver files to the Windows driver store, and for network packages, to install the product.

The HP DDU works with print drivers that can be installed by an .INF file. It is designed to work with print drivers that have their files contained in one directory structure. Because this utility is generic, it does not detect how specific print drivers are packaged. It packages all files in the directory (and subdirectories) where the print driver .INF file is found. The print driver must be expanded so that the HP DDU can process the .INF file. If you download an .EXE file with the print-driver files, you need to run it first to unpack all of the files. Then, run the HP DDU to package it for deployment on the client system.

HP DDU can be used to pre-configure a print driver for deployment. When the package is run on the client computer, the new configuration file is used to configure the print driver after it is installed. This does not break WHQL certification.

If the print driver was WHQL certified, and the print-driver files are organized within one directory structure, then HP DDU will not break WHQL certification. HP DDU packages all of the files found in the printer-driver directory structure without modifying them. If printer-driver pre-configuration is done, the new configuration file is used to configure the print driver after it is installed. This does not break WHQL certification.

 **NOTE:** If you need the ability to configure unique settings for printer-driver deployment, the Universal Print Driver installer may be a better choice as an install tool. The Universal Print Driver installer allows the configuration of settings from the command line.

The HP DDU can be used with the Universal Print Driver installer, but the Universal Print Driver command line will not be accessible. The HP DDU is designed to package and stage/install print drivers. Print-driver specific features, like those found in the Universal Print Driver installer, are specific to the Universal Print Driver installer and not supported by the HP DDU.

The HP DDU installer could be used with the Universal Print Drivers to deploy a direct connect driver in traditional mode or a network install in traditional mode.

 **NOTE:** Administrative rights are necessary on the client system where the install is being performed. For a direct connect, administrative rights are only required to run the .EXE package. The user can then connect the product without administrative rights. For a network connection, the .EXE package will copy files to the driver store, create the port, install the print driver and create the printer object.

Supported operating systems

- Microsoft Windows XP
- Microsoft Windows XP 64-Bit Edition
- Microsoft Windows Server 2003
- Microsoft Windows Server 2003 64-Bit Edition
- Microsoft Windows Server 2008
- Microsoft Windows Server 2008 64-Bit Edition
- Microsoft Windows Vista

- Microsoft Windows Vista (64-bit)
- Microsoft Windows 7

Install and run the HP DDU

Install the HP DDU

Copy the files to the administrative computer. If using the self-extracting .EXE file, just copy it to the administrative computer, then double click – it will expand the files into the proper directory structure.

DDU does not require an installation program. All of the files are contained in the “Driver Deployment Utility” directory. DDU does not require any registry entries.

Run the HP DDU

1. Create the printer-driver package to deploy by opening the HP DDU application. This can be done by double clicking HPDDU.EXE, which is found in the Driver Deployment Utility root directory. This utility packages the print driver and the code needed to stage/install the print driver into an .EXE file and a .CAB file. An informational .XML file is also created and can be used to identify the package selections.
2. Run the new printer-driver package (created in step 1) on the client computer. It can be copied to the client computer and run by double clicking, or it can be run from a server by pointing to it and double clicking. The package can also be run in a batch file.

For a **direct connect package**, the HP DDU will silently copy the printer-driver files into the Windows driver store and exit. Prior to exiting, an optional dialog can be shown to prompt the user to connect their product after the files are copied. Upon completion of the package executable, when the user connects the product to the computer, the operating system will install the product using Plug and Play software.

 **NOTE:** If the product is never connected to the computer, the product will not be installed.

For a **network package**, the HP DDU will silently copy the printer-driver files into the Windows driver store, and then install the product using the network information entered by the administrator.

Use the HP DDU

The HP DDU user interface is divided into the following sections:

- **Package Source** describes the package type and printer-driver location that you want to create.
- **Package Target** identifies the name and location of the installation package.
- **Create Package** initiates the package creation process.

Figure 2-2 Package Source

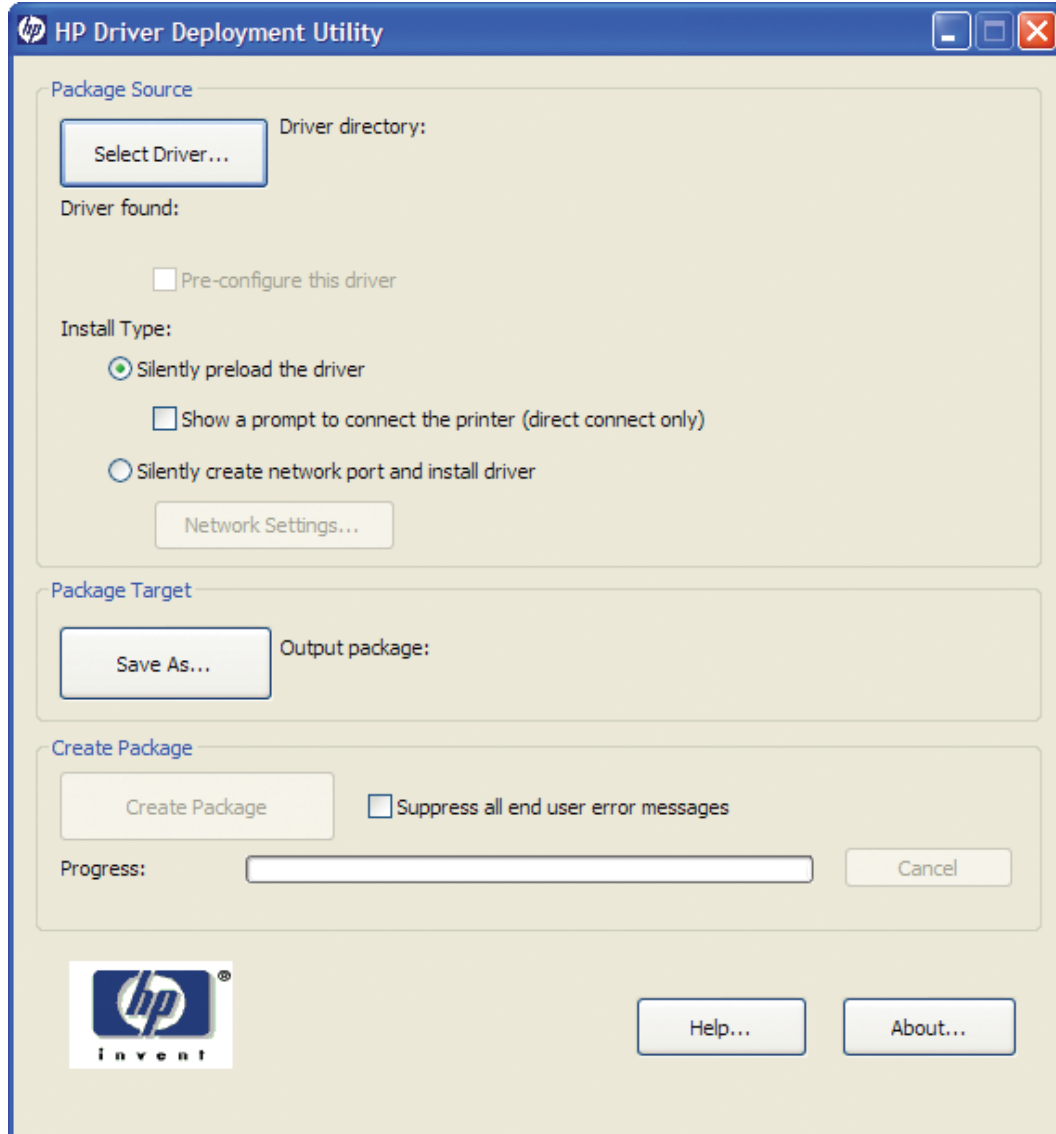

Driver Directory—Use the **Select Driver** button to enter the directory where the print driver resides by browsing or typing it in. You should only have one printer-driver package in this directory because this utility will package all the files found in this directory (and sub directories) into the executable file. If you have downloaded a compressed printer-driver package, you must expand it before using this utility.

In some cases, you may have multiple print-driver .INF files in the directory (sometimes one is for color and another for mono products). In this case, an additional dialog will allow you to select which print driver to package.

You will also get a warning if the directory is large. This is to help prevent packaging more than one print driver. You can choose to continue or not at this point.

Once the printer-driver directory is selected, and one print driver has been found, the printer-driver information is displayed below the directory selection box.

For print drivers that support preconfiguration, the check box below will be enabled. Selecting this will run a configuration dialog after clicking the **Create Package**.

Install Type—Silently preload the driver is the option to select for users that will be using a direct connection, like a USB cable. A future Plug and Play event will be necessary to install the print driver, but all the files will be installed in the Windows driver store by this package for future use.

By default the executable file runs silently. If you would like to prompt the end user to connect the product at the end of the install, select the **Show a prompt to connect the printer** checkbox.

For products using a network connection, select the **Silently create the network port and install driver** option. The **Network Settings** button will become enabled, and you should click on it to enter the required network settings.

 **NOTE:** If you do not select the print driver first, an error dialog box appears. You must select the print driver first so that the product name can be derived from the printer-driver name.

Figure 2-3 Network Settings



The screenshot shows a Windows-style dialog box titled "Network Settings". It contains two main sections: "Required Settings" and "Additional Settings".

- Required Settings:** This section is titled "Identify the network printer by one or more of the following:". It contains three text input fields:
 - IP Address: (empty)
 - Hardware Address: (empty)
 - Hostname: (empty)
- Additional Settings:** This section contains four controls:
 - Port Name: (text input containing "HPPrintPort")
 - Printer Name: (text input containing "HP Universal Printing PCL 6")
 - Set this printer as default printer?: (dropdown menu set to "No")
 - Share this Printer?: (dropdown menu set to "No")
 - Share Name: (text input, empty)

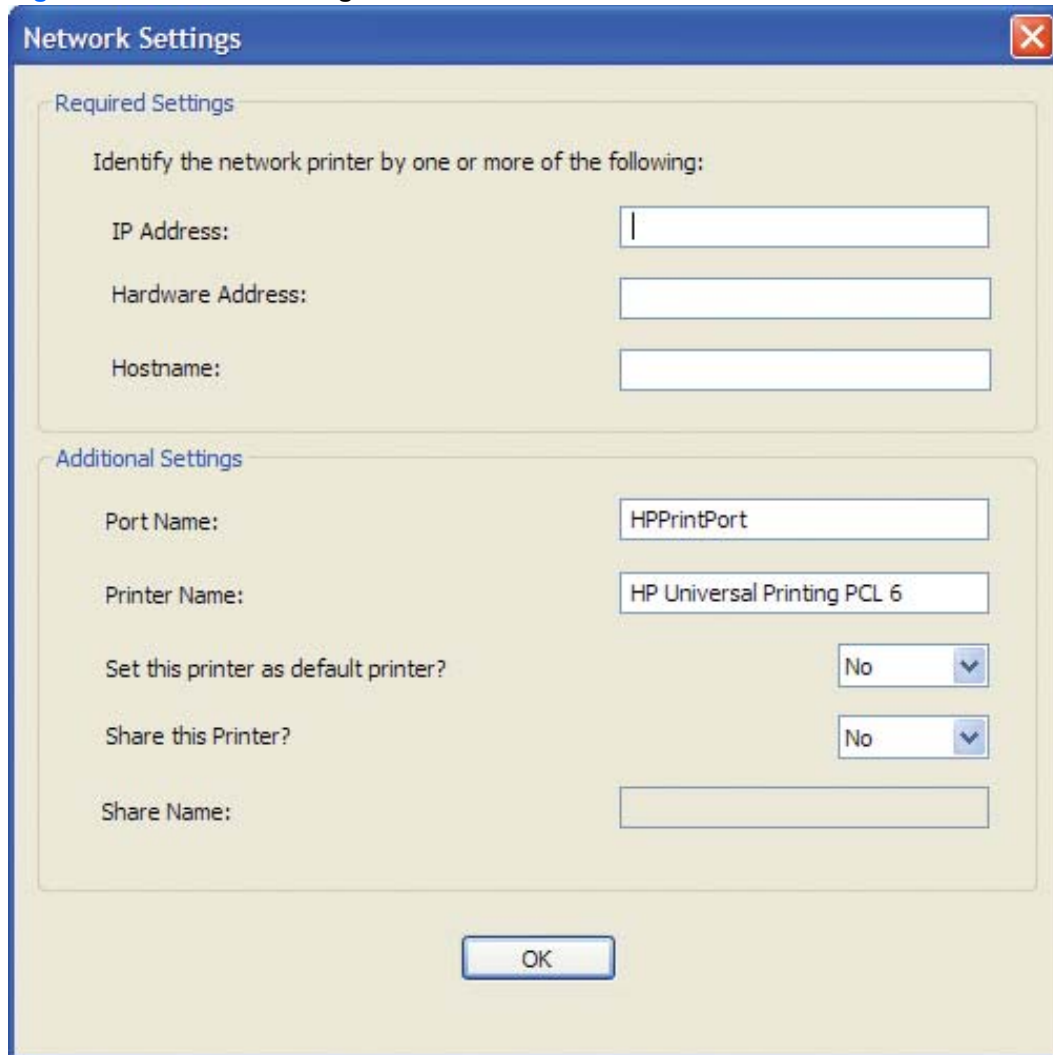
An "OK" button is located at the bottom center of the dialog.

You must identify the network product by one of the following methods. This utility does not communicate with the product to determine if the settings are valid, but it does perform syntax checking. The

administrator is responsible for identifying the product using either the correct IP address, the Hardware address, or the Hostname.

- **IP Address** — enter the IPv4 or IPv6 address of the product.
- **Hardware Address** — enter the hardware address of the product.
- **Hostname** — enter the hostname of the product.

The following network settings are additional. You may accept the default values pre-entered or change any of them.

- **Port Name:** This is the network port name that will be created. If the name already exists, a number will be appended to make it unique.
- **Printer Name:** This is the product name that will appear in the printers' folder. If the name already exists, a number will be appended to make it unique.
- **Set this printer as default:**
 - Yes - will make this product the default when printing from other applications.
 - No - will retain the current default, unless this is the only product installed.
- **Share this printer:** Yes - will allow others to use this product.
- **Share Name:** Share name for the product. Only enabled if 'Share this printer' is Yes. If the name already exists, a number will be appended to make it unique.

To exit the Network Settings dialog without saving, use the Windows close button in the upper corner.

Package Target

Use the **Save as** button to enter the name and location for the output package by browsing or typing it in. The utility will create the package in the temp directory and then move it to the final location.

Create Package

Click the **Create Package** button when you have entered all the above information. This button will be disabled until you have entered the required information. Once it is clicked, the **Cancel** button and Progress bar will be enabled.

To stop the package creation, click the **Cancel** button.

The executable file runs silently, unless a user prompt is requested for a direct-connect product. If an error is encountered during execution, an error dialog will appear. To suppress the error dialog, select the **Suppress all end user error messages** check box.

If you selected the **Pre-configure this driver** checkbox, the print driver configuration dialog will open when you click the **Create Package** button. Once you have configured the print driver, select **OK** to save the new configuration settings and continue creating the package. Clicking **Cancel** will cancel the entire package creation process.

Figure 2-4 HP DDU Driver Configuration settings

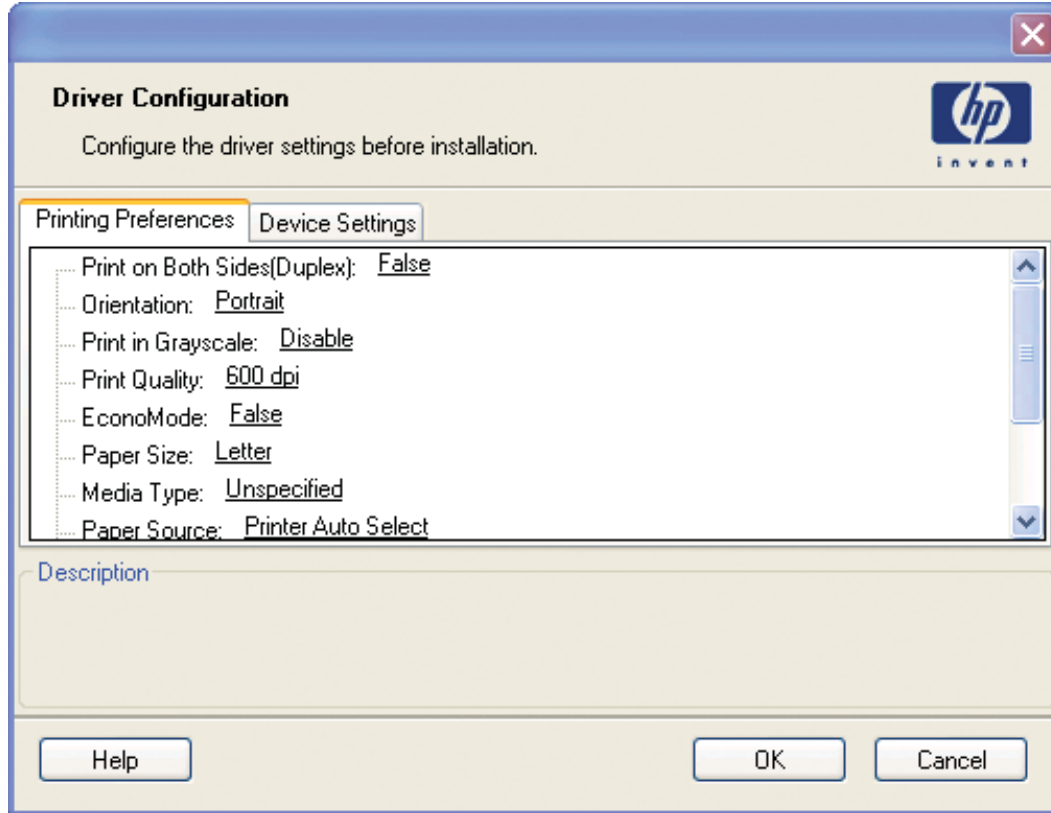

HP DDU Frequently Asked Questions

How do I use the HP DDU to deploy a direct connect driver with preconfiguration?

If you load multiple PDLs for one product, the operating system will determine which one satisfies the Plug and Play event. The operating system will create one printer object for that PDL.

1. Run HPDDU.EXE to start the package creation.
2. From Package Source section:
 - a. Select the print driver to package by browsing to the .INF file in the directory.
 - b. Select the **Pre-configuration** checkbox. This checkbox is enabled only for print drivers that support preconfiguration.
 - c. Select the **Silently preload the driver** install type.
 - d. Select the **Show a prompt to connect the printer** checkbox if you want to prompt the user after the files are copied.

3. From **Package Target** section:

Select the output name and location. Three files will be written here: an .EXE file, a .CAB file, and an .XML file with information about the package.

4. From **Create Package** section:
 - a. If you want to suppress any error messages, select the **Suppress all end user error messages** checkbox.
 - b. Click the **Create Package** button
5. Run the new .EXE file from the client computer. You must have administrator rights to run the .EXE file because it will be copying files into the Windows driver store. Now the printer-driver files are on the system, and any user can connect the product to trigger the Plug and Play event.

 **NOTE:** The printer object is not created until the product is connected.

 **NOTE:** If you deploy multiple direct connect print drivers, with preconfiguration, and they all use a pre-config file with the same name, the first one connected will be the only one configured properly. This might happen if you deploy the PCL6 and PCL5 print drivers for the same product. The reason is that the config file is copied to the \3 directory awaiting the product being connected. Each deployment will just copy over the same config file since they all use the same name. Once the product is connected, this config file gets consumed and deleted. Future Plug and Play events will not have the config file available.

How do I use the HP DDU to deploy a network product with preconfiguration?

 **NOTE:** Before running the HP DDU, you must download the driver you want to package, expand the driver, and place the driver in its own directory on the computer where the HP DDU will run.

1. Run HPDDU.EXE to create the package.
2. From **Package Source** section:
 - a. Select the print driver to package by browsing to the .INF file in the directory.
 - b. Select the **Pre-configuration** checkbox. This checkbox is enabled only for print drivers that support preconfiguration.
 - c. Select the **Silently create network port and install driver** install type.
 - d. Click the **Network Settings** button to enter the network settings.
3. From **Network Settings** dialog:
 - a. From the **Required Settings** section, enter at least one way of identifying the product (IP address, Hardware address, or Hostname).
 - b. Make any changes to the **Additional Settings** section (port name, product name, default printer, sharing and share name). You can leave the default settings if you don't need to make changes.
4. From **Package Target** section:

Select the output name and location. Three files will be written here: an .EXE file, a .CAB file and an .XML file with information about the package.

5. From **Create Package** section:
 - a. If you want to suppress any error messages, select the **Suppress all end user error messages** checkbox.
 - b. Click the **Create Package** button.
 - c. The configuration dialog will open and allow you to set configuration details for this print driver. After accepting the configuration changes, the package will be created.
6. Run the new .EXE file from the client computer. You must have administrator rights to run the .EXE file because it will be copying files into the Windows driver store. A port and printer object will be created with the information provided above.

Common Problems

I get a warning when I select the print driver.

If there are too many files in the driver directory, or the directory is really large, a warning appears so that the user doesn't accidentally package up something they didn't intend to (like the root directory). Some print drivers are really large, and you can choose to ignore this warning and continue.

To minimize package size, each print driver should be in its own directory. This is usually the default behavior when you expand a print driver.

I get an error when I try to open the "Network Settings" dialog.

You need to first select a print driver before opening the "Network Settings" dialog. This populates the product name field based on the printer-driver name.

The Create Package button is not enabled.

This button will not be enabled until you have:

1. Selected the print driver.
2. If network connect – filled out one of the required network settings.
3. Selected the **Save as** name and directory.

How do I exit the HP DDU?

Use the Windows close button in the upper corner.

The Network Settings dialog keeps displaying an error, and I just want out.

If you do not want to save settings, or change your mind and don't want a network install, you need to close the network settings dialog with the Windows close button in the upper corner. Using the **OK** button, will try to validate the settings, and that is what is causing an error.

What if the user connects the printer before the HP DDU package is run?

If the user connects the product, but then cancels the Plug and Play event before it finishes, this creates an incomplete Plug and Play event. After copying the printer-driver files to the Windows driver store, the HP DDU code will cleanup incomplete Plug and Play events for products supported by this print driver. Then it will refresh the bus, causing the operating system to Plug and Play the product (installing the print driver and creating the printer object.)

How do I uninstall HP DDU?

Delete all the files in the root HP DDU directory.



NOTE: No registry changes have been made with this utility.

3 Install Windows software and utilities

Introduction

The HP Color LaserJet Enterprise CP4020-CP4520 Series product comes with software and installers for Microsoft Windows and Apple, Inc., Macintosh systems. Linux and UNIX systems are supported, and software is available on the Web.

This chapter provides procedures for installing and removing the HP Color LaserJet Enterprise CP4020-CP4520 Series printing-system software for Windows operating systems. The chapter provides information about these topics:

- [Supported operating systems for Windows](#)
- [General Microsoft Windows installation instructions](#)
- [Detailed Microsoft Windows installation instructions](#)
- [Uninstall instructions](#)

 **NOTE:** If the computer is running a 64-bit Windows operating system, you must install the corresponding 64-bit print driver. For instructions, see [Install the print driver using the Microsoft Add Printer Wizard on page 56](#).

Supported operating systems for Windows

Windows operating systems provide full-featured support for the HP Color LaserJet Enterprise CP4020-CP4520 Series product. Operating systems that are not described here provide varying levels of functionality.

Windows XP is used to denote Windows XP Home Edition, Windows XP Professional, and Windows XP Media Edition unless noted otherwise. Windows Vista is used to denote Windows Vista Home Basic, Windows Vista Home Premium, Windows Vista Business, and Windows Vista Ultimate unless noted otherwise.

The following operating systems support the HP Color LaserJet Enterprise CP4020-CP4520 Series product:

- Windows XP (32-bit and 64-bit)
- Windows Server 2003 (32-bit and 64-bit)
- Windows Server 2008 (32-bit and 64-bit)
- Windows Vista (32-bit and 64-bit)
- Windows 7 (32-bit and 64-bit)

In any of the supported operating systems, you must have administrator privileges to install the HP Color LaserJet Enterprise CP4020-CP4520 Series printing-system software.

For more information about the HP Color LaserJet Enterprise CP4020-CP4520 Series product, go to the following Web site:

www.hp.com/support/cljcp4025 or www.hp.com/support/cljcp4525

System requirements

The system requirements for installing and using the HP Color LaserJet Enterprise CP4020-CP4520 Series printing-system software for Windows and Macintosh are as follows:

- Same system requirements for running the supported Windows operating system (OS)
- Latest operating system updates installed through Windows Update
- 500 MB of available hard-disk space
- Mac OS X v10.4, v10.5, and later with 150 MB of free hard-disk space
- CD drive, DVD drive, or Internet connection
- Dedicated universal serial bus (USB 1.1 or 2.0) connectivity port or network connection

Print driver support in other operating systems

The HP Color LaserJet Enterprise CP4020-CP4520 Series product is also supported in the following operating environments:

- Mac OS X v10.4 or later. For more information, go to the following Web site:
www.hp.com/go/cljcp4025_software or www.hp.com/go/cljcp4525_software
- Linux. For more information, go to the following Web sites:
www.hp.com/go/linuxprinting and www.hplip.net
- UNIX. For more information, go to the following Web site:
www.hp.com/go/jetdirectunix_software
- UNIX model scripts. Available *only* on the Web at the following Web site:
www.hp.com/go/unixmodelscripts.
- Citrix Presentation Server 4.0 and 4.5
- Citrix XenApp Server 5.0
- Windows 2003 and 2008 Terminal Services
- Novell NetWare v6.5 SP7
- Novell iPrint Client for Windows v5.12
- Novell iManager v2.7
- SAP printing. For more information, go to the following Web sites:
www.hp.com/go/sap/print and www.hp.com/go/sap/drivers

General Microsoft Windows installation instructions

These are instructions for installing the print drivers on various Windows operating systems.

Installation is similar for the Windows XP, Windows Server 2003, Windows Server 2008, Windows Vista, and Windows 7 operating systems.

If the HP Color LaserJet Enterprise CP4020-CP4520 Series product is connected through a file or print server, the printing-system software must first be installed on the server before being installed on any client systems. If the HP LaserJet printing-system software is not first installed on the server, then bidirectional communication and some driver autoconfiguration methods are not available to the client systems.

Microsoft Windows installation for direct connections

The printing-system software should be installed *before* the product is connected to the computer through the USB connection and turned on. During the installation process, the software prompts you to connect the product.

Install from the printing-system CD

Follow these instructions to install the printing system from the CD that came with the product.

1. Quit all software programs.
2. Insert the CD in the CD-ROM drive.

 **NOTE:** If the CD does not start automatically, click **Start**, click **Run**, and then browse to and double-click the SETUP.EXE file in the root directory of the CD.

NOTE: In Windows Vista, you will be prompted to elevate the permissions to administrator in order to complete the installation process.

3. Click **Install Now**, and then follow the onscreen prompts.

Install the print driver using the Microsoft Add Printer Wizard

 **NOTE:** You can return to the previous screen by clicking the **< Back** button, or exit the Add Printer Wizard by clicking the **Cancel** button.

Select one of the following three options to install The print driver using the Microsoft Add Printer Wizard:

- **Use an existing port for a direct connection:** The product is connected to the computer using a USB cable or is connected via the network without using a print server and the printer port already exists.
- **Create a new TCP/IP port for a direct connection:** The product is connected via the network without using a print server and the printer port does not exist.
- **Print server connection:** The product is connected via the network using a print server.

Use an existing port for a direct connection

Perform the following when the product is connected to the computer using a USB cable or when printing via the network without using a print server:

1. On the **Start** menu, click the **Settings** option, and then
Windows XP Home: Click the **Printers and Other Hardware Devices** option.
-or-
Windows XP Professional, Windows Server 2003, and Windows 2008: Click the **Printers and Faxes** option.
-or-
Windows Vista or Windows 7: Under the **Hardware and Sound** category, click the **Printer** option.
2. Click the **Add a printer** option. The Add Printer Wizard opens.
3. Click the **Next** button on the **Add Printer Wizard** welcome dialog box.
4. If the product is connected to the computer using a USB cable or is connected via the network without using a print server, select the **Local printer attached to this computer** option, and then click the **Next >** button.

 **NOTE:** If you select the **Automatically detect an install my Plug and Play printer** check box prior to clicking the **Next >** button, the computer will automatically install the print driver.

NOTE: If the product is connected via the network using a print server, select the **A network printer, or a printer attached to another computer** option (Point and Print installation), and then click the **Next >** button. For detailed installation instructions, see [Print sever connection on page 66](#).

Figure 3-1 Add Printer Wizard — Local or Network Printer screen

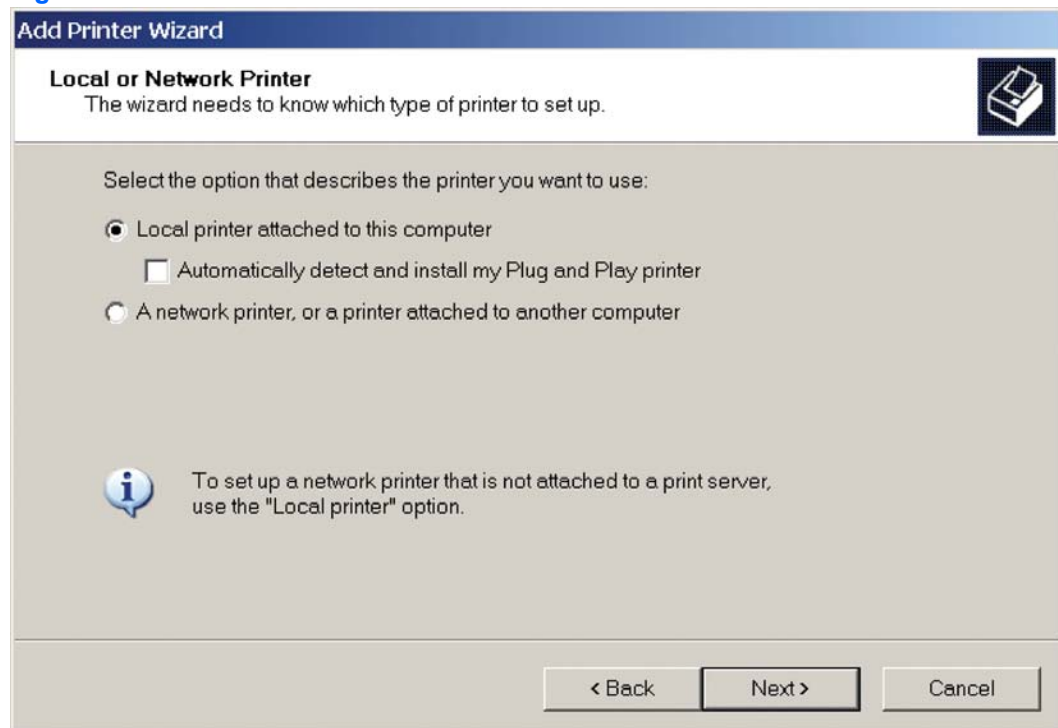

5. If the product is connected to the computer using a USB cable or is connected via the network without using a print server and the printer port already exists, select the **Use the following port** option, select the product name, print path, or IP address of the product from the **Use the following port** drop-down list, and then click the **Next >** button.

 **NOTE:** If the printer port does not appear in the **Use the following port** drop-down list, see [Create a new TCP/IP port for a direct connection on page 63](#). If the product is connected via the network using a print server, see [Print sever connection on page 66](#).

Figure 3-2 Add Printer Wizard — Select a Printer Port screen



- (Optional) Click the **Windows Update** button to display a list of drivers that can be downloaded from the Microsoft Windows Update Web site.

If the appropriate model of HP Color LaserJet Enterprise CP4020-CP4520 Series is already listed, select it and click the **Next >** button. If the product is not listed, click the **Have Disk** button to continue to the **Install From Disk** screen.

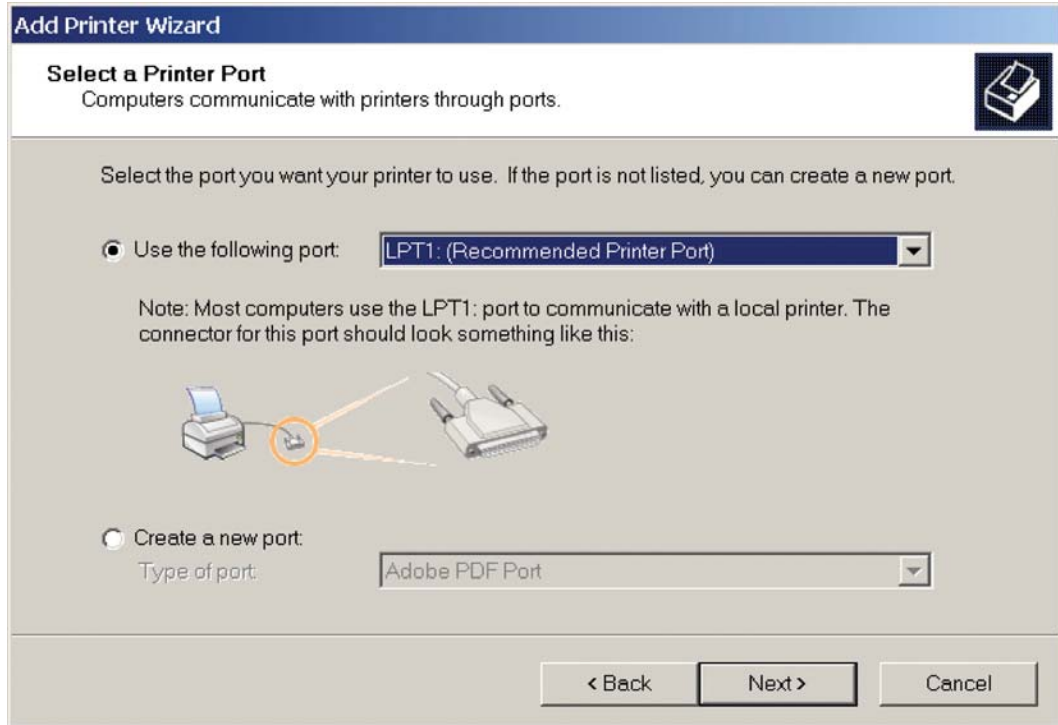
Figure 3-3 Add Printer Wizard — Install Printer Software screen

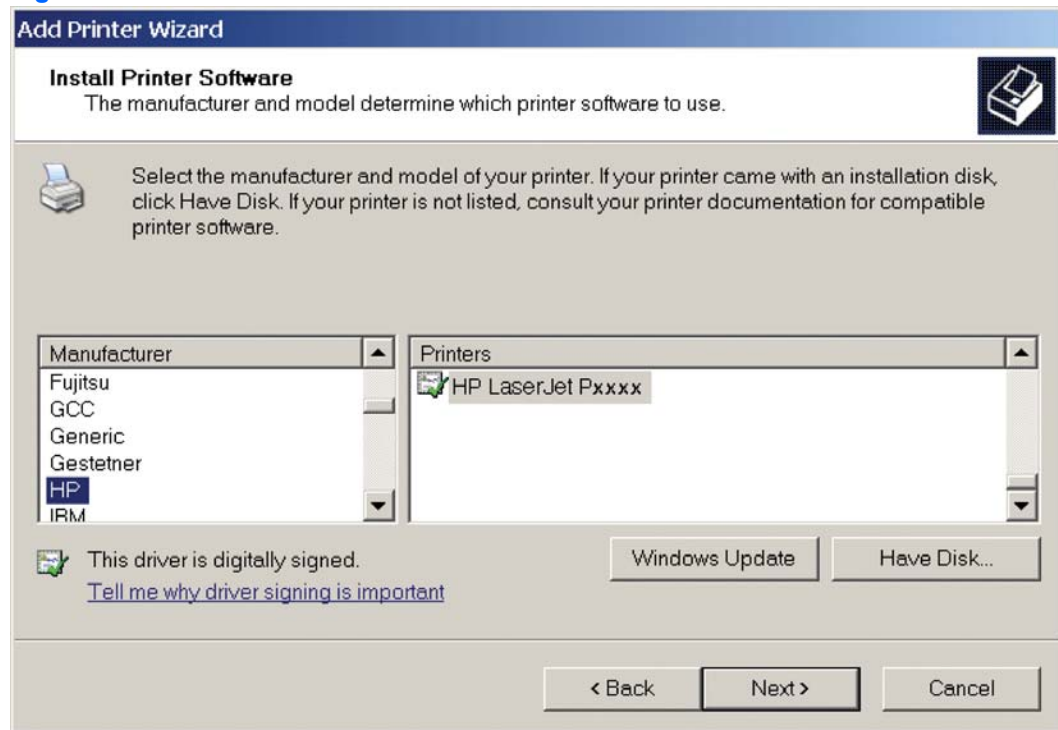

- If the correct path to the CD-ROM drive is listed in the **Copy manufacturer's files from** text box, click the **OK** button. If not, click the **Browse** button to continue to the **Locate File** screen.

Figure 3-4 Add Printer Wizard — Install from Disk screen

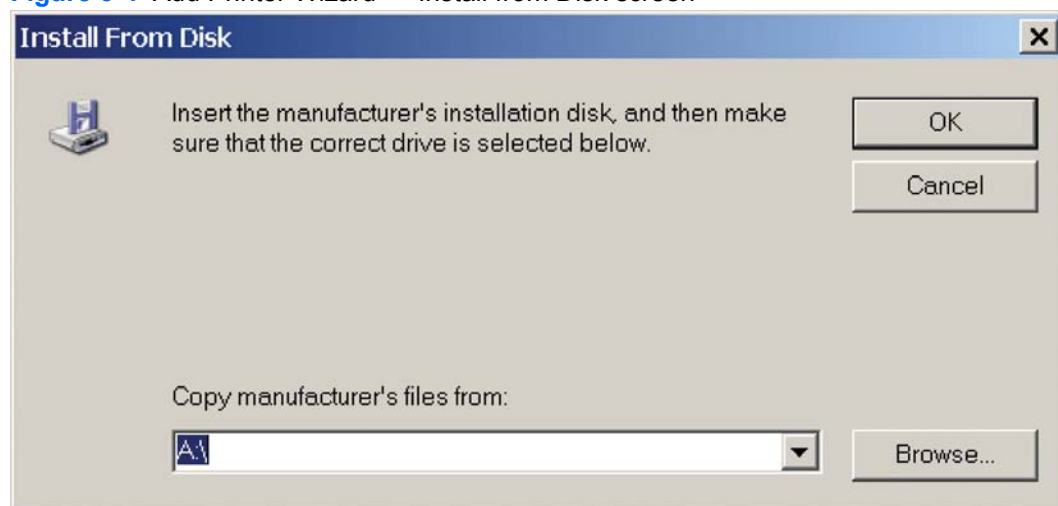

- Navigate to your CD-ROM drive, and then select the .INF file for your product.
- Click the **OK** button to continue to the **Install Printer Software** screen.

10. Select the appropriate model of HP Color LaserJet Enterprise CP4020-CP4520 Series from the list and click the **Next >** button to continue to the **Name Your Printer** screen.

Figure 3-5 Add Printer Wizard — Install Printer Software, screen 2

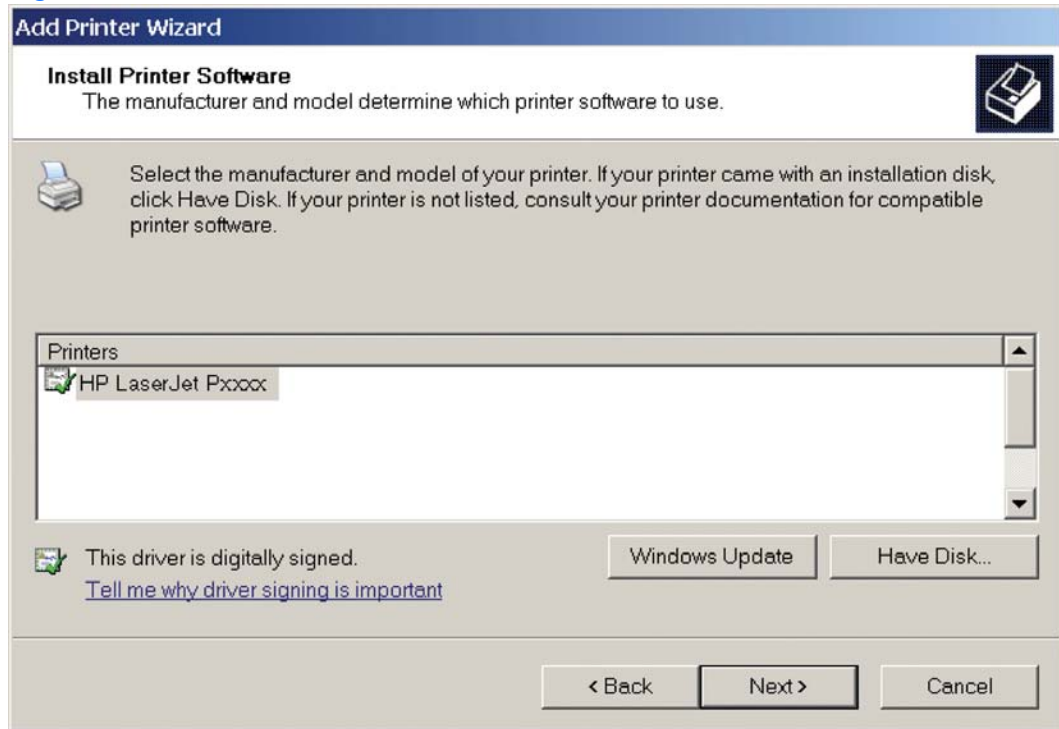

11. You can either type a name for the product in the **Printer name** text box or use the default name provided.

Select the **Yes** option to use this printer as the default printer or select the **No** option to keep the existing product as the default printer.

Click the **Next >** button to continue to the **Printer Sharing** screen.

Figure 3-6 Add Printer Wizard — Name Your Printer screen

Add Printer Wizard

Name Your Printer
You must assign a name to this printer.

Type a name for this printer. Because some programs do not support printer and server name combinations of more than 31 characters, it is best to keep the name as short as possible.

Printer name:
HP LaserJet Pxxxx

Do you want to use this printer as the default printer?

Yes
 No

< Back Next > Cancel

12. Select either the **Do not share this printer** option, or select the **Share name:** option and type share name, and then click the **Next >** button to continue to the **Print Test Page** screen.

 **NOTE:** For more information, see [Point and Print installation for Windows on page 76](#).

Figure 3-7 Add Printer Wizard — Printer Sharing screen

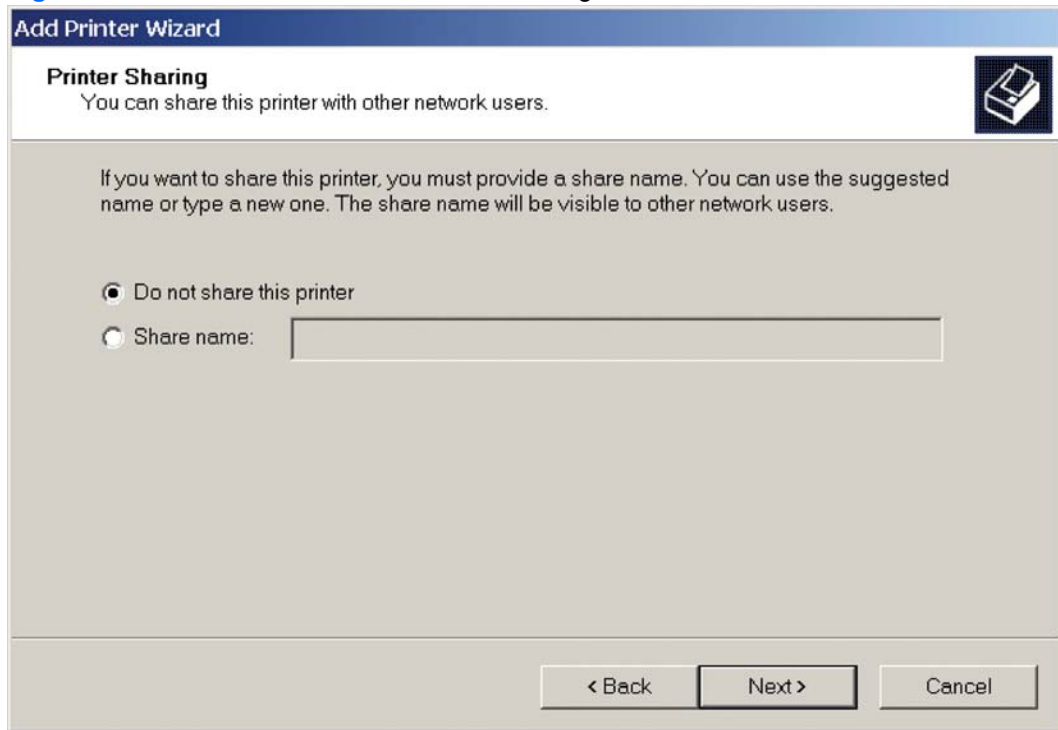

13. Select the **Yes** option if you want to print a test page after the software is installed. Select the **No** option if you do not want to print a test page after the software is installed.

Click the **Next >** button to continue to the **Completing the Add Printer Wizard** screen.

Figure 3-8 Add Printer Wizard — Print Test Page screen

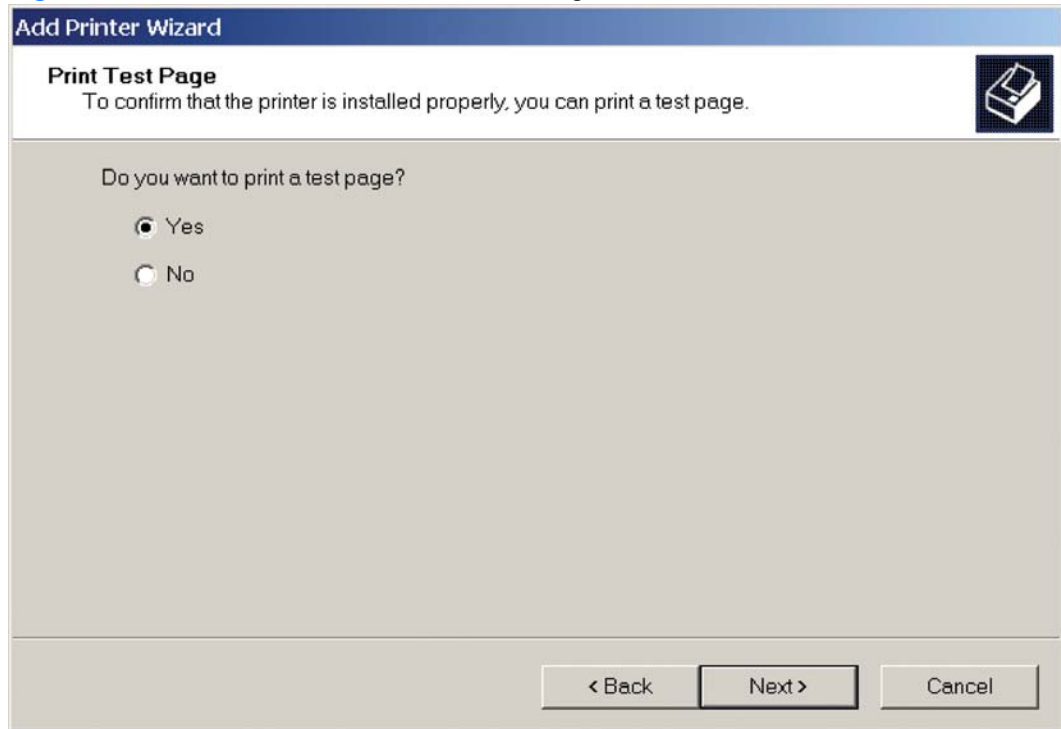

14. Review the installation details, and then click the **Finish** button to complete the Add Printer Wizard.

Create a new TCP/IP port for a direct connection

Perform the following when the product is connected via the network without using a print server and a printer port does not exist:

1. On the **Start** menu, click the **Settings** option, and then

Windows XP Home: Click the **Printers and Other Hardware Devices** option.

-or-

Windows XP Professional, Windows Server 2003, and Windows Server 2008: Click the **Printers and Faxes** option.

-or-

Windows Vista or Windows 7: Under the **Hardware and Sound** category, click the **Printer** option.

2. Click the **Add a printer** option on the **Printer Tasks** pane.
3. Click the **Next** button on the **Add Printer Wizard** welcome dialog box.

4. If the product is connected to the computer using a USB cable, or is connected via the network without using a print server, select the **Local printer attached to this computer** option, and then click the **Next >** button.

 **NOTE:** If you select the **Automatically detect and install my Plug and Play printer** check box prior to clicking the **Next >** button, the computer will automatically install the print driver.

NOTE: If the product is connected via the network using a print server, select the **A network printer, or a printer attached to another computer** option (Point and Print installation), and then click the **Next >** button. For detailed installation instructions, see [Print sever connection on page 66](#).

Figure 3-9 Local or Network Printer screen

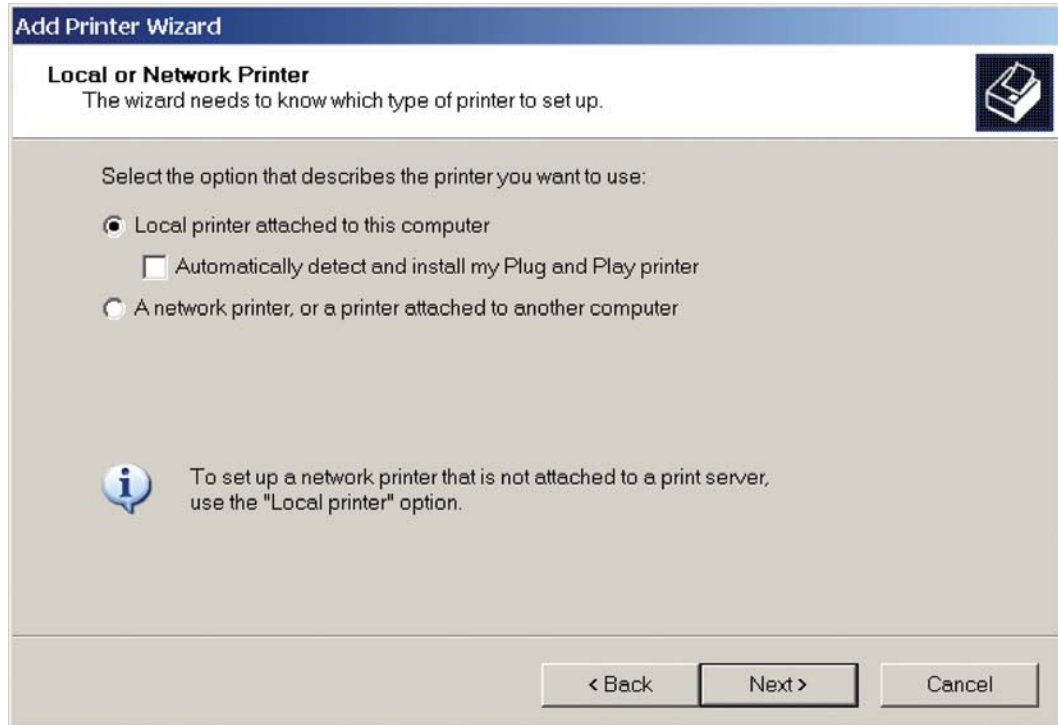

5. If the printer port does not appear in the **Use the following port** drop-down list, select the **Create a new port** option.
 - If the **HP Standard TCP/IP Port** option appears in the **Type of port** drop-down list, select this option, and then click the **Next** button. The **Welcome to the Add Standard TCP/IP Printer Port Wizard** dialog box appears.
 - If the **HP Standard TCP/IP Port** option does not appear in the **Type of port** drop-down list, select the **Standard TCP/IP Port** option from the **Type of port** drop-down list, and then click the **Next** button. The **Welcome to the Add Standard TCP/IP Printer Port Wizard** dialog box appears.

 **NOTE:** The **HP Standard TCP/IP Port** option provides additional network functionality and is the recommended printer port for HP products.

NOTE: If the printer port already appears in the **Use the following port** drop-down list, see [Use an existing port for a direct connection on page 57](#). If the product is connected via the network using a print server, see [Print sever connection on page 66](#).

Figure 3-10 Select a Printer Port screen

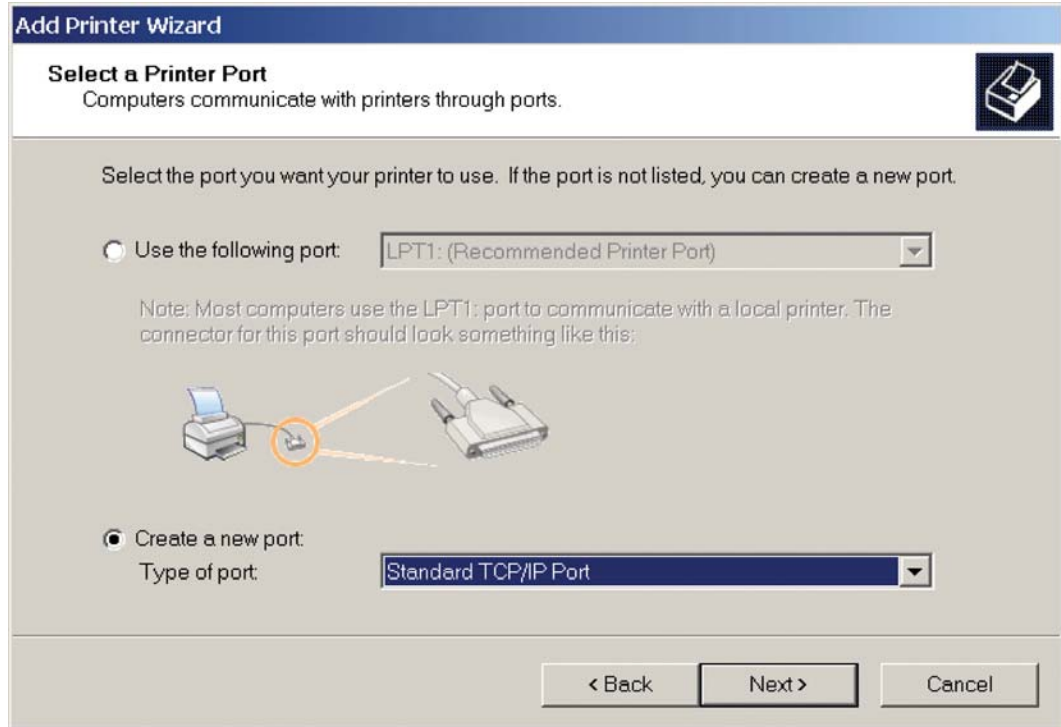

6. Click the **Next >** button.

Figure 3-11 Add Standard TCP/IP Printer Port screen



7. Type the product's IP address or host name in the **Printer Name or IP Address** text box, and then click the **Next** button.

 **NOTE:** The default port name is the name that you typed in the **Printer Name or IP Address** text box. You can change this name by typing a new name in the **Port Name** text box.

NOTE: The **Always print to this device, even if its IP address changes** check box is only available if you select the **HP Standard TCP/IP Port** option from the **Select a Printer Port** dialog box. This feature allows the computer to communicate with the product using the MAC address of the network card rather than the IP address.

Figure 3-12 Add Port screen

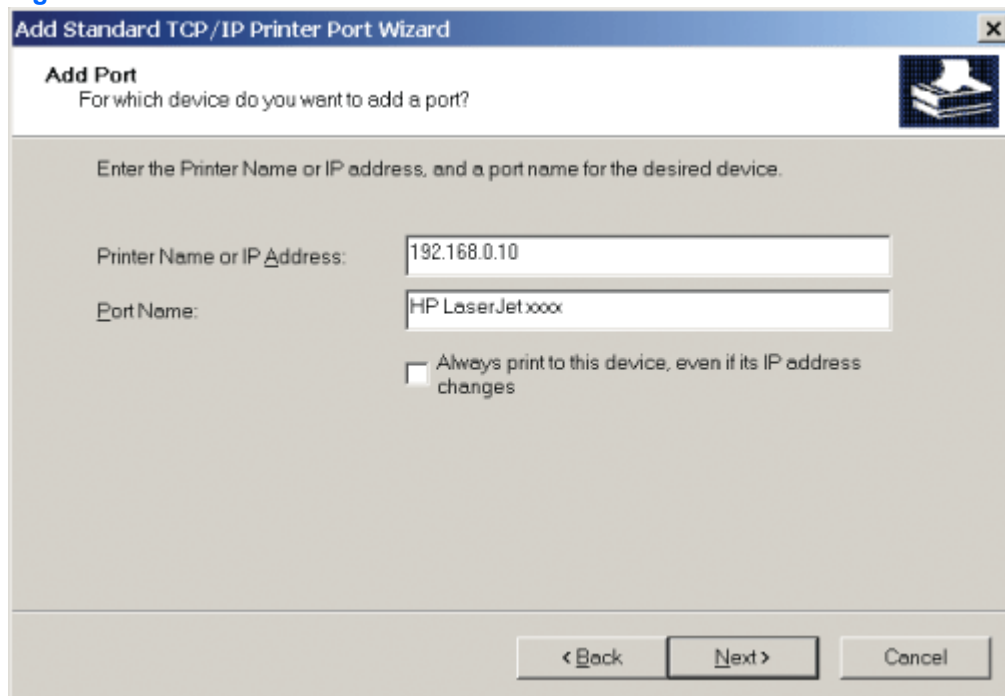

8. Review the installation details, and then click the **Finish** button to complete the Add Printer Wizard.

Print sever connection

Perform the following when the product is connected via the network using a print server:

1. On the **Start** menu, click the **Settings** option, and then
Windows XP Home: Click the **Printers and Other Hardware Devices** option.
-or-
Windows XP Professional, Windows Server 2003, and Windows Server 2008: Click the **Printers and Faxes** option.
-or-
Windows Vista or Windows 7: Under the **Hardware and Sound** category, click the **Printer** option.
2. Click the **Add a printer** option. The Add Printer Wizard opens.
3. Click the **Next** button on the **Add Printer Wizard** welcome dialog box.

4. If the product is connected via the network using a print server, select the **A network printer, or a printer attached to another computer** option, and then click the **Next >** button.

 **NOTE:** If the product is connected to the computer using a USB cable, or is connected via the network without using a print server, select the **Local printer attached to this computer** option, and then click the **Next >** button. You can also select the **Automatically detect and install my Plug and Play printer** check box prior to clicking the **Next >** button to have the computer automatically install the print driver. For detailed installation instructions, see either [Use an existing port for a direct connection on page 57](#) or see [Create a new TCP/IP port for a direct connection on page 63](#).

Figure 3-13 Add Printer Wizard — Local or Network Printer screen



5. Select either the **Find a printer in the directory** option, the **Connect to this printer (or to browse for a printer, select this option and click Next)** option, or the **Connect to a printer on the Internet or on a home or office network** option, and then click the **Next >** button.

Figure 3-14 Add Printer Wizard — Specify A Printer screen

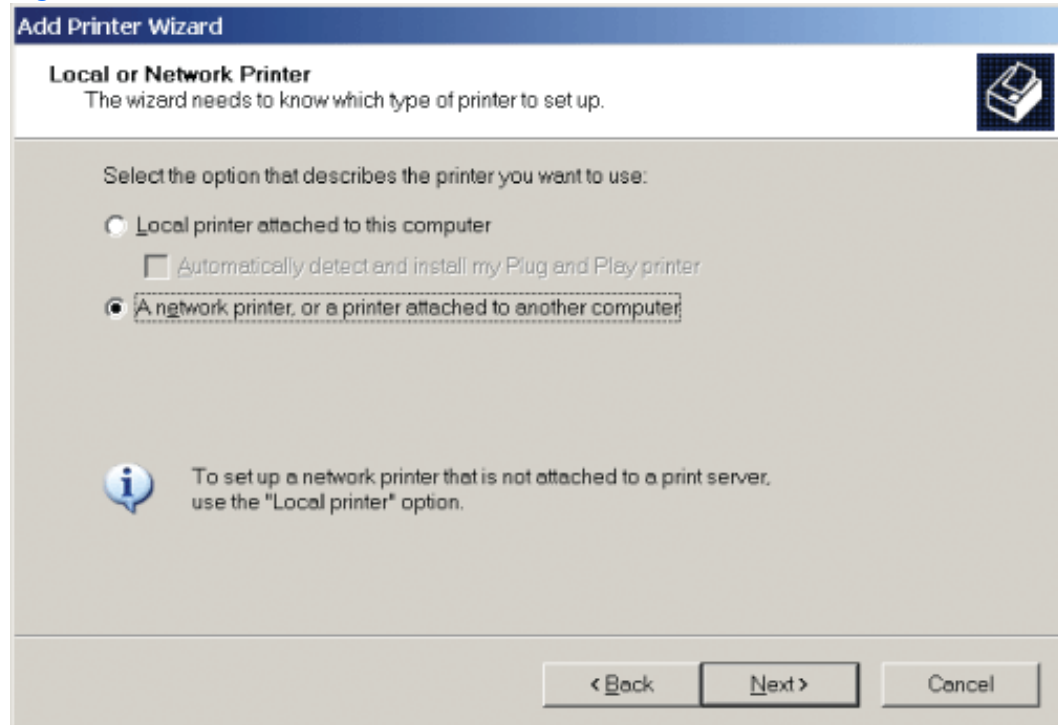
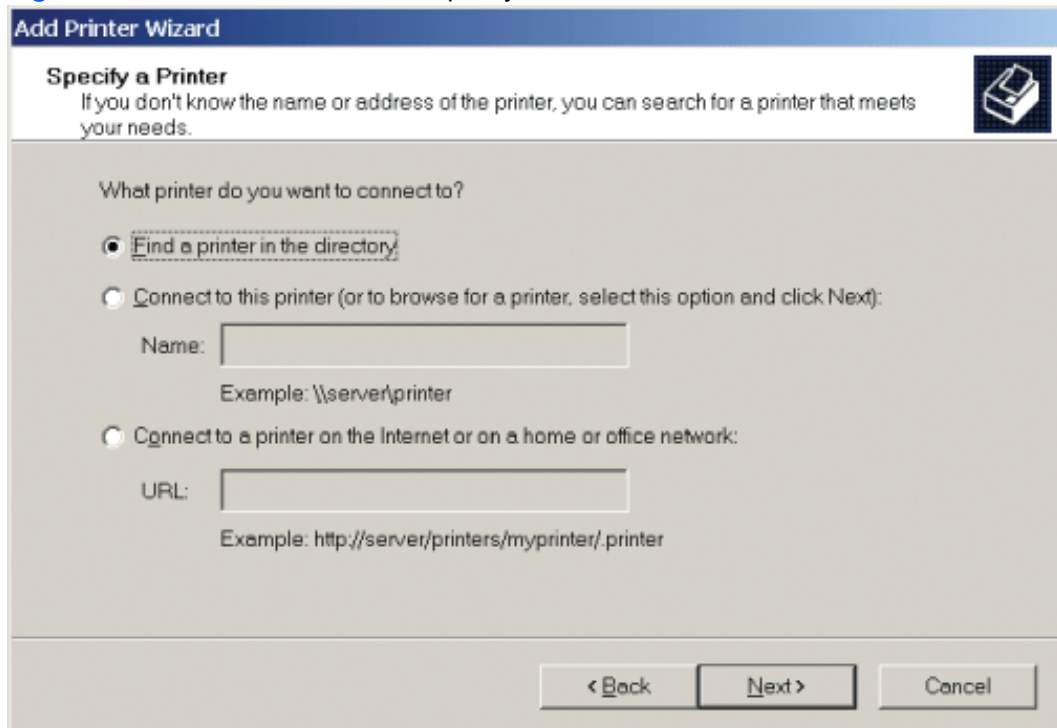

If you select the **Find a printer in the directory** option and then click the **Next >** button, you will continue to the **Find Printers** dialog box.

If you select the **Connect to this printer (or to browse for a printer, select this option and click Next)** option and then click the **Next >** button, you will continue to the **Browse for Printer** dialog box.

If you select the **Connect to a printer on the Internet or on a home or office network** option and then click the **Next >** button, you will continue to the **Completing the Add Printer Wizard** dialog box.

Select one of the following options:

a. (Find a printer in the directory option only)

Specify search attributes to find your product on the network, and then click the **Find Now** button to search the specified location for your product. Once the search has completed, select the product, and then click the **OK** button to continue to the **Default Printer** dialog box.

Figure 3-15 Add Printer Wizard — Find Printers screen

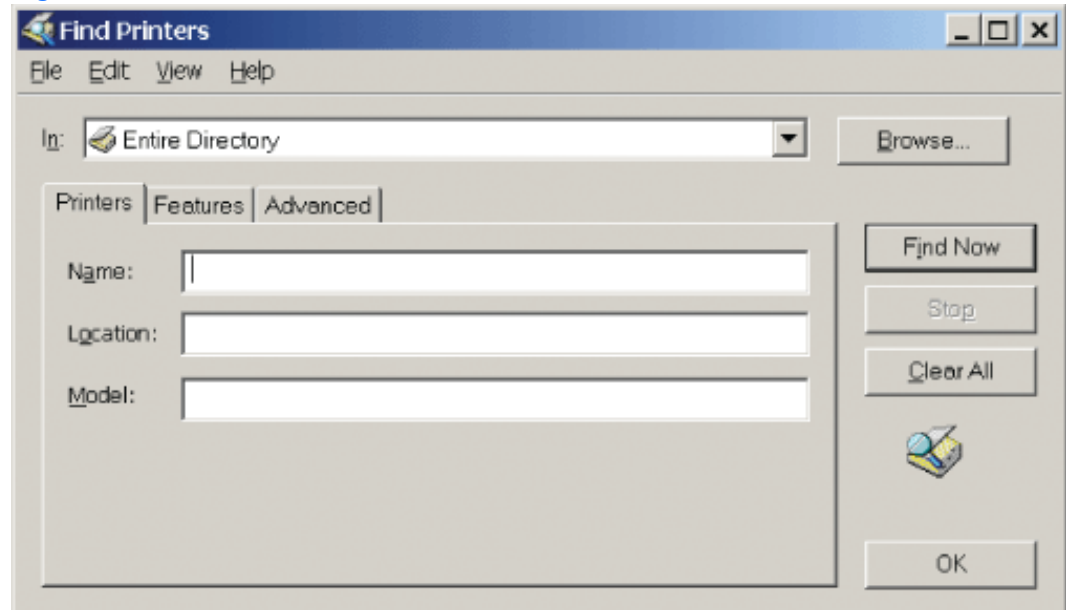

Select either the **Yes** option to use this printer as the default printer, or select the **No** option to keep the existing product as the default printer, and then click the **Next >** button to continue to the **Completing the Add Printer Wizard** dialog box.

Figure 3-16 Add Printer Wizard — Default Printer screen

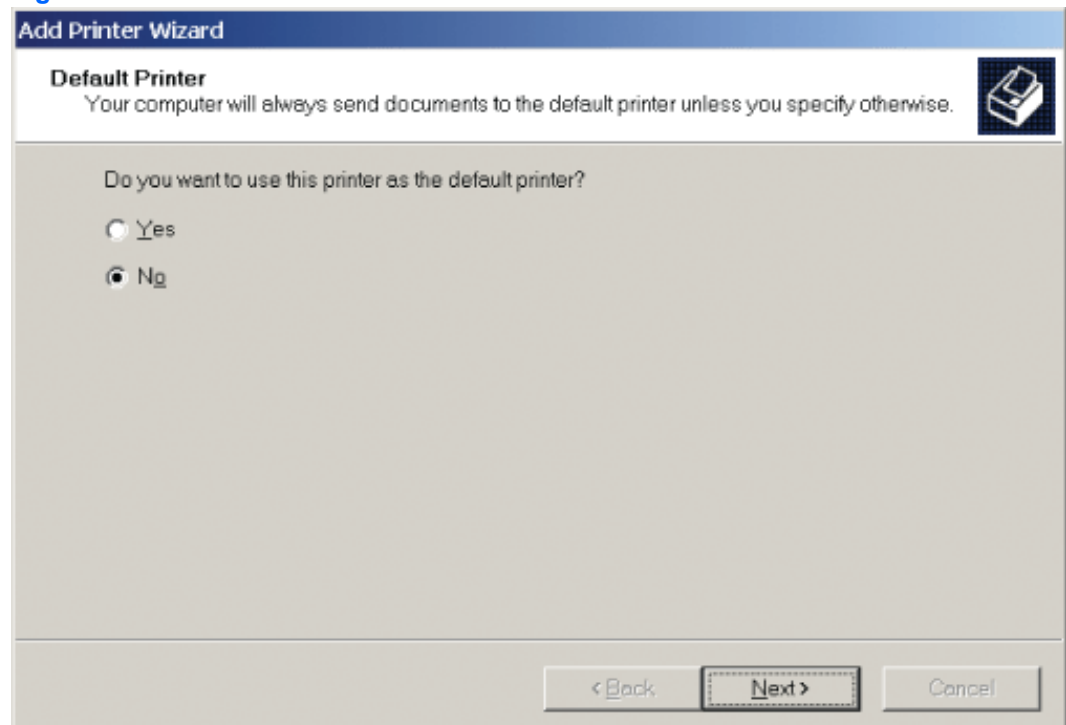

- b. (Connect to this printer (or to browse for a printer, select this option and click Next) option only)

Specify the print path for the product and then click the **Next >** button. The computer will search the network for shared products. Select the product from the list and then click the **Next >** button to continue to the **Completing the Add Printer Wizard** dialog box.

Figure 3-17 Add Printer Wizard — Browse for Printer screen

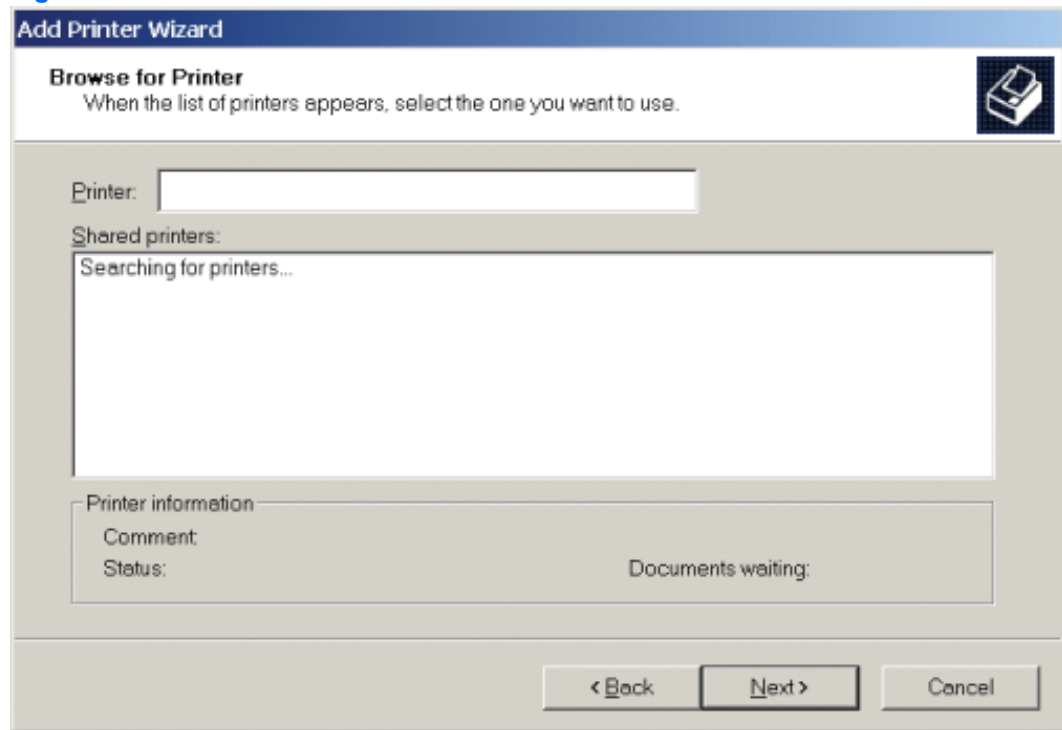

- c. (Connect to a printer on the Internet or on a home or office network option only)

Type the URL for the product, and then click the **Next >** button. Follow the onscreen instructions to connect to the product, and then you will continue to the **Completing the Add Printer Wizard** dialog box.

6. Review the installation details, and then click the **Finish** button to complete the Add Printer Wizard.

Microsoft Windows installation for computers on a network

Install the driver from a network location or from downloaded files

Follow these instructions if you are installing the printing-system files from a network location or from downloaded files. You might need to see your network administrator for the location of the printing-system software file.

1. Browse to the location of the SETUP.EXE file.
2. Double-click the SETUP.EXE file.
3. Click **Install** and continue to follow the instructions until the product is installed. For detailed installation instructions, see [Detailed Microsoft Windows installation instructions on page 78](#).

Install the driver using downloaded files and the HP Driver Installation Utility (HPDIU)

Follow these instructions if you downloaded the driver from the Web that is compatible with the HPDIU installation. This driver uses the HPDIU to install the driver on network computers.

1. Close all programs.
2. Browse to the location of the SETUP.EXE file.
3. Double-click the SETUP.EXE file.
4. Read the license agreement, and then click the **Accept** button to continue to the **Device Connection** screen.

Figure 3-18 Software Installation — License Agreement screen

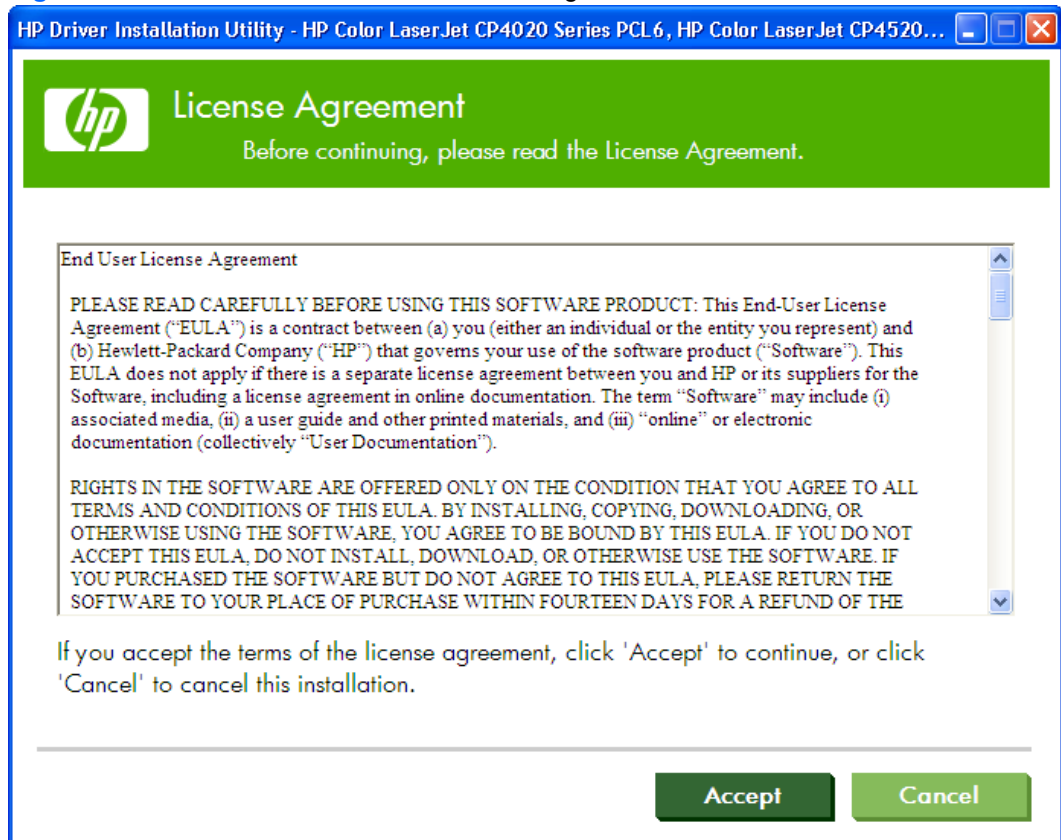

5. Select an option for how the device will be connected to the computer.

Figure 3-19 Software Installation — Device Connection screen

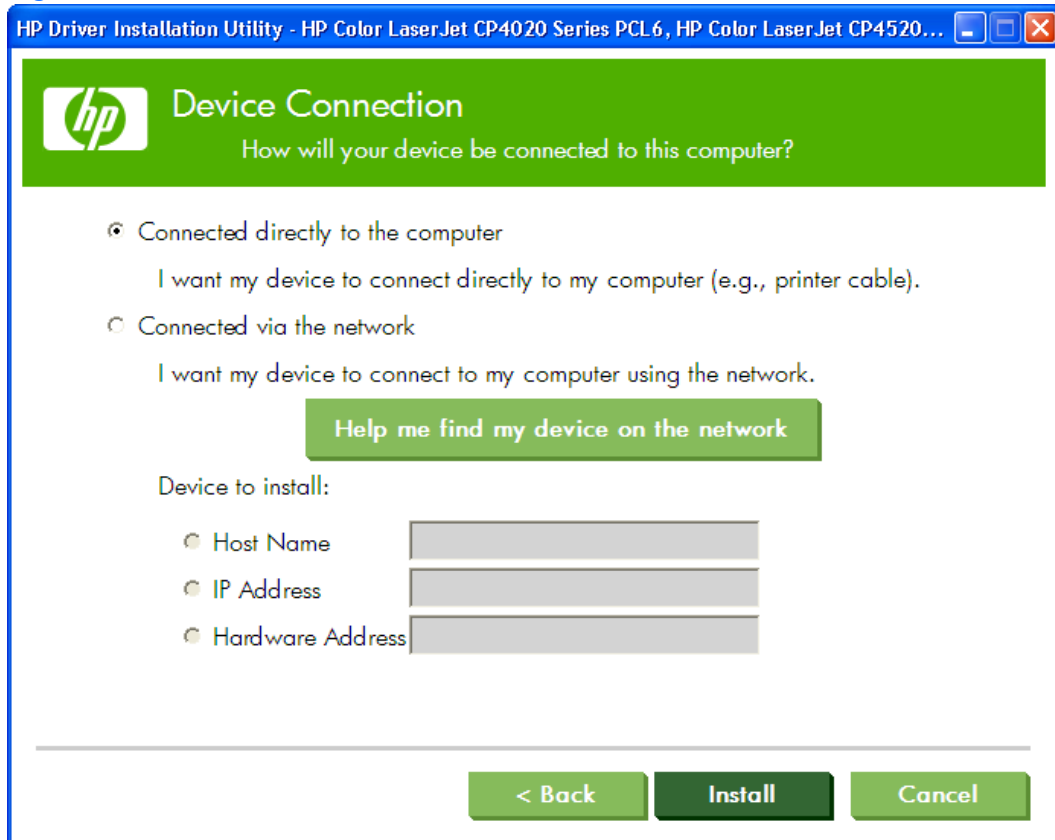





If the device is connected to the product using a USB cable, select the **Connected directly to the computer** option and then click the **Install** button. Once the software is installed, you will continue to the **Driver Installation Complete** screen.

If the device's networking settings are known, select the **Connected via the network** option, enter either the Host Name, IP Address, or the Hardware Address, and then click the **Install** button. Once the software is installed, you will continue to the **Driver Installation Complete** screen.

If the product's network settings are not known, click the **Help me find my device on the network** button. You will continue to the **Devices Found** screen once the computer has finished searching the network for HP Color LaserJet Enterprise CP4020-CP4520 Series products.

 **NOTE:** To find the product network settings, follow these directions to print a configuration page from the product control panel.

Print a configuration page

- a. Press the **Home** button  to open the menus.
- b. Press the **up arrow**  or the **down arrow**  to scroll to **INFORMATION**, and then press **OK**.
- c. Press the **up arrow**  or the **down arrow**  to scroll to **PRINT CONFIGURATION**.
- d. Press **OK** to print the configuration page.

6. A list of HP Color LaserJet Enterprise CP4020-CP4520 Series products is displayed. Select the product you want to install and click the **OK** button to continue to the **Device Connection** screen.

Figure 3-20 Device Connection — Devices Found screen

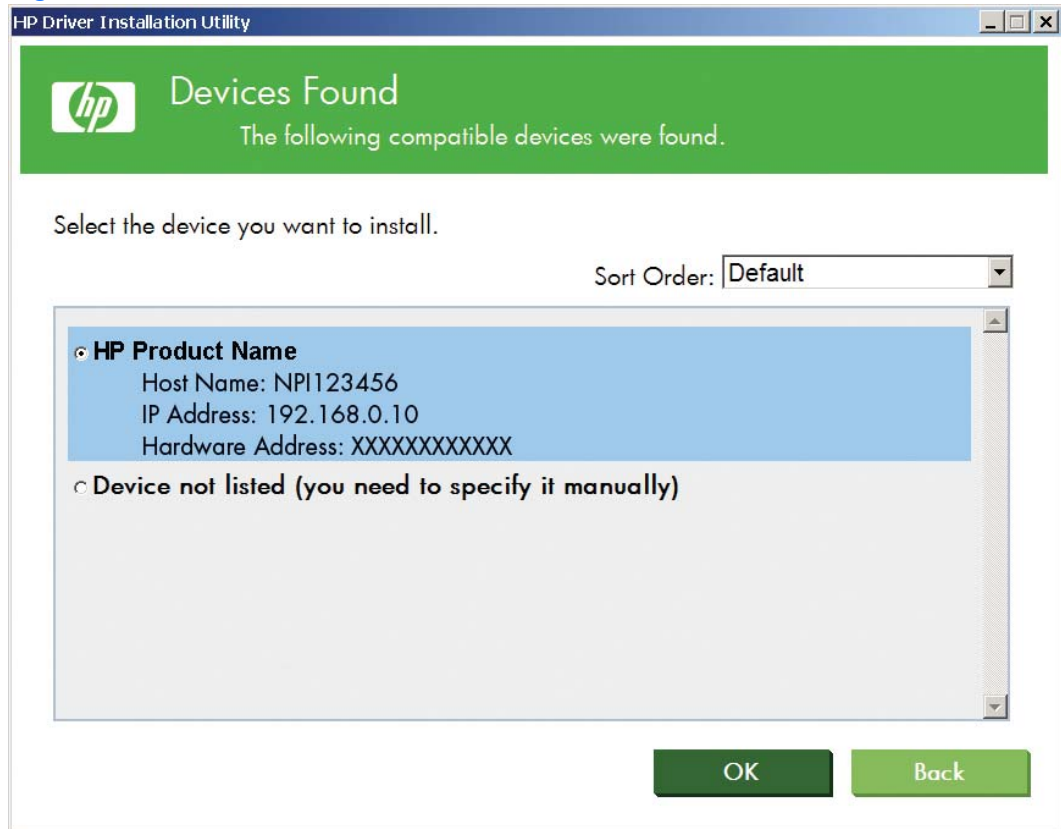

7. The network settings (Host Name, IP Address, and Hardware Address) for the product are displayed. Click the **Install** button. Once the software is installed, you will continue to the **Driver Installation Complete** screen.

Figure 3-21 Software Installation — Device Connection screen 2

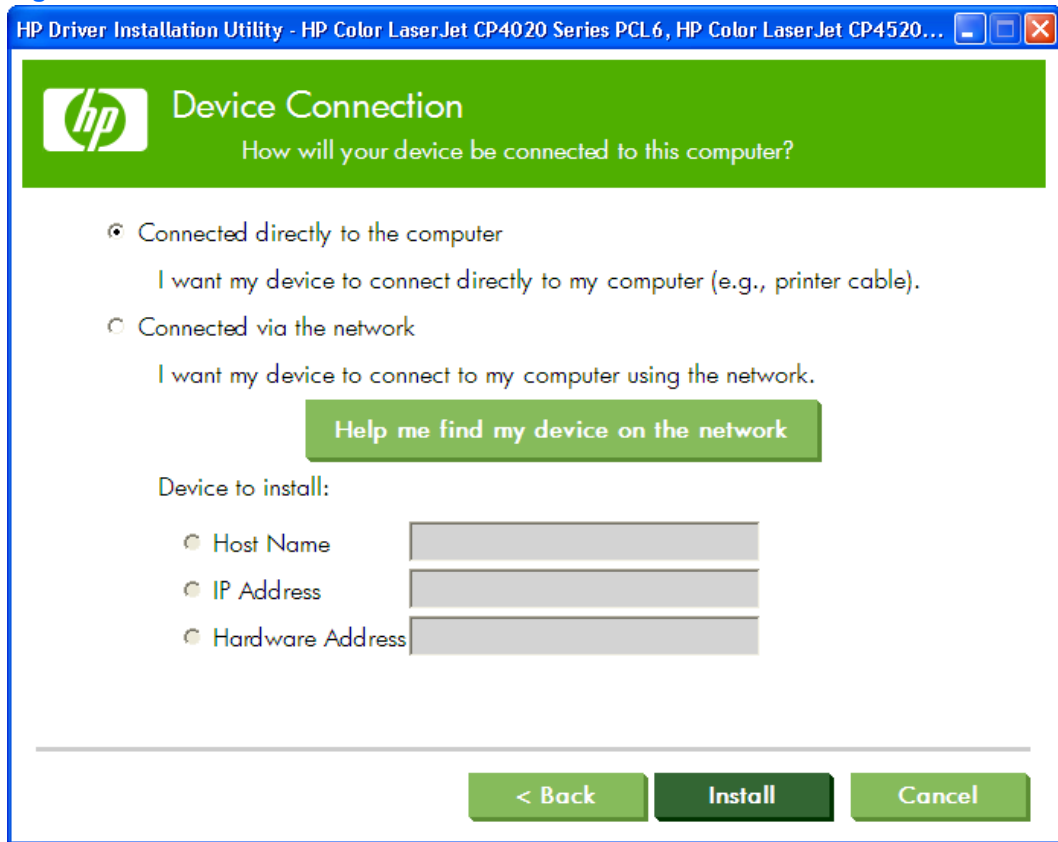

8. If you selected the **Connected directly to the computer** installation method, the following screen will appear at the conclusion of the software installation:

Figure 3-22 Software Installation — Driver Installation Complete screen 1

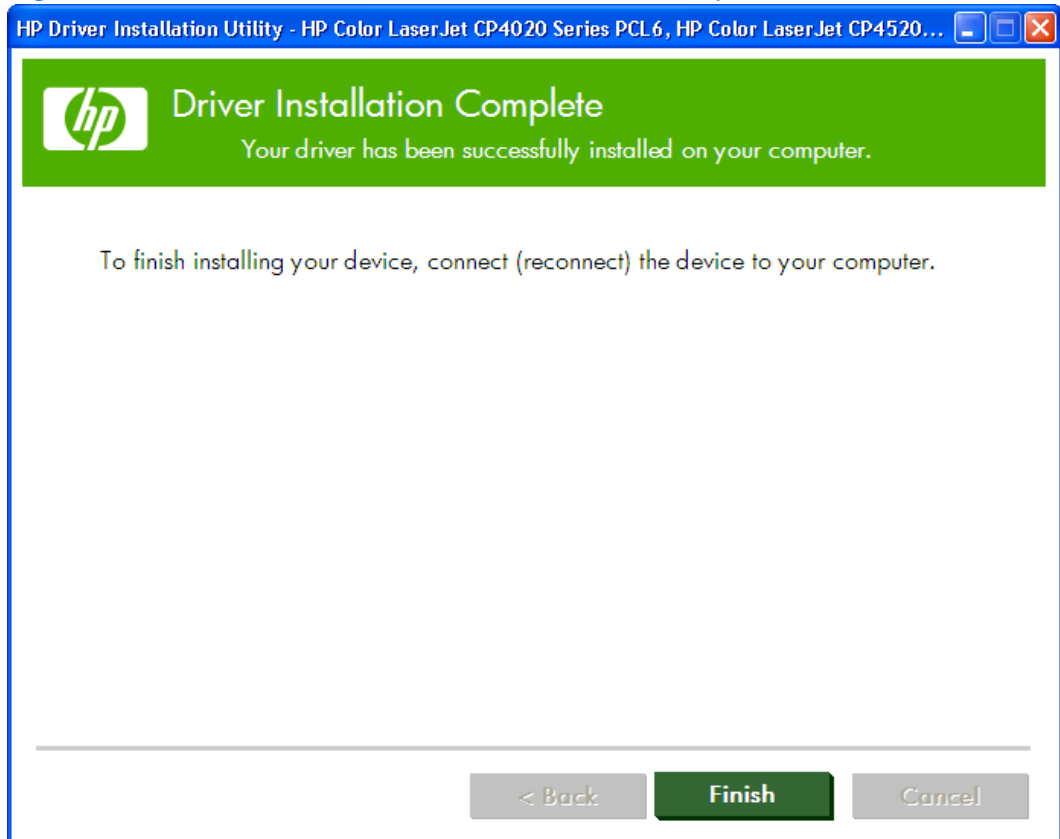

9. If you selected the **Connected via the network** installation method, the following screen will appear at the conclusion of the software installation:

Figure 3-23 Software Installation — Driver Installation Complete screen 2

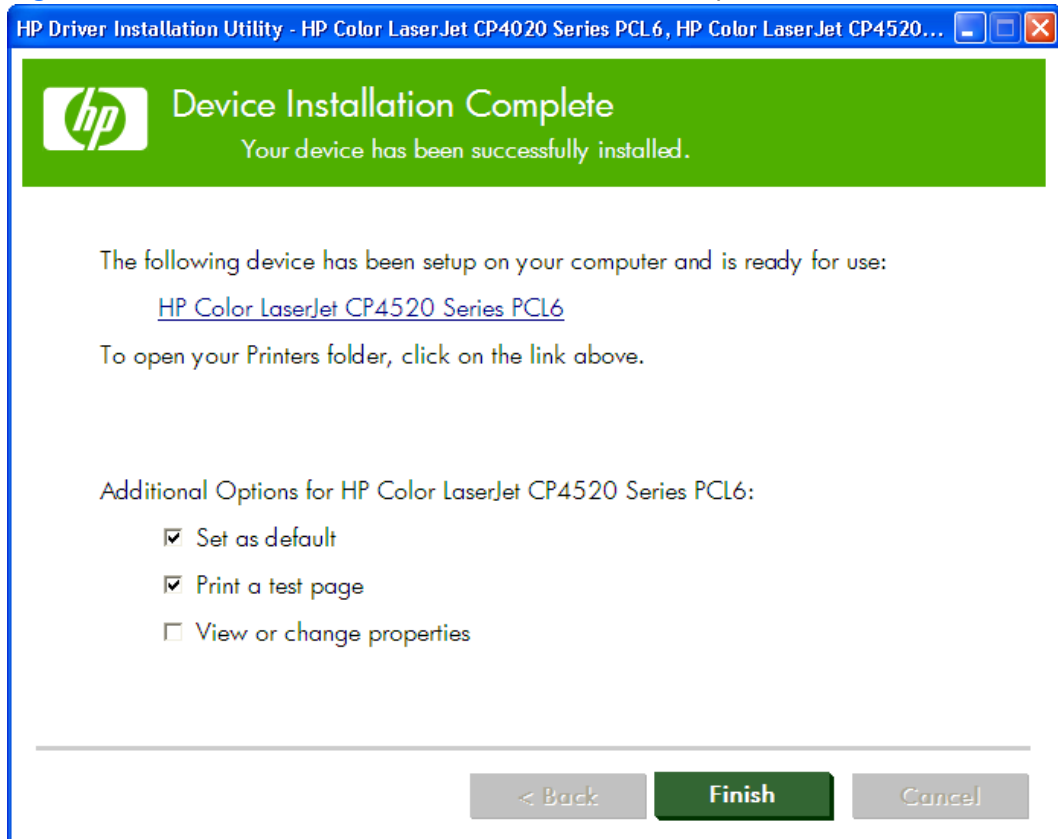

Point and Print installation for Windows

The following information helps you install a print driver by using the Microsoft Point and Print function when you cannot see the product on the network.

Point and Print is a Microsoft term that describes a two-step driver installation process:

1. Install a shared driver on a network print server.
2. "Point" to the print server from a network client so that the client can use the print driver.

Hewlett-Packard provides drivers that are compatible with the Point and Print feature, but this is a function of the Microsoft operating systems, not of HP print drivers. Windows XP, Windows Server 2003, Windows Server 2008, Windows Vista, and Windows 7 drivers from HP are supported only on Intel x86 processor types.

In a homogenous operating system environment (clients and servers running the same operating system), the same print-driver version that is vended from the server to the clients in a Point and Print environment also runs and controls the print queue configuration on the server.

However, in a mixed operating system environment (servers and clients running different operating systems), conflicts can occur when client computers run a version of the print driver that is different from the one on the print server.

In an effort to increase operating system stability, Microsoft determined that in Windows 2000 and all future operating systems, print drivers would run as *user-mode* processes. User-mode drivers run in a protected part of the operating system, as do all of the normal end-user processes and software programs. A user-mode print driver that functions incorrectly can terminate (or “crash”) only the process in which it is running—not the whole operating system. Because access to critical system resources is restricted, overall operating system stability is increased.

Detailed Microsoft Windows installation instructions

The dialog boxes shown here appear in the Windows XP Professional installation sequence. The order and appearance of dialog boxes can vary among operating systems.

Perform the recommended print driver installation using the HP Driver Installation Utility (HPDIU)

The recommended installation (**Install Now**) installs the PCL 6 print driver, screen fonts, and user guide. For information about how to perform an advanced (customized) installation, see [Performing an advanced print driver installation using the HP Driver Installation Utility \(HPDIU\) on page 87](#).

A series of dialog boxes appear during installation of the HP Color LaserJet Enterprise CP4020-CP4520 Series printing-system software in Windows environments.

 **NOTE:** You can return to the previous dialog box by clicking the **Back** button, or exit the HP Color LaserJet Enterprise CP4020-CP4520 Series printing-system software installation by clicking the **Cancel** button.

1. Close all programs.
2. Insert the HP Color LaserJet CP4525 printing system software CD into the CD-ROM drive. The software installer detects the language of the operating system, and then displays the main menu of the CD Browser program in the same language.

If the installer program has not started after 30 seconds, complete these steps:

- a. On the **Start** menu, click the **Run** option.
- b. Type the following: X:\SETUP.EXE (where X is the letter of the CD-ROM drive).
- c. Click the **OK** button.

3. Click the **Install Now** button to begin the installation process.

Figure 3-24 Software Installation — Initial screen

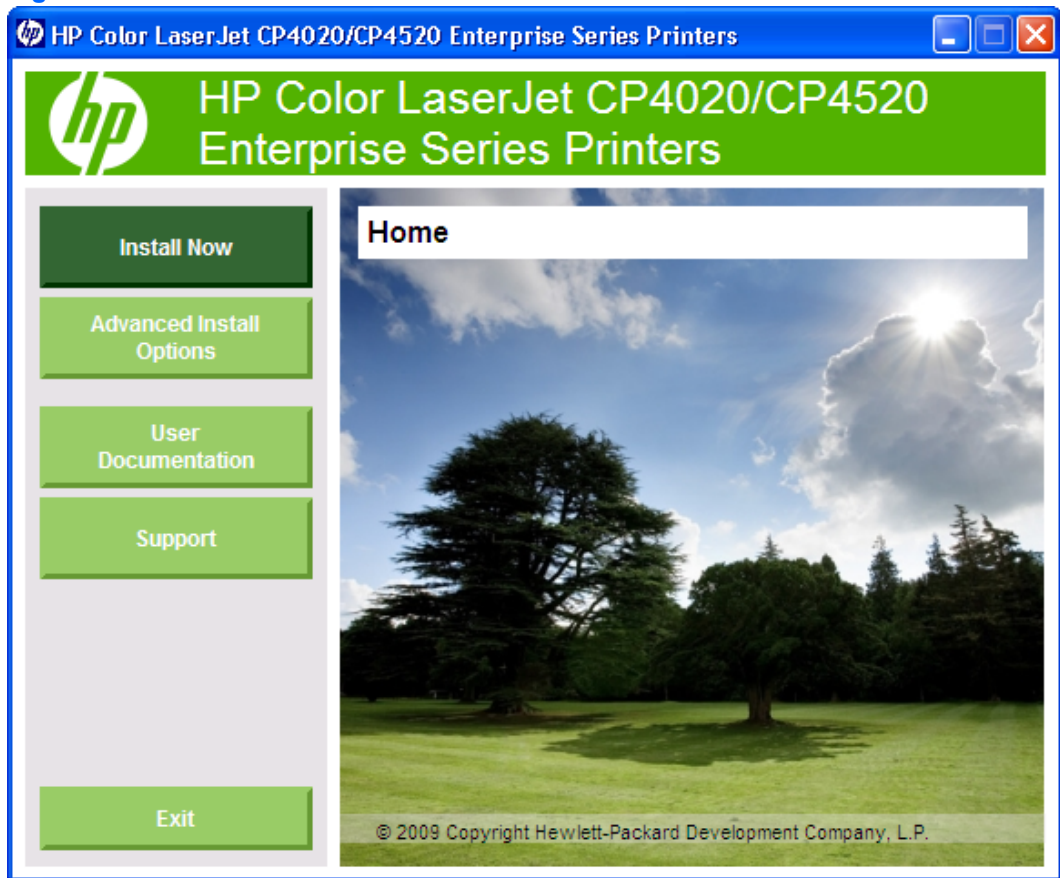

4. After reading the license agreement, click the **Accept** button to continue to the Device Connection screen.

Figure 3-25 Software Installation — License Agreement screen

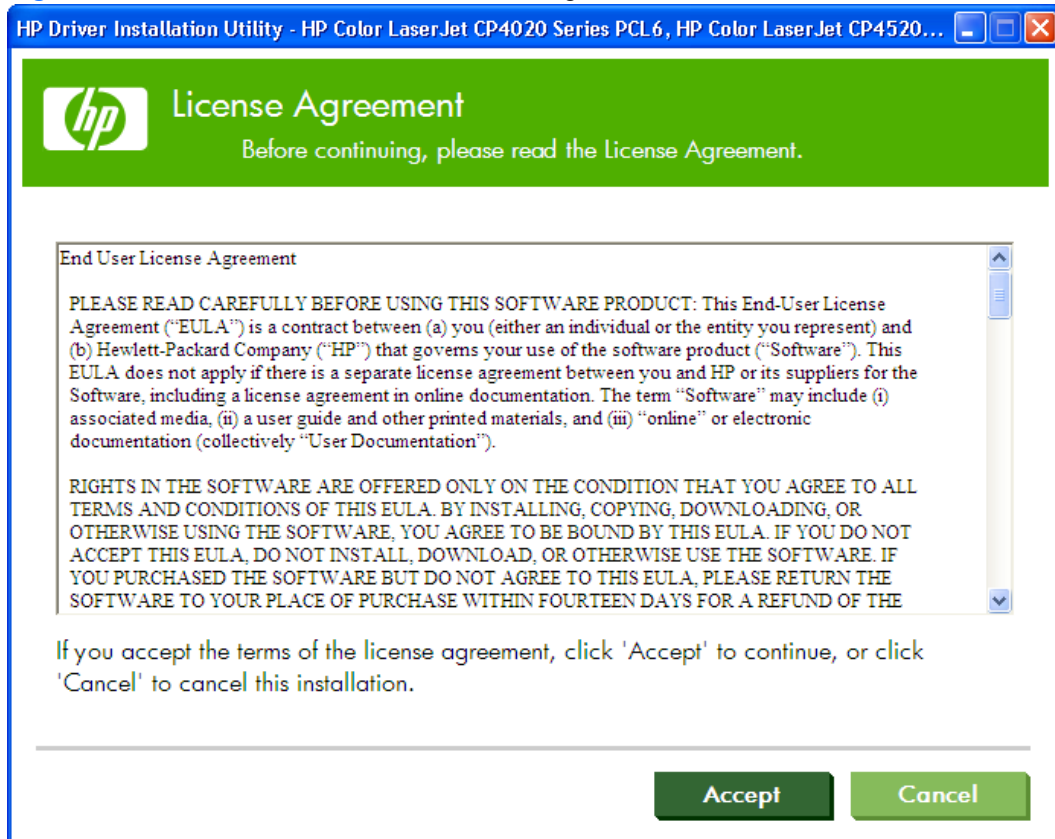

5. Select an option based on how the product will be connected to the computer.

Figure 3-26 Software Installation — Device Connection screen

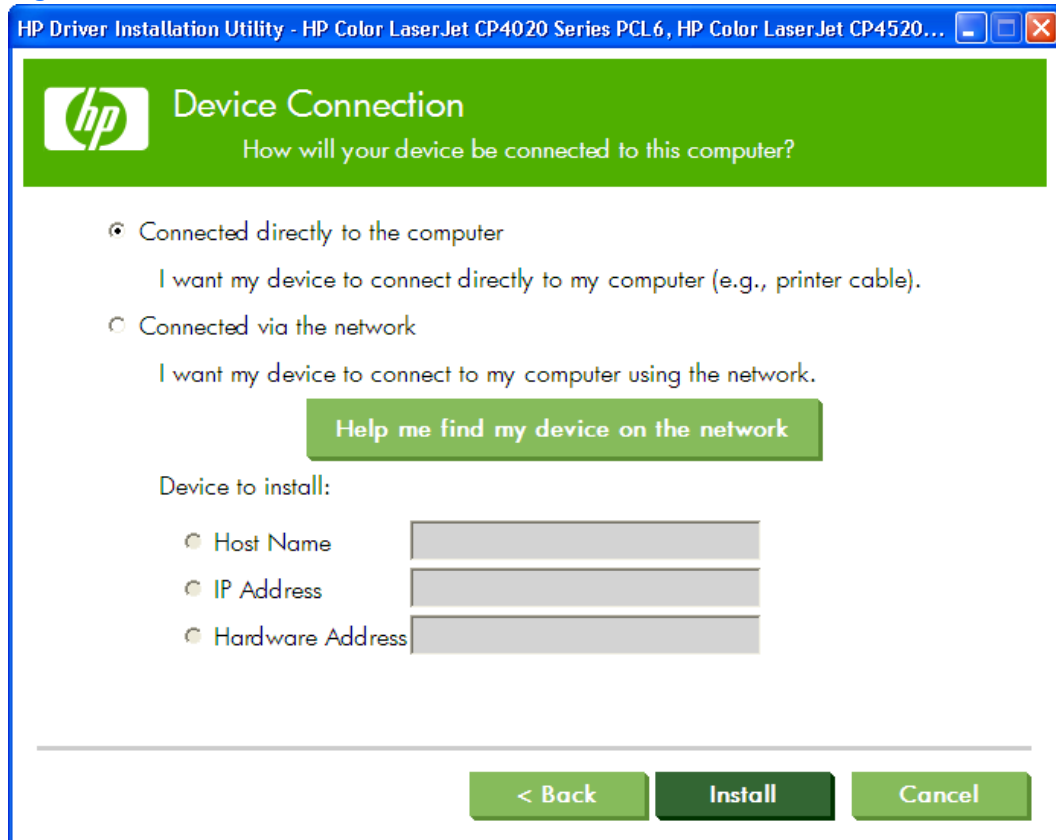

- **Connected directly to the computer:** Select this option and then click the **Install** button if the product will be connected to the computer using a USB cable. Once the software is installed, the **Driver Installation Complete** screen appears.

 **NOTE:** If you choose this option, the printer should not be connected to the computer until prompted during the installation process.

-or-

- **Connected via the network:** Select this option if the product will be connected to the computer using a network cable.
 - If the product's networking settings are known, you can enter either the Host Name, IP Address, or the Hardware Address, and then click the **Install** button. Once the software is installed, the **Driver Installation Complete** screen appears.
 - If the product's network settings are not known, click the **Help me find my device on the network** button. A **Discovery in Progress** window appears. After the computer searches the network, the **Devices Found** screen appears.

6. A list of products is displayed. Select the product you want to install and then click the **OK** button to continue to the **Device Connection** screen.

Figure 3-27 Software Installation — Devices Found screen

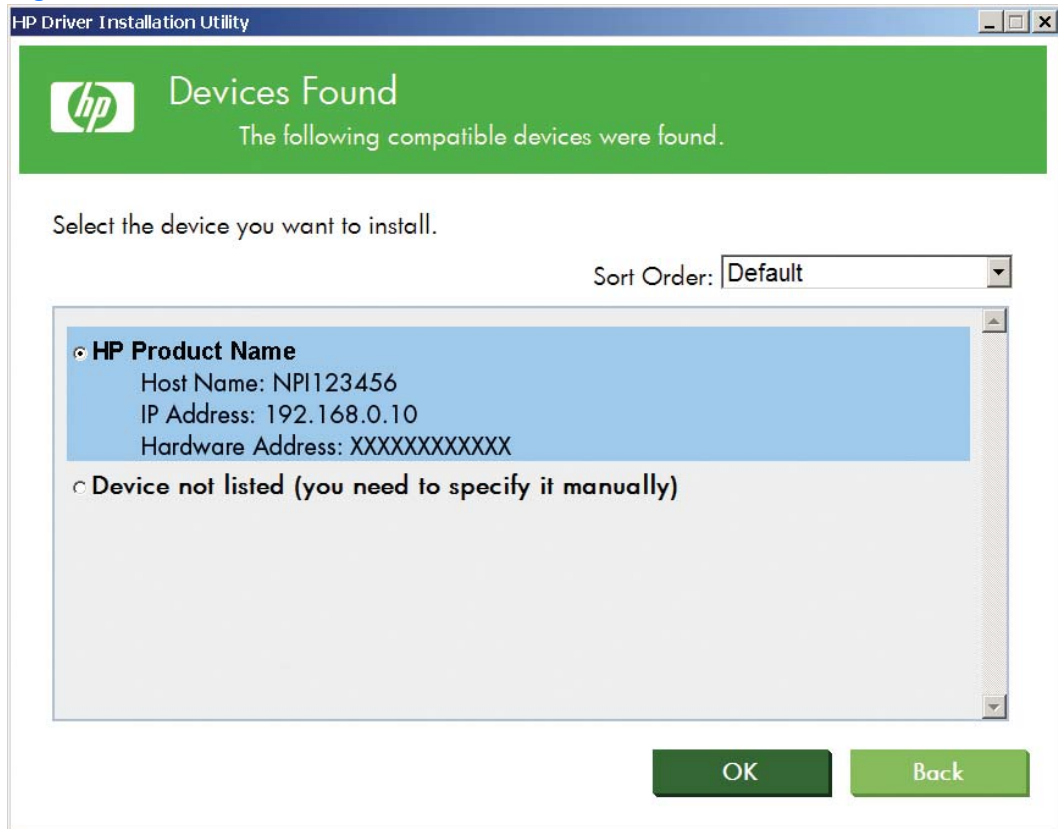

7. The network settings (Host Name, IP Address, and Hardware Address) for the product are displayed. Click the **Install** button. Once the software is installed, you will continue to the **Driver Installation Complete** screen.

Figure 3-28 Software Installation — Device Connection screen 2

HP Driver Installation Utility

Device Connection

How will your device be connected to this computer?

Connected directly to the computer
I want my device to connect directly to my computer (e.g., printer cable).

Connected via the network
I want my device to connect to my computer using the network.

[Help me find my device on the network](#)

Device to install:

Host Name

IP Address

Hardware Address

[< Back](#) [Install](#) [Cancel](#)

8. Depending on the installation method, one of the following dialog boxes appears at the conclusion of the software installation:
 - If you selected the **Connected directly to the computer** installation method, the following screen appears once the software is installed. Click the **Finish** button to complete the installation.

Figure 3-29 Software Installation — Driver Installation Complete screen 1

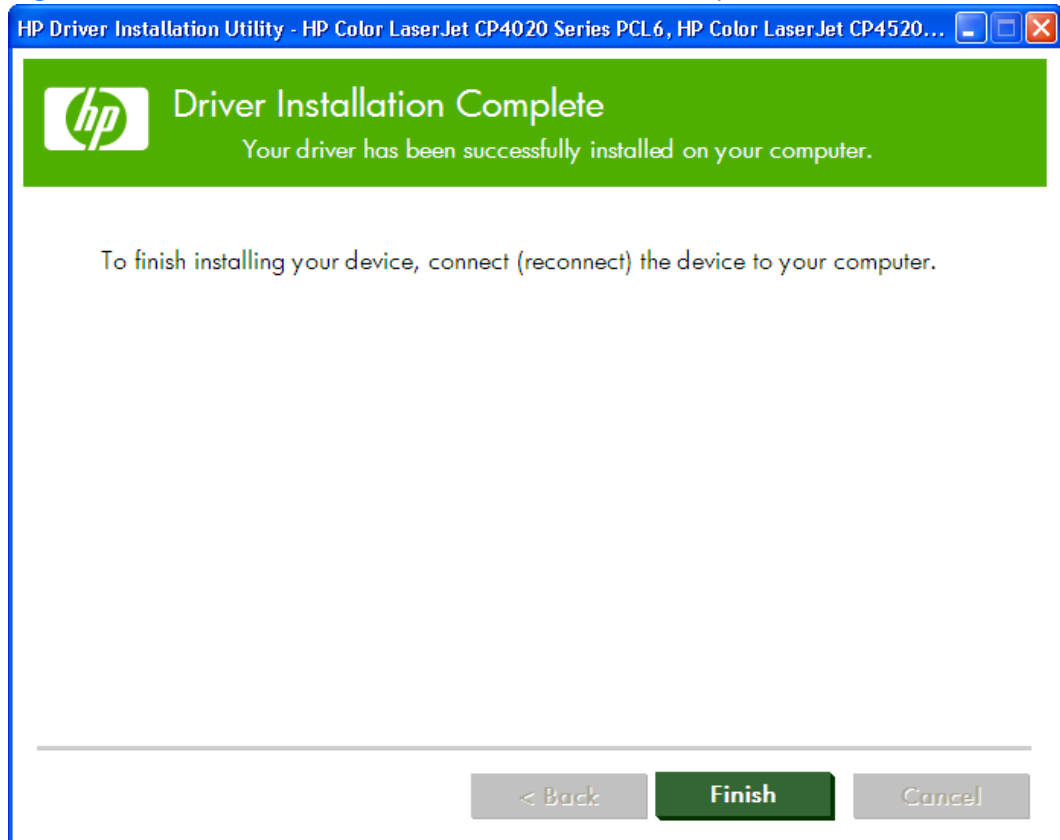

- If you selected the **Connected via the network** installation method, the following screen appears once the software is installed. You can make this your default product by selecting the **Set as default** check box, send a test page to the product by selecting the **Print a test page** check box, or gain access to the print driver by selecting the **View or change properties** check box.

Click the **Finish** button to complete the installation.

Figure 3-30 Software Installation — Driver Installation Complete screen 2

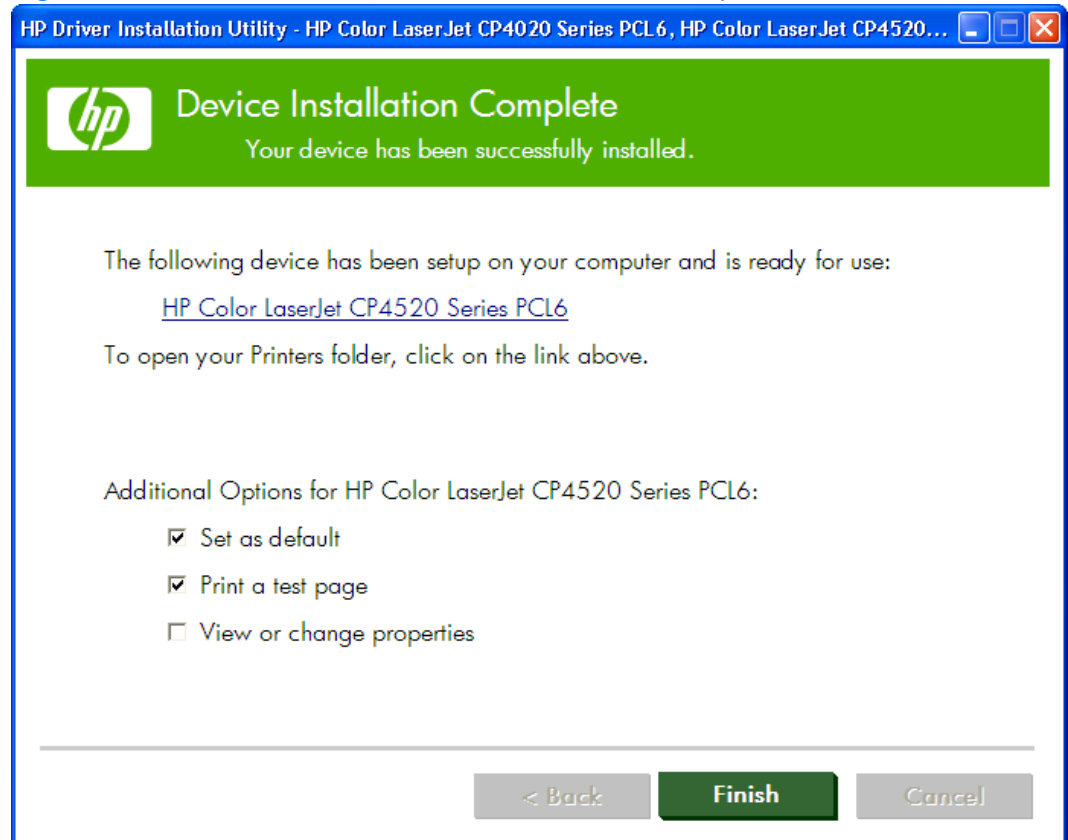

When you are finished with the installation, the Additional Options screen appears.

Figure 3-31 Additional Options



Use the options available on this screen to install HP Update and marketing resources software, check online for product-specific merchandise, and register your product using Web Registration.

Use the Back, Next, Finish, and Cancel buttons

The following buttons appear on various dialog boxes during the installation process.

- **Back.** Click this button to return to the previous dialog box.
- **Next.** After you select any options on a given screen, click this button to proceed to the next step in the installation sequence.
- **Finish.** Click this button to complete the installation process and proceed to the **Additional Options** screen.

- **Cancel.** Click this button to exit the installer without installing the product. When you click **Cancel**, the **Installation Cancelled** dialog box opens, stating that the installation was cancelled.

Figure 3-32 Installation Cancelled dialog box

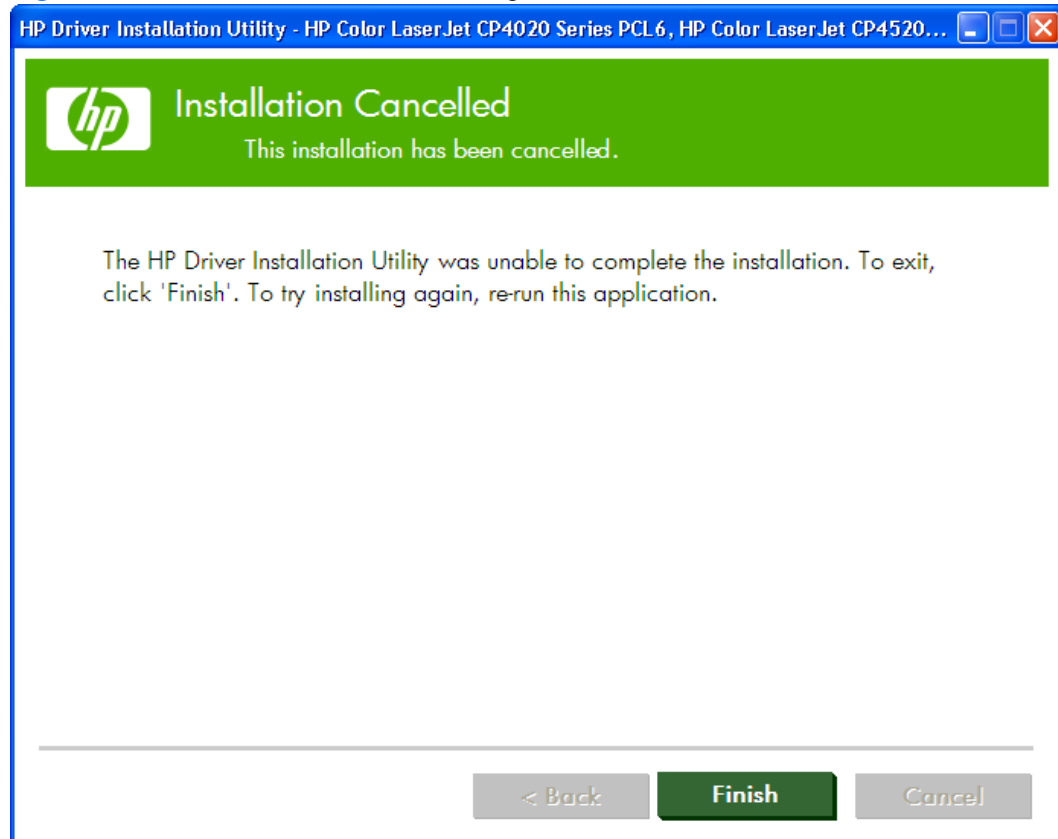

Click **Finish** to close the installer.

Performing an advanced print driver installation using the HP Driver Installation Utility (HPDIU)

The advanced installation enables you to select the print drivers and software that you want to install.

A series of dialog boxes appear during installation of the HP Color LaserJet Enterprise CP4020-CP4520 Series printing-system software in Windows environments.

NOTE: You can return to the previous dialog box by clicking the **Back** button, or exit the HP Color LaserJet Enterprise CP4020-CP4520 Series printing-system software installation by clicking the **Cancel** button.

1. Close all programs.
2. Insert the HP Color LaserJet CP4525 printing system software CD into the CD-ROM drive. The software installer detects the language of the operating system, and then displays the main menu of the CD Browser program in the same language.

If the installer program has not started after 30 seconds, complete these steps:

- a. On the **Start** menu, click the **Run** option.
- b. Type the following: X:\SETUP.EXE (where X is the letter of the CD-ROM drive).

- c. Click the **OK** button.

This screen appears when the HP Color LaserJet Enterprise CP4020-CP4520 Series software CD is inserted into the CD-ROM drive.

Figure 3-33 Software Installation — Initial screen



3. Click the **Advanced Install Options** button to view the **Advanced Install Options** screen.

Figure 3-34 Software Installation — Advanced Installation Options screen



4. Click the button for the print driver that you want to install. This starts the installation process or takes you to the Web where you can download and install your preferred driver.

5. After reading the license agreement, click the **Accept** button to continue to the **Device Connection** screen.

Figure 3-35 Software Installation — License Agreement screen

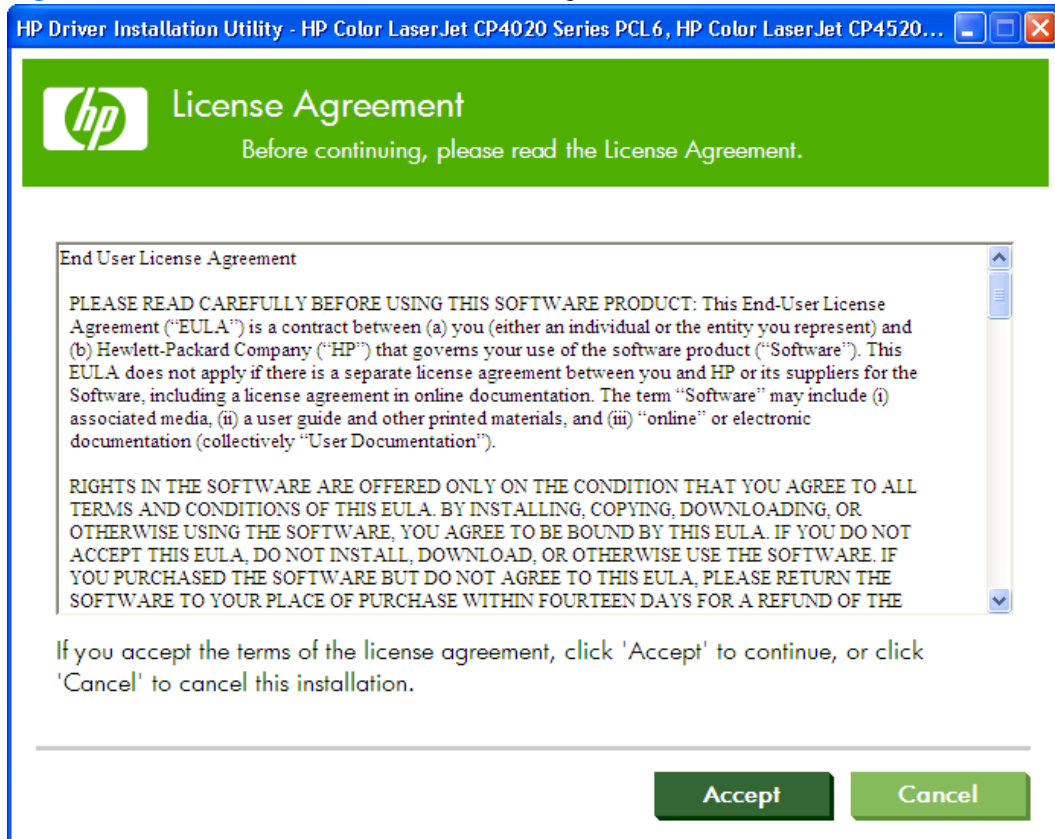

6. Select an option based on how the product will be connected to the computer.

Figure 3-36 Software Installation — Device Connection screen

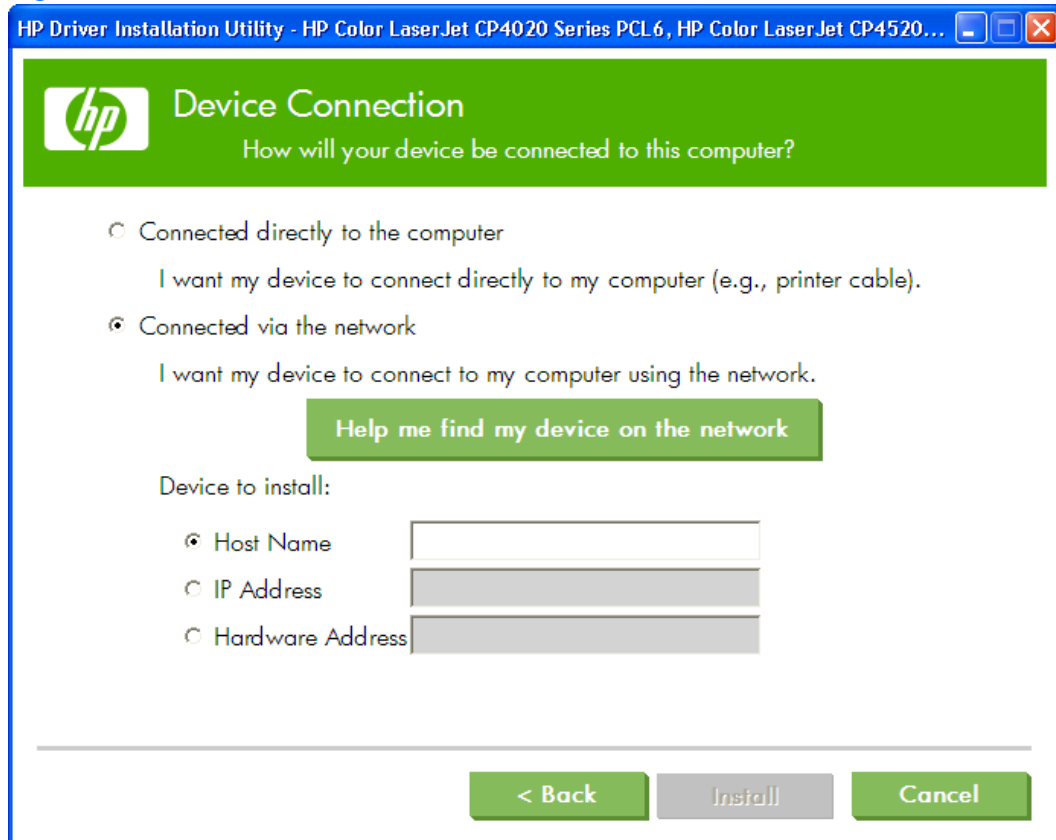

- **Connected directly to the computer:** Select this option and then click the **Install** button if the product will be connected to the computer using a USB cable. Once the software is installed, the **Driver Installation Complete** screen appears.

 **NOTE:** If you choose this option, the printer should not be connected to the computer until prompted during the installation process.

-or-

- **Connected via the network:** Select this option if the product will be connected to the computer using a network cable.
 - If the product's networking settings are known, you can enter either the **Host Name**, **IP Address**, or the **Hardware Address**, and then click the **Install** button. Once the software is installed, the **Driver Installation Complete** screen appears.
 - If the product's network settings are not known, click the **Help me find my device on the network** button. A **Discovery in Progress** window appears. After the computer searches the network, the **Devices Found** screen appears.

7. A list of products is displayed. Select the product you want to install and then click the **OK** button to continue to the **Device Connection** screen.

Figure 3-37 Software Installation — Devices Found

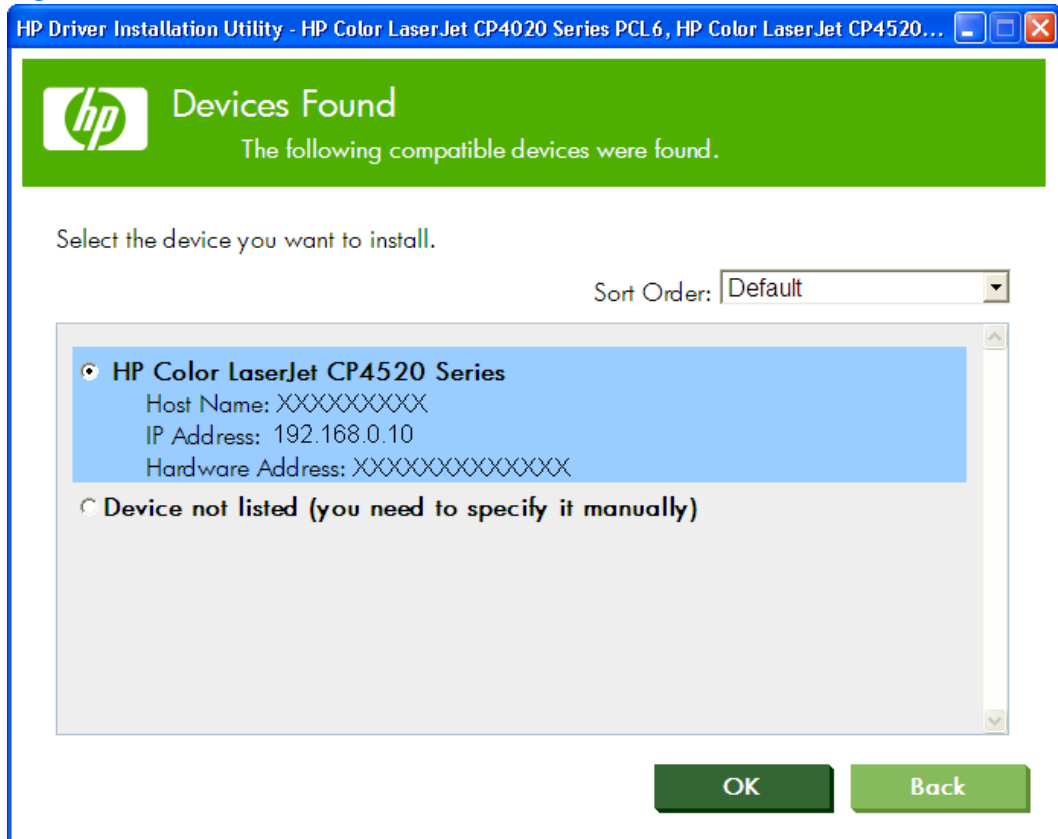

8. The network settings (Host Name, IP Address, and Hardware Address) for the product are displayed. Click the **Install** button. Once the software is installed, you will continue to the **Driver Installation Complete** screen.

Figure 3-38 Software Installation — Device Connection screen 2

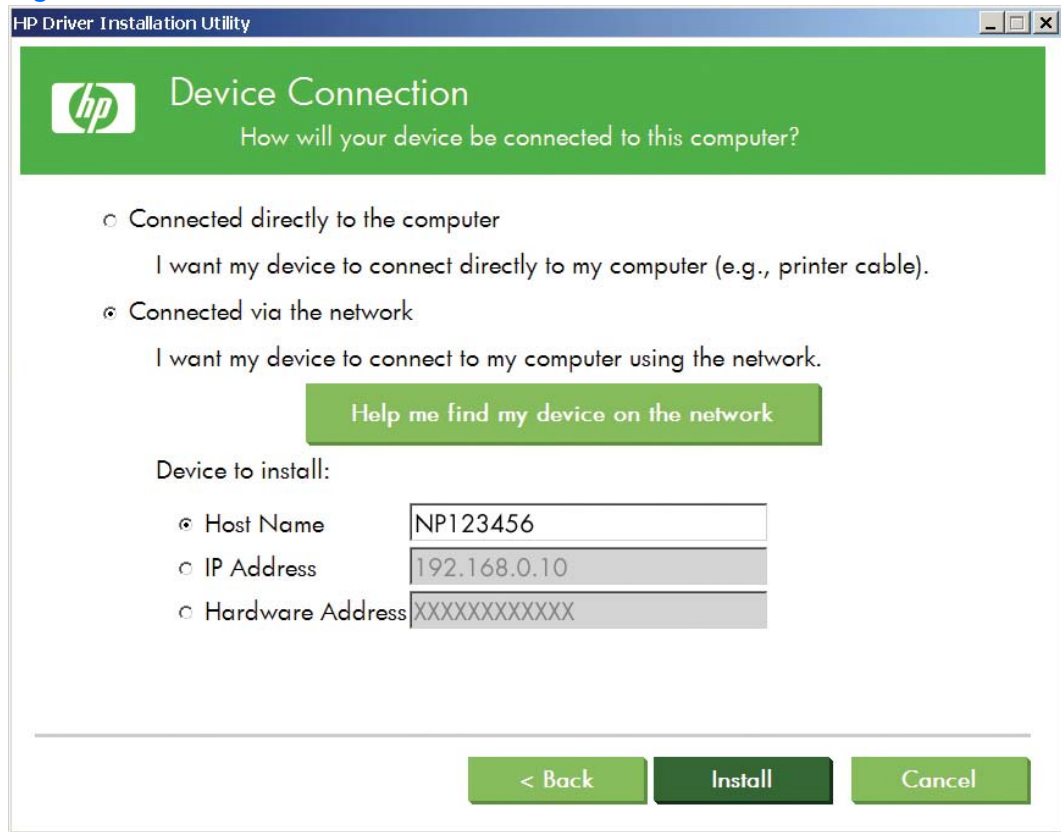

9. Depending on the installation method, one of the following dialog boxes appears at the conclusion of the software installation:
 - If you selected the **Connected directly to the computer** installation method, the following screen appears once the software is installed. Click the **Finish** button to complete the installation.

Figure 3-39 Software Installation — Driver Installation Complete screen

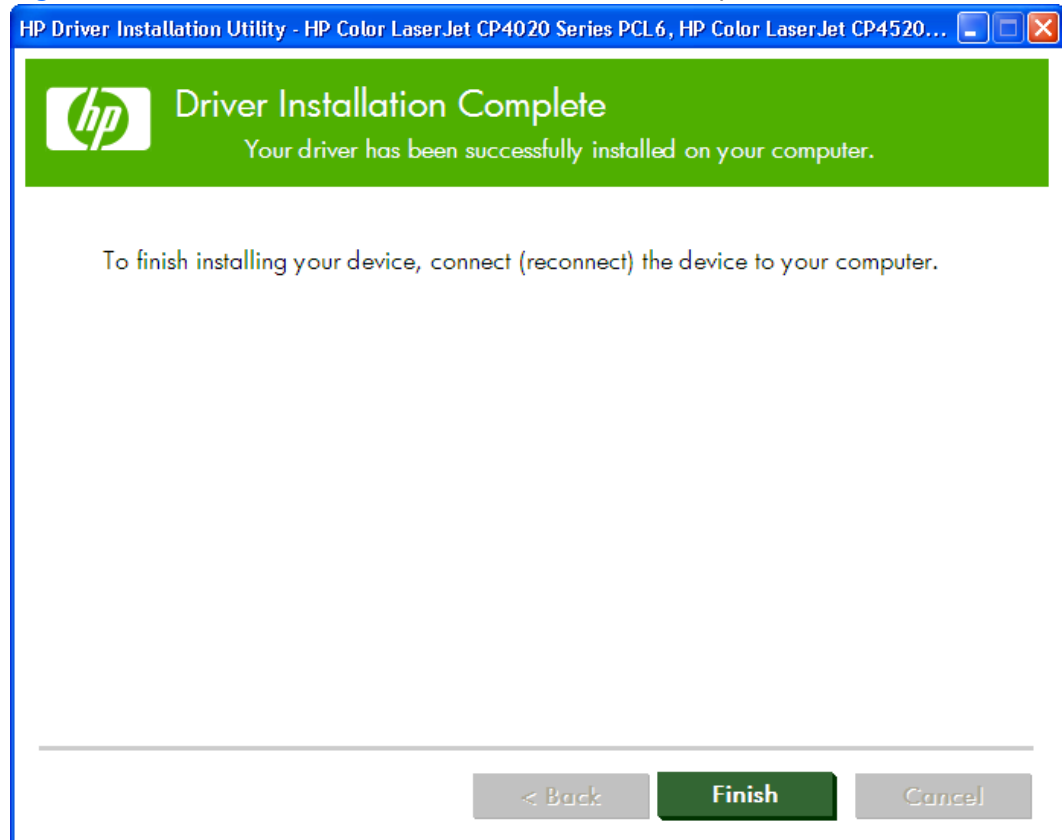

- If you selected the **Connected via the network** installation method, the following screen appears once the software is installed. You can make this your default product by selecting the **Set as default** check box, send a test page to the product by selecting the **Print a test page** check box, or gaining access to the print driver by selecting the **View or change properties** check box.

Click the **Finish** button to complete the installation.

Figure 3-40 Software Installation — Driver Installation Complete screen 2

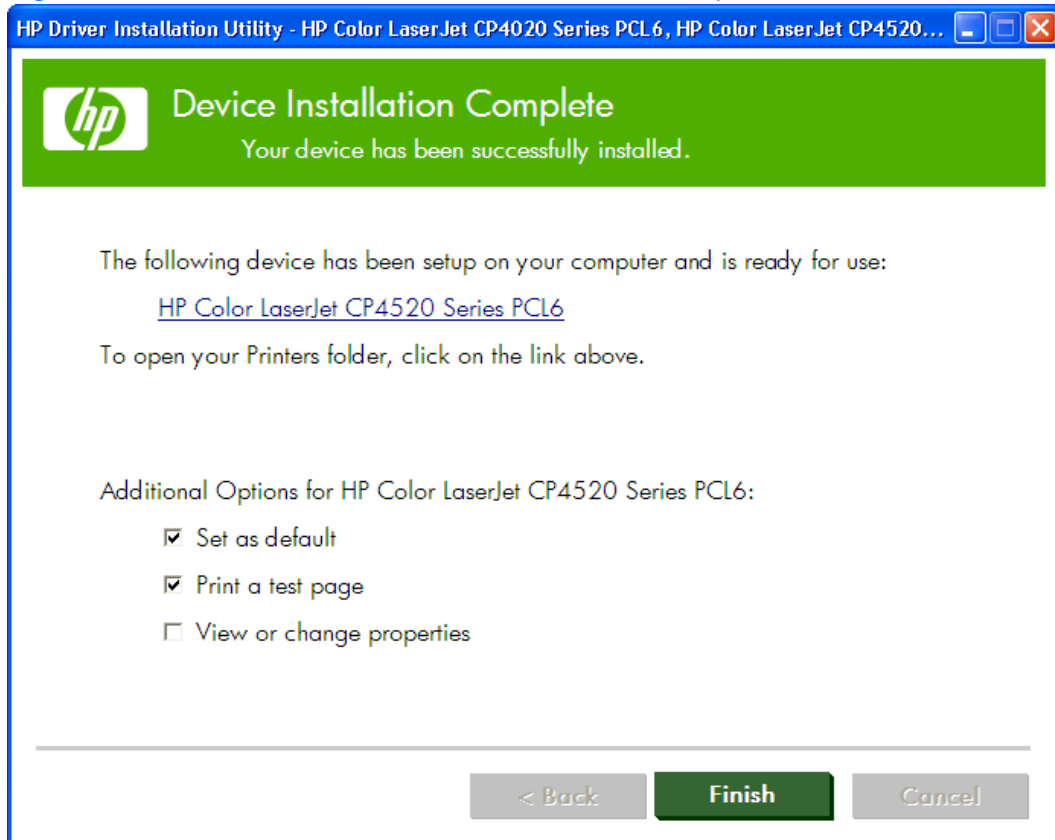

When the installation is complete, the **Additional Options** screen appears.

You can click on any of the **Additional Options** buttons, return to the **Home** screen, or exit the HPDIU.

Figure 3-41 Software Installation — Additional Options screen



Use the options available on this screen to install HP Update and marketing resources software, check online for product-specific merchandise, and register your product using Web Registration.

Set a default printer

1. In Windows Vista and Windows 7, click the **Start** button, click **Control Panel**, and then click **Hardware and Sound**. Under the **Printers** section, click **Change default printer**.

In Windows XP, Windows Server 2003, and Windows Server 2008, click **Start**, click **Control Panel**, and then click **Printers and Faxes** (Windows XP Professional) or **Printers and other hardware devices** (Windows XP Home).
2. Right-click the product that you want to set as the default printer.
3. Click **Set As Default**. A check mark appears next to the product set as the default.

Uninstall instructions

Use these instructions to uninstall the product using the Windows Add or Remove Programs feature.

 **NOTE:** You must have Administrator privileges to uninstall the product using Add or Remove Programs.

1. In Windows Vista and Windows 7, click the **Start** button, click **Control Panel**, and then click **Add or Remove Programs**.

In Windows XP, Windows Server 2003, and Windows Server 2008, click **Start**, click **Control Panel**, and then double-click **Add or Remove Programs**.

2. Click the entry for the HP Color LaserJet Enterprise CP4020-CP4520 Series product, and then click **Remove**. The following screen appears.

Figure 3-42 Uninstall

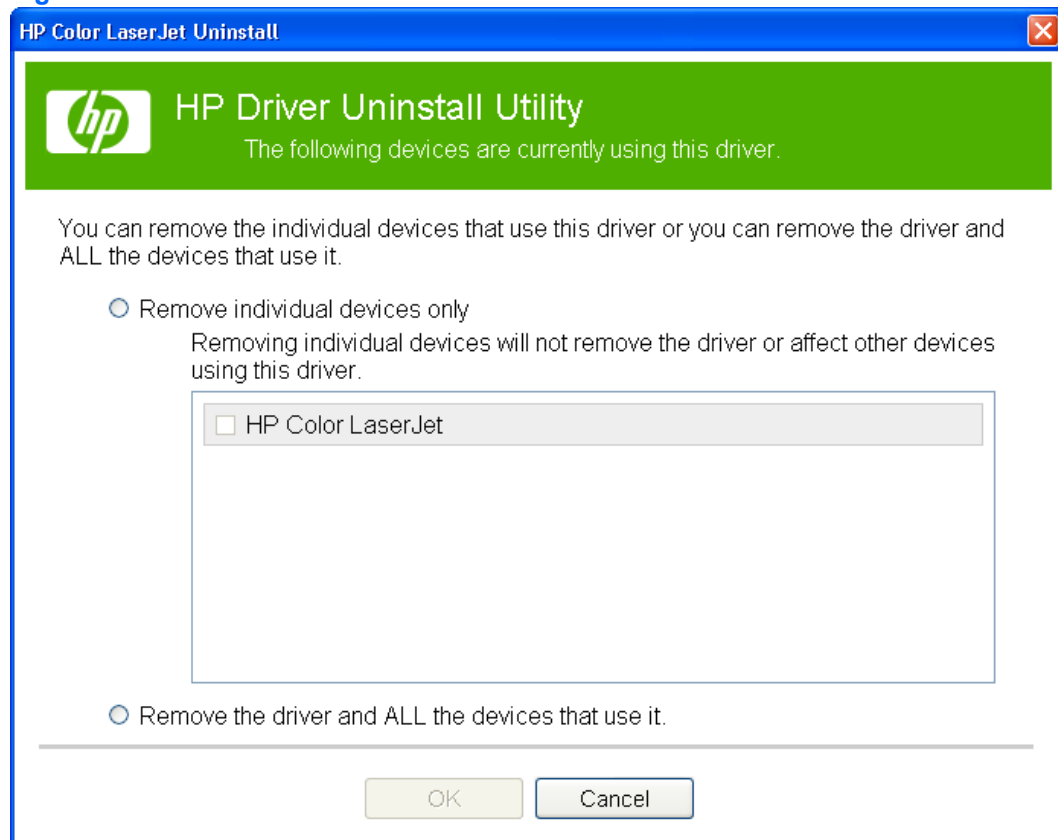

Select the uninstall option that you want to perform, and then click **OK** to initiate the uninstall process.

4 HP PCL 6 print driver and HP PS Universal Print Driver for Windows

Introduction

This chapter describes the features of the HP Color LaserJet Enterprise CP4020-CP4520 Series PCL 6 Print Driver for, Windows XP (32-bit and 64-bit), Windows Server 2003 (32-bit and 64-bit), Windows Server 2008 (32-bit and 64-bit), Windows Vista (32-bit and 64-bit), and Windows 7 (32-bit and 64-bit).

You can control print jobs from several places:

- the product control panel
- the software program print dialog box
- the driver user interface

Generally, for features that are duplicated in more than one location (for instance, you can select the paper input tray from any of them), settings that are established in the software program take precedence over print-driver settings. Print-driver settings, in turn, override product control-panel settings.

When you install the printing-system software in Windows, the HP PCL 6 Print Driver is installed by default through the installer. The HP PS Universal Print Driver and the HP PCL 5 Universal Print Driver can be installed by downloading the software from the Web.

Topics:

- [Change printer-driver settings for Windows](#)
- [Access print drivers](#)
- [Help system](#)
- [Advanced tab features](#)
- [Printing Shortcuts tab features](#)
- [Paper/Quality tab features](#)
- [Effects tab features](#)
- [Finishing tab features](#)
- [Job Storage tab features](#)
- [Color tab features](#)
- [Services tab features](#)

- [Device Settings tab features](#)
- [About tab features](#)

Change printer-driver settings for Windows

Change the settings for all print jobs until the software program is closed

1. On the **File** menu in the software program, click **Print**.
2. Select the driver, and then click **Properties** or **Preferences**.

The steps can vary; this procedure is most common.

Change the default settings for all print jobs

1. **Windows XP, Windows Server 2003, and Windows Server 2008 (using the default Start menu view):** Click **Start**, and then click **Printers and Faxes**.

Windows XP, Windows Server 2003, and Windows Server 2008 (using the Classic Start menu view): Click **Start**, click **Settings**, and then click **Printers**.

Windows Vista: Click **Start**, click **Control Panel**, and then in the category for **Hardware and Sound** click **Printer**.

Windows 7: Click **Start**, and then click **Devices and Printers**.

2. Right-click the driver icon, and then select **Printing Preferences**.

Change the product configuration settings

1. **Windows XP, Windows Server 2003, and Windows Server 2008 (using the default Start menu view):** Click **Start**, and then click **Printers and Faxes**.

Windows XP, Windows Server 2003, and Windows Server 2008 (using the Classic Start menu view): Click **Start**, click **Settings**, and then click **Printers**.

Windows Vista: Click **Start**, click **Control Panel**, and then in the category for **Hardware and Sound** click **Printer**.

Windows 7: Click **Start**, and then click **Devices and Printers**.

2. Right-click the driver icon, and then select **Properties** or **Printer properties**.
3. Click the **Device Settings** tab.

Access print drivers

Depending on the operating system on which you are installing the print drivers, you can gain access to the print drivers and different print-driver interfaces in several ways.

To gain access to the print-driver settings from within most software programs, follow these steps:

1. Click **File**.
2. Click **Print**.
3. Click **Properties**.

The appearance and names of the driver tabs can vary, depending on the operating system. These driver settings apply only while that software program is open.

You can control the drivers directly from the Printers folder. Here you have access to two sets of driver tabs: the **Printing Preferences** tabs and the **Properties** tabs. The settings that you make on the **Printing Preferences** driver tabs control the driver default settings for each user's profile. Installable options can be configured in **Properties** driver tabs.

Printing Preferences driver tabs

The **Printing Preferences** driver tabs change the default settings that are used across all software programs. To gain access to these tabs, follow these steps:

1. In Windows Vista and Windows 7, click the **Start** button, click **Control Panel**, click **Hardware and Sound**, and then click **Printers**.

In Windows XP, Windows Server 2003, and Windows Server 2008, click **Start**, click **Settings**, and then click **Printers and Faxes**.
2. Right-click the product icon.
3. Click **Printing Preferences**.

The following **Printing Preferences** print-driver tabs are available:

- **Advanced**
- **Printing Shortcuts**
- **Paper/Quality**
- **Effects**
- **Finishing**
- **Job Storage**
- **Color**
- **Services**

Properties driver tabs

This set of tabs controls the driver behavior and driver connections. To gain access to the **Properties** tabs, follow these steps:

1. In Windows Vista and Windows 7, click the **Start** button, click **Control Panel**, click **Hardware and Sound**, and then click **Printers**.

In Windows XP, Windows Server 2003, and Windows Server 2008, click **Start**, click **Settings**, and then click **Printers and Faxes**.

2. Right-click the product icon.
3. Click **Properties**.

The following **Properties** print-driver tabs are available:

- **General**
- **Sharing**
- **Ports**
- **Advanced**
- **Color Management**
- **Security**
- **Device Settings**
- **About**

Help system

The HP PCL 6 Print Driver includes a full-featured Help system to provide assistance with printing and configuration options.

“What's this?” Help

Windows XP, Windows Server 2003, Windows Server 2008, Windows Vista, and Windows 7 support **What's this?** Help. You can gain access to What's this? Help messages in any of the following ways:

- Right-click a feature or control. A pop-up Help window appears.
- Click the ? button in the upper-right corner of the frame, next to the X, to change the cursor to an arrow with a question mark. When you use this special cursor to select a control, the pop-up Help window for that feature appears.
- Click a feature or control, and then press the F1 key. The Help window for the currently selected control appears.

Incompatible Print Settings messages

Incompatible Print Settings (constraint) messages are unsolicited messages that appear in response to specific print-driver selections. These messages alert you to selections that are illogical or impossible given the product capabilities or the current settings of other controls.

 **NOTE:** Constraint messages are limited, and the underlying software architecture might accept some settings that are illogical or impossible for the product to perform. Sending a job with incompatible settings can lead to unexpected results. If print jobs do not print as expected, check the product documentation for the product capabilities.

In supported Windows operating environments, some technically invalid print-driver configurations result in warning messages. Duplexing, for example, is not possible when the Transparency paper type is selected. The following figure shows an **Incompatible Print Settings** message.

Figure 4-1 An **Incompatible Print Settings** message

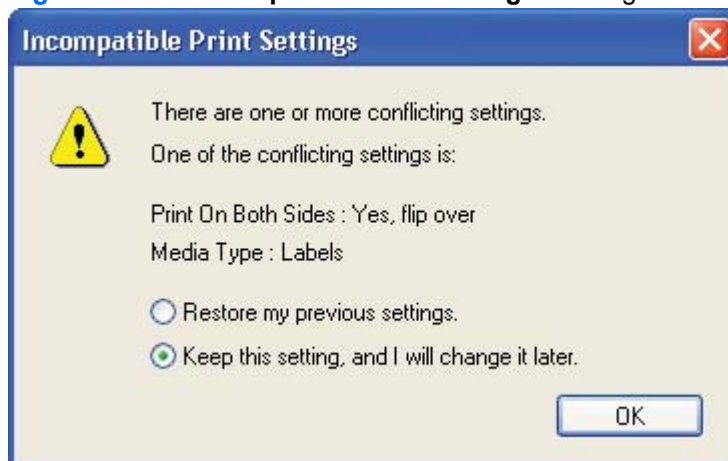

To resolve the conflicting settings, click **Restore my previous settings.**, and then click **OK**. The driver resets the conflicting control back to its previous state.

If you want to keep the conflicting setting, click **Keep this setting, and I will change it later.**, and then click **OK**.

 **NOTE:** In this example, the conflict can be resolved manually. If the conflict is not resolved when the driver is closed, then the same dialog appears again when a print job is sent to the product.

Advanced tab features

 **NOTE:** The **Advanced** tab is located on the **Printing Preferences** tab set. For information about how to access these tabs, see [Printing Preferences driver tabs on page 101](#),

Use the **Advanced** tab to change the layout of printed pages. Use this tab to configure special controls that are not commonly used, as well as to control features such as collating and copies in the driver (although most current software programs support these features in the print dialog box or through the page settings in the software program). The following figure shows the **Advanced** tab.

Figure 4-2 The default appearance of the **Advanced** tab

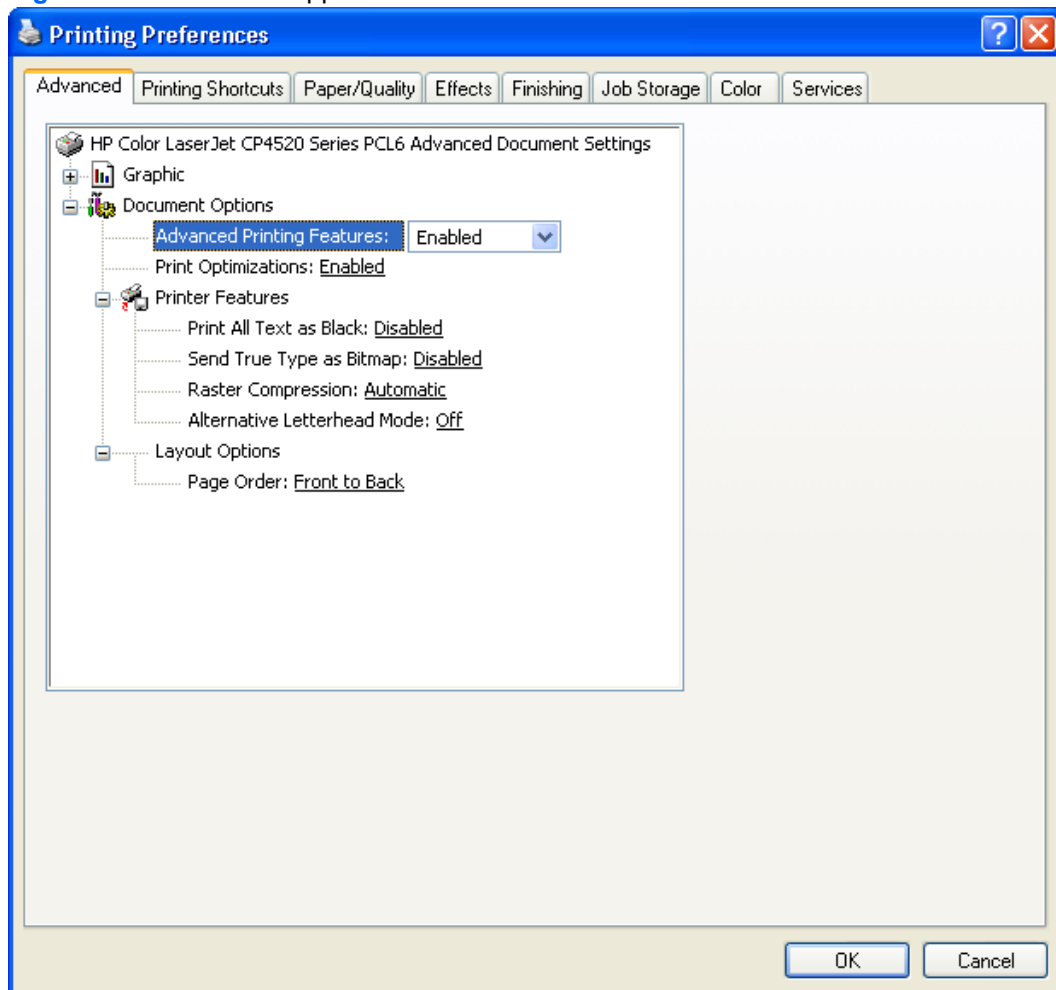

The **Advanced** tab contains the following controls:

- [Paper/Output](#)
- [Graphic](#)
- [Document Options](#)

Paper/Output

The **Paper/Output** setting contains the **Copy Count** setting.

Copy Count

Copy Count specifies the number of copies to print. This driver setting is useful for software programs that do not provide a copy count. If a copy count is available in the software program, set the copy count in the software program.

The number of copies that you request appears in the **Copy Count** option. You can select the number by typing in the text box or by using the up and down arrows to the right of the text box. Valid entries are numbers from 1 to 9999. The copies value will not advance from the maximum number (9999) to 1 when the up arrow is used, or change from 1 to the maximum number (9999) when the down arrow is used. When you click another group box or leave the **Advanced** tab, invalid entries into the text box (such as non-numerical input, numbers less than 1, or numbers greater than the maximum allowed) are changed to the last valid value that appeared in the text box. The default number of copies is 1.

Because you can set the number of copies that you want from some software programs, conflicts between the software program you are using and the driver can arise. In most cases, the software program and the driver communicate, so that the number of copies set in one location (such as the program) will appear in the other (such as the driver). For some programs, this communication does not take place, and the copies values are treated independently. For these programs, setting 10 copies in the program and then setting 10 copies in the driver will result in 100 copies (10 x 10) being printed. It is recommended that you set the number of copies in the program, whenever possible.

When the **Copy Count** option is set to more than 1, the **Collated** check box becomes available. Select this check box when you want the product to collate the printed copies. Most current software programs support the collating feature in the print dialog box or through the page settings in the software program.

Graphic

The **Graphic** setting contains the following controls:

- **Image Color Management** settings
- **True Type Font** settings

Image Color Management

This control lists the available Image Color Management (ICM) options used for printing color graphics. ICM, a set of calculations for color matching, makes it possible for programs to adjust colors before printing so that the color of images on the screen more closely match the color of those images when they are printed.

 **NOTE:** The ICM control is typically set to **ICM Disabled**.

True Type Font

Use **Substitute with Device Font** (the default setting) to print documents that contain TrueType fonts by using equivalent printer fonts. This permits faster printing; however, you might lose special characters that the equivalent printer font does not support. Select **Download as Softfont** to download TrueType fonts for printing instead of using printer fonts.

Document Options

The **Document Options** setting contains the following controls:

- [Advanced Printing Features](#)
- [Print Optimizations](#)

- [Printer Features](#)
- [Layout Options](#)

Advanced Printing Features

When the **Advanced Printing Features** setting is **Enabled**, metafile spooling is turned on and **Finishing** tab options such as **Page Order**, **Booklet Layout**, and **Pages per Sheet** are available, depending on your product.

Enhanced metafile spooling is used to greatly reduce the amount of time that elapses between a request to print (initiated by an application) and the return of control to the application by the operating system.

For normal printing, leave the **Advanced Printing Features** setting at the default (**Enabled**). If compatibility problems occur, you can disable the feature. However, some advanced printing features might still appear in the print driver, even though they have been disabled. If you select an advanced printing feature in the print driver that has been disabled on the **Advanced** tab, the feature is automatically re-enabled.

Print Optimizations

The default setting for **Print Optimizations** is **Enabled**. When this feature is enabled and your document contains overlapping text and graphics, the text that is placed on top of a graphic might not print correctly. If the printed output is not correct, you can disable this feature. When this feature is disabled, print optimization-features, such as substituting device fonts for TrueType fonts and scanning for horizontal and vertical rules, are turned off.

Printer Features

The **Printer Features** setting contains the following controls:

- **Print All Text as Black**

The feature is **Disabled** by default. When **Enabled** is selected, the driver prints all text as black regardless of the original document text color. Color text is printed as black, except for white text, which remains white. (White text is a reliable method of printing reverse typeface against a dark background.) This setting does not affect graphic images on the page, nor does it affect any text that is part of a graphic.

- **Send True Type as Bitmap**

Send True Type as Bitmap provides an alternative for software programs that have trouble using TrueType fonts for special graphic aspects such as shading, rotation, or slanting. The setting is **Disabled** (off) by default. The TrueType fonts are converted to bitmap soft fonts before downloading. The **Enabled** setting causes the driver to send TrueType fonts to the product as outlines, which retains the standard format (outline) of the fonts.

- **Raster Compression**

Use the **Raster Compression** feature to select the graphics-compression method:

- **Automatic.** The software determines the best compression method to use.
- **Best Quality.** This option forces the software to use a lossless compression method. (Lossless means that no data is lost during compression.)
- **Maximum Compression.** Where applicable, this option requires the software to always use a lossy compression method (some data is lost).

- **Alternative Letterhead Mode**

When selected, this option eliminates the need to flip or reload letterhead or preprinted paper in a tray, whether you are printing on one or both sides of the sheet. Load the paper as you would for printing on both sides. If the product tray has an icon that indicates whether to load paper either face-up or face-down, load the paper in opposite orientation of that shown.

When this option is selected, you must use one of the following options in the **Paper type** setting:

- Letterhead
- Preprinted

 **NOTE:** Because **Alternative Letterhead Mode** is available only if the product is equipped with an automatic duplexing unit, the HP Color LaserJet CP4525 and HP Color LaserJet CP4525n models do not support this option.

Layout Options

The **Layout Options** setting contains the **Page Order** setting.

Page Order specifies the order in which the pages of your document are printed. **Front to Back** prints the document so that page 1 prints first. **Back to Front** prints the document so that page 1 prints last.

 **NOTE:** The page-ordering operation works on whole sheets of paper rather than on individual logical pages. Accordingly, if you set **Pages per Sheet** (on the **Finishing** tab) to be greater than one, the ordering of logical pages on a physical sheet of paper does not change.

Printing Shortcuts tab features

- [Use defined printing shortcuts](#)
- [Create a custom printing shortcut](#)

 **NOTE:** The **Printing Shortcuts** tab is located on the **Printing Preferences** tab set. For information about how to access these tabs, see [Printing Preferences driver tabs on page 101](#),

Use the **Printing Shortcuts** tab to store specific combinations of driver settings for easy use.

The following figure shows the **Printing Shortcuts** tab.

Figure 4-3 Printing Shortcuts tab

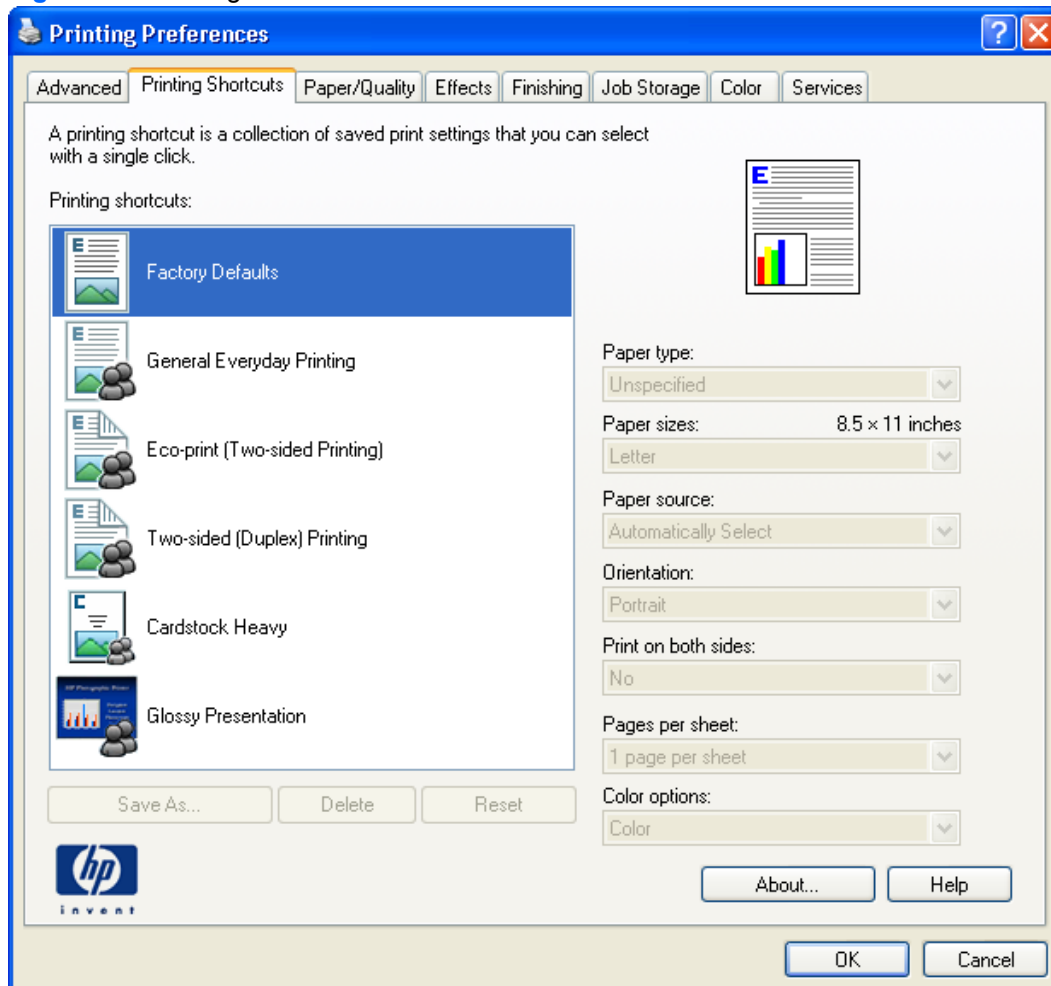

The **Printing Shortcuts** tab is a new tab that appears on the HP PCL 6 Print Driver beginning with the HP Color LaserJet CM4730 MFP. In previous drivers, the Print Task Quick Sets appeared in most of the driver tabs, and was used to capture commonly used driver settings. Like Quick Sets, the **Printing Shortcuts** tab saves commonly used driver settings under a shortcut name.

- [Use defined printing shortcuts](#)
- [Create a custom printing shortcut](#)

Use defined printing shortcuts

The **Printing Shortcuts** tab contains the following pre-defined shortcuts:

- [Factory Defaults](#)
- [General Everyday Printing](#)
- [Eco-print \(Two-sided Printing\)](#)
- [Two-sided \(Duplex\) Printing](#)
- [Cardstock Heavy](#)
- [Glossy/Presentation](#)

Factory Defaults

When **Factory Defaults** is selected, the customizable options are grayed out, locking in those default options.

The **Factory Defaults** are as follows:

- **Paper type: Unspecified**
- **Paper sizes: Letter** (This setting changes according to country/region.)
- **Paper source: Automatically select**
- **Orientation: Portrait**
- **Print on both sides: No**
- **Pages per sheet: 1 page per sheet**

General Everyday Printing

When **General Everyday Printing** is selected, the following controls are available:

- **Paper type:**
- **Paper sizes:**
- **Paper source:**
- **Orientation:**
- **Print on both sides:**
- **Pages per sheet:**

When options other than the defaults are selected, the **Save as...** and **Reset** buttons become active.

Click **Save as...** to create a custom printing shortcut.

Click **Reset** to change customized settings back to the default settings.

Paper type

The following options are available:

- **Unspecified** (default)
- **Plain**
- **HP LaserJet 90g**
- **HP Color Laser Matte 105g**
- **HP Premium Choice Matte 120g**
- **HP Color Laser Brochure Matte 160g**
- **HP Cover Matte 200g**
- **HP Matte Photo 200g**
- **HP Premium Presentation Matte 120g**
- **HP Presentation Soft Gloss 120g**
- **HP Professional Soft Gloss 120g**
- **HP Presentation Glossy 130g**
- **HP Professional Laser Glossy 130g**
- **HP Color Laser Brochure Glossy 160g**
- **HP Color Laser Photo Glossy 220g**
- **Light 60-74g**
- **Intermediate 85-95g**
- **Mid-Weight 96-110g**
- **Heavy 111-130g**
- **Extra Heavy 131-175g**
- **Cardstock 176-220g**
- **Card Glossy 176-220g**
- **Mid-Weight Glossy 96-110g**
- **Heavy Glossy 111-130g**
- **Color Laser Transparency**
- **Labels**
- **Letterhead**
- **Envelope**
- **Preprinted**

- **Prepunched**
- **Colored**
- **Bond**
- **Recycled**
- **Rough**
- **HP Tough Paper**
- **Opaque Film**

Paper sizes

The following options are available:

- **A4/Letter** (default)
- **Legal**
- **Executive**
- **Statement**
- **8.5x13**
- **4x6**
- **5x7**
- **5x8**
- **A4**
- **A5**
- **A6**
- **RA4**
- **B5 (JIS)**
- **B6 (JIS)**
- **10x15cm**
- **16k 195x270mm**
- **16k 184x260mm**
- **16k 197x273mm**
- **Japanese Postcard**
- **Double Japan Postcard Rotated**
- **Envelope #9**
- **Envelope #10**

- **Envelope Monarch**
- **Envelope B5**
- **Envelope C5**
- **Envelope C6**
- **Envelope DL**

Paper source

The following options are available:

- **Automatically Select** (default)
- **Printer auto select**
- **Manual Feed in Tray 1**
- **Tray 1**
- **Tray 2**
- **Tray 3** (HP Color LaserJet CP4525xh only; optional on all other HP Color LaserJet Enterprise CP4020-CP4520 Series models).
- **Tray 4** (HP Color LaserJet CP4525xh only; optional on all other HP Color LaserJet Enterprise CP4020-CP4520 Series models).
- **Tray 5** (HP Color LaserJet CP4525xh only; optional on all other HP Color LaserJet Enterprise CP4020-CP4520 Series models).

Orientation

The following options are available:

- **Portrait** (default)
- **Landscape**

Print on both sides



NOTE: Because the HP Color LaserJet CP4525 and HP Color LaserJet CP4525n models do not include a duplexing unit, the **Print on both sides** option is available, but duplexing is a manual process.

The following options are available:

- **No** (default)
- **Yes, Flip Over**
- **Yes, Flip Up**

Pages per sheet

The following options are available:

- **1 page per sheet** (default)
- **2 pages per sheet**
- **4 pages per sheet**
- **6 pages per sheet**
- **9 pages per sheet**
- **16 pages per sheet**

Eco-print (Two-sided Printing)

- **Paper sizes: Letter/A4**
- **Paper source: Automatically Select**
- **Pages per sheet: 1 page per sheet**
- **Print on both sides: Yes, flip over**
- **Paper type: Unspecified**
- **Orientation: Portrait**

Two-sided (Duplex) Printing

 **NOTE:** Because the HP Color LaserJet CP4525 and HP Color LaserJet CP4525n models do not include a duplexing unit, the **Two-sided (Duplex) Printing** option is available, but duplexing is a manual process.

When **Two-sided (Duplex) Printing** is selected, the following options are selected.

- **Paper type: Unspecified**
- **Paper sizes: Letter** (This setting changes according to country/region.)
- **Paper source: Automatically Select**
- **Orientation: Portrait**
- **Print on both sides: Yes, flip over**
- **Pages per sheet: 1 page per sheet**

Cardstock Heavy

- **HP Cover Matte 200g**
- **Paper sizes: Letter** (This setting changes according to country/region.)
- **Paper source: Automatically Select**
- **Orientation: Portrait**

- **Print on both sides: Yes, flip over**
- **Color options: Color**

Glossy/Presentation

- **Paper type: Unspecified**
- **Paper sizes: Letter** (This setting changes according to country/region.)
- **Paper source: Automatically Select**
- **Orientation: Portrait**
- **Print on both sides: Yes, flip over**
- **Color theme:** (unavailable, appears dimmed)

Create a custom printing shortcut

1. Select **General Everyday Printing** as a base.
2. Select the appropriate print settings on the **Printing Shortcuts** tab or use the settings on any of the **Printing Preferences** tabs.
3. On the **Printing Shortcuts** tab, click **Save As....** The **Printing Shortcuts** dialog box appears.

Figure 4-4 Printing Shortcuts dialog box

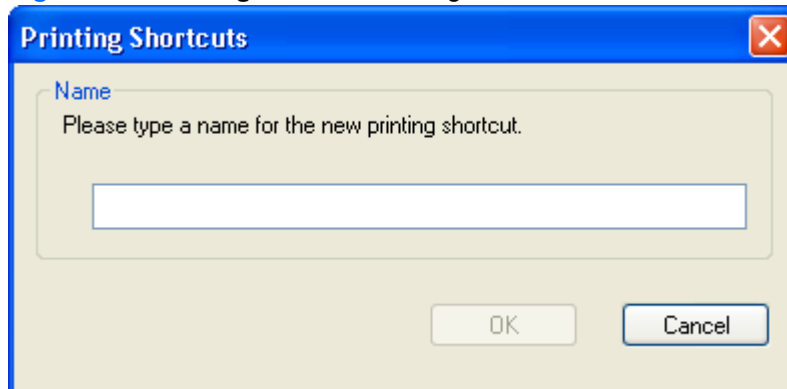

4. Type a name for the custom printing shortcut, and then click **OK**. The custom printing shortcut appears in the **Printing Shortcuts** list.
5. To delete a custom printing shortcut, click the custom shortcut, then click the **Delete** button.

Paper/Quality tab features

 **NOTE:** The **Paper/Quality** tab is located on the **Printing Preferences** tab set. For information about how to access these tabs, see [Printing Preferences driver tabs on page 101](#),

Use the **Paper/Quality** tab to specify paper size, type, and source. You can also use this tab to specify different paper selections for the front cover, first page, other pages, last page, and back cover of the document. The following figure shows the **Paper/Quality** tab.

Figure 4-5 Paper/Quality tab

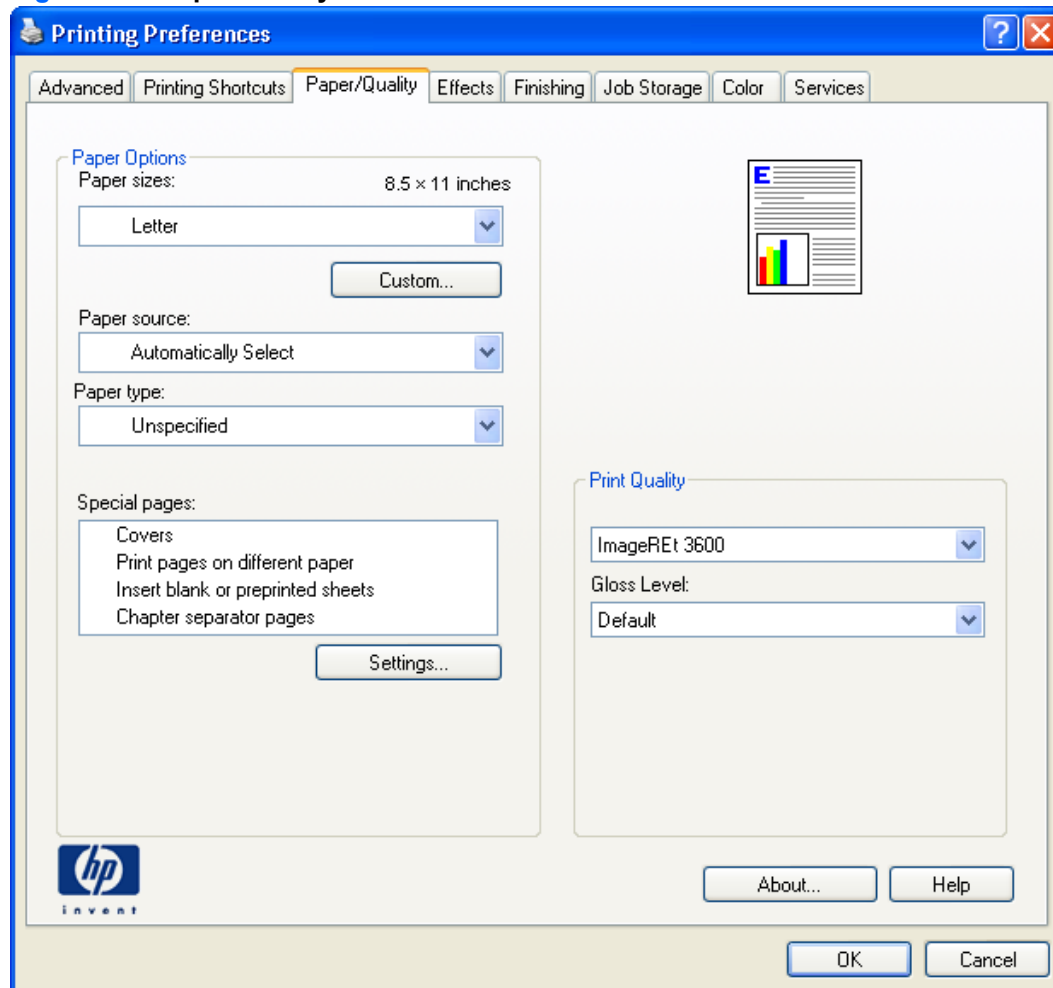

The **Paper/Quality** tab contains the following control sets:

- [Paper Options](#)
- [Document preview image](#)
- [Print Quality](#)

Paper Options

The settings specified in the **Paper Options** group box on the **Paper/Quality** tab apply to all of the pages of the document. The following figure shows the **Paper Options** group box and the selections that are available by default.

Figure 4-6 Paper Options group box

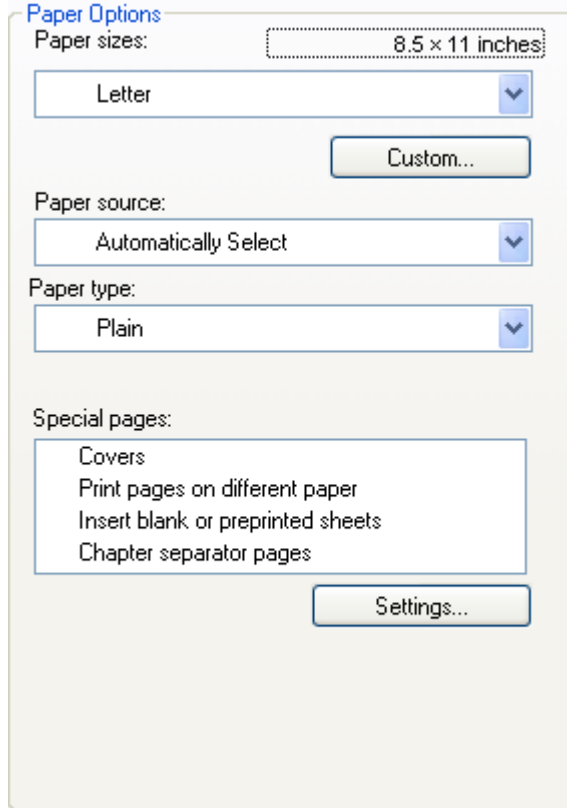

The settings in the **Paper Options** group box are described in the following order:

- [Paper sizes](#)
- [Custom Paper Size](#)
- [Paper source](#)
- [Paper type](#)
- [Special pages](#)

Paper sizes

The **Paper sizes** setting is a drop-down menu that lists all of the supported paper sizes.

When you move the mouse over the dimensions label, the mouse cursor changes from an arrow to a gloved hand. Click the dimensions label to toggle between English and metric units.

Because paper-size settings in most software programs override driver settings, it is generally best to use the driver to set paper size only when you are printing from software programs that do not include a paper-size setting, such as NotePad, or when you are producing a book or a booklet that does not require different paper sizes.

 **NOTE:** Certain software programs can override the size command and specify different paper sizes within a single document.

When you change the print-driver setting to a paper size that is not currently loaded in the product, a control-panel message appears that prompts you to load the paper size or select another tray.

For information about paper sizes, see [Media attributes and commands on page 219](#).

When the **Settings** under the **Special Pages** section have been changed, the **Paper sizes**, **Paper source**, and **Paper type** menus change also, offering a variety of options. For more information, see [Special pages on page 122](#).

Custom Paper Size

The **Custom Paper Size** dialog box appears when you click **Custom...** on the **Paper/Quality** tab. The following figure shows the initial appearance of the **Custom Paper Size** dialog box.

Figure 4-7 Custom Paper Size dialog box

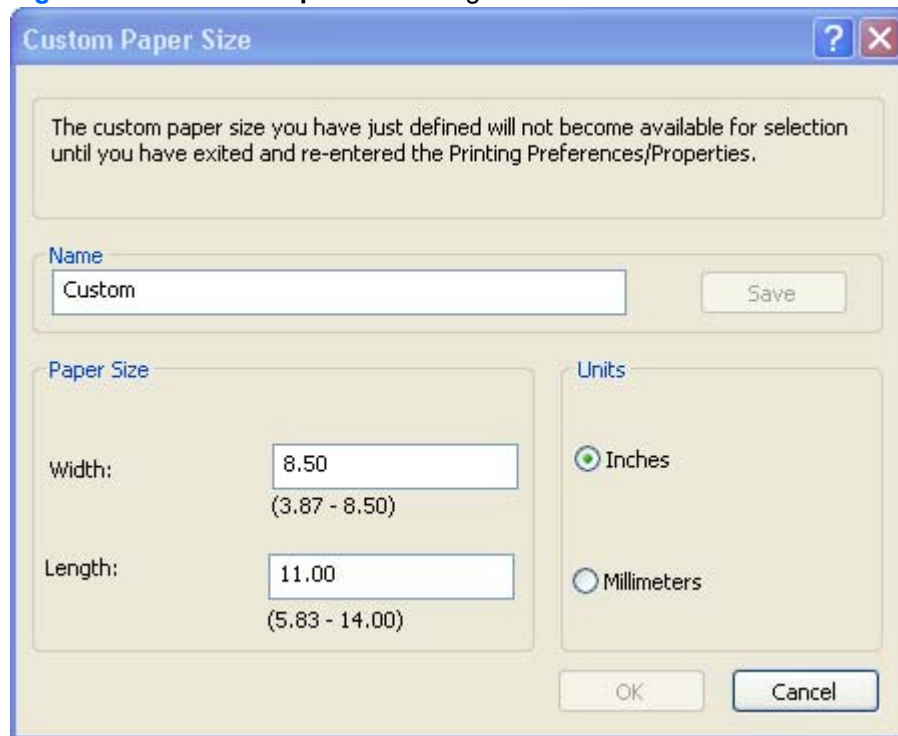

 **NOTE:** The HP Color LaserJet Enterprise CP4020-CP4520 Series product supports custom paper sizes up to 14 inches in length. To use this paper size, set the custom paper size to match the custom paper size that you are using, up to 14 inches in length.

Name

Use the **Name** text box to type a new name for a custom paper size. When you change the name to something other than **Custom**, the **Save** and **OK** buttons become active.

The name that appears in the **Name** text box depends on the following conditions:

- If a saved custom paper size has been selected from the drop-down menu on the **Paper/Quality** tab, then the **Name** text box shows the name of the selected custom paper size.
- If a standard paper size has been selected on the **Paper/Quality** tab, then the **Name** text box shows the default name of **Custom** .
- If a new name has been typed into the **Name** text box for the purpose of saving a new size or renaming an existing size, then that new name will remain in the text box until the new size is saved or the dialog box is closed.

If you type a new name into the **Name** text box, but then do not click **Save**, you can change the width and height values without losing the name. However, if you close the dialog box without clicking **Save**, any unsaved name or size values are lost without warning.

Paper size

The width and height values can be changed by typing numeric strings into the edit boxes in the **Paper Size** group box.

Any entry that is greater than the maximum limits of the width and height control is rounded down to the maximum valid entry, while any entry that is smaller than the minimum limits of the width and height control is rounded up to the minimum valid entry.

If units are in millimeters, the custom paper-size range minimum is the limit rounded up to the nearest whole millimeter. The custom paper-size range maximum is the limit rounded down to the nearest whole millimeter. Any non-numerical entry reverts to the minimum value. Width and height entries are validated when the focus has changed.

The resolution of each control is 1 millimeter or 1/10 of an inch, depending on the current measurement units.

Units

To change measurement units, click one of the options in the **Units** group box (either **Inches** or **Millimeters**).

Custom width and height control limits

The minimum paper size for the HP Color LaserJet Enterprise CP4020-CP4520 Series product is 76 x 127 mm (3 x 5 in) and the maximum is 215.90 x 355.60 mm (8.50 x 14.00 in). The following table summarizes paper size limits for each paper-handling device.

Table 4-1 PCL 6 custom paper sizes

Tray	Dimensions	Minimum	Maximum
Tray 1 (100-sheet multipurpose)	Width	76 mm (3 in)	216 mm (8.5 in)
	Length	127 mm (5 in)	356 mm (14.0 in)
Tray 2 (250-sheet)	Width	148.0 mm (5.83 in)	216 mm (8.5 in)
	Length	210.0 mm (8.27 in)	356 mm (14.0 in)
Tray 3 (500-sheet)	Width	148 mm (5.38 in)	216 mm (8.5 in)
	Length	210 mm (8.27 in)	356 mm (14.0 in)

Table 4-1 PCL 6 custom paper sizes (continued)

Tray	Dimensions	Minimum	Maximum
Tray 4 (500-sheet)	Width	148 mm (5.38 in)	216 mm (8.5 in)
	Length	210 mm (8.27 in)	356 mm (14.0 in)
Tray 5 (500-sheet)	Width	148 mm (5.38 in)	216 mm (8.5 in)
	Length	210 mm (8.27 in)	356 mm (14.0 in)

Paper source

The **Paper source** setting specifies the source tray to use for printing a document. The list of source trays depends on the product accessories that are installed. Any optional source trays that are installed through the **Device Settings** tab also appear here.

The **Paper source** drop-down menu can contain the following options, depending on what has been installed on the product:

- **Automatically select**
- **Printer Auto Select**
- **Manual Feed in Tray 1**
- **Tray 1** (100-sheet multipurpose tray)
- **Tray 2** (250-sheet tray)
- **Tray 3** (500-sheet paper tray, HP Color LaserJet CP4525xh only; optional on all other HP Color LaserJet Enterprise CP4020-CP4520 Series models)
- **Tray 4** (HP Color LaserJet CP4525xh only; optional on all other HP Color LaserJet Enterprise CP4020-CP4520 Series models).
- **Tray 5** (HP Color LaserJet CP4525xh only; optional on all other HP Color LaserJet Enterprise CP4020-CP4520 Series models).

The default setting is **Automatically Select**. When this setting is selected, the HP Color LaserJet Enterprise CP4020-CP4520 Series uses the source tray that supports the paper size that you have selected. If you select a source tray other than **Automatically select**, make sure that the correct paper size is loaded in the source tray. For information about paper sources, see [Media attributes and commands on page 219](#).

Paper type

The **Paper type** drop-down menu shows the first few paper types that the HP Color LaserJet Enterprise CP4020-CP4520 Series supports and an entry for **More**. Clicking **More** opens the **Type Is** dialog box. Click the **+** next to **Type Is** and its subcategories to view all of the paper types that the product supports, listed in the following categories.

- **Everyday <96g**
 - **Unspecified**
 - **Plain**
 - **Light 60-74g**

- **Bond**
- **Recycled**
- **Presentation 96-130g**
 - **HP Color Laser Matte 105g**
 - **HP Premium Choice Matte 120g**
 - **HP Presentation Soft Gloss 120g**
 - **HP Professional Soft Gloss 120g**
 - **HP Presentation Glossy 130g**
 - **HP Professional Laser Glossy 130g**
 - **Mid-Weight 96-110g**
 - **Heavy 111-130g**
 - **Mid-Weight Glossy 96-110g**
 - **Heavy Glossy 111-130g**
- **Brochure 131-175g**
 - **HP Color Laser Brochure Matte 160g**
 - **HP Color Laser Brochure Glossy 160g**
 - **Extra Heavy 131-175g**
- **Photo/Cover 176-220g**
 - **HP Cover Matte 200g**
 - **HP Matte Photo 200g**
 - **Cardstock 176-220g**
 - **Card Glossy 176-220g**
 - **HP Color Laser Photo Glossy 220g**
- **Other**
 - **Color Laser Transparency**
 - **Labels**
 - **Letterhead**
 - **Envelope**
 - **Preprinted**
 - **Prepunched**
 - **Colored**

- **Rough**
- **HP Tough Paper**
- **Opaque Film**

The default setting is **Unspecified**.

No mechanism exists for manually adding custom paper types through the driver. Use HP Web Jetadmin to add custom paper types. Custom types can be added only by using bidirectional communication, so they must already exist in the product when the bidirectional query occurs. If bidirectional communication is enabled, then an updated list of paper types is returned. If bidirectional communication is not enabled, then the driver looks for custom paper types that have been saved from a previous bidirectional communication query, and uses those. Otherwise, no custom paper types are available through the driver.

 **NOTE:** To download a current version of HP Web Jetadmin and for the latest list of supported host systems, go to the following Web site:

www.hp.com/go/webjetadmin

If you select a setting other than the default, make sure that the correct paper type is loaded in the tray that you selected in the **Paper source** setting. For more information about paper types, see [Media attributes and commands on page 219](#).

When you change the print-driver setting to a paper type that is not currently loaded in the product, a control-panel message appears that prompts you to load the paper type or select another tray.

Special pages

To specify special pages to be used, click the **Settings** button under **Special Pages**.

Covers

To use specific cover settings, click **Covers** in the **Special Pages** group box.

Use the **Covers** options to include a blank or preprinted cover on a document, or to include a front/back cover from a source tray that is different from the one used for the remainder of the document.

The following are the **Covers** options:

- **Add a blank or preprinted cover:** Select which cover is customized: **Front**, **Back**, or **Both**.
- **Paper source:** The **Paper source** setting specifies the source tray to use for adding a front and/or back cover to the document. The list of source trays depends on the accessories that are installed. Any optional trays that are installed through the **Device Settings** tab also appear here.
- **Paper type:** The **Paper type** setting specifies the paper size to use for front and/or back covers. Changes made to the **Paper type** setting here override any previous **Paper type** settings using the same paper source.

 **NOTE:** The same size of paper will be used for the entire print job.

When you change the type and source of the paper and covers, the settings remain configured until you close the software program.

Print pages on different paper

Use the **Print pages on different paper** options to select an alternative paper type or source for the first, last, or other pages of a document.

The following figure shows the **Print pages on different paper** settings and options.

Figure 4-8 Print pages on different paper

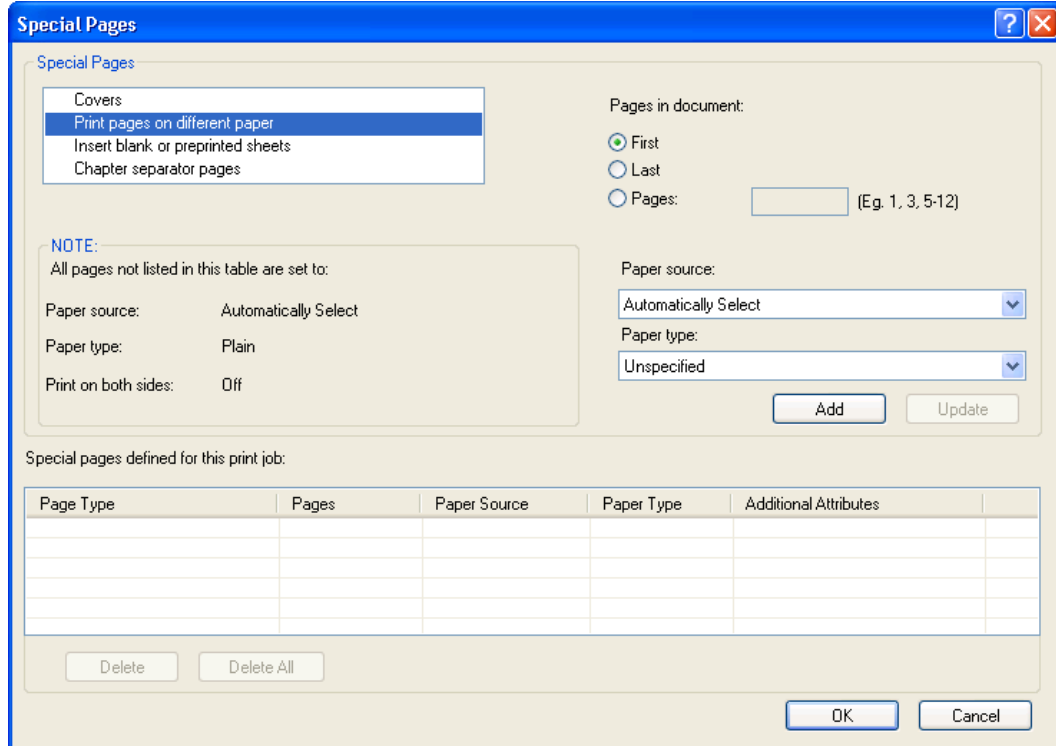

The following are the **Print pages on different paper** options:

- **Pages in document.** Select which pages are customized: the **First** page, the **Last** page, or specify a page range with the **Pages** option.
- **Paper source:** The **Paper source** setting specifies the source tray to use for printing a document. The list of source trays depends on the accessories that are installed. Any optional trays that are installed through the **Device Settings** tab also appear here.
- **Paper type:** The **Paper type** drop-down menu shows all of the paper types that the HP Color LaserJet Enterprise CP4020-CP4520 Series supports.

 **NOTE:** The same type of paper is used for the entire print job.

When you change the type and source of the paper and covers, the settings remain configured until you close the software program.

Insert blank or preprinted pages

Use the **Insert blank or preprinted pages** options to designate where to insert preprinted pages or blank pages into a document.

The following figure shows the **Print pages on different paper** settings and options.

Figure 4-9 Insert blank or preprinted pages

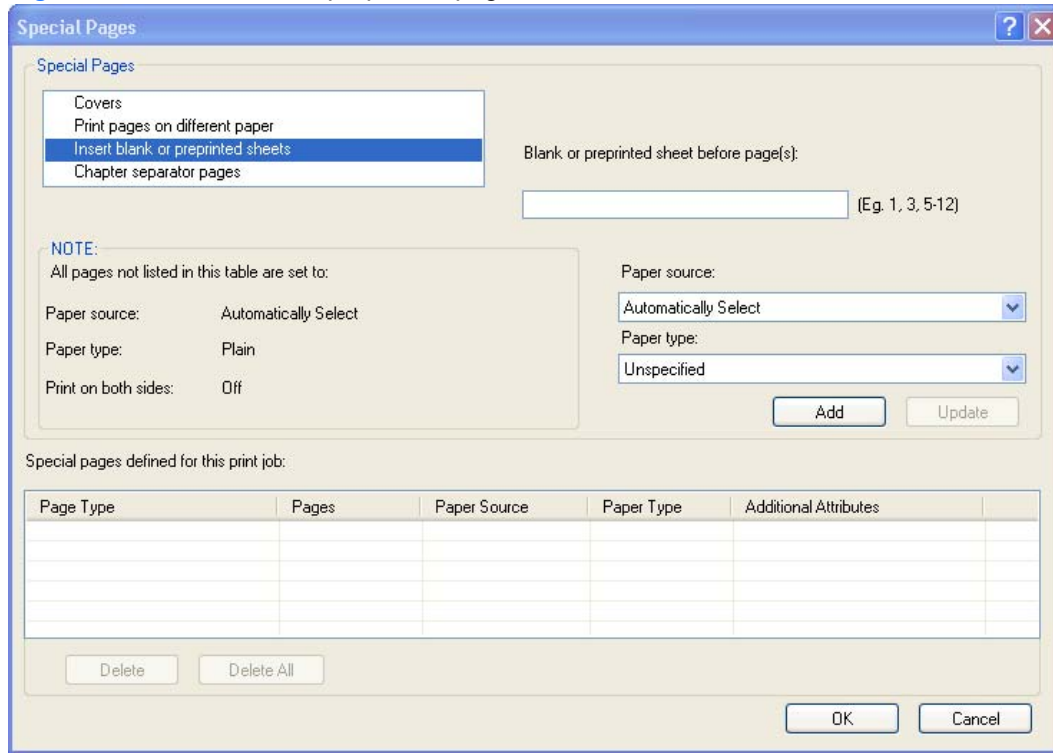

The following are the **Insert blank or preprinted pages** options:

- **Blank or preprinted sheet before page(s):** Specify where in the document you want to insert blank or preprinted pages by designating the page numbers or page ranges that the blank or preprinted pages will precede. For example, to insert a blank or preprinted page on page four, specify **5** in the **Blank or preprinted sheet before page(s):** option.
- **Paper source:** The **Paper source** setting specifies the source tray to use for printing a document. The list of source trays depends on the accessories that are installed. Any optional trays that are installed through the **Device Settings** tab also appear here.
- **Paper type:** The **Paper type** drop-down menu shows all of the paper types that the HP Color LaserJet Enterprise CP4020-CP4520 Series supports.

Chapter separator pages

Use the **Chapter separator pages** options to designate where the first page of a chapter appears in the document.

The following figure shows the **Chapter separator pages** settings and options.

Figure 4-10 Chapter separator pages

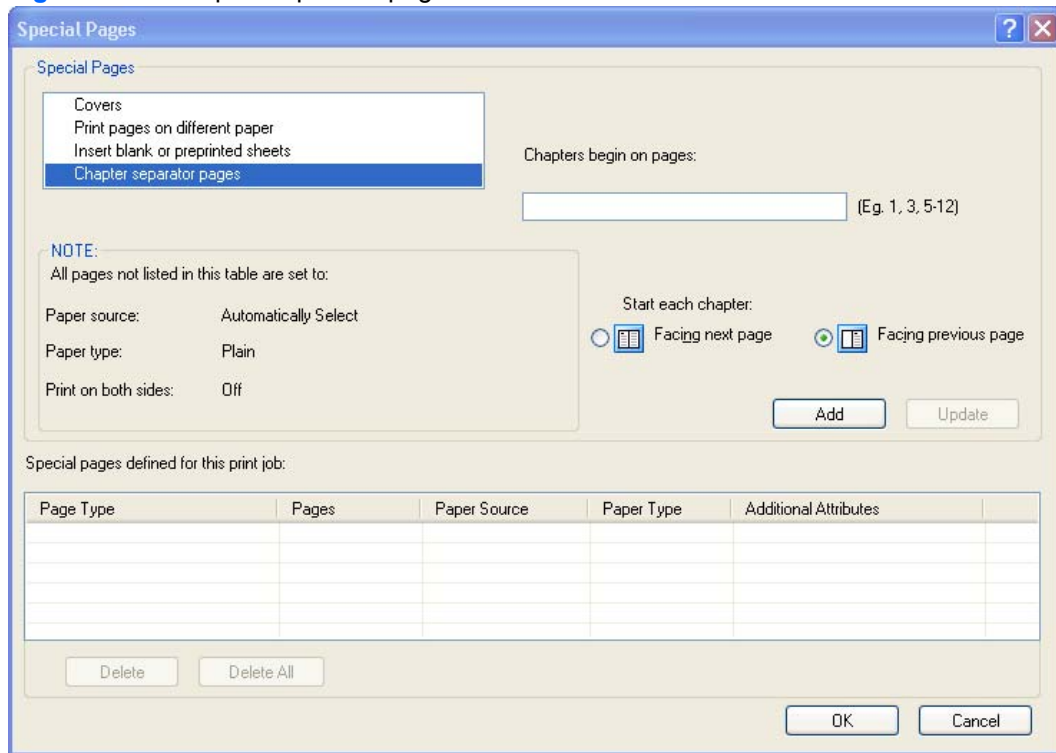

The following are the **Chapter separator pages** options:

- **Chapters begin on pages:** Specify where in the document the chapters begin by designating a page number for each chapter.
- **Start each chapter:** Select **Facing next page** to make each chapter begin on the left side of the document. Select **Facing previous page** to make each chapter begin on the right side of the document.

Document preview image

The document preview image is a line-drawn image of a page that represents graphics and text. The document preview image is always oriented so that the contents of the page are right-side-up. The document preview image appears in the upper-right corner of the following **Printing Preferences** driver tabs:

- **Printing Shortcuts**
- **Paper/Quality**
- **Effects**
- **Finishing**
- **Color**

Switching between tabs does not change the location or appearance of the document preview image. When you move the mouse over the document preview image, the mouse cursor changes from an arrow to a gloved hand. You can toggle between portrait and landscape page orientation by clicking the image.

Print Quality

The **Print Quality** group box contains the following controls:

- [Print Quality drop-down menu](#)

Print Quality drop-down menu

Use this control to select print quality. ImageREt settings precisely control colors by combining up to 4 colors and varying the amount of toner in a given area to create many smooth colors, sharp images, and crisp text.

The **Print Quality** drop-down menu contains the following resolution options.

- **ImageREt 3600**. This setting is selected by default.
- **1200 x 1200**. This setting may improve the rendering of fine lines and text.

 **NOTE:** The Gloss Level control is not operational on this product.

Effects tab features

 **NOTE:** The **Effects** tab is located on the **Printing Preferences** tab set. For information about how to access these tabs, see [Printing Preferences driver tabs on page 101](#),

Use the **Effects** tab to create unique paper effects such as scaling and watermarks. The following figure shows the **Effects** tab.

Figure 4-11 Effects tab

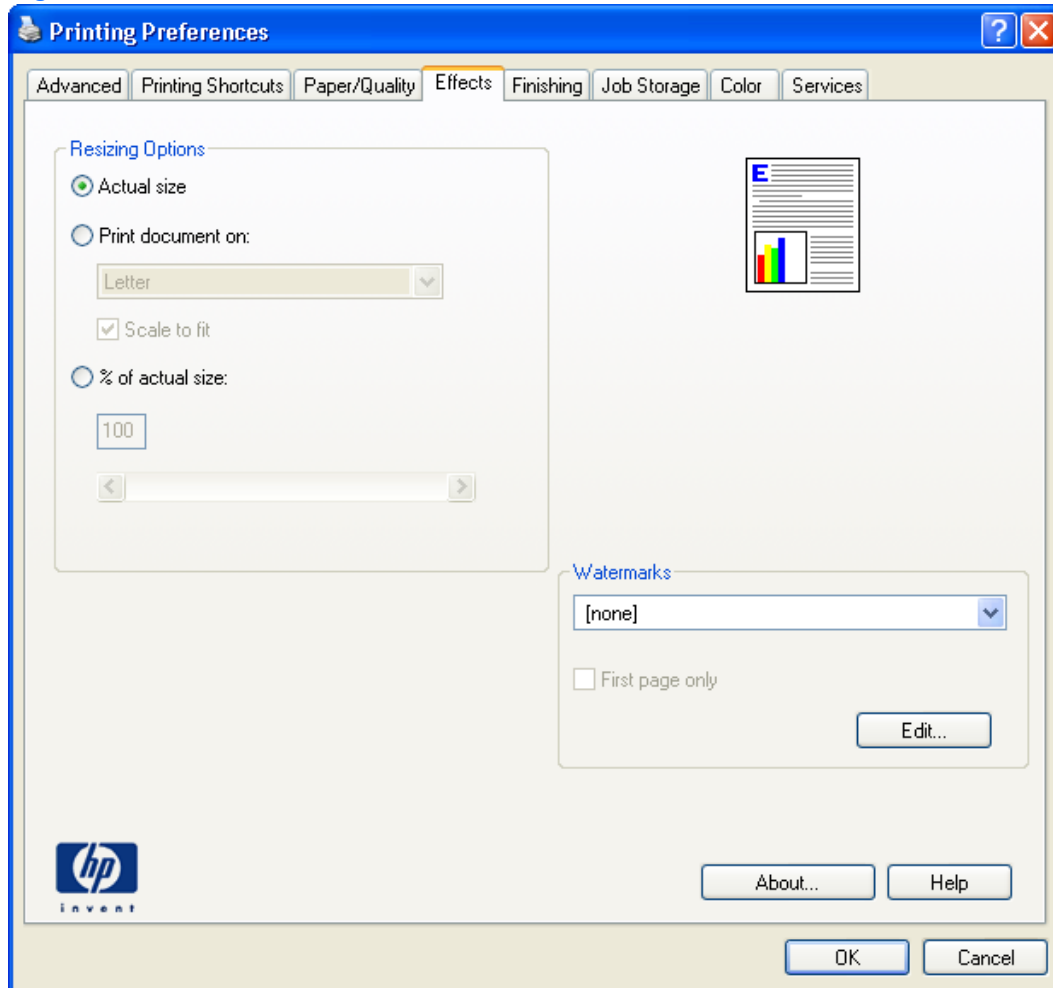

The **Effects** tab contains the following controls:

- [Resizing Options](#)
- [Document preview image](#)
- [Watermarks](#)

Resizing Options

The **Resizing Options** group box consists of the following controls:

- **Actual Size** (default)
- **Print Document On**

- **Scale to Fit**
- **% of Actual Size**

Actual Size

Actual Size is the default setting. It prints the document without changing the document size.

Print Document On

Click the **Print Document On** option to format the document for one paper size and then print the document on a different paper size, with or without scaling the image to fit the new paper size.

The **Print Document On** control is disabled by either of the following conditions:

- The **% of Actual Size** value is not 100.
- The **Pages per Sheet** value (on the **Finishing** tab) is not 1.

When **Print Document On** is selected, the drop-down menu shows the paper sizes on which you can print. The list contains all of the standard paper sizes that the selected paper source supports and any custom sizes that you have created. When **Print Document On** is selected, **Scale to Fit** is automatically selected. Clear this check box if you do not want your document reduced or enlarged to fit on the selected paper.

Scale to Fit

The **Scale to Fit** option box specifies whether each formatted document page image is scaled to fit the target paper size. By default, **Scale to Fit** is selected when **Print Document On** is selected. If the setting is turned off, then the document page images will not be scaled, and are instead centered at full size on the target paper. If the document size is larger than the target paper size, then the document image is clipped. If it is smaller, then it is centered within the target paper. The following figure shows preview images for a document formatted for Legal-size paper with the **Print Document On** check box selected, and the target size specified as **Letter**.

Figure 4-12 Preview images – Legal on Letter; **Scale to Fit** off (left) and on (right)

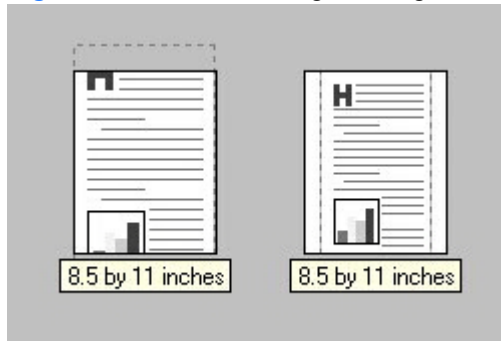

When the size for which the document is formatted (that is, the logical size) differs from the target size, the preview image uses a dashed gray line to show the boundaries of the logical page in relation to the target paper size.

% of Actual Size

The **% of Actual Size** option provides a slider bar and input box to use for scaling the percentage setting. The default setting in the entry box is 100% of actual size. Actual size is defined as the paper size that is selected within the driver or what the driver receives from the software program (if the software

program does not negotiate the paper size with the driver). The driver scales the page by the appropriate factor and sends it to the product.

The limits of the range are from 25% to 400%, and any values outside the range are adjusted to those limits as soon as the focus is removed from the control (that is, when the **Tab** key is pressed or another control is selected).

Any change to the scale also changes the page preview, which increases or decreases from the upper-left corner of the preview.

The slider bar controls the scale directly. The value in the edit box changes as the slider-bar indicator is dragged, and the document preview image is updated to the new image scale. Each click on the arrows increases or decreases the scale by 1%. Each click on the slider bar affects the scale by 10%.

You cannot achieve an exact value by dragging the slider-bar indicator. Instead, either use the slider-bar indicator to approximate the value that you want and then use the arrows to refine the value, or type the value into the entry box.

The following settings disable **% of Actual Size**:

- **Print Document On** (on the **Effects** tab) is selected
- **Pages per Sheet** (on the **Finishing** tab) is not 1

Document preview image

The document preview image is a line-drawn image of a page that represents graphics and text. The document preview image is always oriented so that the contents of the page are right-side-up. The document preview image appears in the upper-right corner of the following Printing Preferences driver tabs:

- **Printing Shortcuts**
- **Paper/Quality**
- **Effects**
- **Finishing**
- **Color**

Switching between tabs does not change the location or appearance of the document preview image. When you move the mouse over the document preview image, the mouse cursor changes from an arrow to a gloved hand. You can toggle between portrait and landscape page orientation by clicking the image.

Watermarks

Use the **Watermarks** feature to select a watermark, create a new watermark (text only), or edit an existing watermark. The following watermarks are preset in the driver:

- **(none)**
- **[Username]**
- **Confidential**
- **Draft**
- **SAMPLE**

The Watermarks feature can be configured using the Driver Configuration Utility.

If the **[Username]** watermark is selected, the driver will use the network username of the logged in user for the watermark.

The drop-down menu shows alphabetically sorted watermarks that are currently available on the system, plus the string "(none)," which indicates that no watermark is selected. This is the default setting. Any watermark that is selected from this list appears in the preview image.

When the **First Page Only** check box is selected, the watermark is printed only on the first page of the document. The **First Page Only** check box is disabled when the current watermark selection is "(none)."

Watermarks are applied to logical pages. For example, when **Pages per Sheet** is set to "4" and **First Page Only** is turned off, four watermarks appear on the physical page (one on each logical page).

Click **Edit**, and the **Watermark Details** dialog box appears.

Figure 4-13 Watermark Details dialog box

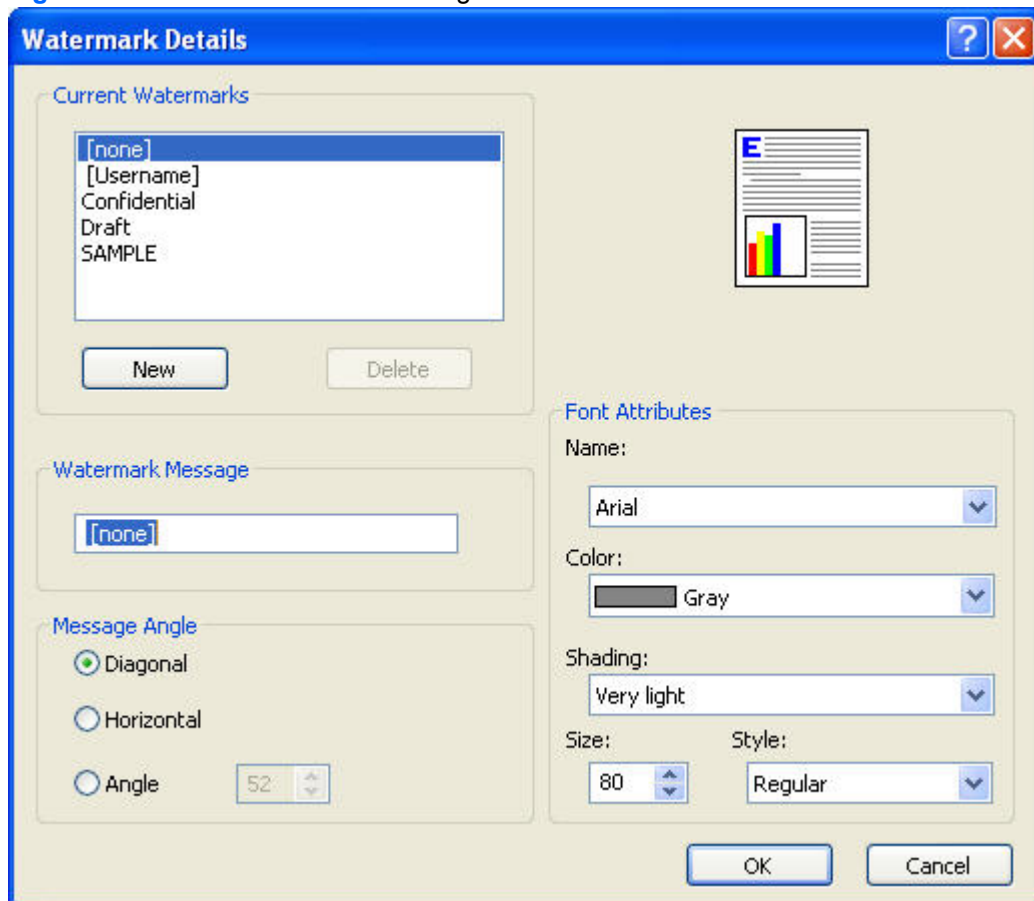

The dialog box shows a preview image and provides options for creating a new watermark and controlling the message angle and font attributes.

Click **OK** to accept all of the changes that are made in the **Watermark Details** dialog box. However, clicking **Cancel** does not cancel all of the changes. If you make changes to a watermark and then select a different watermark or click **New**, all of the changes are saved, and only the current, unsaved changes can be canceled.

Current watermarks

The **Current Watermarks** group box contains a list of available watermarks, both predefined watermarks that are available in the driver and any new watermarks that you have created.

To create a new watermark, click **New**. The new watermark appears in the **Current Watermarks** list and in the **Watermark Message** edit box as "**Untitled**" until you name it. The name that you type in the **Watermark Message** field appears in the **Current Watermarks** group box in the **Watermark Details** dialog box and in the **Watermarks** group box on the **Effects** tab.

To name the new watermark, type the selected watermark text in the **Watermark Message** edit box.

To delete a watermark, select the watermark in the **Current Watermarks** list, and then click **Delete**. A warning appears asking whether you are sure you want to delete the selected item. Click **Cancel** if you want to keep the watermark. Click **OK** to delete the selected watermark.

 **NOTE:** You can have no more than 30 watermarks in the **Current Watermarks** list at one time. When you reach the limit of 30 watermarks, the **New** button is disabled.

To edit an existing watermark, select the watermark in the **Current Watermarks** list. If you change the **Watermark Message** for that watermark, you are, in effect, creating a new watermark.

Watermark Message

The **Watermark Message** is also the name that identifies the watermark in the **Current Watermarks** list, except when more than one watermark has the same message. For example, you might want several different watermarks with the message DRAFT, each with a different typeface or font size. When this occurs, the string is appended with a space, a pound sign, and a number (for example, **Draft #2**). When a number is added, the number two is used first, but if the resulting name is also in the list, then the number increases until the name is unique (**Draft #3**, **Draft #4**, and so on).

Message Angle

Use the controls in the **Message Angle** group box to print the watermark in different orientations on the page. All settings center the watermark string within the page; the selection of a particular setting affects only the angle of the string placement. The following settings are available:

- **Diagonal.** This is the default setting. Select this setting to place the text along a line that spans the lower-left to upper-right corners of the page.
- **Horizontal.** Select this setting to place the text along a line that spans the mid-left and mid-right edges of the page.
- **Custom.** Select this setting to place the text at the specified angle across the page. Use the numeric spin box to select the angle.

Font Attributes

Use the controls in the **Font Attributes** group box to change the font and the shading, size, and style of the font.

The **Font Attributes** group box contains the following controls:

- **Name**

The **Name** drop-down menu lists fonts that are currently installed on the system. The default is language-dependent.

- **Color**

The **Color** drop-down menu contains the following selections:

- **Gray**
- **Red**
- **Yellow**
- **Green**
- **Cyan**
- **Blue**
- **Magenta**

- **Shading**

The default **Shading** setting for new and preset watermarks is **Very Light**. The following range of shades is available from the **Shading** drop-down menu:

- **Lightest**
- **Very Light** (default)
- **Light**
- **Medium Light**
- **Medium**
- **Medium Dark**
- **Dark**
- **Very Dark**
- **Darkest**

These values represent the intensity of the gray that is used. Select **Light** to produce a lightly saturated gray watermark. Select **Lightest** to produce the lightest shade of watermark. Select **Darkest** to produce a black watermark.

- **Size**

Font sizes from 1 to 999 points are available from the **Size** menu. The default point size is language-dependent.

- **Style**

The following settings are available:

- **Regular**
- **Bold**
- **Italic**
- **Bold Italic**

The default **Style** setting for new and preset watermarks is **Regular**.

Default watermark settings

The following table shows **Font Attribute** settings for new and preset watermarks.

Table 4-2 Font Attribute settings for new and preset watermarks

Setting	New watermark	Preset watermark
Name	Arial	Varies by language
Color	Gray	Gray
Shading	Very Light	Very Light
Size	80	Varies by language
Style	Regular	Regular

Click **OK** to accept all of the changes that have been made in the **Watermark Details** dialog box. Clicking **Cancel** does not cancel all of the changes. If you make changes to a watermark and then select a different watermark or click **New**, all of the changes are saved, and only the current, unsaved changes can be canceled.

Finishing tab features

 **NOTE:** The **Finishing** tab is located on the **Printing Preferences** tab set. For information about how to access these tabs, see [Printing Preferences driver tabs on page 101](#).

Use the **Finishing** tab to print booklets and control the paper output. The following figure shows the **Finishing** tab.

Figure 4-14 Finishing tab

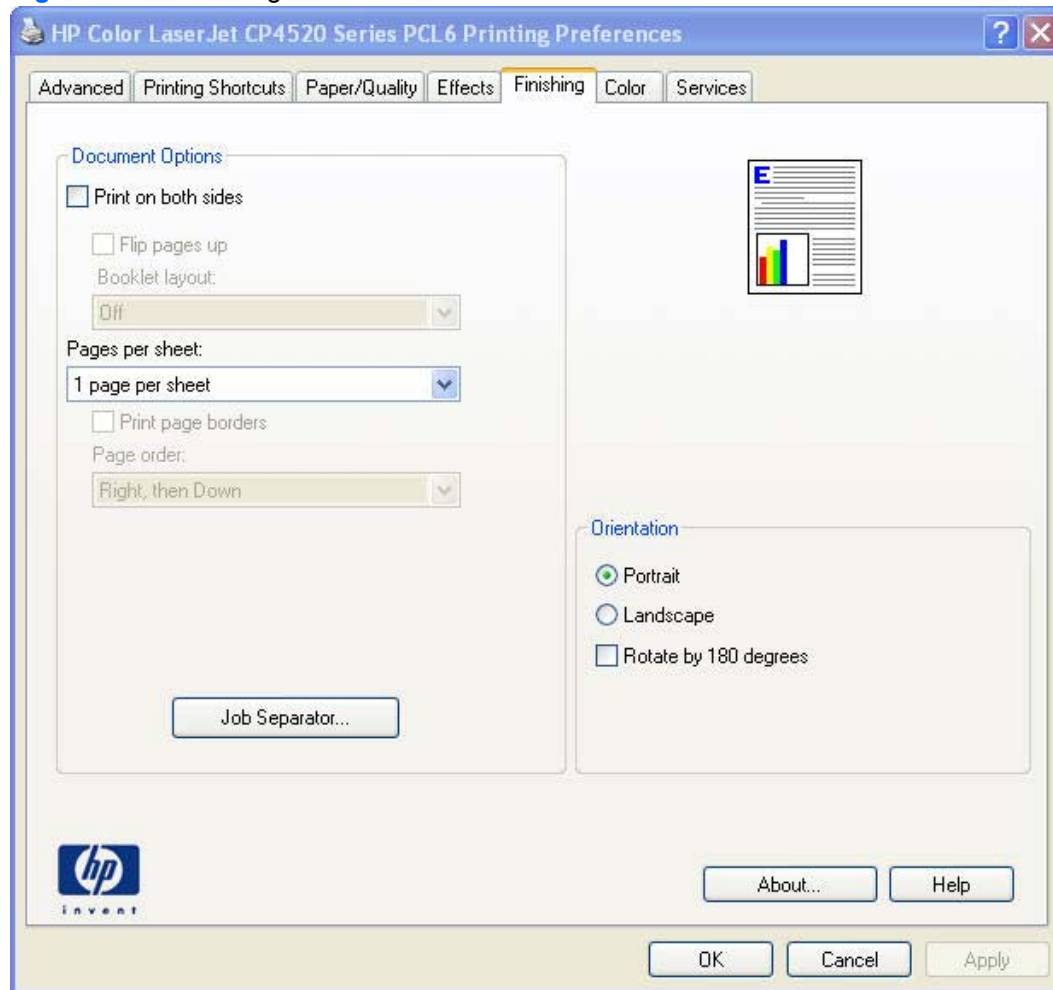

The **Finishing** tab contains the following controls:

- [Document Options](#)
- [Document preview image](#)
- [Orientation](#)

Document Options

The **Document Options** group box contains the following controls:

- [Print on Both Sides](#)
- [Flip Pages Up](#)

- [Booklet Layout](#)
- [Pages per Sheet](#)
- [Print Page Borders](#)
- [Page Order](#)

Print on Both Sides

 **NOTE:** This feature is called **Print on Both Sides (manually)** for the HP Color LaserJet CP4525 and the HP Color LaserJet CP4525n, because these models do not include an automatic duplex unit. For all other product models, this feature is called **Print on Both Sides**.

The default setting for the **Print on Both Sides** option is off (not selected). **Print on Both Sides** is available when the following conditions exist:

- **Paper type** on the **Paper** tab is set to any paper type *except for* the following types:
 - **Labels**
 - **Color Laser Transparency**
- **Paper sizes** is set to any paper size *except for* the following sizes:
 - **Envelope #10**
 - **Double Postcard (JIS)**
 - **Envelope #9**
 - **Envelope Monarch**
 - **Envelope B5**
 - **Envelope C5**
 - **Envelope C6**
 - **Envelope DL**

Print on both sides automatically

The duplexing unit in the HP Color LaserJet Enterprise CP4020-CP4520 Series product prints on two sides of a sheet of paper when the **Print on Both Sides** option is specified in the print job. The HP Color LaserJet Enterprise CP4020-CP4520 Series product comes with a duplexing unit installed in the following models:

- HP Color LaserJet CP4525dn
- HP Color LaserJet CP4525xh

These product models support smart duplexing. The smart duplexing feature increases printing performance by preventing one-page print jobs or single-sided pages of a duplexed print job from going through the duplexing unit even when the duplexing feature has been selected in the driver.

All paper types support the smart duplexing feature, except for paper types that cannot be printed on both sides (such as labels, transparencies, and envelopes) and the following paper types:

- Prepunched
- Preprinted
- Letterhead
- Cardstock

When the paper type is set to **Unspecified**, the smart duplexing feature is disabled.

To achieve the best print quality when printing on the second side of the page, the product needs to make adjustments to its print modes. When you select a paper type, you are, in effect, instructing the product to use a group of settings (such as fuser temperature and print speed) to print the paper with the best possible quality. This group of settings is known as print mode. A different print mode is used with each paper type. Print-mode adjustments for the second side of a duplexed page are automatic.

Print on both sides manually

Select the **Print on Both Sides (Manually)** check box to print on the second side of the paper for the HP Color LaserJet CP4525 and HP Color LaserJet CP4525n product models, which do not have a duplexing unit installed. Also, select **Print on Both Sides (Manually)** on the other HP Color LaserJet Enterprise CP4020-CP4520 Series product models for paper types that are not available when using the automatic duplexing unit, such as cardstock and thick paper.

Manually printing on the second side of a page is available when you are using the HP PCL 6 driver. If a duplexing unit is installed and manual duplexing is enabled in the driver, the product automatically prints on both sides of paper types that are supported for automatic duplexing (Letter, A4, Legal, and 8.5 x 11 only). For paper types that are *not* supported for automatic duplexing, a Help message appears prompting you to configure the driver settings for manual printing on both sides. Manual printing on both sides does not occur automatically.

Select the paper type that corresponds to the paper that you are using for the print job. The following paper types have a different print modes when you manually print on the second side:

- Plain
- Preprinted
- Letterhead
- Prepunched
- Bond
- Recycled
- Colored
- Rough

 **NOTE:** To make the **Print on Both Sides (Manually)** check box available in the document options, select the **Allow Manual Duplexing** option on the **Device Settings** tab in the print-driver **Properties** tab set. See [Installable Options on page 162](#).

If you want to print on both sides manually while using paper that is supported for automatic duplexing, you must select and apply the **Not Installed** setting on the **Allow manual duplexing** option on the **Device Settings** tab.

Cardstock paper can be manually printed on the second side, but no change occurs to the print mode. Transparencies and labels should *never* be manually printed on the second side.

To print a multiple-page document, follow these steps:

1. Select the **Print on Both Sides (Manually)** check box.
2. Click **OK**. The even-number pages of the document print.
3. When the control panel shows the **MANUALLY FEED** message, insert the stack of paper (on which the even-number pages have been printed) as indicated in the following figure.

Figure 4-15 Print on Both Sides Instructions dialog box

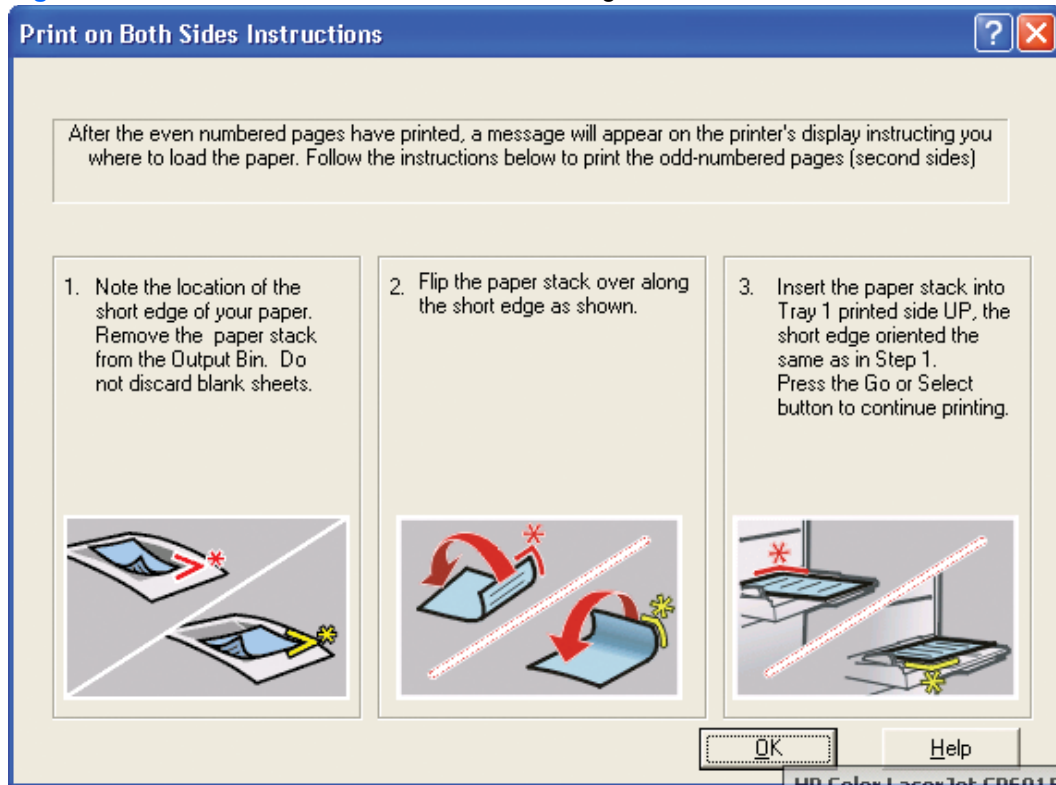

When you have completed the steps that appear in the dialog box, the second half of the print job prints on the back side of the stack of paper. The driver does not require the program to specifically support odd- and even-page printing, because the driver coordinates this function.

Flip Pages Up

Use the **Flip Pages Up** check box to specify the duplex-binding option. By default, the **Flip Pages Up** check box is not available. It is available only when **Print on Both Sides** is selected. The following table demonstrates the results of selecting this check box, depending on the paper orientation selected on the **Finishing** tab.

Table 4-3 Page orientation

Orientation (Finishing tab)	Flip Pages Up selected	Flip Pages Up not selected
Portrait	Short-edge binding	Long-edge binding
Landscape	Long-edge binding	Short-edge binding

When **Print on Both Sides** is selected, the document preview image changes to show a spiral binding along either the left edge or the top edge of the page. In addition, a folded-over corner appears in the lower-right portion of the preview image, indicating that printing occurs on the back side. An arrow on the folded-over corner points in the direction that the pages would be flipped if they were bound together.

Short-side binding is for print jobs with pages that read by flipping over like the pages of a calendar. Long-side binding is for print jobs with pages that read by turning like the pages of a book.

Booklet Layout

The **Booklet Layout** drop-down menu, visible when **Print on Both Sides** is selected, offers choices that are based on the current paper size. The default setting for the **Booklet Printing** drop-down menu is **Off**. The other settings have the following format, where **[paper size]** depends on the paper size that is set on the **Paper/Quality** tab:

- **Left Binding**
- **Right Binding**

When you select **Left Binding** or **Right Binding**, the document preview image changes to show the location of the binding. If the **Pages per Sheet** setting is on the default setting of 1, it automatically changes to **2 pages per sheet**. If you change the **Pages per Sheet** setting manually to 4, 6, 9, or 16 pages per sheet, the booklet setting is disabled. See [Pages per Sheet on page 139](#) for more information.

Book and Booklet Printing

The HP Color LaserJet Enterprise CP4020-CP4520 Series supports book and booklet printing.

A book is a print job consisting of at least two pages. It can have a different paper type for the front cover, first page, other pages, last page, or back cover. Use the **Covers** and **Print pages on different paper** settings on the **Paper/Quality** tab to select different paper for the front cover, first page, other pages, and back cover. For more information, see [Paper/Quality tab features on page 116](#).

A booklet is a print job that places two pages on each side of a sheet that can then be folded into a booklet that is half the size of the paper. Use the **Booklet Layout** drop-down menu on the **Finishing** tab to control booklet settings.

Print a booklet

1. Open the driver **Printing Preferences** tab set and click the **Printing Shortcuts** tab. For information about how to access the **Printing Preferences** tab set, see [Printing Preferences driver tabs on page 101](#).
2. Click to select **Booklet Printing**.

 **NOTE:** Typically, you select the size of each page of the booklet in your software program by clicking **File**, clicking **Page**, and then clicking **Setup**. If your software program does not allow you to set the paper size, use the **Paper sizes** drop-down menu on the **Printing Shortcuts** tab.

3. Select the appropriate settings from the following drop-down menus on the **Printing Shortcuts** tab.
 - **Paper type**
 - **Paper source**
 - **Orientation**
 - **Booklet Layout**
4. Click **OK** to print.

Pages per Sheet

Use the **Pages per Sheet** option to select the number of pages that you want to print on a single sheet of paper. If you choose to print more than one page per sheet, the pages appear smaller and are arranged on the sheet in the order that they would otherwise be printed. The **Pages per Sheet** drop-down menu provides six settings:

- **1 page per sheet** (this is the default)
- **2 pages per sheet**
- **4 pages per sheet**
- **6 pages per sheet**
- **9 pages per sheet**
- **16 pages per sheet**

 **NOTE:** When you select an option other than **2 pages per sheet**, booklet printing is unavailable.

Related controls indented beneath **Pages per Sheet** are **Print Page Borders** and **Page Order**, which become active when **Pages per Sheet** is greater than 1.

Print Page Borders

Print Page Borders sets a line around each page image on a printed sheet to help visually define the borders of each logical page.

Page Order

The **Page Order** drop-down menu contains four selections:

- **Right, then Down**
- **Down, then Right**
- **Left, then Down**
- **Down, then Left**

The preview document image changes to reflect alterations in these settings, as shown by the examples in the following figure.

Figure 4-16 Page-order preview images

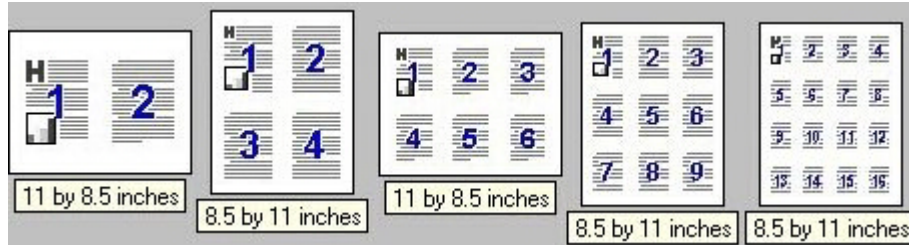

- 2 pages per sheet
- 4 pages per sheet
- 6 pages per sheet
- 9 pages per sheet
- 16 pages per sheet

Document preview image

The document preview image is a line-drawn image of a page that represents graphics and text. The document preview image is always oriented so that the contents of the page are right-side-up. The document preview image appears in the upper-right corner of the following **Printing Preferences** driver tabs:

- **Printing Shortcuts**
- **Paper/Quality**
- **Effects**
- **Finishing**
- **Color**

Switching between tabs does not change the location or appearance of the document preview image. When you move the mouse over the document preview image, the mouse cursor changes from an arrow to a gloved hand. You can toggle between portrait and landscape page orientation by clicking the image.

Orientation

Orientation refers to the layout of the image on the page, and does not affect the way that paper feeds into the product. You can specify the orientation of the print job. The three available orientations are portrait, landscape, and rotated. The default orientation is **Portrait**.

 **NOTE:** Nearly all software programs establish the orientation for the printed page, so the page orientation in the driver is useful only for the few software programs that do not set an orientation.

The **Orientation** group box contains the following options:

- **Portrait.** The top edge of the document is the shorter edge of the paper.
- **Landscape.** The top edge of the document is the longer edge of the paper.
- **Rotate by 180 degrees.** This creates a landscape or portrait orientation in which the image is rotated 180°. This setting is useful for printing prepunched paper.

You can toggle orientation between portrait and landscape by clicking the document preview image. If you select the **Rotate by 180 degrees** check box, no change occurs in the document preview image.

Job Storage tab features

 **NOTE:** The **Job Storage** tab is located on the **Printing Preferences** tab set. For information about how to access these tabs, see [Printing Preferences driver tabs on page 101](#).

Use the job-storage feature to store print jobs in the HP Color LaserJet Enterprise CP4020-CP4520 Series product memory or hard disk for printing at a later time.

The **Job Storage** tab appears among the driver tabs only if the job-storage feature is enabled on the **Device Settings** tab. To support job-storage features for complex jobs, or if you often print complex graphics, print postscript (.PS) documents, or use many downloaded fonts, HP recommends that you install additional memory, install a hard disk, or both. Added memory also gives you more flexibility in supporting job-storage features. A minimum total memory of 288 MB is required to use the **Proof and Hold** and **Personal Job** job-storage features. A hard disk is required to use the **Quick Copy** and **Stored Job** job-storage features.

After a hard disk is installed, the driver must be configured to reflect the changes in the product. If bidirectional communication is enabled in your environment, the Update Now feature can be used to update the drivers. For more information, see [Automatic Configuration on page 162](#).

To configure the drivers manually after installing a hard disk, follow these steps:

1. In Windows Vista and Windows 7, click the **Start** button, click **Control Panel**, click **Hardware and Sound**, and then click **Printers**.

In Windows XP, Windows Server 2003, and Windows Server 2008, click **Start**, click **Settings**, and then click **Printers and Faxes**.

2. Right-click the product name.
3. Click **Properties**.
4. Click the **Device Settings** tab.
5. Select **Installed** for the **Printer Hard Disk** under **Installable Options**, and then select **Installed** in the drop-down menu.
6. Click **OK** to make the printer hard disk and job-storage features available.

You can disable the job-storage feature while leaving the printer hard disk enabled. To disable the job-storage feature, follow these steps:

1. In Windows Vista and Windows 7, click the **Start** button, click **Control Panel**, click **Hardware and Sound**, and then click **Printers**.

In Windows XP, Windows Server 2003, and Windows Server 2008, click **Start**, click **Settings**, and then click **Printers and Faxes**.

2. Right-click the product name.
3. Click **Properties**.
4. Click the **Device Settings** tab.
5. Select **Job Storage**.
6. Select **Disabled** in the **Change 'Job Storage' Setting** dialog box that appears.

If the job-storage feature is enabled (without installing a hard disk but with at least 288 MB of total memory), two **Job Storage Mode** settings are available on the **Job Storage** tab:

- **Proof and Hold**
- **Personal Job**

Two additional **Job Storage Mode** settings become available on the **Job Storage** tab if a hard disk is installed:

- **Quick Copy**
- **Stored Job**

The following figure shows the **Job Storage** tab.

Figure 4-17 Job Storage tab

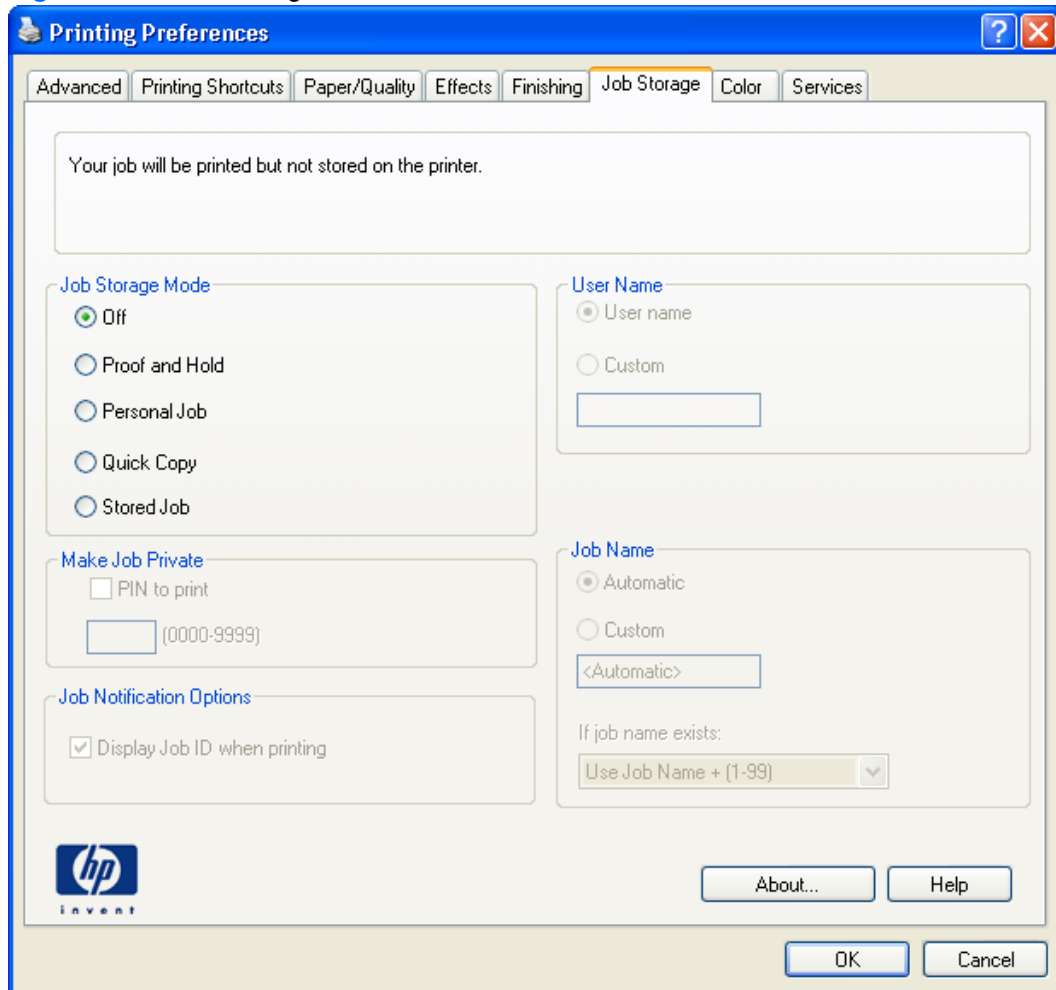

The **Job Storage** tab contains the following controls:

 **NOTE:** Information about using the job-storage feature when printing is also provided here.

- [Status group box](#)
- [Job Storage Mode](#)
- [PIN to print](#)

- [Job Notification Options](#)
- [User Name](#)
- [Job Name](#)
- [Use job-storage features when printing](#)

Status group box

The unlabeled group box on the **Job Storage** tab contains a status message about the destination of a print job. The status information changes depending on the selections that are made on the **Job Storage** tab.

Job Storage Mode

Use the **Job Storage Mode** options on the HP Color LaserJet Enterprise CP4020-CP4520 Series product to store documents at the product and then control their printing at the product control panel.

The HP Color LaserJet Enterprise CP4020-CP4520 Series product offers the following **Job Storage Mode** options:

- **Off**
- **Proof and Hold**
- **Personal Job**
- **Quick Copy**
- **Stored Job**

These options and the settings that control them are described below.

Off

When selected, this option turns the job-storage feature off (it is disabled), which means that the print job will not be stored in the product.

Proof and Hold

To use the **Proof and Hold** option, the job-storage feature must be enabled.

When selected, this option stores the print job in memory and prints only the first copy of the job, allowing you to check the first copy. If the document prints correctly, you can print the remaining copies of the print job at the control panel. You can set the number of proof-and-hold print jobs that can be stored in the product at the control panel.

After it is released for printing, the proof-and-hold job is immediately deleted from the product. If more copies are needed, you must reprint the job from the software program. If you send a second proof-and-hold job to the product with the same user name and job name as an existing proof-and-hold job (and you have not released the original job for printing), the job overwrites the existing job. Proof-and-hold jobs are deleted if you turn off the product.

 **NOTE:** The product configuration can be set to hold a maximum of 50 quick-copy or proof-and-hold jobs. The number is set at the product control panel in the **CONFIGURATION** menu, and the default is 32. When this preset limit is reached, the new document overwrites the oldest held document. Also, a document that has the same user name and job name as one that is already stored on the printer hard disk will overwrite the existing document.

Personal Job

To use the **Personal Job** option, the job-storage feature must be enabled.

When you select **Personal Job**, the print job is sent to the product, but is not printed until you request the job at the product control panel. Selecting **Personal Job** activates the **PIN** group box. If **PIN to print** is selected, the print job can be printed only after you type the correct PIN at the control panel. After the job is printed, the job is immediately deleted from the product. This feature is useful when you are printing sensitive or confidential documents that you do not want to leave in an output bin after printing.

The Private Job/PIN coupling has a PIN restriction of four ASCII numeric characters (0 through 9). If you type non-numeric characters, they are removed immediately. If you type more than four characters, the characters past the fourth are truncated. The field temporarily accepts fewer than four digits in the string, but when the edit field loses focus, the zeroes pad the left end until the PIN contains exactly four digits. The default initialized value for the PIN is 0000 for **Personal Job**.

After it is released for printing, the private job is immediately deleted from the product. If more copies are needed, you must reprint the job from the software program. If you send a second private job that has the same user name and job name as an existing private job (and you have not released the original job for printing), the job overwrites the existing job, regardless of the PIN. Private jobs are deleted if you turn off the product.

Quick Copy

To use the **Quick Copy** option, a printer hard disk must be installed, and the job-storage feature must be enabled.

When you select **Quick Copy**, the entire print job prints and a copy of the print job is stored on the product, after which you can print additional copies of the print job at the product control panel. The number of quick-copy print jobs that can be stored in the product is set by using the product control panel.

 **NOTE:** The product configuration can be set to hold a maximum of 50 quick-copy or proof-and-hold jobs. The number is set at the product control panel in the **CONFIGURATION** menu, and the default is 32. When this preset limit is reached, the new document overwrites the oldest held document. Also, a document that has the same user name and job name as one that is already stored on the printer hard disk will overwrite the existing document. **Quick Copy** jobs are deleted if you turn off the product.

Stored Job

To use the **Stored Job** option, a hard disk must be installed on the product and the job-storage feature must be enabled.

Use the **Stored Job** option to send a print job directly to the printer hard disk without printing it. The print job is stored in the product as if it is an electronic file cabinet. After the print job is stored on the printer hard disk, you can print the job at the product control panel.

The job remains stored in the product until it is deleted or overwritten by a document that has the same user name and job name. Stored jobs remain on the printer hard disk when the product is turned off. Use this feature for forms and other common or shared documents.

A stored job can be managed in two ways: as either a private or a public job.

Select the **PIN to Print** check box to set the private mode. Use a private stored job to send a print job directly to the product, which can then be printed only after you type a PIN up to 4 digits long at the product control panel. (You can set the PIN in the **PIN** group box.)

After the job is printed, the job remains in the product and can be printed again at the product control panel.

The box labeled **PIN** is usually inactive. The **PIN to Print** option becomes available when you select **Stored Job**. If you select the **PIN to Print** box, you must type a PIN to make the stored job private.

 **NOTE:** A *private* stored job is not the same as a *personal* job. *Personal* jobs are deleted from the product after they are printed. *Private stored* jobs are retained in the product after printing, but require that a PIN be typed each time they are printed. A printer hard disk is required for *Private stored* jobs.

PIN to print

PIN to print check box is available when **Stored Job** is selected. Select the **PIN to Print** box, then type a 4-digit PIN number in the box provided. The stored job is sent to the product, where you must enter the 4-digit PIN on the control panel to retrieve the personal job.

The **PIN to Print** check box is available when **Personal Job** is selected. Select the **PIN to Print** option, and then type a 4-digit PIN number in the box provided. The personal job is sent to the product, where you must type the 4-digit PIN on the control panel to retrieve the stored job.

Job Notification Options

Clicking a **Job Storage Mode** selection causes the **User Name** and **Job Name** options to become available. The **Display Job ID when printing** check box is selected by default. The **Display Job ID when printing** option causes a pop-up dialog box to appear when the job-storage print job is printed. The dialog box shows the user name and job name that are associated with the stored print job, as well as the printer name, port, and location.

User Name

Use the **User Name** settings to help identify the job at the product control panel. The following are the **User Name** settings:

- **User Name.** This option associates your Windows user name with the stored print job. The Windows user name automatically appears in the text field below the **User Name** options.
- **Custom.** Use this option to type a custom name for the stored print job. When you click **Custom**, the text field below the option becomes available. The **User Name** field can contain no more than 16 characters, and is limited to A through Z and 0 through 9 because the name appears on the product control-panel display. If you try to type a lowercase character, it automatically shifts to uppercase. If you try to type a character in an ASCII code of fewer than 32 or more than 126 characters, the character is removed from the edit field, along with all of the characters that follow it. If you try to type more than 16 characters, any character beyond 16 is truncated.

Job Name

Use the **Job Name** options to specify a name to identify the job at the product control panel. The following are the **Job Name** settings:

- **<Automatic>** This option, which is the default selection, automatically generates the job name that is associated with the stored print job. The file name of the print job is used if it is available to the print driver. Otherwise, the software program name or a time stamp is used for the job name.
- **Custom.** Use this to type a custom job name for the stored print job. When you click **Custom**, the text field below the option becomes available. In those languages for which **<Automatic>** cannot be translated without the use of invalid characters, the driver uses a string of three dashes. The acceptable characters for job name and user name vary for each operating system. The string must be of a length and type that can appear on the product control-panel display.

The **Job Name** field can contain no more than 16 characters, and is limited to A through Z (uppercase or lowercase) and 0 through 9 so that the name can appear on the product control-panel display. If you try to type a character in an ASCII code of fewer than 32 or more than 126 characters, the character is removed from the edit field, along with all of the characters that follow it. If you try to type more than 16 characters, any character beyond 16 is truncated.

When the dialog box is closed, or as soon as the focus is removed from the control (that is, when the **Tab** key is pressed or another control is selected), an empty string is replaced with **<Automatic>**. The acceptable characters for job name and user name vary for each operating system. The string must be of a length and type that can appear on the product control-panel display.

If Job Name Exists. When you store a print job, you can create a print-job name or the product software can assign one automatically. If a print job with the same name already exists, the new print job will overwrite the existing print job. To eliminate the chances of a new print job overwriting an old print job because both have the same name, select **Use Job Name + (1-99)**. After you create the print job name, or when one is created automatically, the product software assigns a number between 1 and 99 to the end of the print job name to make the name unique. Select **Replace Existing File** if you always want the product software to overwrite an existing print job with the same print job name.

Use job-storage features when printing

To use job-storage features when printing, follow these steps:

1. Click **File**, and then click **Print** from the software program. The **Print** dialog box appears.

 **NOTE:** Clicking the print icon in the software program toolbar prints the job without using job-storage features.

2. Click **Properties**. The **Properties** dialog box appears.
3. Click the **Job Storage** tab.
4. Select the job-storage options by clicking the appropriate option button, and then complete any required fields.
5. Click **OK**.

Release a job-storage print job

After you send a print job that uses the job-storage feature, you can release the job to print from the product control panel.

1. Press the **Home** button  to open the menus.
2. Press the **up arrow** ▲ or the **down arrow** ▼ until **RETRIEVE JOB** is highlighted on the product control panel, and then press **OK**.
3. Press the **up arrow** ▲ or the **down arrow** ▼ to scroll to your user name, and then press **OK**.
4. Press the **up arrow** ▲ or the **down arrow** ▼ to scroll to the job name, and then press **OK**.
5. Press the **up arrow** ▲ or the **down arrow** ▼ until **PRINT** is highlighted on the product control panel, and then press **OK**.
6. Press **OK**.
7. If a PIN number is assigned to the job, press the **up arrow** ▲ or the **down arrow** ▼ to select the first digit of the PIN, and then press **OK**. The number in the product control-panel display changes to an asterisk. Repeat this step for each of the remaining three digits of the PIN number.

If no PIN number is assigned to the job, continue with the next step.

8. Press the **up arrow** ▲ or the **down arrow** ▼ to select the number of copies to print.
9. Press **OK** to print the job.

Delete a job-storage print job

Sometimes it is necessary to delete a print job from the printer hard disk. You can do this from the product control panel.

1. Press the **Home** button  to open the menus.
2. Press the **up arrow** ▲ or the **down arrow** ▼ until **RETRIEVE JOB** is highlighted on the product control panel, and then press **OK**.
3. Press the **up arrow** ▲ or the **down arrow** ▼ to scroll to your user name, and then press **OK**.
4. Press the **up arrow** ▲ or the **down arrow** ▼ to scroll to the job name, and then press **OK**.
5. Press the **up arrow** ▲ or the **down arrow** ▼ until **DELETE** is highlighted on the product control panel, and then press **OK**.
6. Press **OK**.
7. If a PIN number is assigned to the job, press the **up arrow** ▲ or the **down arrow** ▼ to select the first digit of the PIN, and then press **OK**. The number in the product control-panel display changes to an asterisk. Repeat this step for each of the remaining three digits of the PIN number.

If no PIN number is assigned to the job, continue with the next step.

8. Press **OK** to delete the job.

Color tab features

 **NOTE:** The **Color** tab is located on the **Printing Preferences** tab set. For information about how to access these tabs, see [Printing Preferences driver tabs on page 101](#),

Use the **Color** tab to specify predefined color-option settings or to fine-tune the color treatments and halftoning. Color output can also be converted to grayscale. The **Color** tab is shown in the following figure.

Figure 4-18 Color tab

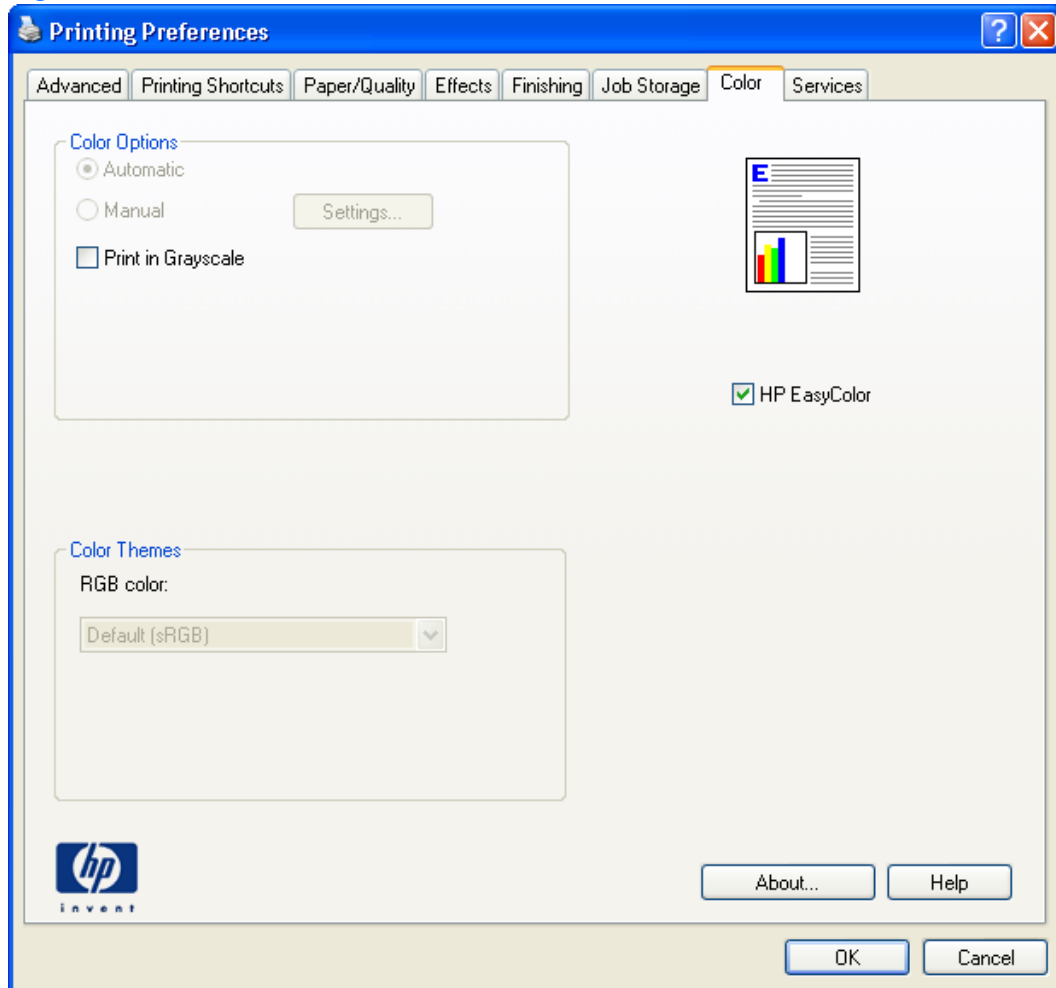

The **Color** tab contains the following sets of controls:

- [Color Options](#)
- [Color Themes](#)
- [Document preview image](#)
- [HP EasyColor](#)

Color Options

Use the **Color Options** group box to adjust the independent color controls. The settings affect the print job color rendering and print quality. The **Color Options** group box contains the following controls:

- **Automatic** option (default)
- **Manual** option
- **Settings** button (Click this button to open the **Color Settings** dialog box.)
- **Print in Grayscale** check box

Automatic

Use the **Automatic** option for color settings that automatically fine-tune the printed output. The **Automatic** color settings provide high-quality output while maintaining product performance for most color printing needs.

Manual

To change the color settings, select the **Manual** option, and then click **Settings**. The **Color Settings** dialog box appears.

To change the settings, make your selections by using the drop-down menus in the **Color Settings** dialog box, and then click **OK**. The following figure shows the **Color Settings** dialog box with "Custom" settings.

Figure 4-19 Color Settings dialog box

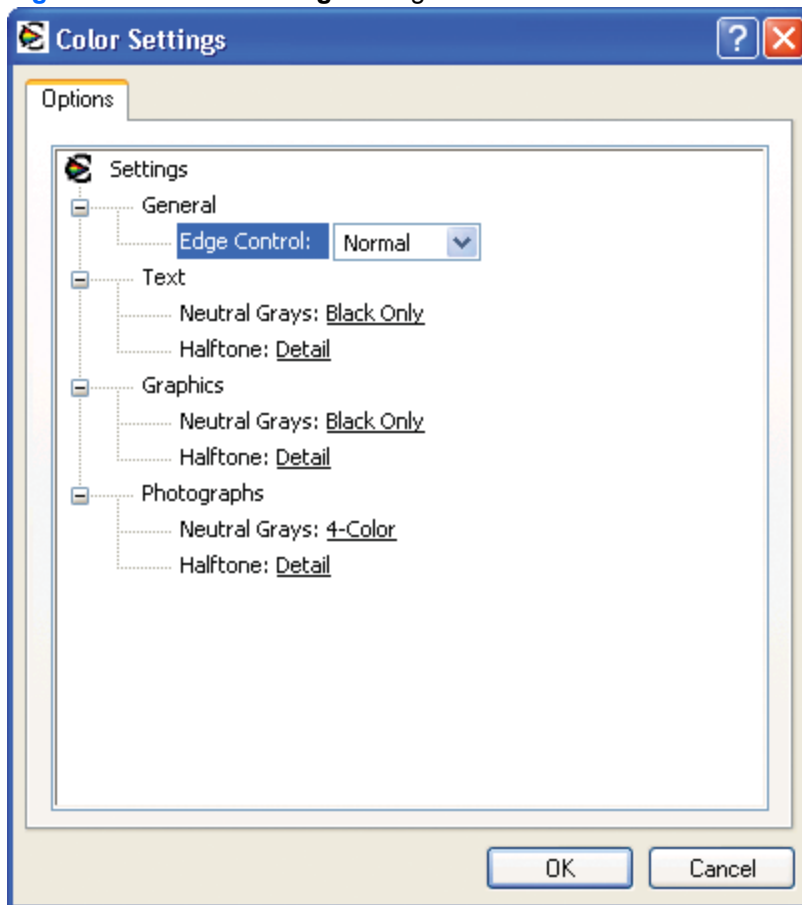

The **Color Settings** dialog box contains the following controls:

- **General**
 - **Edge Control**
- **Text**
 - **Neutral Grays**
 - **Halftone**
- **Graphics**
 - **Neutral Grays**
 - **Halftone**
- **Photographs**
 - **Neutral Grays**
 - **Halftone**

General

Use the **General** setting group to control **Edge Control** settings for all color printing.

Edge Control determines how edges are rendered. **Edge Control** consists of three components:

- Adaptive Halftoning, which increases edge sharpness
- Trapping, which reduces the effect of color plane misregistration by slightly overlapping the edges of adjacent objects
- Color Resolution Enhancement Technology (C-REt), which increases the apparent resolution by placing each dot for the smoothest edges

The **Edge Control** option offers four settings:

- **Off.** The **Off** setting turns Trapping, Adaptive Halftoning, and C-REt to **Off**.
- **Light.** The **Light** setting provides minimal trapping. Adaptive Halftoning is set to **On** and C-REt is set to **On**.
- **Normal.** The **Normal** setting provides the default trapping settings. Adaptive Halftoning is set to **On**, and C-REt is set to **On**.
- **Maximum.** The **Maximum** setting provides the most trapping. Adaptive Halftoning is set to **On**, and C-REt is set to **On**.

Neutral Grays

The **Neutral Grays** drop-down menu controls the selection of a device-dependent color table that is embedded in the product firmware. You can adjust the **Neutral Grays** setting independently for text, graphics, or photographs. The following options are available:

- **Black Only.** This option generates neutral colors (grays and black) by using only black toner. This option guarantees that neutral colors do not have a color cast. **Black Only** is the default setting for the **Text** and **Graphics** components.
- **4-Color.** This option generates neutral colors by combining all four colors of toner, which produces smoother gradients and transitions to non-neutral colors. It also produces the darkest possible black. **4-Color** is the default setting for **Photographs**.

Halftone

The **Halftone** setting controls the selection of a product-dependent halftone algorithm that is embedded in the product firmware. Halftoning is a method by which the product mixes the four primary colors (cyan, magenta, yellow, and black) in varying proportions to create the appearance of many colors. The **Halftone** options affect the resolution and clarity of the color on the printed page. You can select **Halftone** settings for text, graphics, and photographs independently.

The following Halftone options are available:

- **Detail.** This is the default option; it is useful for text and graphics that require sharp distinctions among lines or colors, or for images that contain a pattern or a high level of detail. Select this option for sharp edges and detail.
- **Smooth.** This option provides better results for large, solid-filled print areas. It also enhances photographs by smoothing out fine color gradations. Select this option for uniform and smooth area fills.

Color Themes

The **Color Themes** group box contains the following **RGB color** options, which determines how colors are rendered:

- [Default \(sRGB\)](#)
- [Photo \(sRGB\)](#)
- [Photo \(Adobe RGB 1998\)](#)
- [Vivid \(sRGB\)](#)
- [None](#)
- [Custom Profile](#)

Default (sRGB)

Select **Default (sRGB)** for most printing needs. This setting instructs the product to interpret RGB color as sRGB, which is the accepted standard of Microsoft and the World Wide Web Consortium (W3C). Colors are matched to optimize the RGB colors on the screen and to provide vivid images and graphics.

Photo (sRGB)

Select **Photo (sRGB)** to enhance documents in which the content is mainly bitmap images, such as .GIF or .eps files. This setting instructs the product to use the best color matching for rendering sRGB bitmap images. This setting affects only raster data; it has no effect on text or vector-based graphics. Using glossy paper in combination with this setting provides the maximum enhancement.

Photo (Adobe RGB 1998)

Select **Photo (AdobeRGB 1998)** for documents that use the AdobeRGB color space rather than sRGB. For example, some digital cameras capture images in Adobe RGB, and documents that are produced with Adobe PhotoShop use the Adobe RGB color space. When printing from a professional software program that uses Adobe RGB, it is important that you turn off the color management in the software program and allow the product software to manage the color space.

Vivid (sRGB)

The **Vivid (sRGB)** feature instructs the printer to increase the color saturation in the midtones. Less colorful objects are rendered more colorfully. This value is recommended for printing business graphics.

None

Select **None** to instruct the printer to print RGB data in raw device mode. To render documents properly when this option is selected, you must manage color in the program in which you are working or in the operating system.

△ **CAUTION:** Use this option only if you are familiar with the procedures for managing color in the software program or in the operating system.

Custom Profile

Select **Custom Profile** when you want to duplicate the printed output from other products or for using special effects. This setting instructs the product to use a custom profile to emulate color output from another product by modifying how color is rendered.

The default custom profile is an emulation of the color table used on the HP Color LaserJet 4650 product. The product holds only one custom profile at a time, so when you download and install another color table, it erases the default color table and installs the new one.

You can download custom profiles from the following Web site:

www.hp.com/go/cljcp4025_firmware or www.hp.com/go/cljcp4525_firmware

Document preview image

The document preview image is a line-drawn image of a page that represents graphics and text. The document preview image is always oriented so that the contents of the page are right-side-up. The document preview image appears in the upper-right corner of the following **Printing Preferences** driver tabs:

- **Printing Shortcuts**
- **Paper/Quality**
- **Effects**
- **Finishing**
- **Color**

Switching between tabs does not change the location or appearance of the document preview image. When you move the mouse over the document preview image, the mouse cursor changes from an arrow to a gloved hand. You can toggle between portrait and landscape page orientation by clicking the image.

HP EasyColor

If you are using the HP PCL 6 printer driver for Windows, the **HP EasyColor** technology automatically improves mixed-content documents that are printed from Microsoft Office programs. This technology scans documents and automatically adjusts photographic images in .JPEG or .PNG format.

HP EasyColor technology enhances the entire image at one time, rather than dividing it into several pieces, which results in improved color consistency, sharper details, and faster printing.

In the following example, the images on the left were created without using the **HP EasyColor** option. The images on the right show the enhancements that result from using the **HP EasyColor** option.



The **HP EasyColor** option is enabled by default in the HP PCL 6 printer driver, so you do not need to make manual color adjustments. To disable the option so you can manually adjust the color settings, open the **Color** tab, and click the **HP EasyColor** check box to clear it.

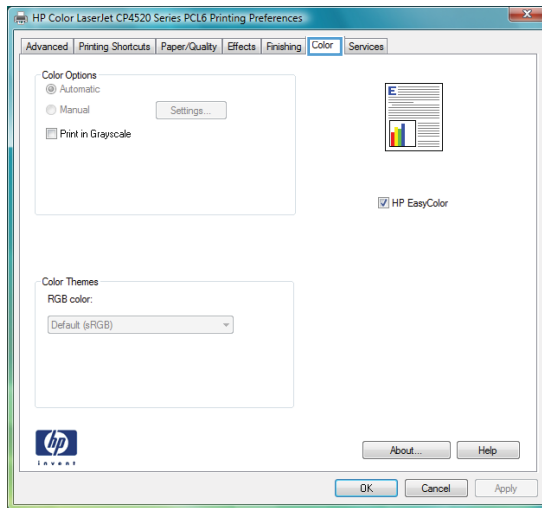

Services tab features

NOTE: The **Services** tab is located on the **Printing Preferences** tab set. For information about how to access these tabs, see [Printing Preferences driver tabs on page 101](#).

The **Services** tab is shown in the following figure.

Figure 4-20 Services tab

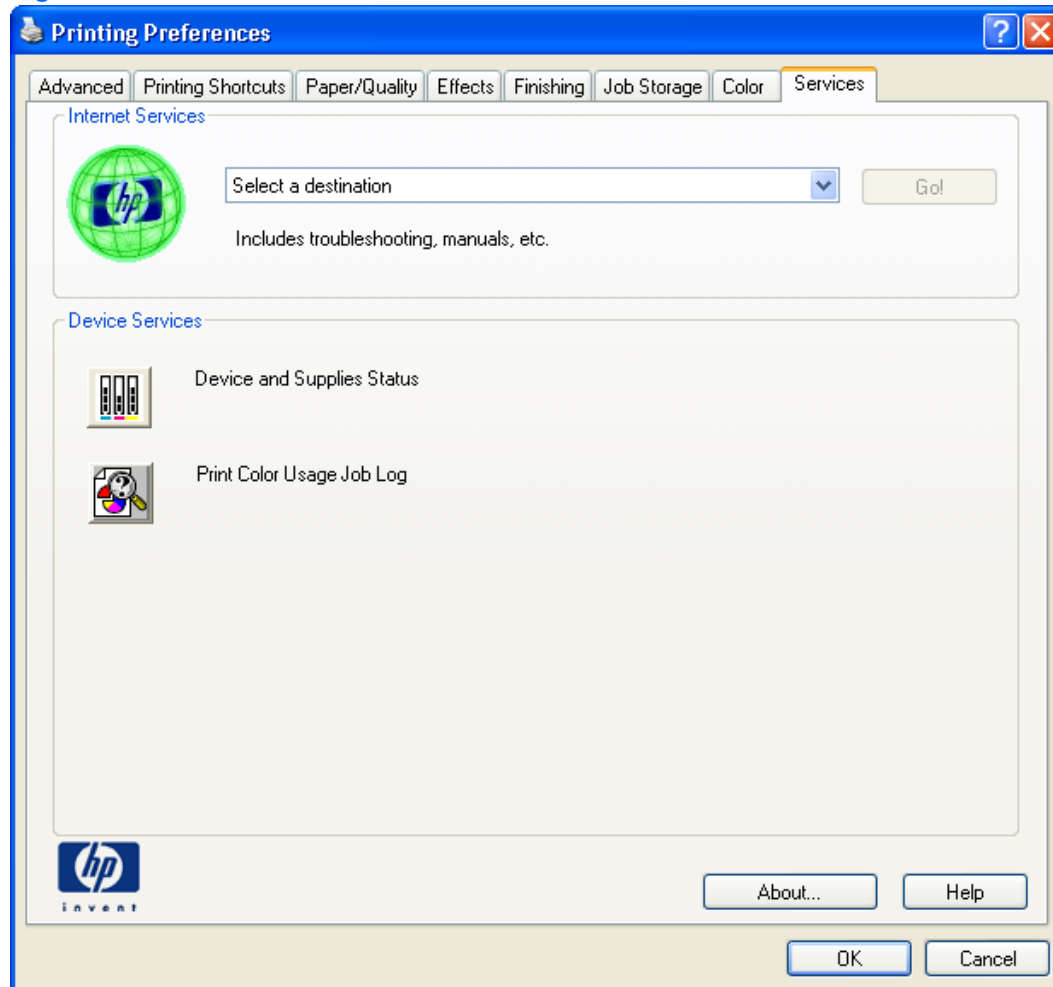

The **Services** tab contains the following group boxes:

- [Internet Services](#)
- [Device services](#)

Internet Services

The **Internet Services** group box contains the **Select a destination** drop-down menu with the following selections:

- **Online diagnostic tools.** This is the HP Instant Support Web site, where you can find interactive tools and contacts for troubleshooting.
- **Support and troubleshooting.** This is the main Web site for HP Color LaserJet Enterprise CP4020-CP4520 Series product support.

- **Product manuals.** View or download HP Color LaserJet Enterprise CP4020-CP4520 Series product manuals.
- **Check for driver updates.** Automatically check your print drivers to see whether the correct and most up-to-date print drivers are installed.
- **Color printing access/usage.** Find information about enabling and disabling color printing and tracking color print-job usage.
- **Shop for supplies.** Shop online for HP Color LaserJet Enterprise CP4020-CP4520 Series product supplies.

If you have Internet access, select any of these items and click **Go!** to open the corresponding HP Web page.

Device services

Click the **Device and Supplies** status icon to open the **Device Status** screen of the HP EWS, which shows supply levels and control panel status. For more information, see [HP Embedded Web Server on page 35](#).

Click the **Print color usage job log** icon to print a page that shows information about users, print jobs, and applications that have printed to the HP Color LaserJet Enterprise CP4020-CP4520 Series product.

Device Settings tab features

NOTE: The **Device Settings** tab is located on the **Properties** tab set. For information about how to access these tabs, see [Properties driver tabs on page 102](#),

Available options depend on the feature. The following figure shows the **Device Settings** tab.

Figure 4-21 Device Settings tab

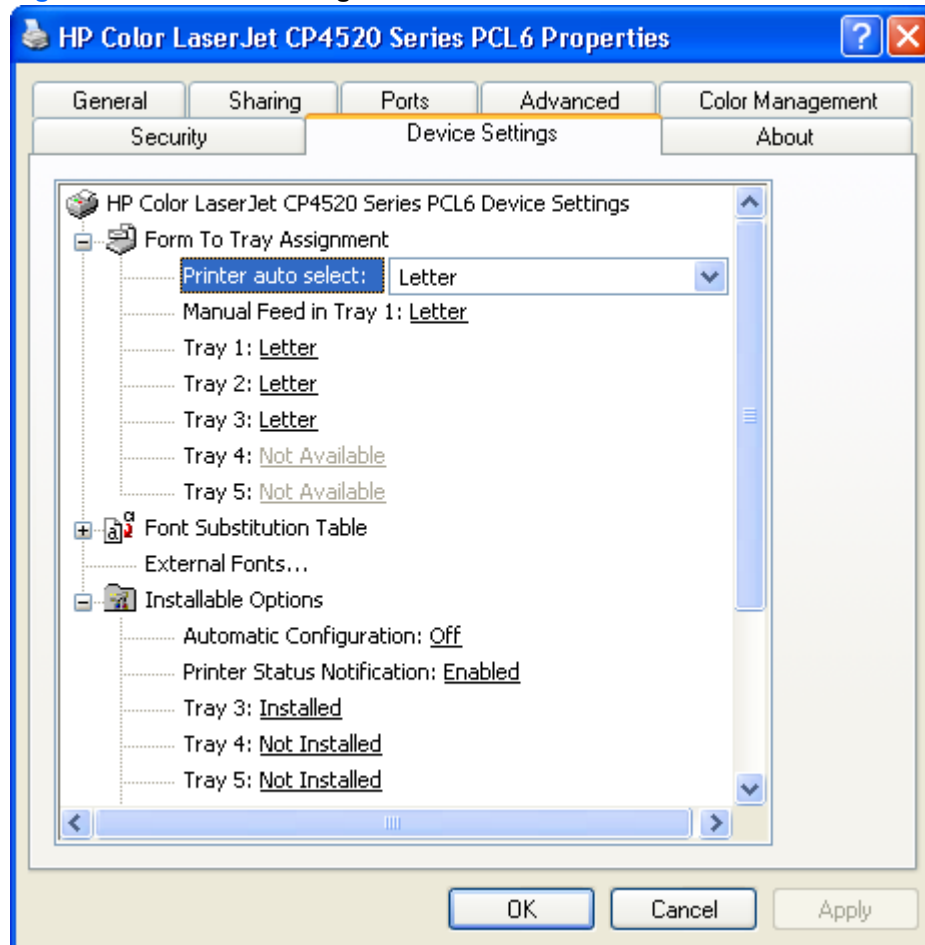

The **Device Settings** tab contains controls for paper-handling devices and controls for managing the HP Color LaserJet Enterprise CP4020-CP4520 Series product.

The **Device Settings** tab contains the following controls:

- [Form to Tray Assignment](#)
- [Font Substitution Table](#)
- [Installable Options](#)

Form to Tray Assignment

A network administrator can use **Form to Tray Assignment** to specify the paper size in each input tray.

The HP Color LaserJet Enterprise CP4020-CP4520 Series product supports more than one source of paper. You can assign a form (which defines the paper size and margins) to each paper source. When

a form is matched to a source, you can select the form when you print. The product prints from the tray to which that form is assigned.

Network administrators can use the **Form to Tray Assignment** setting to specify, in the driver, the paper size that is loaded into each available input tray. The use of forms constrains the choices that are available in the paper-size list on the **Paper/Quality** tab in the **Printing Preferences** driver tabs. This constraint prevents (or reduces the likelihood of) tying up the product with paper-mount messages that occur when users request sizes or types that are not available.

The trays listed in the **Form to Tray Assignment** setting include standard trays and optional accessory trays. Generally, items that are installed separately have a separate **Installable Options** setting.

The input trays listed here are also listed as paper sources on the **Paper/Quality** tab.

Configuring the trays

1. Select the appropriate tray in the **Form to Tray Assignment** list.
2. Use the drop-down menu to select the paper size (or form) that is loaded in that tray.
3. Repeat steps 1 and 2 for the remaining trays.
4. Click **OK** to enable your settings, or, if necessary, click **Cancel** to reconfigure all the trays, and remove the size and type constraints that have been imposed on the **Paper/Quality** tab.

Font Substitution Table

Use the **Font Substitution Table** settings to change the TrueType to printer font mapping and to install and remove external fonts for the product through the **External Fonts** option. External fonts can be soft fonts or DIMM fonts.

Click the **Font Substitution Table** option to open a list of fonts, as show in the following figure. Use the settings to change the TrueType-to-product font mappings.

Figure 4-22 Font Substitution Table

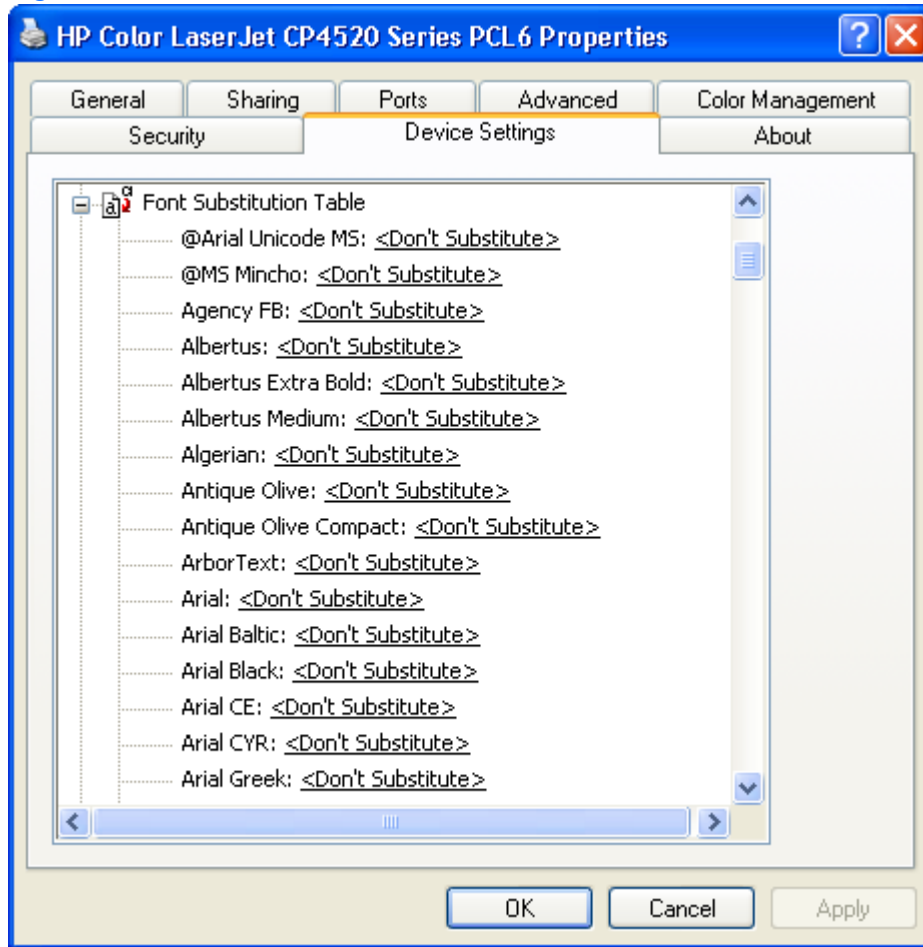

External Fonts

Use the **External Fonts** option to install and remove external fonts for the product. External fonts can be soft fonts or DIMM fonts.

Click the **External Fonts** option to make the **Properties** button available. Click **Properties** to open the **HP Font Installer** dialog box, which is shown in the following figure.

Figure 4-23 HP Font Installer dialog box

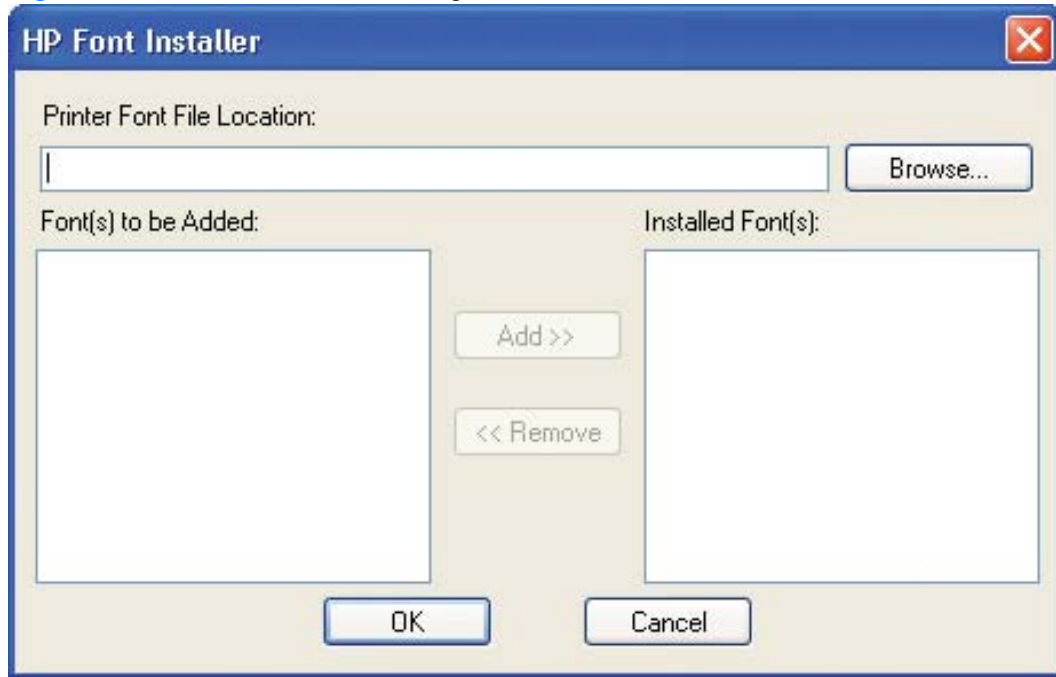

Installing external fonts

Follow these steps to install external fonts.

1. In Windows Vista and Windows 7, click the **Start** button, click **Control Panel**, click **Hardware and Sound**, and then click **Printers**.
In Windows XP, Windows Server 2003, and Windows Server 2008, click **Start**, click **Settings**, and then click **Printers and Faxes**.
2. Right-click the name of the product.
3. Click **Properties**.
4. Click the **Device Settings** tab.
5. Click the **External Fonts** option. The **Properties** button appears.
6. Click **Properties**. The **HP Font Installer** dialog box appears.
7. Type the name and path of the font metric file in the **Printer Font File Location** text box, or click **Browse** to locate the file on the computer. The font file names appear in the **Font(s) to be Added** window.
8. Select the fonts that you want to add, and then click **Add**. The fonts are installed and the file names appear in the **Installed Font(s)** window.
9. Click **OK** to close the **HP Font Installer** dialog box.

Removing external fonts

1. In Windows Vista and Windows 7, click the **Start** button, click **Control Panel**, click **Hardware and Sound**, and then click **Printers**.

In Windows XP, Windows Server 2003, and Windows Server 2008, click **Start**, click **Settings**, and then click **Printers and Faxes**.
2. Right-click the name of the product.
3. Click **Properties**.
4. Click the **Device Settings** tab.
5. Click the **External Fonts** option. The **Properties** button appears.
6. Click **Properties**. The **HP Font Installer** dialog box appears. The external fonts that are installed appear in the **Installed Fonts** window.
7. Select the fonts that you want to remove, and then click **Remove**. The fonts are removed.
8. Click **OK** to close the **HP Font Installer** dialog box.

Installable Options

Items under **Installable Options** are automatically populated and their defaults set when the driver is installed.

The HP Color LaserJet Enterprise CP4020-CP4520 Series product has printing options that you can install and configure in this section. The following controls are available:

- [Automatic Configuration](#)
- [Tray 3](#)
- [Tray 4](#)
- [Tray 5](#)
- [Duplex Unit \(for 2-Sided Printing\)](#)
- [Allow Manual Duplexing](#)
- [Printer Hard Disk](#)
- [Job Storage](#)
- [Job Separator](#)
- [Mopier Mode](#)

Automatic Configuration

Use the **Device Settings** tab to tell the driver about the hardware configuration of the product. If bidirectional communication is enabled in a supported environment, update this tab by selecting the **Update Now** setting in the **Automatic Configuration** setting. The default setting is **Off**. After an automatic configuration, the setting returns to **Off** after the changes are made.

If your environment does not support bidirectional communication, the **Update Now** setting is unavailable, so you must manually configure the options on this tab.

If you have more than one driver installed for the product (for example, the default HP PCL 6 Print Driver and the HP PCL 5 Universal Print Driver), the Update Now feature works automatically only on the driver on which it is activated. The other driver will not be updated, and might show the default setting for the specific product model.

Tray 3

This control specifies whether you have Tray 3, an additional 500-sheet tray, installed on the product. Tray 3 comes standard on the HP Color LaserJet CP4525xh product model, and is optional on the other HP Color LaserJet Enterprise CP4020-CP4520 Series models.

Tray 4

This control specifies whether you have Tray 4, an additional 500-sheet tray, installed on the product. Tray 4 comes standard on the HP Color LaserJet CP4525xh product model, and is optional on the other HP Color LaserJet Enterprise CP4020-CP4520 Series models.

Tray 5

This control specifies whether you have Tray 5, an additional 500-sheet tray, installed on the product. Tray 5 comes standard on the HP Color LaserJet CP4525xh product model, and is optional on the other HP Color LaserJet Enterprise CP4020-CP4520 Series models.

Duplex Unit (for 2-Sided Printing)

The duplexing unit comes installed on the HP Color LaserJet CP4525dn and the HP Color LaserJet CP4525xh product models.

 **NOTE:** The HP Color LaserJet Enterprise CP4020-CP4520 Series product supports smart duplexing. The product uses the smart duplexing feature to detect information on both sides of the print job pages and only runs the pages through the duplexing unit if printable information appears on the second side of the page.

Allow Manual Duplexing

Select **Allow Manual Duplexing** to print on both sides of any supported size and most types of paper (except transparencies, envelopes, and labels). To use this feature, you must reinsert the paper stack into the input tray to print the second side. The product pauses while you make this adjustment.

This setting is enabled by default.

Printer Hard Disk

When this option is installed, the **Job Storage** option and the **Mopier Mode** are enabled in the print driver. Use the **Job Storage** option to store print jobs and then print them later from the control panel. The multiple-original print (mopy) function is an HP-designed feature that produces multiple, collated copies from a single print job.

Job Storage

When **Job Storage** is enabled, the product can store print jobs so that you can gain access to those print jobs later at the control panel.

Job Separator

Use this control to specify whether a print job identifier page should be printed between print jobs.

Mopier Mode

The multiple-original print (mopy) function is an HP-designed feature that produces multiple, collated copies from a single print job. Multiple-original printing (mopying) increases performance and reduces network traffic by transmitting the job to the product once, and then storing it in memory or on the hard disk. The remainder of the copies are printed at the fastest speed. All documents that are printed in mopier mode can be created, controlled, managed, and finished from the computer, which eliminates the extra step of using a photocopier.

The HP Color LaserJet Enterprise CP4020-CP4520 Series supports the transmit-once mopying feature when the **Mopier Mode**: setting on the **Device Settings** tab is **Enabled**.

When you use the HP PCL 6 Print Driver, mopying is performed in one of two ways: either through the software or through the product hardware. When mopier mode is enabled, mopying takes place through the product hardware. One copy of a multiple-page print job is transmitted once through the network to the product, together with a printer job language (PJM) command directing the product to make the specified number of copies.

When you disable mopier mode, you are not necessarily disabling multiple collated copies, which the driver can still perform through the software rather than the product hardware (the mopying path that is disabled when you change the **Mopier Mode** setting to **Disabled**). However, a multiple-copy print job that is sent when the mopier is disabled loses the advantage of transmitting the print job once, because the job is sent through the network for each collated copy.

Mopier mode and collation

Mopying and collating print jobs are independent but closely related functions. Mopying, the ability to send original print jobs to the product, is performed by the print driver. Collating can be controlled by either the print driver or the document software program. The mopying mode is selected by default in the driver, and can be disabled by changing the **Mopier Mode** setting on the **Device Settings** tab to **Disabled**.

Control collation through the print driver by selecting or clearing the **Collated** check box on the **Advanced** tab. Click **Copy Count** under the **Paper Output** setting. You can clear the check box, which is available only when the **Copy Count** option is set to more than 1 copy, to allow the software program to control collation.

To receive uncollated multiple copies of a print job, you must clear the **Collated** check box *and* make sure that the software program collation feature is not selected.

The following table shows the relation between mopier mode settings and collation settings in the software program and the driver. The first three columns show the settings; the last column, "Expected result", shows how a 3-page print job would appear.

Table 4-4 Driver mopier mode and collation settings

Mopier mode	Application collation	Driver collation	Expected result
Disabled	Not selected	Not selected	3 copies uncollated
Disabled	Not selected	Selected	3 copies uncollated
Disabled	Selected	Not selected	3 copies collated
Disabled	Selected	Selected	3 copies collated
Enabled	Not selected	Not selected	3 copies uncollated
Enabled	Not selected	Selected	3 copies uncollated

Table 4-4 Driver mopier mode and collation settings (continued)

Mopier mode	Application collation	Driver collation	Expected result
Enabled	Selected	Not selected	3 copies collated
Enabled	Selected	Selected	3 copies collated

About tab features

 **NOTE:** The **About** tab is located on the **Properties** tab set. For information about how to access these tabs, see [Properties driver tabs on page 102](#).

The **About** tab provides detailed information about driver component versions. It contains an overall build version number (in parentheses after the model name) together with specific information about each of the components. The information varies according to the HP Color LaserJet Enterprise CP4020-CP4520 Series model number, driver, date, and versions. The **About** tab is shown in the following figure.

Figure 4-24 About tab

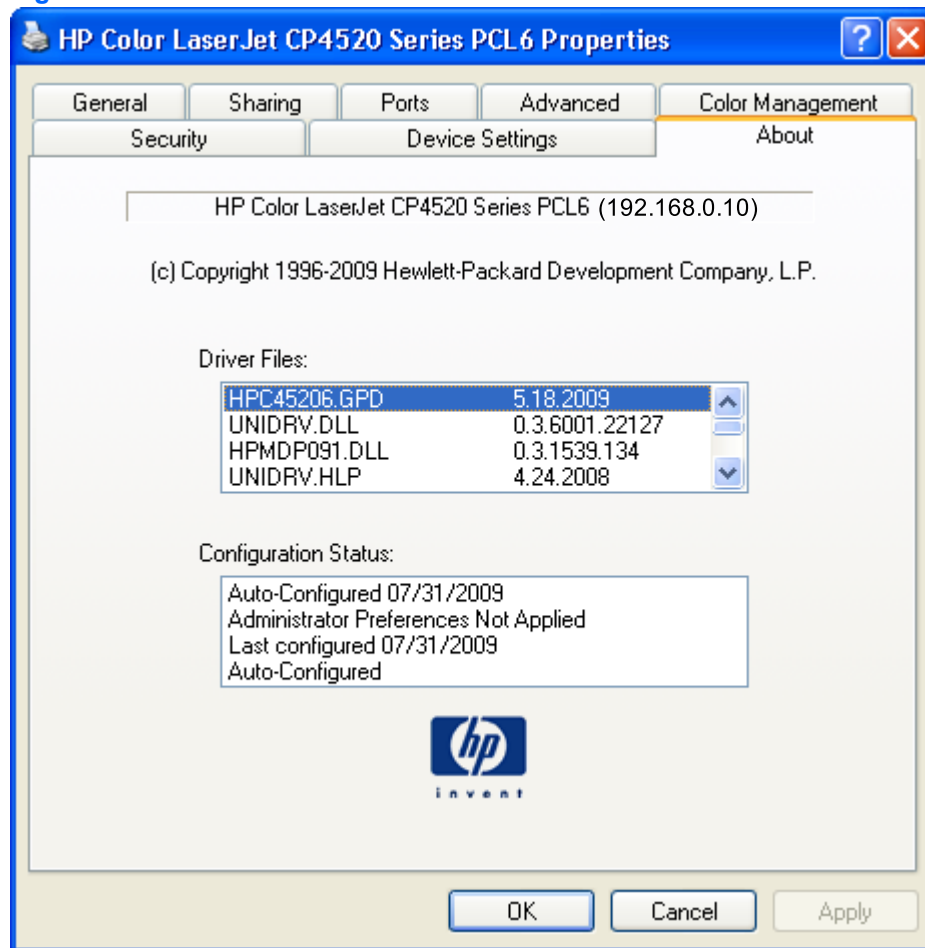

The **About** tab lists driver installation file names and their version numbers. The **About** tab also indicates whether the driver was autoconfigured, whether administrator preferences were set, the date the driver was last configured, and whether the configuration is autoconfigured or user-configured.

The **About** button is also available on most driver screens. The **About** button provides a driver version number and creation date.

5 Macintosh software and utilities

Introduction

The HP Color LaserJet Enterprise CP4020-CP4520 Series comes with software and installers for Apple, Inc. Macintosh systems.

This chapter provides procedures for installing and removing the HP Color LaserJet Enterprise CP4020-CP4520 Series printing-system software for Macintosh operating systems, as well as descriptions about the software and utilities. The chapter provides information about these topics:

- [Supported operating systems for Macintosh](#)
- [Printing-system software](#)
- [Macintosh installation instructions](#)
- [Remove software from Mac operating systems](#)
- [HP Printer Utility for Mac](#)

Supported operating systems for Macintosh

The product supports the following Mac operating systems:

- Mac OS X 10.4, 10.5, 10.6, and later

 **NOTE:** For Mac OS X 10.4 and later, PPC and Intel® Core™ Processor Macs are supported.

Macintosh system requirements



Hardware requirements

- PowerPC G3, G4, G5 or Intel Core processor
- 256 MB RAM
- 32 MB of available hard-disk space
- CD-ROM drive or Internet connection

Supported printer drivers for Mac

The HP LaserJet software installer provides PostScript® Printer Description (PPD) files, Printer Dialog Extensions (PDEs), and the HP Utility for use with Mac OS X computers. The HP printer PPD and PDE files, in combination with the built-in Apple PostScript printer drivers, provide full printing functionality and access to specific HP printer features.

Change printer-driver settings for Mac

Change the settings for all print jobs until the software program is closed	Change the default settings for all print jobs	Change the product configuration settings
<ol style="list-style-type: none">1. On the File menu, click the Print button.2. Change the settings that you want on the various menus.	<ol style="list-style-type: none">1. On the File menu, click the Print button.2. Change the settings that you want on the various menus.3. On the Presets menu, click the Save As... option and type a name for the preset. <p>These settings are saved in the Presets menu. To use the new settings, you must select the saved preset option every time you open a program and print.</p>	<p>Mac OS X 10.4</p> <ol style="list-style-type: none">1. From the Apple menu , click the System Preferences menu and then click the Print & Fax icon.2. Click the Printer Setup button.3. Click the Installable Options menu. <p>Mac OS X 10.5 and 10.6</p> <ol style="list-style-type: none">1. From the Apple menu , click the System Preferences menu and then click the Print & Fax icon.2. Select the product in the left side of the window.3. Click the Options & Supplies button.4. Click the Driver tab.5. Configure the installed options.

Printing-system software

The product includes the following software for Macintosh computers:

- PDEs for Mac OS X only (v10.4, v10.5, and later)

PDEs

Printer Dialog Extensions (PDEs) are code plug-ins that provide access to product features, such as number of copies, duplexing, and quality settings. The PDEs are HP additions to Apple's print driver.

HP Embedded Web Server

Mac OS X v10.4 and later support the HP Embedded Web Server (HP EWS). Use the HP LaserJet Utility to control features that are not available in the driver. Use the HP EWS to perform the following tasks:

- Name the product and assign it to a zone on the AppleTalk network.
- Change product settings.
- Set a password for the product.
- From the computer, lock out functions on the control panel to prevent unauthorized access (see the printing-software help).

Install notes

This text file contains important information about product features, instructions for installing the printing-system software, and technical assistance.

Online help

This HTML-based help system replaces the Apple Guide help system that was provided with Mac OS 9.x HP products. The help system is in English only, and can be viewed through a browser or in the Macintosh OS Help Center.

Screen fonts

The printing-system software for Macintosh operating systems no longer includes a font installer. The HP Color LaserJet Enterprise CP4020-CP4520 Series product uses previously installed system fonts when it is installed on a Macintosh computer.

Macintosh installation instructions

On a Macintosh computer, the installation procedures are basically the same for a network administrator, a network client, and a single user. Install the software on any computer that has save rights to the product. Users must have Administrator rights to install the software.

 **NOTE:** If the computer is connected to the product by a LocalTalk (printer port) connection, you must configure the AppleTalk (or network) control panel for the correct connection to communicate with the product. You must set up the HP Color LaserJet Enterprise CP4020-CP4520 Series, connect it to the computer or network, and turn it on *before* the software is installed. Macintosh operating systems do not support parallel connections.

The Macintosh partition contains an installer program for each language. Find the appropriate language for the operating system that is being used, and then use the installer program for that language.

 **NOTE:** Detailed installation steps can be found in [Mac OS X installation on page 171](#).

HP LaserJet software CD, Macintosh partition

The files contained in the Macintosh partition of the HP LaserJet software CD are grouped by language and reside in the following directory:

- HP CLJ CP4025.mpkg or HP CLJ CP4525.mpkg (installer for the Mac OS X operating system)
- Documentation

 **NOTE:** File layouts differ by language for each regional version of the software CD.

Install the HP LaserJet printing-system software for the Macintosh OS

Topics:

- [General installation instructions](#)
- [Mac OS X installation](#)
- [Setup instructions](#)

General installation instructions

1. Insert the Macintosh printing-system software CD into the CD-ROM drive.

 **NOTE:** If the CD screen does not open automatically, double-click the CD-ROM icon on the desktop to open the CD-ROM window.

2. Double-click the .mpkg icon.
3. Follow the onscreen instructions to complete the software installation.

 **NOTE:** If you are installing the printing-system software on a Macintosh OS X system, be patient. The installer must perform an initial search of the computer for up to 1 minute. During this time the installer might appear to be stalled.

4. When software installation is complete, click **Quit**. Use the following chart to finish setting up the product:

The software program that you use to finish setting up the product varies by operating system. The following table shows the print setup tools that are available.

Table 5-1 Adding a product in Macintosh operating systems

Operating System	Print Center	Printer Setup Utility
Mac OS X v10.4	x	x
Mac OS X v10.5	x	x

Mac OS X installation

This section provides information about the various installation dialog-box sequences for the Mac OS X operating system.

Main Install dialog box sequence

 **NOTE:** If you are connecting the product to a network, connect the network cable to the network port. If you are connecting the product to a computer by using the USB cable, install the software *before* connecting the USB cable.

1. Insert the HP Color LaserJet Enterprise CP4020-CP4520 Series printing-system software CD in the CD-ROM drive.

 **NOTE:** If the CD screen does not open automatically when the CD is put into the CD-ROM drive, double-click the CD-ROM icon on the desktop to open the installer folder.

2. The installer program opens.

Figure 5-1 Mac installer opening screen

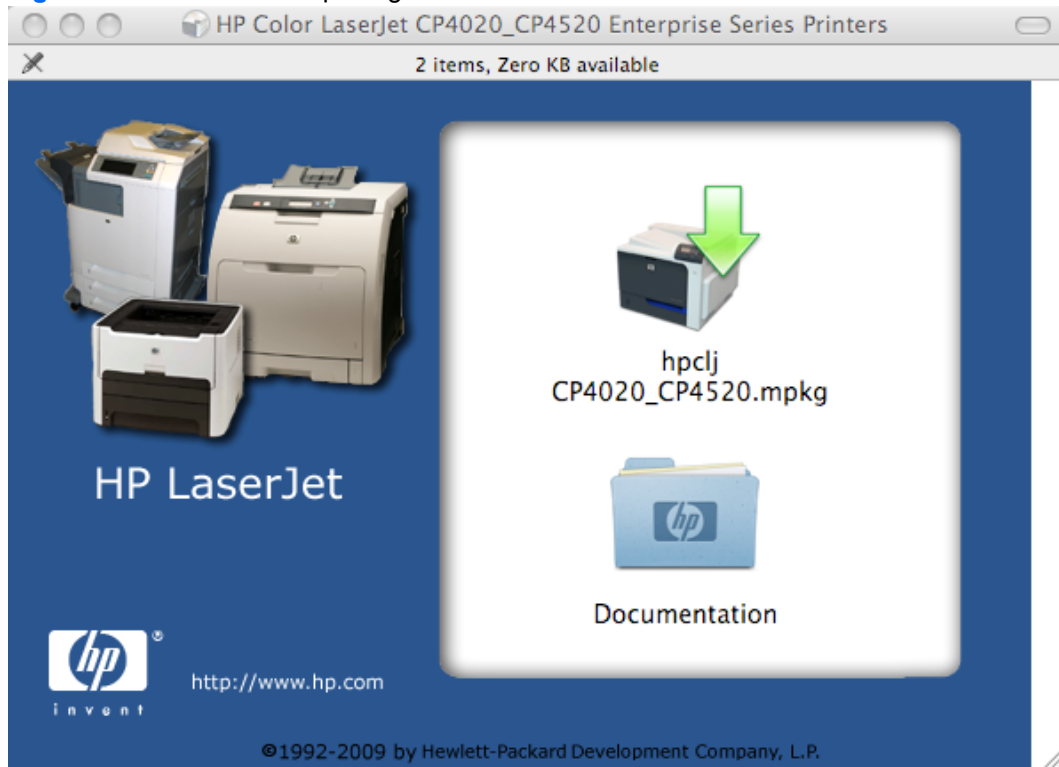

 **NOTE:** The file name displayed on your HP LaserJet installer browser screen may be different than the file name displayed in the above figure.

NOTE: In the HP LaserJet installer browser screen, double-click the **Documentation** icon to gain access to the product manuals. Select a language folder and locate the available guides which are in .PDF format. The user guide is a .PDF file that is named CP4025_use_enww.pdf or CP4525_use_enww.pdf.

3. In the HP LaserJet installer browser screen, double-click the product .MKPG icon to open the installer program Introduction dialog.

Figure 5-2 Mac installer Introduction dialog

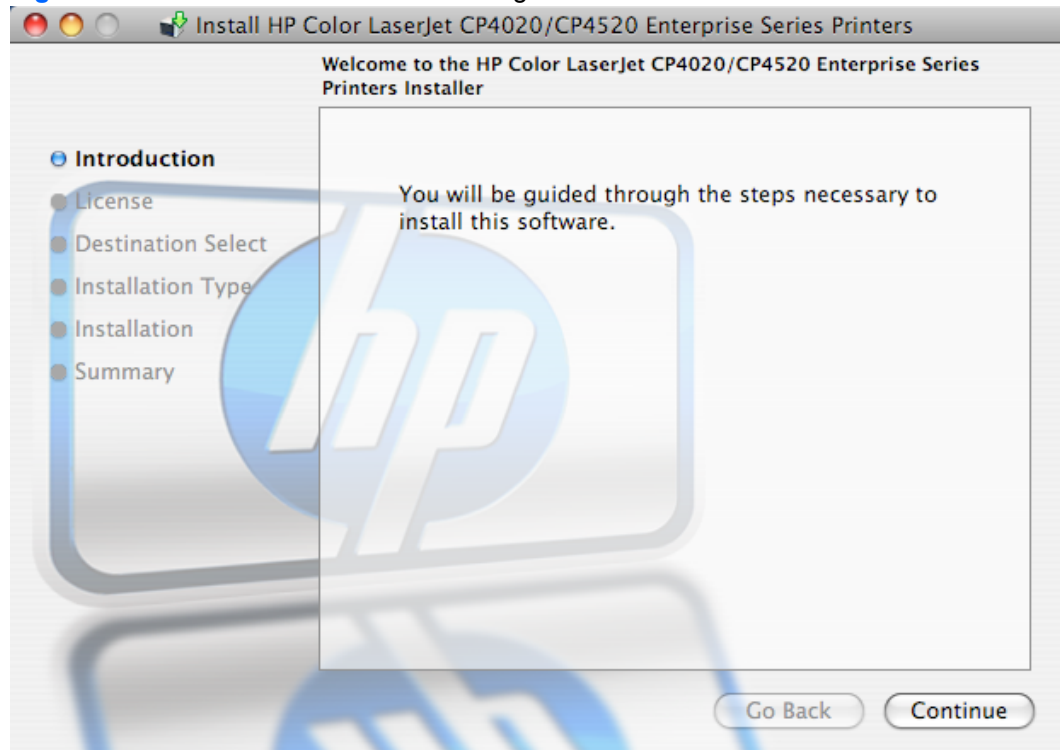

4. Click the **Continue** button. The License dialog appears.

Figure 5-3 Mac installer License dialog

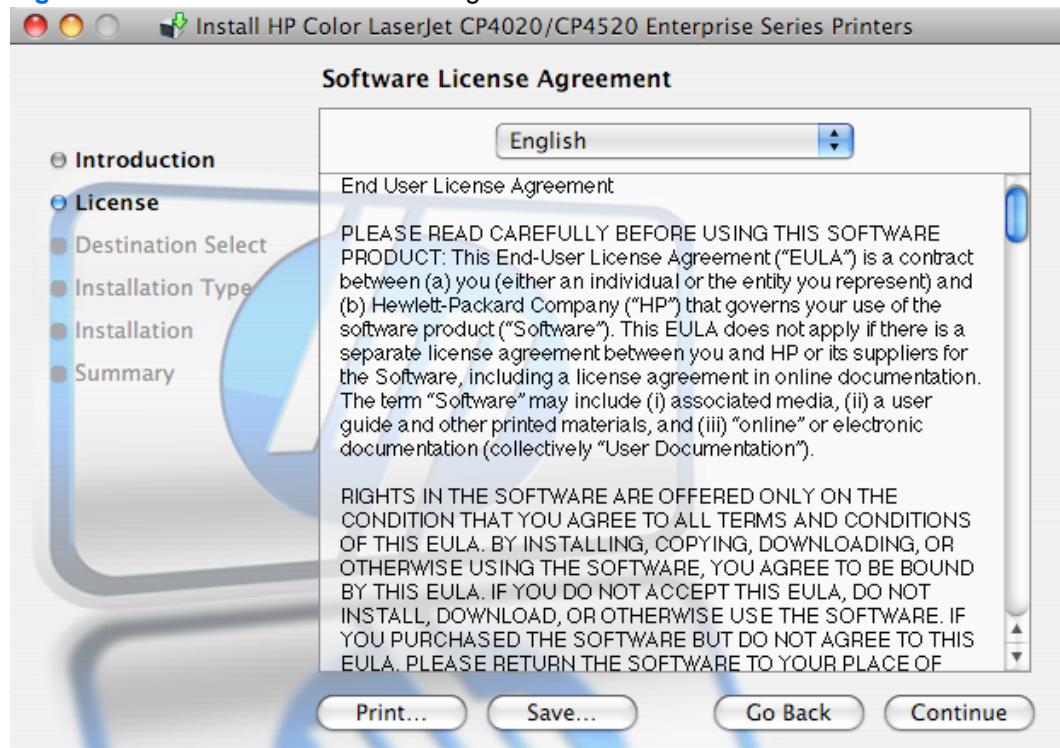

5. You can save or print the license file by clicking the **Save** button or the **Print** button.
6. Read the software license agreement, and then click the **Continue** file. The license agreement dialog appears.

Figure 5-4 Mac installer license agreement dialog

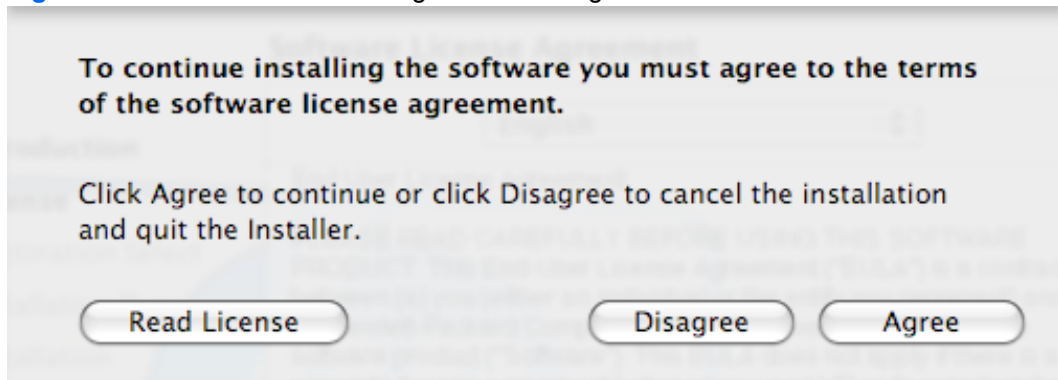

7. Click the **Disagree** button to end the installation and close the installer, or click the **Agree** button to continue the installation. The Installation Type dialog appears.

Figure 5-5 Mac installer Installation Type dialog

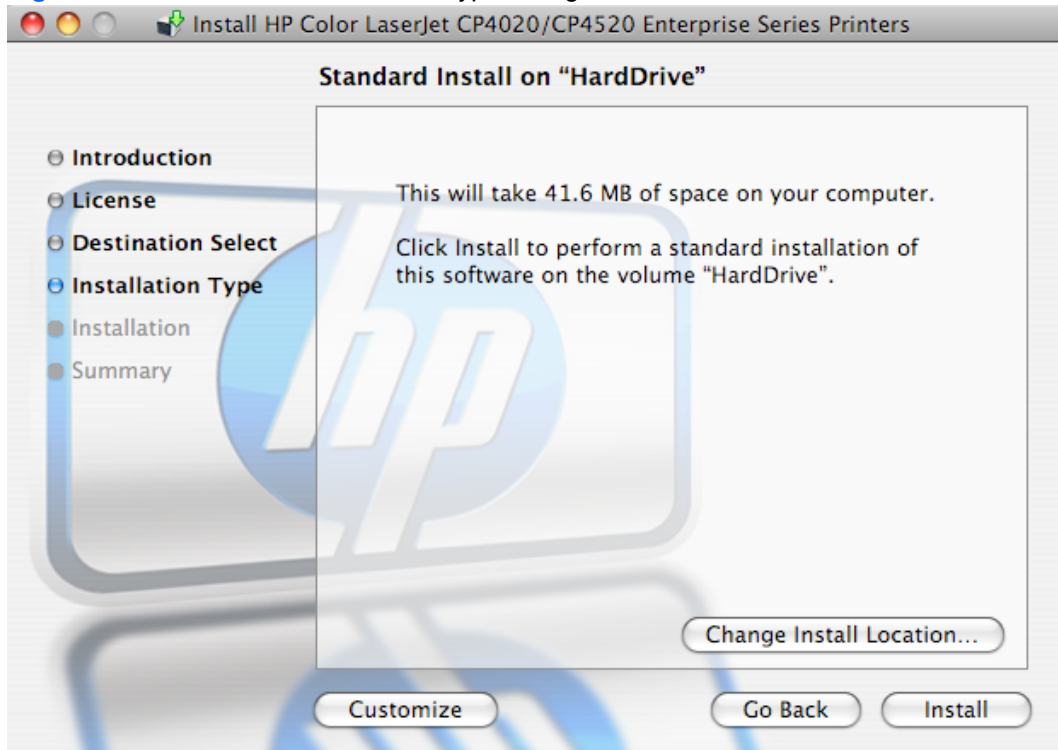

8. Click the **Go Back** button to go back to the previous screen.

To change the installation location, click the **Change Install Location** button, navigate to the desired location, click the **Continue** button, and then click the **Install** button. Go to step 9.

Click the **Install** button to continue the standard installation. Go to step 9.

Click the **Customize** button to open a dialog that lists separate software programs that you can choose to install.

Figure 5-6 Mac installer custom installation dialog

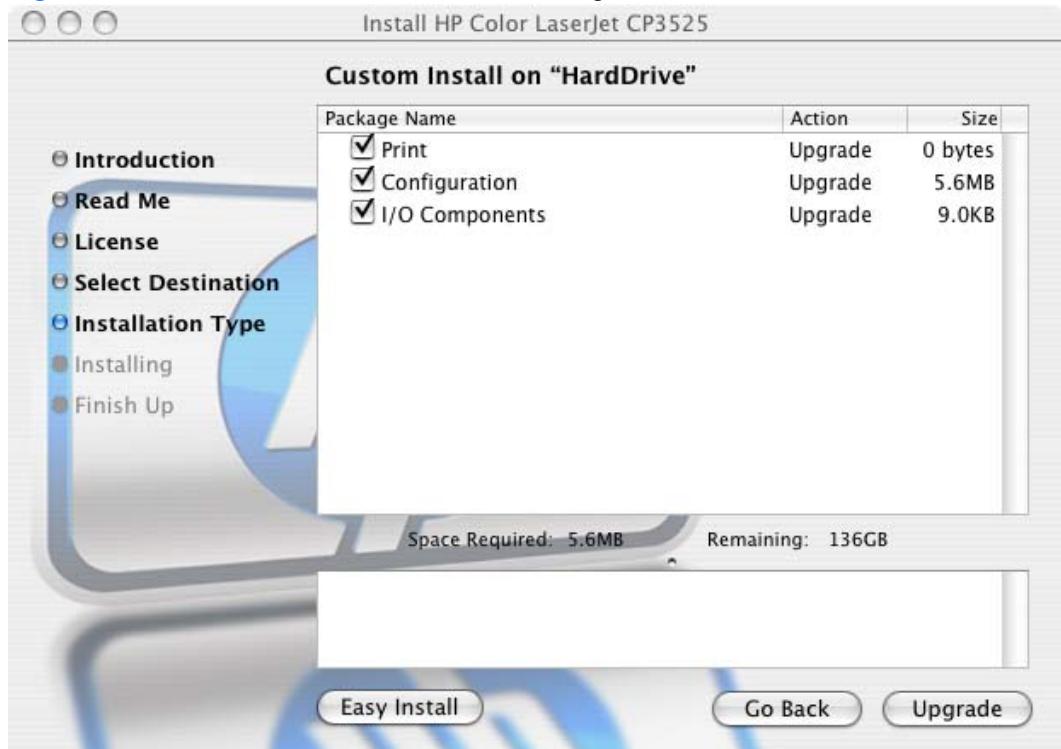

Click the **Standard Install** button to revert to the standard installation process.

Click **Go Back** to go back to the previous dialog box.

Use the check boxes in the **Package Name** list to select the printing-system components to install, and then click the **Install** button.

- An authentication dialog appears. Type the required user name and password, and then click the **OK** button.

Figure 5-7 Mac installer authentication dialog



- The Installation dialog appears. A progress bar shows the percentage of the installation progress that has been completed. Allow the program to install the software.

Figure 5-8 Mac installer Installation dialog

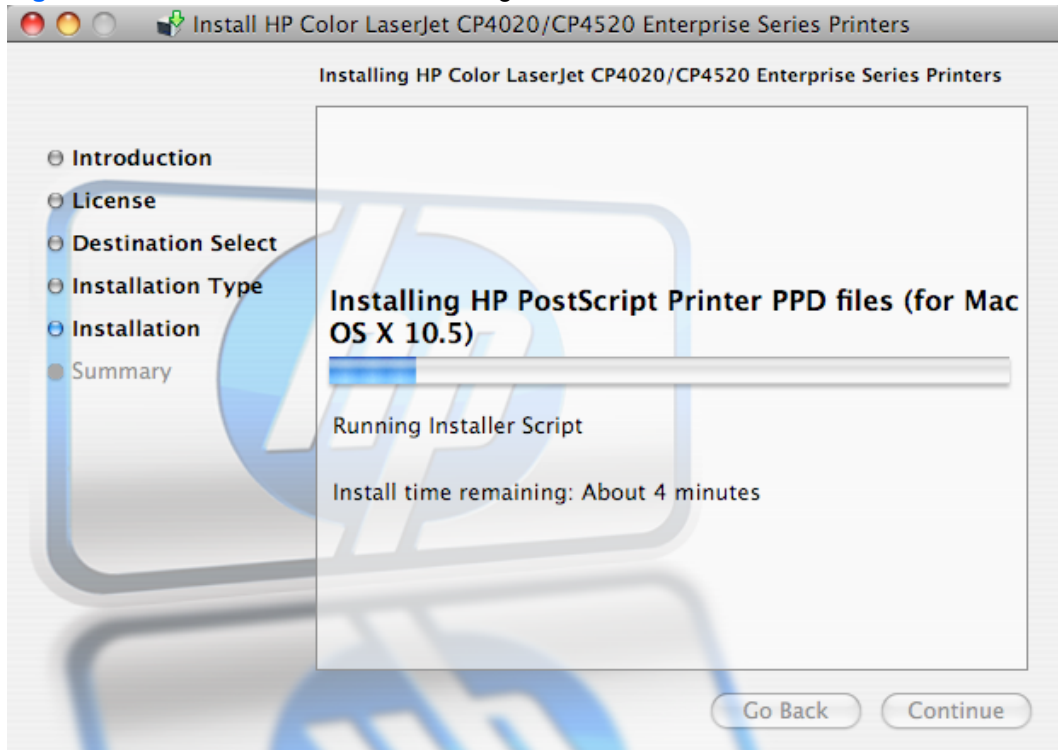

11. When the installation is complete, the **Summary** dialog appears, stating that the installation was successful.

Figure 5-9 Mac installer Summary dialog

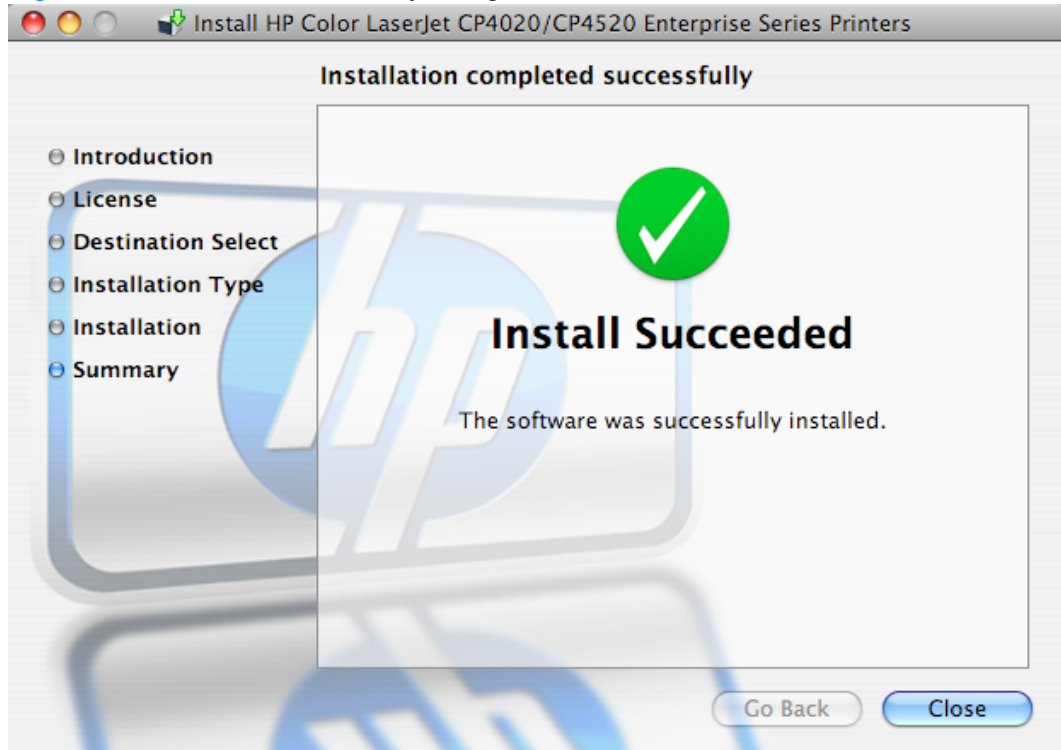

Click the **Close** button to exit the installer.

 **NOTE:** Complete the instructions in [Setup instructions on page 177](#) to set up a printer queue for your HP Color LaserJet Enterprise CP4020-CP4520 Series product.

Setup instructions

This section contains information about the following topics:

- [Setting up a printer with Mac OS X v10.4, v10.5, and later](#)
- [Troubleshooting the product setup](#)

Setting up a printer with Mac OS X v10.4, v10.5, and later

Complete these steps *after* completing the printing-system software installation.

1. If you are installing the product using a USB connection, connect the USB cable between the product and the computer. Turn on the product. If you are installing using a network connection, verify that the network cable is connected to the product and that the product is on.
2. In the **Applications** folder (in the **Finder** utility), open the **Utilities** folder, and then run the **Printer Setup Utility**.
3. If you are installing the product using a USB connection, verify that the product appears in the printer list. The **Name** column in the printer list should display the product name. If this is the case, the USB setup is complete.

If the product does not appear, or if the correct information does not appear in the field, see [Troubleshooting the product setup on page 179](#).

If you are installing the product using a network connection, continue with the following steps.

4. Click **Add** in the **Printer List** to open the **Printer Browser** screen.
5. You can use either Bonjour (default browser) or IP Printing for the network connection.

 **NOTE:** Bonjour is the easiest method and is the best method to use if the product is installed on your local network.

IP Printing *must* be used if you are installing the product on a different network.

If you are using Bonjour, carry out the following steps:

- a. Click the **Default Browser** tab.
- b. Select the product from the list. The software verifies that the product is connected to the network and the **Print Using** field is automatically populated with the correct PPD for the product.

 **NOTE:** If you are on a network that has more than one product, print a configuration page and match the Bonjour Printer Name to the name on the list to identify the product that you are installing.

NOTE: If the product does not appear in the list, verify that the product is on and connected to the network, then try turning the product off and then on again. If the product PPD does not appear in the **Print Using** pull-down list, turn the computer off and then on again, then restart the setup process. For more troubleshooting information, see [Troubleshooting the product setup on page 179](#).

- c. Click the **Add** button.
- d. Verify or select the appropriate **Installable Options**, and then click **Continue**. Select **Make Default** to set the device as your default.

You are finished with the setup process.

If you are using the IP Printing method, carry out the following steps:

- a. Click the **IP Printer** tab.
- b. Choose **HP Jet Direct – Socket** from the **Protocol** pull-down menu. This is the recommended setting for HP products.
- c. Follow these steps to print the configuration pages.
 - i. Press the **Home** button  to open the menus.
 - ii. Press the **up arrow** ▲ or the **down arrow** ▼ to scroll to **INFORMATION**, and then press **OK**.
 - iii. Press the **up arrow** ▲ or the **down arrow** ▼ to scroll to **PRINT CONFIGURATION**.
 - iv. Press **OK** to print the configuration page.

- d. On the first configuration page, under **IPv4**, find the IP Address. Type this address into the **Address** field on the add printer screen.
 - e. The **Name**, **Location**, and **Print Using** information will automatically be filled in. If the product PPD does not appear in the **Print Using** field, turn the computer off and then on again and restart the setup process.
6. Select the product and click **Add**. The **Installable Options** screen appears.
 7. In the **Optional Trays:** drop-down menu, select the trays that are installed on the product.
 8. In the **Collation in Printer:** drop-down menu, select the amount of memory and hard disk combination that is installed in the product:
 9. If the product has a hard disk, select **Installed** from the **Printer Hard Disk** drop-down menu.
 10. If the product has a duplex unit, select the **Duplex Unit** check box.
 11. In the **Accessory Output Bins:** drop-down menu, select the output bins that are installed on the product.
 12. In the **Paper Matching:** drop-down menu, select one of the following options:
 - **Prompt User for correct size**
 - **Nearest Size & Scale**
 - **Nearest Size & Crop**
 13. After you have selected the settings in the **Installable Options** screen, click **Continue**. The product name appears in the **Printer List** and the setup is complete.

Troubleshooting the product setup

If the product does not appear in the printer list after an installation:

Complete each one of these solutions in the order given, and restart the setup process after each one to see if the issue has been resolved.

- Verify that the USB or network cable is connected between the product and the computer and that the product is powered on.
- Try disconnecting and reconnecting the cable. If the computer has more than one USB port, try a different USB port.
- Turn the product off and then back on.
- Turn the computer off and then back on.
- If you are using a USB hub on the computer, disconnect any other USB devices from the hub.

If the wrong PPD appears in the Kind column in the printer list after installation:

1. Unplug the USB cable.
2. Delete the print queue with the incorrect type (for example, Generic PostScript Printer).
3. Reinstall the printing-system software.

4. Turn the computer off and then on.
5. Reconnect the USB cable from the computer to the product.

If these steps do not resolve the problem, delete the incorrect print queue, click **Add**, choose the product from the list, and then browse manually for the product PPD.

Remove software from Mac operating systems

You must have administrator rights to remove the software.

1. Open **System Preferences**.
2. Select **Print & Fax**.
3. Highlight the product.
4. Click the minus (-) symbol.
5. Delete the print queue, if necessary.
6. Delete the .GZ file from the following hard-drive folder:
 - **Mac OS X 10.4:** `Library/Printers/PPDs/Contents/Resources/<lang>.lproj`, where <lang> is the two-letter language code for the language that you are using.
 - **Mac OS X 10.5 and 10.6:** `Library/Printers/PPDs/Contents/Resources`

HP Printer Utility for Mac

The HP Printer Utility is a software program that gives you access to the product in Mac OS X.

The HP Printer Utility does not work when it is installed by using the AppleTalk protocol. Use IP, Bonjour or Rendezvous to enable the HP Printer Utility.

The following topics are discussed:

- [Access to the HP \(Printer\) Utility](#)
- [Supplies Status](#)
- [Device Information](#)
- [Color Usage](#)
- [File Upload](#)
- [Remote firmware update by using the HP Printer Utility](#)
- [Upload Fonts](#)
- [Duplex mode](#)
- [Trays Configuration](#)
- [Stored Jobs](#)
- [E-mail Alerts](#)
- [Network Settings](#)
- [Supplies Management](#)
- [Protect Direct Ports](#)
- [Additional Settings](#)

Click the **HP Support** button to go to the **HP Online Support** Web site for more help on any of these topics.

Access to the HP (Printer) Utility

In Mac OS X v10.4, v10.5, and later, follow these steps to gain access to the HP (Printer) Utility:

1. In the **Finder**, click **Applications** and then click **Utilities**.

- Click to select the **HP (Printer) Utility**. The main **HP Utility** screen appears. Click the product in the **Printers** list.

Figure 5-10 HP Utility main screen



The following sections describe the screens and features that are available in the HP Utility.

Supplies Status

In the **Information And Support** section of the HP Utility, click **Supplies Status** to open the **Supplies Status** screen.

Figure 5-11 Supplies Status screen

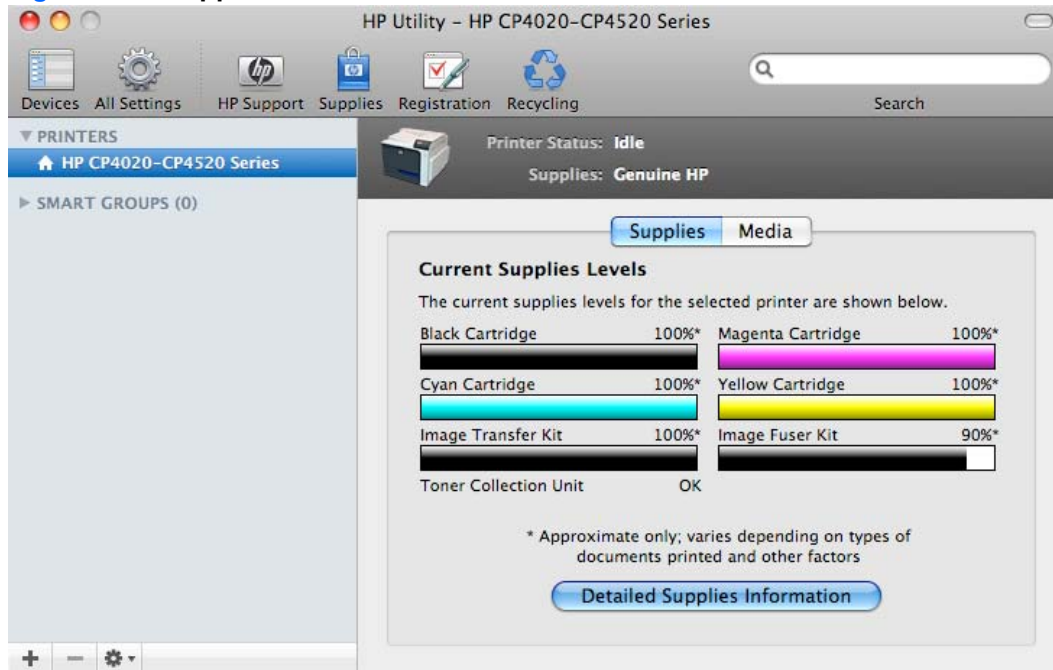

Click **Detailed Supplies Information...** to open the **Supplies Status** details screen.

Use the scroll button to see information about the color print cartridges.

On the **Supplies Status** screen, click **Media** to see the status of the trays.

You can also order supplies at anytime by clicking **Supplies** in the toolbar.

Device Information

In the **Information And Support** section of the HP Utility, click **Device Information** to find the product **Service ID** (if assigned), the firmware version (**FW Version**), and the **Serial Number**.

Figure 5-12 Device Information screen



The product configuration page shows other settings; click **View Configuration Page** .

Color Usage

In the **Information And Support** section of the HP Utility, click **Color Usage** to open a screen and print a color-usage job log.

Figure 5-13 Print Color Usage Job Log screen

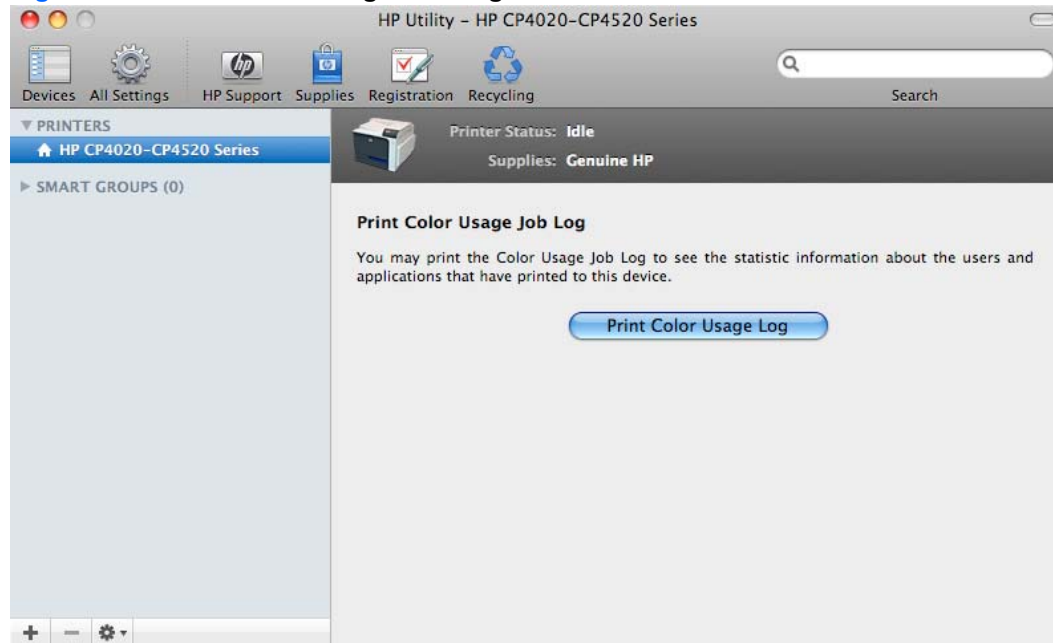

Click **Print Color Usage Log** to print a page that shows information about users, print jobs, and software programs that have printed to the HP Color LaserJet Enterprise CP4020-CP4520 Series product. In addition, the color-usage log lists the following details about print jobs:

- Date and time
- Total number of jobs
- Mono (monochrome, or black-and-white) sides
- Color sides
- paper sheets

File Upload

In the **Information And Support** section of the HP Utility, click **File Upload** to open the **File Upload** screen.

Figure 5-14 File Upload screen

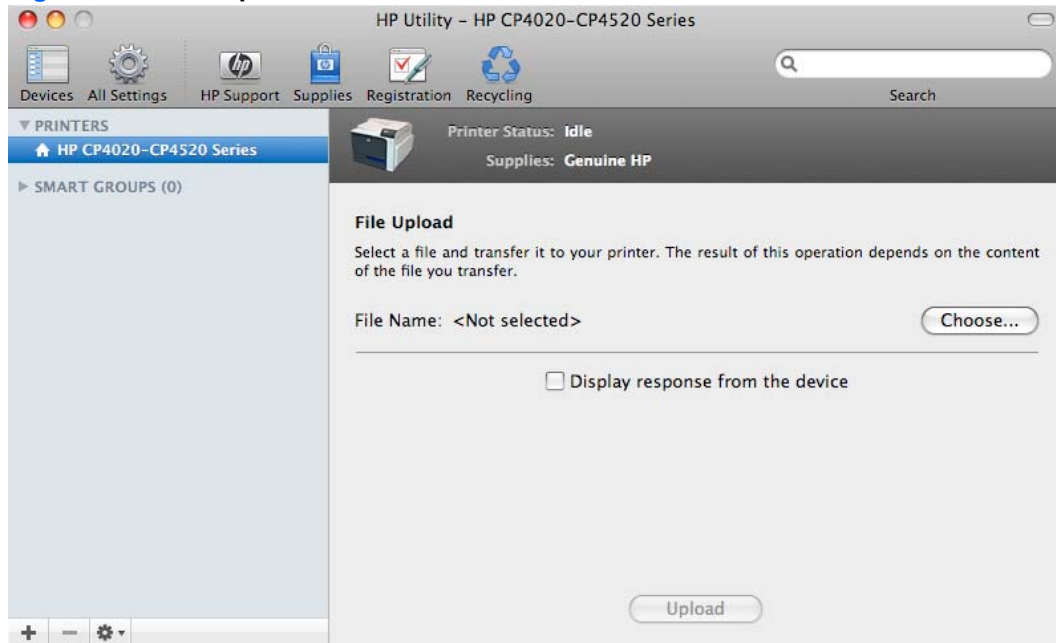

The **File Upload** command is supported for file types that can be sent directly to the product without first being opened through a software program. Some files can be uploaded to the product, but some cannot.

Documents in the following file formats can be printed by using a command line. That is, they do not need to be opened in a software program that supports the file format (such as the Adobe Acrobat or Acrobat Reader programs for .PDF files), but can be sent directly to the product by using the **File Upload** command.

- HP LaserJet printer command language (.PRN)
- Portable document format (.PDF)
- Postscript (.PS)
- Text (.TXT)

On the **File Upload** screen, click **Choose...** to open a navigation screen. Locate the file you want to upload and click **Open**.

On the **File Upload** screen, click **Display response from the device** to see whether the upload was successful. If the file loads successfully, no message appears.

On the navigation screen, select the file and click **Open**. The file name appears in the **File Upload** screen of the HP Printer Utility. Click **Upload**.

Remote firmware update by using the HP Printer Utility

Make sure that you have the tools and files that are necessary for the update. You will need the HP Printer Utility and the CP4025FW.RFU file or the CP4525FW.RFU file, which is the firmware file for

the product. The HP Printer Utility is a software program that is available only for Mac OS X v10.2 and later.

The HP Printer Utility can be found on the HP Color LaserJet Enterprise CP4020-CP4520 Series printing-system software CD-ROM that came with the product. If you do not have the CD-ROM, you can obtain the HP Printer Utility by downloading the latest product installer from www.hp.com/go/cljcp4025_software or www.hp.com/go/cljcp4525_software.

The firmware file can be downloaded from the following Web site:

www.hp.com/go/cljcp4025_firmware or www.hp.com/go/cljcp4525_firmware

After you have the firmware file and the HP Printer Utility, you are ready to begin the update process. Complete the following steps:

1. Open the HP Printer Utility.
2. In the **Information And Support** section of the HP Utility, select **File Upload**, click **Choose**, browse to firmware upgrade file, and then click **Open**.
3. On the **File Upload** screen, click **Upload**.

 **NOTE:** You might receive an error message on the screen indicating that the product is offline. Verify that the product is turned on. If it is, ignore the message. The **Updating** screen appears and the update proceeds as expected.

4. The update process can take several minutes. Let the process finish without further interaction with the product or the computer.

 **NOTE:** The product automatically turns off and then on again to activate the update; this can happen more than once. At the end of the update process, the **READY** message appears on the control panel. Do *not* turn off the product or interfere with the update until you see this message.

5. Print a configuration page and verify that the firmware revision number matches the revision of the current update.

Upload Fonts

In the **Information And Support** section of the HP Utility, click **Upload Fonts** to gain access to fonts that you can upload to the HP Color LaserJet Enterprise CP4020-CP4520 Series product.

Figure 5-15 Upload Fonts screen

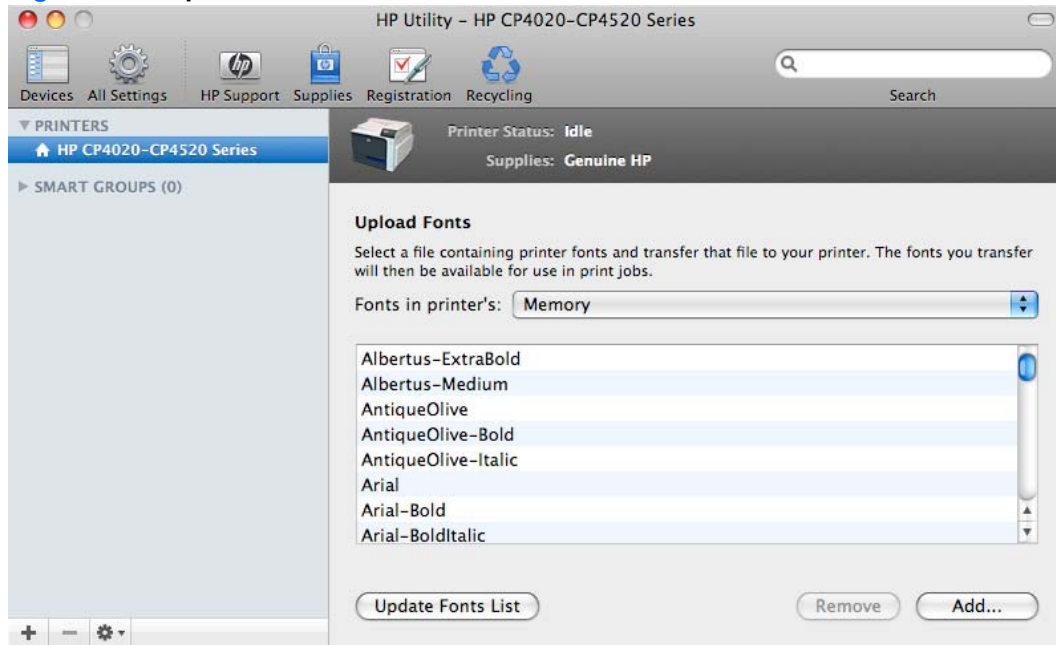

The drop-down menu in the **Upload Fonts** pane has the following options:

- **Memory.** Fonts that are available in the printer memory are listed.
- **Disk.** Select this option to show any fonts that are installed on the printer hard disk or flash disk. By default, no fonts are stored on either of these disks. To upload fonts, select the font name, and then click **Add**.

Duplex mode

For the HP Color LaserJet CP4525dn and HP Color LaserJet CP4525xh product models, the **Printer Settings** section includes a **Duplex Mode** setting. Click this setting to open the **Duplex Mode** screen.

Figure 5-16 Duplex Mode screen

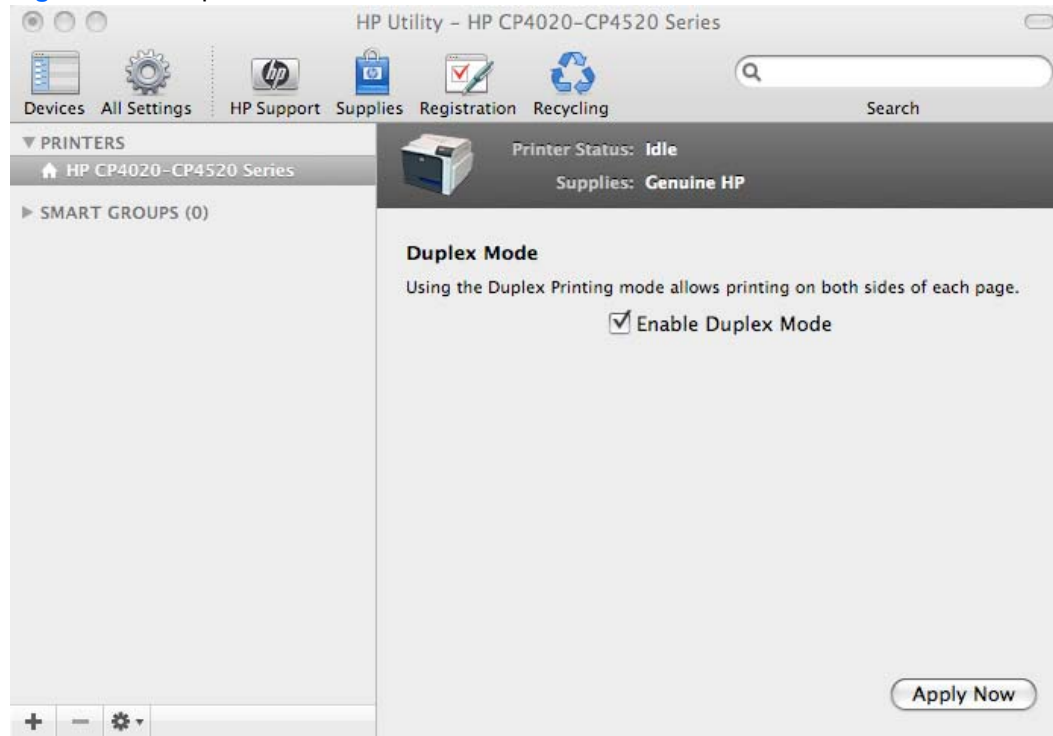

Use the Enable Duplex Mode command to print internal diagnostic and test pages on both sides of the page.

1. Select the **Enable Duplex Mode** check box. This box is clear by default.
2. Click **Apply Now** to enable printing on both sides of the page.

Trays Configuration

The **Trays Configuration** screen is shown in the following figure.

Figure 5-17 Trays Configuration screen

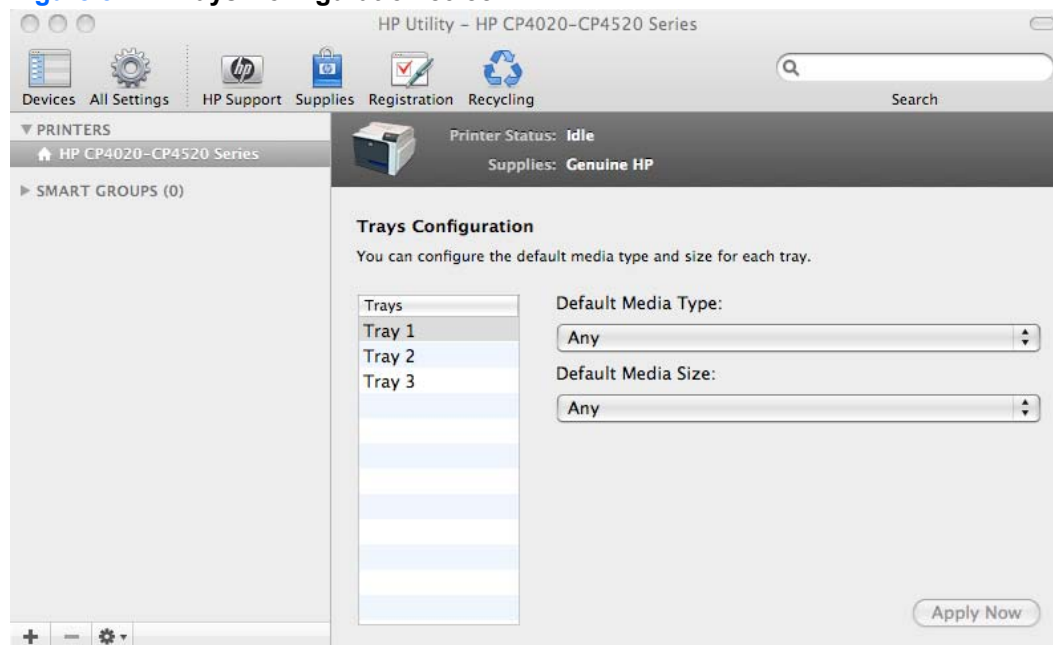

1. In the **Printer Settings** section of the HP Utility, select **Trays Configuration** to change paper size and type for each of the trays installed on your product.
2. To change the paper type, select a tray and then select a different paper type in the **Default Media Type** drop-down menu.
3. To change the paper size, select a tray and then select a different paper size in the **Default Media Size** drop-down menu.
4. Click **Apply Now** to save the settings.

Stored Jobs

In the **Printer Settings** section of the HP Utility, select **Stored Job** to change the **Enable Job Storing** setting. This setting is selected by default. Click to clear the check box to disable the job-storing feature.

Figure 5-18 Enable Job Storing screen

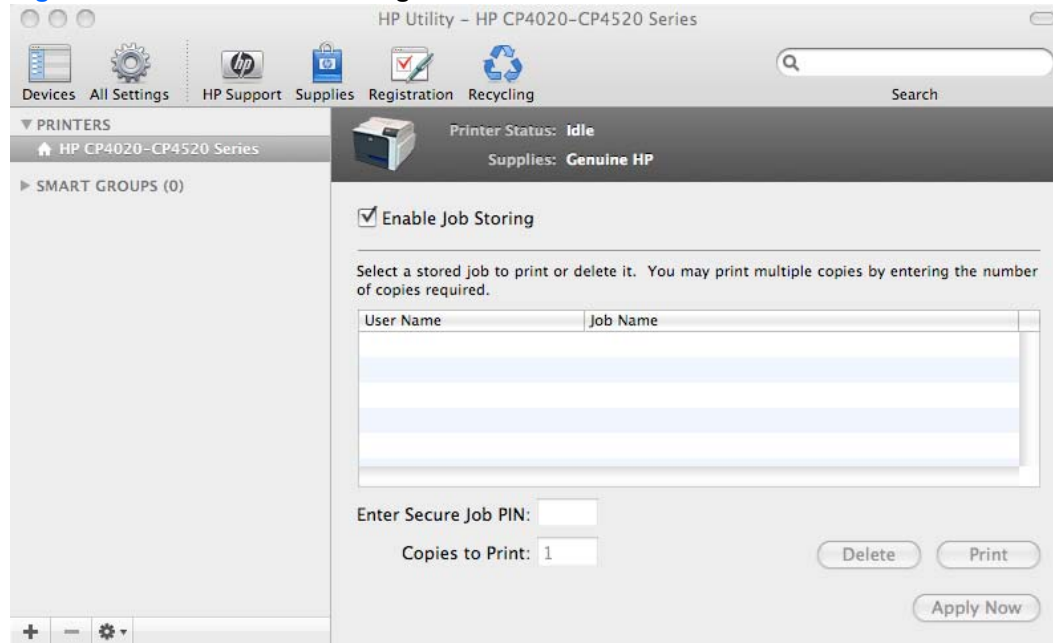

You can type a PIN for your job in the **Enter Secure Job PIN** field.

Select the number of copies in the **Copies to Print** field.

Select a stored job and click **Print** to print the job.

Select a stored job and click **Delete** to delete the job.

E-mail Alerts

In the **Printer Settings** section of the HP Utility, select **E-mail Alerts** to configure the HP Color LaserJet Enterprise CP4020-CP4520 Series product to send e-mail notifications to users.

If a user name and password have been set, you might need to obtain them from the IT administrator. For more information, see the HP EWS online help.

Figure 5-19 E-mail Alerts screen

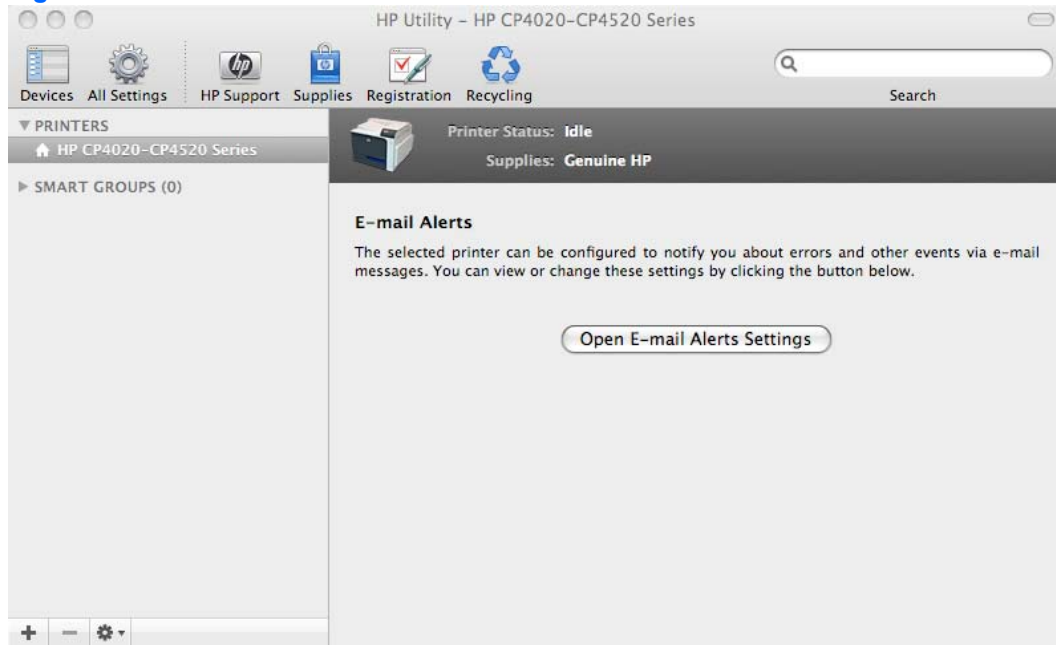

Click **Open E-mail Alerts Settings** to open the HP EWS. The HP EWS opens to the **Setup** screen on the **Alerts** tab, where you can set notifications.

Network Settings

In the **Printer Settings** section of the HP Utility, select **Network Settings** to open the **IP Settings** screen.

Figure 5-20 IPv4 Settings screen

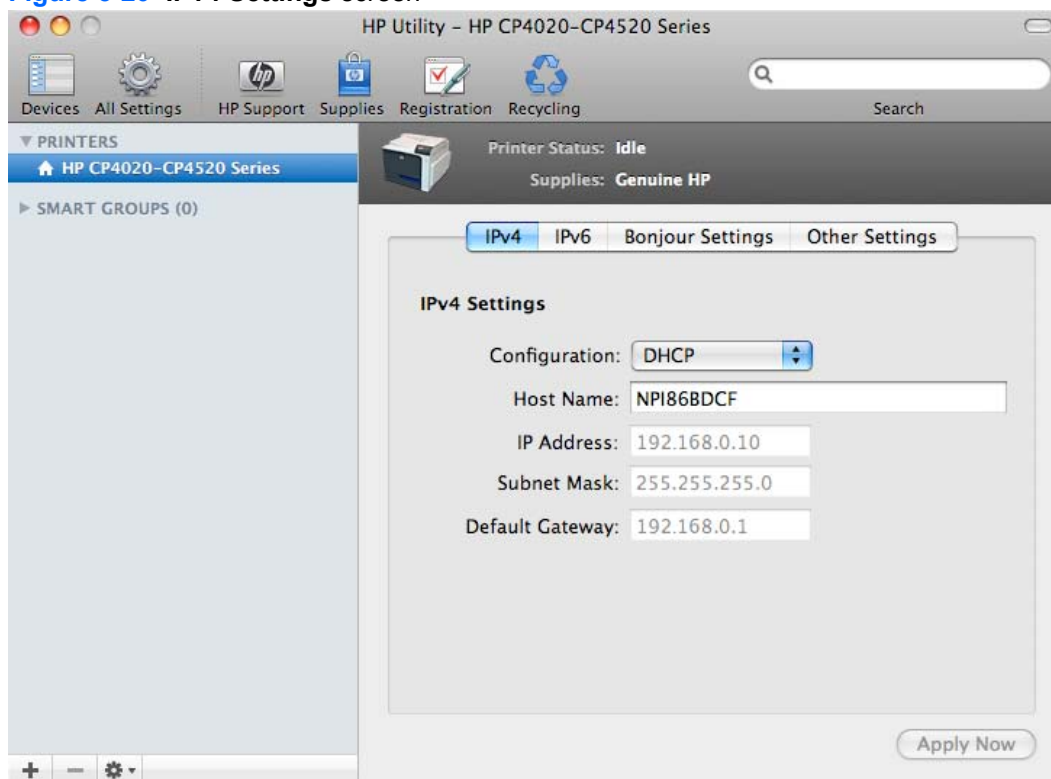

The **Network Settings** screen provides access to **IPv4**, **IPv6**, **Bonjour Settings**, and **Other Settings**.

- **DHCP**
- **BootP**
- **Manual**

You can also use this screen to modify the following settings:

- **Host Name**
- **IP Address**
- **Subnet Mask**
- **Default Gateway**

To save new settings, click **Apply Now**.

To view and change other network settings, click **Other Settings**.

If a user name and password have been set, you might need to obtain them from your IT administrator. For more information, see the HP EWS online help.

The HP EWS opens to the **Network Settings** screen.

To view and change the Bonjour network settings, click **Bonjour Settings**. Bonjour is enabled by default.

To disable Bonjour, click to clear the **Enable Bonjour** check box and then click **Apply Now**.

Figure 5-21 Bonjour Settings screen

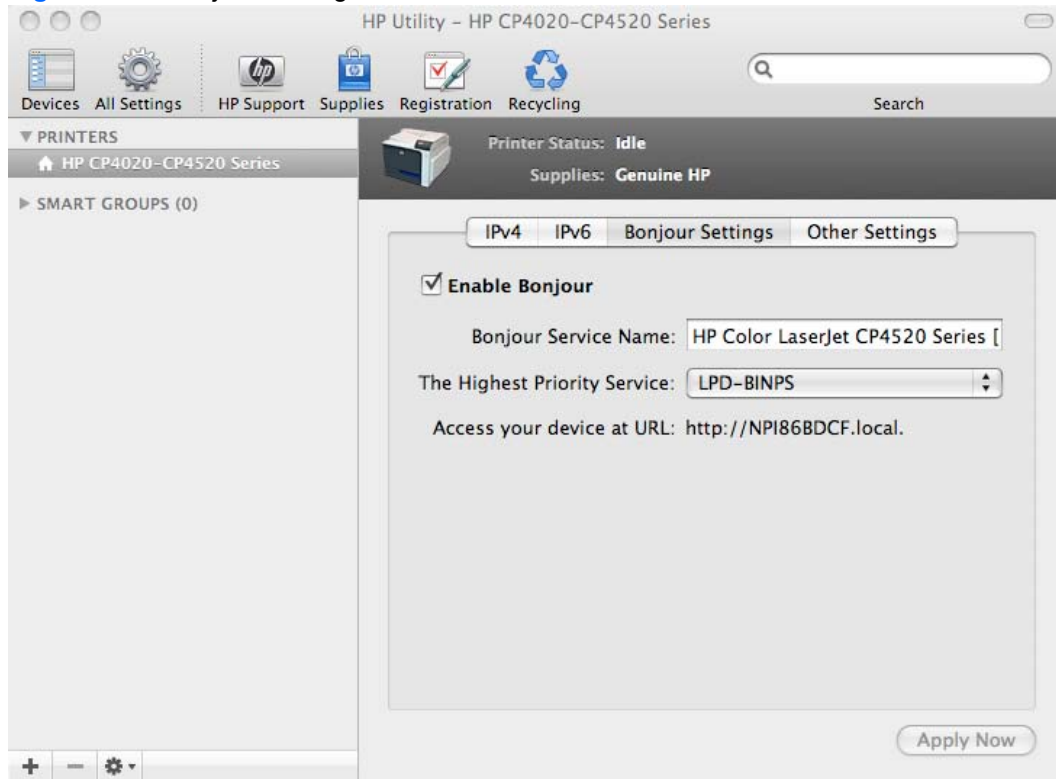

Select **Bonjour Settings** to open the **Bonjour Settings** screen. Bonjour is enabled by default.

The following options are available in the **The highest priority service** drop-down menu:

- **Port 9100** (default)
- **IPP**
- **LPD-RAW**
- **LPD-TEXT**
- **LPD-AUTO**
- **LPD-BINPS**

After you select a new setting, click **Apply Now** to save it.

Supplies Management

In the **Printer Settings** section of the HP Utility, click **Supplies Management** to open the **Supplies Management** screen.

Figure 5-22 Replace Supplies screen

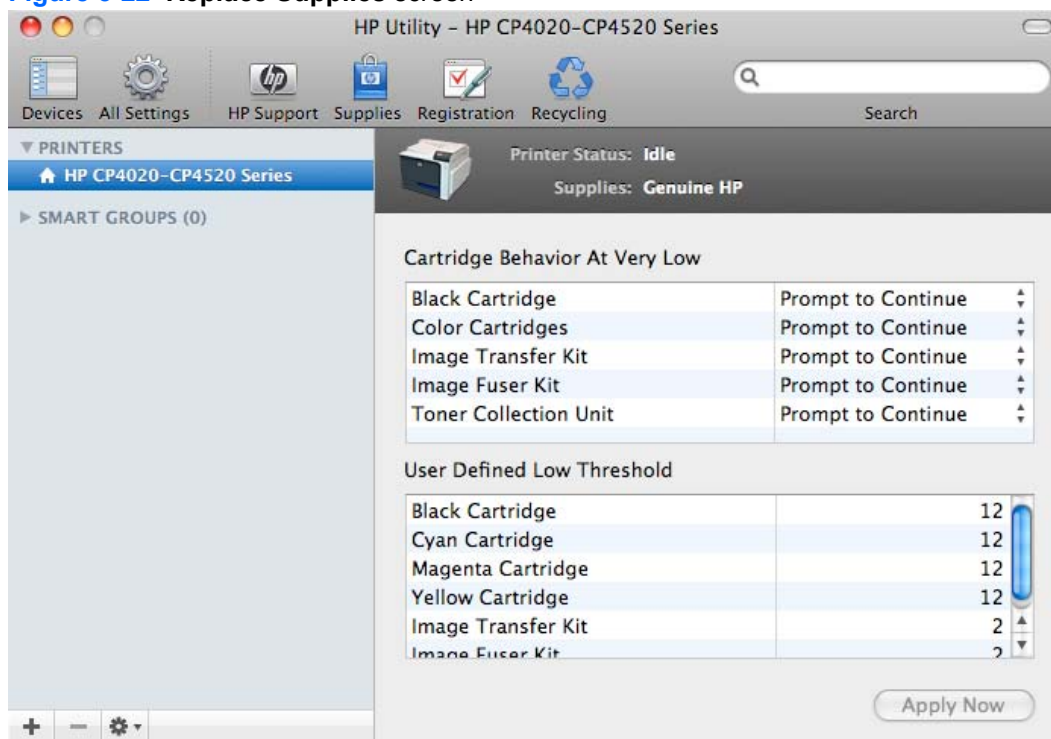

The **Supplies Management** screen allows you to define how the product responds when the supply states are **At Very Low** for cartridges, image transfer/fuser kits, and the toner collection unit. The **Supplies Management** screen also allows you to define when that very low message state or alert is given by setting the **User Defined Low Threshold** (the percentage of estimated supply life left, at which you want the product to alert you that the supply is low).

In the **Cartridge Behavior at Very Low** area, select one of the following actions for the product to take when the black cartridge, color cartridges, image transfer, image fuser, or toner collection kits, are **At Very Low**.

- **Stop**
- **Prompt to Continue** (default)
- **Continue**
- **Print in Black** (color cartridge only)

In the **User Defined Low Threshold** area, select a percentage life remaining next to the cartridge or image transfer/fuser kit to define the low threshold alert level for that cartridge or image transfer/fuser kit.

Click **Apply Now** to save the new settings.

Protect Direct Ports

In the **Printer Settings** section of the HP Utility, select **Protect Direct Ports** to disable printing over USB and parallel ports. JetDirect, embedded network connectivity, and third-party add-on cards, such as FireWire, will not be affected by this setting.

Figure 5-23 Protect Direct Ports screen

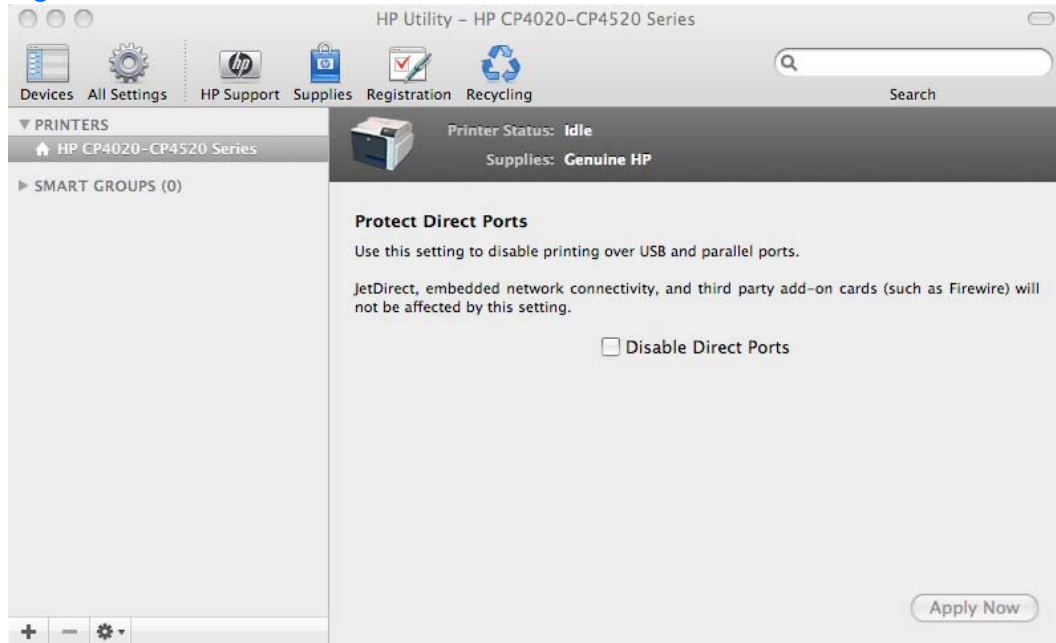

Click **Disable Direct Ports**.

Additional Settings

In the **Printer Settings** section of the HP Utility, select **Additional Settings** to gain access to the HP EWS.

Figure 5-24 Additional Settings screen

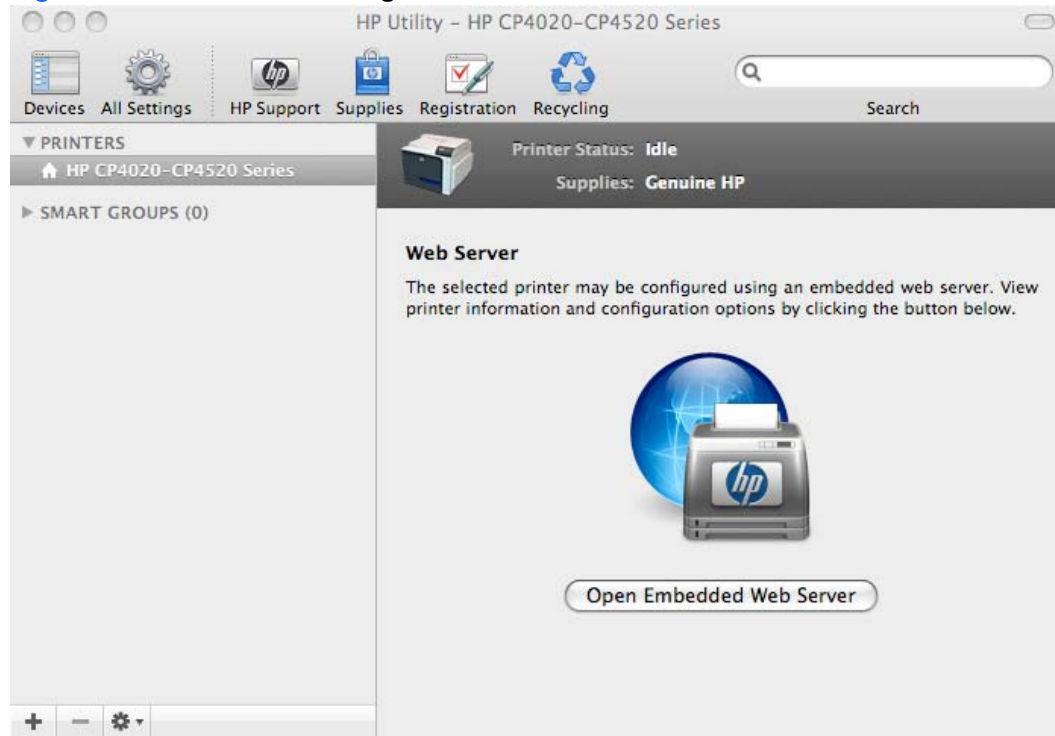

To open the HP EWS, click **Open Embedded Web Server**.

For information about HP EWS settings, consult the HP EWS online help.

6 Engineering Details

Introduction

This chapter presents engineering detail for the following topics:

- [Remote firmware update](#)
- [Printing print-ready documents](#)
- [Special paper guidelines](#)
- [Media attributes and commands](#)
- [Installation notes](#)

Remote firmware update

The HP Color LaserJet Enterprise CP4020-CP4520 Series product features remote firmware update (RFU) capability. The method for downloading remote firmware updates from the Web site is similar to that used to download the latest printing-system software and print drivers.

 **NOTE:** Firmware for the embedded Jetdirect print server will update when the printer firmware is updated.

The process for remotely upgrading firmware involves three steps:

1. Determine the current level of firmware that is installed on the product.
2. Go to the HP Web site and download the latest firmware to the computer.
3. Download the new firmware to the product.

Determining the current level of firmware

To determine the current level of firmware, view the configuration page.

On the printed Configuration Page, look in the section marked "Device (or Printer) Information" for the firmware date code and version. It will look similar to this: 20090322 48.001.0

To print a configuration page, follow these instructions.

1. Press the **menu** button  to open the menus.
2. Press the **up arrow** ▲ or the **down arrow** ▼ to scroll to **INFORMATION**, and then press **OK**.
3. Press the **up arrow** ▲ or the **down arrow** ▼ to scroll to **PRINT CONFIGURATION**.
4. Press **OK** to print the configuration page.

Downloading the new firmware from the HP Web site

The remote firmware update (.RFU) file and an associated readme file are packaged together as a self-extracting .EXE file. For detailed instructions about how to download the .EXE file, go to the following URL:

www.hp.com/go/cljcp4025_firmware or www.hp.com/go/cljcp4525_firmware

The .EXE file consists of a readme file and the .RFU file.

 **NOTE:** For UNIX systems, the remote firmware update file is a .TAR file.

For Macintosh systems, the remote firmware update file is an .SIT, .DMG, or .ZIP file.

Downloading the new firmware to the product

For support information about downloading new firmware from the Web, go to:

www.hp.com/support/cljcp4025 or www.hp.com/support/cljcp4525

The product can receive a firmware update when the product is in a **READY** state. The product waits for all of the I/O channels to become idle before performing the update.

 **NOTE:** If the firmware update involves a change in the format of nonvolatile random-access memory (NVRAM), any menu settings that are changed from the default settings will return to default settings. The settings must be changed again if you want them to be different from the defaults. Examples of settings that are affected in this way are tray types, default symbol sets, and Web-access alerts.

The elapsed time for an update depends on the I/O transfer time, as well as the time that it takes for the product to reinitialize. The I/O transfer time depends on a number of things, including the speed of the host computer that is sending the update and the I/O method (parallel or network). The reinitialization time depends on the specific hardware configuration of the product, such as the number of EIO devices installed, the presence of external paper-handling devices, and the amount of memory that is installed.

Finally, any print jobs that are ahead of the RFU job in the queue are printed before the update is processed.

Use one of the methods described in this manual to update the product firmware.

Printer messages during the firmware update

The following table lists the causes and results of possible interruptions to the firmware update.

Table 6-1 Troubleshooting a firmware update

Cause	Result
The job was cancelled from the control panel.	No update has occurred.
A break in the I/O stream occurred during send (for example, the parallel cable was removed).	No update has occurred.
A power cycle occurred during the RECEIVING UPGRADE process.	No update has occurred.
A power cycle occurred during the PERFORMING UPGRADE process.	No update has occurred. Resend the update through a parallel port or USB connection.
A power cycle occurred during the INITIALIZING process.	The update has been completed.

Print jobs that are sent to the product while an update is in process do not interrupt the update.

All HP LaserJet products leave the factory with the most recent firmware version installed. If a remote firmware update fails in a Windows OS, the .RFU file must be resent. For more information, see [Table 6-3 Update messages on page 200](#).

If a remote firmware update fails in a Macintosh OS, contact support from an HP Customer Care Center.

The following table lists possible reasons for the failure of a remote firmware update and the corrective action required for each situation.

Table 6-2 Troubleshooting a firmware update failure

Reason for firmware update failure	Corrective action
The .RFU file is corrupted.	The product recognizes that the file is corrupted and rejects the update. Download the file again and send the new file to the product. Download the file from www.hp.com/go/cljcp4025_firmware or www.hp.com/go/cljcp4525_firmware .
The wrong product is contained in the .RFU file.	The product recognizes the product mismatch and rejects the update. Download the correct file and send it to the product. Download the file from www.hp.com/go/cljcp4025_firmware or www.hp.com/go/cljcp4525_firmware .

Table 6-2 Troubleshooting a firmware update failure (continued)

Reason for firmware update failure	Corrective action
The upgrade was interrupted.	See Table 6-3 Update messages on page 200 .
A flash hardware failure occurred.	Although it is extremely unlikely, the product might have a hardware failure. Call technical support to address the problem (see the flyer that came with the product for a local telephone support list).

Three messages appear during a normal update process; a fourth (RESEND UPGRADE) appears only if the update process does not succeed.

Table 6-3 Update messages

Printer message	Explanation
RECEIVING UPGRADE	This message appears from the time the product recognizes the beginning of an .RFU update until the time the product has verified the validity and integrity of the .RFU update. NOTE: If the remote firmware update process is interrupted before the firmware is downloaded (while RECEIVING UPGRADE appears on the control-panel display), the firmware file must be sent again. No message appears on the product control panel to indicate that the update was interrupted.
PERFORMING UPGRADE	This message appears while the product is actually reprogramming the firmware. NOTE: If power is lost during the flash DIMM update (while PERFORMING UPGRADE appears on the control-panel display), the update is interrupted and the message RESEND UPGRADE appears on the control-panel display.
INITIALIZING	This message appears from the time the product has finished reprogramming the DIMM until the product reinitializes.
RESEND UPGRADE	This message appears (in English only) if the firmware update fails because the RFU process is interrupted. It can also occur if firmware for accessories (such as the duplex unit or an output device) fails to update. Perform another update by any means that is supported by the product, regardless of the connection (network, parallel, or USB).
RFU LOAD ERROR SEND RFU UPGRADE ON <X> PORT where X = Network or USB	This message appears (in English only) if the firmware update fails because the print-engine firmware is corrupted. NOTE: When this message appears, the firmware upgrade must be sent twice to upgrade all firmware components, even though the product returns to ready after the first upgrade.
DOWNLOAD FILE NOW SEND RFU UPGRADE MISMATCH BETWEEN PRODUCT AND FILE	The wrong firmware file was sent to the product. Send the correct firmware file.

 **NOTE:** To verify that the firmware update succeeded, print a new configuration page from the control panel and verify that the firmware date code on the configuration page has changed.

NOTE: If the product exhibits unexpected behavior after correcting a firmware update, turn the power off, and then back on.

Downloading custom color profiles

Obtain custom color profiles just as you would any other remote-firmware update, using the procedures described in these sections.

Custom color-profile .RFU files are named as follows:

clj#####_<what>_<version>.RFU

where:

- ##### is the product-model number of the color table
- <what> is a one-word description of what the table does
- <version> is a two-part version number consisting of a major and a minor value

For example, some custom color-profile .RFU files that could be available include:

- A simulation of the color settings for the HP Color LaserJet 4650 product:
clj4650_.RFU
- A remote-firmware-update file that resets your product to its original state:
reset_.RFU

While every care is taken to ensure a close match with the colors available on the product, several factors can affect the outcome of the match:

- Differences between products within and between a given model line
- paper type
- The age and state of the custom-profile product and the product to which the profile is to be downloaded
- The use or non-use of genuine HP supplies
- Environmental conditions



Remote firmware update by using FTP through a browser

Complete the following steps to update the product firmware by using file transfer protocol (FTP) through a browser.

 **NOTE:** This method is not recommended with Windows Vista or if Internet Explorer 7 is installed on your computer, due to frequent timeouts. A stand-alone FTP client program is recommended for Windows Vista.

NOTE: The following instructions can be used in Windows operating systems only.

1. Make note of the TCP/IP address on the EIO-Jetdirect page. The EIO-Jetdirect page is the second page of the configuration page printout. To print a configuration page, see [Determining the current level of firmware on page 198](#)
2. Open a browser window.

3. In the address line of the browser, type `ftp://<IPADDRESS>`, where `<IPADDRESS>` is the TCP/IP address of your product. For example, if the TCP/IP address is 192.168.0.90, type `FTP://192.168.0.90`
 4. Locate the downloaded .RFU file for the product.
 5. Drag and drop the .RFU file onto the **PORT4** icon or onto any open space in the browser window.
-
-  **NOTE:** If the **PORT4** icon does not appear as a folder name, you might have to enable folder viewing for FTP sites in your Web browser. In Microsoft Internet Explorer, use the following procedure to enable the folder view.
- a. Select **Tools**, select **Internet Options**, and then select the **Advanced** tab.
 - b. Select the **Enable folder view for FTP sites**.
 - c. Click **OK** to save the setting.
6. The download process begins and the firmware is updated on the product. This can take several minutes. Let the process finish without further interaction with the product or the computer. The messages described in the section [Printer messages during the firmware update on page 199](#) appear on the control panel.
-
-  **NOTE:** The product automatically turns off and then on again to activate the update; this can happen more than once. At the end of the update process, the **READY** message appears on the control panel. Do *not* turn off the product or interfere with the update until you see this message.
7. Print a configuration page and verify that the firmware revision number matches the revision of the current update.

Remote firmware update by using FTP on a direct network connection (Windows)

If the HP Color LaserJet CP4525 uses a direct network connection, use file transfer protocol (FTP) to update the firmware. Complete the following steps.

1. Make note of the TCP/IP address on the Embedded Jetdirect page. The HP Embedded Jetdirect page is the second page of the configuration page printout. To print a configuration page, see [Determining the current level of firmware on page 198](#)
-
-  **NOTE:** Before connecting to the product, make sure that the product is not in Powersave mode. Also make sure that any error messages are cleared from the control-panel display.
2. Open a command window on the computer.
 3. Type `ftp <TCP/IP product ADDRESS>`. For example, if the TCP/IP address is 192.168.0.90, type `ftp 192.168.0.90`.
 4. Press **Enter** on the keyboard.
 5. When prompted for the user name, press **Enter**.
 6. When prompted for the password, press **Enter**.
 7. Type `bin` at the command prompt.
 8. Press **Enter**. The message **200 Type set to I, Using binary mode to transfer files** appears in the command window.

9. Type `put <FILENAME>`, where `<FILENAME>` is the name of the .RFU file that was downloaded from the Web, including the path. For example, type `put C:\LJ\CP4520FW.RFU`, and then press **Enter**.

 **NOTE:** If the file name or path includes a space, you must enclose the file name or path in quotation marks. For example, type the following path:

```
put "c:\My Documents\LJ\CP4520fw.rfu"
```

The following series of messages appears in the command window:

200 PORT command successful

150 Opening BINARY mode data connection

226 Ready

226 Processing Job

226 Transfer complete

After these messages appear, a message containing transfer-speed information appears.

10. The download process begins and the firmware is updated on the product. This can take several minutes. Let the process finish without further interaction with the product or the computer. The messages described in the section [Printer messages during the firmware update on page 199](#) appear on the control panel.

 **NOTE:** The product automatically turns off and then on again to activate the update; this can happen more than once. At the end of the update process, the **READY** message appears on the control panel. Do *not* turn off the product or interfere with the update until you see this message.

11. Print a configuration page and verify that the firmware revision number matches the revision of the current update.
12. At the command prompt, type `bye` to exit the FTP command.
13. At the command prompt, type `exit` to return to the Windows interface.

Remote firmware update through a local Windows port

If the product is connected through a local port (parallel), then you can send the .RFU file directly to the product by using a `COPY` command from a command prompt or an MS-DOS window. At the command prompt, perform the following steps for your operating system.

Windows 2000, Windows XP, Windows Server 2003, or Windows Server 2008

The .RFU file can be sent directly to the product by typing a **copy** command at a command prompt or in an MS-DOS window.

1. At a command prompt, type `copy /b <FILENAME> <PORTNAME>`, where <FILENAME> is the name of the .RFU file (including the path) and <PORTNAME> is the name of the appropriate printer port (such as LPT1). For example, type the following:

```
C:\>copy /b c:\CP4520fw.rfu lpt1
```

 **NOTE:** If the file name or path includes a space, you must enclose the file name or path in quotation marks. For example, type `C:\>copy /b "c:\My Documents\CP4520fw.rfu" lpt1`

2. Press **Enter** on the keyboard.
3. The download process begins and the firmware is updated on the product. This can take several minutes. Let the process finish without further interaction with the product or the computer. The messages described in the section [Printer messages during the firmware update on page 199](#) appear on the control panel.

 **NOTE:** The product automatically turns off and then on again to activate the update; this can happen more than once. At the end of the update process, the **READY** message appears on the control panel. Do *not* turn off the product or interfere with the update until you see this message.

4. Print a configuration page and verify that the firmware revision number matches the revision of the current update.
5. At the command prompt, type `exit` to close the command window.

Remote firmware update through a USB port

Before you can send a firmware upgrade through the USB port, you need to know the name of the computer the printer is connected to, and you need to enable printer sharing. The following steps for finding your computer name and sharing a printer are specifically for Windows® XP. Finding your computer name and sharing a printer using other versions of Windows operating systems are similar, with slightly different operations.

Find the name of your computer.

1. Click the **Start, Programs, Accessories, System Tools**, and then choose **System Information**.
2. Locate your computer's name in the right window-pane next to **System Name**.
3. Write down your computer name to use later.

Share the connected printer.

1. Click the **Start, Settings**, then select **Printers and Faxes**.
2. Right-click the printer to receive the upgrade, and select **Sharing...**
3. Choose the radio button labeled **Share this printer**.

4. Enter a name for the share. Make it short and easy to remember. For example: "HP LaserJet mfp". Write down this sharename to use later.
5. Click **Apply**.

Follow these instructions to perform a remote firmware update for products connected over a USB connection:

1. From a command prompt or in an MS-DOS window, type `copy /b <FILENAME>\<COMPUTERNAME>\<SHARENAME>`, where <FILENAME> is the name of the .RFU file (including the path), <COMPUTERNAME> is the name of the computer from which the product is being shared, and <SHARENAME> is the product share name. For example, type the following:

```
copy /b CP4520fw.rfu\\your_computer\clj4520
```

 **NOTE:** If the file name or path includes a space, you must enclose the file name or path in quotation marks. For example, type `C:\>copy /b "c:\My Documents\CP4520fw.rfu" \\your_computer\clj4520`

2. Press **Enter** on the keyboard. The messages described in the section [Printer messages during the firmware update on page 199](#) appear on the control panel. The message **1 file(s) copied** appears on the computer screen.
3. The download process begins and the firmware is updated on the product. This can take several minutes. Let the process finish without further interaction with the product or the computer. The messages described in the section [Printer messages during the firmware update on page 199](#) appear on the control panel.

 **NOTE:** The product automatically turns off and then on again to activate the update; this can happen more than once. At the end of the update process, the **READY** message appears on the control panel. Do *not* turn off the product or interfere with the update until you see this message.

4. Print a configuration page and verify that the firmware revision number matches the revision of the current update.

Remote firmware update through a Windows network

If the product is shared on a Windows network, follow these instructions:

1. From a command prompt or in an MS-DOS window, type `copy /b <FILENAME> \<COMPUTERNAME>\<SHARENAME>`, where <FILENAME> is the name of the .RFU file (including the path), <COMPUTERNAME> is the name of the computer from which the product is being shared, and <SHARENAME> is the product share name. For example, type the following:

```
C:\>copy /b c:\CP4520fw.rfu \\your_server\your_computer
```

 **NOTE:** If the file name or path includes a space, you must enclose the file name or path in quotation marks. For example, type `C:\>copy /b "c:\My Documents\CP4520fw.rfu" \\your_server\your_computer`

2. Press **Enter** on the keyboard. The messages described in the section [Printer messages during the firmware update on page 199](#) appear on the control panel. The message **1 file(s) copied** appears on the computer screen.
3. The download process begins and the firmware is updated on the product. This can take several minutes. Let the process finish without further interaction with the product or the computer. The

messages described in the section [Printer messages during the firmware update on page 199](#) appear on the control panel.

 **NOTE:** The product automatically turns off and then on again to activate the update; this can happen more than once. At the end of the update process, the **READY** message appears on the control panel. Do *not* turn off the product or interfere with the update until you see this message.

4. Print a configuration page and verify that the firmware revision number matches the revision of the current update.

Remote firmware update by using the LPR command

 **NOTE:** This remote firmware update method is for use in Windows 2000, Windows XP, Windows Server 2003, and Windows Server 2008.

Complete the following steps to update the firmware by using the LPR command.

1. From a command window, type the following:

```
lpr -P <IPADDRESS> -S <IPADDRESS> -o l <FILENAME>
```

OR

```
lpr -S <IPADDRESS> -Pbins <FILENAME>
```

where IPADDRESS can be either the TCP/IP address or the hostname of the product, and where FILENAME is the filename of the .RFU file.

 **NOTE:** The parameter (-o l) consists of a lowercase "O", not a zero, and a lowercase "L", not the numeral 1. This parameter sets the transport protocol to binary mode.

2. Press **Enter** on the keyboard. The messages described in the section [Printer messages during the firmware update on page 199](#) appear on the control panel.
3. The download process begins and the firmware is updated on the product. This can take several minutes. Let the process finish without further interaction with the product or the computer. The messages described in the section [Printer messages during the firmware update on page 199](#) appear on the control panel.

 **NOTE:** The product automatically turns off and then on again to activate the update; this can happen more than once. At the end of the update process, the **READY** message appears on the control panel. Do *not* turn off the product or interfere with the update until you see this message.

4. Print a configuration page and verify that the firmware revision number matches the revision of the current update.
5. Type `exit` at the command prompt to close the command window.

HP Easy Firmware Upgrade utility

Use the HP Easy Firmware Upgrade utility to send a firmware file to the HP Color LaserJet Enterprise CP4020-CP4520 Series.

When a firmware file is downloaded from the HP Web site, the .ZIP file contains two files, the HP Easy Firmware Upgrade utility self-extracting firmware executable and the readme file that is applicable for the product and firmware revision you are downloading.

The HP Easy Firmware Upgrade utility uses the current print path, USB, or network connection to communicate with the device, and does not require the use of the Windows spooler. This utility is only available for Windows operating systems.

Follow these instructions to complete the firmware update.

 **NOTE:** In some circumstances, the update might require ten minutes or more to complete.

Do not power cycle the product or the computer during this process or the product may become unstable and or unusable.

1. Download the HP Easy Firmware Upgrade utility from the following Web site.
www.hp.com/go/cljcp4025_firmware or www.hp.com/go/cljcp4525_firmware
2. Double-click and extract the downloaded file to your desktop.
3. Print a configuration page from the device. Under the Device Information heading, note the datecode and version number. These should change after you have successfully completed the firmware update. To print a configuration page, see [Determining the current level of firmware on page 198](#).
4. Verify that the printer is at a **Ready** state.
5. On your computer, locate the HP Easy Firmware Upgrade utility file.
6. Double-click the HP Easy Firmware Upgrade utility file. The following dialog box appears.

Figure 6-1 HP Easy Firmware Upgrade utility screen 1

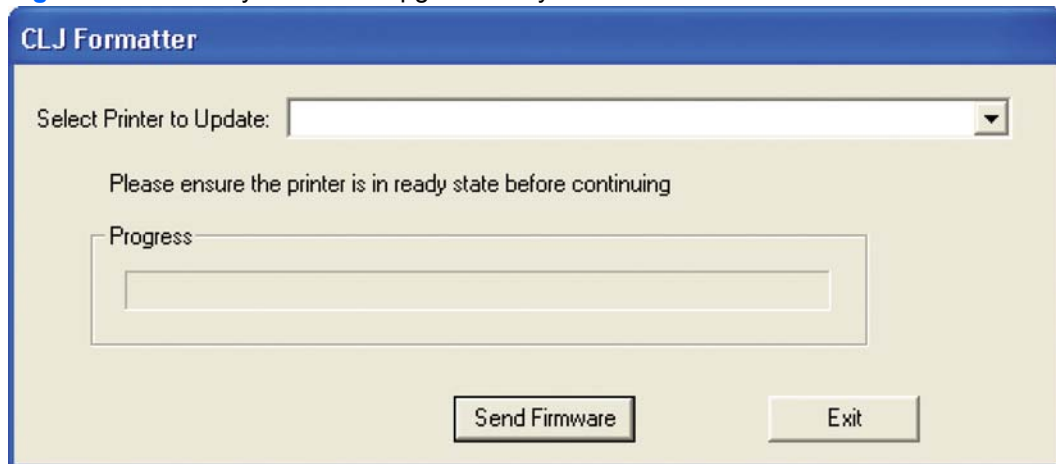

7. Click the down arrow next to the **Select Printer to Update:** drop-down list and select the device you want to update.



 **NOTE:** If the device you want to upgrade is not in the list, you must install a printer-driver for the device and be able print to the device with the printer-driver before continuing.

Figure 6-2 HP Easy Firmware Upgrade utility screen 2

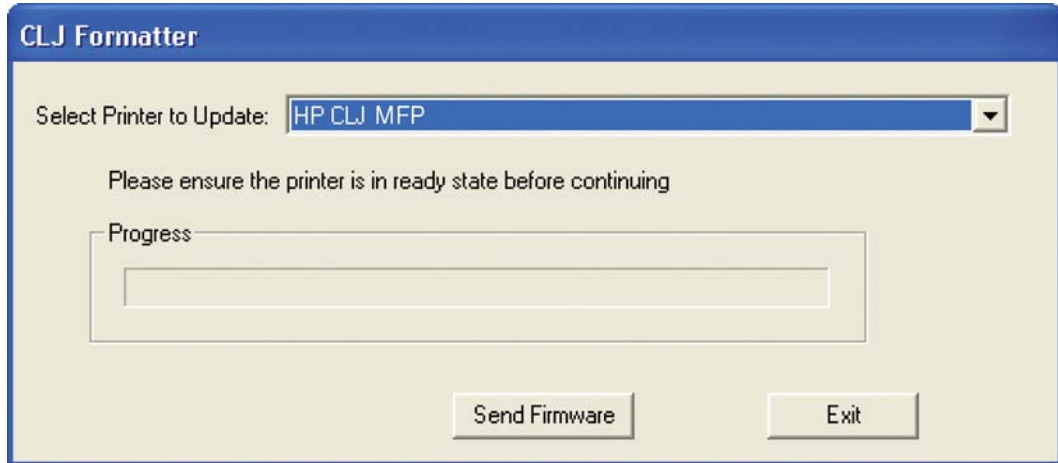

8. Click the **Send Firmware** button to begin the update process.

 **CAUTION:** Interrupting the firmware upgrade process by turning the printer off and then turning it on again or by attempting to send a print job to the printer might cause the printer to go into an unrecoverable state.

9. The progress bar gradually moves to the right during the firmware upgrade process.

 **NOTE:** The progress bar does not necessarily reflect the actual time needed for the firmware upgrade to complete.

Figure 6-3 HP Easy Firmware Upgrade utility progress screen



10. The upgrade process is complete when an icon appears in the lower-right corner of the dialog box. A smiling icon appears when the utility completes successfully. A frowning icon appears when the utility completes unsuccessfully.

If the frowning icon appears, check to make sure the printer is on and at a **Ready** state. Verify that you can send print jobs to the printer, and then try again to perform the firmware update.

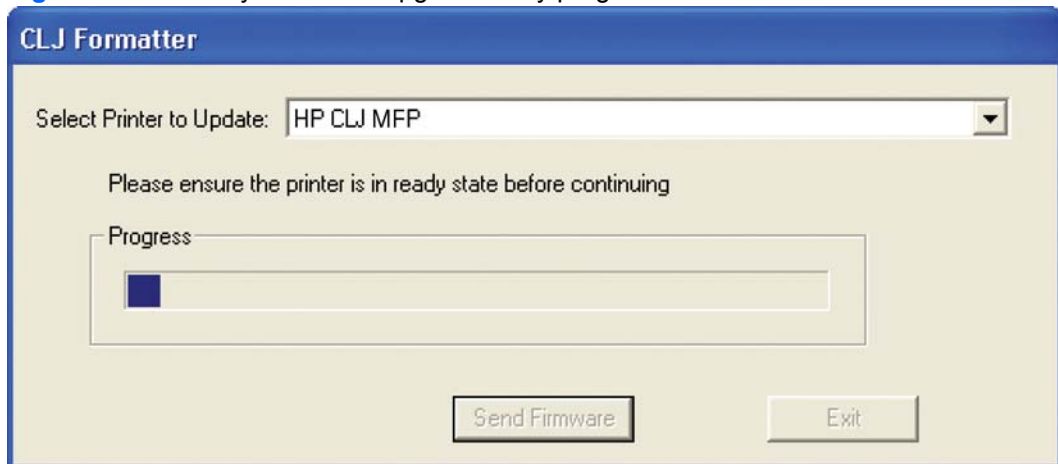
Figure 6-4 HP Easy Firmware Upgrade utility complete screen

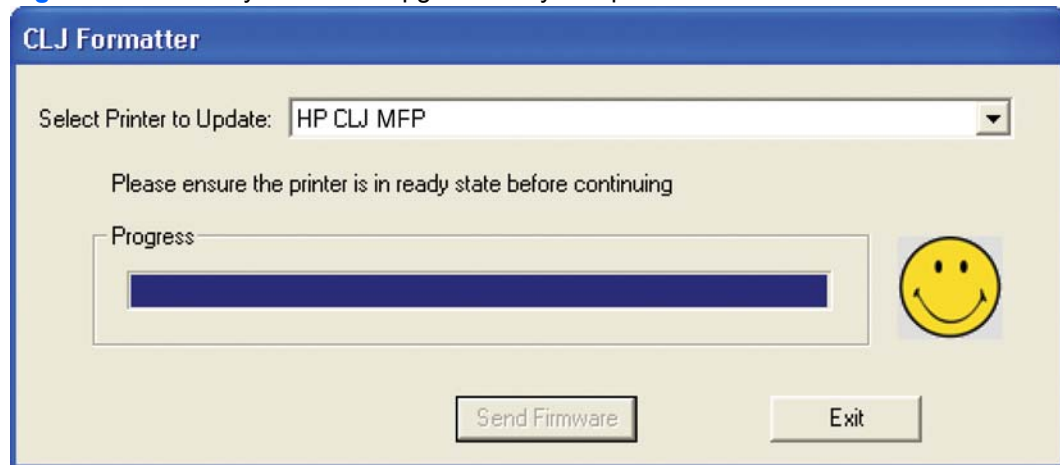

11. Click **Exit** to close the dialog box.
12. The product automatically turns itself off and then on again.
13. When the device is at a **Ready** state, print a Configuration page to verify that the version has changed.

Remote firmware update through HP Web Jetadmin

Remote firmware update using HP Web Jetadmin V7.8 or 8.x

This procedure requires that you install HP Web Jetadmin V7.8 or 8.x on the computer. Complete the following steps to update a single product through HP Web Jetadmin after downloading the .RFU file from the HP Web site.

1. Start HP Web Jetadmin.
2. Type the TCP/IP address or IP host name of the product in the **Quick Device Find** field, and then click **Go**. The product Status window opens.
3. Open the **Device Management** folder in the drop-down list in the Navigation panel. Navigate to the **Device Lists** folder.
4. Expand the **Device Lists** folder and select **All Devices**. Locate the product that you want to update in the list of products, and click to select it.
5. Locate the drop-down box for **Device Tools** in the upper-right corner of the window. Select **Update Printer Firmware** from the **choose action** list.
6. If the name of the .RFU file is not listed in the **All Available Images** dialog box, click **Browse** in the **Upload New Firmware Image** dialog box and navigate to the location of the .RFU file that you downloaded from the Web at the start of this procedure. If the filename is listed, select it.

7. Click **Upload** to move the .RFU file from your hard drive to the HP Web Jetadmin server.
8. Refresh the browser.
9. Select the .RFU file from the **Printer Firmware Update** drop-down menu.
10. Click **Update Firmware**. HP Web Jetadmin sends the selected .RFU file to the product.
11. The download process begins and the firmware is updated on the product. This can take several minutes. Let the process finish without further interaction with the product or the computer. The messages described in the section [Printer messages during the firmware update on page 199](#) appear on the control panel.

 **NOTE:** The product automatically turns off and then on again to activate the update; this can happen more than once. At the end of the update process, the **READY** message appears on the control panel. Do *not* turn off the product or interfere with the update until you see this message.

HP Web Jetadmin V7.8 or 8.x can also be used to perform multiple or unattended installations. Complete the following steps for multiple or unattended installations.

1. Start HP Web Jetadmin.
2. Create a device group. A simple way to do this is to follow these steps:
 - a. Click **Device Management**, and then click **All Devices**.
 - or-
 - b. Shift-click to select products that you want to be included in the group, and then click **OK**.
 - or-
 - c. When prompted, type a name for the new device group, and then click **OK**.
3. To modify several products in a group, click the group name, and then click **Open**.
4. The drop-down menu for **Device Group Tools** appears on the right side of the window. Scroll if necessary to view it.
5. In the **Device Group Tools** drop-down box, select an action. Type the appropriate information. Click **Return to Device Group** when finished.

Remote firmware update using HP Web Jetadmin 10.x

 **NOTE:** HP Web Jetadmin can be configured to get firmware details from hp.com directly. Use Tools, Options, Shared, Network, HTTP to add HTTP proxy details (if needed) and to enable “Allow download”. “Allow download” is required for HP Web Jetadmin to communicate with the Internet. Once these settings are enabled, HP Web Jetadmin may be able to get firmware listing and firmware image files directly from HP.com if this is allowed on the network where HP Web Jetadmin is running.

1. Start Web Jetadmin 10.x
2. From the **Device Management** section, select **All Devices** (or the appropriate device group). An **All Devices** list will appear in the center window.
3. Find your device in the list, or type the IP address of the device in the **Quick Device Discovery** section in the lower-left of the screen (this will highlight your device in the device list). You can sort the device list by clicking on a column name at the top.

4. If your device list is sorted by model number, you may select multiple devices with the same model number by Control-Click or Shift-Click.
5. Right-click on the device and select **Upgrade firmware...**
6. An **Upgrade Firmware** window will appear. Select **Device firmware** and then click **Next**.
7. A list of available firmware will appear. If the correct version is listed, click **Next**, and the upgrade process will start.

If the correct firmware version does not appear on the list, perform a manual upload. New firmware may be available on an FTP site prior to appearing on hp.com. The instructions below allow you to upload a RFU file from your local PC to WJA 10.

Perform a manual firmware upload.

1. Click on **Firmware/Firmware Repository** in the **Device Management** pane.
2. A Firmware Repository window displays in the center of the screen
3. Click on **Upload** in the upper-right of the window.
4. Browse to the .rfu file on your computer.
5. Click **Upload**.
6. Once the .rfu file is uploaded, perform steps 2 through 6 in the remote firmware update procedure.

 **NOTE:** Do not turn printer off during the update process! When the update process is complete, the printer will automatically reboot. If the firmware update process fails, Web JetAdmin will provide notification with a page (screen) of information regarding the reason(s) for failure. A link will be provided to attempt the process again.

Remote firmware update by using FTP on a direct network connection (Macintosh)

 **NOTE:** The Mac version of the firmware file on the Web is .DMG. It is a compressed file format for Macintosh. Once uncompressed, both a Readme and the .RFU file are visible.

Make a note of the TCP/IP address on the EIO-Jetdirect page. The EIO-Jetdirect page is the second page of the configuration page printout. To print a configuration page, see [Determining the current level of firmware on page 198](#).

Remote firmware update using the HP Printer Utility (Macintosh OS X)

The HP Printer Utility is a software program which is available in Mac OS X V10.3 and later. The HP Printer Utility gives you access to product features and settings in and can be found on the software CD which came with the product.

If you do not have the CD, you can obtain the HP Printer Utility by downloading the latest product installer from the following Web sites: www.hp.com/go/cljcp4025_software or www.hp.com/go/cljcp4525_software

The HP Printer Utility must be installed using IP, Bonjour, Rendezvous, or a USB connection. The HP Printer Utility does not work when it is installed by using the AppleTalk protocol.

Follow these steps to perform a remote firmware update using the HP Printer Utility.

1. Open the HP Printer Utility. The utility can be found in the Application/Utilities folder by choosing the HP Printer Selector
2. Choose your product from the list and click **Select**. Proceed to step 5.
 - If a list of printers does not appear in the HP Printer Utility, click on the printer icon in the lower left corner.
 - Choose your product from the list, Press **Select** and proceed to step 5.
3. If the product does not appear, click **More Printers....** The **Connection Type** screen displays.
4. Choose the connection type (USB or TCP/IP). Select the product name or enter in an IP address.
5. On the **Connection Type** screen, click **Add**. The **Select Printer** screen displays.
6. Choose your product from the list and click **Select**.
7. Select **Update Firmware** on the left side of the window, click **Choose**, browse to firmware upgrade file, and then click **Open**.
8. On the Update Firmware screen, click **Update**.

Remote firmware update for UNIX systems

 **NOTE:** The UNIX version of the firmware file on the Web is in .TAR format. TAR is a compressed file format for UNIX. Once uncompressed, both a Readme and the .RFU file are visible.

For UNIX systems, any command method that delivers the .RFU file to the product is acceptable, including the following:

1. At the command prompt, type `cp /home/yourmachine/FILENAME /dev/parallel>`, where `</home/yourmachine/FILENAME>` is the location of the .RFU file.
2. The download process begins and the firmware is updated on the product. This can take several minutes. Let the process finish without further interaction with the product or the computer. The messages described in the section [Printer messages during the firmware update on page 199](#) appear on the control panel.

 **NOTE:** The product automatically turns off and then on again to activate the update; this can happen more than once. At the end of the update process, the **READY** message appears on the control panel. Do *not* turn off the product or interfere with the update until you see this message.

3. Print a configuration page and verify that the firmware revision number matches the revision of the current update.

Printing print-ready documents

Several methods are available for printing documents independently of the original software program that was used to create the document. Normally, the document is printed by opening the original application and printing it to a file, or is printed by means of a distribution method such as internet downloading. The following print-ready file formats can be sent directly to the HP Color LaserJet Enterprise CP4020-CP4520 Series product without first opening the original software program:

- HP LaserJet Printer Control Language (.PRN)
- Portable Document Format (.PDF)
- Postscript (.PS)
- Text (.TXT)

Use one of the following methods to send print-ready files to your product.

 **NOTE:** The examples that are used here are for printing .PDF documents. However, any print-ready file type can be substituted.

Print-ready file printing by using FTP through a browser

Complete the following steps to print print-ready files directly by using FTP through a browser.

 **NOTE:** The following instructions can be used on Windows or Macintosh operating systems.

1. Make note of the TCP/IP address on the Embedded Jetdirect page. The HP Embedded Jetdirect page is the second page of the configuration page printout. To print a configuration page, see [Determining the current level of firmware on page 198](#).
2. Open a browser window.
3. In the address line of the browser, type `ftp://<IPADDRESS>`. For example, if the TCP/IP address of your product is 192.168.0.90, type the following:

```
FTP:// 192.168.0.90
```

4. Locate the print-ready file for the product.
5. Drag and drop the print-ready file onto the **PORT** icon in the browser window.

 **NOTE:** If the **PORT** icon does not appear as a folder name, you might have to enable folder viewing for FTP sites in your Web browser. In Microsoft Internet Explorer, use the following procedure to enable the folder view.

1. Select **Tools**, then select **Internet Options**, and then select the **Advanced** tab.
2. Select the **Enable folder view for FTP sites**.
3. Click **OK** to save the setting.

Print-ready file printing by using FTP on a direct network connection (Windows)

If the HP Color LaserJet Enterprise CP4020-CP4520 Series uses a direct network connection, use file transfer protocol (FTP) to print a print-ready file. Complete the following steps for the operating system:

1. Take note of the TCP/IP address on the Embedded Jetdirect page. The HP Embedded Jetdirect page is the second page of the Configuration page printout. To print a configuration page, see [Determining the current level of firmware on page 198](#).

2. Open a command window on the computer.

3. Type `ftp <TCP/IP product ADDRESS>`. For example, if the TCP/IP address is 192.168.0.90, type the following:

```
ftp 192.168.0.90
```

4. Press **Enter** on the keyboard.

5. When prompted for the user name, press **Enter**.

6. When prompted for the password, press **Enter**.

7. Type `bin` at the command prompt.

8. Press **Enter**. The message **200 Types set to I, Using binary mode to transfer files** appears in the command window.

9. Type `put <FILENAME>`, where `<FILENAME>` is the name of the print-ready file to be printed, including the path. For example, type the following:

```
put C:\LJ\CP4520FW.PDF
```

 **NOTE:** If the file name or path includes a space, you must enclose the file name or path in quotation marks. For example, type `put "c:\My Documents\LJ\CP4520FW.PDF"`

The following series of messages appears in the command window:

200 PORT command successful

150 Opening BINARY mode data connection

226 Ready

226 Processing Job

10. Press **Enter** on the keyboard.
11. The print-ready file prints.
12. At the command prompt, type `bye` to exit the FTP command.
13. At the command prompt, type `exit` to return to the Windows interface.

Print-ready printing by using a local Windows port

To print directly by using a local Windows port, follow the instructions for your operating system.

Windows 2000, Windows XP, Windows Server 2003, Windows Server 2008, or Windows Vista

The print-ready file can be sent directly to the product by typing a `copy` command at a command prompt or in an MS-DOS window.

1. At a command prompt, type `copy /b <FILENAME> <PORTNAME>`, where `<FILENAME>` is the name of the print-ready file (including the path) and `<PORTNAME>` is the name of the appropriate printer port (such as LPT1). For example, type the following:

```
C:\>copy /b c:\CP4520FW.PDF lpt1
```

2. Press **Enter** on the keyboard.

 **NOTE:** If the file name or path includes a space, you must enclose the file name or path in quotation marks. For example, type `C:\>copy /b "c:\My Documents\CP4520FW.PDF"`. The message **PROCESSING JOB** appears on the control panel, and the job prints.

3. At the command prompt, type `exit` to close the command window.

Print-ready file printing in a Windows network

If the product is shared on a Windows network, complete the following steps.

1. From a command prompt or in an MS-DOS window, type `copy /b <FILENAME> \<COMPUTERNAME>\<SHARENAME>`, where `<FILENAME>` is the name of the print-ready file (including the path), `<COMPUTERNAME>` is the name of the computer from which the product is being shared, and `<SHARENAME>` is the product share name. For example, type the following:

```
C:\>copy /b c:\CP4520FW.PDF \\your_server\sharename
```

 **NOTE:** If the file name or path includes a space, you must enclose the file name or path in quotation marks. For example, type `C:\>copy /b "c:\My Documents\CP4520FW.PDF" \
\your_server\sharename`

2. Press **Enter** on the keyboard. The message **PROCESSING JOB** appears on the control panel, and the job prints. The message **1 file(s) copied** appears on the computer screen.

Print-ready file printing by using the LPR command

 **NOTE:** This direct printing method is for use in Windows 2000, Windows XP, Windows Server 2003, Windows Server 2008, and Windows Vista.

Complete the following steps to print a print-ready file by using the LPR command.

1. Make note of the TCP/IP address on the Embedded Jetdirect page. The HP Embedded Jetdirect page is the second page of the configuration page printout. To print a configuration page, see [Determining the current level of firmware on page 198](#).

2. From a command window, type the following:

```
lpr -P <IPADDRESS> -S <IPADDRESS> -o l <FILENAME>
```

or

```
lpr -S <IPADDRESS> -Pbins <FILENAME>
```

where IPADDRESS can be either the TCP/IP address or the host name of the product, and where FILENAME is the file name of the print-ready file.

 **NOTE:** The parameter (-o l) consists of a lowercase "O", not a zero, and a lowercase "L", not the numeral 1. This parameter sets the transport protocol to binary mode.

3. The file prints, but no messages appear in the command prompt window.
4. Type `exit` at the command prompt to close the command window.

Print-ready file printing by using FTP on a direct network connection (Macintosh)

If the HP Color LaserJet Enterprise CP4020-CP4520 Series uses a direct network connection, use file transfer protocol (FTP) to print a print-ready file. Complete the following steps for the operating system:

1. Make note of the TCP/IP address on the Embedded Jetdirect page. The HP Embedded Jetdirect page is the second page of the configuration page printout. To print a configuration page, see [Determining the current level of firmware on page 198](#).

2. Open a Terminal window on your Macintosh. You can find the Terminal program on the computer in the following location:

System/Applications/Utilities/Terminal

Open the Finder, select **Applications**, and then click **Utilities**. Double-click to open the Terminal utility.

3. Type `FTP <TCP/IP product ADDRESS>`. For example, if the TCP/IP address is 192.168.0.90, type the following:

```
FTP 192.168.0.90
```

4. Press **Enter** on the keyboard.

5. When prompted for a user name and password, press **Enter**.

6. You can drag and drop the firmware file into the Terminal folder (System/Applications/Utilities/Terminal). Alternatively, you can type `put <path>`, where <path> is the location where the print-ready file was downloaded from the Web. For example, type the following:

```
put /username/desktop/CP4520FW.PDF
```

 **NOTE:** If the file name or path includes a space, you must enclose the file name or path in quotation marks. For example, type `put "/user name/desktop/CP4520FW.PDF"`

To ensure that the entire path to the print-ready file is placed in the `put` command, type `put` and a space, and then click and drag the print-ready file onto the terminal window. The complete path to the file is automatically placed after the `put` command.

7. Press **Enter**.
8. The download process begins and the firmware is updated on the product. This can take about five minutes. Let the process finish without further interaction with the product or computer.
9. The product automatically turns off and on again to activate the update.

Print-ready file printing in UNIX systems

For UNIX systems, any command method that delivers the print-ready file to the product is acceptable, including the following:

- At the command prompt, type `cp </home/yourmachine/FILENAME/ dev/parallel>`, where `</home/yourmachine/FILENAME>` is the location of the print-ready file.

Special paper guidelines

For more information on Special paper guidelines; Supported paper sizes; Supported paper types; Tray and bin capacity; and Paper orientation see the User Guide at the following links: www.hp.com/go/cljcp4525_manualse and www.hp.com/go/cljcp4025_manualse.

Media attributes and commands

This section includes the following information about paper attributes:

- [Paper-source commands](#)
- [Paper-type commands](#)

Paper-source commands

The PCL 6 Print driver attribute for paper source is `ubyte # MediaSource` or `ubyte_array "string" MediaSource`. See the following table for values of #. For example, "ubyte 4 MediaSource" is the command for Tray 2.

The PCL 5 print driver escape sequence for paper source is `Esc&l#H` (the "l" is a lowercase "L" rather than the numeral "1"). See the following table for values of #. For example, `Esc&l1H` is the command for Tray 2.

 **NOTE:** The HP Color LaserJet Enterprise CP4020-CP4520 Series products support Tray 1, Tray 2, and Tray 3 only.

Table 6-4 Paper-source commands ¹

Input source	PCL 5 <code>Esc&l#H</code>	PCL 6 <code>ubyte # MediaSource ²</code>	PCL 6 <code>ubyte_array "string" MediaSource</code>	PostScript <code>/MediaPosition # or null/ ManualFeed true or false</code>
Automatically select	NA	NA	NA	NA
Printer auto select	7	1	AUTOSELECT	null false
Manual feed in tray 1	2	2	MANUALFEED	3 true
Tray 1 (100-sheet)	4	3	TRAY1	3 false
Tray 2 (250-sheet)	1	4	TRAY2	0 false
Tray 3 (500-sheet)	5	5	TRAY3	1 false
Tray 4 ¹	8	7	TRAY4	4 false
Tray 5 ¹	9	None	TRAY5	38 false
Tray 6 ¹	NA	None	TRAY6	39 false
Tray 7 ¹	NA	None	TRAY7	40 false
Tray 8 ¹	NA	None	TRAY8	41 false
Tray 9 ¹	NA	None	TRAY9	42 false
Tray # ³	20 to 39	8 to 55	TRAY# (# depends on the number of internal trays)	5 to 37 false

Table 6-4 Paper-source commands ¹ (continued)

Input source	PCL 5	PCL 6	PCL 6	PostScript
	Esc&l#H	ubyte # MediaSource ²	ubyte_array "string" MediaSource	/MediaPosition # or null/ ManualFeed true or false
Envelope feeder ¹	6		ENVELOPETRAY	2 false

¹ Trays 4 through 9 and the envelope feeder are not options for the HP Color LaserJet Enterprise CP4020-CP4520 Series products. The options are included in this table only to show what the Universal Print Driver (UPD) generally supports.

² For the string value, you must include the quotation marks around the variable. For example, `ubyte_array "TRAY2"`
MediaSource is the PCL 6 command for Tray 2.

³ Refers to optional trays.

Paper-type commands

The PCL 5 print driver escape sequence for paper type is "Esc&n#Wdpapertype", where "n#" is the number of characters in the paper type plus 1. For example, in the sequence "Esc&n6WdPlain", "Plain" has 5 letters plus 1, for a total of 6.

Table 6-5 paper-type commands

Esc&	n#	Wd	Paper type
Esc&	6	Wd	Plain
Esc&	11	Wd	Preprinted
Esc&	11	Wd	Letterhead
Esc&	13	Wd	Transparency ¹
Esc&	11	Wd	Prepunched
Esc&	7	Wd	Labels
Esc&	5	Wd	Bond
Esc&	9	Wd	Recycled
Esc&	6	Wd	Color
Esc&	6	Wd	Light
Esc&	13	Wd	Interpaperte
Esc&	6	Wd	Heavy
Esc&	12	Wd	Extra Heavy
Esc&	11	Wd	Cardstock ²
Esc&	6	Wd	Rough
Esc&	7	Wd	Glossy
Esc&	12	Wd	Tough Paper
Esc&	9	Wd	Envelope

¹ You must spell out the word "Transparency" in the string, although it is abbreviated as TRNSPRNCY on the control panel.

² The correct command for cardstock is "Esc&n11WdCard Stock", with a space between the "d" and the "S", and with an uppercase "S".

Installation notes

- [I. INTRODUCTION](#)
- [II. LATE-BREAKING INFORMATION](#)
- [III. INSTALLATION INSTRUCTIONS](#)
- [IV. TECHNICAL ASSISTANCE](#)
- [V. LEGAL STATEMENTS](#)

I. INTRODUCTION

PURPOSE OF THIS DOCUMENT

This document provides specific installation instructions and other information you should know before you install and use the printing-system software. The installation instructions are for the following operating systems:

- Windows XP
- Windows Server 2003
- Windows Server 2008
- Windows Vista
- Windows 7
- Mac OS X v10.4 and later

For information about Linux printer drivers, go to www.hp.com/go/linuxprinting.

For more information about the device and printer-driver features, see the *HP Color LaserJet Enterprise CP4020/CP4520 Series Printers User Guide* and the online help included with each software component.

WHO NEEDS THIS SOFTWARE?

All users require this printing-system software. Network clients need the installation CD, or the name of the appropriate network directory, to install the software on their individual workstations.

SYSTEM REQUIREMENTS

The following are compatible system requirements for Windows and Macintosh:

- CD-ROM or DVD drive, or Internet connection
- Dedicated universal serial bus (USB 1.1 or 2.0) connectivity port, or network connection
- Windows Server 2003 and Windows Server 2008: 220 MB of available hard-disk space
- Mac OS X: 150 MB of available hard disk space

OVERVIEW OF THE PRINTING-SYSTEM COMPONENTS

The CD that is included with the product has software for Windows operating systems and Apple Macintosh systems. For more information about a particular printer driver or software component, see the associated online help.

Network administrator software components

HP Web Jetadmin

Network administrators can use HP Web Jetadmin to configure and manage HP products across a variety of operating systems.

 **NOTE:** HP Web Jetadmin is not included on the software CD. Network administrators can download the HP Web Jetadmin software at the following Web site:

www.hp.com/go/webjetadmin

HP Printer Utility for Mac OS X

Network administrators can use the HP Utility for Macintosh OS X v10.4 and later to configure and manage HP products from the computer. The printing-system software CD-ROM includes the HP Printer Utility as part of the driver install.

HP Driver Deployment Utility for Windows operating systems

The printing-system software CD includes the HP Driver Deployment Utility as one of the installer options. Network administrators can use this utility to create a custom printer-driver installation package that includes organization-specific components. Select the components from the printing-system software CD. If the selected printer drivers support preconfiguration, you are prompted to preconfigure the printer-driver settings. Upon completion, the customization utility produces an executable file (*.EXE) and a *.CAB file. Use these files to install the preconfigured printer drivers on client machines. This utility supports silent, batch operations. To gain access to the customization utility, select **Advanced Install Options** on the first CD browser screen, select **Administrator Software** on the second screen, and then select **Driver Deployment Utility**.

For more information and to download the latest version, go to www.hp.com/go/ddu.

Update Now

If you have modified the configuration of the product since installation, the driver can be automatically updated with the new configuration in environments that support bidirectional communication. In the **Printers and Faxes** folder, right-click the printer and select **Properties**. On the **Device Settings** tab, click **Automatic Configuration**, and then select **Update Now**. This automatically captures the new configuration in the driver.

End-user software components

Printer drivers

A printer driver is a software program that other software programs use to gain access to the product features. Typically, you install one printer driver for each product. The printing-system software CD that came with your product includes the following printer driver:

- PCL 6

The most recent printer drivers and printing-system software are available at the following Web sites:

- www.hp.com/go/cljcp4025_software
- www.hp.com/go/cljcp4525_software

Additional printer drivers might be available from an HP distributor or from online sources. See the "TECHNICAL ASSISTANCE" section of this document or see the user guide for more information about obtaining printer drivers and other HP software.

Product documentation

A basic version of the user guide is located in the following places:

- On the printing-system software CD, in the **Manuals** folder
- Click the **User Documentation** button on the CD Browser Home screen



NOTE: Some documents are not available in all languages on the CD. Please check the following Web sites for more documentation and information:

www.hp.com/support/cljcp4025

www.hp.com/support/cljcp4525

To see the expanded version of the user guide, go to the following Web sites and select the **Manuals** link.

- www.hp.com/support/cljcp4025 or www.hp.com/support/cljcp4025_manuals
- www.hp.com/support/cljcp4525 or www.hp.com/support/cljcp4525_manuals

Uninstall

Use the uninstall utility to select and remove any or all of the Windows HP printing-system components. See the "UNINSTALLER" section in this document for more instructions.

Latest printer drivers

The latest printer drivers and product software are available at the following Web site:

- www.hp.com/go/cljcp4025_software
- www.hp.com/go/cljcp4525_software

II. LATE-BREAKING INFORMATION

KNOWN ISSUES, ISSUES FIXED, AND WORKAROUNDS

An updated listing of known issues for the printing-system software is available at the following Web site:

- www.hp.com/support/cljcp4025
- www.hp.com/support/cljcp4525

Click the **Release Notes** or **Readme File** links on the printer-driver download page for the appropriate operating system and the printer-driver version.

III. INSTALLATION INSTRUCTIONS

In a Windows environment, the CD setup or installation software detects the version of the operating system that you are running. The software is installed in the language that you select. For example, if you are running an English version of Windows and have the language preference set to Spanish, the installation utility installs the Spanish version of the printing software for the appropriate Windows version.

WINDOWS INSTALLATION OPTIONS

The following methods are available for installing printer drivers and software components.

- **Install Now.** This method installs the drivers and software. Recommended for most users.
- **Advanced Install Options.** Provides flexibility for installing your choice of drivers and software. Recommended for advanced users and system administrators.

INSTALL SOFTWARE ON WINDOWS XP, WINDOWS SERVER 2003, WINDOWS SERVER 2008, WINDOWS VISTA, AND WINDOWS 7 SYSTEMS

 **NOTE:** Connecting the product to the computer using a USB cable before installing software, also called “Plug and Play,” is *not* recommended. See the installation guide for more information.

NOTE: Administrator privileges are required to install the printing system on all Windows operating systems.

Printing-system installation from the CD or Internet download for network and USB connections

1. Quit all programs.
2. Insert the CD.
 - a. When the main menu appears, click **Install Now**.
 - b. Follow the onscreen instructions.
3. If the HP printing-system installer program has not started after 30 seconds, complete steps 4 through 8.
4. On the **Start** menu, select **Run**. (From a Vista computer, click **Start, All Programs, Accessories**, and then **Run**.)
5. Browse to the root directory for the CD drive.
6. Select the SETUP.EXE file. Click **Open**, and then click **OK**.
7. When the main menu appears, click **Install Now**.
8. Follow the onscreen instructions.

 **NOTE:** If you download the printing-system or driver from the Internet, you might need to first run the EXE file(s). If SETUP.EXE does not run automatically, browse to its root location, double-click the file, and follow the onscreen instructions.

Port selection

When the installation process is complete, you might need to assign the product to a port on your network if you did not assign a port during setup. Perform one of the following procedures:

Windows XP, Windows Server 2003, or Windows Server 2008

1. Click **Start**, select **Settings**, select **Control Panel**, and then select **Printers**.
2. Select the printer that you just installed.
3. On the toolbar, click **File**.
4. Click **Properties**.
5. Click the **Port** tab to change the port information.

Windows Vista and Windows 7

1. Click **Start**, click **Control Panel**, and then in the category for **Hardware and Sound**, click **Printers** or **Devices and Printers**.
2. Right-click the printer that you just installed.
3. Click **Printer Properties**.
4. Click the **Port** tab to change the port information.

Printer driver only (Add Printer) - Windows XP, Windows Server 2003, and Windows Server 2008

1. Close all programs.
2. Click **Start**, click **Settings**, click **Control Panel**, and then click **Printers**.
3. Click **Add (a) printer**.
4. Answer the questions in the Add Printer Wizard until you reach the screen that shows the printer manufacturer list.
5. Click **Have Disk**.
6. Browse to the printer driver location using one of the following options:
 - **CD-ROM:** Browse to the \DRIVERS\[OS][PDL] directory for your operating system on the software CD.
 - **Internet download:** Browse to the folder where the Web files were downloaded and decompressed.
7. Select the appropriate INF file.
8. Click **Open**, and then click **OK**.
9. Select the appropriate printer.
10. Follow the remaining onscreen instructions to complete the printer installation.

Printer driver only (Add Printer) - Windows Vista and Windows 7

1. Close all programs.
2. Click **Start**, click **Control Panel**, and then click **Hardware and Sound**.
3. Under the **Printers** or **Devices and Printers** section, click **Add a printer**.

4. Select **Add Local Printer** and either use an existing port or create a new port.
 - a. For a new port, select **Standard TCP/IP**.
 - b. Enter the **IP Address** or **Host Name**.
5. Answer the questions in the Add Printer Wizard until you reach the screen that shows the printer manufacturer list.
6. Click **Have Disk**.
7. Browse to the printer driver location using one of the following options:
 - **CD-ROM:** Browse to the \DRIVERS\[OS]\[PDL] directory for your operating system on the software CD.
 - **Internet download:** Browse to the folder where the Web files were downloaded and decompressed.
8. Select the appropriate INF file.
9. Click **Open**, and then click **OK**.
10. Select the appropriate printer.
11. Follow the remaining onscreen instructions to complete the printer installation.

UNINSTALLER

Start the Uninstaller - Windows XP, Windows Server 2003, and Windows Server 2008

1. Click **Start**, select **Settings**, select **Control Panel**, and then select **Add or Remove Programs**.
2. Select the HP Color LaserJet CP4020 or CP4520 driver or software component, and then click **Remove**.
3. Follow the onscreen instructions to remove some or all of the printing-system components.

Start the Uninstaller - Windows Vista and Windows 7

1. Windows Vista: Click **Start**, click **Control Panel**, and then click **Programs and Features**.
Windows 7: Click **Start**, click **Control Panel**, click **Programs**, and then click **Programs and Features**.
2. Select the HP Color LaserJet CP4020 or CP4520 driver or software component, and then click **Uninstall/Change**.
3. Follow the onscreen instructions to remove some or all of the printing-system components.

INSTALL MACINTOSH SOFTWARE FOR DIRECT CONNECTIONS (USB)

1. Make sure the product is turned on.
2. Insert the CD into the CD-ROM drive. If the CD does not run automatically, double-click the CD icon on the desktop.
3. Double-click the **hpclj CP4020.mpkg** or the **hpclj CP4520.mpkg** icon in the HP LaserJet Installer folder.

4. Follow the instructions on the computer screen.
5. Connect a USB cable between the product USB port and the computer USB port. Use a standard 2-meter (6.56-foot) USB cable.

 **NOTE:** USB printer queues are created automatically when the product is attached to the computer. However, the queue will use a generic PPD if the installer has not been run before the USB cable is connected.

6. From the Apple menu, click **System Preferences** and then **Print & Fax**.
7. If the product name appears in the Printer list, setup is complete. If the product name does not appear in the printer list, continue with the next step.
8. Click **Add** or **+**, and then select **Default Browser** or **Default**. Select the product name from the Printer Browser.
9. Click **Add**. The **Installable Options** dialog box appears. Select the product options that you are using.
10. Print a test page from any software program to make sure that the software is correctly installed.

INSTALL MACINTOSH SOFTWARE FOR NETWORKS

1. Connect the network cable between the HP Jetdirect print server and a network port.
2. Insert the CD into the CD-ROM drive. If the CD does not run automatically, double-click the CD icon on the desktop.
3. Double-click the **hpcij CP4020.mpkg** or the **hpcij CP4520.mpkg** icon in the HP LaserJet Installer folder.
4. Follow the instructions on the computer screen.
5. From the Apple menu, click **System Preferences** and then **Print & Fax**.
6. Click **Add** or **+**.
7. Select the connection type:
 - **Default Browser**
 - a. Select the product from the list.
 - b. From the **Print Using** drop-down list, select the printer model if one is not already selected.
 - **IP Printing**
 - a. From the Protocol drop-down list, select **Socket/HP Jetdirect**.
 - b. Enter the IP address for the product.
 - c. From the **Print Using** drop-down list, select the printer model if one is not already selected.
8. Click **Add**. The **Installable Options** dialog box appears. Select the product options that you are using.
9. Print a test page from any software program to make sure that the software is correctly installed.

IV. TECHNICAL ASSISTANCE

CUSTOMER SUPPORT

See the user guide or the in-box flyer, or call your local authorized HP dealer.

WEB

Online technical support is available at the following Web sites:

- www.hp.com/support/cljcp4025
- www.hp.com/support/cljcp4525
- www.hp.com/go/bizsupport
- www.hp.com/go/support

HP SOFTWARE AND SUPPORT SERVICES - ADDITIONAL INFORMATION

See either the user guide or the in-box flyer for additional methods of obtaining software and support information, such as printer-driver distribution centers, other online services, fax services, and other online support.

V. LEGAL STATEMENTS

OPEN-SOURCE SOFTWARE LICENSE AGREEMENTS (In English)

Apache License

Version 2.0, January 2004

www.apache.org/licenses/

TERMS AND CONDITIONS FOR USE, REPRODUCTION, AND DISTRIBUTION

1. Definitions.

"License" shall mean the terms and conditions for use, reproduction, and distribution as defined by Sections 1 through 9 of this document.

"Licensor" shall mean the copyright owner or entity authorized by the copyright owner that is granting the License.

"Legal Entity" shall mean the union of the acting entity and all other entities that control, are controlled by, or are under common control with that entity. For the purposes of this definition, "control" means (i) the power, direct or indirect, to cause the direction or management of such entity, whether by contract or otherwise, or (ii) ownership of fifty percent (50%) or more of the outstanding shares, or (iii) beneficial ownership of such entity.

"You" (or "Your") shall mean an individual or Legal Entity exercising permissions granted by this License.

"Source" form shall mean the preferred form for making modifications, including but not limited to software source code, documentation source, and configuration files.

"Object" form shall mean any form resulting from mechanical transformation or translation of a Source form, including but not limited to compiled object code, generated documentation, and conversions to other media types.

"Work" shall mean the work of authorship, whether in Source or Object form, made available under the License, as indicated by a copyright notice that is included in or attached to the work (an example is provided in the Appendix below).

"Derivative Works" shall mean any work, whether in Source or Object form, that is based on (or derived from) the Work and for which the editorial revisions, annotations, elaborations, or other modifications represent, as a whole, an original work of authorship. For the purposes of this License, Derivative Works shall not include works that remain separable from, or merely link (or bind by name) to the interfaces of, the Work and Derivative Works thereof.

"Contribution" shall mean any work of authorship, including the original version of the Work and any modifications or additions to that Work or Derivative Works thereof, that is intentionally submitted to Licensor for inclusion in the Work by the copyright owner or by an individual or Legal Entity authorized to submit on behalf of the copyright owner. For the purposes of this definition, "submitted" means any form of electronic, verbal, or written communication sent to the Licensor or its representatives, including but not limited to communication on electronic mailing lists, source code control systems, and issue tracking systems that are managed by, or on behalf of, the Licensor for the purpose of discussing and improving the Work, but excluding communication that is conspicuously marked or otherwise designated in writing by the copyright owner as "Not a Contribution."

"Contributor" shall mean Licensor and any individual or Legal Entity on behalf of whom a Contribution has been received by Licensor and subsequently incorporated within the Work.

2. Grant of Copyright License.

Subject to the terms and conditions of this License, each Contributor hereby grants to You a perpetual, worldwide, non-exclusive, no-charge, royalty-free, irrevocable copyright license to reproduce, prepare Derivative Works of, publicly display, publicly perform, sublicense, and distribute the Work and such Derivative Works in Source or Object form.

3. Grant of Patent License.

Subject to the terms and conditions of this License, each Contributor hereby grants to You a perpetual, worldwide, non-exclusive, no-charge, royalty-free, irrevocable (except as stated in this section) patent license to make, have made, use, offer to sell, sell, import, and otherwise transfer the Work, where such license applies only to those patent claims licensable by such Contributor that are necessarily infringed by their Contribution(s) alone or by combination of their Contribution(s) with the Work to which such Contribution(s) was submitted. If You institute patent litigation against any entity (including a cross-claim or counterclaim in a lawsuit) alleging that the Work or a Contribution incorporated within the Work constitutes direct or contributory patent infringement, then any patent licenses granted to You under this License for that Work shall terminate as of the date such litigation is filed.

4. Redistribution.

You may reproduce and distribute copies of the Work or Derivative Works thereof in any medium, with or without modifications, and in Source or Object form, provided that You meet the following conditions:

- a. You must give any other recipients of the Work or Derivative Works a copy of this License; and
- b. You must cause any modified files to carry prominent notices stating that You changed the files; and
- c. You must retain, in the Source form of any Derivative Works that You distribute, all copyright, patent, trademark, and attribution notices from the Source form of the Work, excluding those notices that do not pertain to any part of the Derivative Works; and
- d. If the Work includes a "NOTICE" text file as part of its distribution, then any Derivative Works that You distribute must include a readable copy of the attribution notices contained within such NOTICE file, excluding those notices that do not pertain to any part of the Derivative Works, in at least one of the following places: within a NOTICE text file distributed as part of the Derivative Works; within the Source form or documentation, if provided along with the Derivative Works; or, within a display generated by the Derivative Works, if and wherever such third-party notices normally appear. The contents of the NOTICE file are for informational purposes only and do not modify the License. You may add Your own attribution notices within Derivative Works that You distribute, alongside or as an addendum to the NOTICE text from the Work, provided that such additional attribution notices cannot be construed as modifying the License.

You may add Your own copyright statement to Your modifications and may provide additional or different license terms and conditions for use, reproduction, or distribution of Your modifications, or for any such Derivative Works as a whole, provided Your use, reproduction, and distribution of the Work otherwise complies with the conditions stated in this License.

5. Submission of Contributions.

Unless You explicitly state otherwise, any Contribution intentionally submitted for inclusion in the Work by You to the Licensor shall be under the terms and conditions of this License, without any additional terms or conditions. Notwithstanding the above, nothing herein shall supersede or modify the terms of any separate license agreement you may have executed with Licensor regarding such Contributions.

6. Trademarks.

This License does not grant permission to use the trade names, trademarks, service marks, or product names of the Licensor, except as required for reasonable and customary use in describing the origin of the Work and reproducing the content of the NOTICE file.

7. Disclaimer of Warranty.

Unless required by applicable law or agreed to in writing, Licensor provides the Work (and each Contributor provides its Contributions) on an "AS IS" BASIS, WITHOUT WARRANTIES OR CONDITIONS OF ANY KIND, either express or implied, including, without limitation, any warranties or conditions of TITLE, NON-INFRINGEMENT, MERCHANTABILITY, or FITNESS FOR A PARTICULAR PURPOSE. You are solely responsible for determining the appropriateness of using or redistributing the Work and assume any risks associated with Your exercise of permissions under this License.

8. Limitation of Liability.

In no event and under no legal theory, whether in tort (including negligence), contract, or otherwise, unless required by applicable law (such as deliberate and grossly negligent acts) or agreed to in writing, shall any Contributor be liable to You for damages, including any direct, indirect, special, incidental, or consequential damages of any character arising as a result of this License or out of the use or inability to use the Work (including but not limited to damages for loss of goodwill, work stoppage, computer failure or malfunction, or any and all other commercial damages or losses), even if such Contributor has been advised of the possibility of such damages.

9. Accepting Warranty or Additional Liability.

While redistributing the Work or Derivative Works thereof, You may choose to offer, and charge a fee for, acceptance of support, warranty, indemnity, or other liability obligations and/or rights consistent with this License. However, in accepting such obligations, You may act only on Your own behalf and on Your sole responsibility, not on behalf of any other Contributor, and only if You agree to indemnify, defend, and hold each Contributor harmless for any liability incurred by, or claims asserted against, such Contributor by reason of your accepting any such warranty or additional liability.

END OF TERMS AND CONDITIONS

TRADEMARK NOTICES

Microsoft®, Windows®, Windows XP®, and Windows Vista® are U.S. registered trademarks of Microsoft Corporation.

SOFTWARE WARRANTY, LICENSE, AND COPYRIGHT

Warranty

See the user guide for complete warranty and support information.

License

See the user guide for complete information about HP software license terms.

Copyright

© 2009 Copyright Hewlett-Packard Development Company, L.P.

Reproduction, adaptation or translation without prior written permission is prohibited, except as allowed under the copyright laws.

The information contained herein is subject to change without notice.

The only warranties for HP products and services are set forth in the express warranty statements accompanying such products and services. Nothing herein should be construed as constituting an additional warranty. HP shall not be liable for technical or editorial errors or omissions contained herein.

Index

A

- accessibility features 4
- accessories, automatic configuration 27
- Add Printer installation 53
- Add Printer Wizard, detailed install
 - existing port for a direct connection, using 57
 - print server connection 57
 - TCP/IP port for direction connection, creating 58
- administrator
 - documentation 9
- Adobe Acrobat Reader
 - printing PDF files without 213
 - viewing documentation 6
- Advanced Installation
 - choosing 23
- alerts, e-mail
 - Macintosh 191
- Alternative Letterhead Mode
 - supported products 108
- Apple Mac OS
 - see Macintosh OS 25
- autoconfiguration, driver support for 27
- autoconfiguration, Enterprise
 - about 27
 - Windows support 28
- autorun CD, Windows 23

B

- Back button, Windows installation
 - dialog boxes 86
- bidirectional communication
 - about 27
 - Enterprise
 - AutoConfiguration 27

- bins, output
 - capacity 3
 - locating 17
- blank or preprinted pages
 - options xiv
- booklet printing
 - Booklet Layout settings 138

C

- Cancel button, Windows installation
 - dialog boxes 86
- capacity
 - output bins 3
- cardstock, paper type
- commands 220
- CD
 - directory structure, Macintosh 12
 - directory structure, Windows 12
 - documentation 6, 24
 - installer, Windows printing-system software 22
 - languages 6
 - Macintosh printing-system software installation 170
- CD-ROM
 - installing Windows printing-system software 56
- chapter separator pages 124
- CHM files
 - viewing 6
- Color
 - Color Options settings 150
 - Color Themes settings 153
 - Custom Profile setting 153
 - Default (sRGB) setting 153
 - features, print drivers 149
 - Neutral Gray settings 152
 - None 153

- Photo (Adobe RGB 1998)
 - setting 153
- Photo (sRGB) setting 153
- Vivid setting 153
- color
 - change default settings, manually 150
 - Edge Control settings 152
 - enable access 11
 - fine-tune default settings 150
 - Halftone setting 152
 - PANTONE color profiles 35
 - printing settings, controlling 34
 - restricting printing 34
 - track usage 11
- color printing
 - access and usage 11
 - ICC profiles 35
 - Pantone color profiles 35
- Color Usage log, Macintosh 184
- command-line printing, Windows 213
- common installer, features 24
- components, software
 - Macintosh 169
- configuration, driver 11
- configurations, models 5
- connectivity
 - bidirectional communication support 27
 - features 4
- constraint messages
 - print drivers 103
- continuous export 32
- control panel
 - locating 17
- copies
 - Quick Copy setting 145

- covers
 - settings 122
- covers, locating 17
- custom paper types
 - adding 122
- D**
- DDU
 - see HP Driver Deployment Utility 31
- default printer, setting 96
- device connection
 - installation xiii
- Device Status screen
 - EWS 157
- diagnostics
 - troubleshoot 156
- dialog boxes, printing-system software installation
 - Mac OS X 170
- direct printing
 - FTP, Mac 216
 - FTP, Windows 214
 - local port, Windows 214
 - LPR 215
 - networks, Windows 215
 - UNIX 217
- direct-connect installation 56
- directory structure, software CD
 - Macintosh 12
 - Windows 12
- disabling
 - driver features 31
- disk space requirements
 - Macintosh 168
- documentation
 - administrator 9
 - availability by operating system xi
 - color printing access and usage 11
 - file formats 6
 - HP driver configuration 11
 - HP Jetdirect 10
 - HP Jetdirect Administrator's Guide 10
 - install notes 8
 - languages xi
 - user guide 7
 - viewing 6, 24

- download
 - firmware 198
- drivers
 - accessory configuration 27
 - Add Printer installation 53
 - Automatic Configuration
 - setting 142
 - changing settings (Mac) 168
 - changing settings (Windows) 100
 - continuous export feature 32
 - diagnostics 33
 - Enterprise
 - AutoConfiguration 27
 - HP Driver Configuration User Guide 11
 - HP Driver Preconfiguration
 - support xi
 - included 25
 - languages xi
 - license agreement, installation 71
 - Linux OS 55
 - lockable features 31
 - network configuration 11
 - Point and Print installation 62
 - UNIX OS 55
 - Update Now, bidirectional communication 142
- drivers, install
 - license agreement 80
- duplexing
 - supported products 113
 - Tray 3 163

- E**
- e-mail alerts
 - Macintosh 191
- Easy Printer Care
 - about 35
- embedded Web server 34
- Enterprise AutoConfiguration
 - about 27
 - Novell NetWare operating systems supported xi
 - Windows operating systems supported 28
- envelopes, paper type
 - commands 220

- escape sequences
 - paper source 219
 - paper type 220
- Ethernet cards 4
- exporting driver parameters 32
- F**
- features 3, 5
- File Upload, Macintosh 185
- firmware
 - determine current level 198
 - download 198
 - FTP updates, Windows 202
 - HP Web Jetadmin
 - updates 209
 - LPR command updates 206
 - Macintosh updates 185
 - messages during update 199
 - remote update,
 - Macintosh 185
 - troubleshoot updates 199
 - UNIX updates 212
 - update remotely 198
 - upload, HP Printer Utility 185
 - verifying installation 200
 - Windows network
 - updates 205
 - Windows, local port
 - update 203
- fonts
 - included 3
 - install/remove external fonts 159
 - Macintosh 169
 - Send True Type as Bitmap, print drivers 107
 - supported by Windows 37
 - True Type, print drivers 106
 - Upload Fonts, HP Printer Utility 187
 - upload, Configuration Settings menu 187
 - Windows 39
- FTP
 - direct printing, Mac 216
 - direct printing, Windows 214
 - Windows firmware
 - updates 202

G

guides. *See* documentation

H

heavy paper, paper type

commands 220

help

Macintosh 169

print drivers 103

Help button, Windows installation

dialog boxes 86

HP (Printer) Utility, Macintosh

access 181

HP Driver Configuration 11

HP Driver Deployment Utility

common problems 50

HP Driver Deployment Utility

(DDU) 31

HP Driver Diagnostic Printer Check

Tool 33

HP Driver Installation Utility

(HPDIU)

device connection options xiv

for advanced installations 78

HP Driver Preconfiguration

HP Driver Configuration

Editor 30

HP Web Jetadmin Driver

Configuration Plugin 31

OS and drivers supported xi

support guide 31

HP Easy Printer Care

see Easy Printer Care 35

HP Embedded Web Server

HP Printer Utility, accessing

from 196

Macintosh support 169

HP Jetdirect

documentation 10

HP Jetdirect print server

models including 5

HP PCL 5 Universal Print Driver

HP Driver Preconfiguration

support xi

included 25

HP PCL 6 Print Driver

features 99

HP Driver Preconfiguration

support xi

included 25

settings 99

supported operating

systems 25

HP Printer Utility for Macintosh

firmware update 185

HP Printer Utility, Macintosh

about 181

Color Usage log 184

Device Information 183

E-mail Alerts 191

Embedded Web Server

access 196

File Upload 185

Network Settings 192

Supplies Management 194

trays configuration 189

Upload Fonts 187

HP PS Universal Print Driver

HP Driver Preconfiguration

support xi

included 25

HP PS Universal Print Driver and

PCL Universal Print Driver

supported operating

systems 25

HP Utility, Macintosh

Supplies Status 182

HP Web Jetadmin

downloading 24

firmware updates 209

HTM files

viewing 6

I

ICC profiles. *See* International

Color Consortium profiles

ICM. *See* Image Color

Management

Image Color Management

color graphics printing 106

enabling 106

Incompatible Print Settings

messages. *See* constraint

messages

install notes 8

installation

Add Printer 53

additional options 96

advanced 78

component languages xi

device connection xiii

dialog boxes, Mac OS X 170

HP Driver Installation

Utility 78

Macintosh printing-system

software 170

Point and Print 62

system requirements for

Macintosh 168

troubleshooting

Macintosh 178

Windows printing-system

software 56

installers

common, features 24

Windows 22

interface ports

included 4

locating 18, 19

International Color Consortium

profiles

viewing 35

J

Jetadmin. *See* HP Web Jetadmin

Jetdirect Administrator's

Guide 10

Jetdirect print server

models including 5

Job storage

Macintosh 190

job storage mode

personal job 145

proof and hold 144

L

LAN-connector 4

languages

CD 6

driver xi

installer component xi

languages, printer 3

Linux OS

driver availability 55

local port command line printing,

Windows 214

localized CD 6

lockable features, drivers 31

- LPR commands
 - firmware updates 206
 - printing PDF files 215
- M**
- Mac
 - driver settings 168
 - removing software 180
- Macintosh
 - hardware requirements 168
 - software components 169
 - supported operating systems 168
- Macintosh OS
 - Color Usage log 184
 - Device Information 183
 - dialog boxes, Mac OS X printing-system software
 - installation 170
 - direct printing 213
 - directory structure, software CD 12
 - e-mail alerts 191
 - File Upload command 185
 - firmware upgrades 185
 - fonts supported 169
 - HP EWS 169
 - HP Printer Utility 181
 - install notes 169
 - network settings 192
 - network setup 170
 - online help 169
 - PDEs 169
 - printing-system software
 - installation 170
 - stored jobs 190
 - Supplies Management 194
 - supplies status 182
 - trays configuration 189
 - troubleshooting setup 178
 - Upload Fonts 187
- manuals. See documentation
- memory
 - included 5
 - Macintosh requirements 168
- messages, constraint
 - print drivers 103
- model scripts, UNIX 55
- models, features 5
- mopy 164
- multiple-original print. See mopy
- N**
- networks
 - color printing, restricting 34
 - connectivity features 4
 - direct printing 215
 - firmware updates 205
 - HP Driver Configuration 11
 - HP Jetdirect Administrator's Guide 10
 - Macintosh settings 192
 - Macintosh setup 170
 - Point and Print installation 62
 - print servers included 5
 - Web Jetadmin,
 - downloading 36
 - Windows printing-system software installation 70
- Novell Netware operating systems
 - Enterprise AutoConfiguration support xi
- O**
- on/off button, locating 17
- operating systems
 - Enterprise AutoConfiguration support 28
 - supported 54
- ordering supplies 24
- OS. See operating systems
- output bin
 - capacity 3
 - locating 17
- P**
- package creation
 - suppress user error messages 47
- pages
 - blank or preprinted 123
- Pantone
 - color profile 35
- paper
 - adding custom types 122
 - Alternative Letterhead Mode 108
 - custom sizes 119
 - duplex binding settings, print drivers 137
 - orientation 140
 - settings, print drivers 117
 - source commands 219
 - source setting 120
 - type commands 220
 - type setting 120
 - types and sizes
 - supported 219
- parallel port direct-connect
 - installation 56
- PCL files, command-line printing 213
- PDEs (Printer Dialog Extensions) 169
- PDF files
 - command-line printing 213
 - LPR commands, printing 215
 - Macintosh, File Upload command 185
 - viewing 6
- personal job option
 - job storage 145
- PIN
 - Personal Job setting 145
 - PIN to print setting 146
- Point and Print installation, Windows printing-system software 62
- ports
 - included 4
 - locating 19
- power connection
 - locating 18
- power switch, locating 17
- PPDs, Macintosh
 - troubleshooting 179
- print driver
 - supported operating systems 25
- print drivers
 - About tab contents 166
 - access 100
 - Advanced Printing Features settings, print drivers 107
 - Advanced tab content 105
 - Allow Manual Duplexing setting, Device Settings tab 163
 - Alternative Letterhead Mode, Advanced tab 108
 - Automatic Configuration setting, Device Settings tab 142

Automatic settings, Color tab 150

Booklet Layout settings, Finishing tab 138

collation settings 164

Color Options settings, Color tab 150

Color tab contents 149

Color Themes settings, Color tab 153

continuous export 32

Copy Count settings, Advanced tab 106

device services, Services tab 157

Device Settings tab content 158

Document Options setting, Advanced tab 106

Document Options settings, Finishing tab 134

document preview image 125, 129, 140, 154

duplex unit, Device Settings tab 163

Effects tab content 127

Factory Defaults setting, Printing Shortcuts tab 110

Finishing tab contents 134

Flip Pages Up setting, Finishing tab 137

Font Substitution Table settings, Device Settings tab 159

Form to Tray Assignment setting, Device Settings tab 158

General Everyday Printing setting, Printing Shortcuts tab 110

General settings, Color tab 152

Graphic setting, Advanced tab 106

Halftone setting, Color tab 152

Help system 103

ICM options, Advanced tab 106

incompatible print settings messages 103

installable options, Device Settings tab 137

Internet Services options, Services tab 156

job name settings, Job Storage tab 147

job notification options, Job Storage tab 146

Job Separator setting, Device Settings tab 163

Job Storage Mode settings, Job Storage tab 144

job storage settings, Job Storage tab 147

Job Storage tab contents 142

Layout Options setting, Advanced tab 108

Macintosh 169

Manual settings, Color tab 150

mopier mode, Device Settings tab 164

Neutral Grays settings, Color tab 152

Orientation settings, Finishing tab 140

Page Order settings, Finishing tab 139

Pages per Sheet setting, Finishing tab 138, 139

Paper Options settings, Paper/Quality tab 117

paper source commands 219

Paper source setting, Paper/Quality tab 120

paper supported 219

paper type commands 220

Paper type setting, Paper/Quality tab 120

Paper/Output settings, Advanced tab 105

Paper/Quality tab contents 116

Personal Job setting, Job Storage tab 145

PIN to print setting, Job Storage tab 146

Print All Text as Black setting, Advanced tab 107

Print on Both Sides settings, Finishing tab 135

Print Optimizations setting, Advanced tab 107

Print Quality settings, Paper/Quality tab 126

Printer Features setting, Advanced tab 107

printer hard disk, Device Settings tab 163

Printing Preferences tab, driver access 101

Printing Shortcuts tab contents 109

Proof and Hold setting, Job Storage tab 144

Properties tab, driver access 102

Quick Copy setting, Job Storage tab 145

Raster Compression feature, Advanced tab 107

Resizing Options settings, Effects tab 127

Send True Type as Bitmap setting, Advanced tab 107

Services tab content 156

status message, Job Storage tab 144

Stored Job setting, Job Storage tab 145

tray 3, Device Settings tab 163

tray 4, Device Settings tab 163

tray 5, Device Settings tab 163

True Type font settings, Advanced tab 106

Two-sided (Duplex) Printing setting, Printing Shortcuts tab 114

user name settings, Job Storage tab 146

version numbers 25

Watermarks settings, Effects tab 129

What's this? Help 103

print job delete stored job 148

- hard disk, job storage 163
 - job name settings 147
 - job separator 163
 - job storage 163
 - Personal Job setting 145
 - Proof and Hold setting 144
 - Quick Copy setting 145
 - release stored job 148
 - Stored Job setting 145
 - user name 146
 - print on both sides
 - automatically 135
 - manually 136
 - supported products 113
 - Tray 3 163
 - print pages on different paper settings xiv
 - print-ready files
 - command-line printing 213
 - printing by FTP 213
 - printing by local Windows port 214
 - printing by Windows network 215
 - printing in UNIX systems 217
 - printing with LPR command 215
 - Printer Dialog Extensions (PDEs) 169
 - printer drivers (Mac)
 - changing settings 168
 - printer drivers (Windows)
 - changing settings 100
 - printer languages 3
 - printer, setting default 96
 - printing
 - direct in a Windows network 215
 - direct in UNIX 217
 - direct using FTP 213
 - direct using local Windows port 214
 - direct using LPR command 215
 - user guide 8
 - Printing Shortcuts tab
 - paper size options 112
 - paper type options 111
 - printing-system software
 - availability 12
 - installation 71
 - installation options 23
 - installation, Macintosh 170
 - license agreement, installation 71
 - requirements 54
 - software CD, Windows 22
 - printing-system software, install license agreement 80
 - proof and hold 144
 - PS emulation fonts 39
 - PS files, command-line printing 213
- R**
- Recommended Installation choosing 23
 - regional versions, CD 6
 - remote firmware updates
 - about 198
 - determine current firmware level 198
 - downloading 198
 - FTP, Windows 202
 - HP Web Jetadmin 209
 - LPR commands 206
 - Macintosh 185
 - messages 199
 - troubleshoot 199
 - UNIX 212
 - verifying installation 200
 - Windows network 205
 - Windows, using local port 203
 - removing Mac software 180
 - RFU. *See* remote firmware updates
 - RTF files
 - viewing 6
- S**
- security features 4
 - security slot
 - locating 19
 - settings
 - continuous export 32
 - drivers 100
 - drivers (Mac) 168
 - locking 31
 - software
 - embedded Web server 34
 - uninstalling Mac 180
 - software license agreement 71, 80
 - special media
 - guidelines 218
 - Special Pages
 - covers 122
 - special paper
 - guidelines 218
 - standard output bin
 - capacity 3
 - status
 - Macintosh supplies 182, 194
 - storage, job
 - Macintosh 190
 - supplies
 - Macintosh status 182, 194
 - ordering 24
 - system requirements
 - printing-system software 54
- T**
- TCP/IP port creation 58
 - text files, command-line printing 213
 - transparencies, paper type commands 220
 - trays
 - Alternative Letterhead Mode 108
 - duplex unit 163
 - included 5
 - locating 17
 - Macintosh configuration 189
 - paper source commands 219
 - paper type commands 220
 - specify paper size 158
 - tray 3 163
 - tray 4 163
 - tray 5 163
 - troubleshoot
 - diagnostics 156
 - firmware upgrades 199
 - HP driver Diagnostic Printer Check Tool 33
 - troubleshooting
 - Macintosh setup 178
 - TrueType fonts included 3
 - TXT files, command-line printing 213

typefaces
included 3

U

uninstall
products 97
uninstalling Mac software 180
UNIX OS
direct printing 217
driver availability 55
print-ready printing 217
remote firmware update 212
Update Now feature
steps to activate 29
updating firmware remotely. See
remote firmware update
Upload fonts
Configuration Settings
menu 187
USB direct-connect
installation 56
user guide
HP Driver Configuration 11
print 8
viewing 7

V

version numbers
print drivers 25

W

Web Jetadmin
configuration plugin 31
downloading 36
Web sites
download software 12
firmware download 198
Internet Services options,
Services tab 156
other OS support links 55
support links 24
Windows
driver settings 100
Windows operating systems
Add Printer installation 53
CD, print system 22
default printer, setting 96
Enterprise AutoConfiguration
support 28
fonts supported 37

installing printing-system
software 56

PS emulation fonts
supported 39

Windows OS

direct printing, FTP 213
direct printing, local port 214
direct printing, networks 215
directory structure, software
CD 12
driver versions 25
HP Driver Preconfiguration
support xi
HP PCL 6 Print Driver
features 99
LPR commands 215
Point and Print installation 62
remote firmware update 203
supported 54

