

HP Designjet L25500 Printer series

User's guide (first edition)



Legal notices

© 2009 Hewlett-Packard Development Company, L.P.

The information contained herein is subject to change without notice.

The only warranties for HP Products and services are set forth in the express warranty statement accompanying such products and services. Nothing herein should be construed as constituting an additional warranty. HP shall not be liable for technical or editorial errors or omissions contained herein.

Trademarks

Microsoft® and Windows® are U.S. registered trademarks of Microsoft Corporation.

Table of contents

1 Introduction

Safety precautions	1
The printer's main features	4
The printer's main components	5
The Embedded Web Server	8

2 Connectivity and software instructions

Connection method	10
Connect to a network	10

3 Basic setup options

Printer setup options	11
Embedded Web Server setup options	13

4 Handle the substrate

Overview	15
Load a roll onto the spindle	16
Load a roll into the printer	19
Unload a roll from the printer	22
Use the take-up reel	23
View information about the substrate	31
Store the substrate	31
Download substrate presets	32
Add a new substrate type	32
Color calibration	39
Color profiles	39

5 Handle the ink system

Ink system components	40
Ink system tips	43
Work with ink system components	43
Order ink supplies	58

6 Print options

Printer states	60
Change margins	60

Request the printer's internal prints	61
7 Accessories	
Order accessories	62
8 Printer specifications	
Functional specifications	63
Physical specifications	64
Memory specifications	64
Power specifications	64
Ecological specifications	64
Environmental specifications	65
Acoustic specifications	65
Glossary	66
Index	68

1 Introduction

Safety precautions

Before using your printer, read the following safety precautions to make sure you use the equipment safely.

General safety guidelines

- Refer to installation instructions before connecting the printer to the supply.
- There are no operator-serviceable parts inside the printer. Refer servicing to qualified service personnel.
- Turn off the printer, unplug both power cords from the power outlets, and call your service representative in any of the following cases:
 - The power cord or plug is damaged.
 - Liquid has entered the printer.
 - There is smoke or an unusual smell coming from the printer.
 - The printer has been dropped or the drying or curing module damaged.
 - The printer's built-in Residual Current Circuit Breaker (Ground Fault Circuit Interrupter) has been repeatedly tripped.
 - Fuses have blown.
 - The printer is not operating normally.
- Turn off the printer and unplug both power cords from the power outlets in either of the following cases:
 - During a thunderstorm
 - During a power failure

Electrical shock hazard

⚠ WARNING! The drying and curing modules operate at hazardous voltages capable of causing death or serious personal injury.

The printer uses two power cords. Unplug both power cords before servicing the printer. The printer must be connected to earthed mains outlets only.

To avoid the risk of electric shock:

- Do not attempt to dismantle the drying and curing modules or the electrical control cabinet.
- Do not remove or open any other closed system covers or plugs.
- Do not insert objects through slots in the printer.

 **NOTE:** A blown fuse may indicate malfunctioning electrical circuits within the system. Call your service representative, and do not attempt to replace the fuse yourself.

Heat hazard

The drying and curing subsystems of the printer operate at high temperatures and can cause burns if touched. To avoid personal injury, take the following precautions.

- Do not touch the internal enclosures of the printer's drying and curing modules. Even after opening the window latch that disconnects drying and curing power, the internal surfaces could be hot.
- Take special care when accessing the substrate path.

Fire hazard

The drying and curing subsystems of the printer operate at high temperatures. Call your service representative if the printer's built-in Residual Current Circuit Breaker (Ground Fault Circuit Interrupter) is repeatedly tripped.

To avoid the risk of fire, take the following precautions.

- Use the power supply voltage specified on the nameplate.
- Connect the power cords to dedicated lines, each protected by a branch circuit breaker according to the rating of the wall socket. Do not use a power strip (relocatable power tap) to connect both power cords.
- Use only the power cords supplied by HP with the printer. Do not use a damaged power cord. Do not use the power cords with other products.
- Do not insert objects through slots in the printer.
- Take care not to spill liquid on the printer.
- Do not use aerosol products that contain flammable gases inside or around the printer.
- Do not block or cover the openings of the printer.
- Do not attempt to dismantle the drying or curing module, or the electrical control cabinet.
- Load substrates that can be used at an operating temperature of up to 125°C (257°F), and have auto-ignition temperatures above 250°C (482°F).

Mechanical hazard

The printer has moving parts that could cause injury. To avoid personal injury, take the following precautions when working close to the printer.

- Keep your clothing and all parts of your body away from the printer's moving parts.
- Avoid wearing necklaces, bracelets and other hanging objects.
- If your hair is long, try to secure it so that it will not fall into the printer.
- Take care that sleeves or gloves do not get caught in the printer's moving parts.

- Avoid standing close to the fans, which could cause injury and could also affect print quality (by obstructing the air flow).
- Do not touch gears or moving rolls during printing.

Heavy substrate hazard

Special care must be taken to avoid personal injury when handling heavy substrates.

- Handling heavy substrate rolls may require more than one person. Care must be taken to avoid back strain and/or injury.
- Consider using a forklift, pallet truck or other handling equipment.
- When handling heavy substrate rolls, wear personal protective equipment including boots and gloves.

Ink handling



Your printer does not use solvent inks and does not have the traditional problems associated with them. However, HP recommends that you wear gloves when handling ink system components.



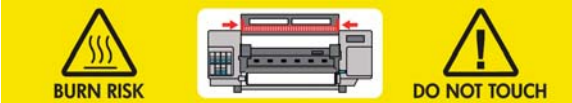

Warnings and cautions

The following symbols are used in this manual to ensure the proper use of the printer and to prevent the printer from being damaged. Follow the instructions marked with these symbols.

- △ **WARNING!** Failure to follow the guidelines marked with this symbol could result in serious personal injury or death.
- △ **CAUTION:** Failure to follow the guidelines marked with this symbol could result in minor personal injury or damage to the product.

Warning labels

Label	Explanation
	Risk of burns. Do not touch the internal enclosures of drying and curing modules of the printer.
	Risk of burns. Do not touch the drying enclosure of the printer. Even after opening the window latch, which disconnects the power to the drying and curing modules, the internal surfaces could be hot.
	Electric shock hazard. The printer has two input power cords. A voltage is still present in the drying and curing modules after the main switch is turned off. There are no operator-serviceable parts inside the printer. Refer servicing to qualified service personnel. Disconnect all power cords before servicing.

Label	Explanation
SEE INSTALLATION INSTRUCTIONS BEFORE CONNECTING TO THE SUPPLY.	See installation instructions before connecting to the supply. Ensure that the input voltage is within the printer's rated voltage range. The printer requires two dedicated lines, each protected by a branch circuit breaker according to the rating of the wall socket outlet. Use only earthed mains outlets and the power cords supplied by HP with the printer.
	Risk of trapped hands. Do not push the roll while loading. Lift the loading table to ease the spindle into the printer.
	Risk of trapped fingers. Do not touch spindle gears while moving.
	Do not put objects on top of the printer. Do not cover the fans.
	You are recommended to wear gloves when handling ink cartridges, printhead cleaning cartridges and the printhead cleaning container.

The printer's main features

Your printer is a color inkjet printer designed for printing high-quality images on flexible substrates from 23 in (584 mm) to 42 or 60 in (1.07 or 1.52 m) wide, depending on which printer model you have. Some major features of the printer are shown below:

- Printing speeds in draft mode of up to 250 ft²/h (24 m²/h) with the 60-in printer, 220 ft²/h (21 m²/h) with the 42-in printer.
- Environmentally friendly, odorless, aqueous latex inks in six colors
- No special ventilation required, no hazardous waste
- 775 ml ink cartridges
- Print on a wide range of substrates—including most low-cost, uncoated, solvent-compatible substrates
- A range of HP recyclable substrates is available
- Durable prints with outdoor display permanence up to three years un laminated, five years laminated

- Accurate and consistent color reproduction with automatic color calibration (built-in spectrophotometer)
- ENERGY STAR® qualified product

To send print jobs to your printer, you will need Raster Image Processor (RIP) software, which should be run on a separate computer. RIP software is available from various different companies; it is not provided with the printer.

The printer's main components

The following views of the printer illustrate its main components.

Front view 60-in printer

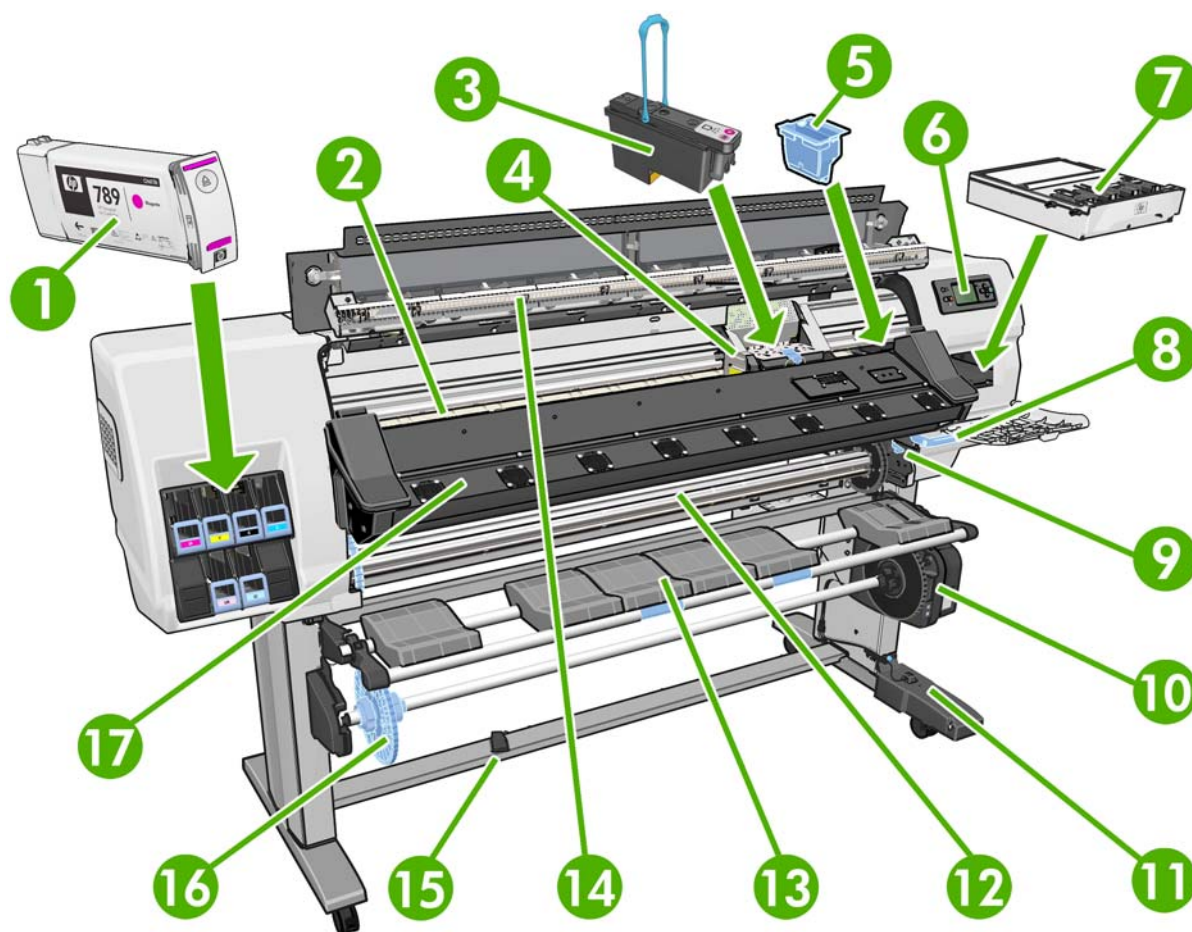

1. Ink cartridge
2. Platen
3. Printhead
4. Printhead carriage
5. Ink funnel
6. Front panel
7. Printhead cleaning cartridge
8. Substrate-adjustment lever

9. Spindle lock lever
10. Take-up reel motor
11. Take-up reel cable and sensor housing unit
12. Spindle
13. Loading table
14. Drying module
15. Take-up reel sensor
16. Take-up reel spindle stop
17. Curing module

Rear view 60-in printer

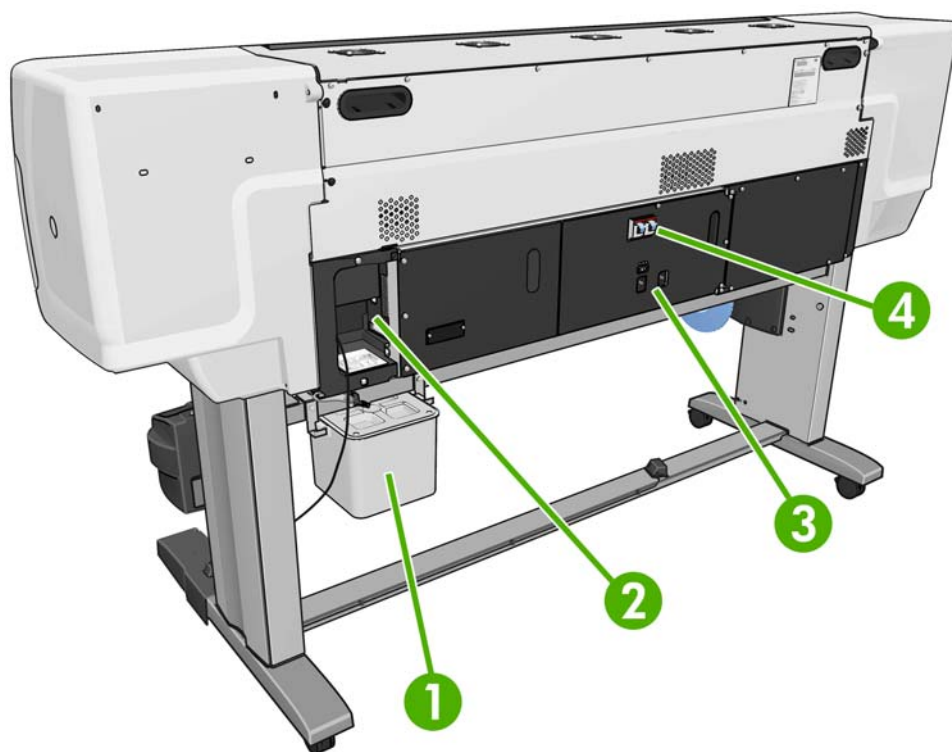

1. Printhead cleaning container
2. Sockets for communication cables and optional accessories
3. Power switch and power sockets
4. Residual current circuit breakers for the heating components

Take-up reel motor

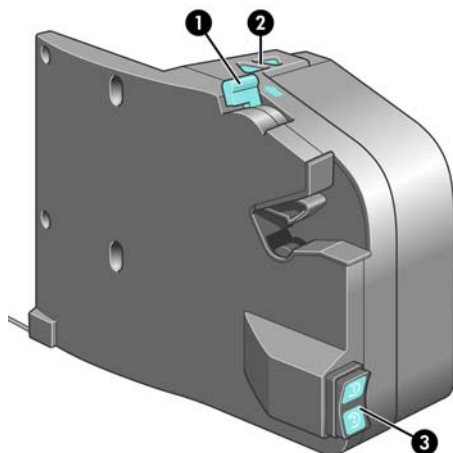

1. Take-up reel spindle lever
2. Manual winding buttons
3. Wind-direction switch

The front panel

Your printer's front panel is located at the front right of the printer. It has the following important functions:

- Assists you in troubleshooting issues
- Is used when performing certain physical operations, such as unloading substrate and maintaining the printer
- Displays information in brief about the status of the printer
- Displays warning and error messages, when appropriate, along with audio alerts to call attention to a warning or message

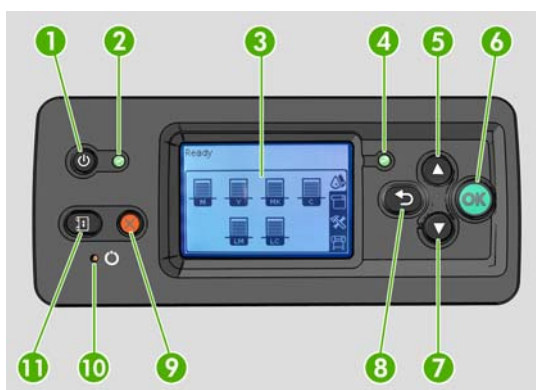

The front panel has the following components:

1. **Power key:** To turn the printer off. See [Turn the printer on and off on page 11](#).
2. **Power light:** Indicates the printer's power status. If the light is off, the printer is off. If it is solid green, the printer is on. If it is flashing green, the printer is in transition between on and off.
3. **Front-panel display:** Displays error, warnings and information on using your printer.
4. **Status light:** Indicates the printer's operational status. If the light is off, the printer is not ready. If it is solid green, the printer is ready and idle. If it is flashing green, the printer is busy: receiving data,

processing or printing. If it is flashing amber, your intervention is required. If it is solid amber, a serious error has occurred.

5. **Up** key: To go up in a menu or option, or to increase a value.
6. **OK** key: To confirm an action while in a procedure or interaction. To enter in a submenu in the menu. To select a value when given an option.
7. **Down** key: To go down in a menu or option, or to decrease a value.
8. **Back** key: To go to the previous step in a procedure or interaction. To go to the upper level, or leave the option in the menu, or when given an option.
9. **Cancel** key: To cancel a procedure or interaction.
10. **Reset** key: To restart the printer (as if it were switched off and switched on again). You will need an implement with a narrow tip to operate this key.
11. **Move substrate** key: To move the loaded substrate forwards or backwards. While the printer is printing, it can be used to fine-tune the substrate advance on the fly.

To **highlight** an item in the front-panel display, press the **Up** or **Down** key until the item is highlighted.

To **select** an item in the front-panel display, first highlight it and then press the **OK** key.

When this guide shows a series of front-panel display items like this: **Item1 > Item2 > Item3**, it means that you should select **Item1**, then select **Item2**, then select **Item3**.

Information about specific uses of the front panel can be found throughout this guide.

The Embedded Web Server

The Embedded Web Server is a Web server running inside the printer. You can use it to obtain printer information, manage settings and presets, align printheads, upload new firmware and troubleshoot problems. Service engineers can use it to retrieve internal information that helps to diagnose printer problems.

You can access the Embedded Web Server remotely by using an ordinary Web browser running on any computer. See [Access the Embedded Web Server on page 13](#).

The Embedded Web Server window displays three separate tabs. Buttons near the top of each page provide access to online help and supplies reordering.

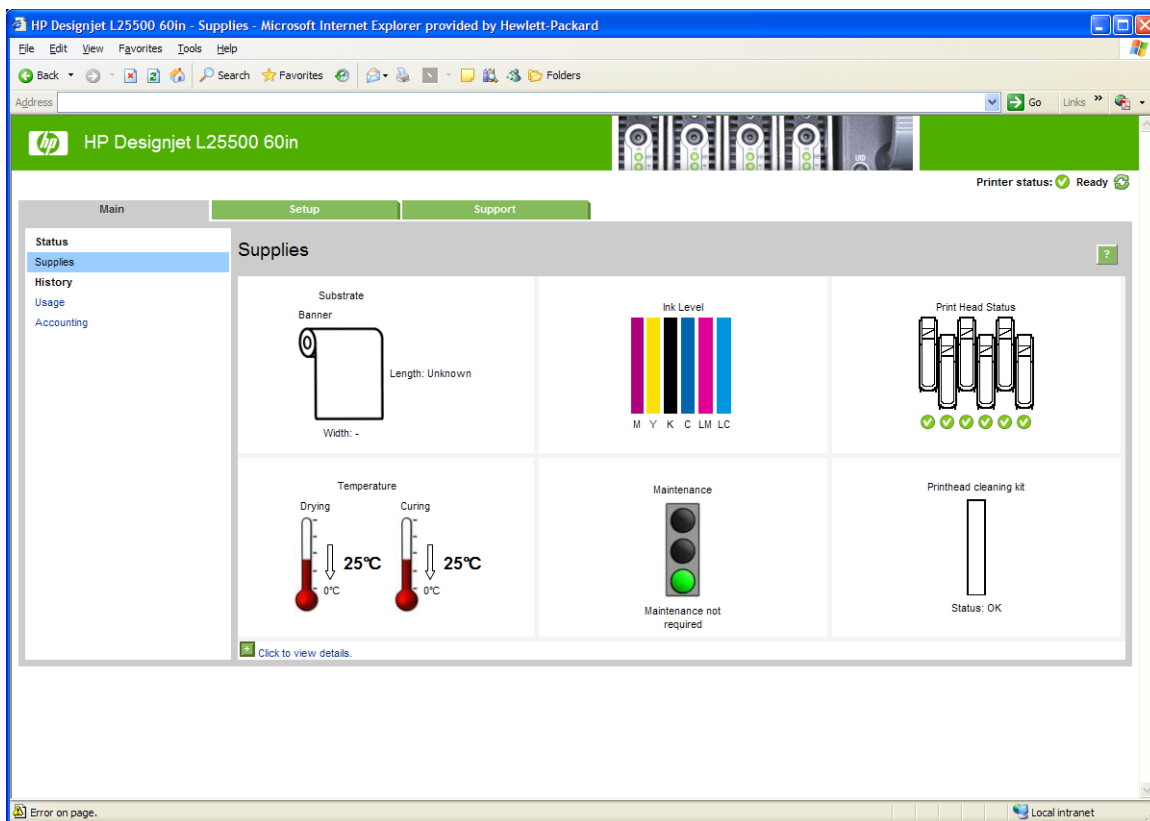

Main tab

The **Main** tab provides information about the following items:

- Substrate, ink, printhead and maintenance status
- Temperatures of the drying and curing modules
- Substrate and ink usage and accounting

Setup tab

The **Setup** tab includes options to complete these tasks:

- Specify printer settings such as units of measurement and refresh date
- Specify network and security settings
- Set the date and time
- Update firmware
- Align printheads
- Upload substrate presets

Support tab

The **Support** tab contains options to complete these functions:

- Browse helpful information from a variety of sources
- Access HP Designjet links for technical support with your printer and accessories
- Access service support pages that show current and historical data on the usage of your printer

2 Connectivity and software instructions

Connection method

Your printer can be connected in the following way.

Connection type	Speed	Maximum cable length	Other factors
Gigabit Ethernet	Fast; varies according to network traffic	Long (100 m=328 ft)	Requires extra equipment (switches)

 **NOTE:** The speed of any network connection depends on all the components that are used in the network, which can include network interface cards, hubs, routers, switches, and cables. If any one of these components cannot operate at high speed, you will have a low-speed connection. The speed of your network connection can also be affected by the total amount of traffic from other devices on the network.

Connect to a network

Before you begin, check your equipment:

- The printer should be set up and turned on.
- The Gigabit switch or router should be on and functioning correctly.
- All computers on the network should be turned on and connected to the network.
- The printer should be connected to the switch.

When the printer is connected to the network and turned on, you should see the printer's IP address appear on the front panel (192.168.1.1 in this example). Make a note of the IP address: you can use it later to access the Embedded Web Server.

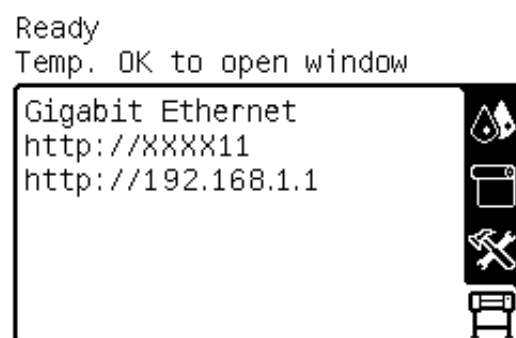

If you see this screen without the IP address, either the printer is not successfully connected to the network, or your network has no DHCP server. In the latter case, you will have to set the IP address manually: see the *Maintenance and troubleshooting guide*.

Refer to the RIP instructions (not provided by HP) to install the software RIP.

3 Basic setup options

Printer setup options

Turn the printer on and off

To turn on the printer, ensure that the power switch at the rear of the printer is turned on, ensure that the residual current circuit breakers are in the up position, then press the **Power** button on the front panel. You can leave the printer on without wasting energy. Leaving it on improves response time. When the printer has not been used for a certain period of time, it saves power by going into sleep mode. Any interaction with the printer returns it to active mode, and it can resume printing immediately.

If you want to turn the printer on or off, the normal and recommended method is to use the **Power** button on the front panel.



When you turn off the printer this way, the printheads are automatically stored with the printhead cleaning cartridge, which prevents them from drying out.

However, if you plan to leave the printer turned off for a long period of time, you are recommended to turn it off using the **Power** button, and then also turn off the power switch at the rear.

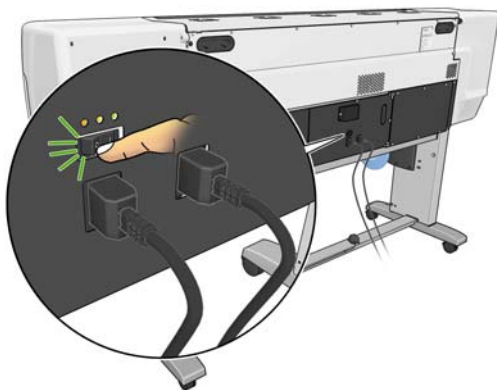

To turn it back on later, use the power switch at the rear, and then press the **Power** button.

When the printer is turned on, it will take about ten minutes to initialize itself.

Restart the printer

In some circumstances you may be advised to restart the printer. Please proceed as follows:

1. Press the **Power** button on the front panel to turn the printer off. Wait a few moments, and then press the **Power** button again. This should restart the printer. If it does not, continue with step 2.
2. Use the **Reset** button on the front panel. You will need a non-conductive implement with a narrow tip to press the **Reset** button. This normally has the same effect as pressing the **Power** button, but may work if the **Power** button does not.
3. If neither steps 1 nor 2 seems to have any effect, turn off the printer by using the power switch at the rear of the printer. Check that the residual current circuit breakers are in the up position.
4. Remove the power cords from the power sockets.
5. Wait for 10 seconds.
6. Reinsert the power cords into the power sockets and turn on the printer by using the power switch.
7. Make sure that the **Power** light on the front panel illuminates. If it does not, use the **Power** button to turn on the printer.

Change the language of the front panel

Two methods are available to change the language that is used for the front-panel menus and messages.

- If you can understand the current front panel language, go to the front panel and select the  icon, and then select **Front panel options > Select language**.
- If you cannot understand the current front panel language, start with the printer powered off. At the front panel, press the **OK** button and hold it down. While holding down the **OK** button, press the **Power** button and hold it down. Continue to hold down both buttons until the green light on the left side of the front panel starts flashing, and then release both buttons. You can expect a delay of about one second. If the green light starts flashing without any delay, you may need to start again.

Whichever method you used, the language selection menu should now appear on the front panel.

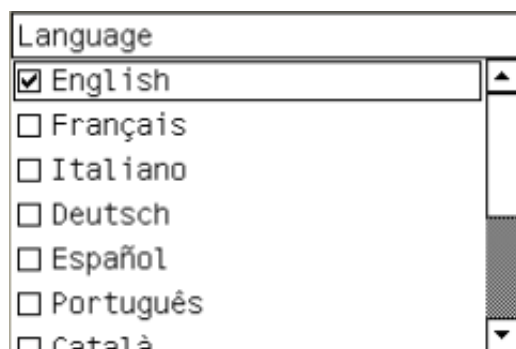

Highlight your preferred language, and then press the **OK** button.

Request e-mail notification of specific error conditions

1. In the Embedded Web Server, go to the E-mail server page on the **Setup** tab and ensure that the following fields are correctly filled in:
 - **SMTP server.** This is the IP address of the outgoing mail server (Simple Mail Transfer Protocol [SMTP]) that processes all e-mail messages from the printer. If the mail server requires authentication, e-mail notifications will not work.
 - **Printer e-mail address.** Each e-mail message that the printer sends must include a return address. This address does not need to be a real, functional e-mail address, but it should be unique, so that recipients of the message can identify the printer that sent it
2. Go to the Notification page, which is also on the **Setup** tab.
3. Click the **New** icon to request new notifications, or click the **Edit** icon to edit notifications that have already been set up. Then specify the e-mail addresses to which notifications are sent, and select the incidents that result in notification messages.

Change the sleep mode setting

If the printer is left turned on but unused for a certain period of time, it automatically goes into sleep mode to save power. The default period of time it waits is 30 minutes. To change the time the printer waits before it goes into sleep mode, go to the front panel and select the  icon, and then select **Front panel options** > **Sleep mode wait time**. Highlight the wait time that you want, and then press the **OK** button.

Change the front panel display contrast

To change the contrast of the front-panel display, select the  icon, select **Front panel options** > **Select display contrast**, and then select a value by using the **Up** or **Down** button. Press the **OK** button to save the value.

Change the units of measurement

To change the units of measurement that appear on the front panel, select the  icon, select **Front panel options** > **Select units**, and then select **English** or **Metric**.

The units of measurement can also be changed in the Embedded Web Server.

Embedded Web Server setup options

Access the Embedded Web Server

Use the Embedded Web Server to view printer information remotely through an ordinary Web browser running on any computer.

The following browsers are known to be compatible with the Embedded Web Server:

- Internet Explorer 6 to 8 for Windows
- Mozilla Firefox 2 to 3.5

To use the Embedded Web Server on any computer, open your Web browser and type the printer's URL. The printer's URL appears on the status screen on the printer's front panel (<http://192.168.1.1> in this example):

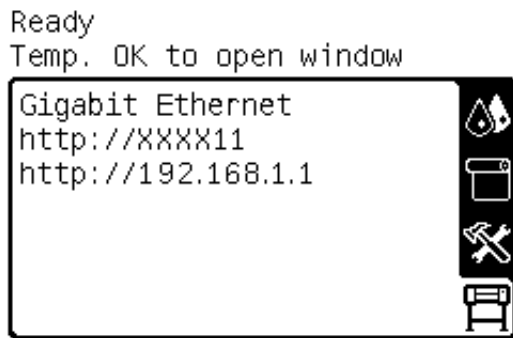

If you follow these instructions but fail to open the Embedded Web Server, see the *Maintenance and troubleshooting guide*.

Change the language of the Embedded Web Server

The Embedded Web Server functions in the following languages: English, Portuguese, Spanish, Catalan, French, Italian, German, Simplified Chinese, Traditional Chinese, Korean, and Japanese. It uses the language that you specified in your Web browser options. If you specify a language that it cannot support, it functions in English.

To change the language, change your Web browser's language setting. For example, in Internet Explorer version 6, go to the **Tools** menu and select **Internet Options > Languages**. Make sure that the language you want is at the top of the list in the dialog box.

To complete the change, close and reopen your Web browser.

4 Handle the substrate

Overview

You can print on a wide variety of printing materials, all of which are referred to in this guide as substrates.

Use substrate

Choosing the correct substrate for your needs is an essential step in ensuring good print quality. For best printing results, use only recommended HP substrates (see [Supported substrate families on page 16](#)), which have been developed and thoroughly tested to ensure reliable performance. All printing components (printer, ink system, and substrate) have been designed to work together to offer trouble-free operation and ensure optimal print quality.

Here are some additional tips about substrate usage:

- Allow all substrates to adapt to room conditions, out of the packaging, for 24 hours before using them for printing.
- Handle film and photo substrates by the edges, or wear cotton gloves. Skin oils can be transferred to the substrate, leaving fingerprint marks.
- Keep the substrate tightly wound on the roll throughout the loading and unloading procedures. To make sure that the roll stays tightly wound, consider using tape to stick the leading edge of the roll to the core just before removing the roll from the printer. You can keep the roll taped during storage. If the roll starts to unwind, it can become difficult to handle.

 **NOTE:** The use of tape to stick the leading edge of the roll to the core is especially important for heavy substrates, because the inherent stiffness of the substrate can cause it to loosen and unwind from the core.

- Whenever you load a roll, the front panel prompts you to specify the substrate family that you are loading. For good print quality, it is essential to specify this correctly. Check that the substrate belongs to the family named on the front panel, and check also that it matches the substrate profile in the RIP.
- Print quality could be impaired if you use a substrate that is unsuitable for your image.
- Make sure that the appropriate print-quality setting is selected in the RIP.
- If the substrate family shown on the front panel does not correspond to the substrate that you intend to use, take one of the following actions:
 - Reload the roll into the printer and select the correct substrate family. See [Unload a roll from the printer on page 22](#) and [Load a roll into the printer on page 19](#).
 - At the printer's front panel, select the  icon, and then select **View loaded substrate > Change loaded substrate**.

 **NOTE:** Substrate advance calibration is not performed when the substrate family is changed from the front panel.

△ **CAUTION:** Removing the substrate from the printer manually without using the front panel could damage the printer. Do this only when necessary to clear a substrate jam.

Supported substrate families

Substrate family	Substrate types
Self-adhesive	Self-adhesive vinyls (cast and calendered), perforated vinyls
Banner	Banners
Film	Polyester films
Fabric	Fabrics and canvas
Mesh	Mesh materials
Paper-Aqueous	Papers compatible with water-based inks (otherwise known as offset)
Paper-Solvent	Papers compatible with solvent-based inks, cellulose coating (otherwise known as billboard)
HP Photorealistic	HP Photorealistic Poster Paper

Load a roll onto the spindle

1. Make sure that the printer wheels are locked (the brake lever is pressed down) to prevent the printer from moving.
2. Lift the spindle lock lever to disengage the spindle.

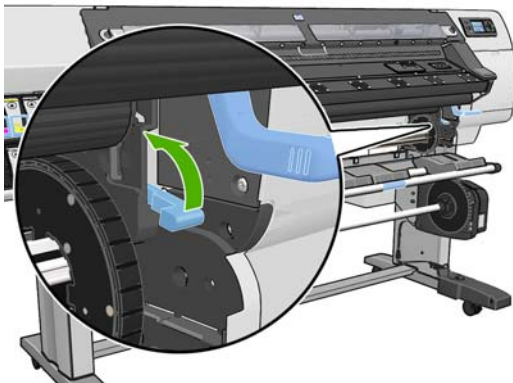

Handle the substrate

3. Remove the first end of the spindle from the right side of the printer, and then move the spindle to the right in order to extract the other end. Do not insert your fingers into the spindle supports during the removal process.

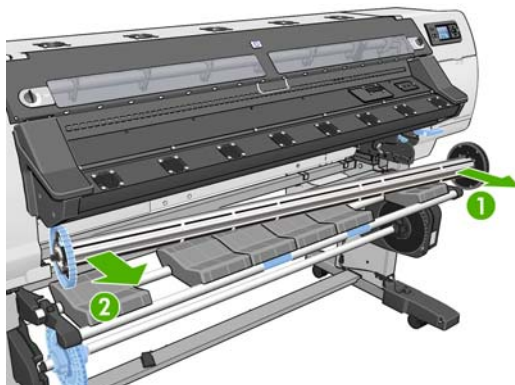

The spindle has a stop at each end to keep the roll in position. Remove the blue stop at the left end to mount a new roll (the stop at the other end can also be removed, if you wish). The stop slides along the spindle to hold rolls of different widths.

4. Slide the lever-lock on the blue stop to the unlocked position.

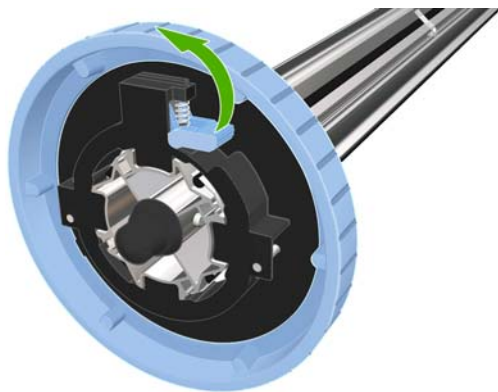

5. Remove the stop from the left end of the spindle.



6. Rest the roll of substrate that you want to load on the loading table. If the roll is long and heavy, you may need two people to handle it.

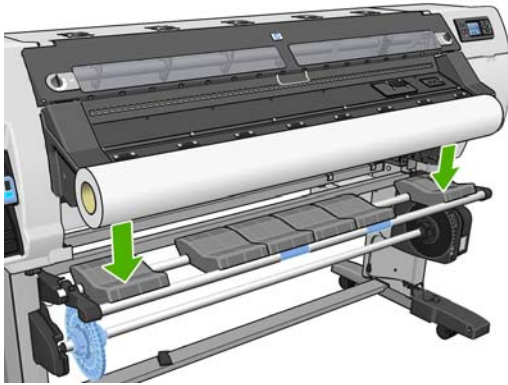

7. Slide the spindle into the roll.

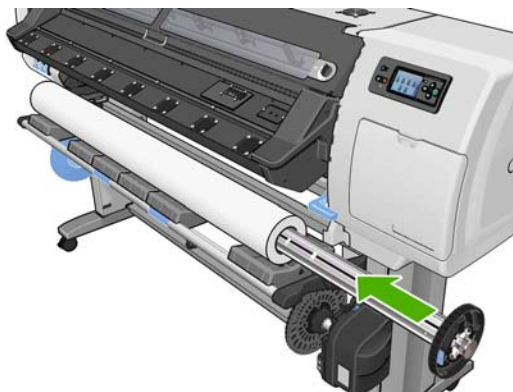

8. The right stop of the spindle has two positions: one for rolls of the printer's maximum width, and another for narrower rolls.

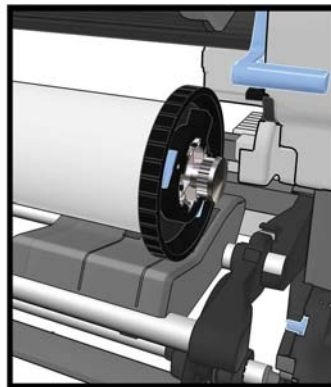
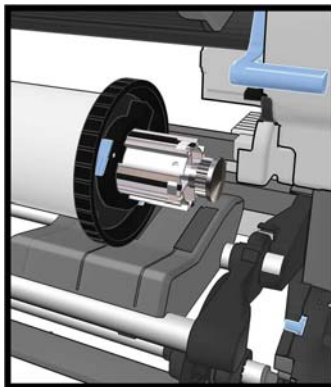

9. Put the blue stop on to the upper end of the spindle, and push it towards the end of the roll.

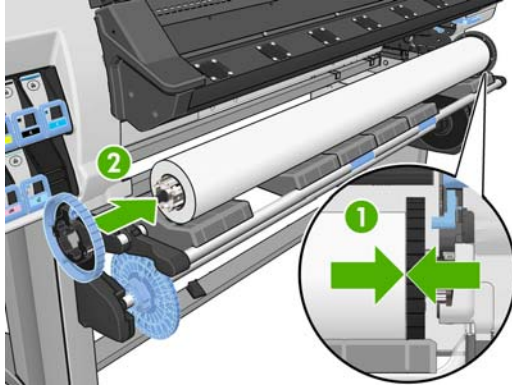

10. Slide the lever-lock to the locked position.

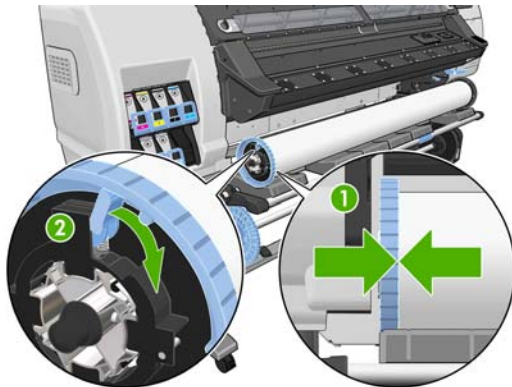

11. Lift the loading table to ease the spindle into the printer.

△ **CAUTION:** To avoid trapping your fingers, do not push the roll with your hands.



If you regularly use different substrates, you can change rolls more quickly if you pre-load rolls of different substrates on different spindles. Extra spindles are available for purchase.

Load a roll into the printer

To start this procedure, you need to have a roll loaded on the spindle. See [Load a roll onto the spindle on page 16](#).

The normal minimum substrate width is 23 inches (584 mm). To load substrates down to a minimum width of 10 inches (254 mm), go to the front panel and select the  icon, then select **Substrate handling options > Enable narrow substrate**. With this option, print quality is not guaranteed.

TIP: To load a roll of textile material, cut a strip of another substrate of a similar width to the textile and around 0.5 m in length. Polyester (backlit) substrates are the best for this purpose because of their stiffness. Lay this strip of substrate on top of the leading edge of the textile and load the two together as described below. After loading, the substrate strip will probably fall on the floor on the far side of the printer; if not, remove it.

1. At the printer's front panel, select the  icon, and then select **Substrate load > Load roll**.

Substrate load

- ▶ Load roll
- ▶ Learn how to load spindle

Alternatively, feed paper into the printer until the printer grasps it. The front panel will guide you through the following steps.

2. Carefully insert the leading edge of the substrate above the black-ribbed roller, making sure the substrate remains taut during the process. Avoid pulling excess substrate from the roll, which could cause skew. Also avoid rewinding the substrate manually, unless the printer asks you to do so.

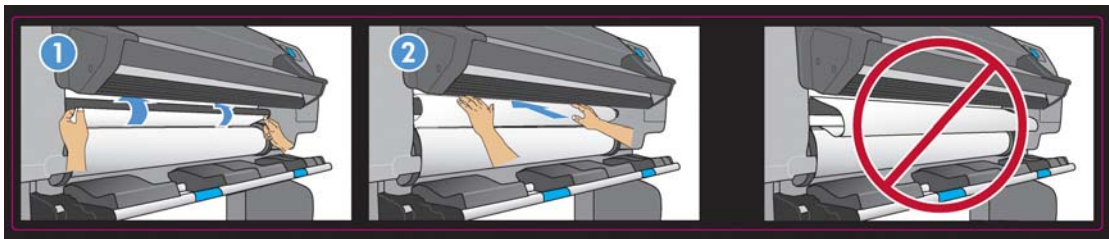

WARNING! Take care not to touch the rubber wheels on the platen while loading substrate. These wheels can rotate and trap skin, hair or clothing.

WARNING! Take care not to push your fingers inside the printer's substrate path.

The printer beeps when it detects and accepts the leading edge of the substrate.

3. Select the substrate category of the roll you are loading.

Select substrate category

- Self-Adhesive
- Banner
- Film
- Fabric
- Mesh
- Paper-Aqueous
- Paper-Solvent

NOTE: You should select the name of the particular substrate that you are using in your RIP software, not in the front panel.

TIP: When loading very thin or very thick substrates, you should follow a special procedure to reduce the risk of substrate jams and printhead crashes. When loading very thin substrates, always give the substrate category as **Banner** to minimize the vacuum pressure applied while loading; when loading very thick substrates, always give the substrate category as **HP Photorealistic** to maximize the vacuum pressure. After loading and before printing, go to the front panel and change to the correct category for the substrate you are loading: select the  icon, then select **View loaded substrate > Change loaded substrate**.

4. The printer checks the substrate in various ways and may ask you to correct problems with skew or tension.

 **NOTE:** You can specify the maximum permitted amount of skew at the front panel: select the  icon, then select **Substrate handling options > Max skew setting**.

5. Wait until the substrate emerges from the printer, as shown in the following graphic.

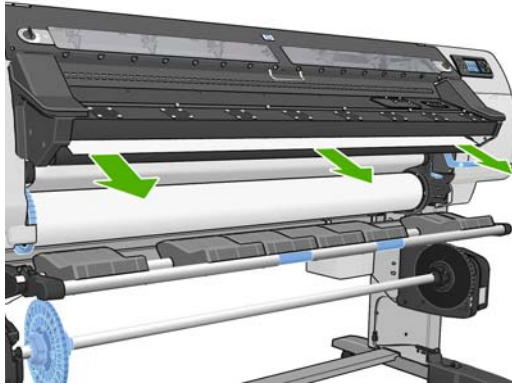

 **NOTE:** If you have an unexpected problem at any stage of the substrate loading process, see the *Maintenance and troubleshooting guide*.

6. The printer calibrates the substrate advance.
7. If you are loading transparent substrate without opaque borders, you are asked to enter the width of the substrate and the distance of the right edge from the printer's side plate (as indicated by the ruler on the front of the curing module).
8. The printer indicates that it is ready for printing.

Ready

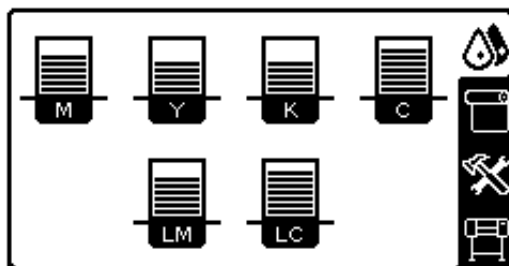

Take care not to cover the fans.

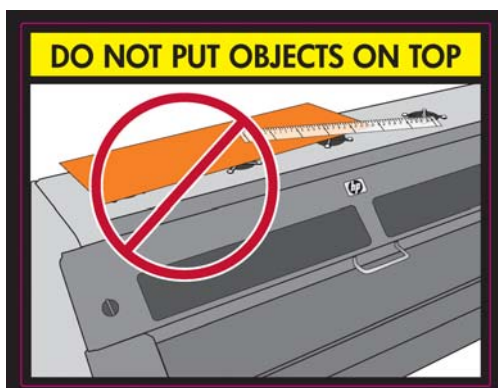

If you have the take-up reel and want to use it, see [Use the take-up reel on page 23](#).

Unload a roll from the printer

If you used the take-up reel during printing, unload the printed roll from the take-up reel before attempting to remove the roll from the printer. See [Unload a roll from the take-up reel on page 29](#).

Check whether the other end of the roll is still attached to the input spindle, and follow the appropriate procedure as described in the following sections.

The normal procedure (roll attached to spindle)

If the end of the roll is still attached to the spindle, use the following procedure.

1. On the printer's front panel, select the  icon, and then select **Substrate unload > Unload roll**.
2. Press the **OK** button on the front panel as many times as needed to rewind the substrate.
3. Lift the spindle lock lever.
4. Remove the roll from the printer, pulling out the right end on the right side of the printer first. Do not insert your fingers into the spindle supports during the removal process.

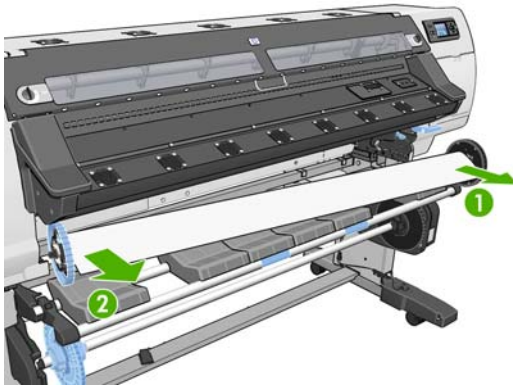

Exceptional procedure (roll detached from spindle)

Use the following procedure if the end of the roll is visible but no longer attached to the spindle:

1. If you have already selected **Substrate unload** at the front panel, press the **Cancel** button to cancel that procedure.
2. Lift the substrate-adjustment lever. If the front panel shows a warning about the lever, ignore it.

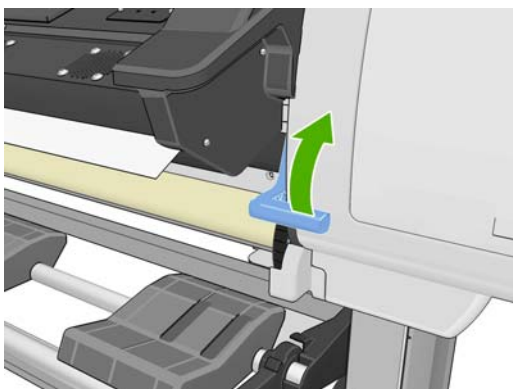

3. Pull out the substrate from the front of the printer.

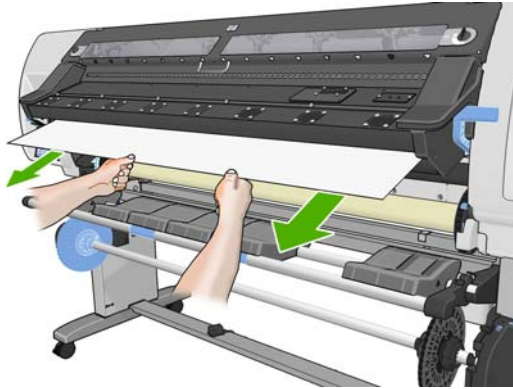

4. Remove the empty spindle from the printer, pulling out the end on the right side of the printer first. Do not insert your fingers into the spindle supports during the removal process.
5. Lower the substrate-adjustment lever.
6. If the front panel shows a warning message, press the **OK** button to clear it.

 **NOTE:** If the end of the roll has disappeared inside the printer, use the **Move substrate** button on the front panel to move it forward.

Use the take-up reel

The take-up reel must be enabled and operated from the front panel. When the take-up reel is enabled, the “Take-up reel enabled” message appears on the **Substrate** tab on the front panel. If the take-up reel is not enabled and you would like to enable it, select the  icon and then select **Take-up reel > Enable take-up reel**.

Follow these guidelines when taping rolls to the take-up reel spindle core:

- Make sure that the substrate is straight when it is attached to the spindle core. Otherwise it skews as it winds onto the core.
- The spindle core on the take-up reel must be the same width as the substrate that you are using.
- Check that neither side of the spindle core has end caps, and make sure the spindle core is pushed firmly into both spindle guides.

 **NOTE:** If you want to load the take-up reel during printing, familiarize yourself with the procedural steps. Loading the take-up reel during printing requires you to complete the procedure while the printer is feeding and printing substrate. Loading the take-up reel during printing saves approximately 1 m (3 feet) of substrate.

Load a roll onto the take-up reel

1. On the printer's front panel, select the  icon, and then select **Substrate load > Load take-up reel**.

2. If you want to load the take-up reel now, select **Load take-up reel now** on the front panel. If you want to load the take-up reel during printing, select **Load it during printing** on the front panel.

Would you like to load paper onto take-up reel now or save paper and load it later during printing?

Load take-up reel now

Load it during printing

3. Make sure that the loading table is in its upright position.

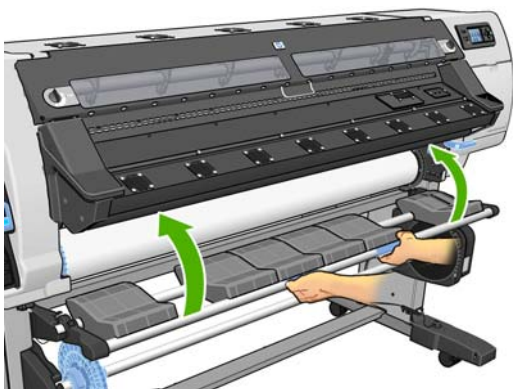

4. Unlock the take-up reel spindle by pushing the spindle lever to its uppermost position.

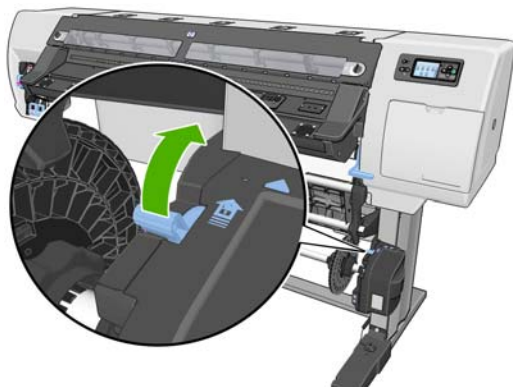

5. Remove the take-up reel spindle.

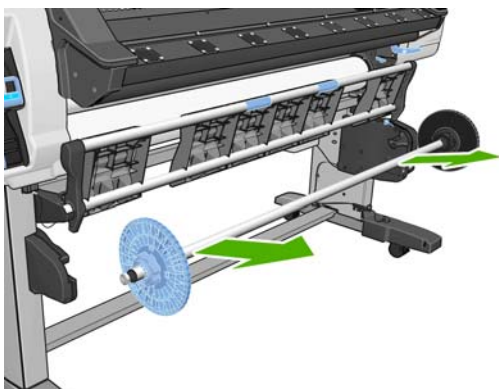

6. Remove the blue stop from the spindle.

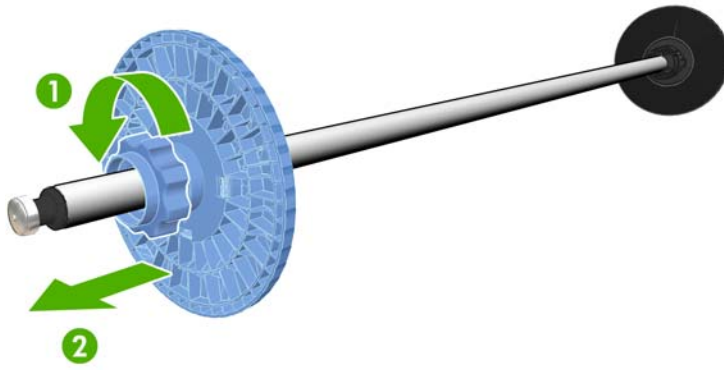

7. Load the core onto the take-up reel spindle.

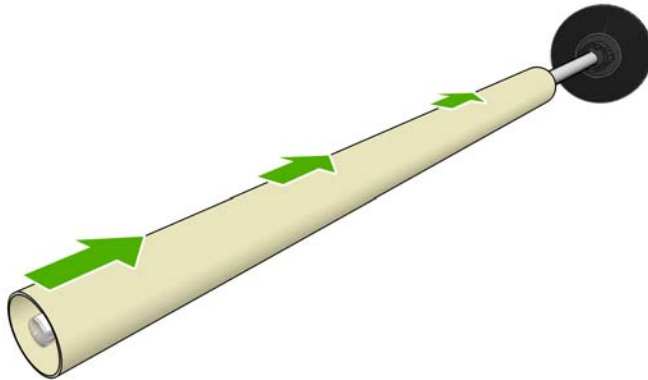

8. Replace the blue stop on the spindle.

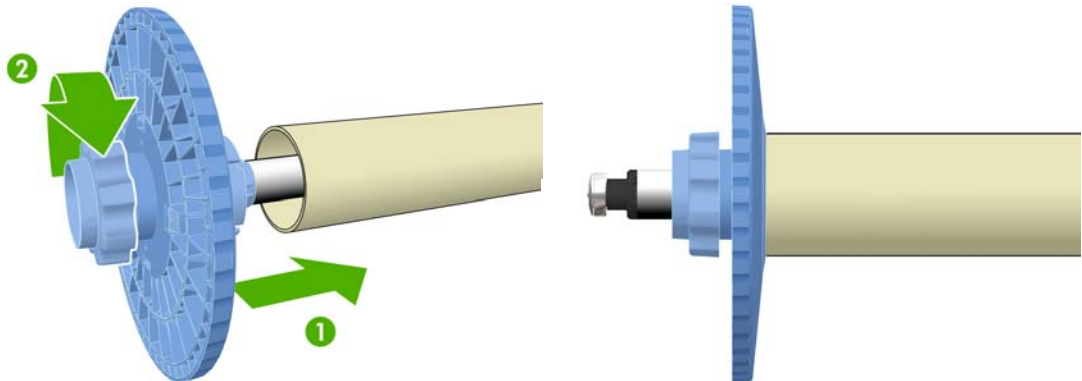

9. Load the take-up reel spindle into the printer by pushing firmly on both ends of the spindle.

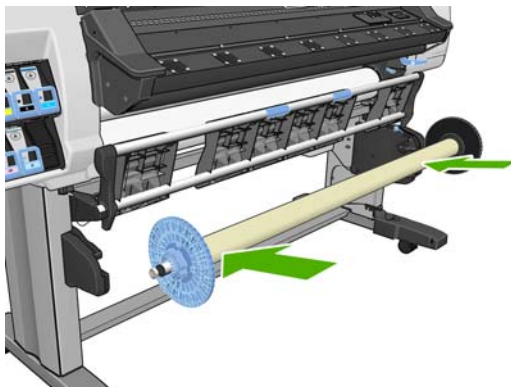

Handle the substrate

10. Press the OK button on the front panel, and then select a winding direction.

Select the printed roll winding direction
<input type="checkbox"/> Printed face outwards
<input type="checkbox"/> Printed face inwards

The printer advances the substrate. Make sure that the substrate passes in front of the loading table, as shown.

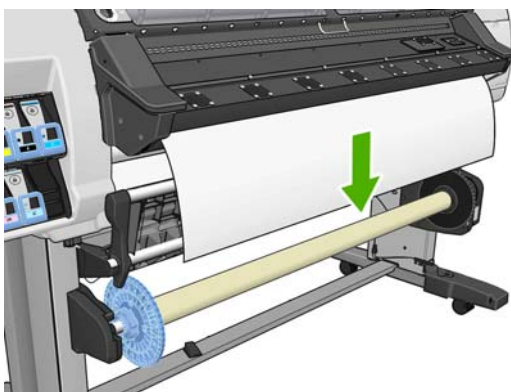

11. Pull the substrate taut to the position shown in the following figure. Do *not* attempt to pull more substrate out of the printer. Use tape to secure the substrate to the spindle core, taping it in the center first. You may need to use more tape than is shown in the following image. The substrate should be secure enough to support the weight of the loop-shaping core, which you insert in step 12.

 **NOTE:** If you are loading the take-up reel **during** printing you do not need to pull the substrate taut. Tape the substrate to the spindle core when an adequate length of substrate has fed from the printer after printing begins.

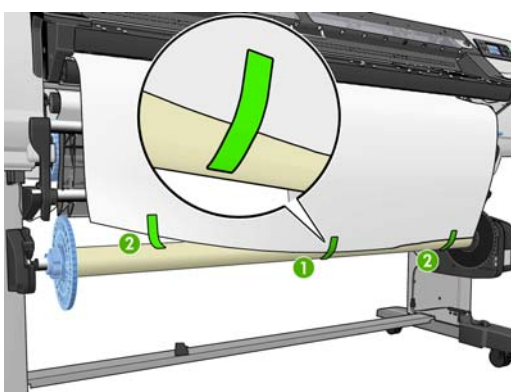

 **NOTE:** To avoid having the substrate skew as it winds onto the spindle core, make sure the substrate is straight when you attach it, and aligned with the input roll. It is sometimes useful to use the core grooves to align the substrate.

12. Press the **OK** button on the front panel. The printer advances the substrate.

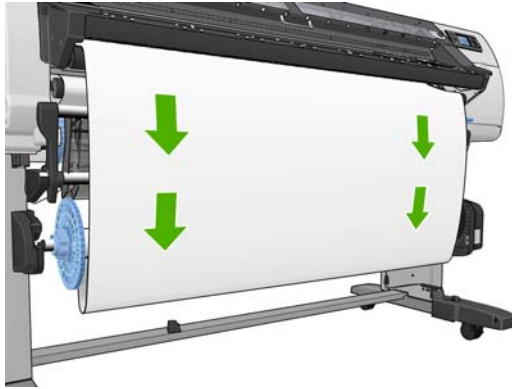

13. Assemble a loop-shaping core by matching the shape-coded and color-coded lengths of plastic tubing. The loop-shaping core must be the same width as the substrate that you are using. Make sure that both end caps are firmly fitted on the ends of the loop-shaping core.

 **NOTE:** The front-panel display shows the required length of the loop-shaping core based on the width of the roll that you have loaded into the printer.

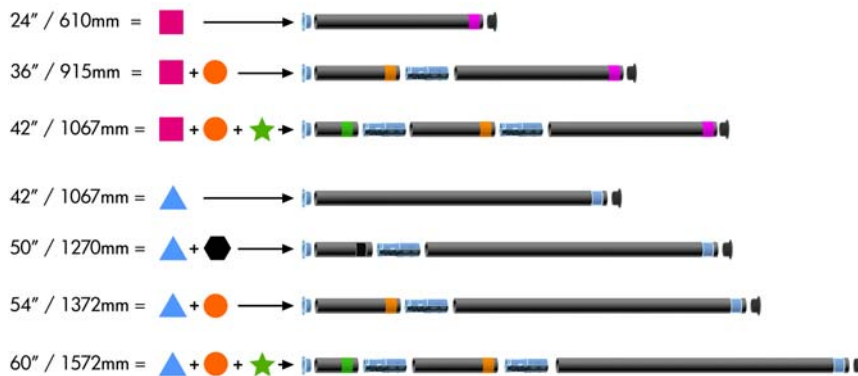

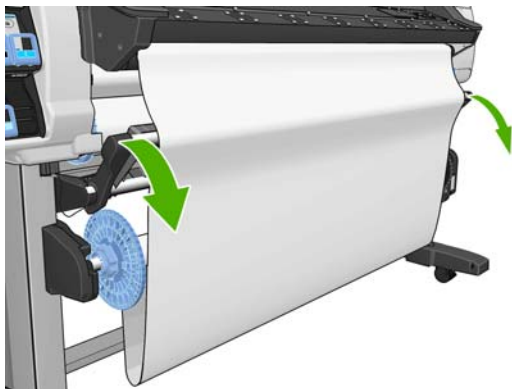

14. Gently lower the loading table, to avoid wrinkles and improve winding.

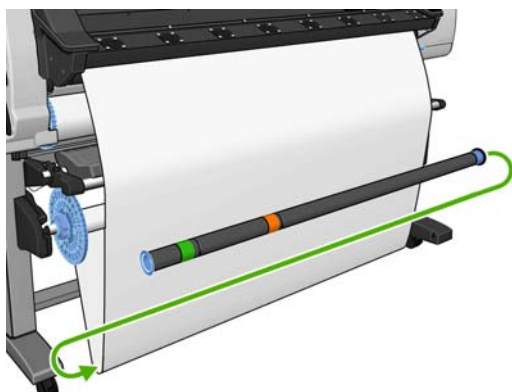

Handle the substrate

15. Carefully insert the loop-shaping core.



 **NOTE:** Make sure that you insert the loop-shaping core. The take-up reel will not function correctly without it. The loop-shaping core must have end caps. Make sure that the end caps extend over the edges of the substrate.

16. Use the wind-direction switch on the take-up reel motor to select the winding direction. Setting 1 winds the substrate so that the printed image faces in. Setting 2 winds the substrate so that the printed image faces out.

The front panel shows you the correct setting based on the winding-direction decision you made in step 7.

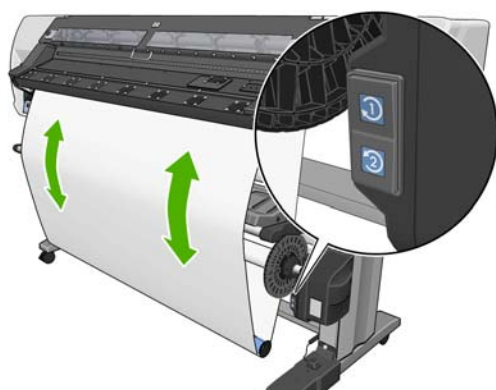

17. Press the **OK** button on the front panel. The **Take-up reel has been successfully installed** message appears.
18. The following image shows how the printer looks when it is operating. As substrate is fed from the printer, it drops down in a loop and then up into the take-up reel spindle.

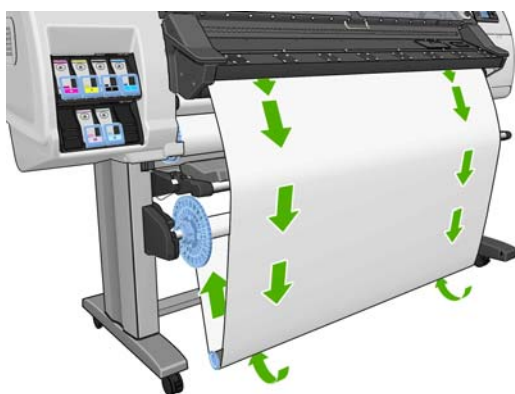

 **NOTE:** While the take-up reel is operating, make sure that the take-up reel sensors are not blocked.

NOTE: The cutter is disabled when the take-up reel is in use.

NOTE: If you want to move the printer, first remove the take-up reel sensor and cable housing unit from the foot of the printer stand. Place the sensor and cable housing unit on the printer stand crossbar and use the blue plastic screw to affix the housing unit to the leg of the stand, as shown, while the printer is being moved. When reinstalling the housing unit, make sure that the wheel on the foot of the printer stand is pointing forward.

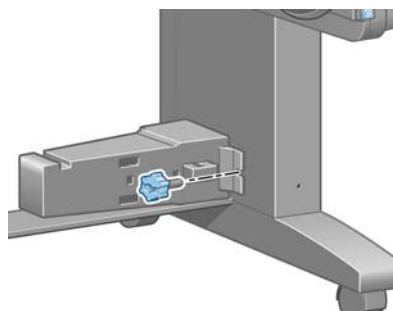

Unload a roll from the take-up reel

1. On the printer's front panel, select the  icon, and then select **Substrate unload > Unload roll**.
The printer advances the substrate to allow for cutting.

2. Lift the loading table to its upright position.



3. Switch the wind-direction switch to the Off position. The switch is in the off position when it is centered (in other words, when the switch is neither in position 1 nor position 2).

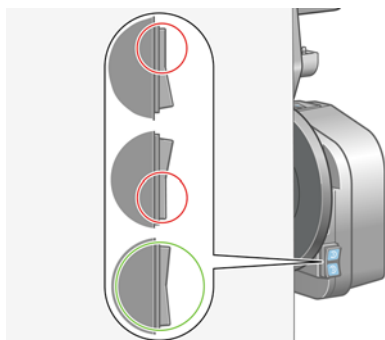

4. Remove the loop-shaping core.

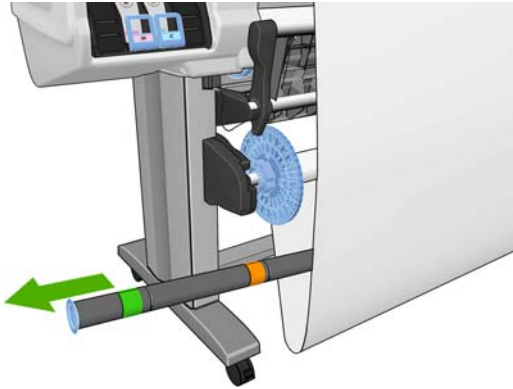

5. Use the winding button on the take-up reel motor to wind the excess substrate around the take-up reel spindle.

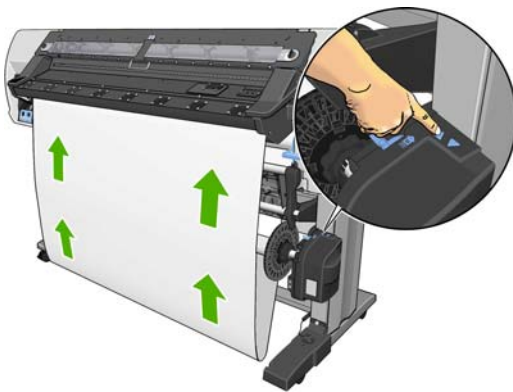

6. Press the OK button on the front panel.

7. Use the winding button on the take-up reel motor to wind the remainder of the substrate around the take-up reel spindle.

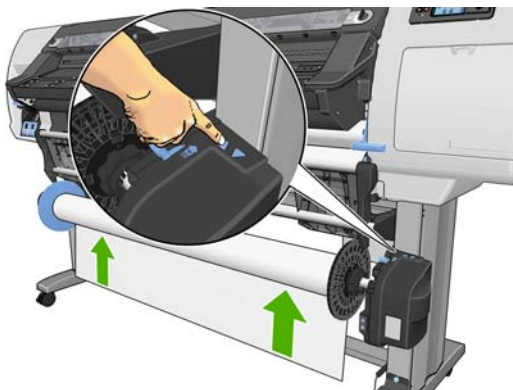

8. Press the OK button on the front panel.

The amount of printed substrate that is on the take-up reel spindle appears on the front panel.

9. Unlock the take-up reel spindle by pushing the spindle lever to its uppermost position.

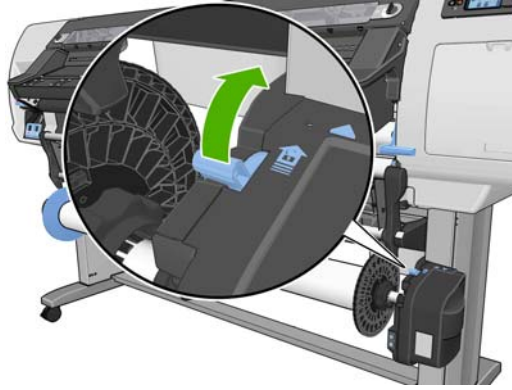

10. Remove the roll from the printer, pulling out the end on the right side of the printer first. Do not insert your fingers into the spindle supports during the removal process.

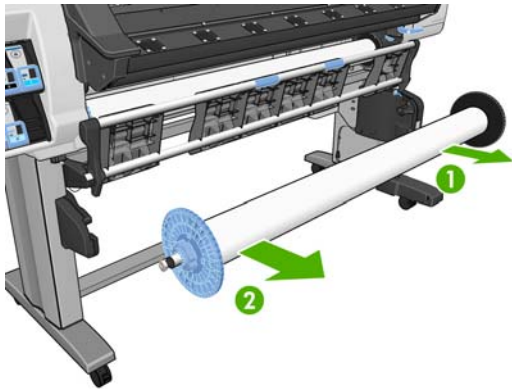

11. To remove the roll from the printer after you have unloaded the take-up reel, see [Unload a roll from the printer on page 22](#).

View information about the substrate

On the printer's front panel, select the  icon, and then select **View loaded substrate > View substrate details**.

The following information appears on the front panel:

- The roll status
- The substrate family that you have selected
- The width of the substrate in millimeters (estimated by the printer)

If no substrate is loaded, the message **Out of substrate** appears.

The same information appears on the Embedded Web Server's Supplies page.

Store the substrate

The following are tips for storing substrate:

- Always keep unused rolls wrapped in the plastic wrap to prevent discoloration. Rewrap partially used rolls if they are not being used.
- Do not stack rolls.

- Allow all substrates to adapt to room conditions out of the packaging for 24 hours before printing.
- Handle film and glossy substrates by the edges or wear cotton gloves. Skin oils can be transferred to the substrate, leaving fingerprint marks.
- Keep the substrate tightly wound on the roll throughout the loading and unloading procedures. If the roll starts to unwind, it can become difficult to handle.

Download substrate presets

Each supported substrate type has its own characteristics. The printer changes the way it prints on each different substrate type. The RIP requires a description of the requirements of each substrate type. This description is called the “substrate preset”.

The substrate preset contains the ICC profile, which describes the color characteristics of the substrate. It also contains information about other characteristics and requirements of the substrate that are not directly related to color. Substrate presets for your printer are installed in the RIP.

The RIP contains substrate presets for only the most commonly used substrate types. If you buy a substrate type for which your RIP has no preset, you can obtain a preset for a new substrate type in the following ways:

- Try to download the substrate preset from the substrate manufacturer's Web site.
- If it is not there, try to download it from the RIP company's Web site.
- If it is not there, try to download it from HP's Web site.
- If you cannot find it anywhere, create a new substrate preset in the RIP. See [Add a new substrate type on page 32](#).

Add a new substrate type

This section is provided in case you decide to make your own substrate preset. Normally there is no need to do this if you can find ready-made presets for all the substrates that you use.

Summary

1. Select printer settings for your new substrate. See [Select printer settings and color profile on page 33](#).
2. Load the new substrate into the printer.
3. Disable the substrate advance sensor (OMAS) in your RIP software if the substrate is transparent or dark, or if the printer recommends doing so during the loading process.
4. Align the printheads. See the *Maintenance and troubleshooting guide*.
5. In your RIP software, open the HP diagnostic chart, which you can obtain from the Embedded Web Server at <http://ip-addr/hp/device/webAccess/images/new.tif>, where ip-addr is the IP address of your printer. Alternatively, you can find the chart on the Web under <http://www.hp.com/go/l25500/manuals/>.
6. Select the number of print passes. See [Select the number of passes on page 36](#).
7. Print the chart.
8. If you experience a substrate jam or noticed ink smears or substrate damage while printing, see the *Maintenance and troubleshooting guide*.

9. Check the quantity of ink and correct it if there is too much; see [Check the ink quantity on page 37](#). The print may not be completely dry at this stage; this is normal and not a problem.
10. After a little time, the print should be completely dry. If the ink smudges when touched, see the *Maintenance and troubleshooting guide*.
11. If you notice any print quality problems, see the *Maintenance and troubleshooting guide*.
12. If you would like to print faster, see [Faster printing on page 39](#).
13. You should use your RIP software to color-calibrate and color-profile the new substrate. See [Color calibration on page 39](#), [Color profiles on page 39](#) and the RIP documentation.

Select printer settings and color profile

The correct printer settings for your substrate may be available from your RIP vendor or substrate vendor. If not, you can start by copying printer settings from a generic or similar substrate. Substrates may be divided into the following families.

Substrate family	Description
Self-adhesive vinyl	PVC films with adhesive on one side, which can be white-finished or transparent. The liner can be paper- or plastic-based. There are two main manufacturing processes: calendering and casting. There are also variations such as perforated vinyl to be placed on windows. These substrates may need manual rather than automatic printhead alignment.
Banner	Usually a polyester mesh (or fabric) with PVC coating. There are also recyclable versions to cover the same applications (green banners). Banners can be frontlit or backlit.
Film	Usually a polyester film (although there are other materials such as PVC and PC) for backlit applications. They are typically translucent, although there are also transparent versions.
Fabric	Fabric substrates are usually composed of polyester fibers. Some fabrics come with a liner to prevent the ink from passing through the substrate. Very stiff fabrics (such as polyester canvases) are better loaded as banners.
Mesh	Usually a polyester mesh covered with PVC coating with holes. Some of these substrates may have a liner and be self-adhesive.
Paper-Aqueous	Paper-based (cellulose) substrates with or without coating, not compatible with solvent inks.
Paper-Solvent	Paper-based (cellulose) coated substrates, compatible with solvent inks, and usually with some water resistance.
HP Photorealistic	Paper-based (cellulose) coated substrates with gloss or matte finishing, heavier and more rigid than other paper-based substrates.

Here are some recommended default settings for each substrate family, which can be used as a starting point.

Substrate family	Drying temp.	Curing temp.	Heating airflow	Auto-tracking	Cutter	Substrate -advance adjust.	Input tension	Vacuum level
Self-adhesive vinyl	50	110	30	Yes	Yes	0	15	20
Banner	55	100	45	Yes	Yes	0	15	5
Film	55	95	60	Yes	Yes	0	15	20
Fabric	60	100	30	Yes	No	0	15	20
Mesh	55	95	30	Yes	Yes	0	15	15
Paper-Aqueous	45	70	30	Yes	Yes	0	15	20

Substrate family	Drying temp.	Curing temp.	Heating airflow	Auto-tracking	Cutter	Substrate-advance adjust.	Input tension	Vacuum level
Paper-Solvent	50	80	30	Yes	Yes	0	15	15
HP Photorealistic	50	100	30	Yes	Yes	0	15	30

The various settings mentioned above are described below.

Setting	Description	If too low	If too high
Drying temp.	The heat applied in the printing zone removes water and fixes the image to the substrate.	Print-quality defects such as banding, bleeding and coalescence may occur.	Thermal marks may be seen on the substrate; they may appear as vertical bands in some colors. The substrate may wrinkle on the platen, causing vertical banding, ink smears or substrate jams.
Curing temp.	Curing is needed to coalesce the latex, creating a polymeric film which acts as a protective layer, while at the same time removing the remaining co-solvents from the print. Curing is vital to ensure the durability of the printed images.	The print may emerge not fully polymerized, so that the ink smears when rubbed with a finger. The print may appear wet, after printing or later.	The substrate may wrinkle under the curing module, causing defects such as bubbles or liner detachment. The substrate wrinkles may also cause vertical banding or ink smears at the beginning of the following plot.
Heating airflow	Airflow helps to remove the evaporated water from the print zone and thus allows more efficient drying.	Print-quality defects such as banding, bleeding and coalescence may occur.	The printer may not reach the expected temperature in the print zone, causing defects such as banding, bleeding and coalescence. Poor text and line quality may be seen.
Auto-tracking	The substrate-advance sensor (also known as OMAS) is located under the print platen; it can track the substrate advance automatically.	Disable the sensor in the following cases: <ul style="list-style-type: none"> The substrate is porous and allows ink to pass through to the platen. Clean the sensor after using this substrate. You are instructed to do so by the front panel, because the sensor is dirty or unable to track this particular substrate. 	
Cutter	The printer's built-in cutter can cut the substrate automatically between each print.	Disable the cutter in the following cases: <ul style="list-style-type: none"> You want to use the take-up reel. You want to cut the substrate manually. The leading edge of the substrate tends to curl and cause substrate jams. 	
Substrate-advance adjust.	Your printer was calibrated at the factory to ensure that it advances the substrate accurately when using supported substrates in normal environmental conditions. However, you may find it useful to adjust the substrate advance when printing on unsupported substrates or in unusual but stable environmental conditions.	Dark lines appear when you use up to six passes. Graininess appears when you use eight or more passes.	White lines appear when you use up to six passes. Graininess appears when you use eight or more passes.

Setting	Description	If too low	If too high
Input tension	Tension is applied to the substrate from the input spindle. It needs to be constant over the full width of the substrate, thus substrate load is a critical operation.	The substrate skews and may become increasingly wrinkled in the printing zone. Also, substrate advance may be irregular, resulting in horizontal banding.	The substrate may be permanently deformed or damaged. Substrate advance problems may appear in extreme cases.
Vacuum level	The vacuum applied to the substrate at the printing zone helps to hold the substrate down on the print platen, keeping the distance to the printheads constant.	The substrate may lift up off the platen and touch the printheads. This can smear the printed image, cause a substrate jam or even damage the printheads.	For sticky substrates, friction could be too high and substrate advance irregular, resulting in horizontal banding or irregular grainy patches.

Here are some more advanced settings, which you are not recommended to change, unless you have problems that you cannot resolve any other way.

Substrate family	Warm-up drying temperature offset	Warm-up curing temperature offset	Cool-down drying temperature offset	Cool-down curing temperature offset	Minimum drying power
Self-adhesive vinyl	10	0	0	0	0.7
Banner	10	0	0	0	0.7
Film	5	0	0	0	0.7
Fabric	5	0	0	0	0.7
Mesh	10	0	0	0	0.7
Paper-Aqueous	5	0	0	0	0
Paper-Solvent	10	0	0	0	0.7
HP Photorealistic	10	0	0	0	0

The various settings mentioned above are described below.

Setting	Description	If too low	If too high
Warm-up drying temperature offset	The temperature that the substrate in the print zone must reach before printing starts.	Bleeding or coalescence may appear in the first 200-300 mm of the print.	A longer time to start printing is required. Vertical banding or ink smears may occur.
Warm-up curing temperature offset	The temperature that the substrate in the curing zone must reach before printing starts.	The beginning of the print is not fully dry, or looks oily.	Substrate degradation (bubbles, adhesive detachment) at the beginning of the print.
Cool-down drying temperature offset	The safe temperature at which the substrate can be under the drying module without being damaged. At the end of a job, the substrate is not stopped until this temperature is reached.	A long time is needed to finish the print.	The substrate at the beginning of the next print may be damaged, because it has stopped moving under too high a temperature. This case is uncommon.

Setting	Description	If too low	If too high
Cool-down curing temperature offset	The safe temperature at which the substrate can be under the curing module without being damaged. At the end of a job, the substrate is not stopped until this temperature is reached.	A long time is needed to finish the print.	The end of the print may be damaged if the cutter is disabled.
Minimum drying power	The minimum power applied in the drying module while printing, so the substrate does not cool too much in lightly inked areas.	A heavily inked area that comes after a lightly inked area will have bleeding or coalescence defects.	The substrate is damaged in blank or lightly inked areas of the print, especially with a high number of passes.

Select the number of passes

Increasing the number of passes will tend to improve the print quality but reduce the speed of printing.

Passes	Uni/bidir	Self-adhes. vinyl	Banner	High-quality paper-based	Bill-board	Offset	Mesh	Fabric	Film
Ink limit setting in RIP		Normal ink limit							High ink limit
4	Bidir	No	No	No	No	No	No	No	No
6	Bidir	No	Maybe	Maybe	Maybe	Yes	No	No	No
8	Bidir	Maybe	Yes	Yes	Yes	Yes	Yes	No	No
10	Bidir	Yes	Yes	Yes	Yes	Yes	Yes	No	No
12 to 16	Bidir	Yes	Yes	Yes	Yes	Yes	Yes	Yes	Yes
10 to 18	Unidir	Yes	Yes	Yes	Yes	Yes	Yes	Yes	Yes

Key

- **Unidir:** unidirectional
- **Bidir:** bidirectional
- **No:** not recommended
- **Maybe:** may be worth trying for extra speed
- **Yes:** recommended

Check the ink quantity

Check the printed chart in the following ways.

1. **Too much ink:** There are several possible symptoms of this problem.

- The last two or three scales of the plot look the same.

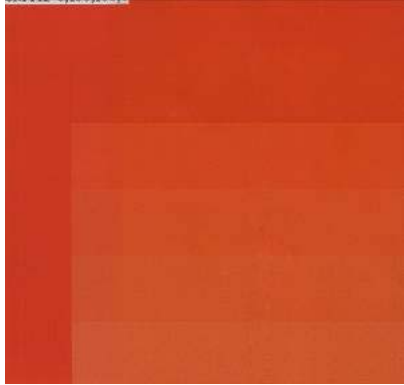

- Vertical banding.

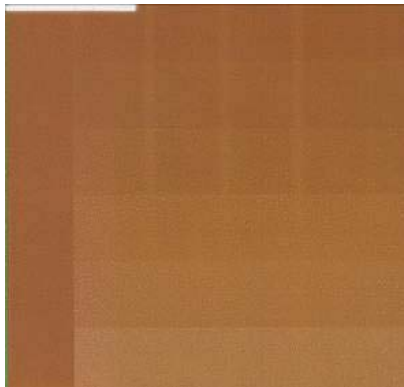

- Horizontal banding.

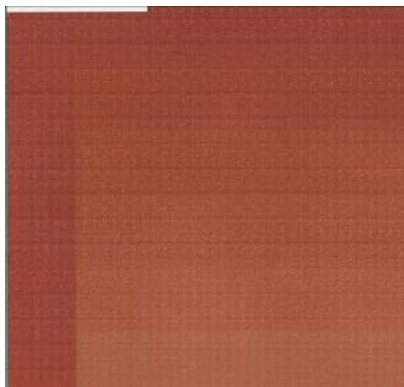

- Coalescence, grain.

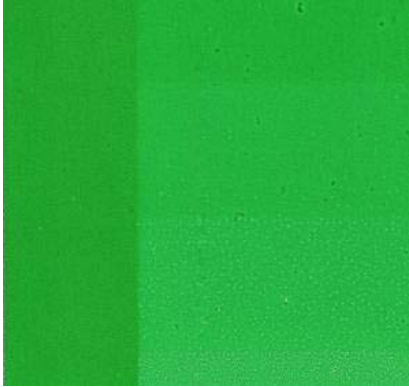

Try reducing the amount of ink in your RIP software, then reprint the chart and check again.

Also consider the following tips.

- You may have chosen a substrate preset that uses more ink than your substrate allows. Consult the substrate vendor's Web site and HP's Web site for the latest substrate presets and information.
- Consult your RIP documentation to make sure you are applying the right substrate ICC profile.
- Consult your RIP documentation on how to lower the total ink quantity of the preset.

2. **Correct amount of ink:** Each scale can be distinguished from the others, and there are no visible defects.

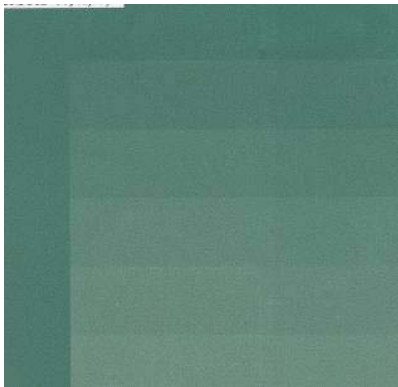

3. **Too little ink:** The whole chart looks washed out.

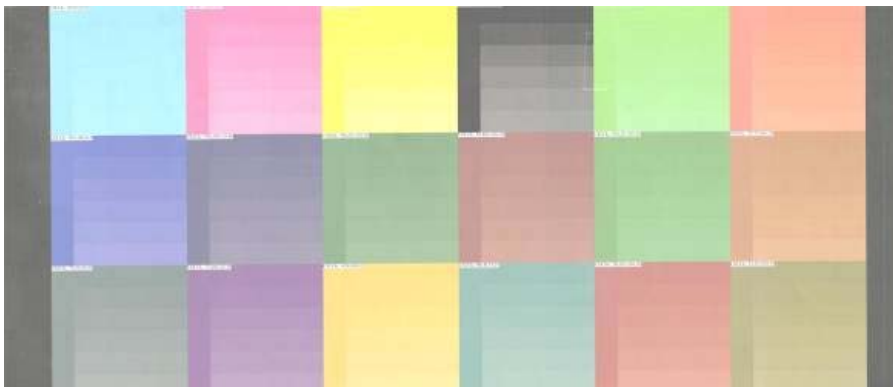

Try increasing the amount of ink in your RIP software, then reprint the chart and check again.

 **NOTE:** Backlit substrates normally require the use of the RIP's high ink limit option.

Faster printing

The obvious way to increase speed is to reduce the number of print passes, although this will tend to reduce print quality. Bear in mind the following considerations.

- With fewer than 10 passes, you may see an increase in grain.
- With 4 or 6 passes, the printer is more sensitive to substrate advance problems.
- With 4 or 6 passes, reducing the ink quantity may improve print quality.
- If you are using the high ink limit option, you must use at least 12 passes.
- As you reduce the number of passes, the best curing temperature may be more difficult to find, and may be more sensitive to the ambient temperature and humidity.

Here are some other suggestions for increasing the speed of printing.

- Concatenating prints saves time, because one can be sent while another is being printed.
- Disable the cutter. With most substrates, this saves some time at the end of the printing process.
- Increase the cool-down curing temperatures. This also saves some time at the end of the printing process, but may cause slight substrate deformation, depending on the substrate.

See also [Printer states on page 60](#).

Color calibration

The purpose of color calibration is to produce consistent colors with the specific printheads, inks and substrate that you are using, and in your particular environmental conditions. After color calibration, you can expect to get identical prints from your printer on different occasions.

Color calibration can be launched from your RIP software; see your RIP documentation for details.

In outline, the process consists of the following steps.

1. A calibration test chart is printed.
2. The HP Embedded Spectrophotometer (or, if you prefer, a different spectrophotometer) scans and measures the test chart.
3. The RIP uses the measurements to calculate the necessary correction factors for consistent color printing on that substrate.

Color profiles

Color calibration provides consistent colors, but consistent colors are not necessarily accurate. For instance, if your printer prints all colors as black, its colors may be consistent but they are not accurate.

In order to print accurate colors, it is necessary to convert the color values in your files to the color values that will produce the correct colors from your printer, your inks and your substrate. A color profile is a description of a printer, ink and substrate combination that contains all the information needed for these color conversions.

These color conversions are performed by your Raster Image Processor (RIP), not by the printer. For further information on the use of color profiles, see the documentation for your application software and for your RIP.

In addition to the color profiles used for printing, you may wish to calibrate and profile your monitor (display device), so that the colors you see on the screen relate more closely to those that you see on your prints.

5 Handle the ink system

Ink system components

Ink cartridges

The printer's six ink cartridges provide magenta, light magenta, black, yellow, light cyan and cyan ink to the printheads. Each cartridge has a capacity of 775 ml.

Ink cartridges require no maintenance or cleaning. When each ink cartridge is shaken vigorously before installation, and inserted correctly into its slot, the ink will flow to the printheads. Because the printheads control the amount of ink that is transferred to the page, high-quality printing results continue even when the ink levels are getting low.

△ **CAUTION:** Avoid touching pins, leads and circuitry when handling ink cartridges because these elements are sensitive to electrostatic discharge, which can reduce the life expectancy of the device.

Replace ink cartridges

You can highlight the  icon at any time to check the ink levels of all the ink cartridges.

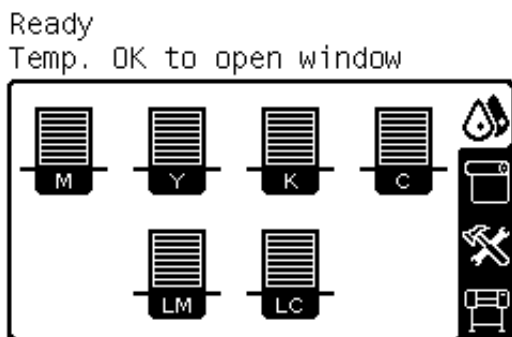

The front panel warns you when cartridge ink level is low. When a cartridge is empty, the printer stops printing and the front panel provides an explanation.

C cartridge is out of ink

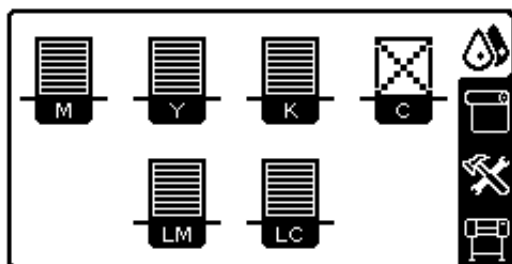

HP recommends that you replace the empty cartridge with a new HP cartridge. See [Order ink supplies on page 58](#) and [Replace an ink cartridge on page 43](#).

Although it is possible to use refilled or non-HP ink cartridges, either choice has several serious disadvantages:

- There is some risk of damaging the printer. In this case the printer warranty will not be valid for any printer repairs that are related to the cartridge, nor for any problems due to ink contamination.
- You will invalidate the warranty of all printheads of the same color used in the printer subsequently, unless and until the whole ink system (including ink tubes) is replaced.
- Print quality may be impaired.
- The printer will be unable to estimate the ink level in the cartridge, and will report it as empty.

If you decide to use refilled or non-HP ink cartridges, you will need to follow these instructions to make the printer use a cartridge that it believes to be empty.

1. Install the cartridge in the printer (see [Replace an ink cartridge on page 43](#)).
2. The front panel will complain that the cartridge is empty, and the cartridge removal process will start. Press the **Cancel** key to stop this automatic process.
3. At the front panel, select the  icon.
4. Highlight **Replace ink cartridges**, but do not select it.
5. Press the **Cancel** key and the **Up** key at the same time, and hold them down for at least two seconds.
6. The front panel will display a series of warning messages. In response to each message, press the **Cancel** key to cancel the process, or the **Select** key to confirm that you wish to continue.

When you have pressed **Select** in response to all warning messages, the front panel will give the usual ink cartridge status display, but the refilled or non-HP cartridge will be shown as empty with a warning sign.

Printheads

The printheads are connected to the ink cartridges. Each printhead has two ink cartridge connection points and two jet nozzles, which means that each printhead accommodates two ink cartridges. For example, the following printhead image indicates a printhead that draws and jets ink from the light magenta and magenta cartridges.

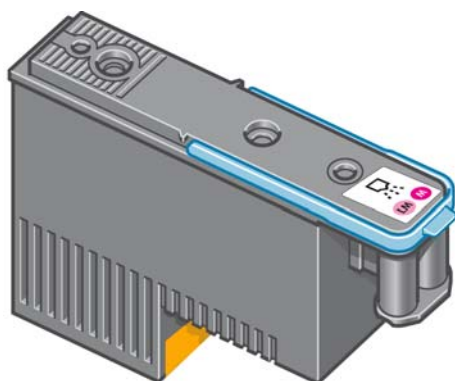

The printheads are extremely durable and do **not** need to be replaced every time an ink cartridge is replaced. They provide excellent results even when the ink cartridges contain a low level of ink.

To maintain optimum print quality, the printheads are automatically tested at regular intervals, and automatically serviced when necessary. This takes a little time and can occasionally delay printing.

When a printhead eventually needs to be replaced, the front panel will display a message.

-
- △ **CAUTION:** Avoid touching pins, leads, and circuitry when handling ink cartridges because these elements are sensitive to electrostatic discharge. Such devices are called ESD-sensitive devices. See [Glossary on page 66](#). Electrostatic discharges are one of the main hazards to electronics products. This type of damage can reduce the life expectancy of the device.
-

Printhead cleaning cartridge

The printhead cleaning cartridge cleans and maintains the printheads, and seals the printheads when they are not in use to prevent them from drying out.

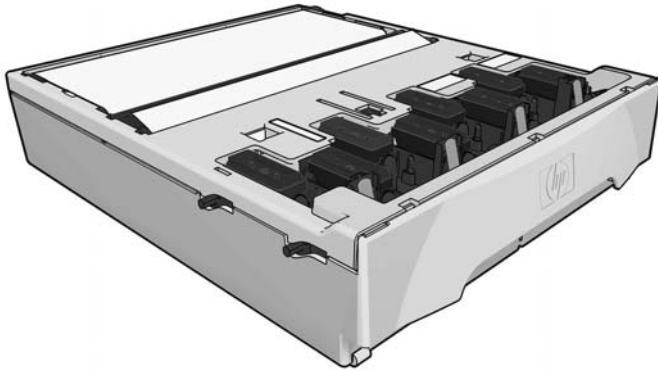

The cartridge contains a roll of cloth, which is used to clean the cartridges. You are notified when 90% of the roll has been used.

The printer will refuse to start a print job if it detects the end of the cleaning roll. You should then replace the printhead cleaning cartridge with a new one.

Ink funnel

The ink funnel collects waste ink produced during printhead servicing. It is important that this funnel is installed, as it prevents significant deposits of ink over various other printer parts.

From the ink funnel, the waste ink passes through a tube into the printhead cleaning container.

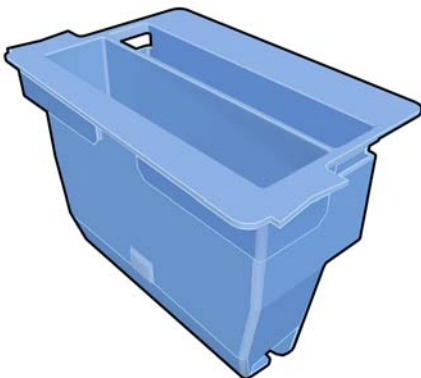

Printhead cleaning container

The printhead cleaning container stores waste ink collected by the ink funnel..



Ink system tips

For best results, always follow these guidelines:

- Install the ink cartridges, printheads and printhead cleaning cartridge before the warranty-ends date, which is printed on the product label and packaging.

 **NOTE:** The ink cartridges normally expire some time after the warranty ends. Refer to the ink cartridge information on the front panel for the expiration date.

- Follow the instructions on the front panel during installation.
- Allow the printer and the printhead cleaning cartridge to clean the printheads automatically.
- Avoid unnecessary removal of the ink cartridges and printheads.
- The ink cartridges should never be removed while the printer is printing. They should be removed only when the printer is ready for you to replace them. The front panel guides you through the replacement procedure (or see [Replace an ink cartridge on page 43](#)).
- Make sure that you comply with all applicable laws and regulations when disposing of ink system consumables.

 **NOTE:** Shake the ink cartridges and printheads vigorously before installing them. See [Replace an ink cartridge on page 43](#) and [Replace a printhead on page 47](#).

Work with ink system components

Replace an ink cartridge

Ink cartridges should be replaced for the following two reasons:

- The ink cartridge is very low and you want to replace it with a full cartridge for unattended printing. You can use the remaining ink in the first cartridge at a more convenient time.

- The ink cartridge is empty or faulty, and you must replace it to continue printing.

C cartridge is out of ink

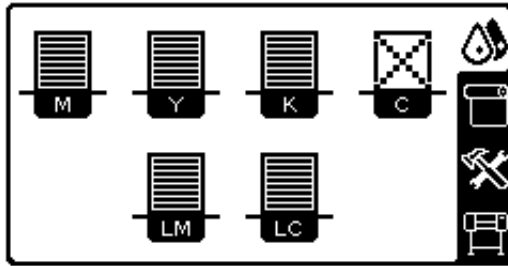

△ **CAUTION:** The procedure to remove an ink cartridge must be initiated from the front panel. Do not remove an ink cartridge until the front panel prompts you.

CAUTION: Remove an ink cartridge only if you are ready to insert another one.

△ **WARNING!** Make sure that the printer wheels are locked (the brake lever is pressed down) to prevent the printer from moving.

Remove an ink cartridge

1. On the printer's front panel, select the  icon, and then select **Replace ink cartridges**.

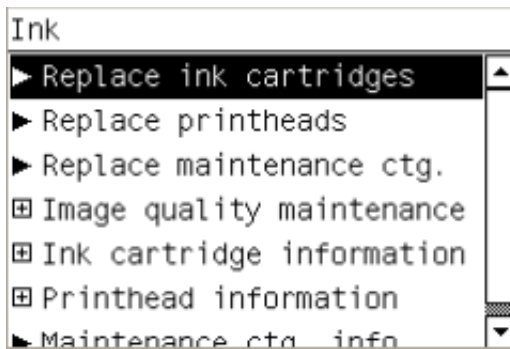

2. Grip the blue tab in front of the cartridge that you want to remove.



3. Pull the blue tab down and then pull it outwards, towards you.



4. The cartridge comes out, in its drawer.



5. Lift the cartridge out of its drawer.

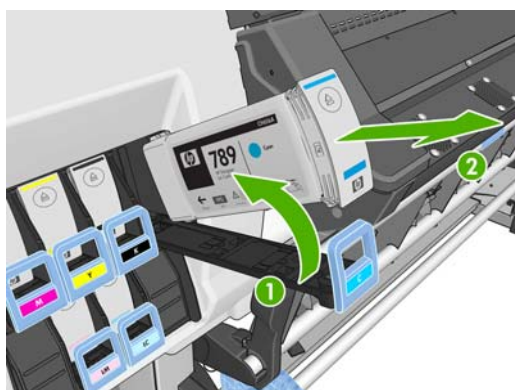

 **NOTE:** Avoid touching the end of the cartridge that is inserted into the printer, because the connection might be coated with ink.

NOTE: If necessary, store a partially-used ink cartridge in the same position as if it were inserted in the printer. Avoid using a partially-used cartridge that has been stored on its end.

6. The front-panel display identifies the missing ink cartridge.

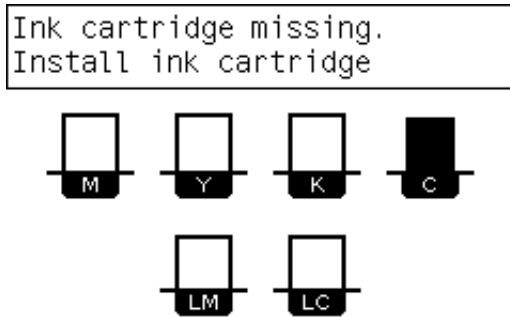

Insert an ink cartridge

1. Pick up the new ink cartridge and find the label that identifies the ink color. Hold the ink cartridge so that you can see the label at the top of the side that is facing you.
2. Check that the colored label above the empty slot in the printer matches the color of the label on the cartridge.
3. Shake the cartridge vigorously for about 15 seconds.

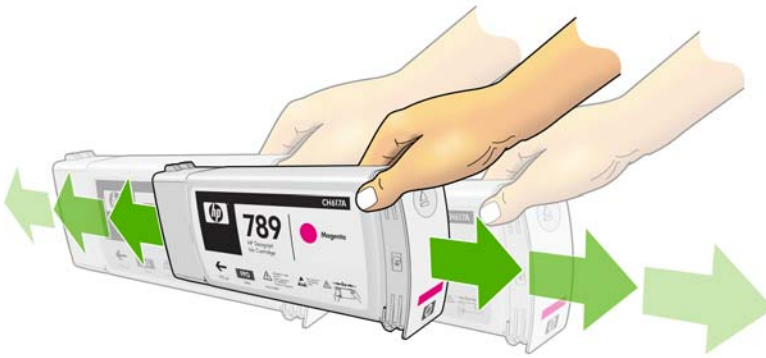

4. Insert the ink cartridge into the cartridge drawer.



- Slide the drawer and cartridge into the slot until they lock into position.



If you have difficulty, see the *Maintenance and troubleshooting guide*.

- The front-panel display confirms that all cartridges have been correctly inserted.

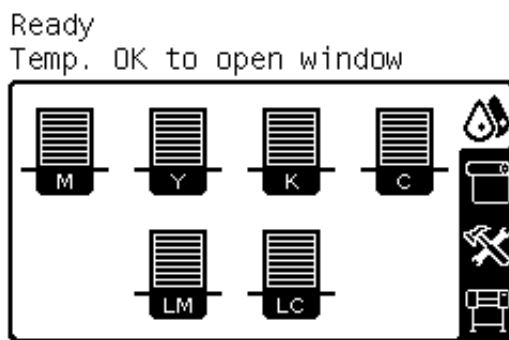

Replace a printhead

Printhead replacement must be performed after the printer has been turned on with the hard power switch at the back of the printer.

- ⚠ **WARNING!** Make sure that the printer wheels are locked (the brake lever is pressed down) to prevent the printer from moving.

WARNING! Make sure the printer has cooled down before removing a printhead. The printer will beep if it is still hot.

Remove a printhead

1. On the printer's front panel, select the  icon, and then select **Replace printheads**.

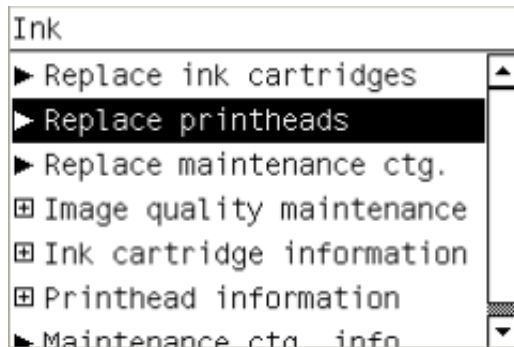

2. The carriage moves to the removal position.

△ **CAUTION:** If the carriage remains in the removal position for more than 3 minutes without inserting or removing any printheads, it will attempt to return back to its home position to the right.

3. When the carriage has stopped moving, the front panel prompts you to open the printer window. Unlock the window and open it.

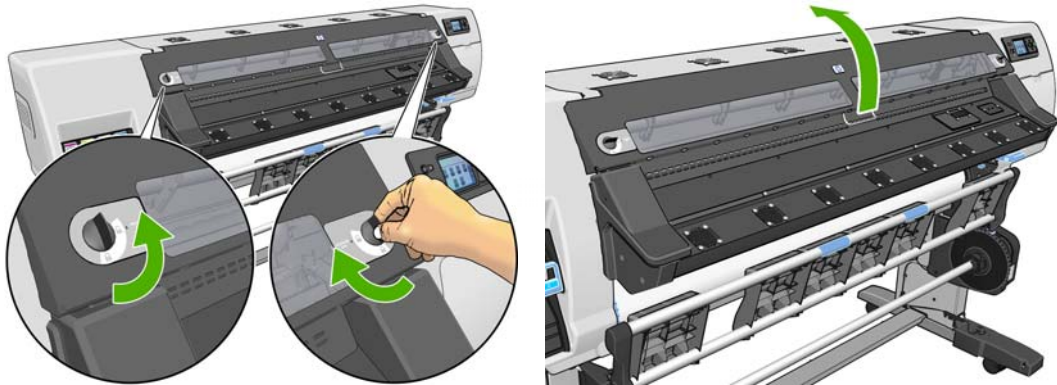

4. Locate the carriage on the right side of the printer.

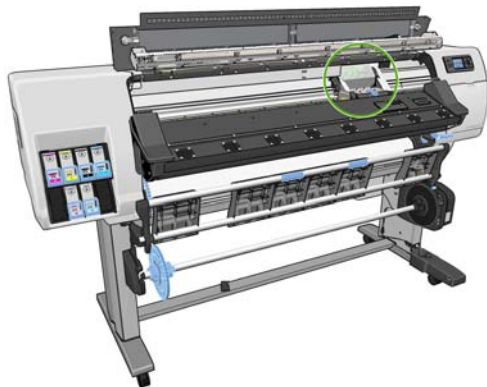

5. Pull up and release the latch on top of the carriage.

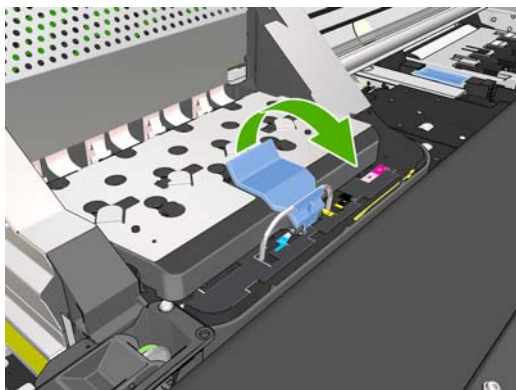

6. Lift up the cover. This provides access to the printheads.

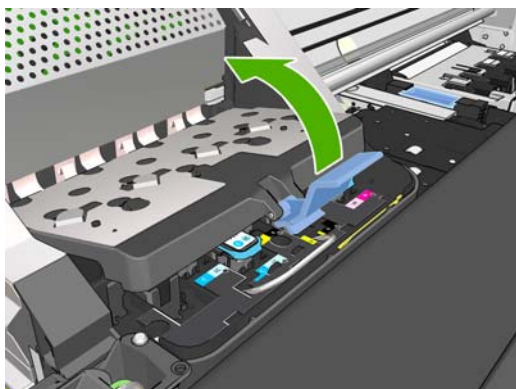

7. To remove a printhead, lift up the blue handle.

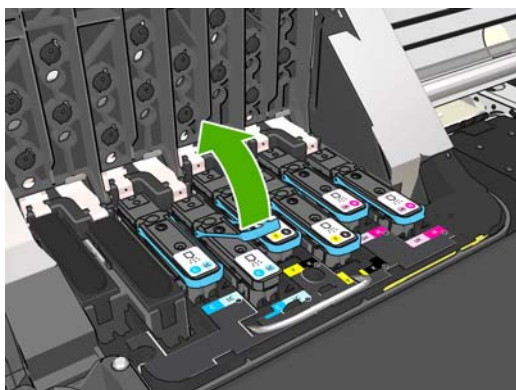

8. Using the blue handle, gently disengage the printhead.

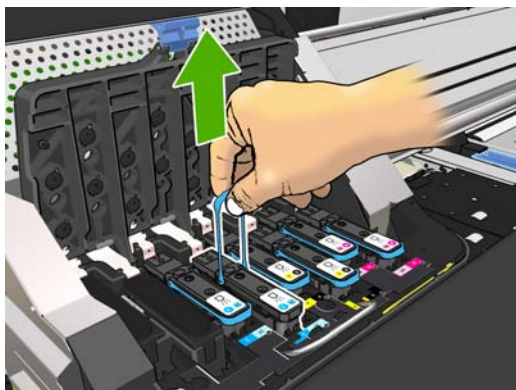

9. Gently pull the blue handle upward until the printhead is released from the carriage.

△ **CAUTION:** Do not pull abruptly. That action can damage the printhead.

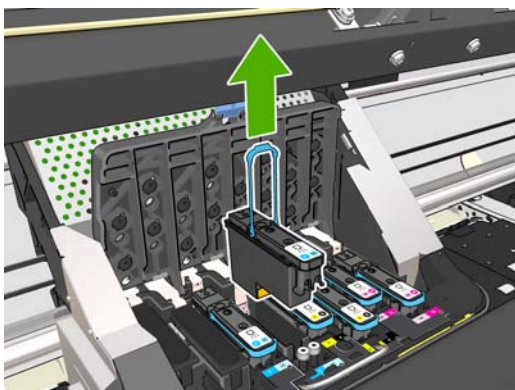

10. The front-panel display identifies the missing printhead.

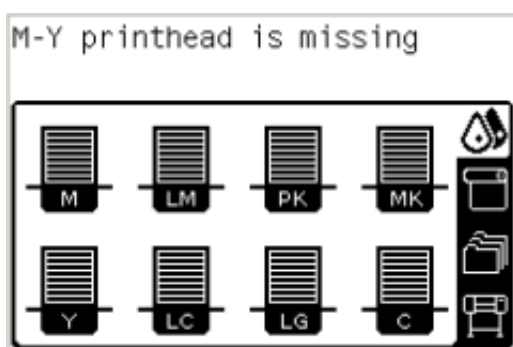

Insert a printhead

1. If the printhead is new, shake it vigorously before removing the protective caps. Hold the printhead upright (with the protective caps facing down) and shake the printhead vigorously in a smooth up and down motion for about 15 seconds.

📄 **NOTE:** Be careful not to strike the printhead against anything while shaking it, because this could cause damage.



2. Remove the orange protective caps by pulling them down.

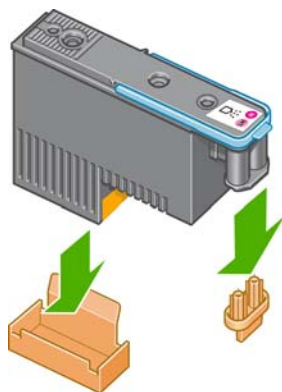

3. The printhead is designed to prevent you from accidentally inserting it into the wrong slot. Check that the colored label on the printhead matches the colored label of the carriage slot into which the printhead is to be inserted.
4. Insert the new printhead into its correct slot in the carriage.

△ **CAUTION:** Insert the printhead slowly and vertically, straight down. It can be damaged if you insert it too quickly, or at an angle, or if you rotate it as you insert it.

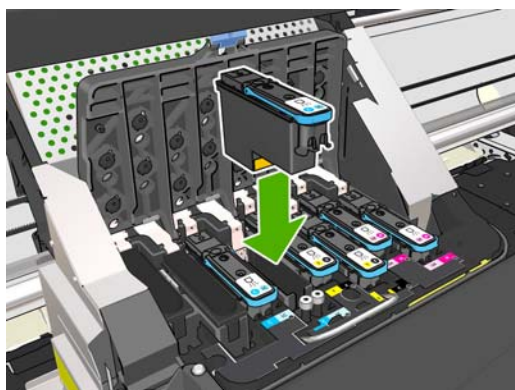

5. Push down as indicated by the arrow.

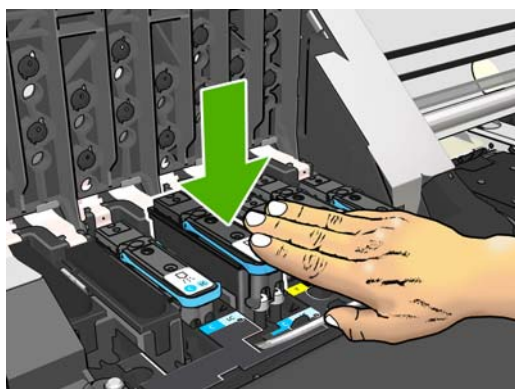

△ **CAUTION:** You might feel some resistance when installing the new printhead, so you need to press it down firmly but smoothly. You should hear a beep and see confirmation on the front-panel display that the printhead has been inserted. If you have difficulty, See the *Maintenance and troubleshooting guide*.

6. Insert all of the other printheads that need to be installed, and close the carriage cover.

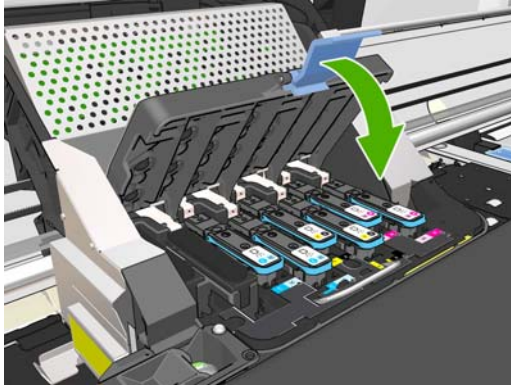

7. Make sure that the end of the latch catches the wire loop on the near side of the carriage.

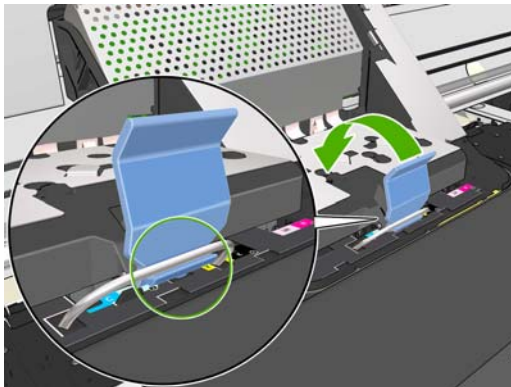

8. Lower the latch to rest on the carriage cover.

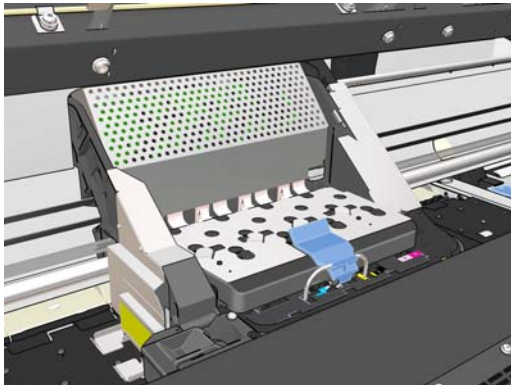

When all of the printheads have been inserted correctly and the printer has accepted them, the printer beeps.

 **NOTE:** If the printer does not beep when you insert the printhead and the **Replace** message appears on the front-panel display, you might need to reinsert the printhead.

9. Close and lock the printer window.

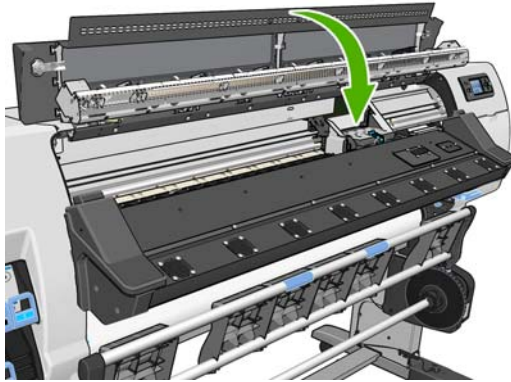

10. The front-panel display confirms that all of the printheads are correctly inserted. The printer starts checking and preparing the printheads. The default routine process, when all printheads are changed, takes up to 18 minutes. If the printer identifies a problem when preparing the printheads, the process takes longer, up to 30 minutes. For a single printhead insertion, the time varies between 10 and 20 minutes. After all printheads are checked and prepared, the printhead realignment procedure runs automatically if substrate is loaded. See the *Maintenance and troubleshooting guide*.

Replace the printhead cleaning kit

When the front panel prompts you to replace the printhead cleaning kit, you should replace first the printhead cleaning cartridge, then the ink funnel, then the printhead cleaning container.

Replace the printhead cleaning cartridge

A message appears on the front panel when the printhead cleaning cartridge is almost full, and again when it is completely full and must be changed. Follow these precautions when removing a printhead cleaning cartridge:

- Be careful not to get ink on your hands. Ink may be on, around and inside the replaced printhead cleaning cartridge.
- Always handle and store the replaced printhead cleaning cartridge upright to avoid spilling any ink.

⚠ **WARNING!** Make sure that the printer wheels are locked (the brake lever is pressed down) to prevent the printer from moving.

Remove the printhead cleaning cartridge

1. On the printer's front panel, select the  icon, then select **Replace PH cleaning kit**.

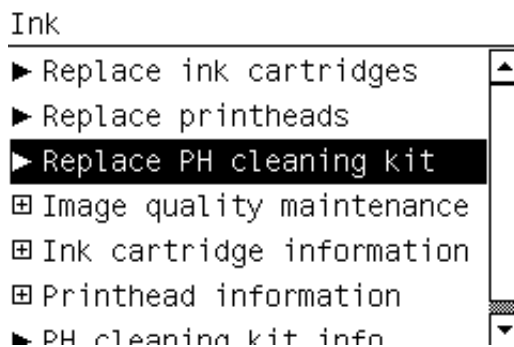

2. The printhead cleaning cartridge is located in a slot underneath the front panel, at the front of the printer. Open the door.

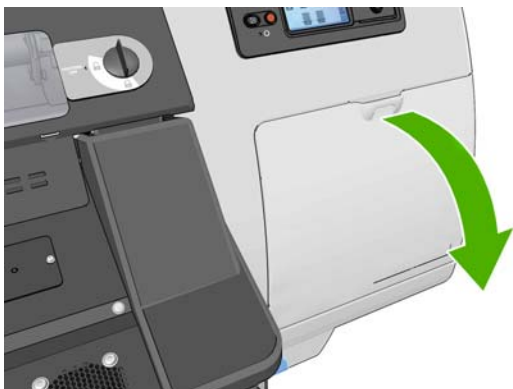

3. The printhead cleaning cartridge has a handle on the front. To remove the cartridge, press inward and upward as indicated by the arrow, until the cartridge is released.



4. Lift up the printhead cleaning cartridge to remove it from the slot, and slide it out.



The plastic bag in which the new printhead cleaning cartridge comes can be used to dispose of the old printhead cleaning cartridge.

Insert the printhead cleaning cartridge

1. Remove the plastic cover from the new printhead cleaning cartridge.

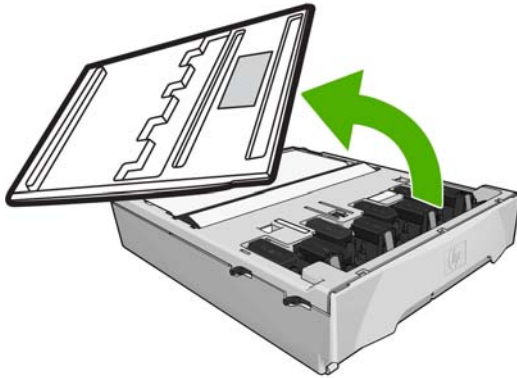

2. Insert the printhead cleaning cartridge into the slot, in the direction indicated by the arrow.

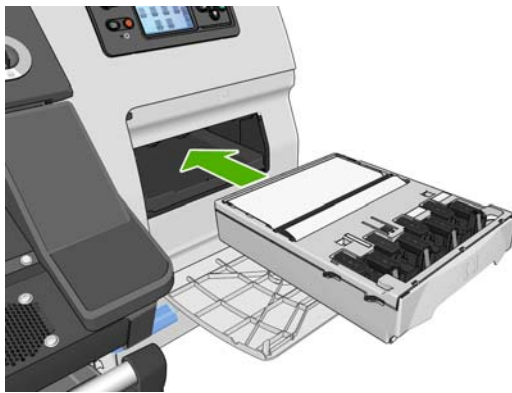

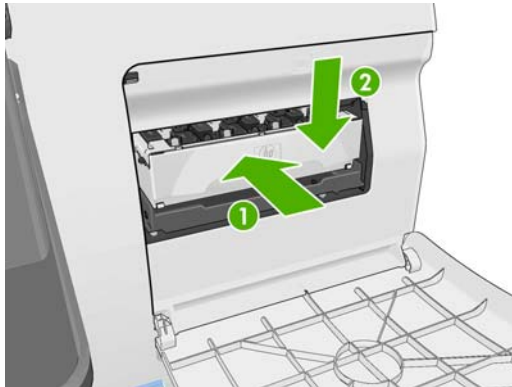

3. When the printhead cleaning cartridge has been pushed all the way in, press inwards and downwards as indicated, until it clicks into place.

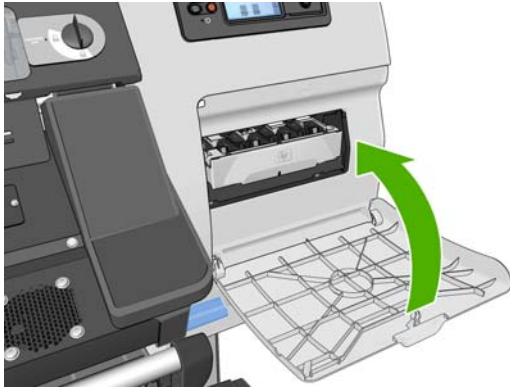

 **NOTE:** The front panel will not show the new printhead cleaning cartridge until the door is closed.

4. When you have inserted the printhead cleaning cartridge into the printer, close the door.



 **NOTE:** The printer needs all the ink cartridges, printheads and printhead cleaning cartridge to be installed before it can continue.

5. If no substrate is loaded, the front panel instructs you to load some.

Make sure that the printer window and the printhead cleaning cartridge door are closed. The printer will not print while these are open.

When you have replaced the printhead cleaning cartridge, the ink funnel and printhead cleaning container must also be replaced.

Replace the ink funnel

After you have replaced the printhead cleaning container, the front panel asks you to replace the ink funnel.

1. Unlock and open the window.

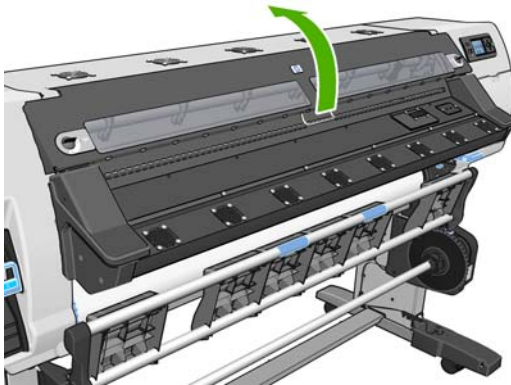

2. Locate the ink funnel.

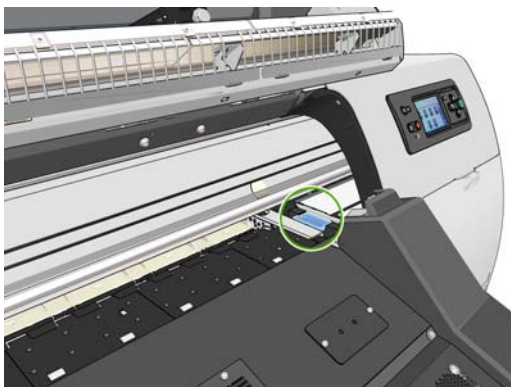

3. Grip the ink funnel.

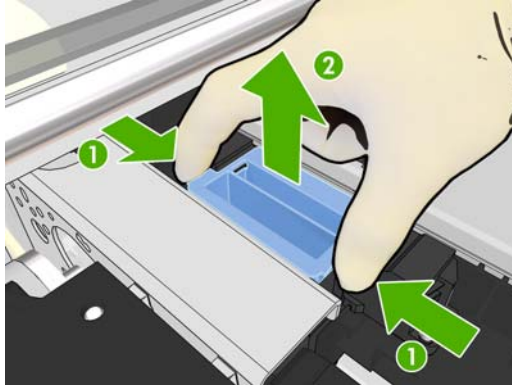

4. Remove the ink funnel.

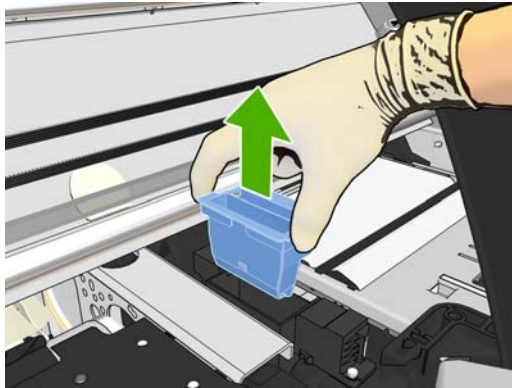

5. Insert the new ink funnel.

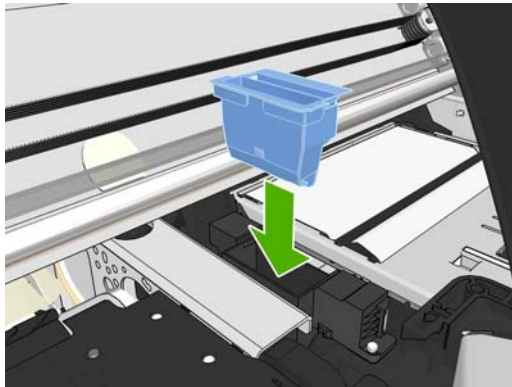

6. Press it into place.

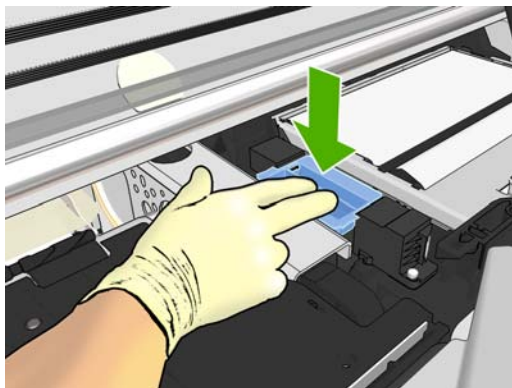

7. Close and lock the window.

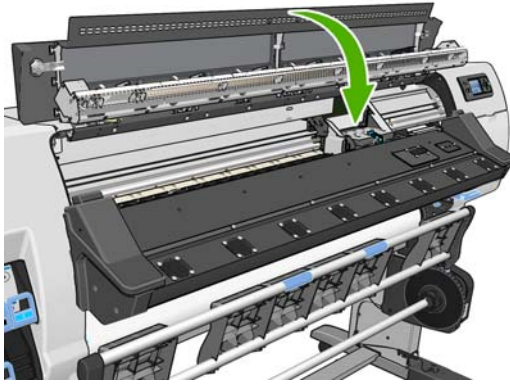

Replace the printhead cleaning container

△ **CAUTION:** You are recommended to wear gloves.

1. Remove the printhead cleaning container.

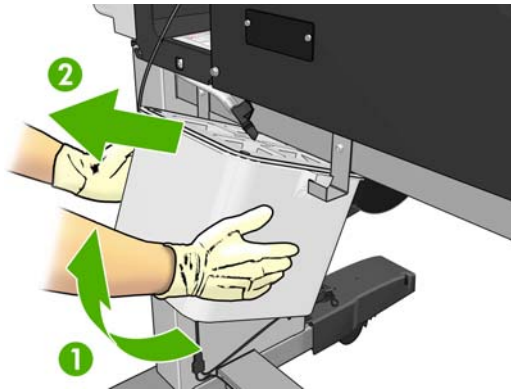

2. Insert the new printhead cleaning container.
3. Ensure that the tube is pointing into the center of the container.

Order ink supplies

You can order the following ink supplies for your printer.

Table 5-1 Ink cartridges

Cartridge	Capacity (ml)	Part number
HP 789 Black Latex Designjet Ink Cartridge	775	CH615A
HP 789 Cyan Latex Designjet Ink Cartridge	775	CH616A
HP 789 Magenta Latex Designjet Ink Cartridge	775	CH617A
HP 789 Yellow Latex Designjet Ink Cartridge	775	CH618A
HP 789 Light Cyan Latex Designjet Ink Cartridge	775	CH619A
HP 789 Light Magenta Latex Designjet Ink Cartridge	775	CH620A

Table 5-2 Printheads

Printhead	Part number
HP 789 Yellow/Black Printhead	CH612A
HP 789 Cyan/Light Cyan Printhead	CH613A
HP 789 Light Magenta/Magenta Printhead	CH614A

Table 5-3 Printhead cleaner

Printhead cleaner	Part number
HP 789 Printhead Cleaning Kit (contains a printhead cleaning cartridge and an ink funnel)	CH621A
HP 789 Printhead Cleaning Container	CH622A

6 Print options

Printer states

The printer may be in any one of the following states; some of them require waiting.

- **Ready (cold):** The printer is powered on but has not printed yet, and the heaters are not turned on.
- **Preparing to print:** The printer is warming up the heaters and preparing the printheads to print. This takes 1 to 8 min.
- **Printing**
- **Curing:** This takes 1.5 to 5 min.
- **Finishing:** The printer is cooling down and preparing for stand-by. This takes 0.5 to 5 min.
- **Ready (hot):** The printer is ready and the heaters are in stand-by.
 - If a new job arrives the printer goes to **Preparing to print**.
 - If there is no new job in a period of 10 minutes, the heaters turn off and the printer goes to **Ready (cold)**.

If jobs of the same print mode as the already-printed file are sent while the printer is **Curing** (if the cutter is not enabled) or **Finishing**, the printer goes to **Preparing to print**.

To save time between prints, concatenate jobs with the same print mode (same number of passes) and turn the cutter off to skip the **Curing** and **Finishing** states. You can also use nesting to print several jobs in the same workflow.

Even if the cutter is on or successive jobs use different print modes, it is better to print them all together without delays to minimize the time spent in **Preparing to print**.

Change margins

The printer margins determine the area between the edges of your image and the edges of the substrate.

The margins for a particular print job are selected in the RIP software; if the job exceeds the substrate width, it will be clipped.

In addition, the front panel offers three settings for the bottom margin: normal, small and extended; see [Table 8-4 Margins on page 63](#). This selection only applies to single prints when the cutter is not in use. The bottom margin is not applied between several prints sent at the same time.

To set the bottom margin at the front panel, select the  icon, and then **Substrate handling options > Extra bottom margin**.

 **NOTE:** If a larger margin is set in the RIP, it overrides the bottom margin set in the front panel.

Request the printer's internal prints

The internal prints provide various kinds of information about your printer. Request these prints from the front panel, without using a computer.

Before requesting any internal print, make sure that substrate is loaded and that the **Ready** message appears on the front-panel display.

To print an internal print, select the  icon, **Internal prints**, and then select the type of internal print that you want.

The following internal prints are available:

- Menu map: Shows details of all the front-panel menus.
- Configuration: Shows all the current front-panel settings.
- Usage report: Shows estimates of the total number of prints, number of prints by substrate family, number of prints by print-quality option, and total amount of ink used per color. The accuracy of these estimates is not guaranteed.
- Service information: Provides information that service engineers require.

7 Accessories

Order accessories

The following accessories can be ordered for your printer.

Name	Product number
HP Designjet L25500 42-inch Spindle (spare spindles ease the process of switching between different substrates)	CQ154A
HP Designjet L25500 60-inch Spindle (spare spindles ease the process of switching between different substrates)	CQ155A
HP Designjet L25500 User Maintenance Kit	CQ201A

8 Printer specifications

Functional specifications

Table 8-1 HP No. 789 ink supplies

Printheads	Yellow/black, cyan/light cyan and light magenta/magenta
Printhead cleaning kit and printhead cleaning container	Non-color-specific
Ink cartridges	Yellow, black, magenta, light magenta, cyan and light cyan. All cartridges contain 775 ml of ink.

Table 8-2 Substrate sizes

	Minimum	Maximum
Width	584 mm (23 in) Narrow substrate: 254 mm (10 in)	1067 mm (42 in) or 1524 mm (60 in)
Length	420 mm (16.5 in)	Roll with maximum external diameter of 180 mm (7.1 in)

Table 8-3 Print resolutions

Ink level	Number of passes	Halftone resolutions (dpi)	Print resolutions (dpi)
100%	4–16	300, 600	600×1200
	18	1200	1200×1200
200%	10–16	300, 600	600×1200

The table above shows the resolutions supported by the printer. See your RIP documentation to find the resolutions supported by your RIP.

Table 8-4 Margins

Side margins	5 mm = 0.2 inches
Top margin (leading edge)	5 mm = 0.2 inches
Bottom margin (trailing edge)	5 mm = 0.2 inches (small)
	100 mm = 3.9 inches (normal)
	150 mm = 5.9 inches (extended)

Table 8-5 Mechanical accuracy

The printer's mechanical accuracy is 0.1%, but some substrates (in particular PVC banners) may shrink up to 2%.

Physical specifications

Table 8-6 Printer physical specifications

Weight (including stand)	161 kg (42-in printer)
	181 kg (60-in printer)
Width	1985 mm (42-in printer)
	2465 mm (60-in printer)
Depth	690 mm
Height	1370 mm

Memory specifications

Table 8-7 Memory specifications

Memory (DRAM) supplied	256 MB
Memory (DRAM) maximum	512 MB
Hard disk	50 GB

Power specifications

 **NOTE:** An electrician is required for the setup and configuration of the building electrical system used to power the printer and also for printer installation. Make sure that your electrician is appropriately certified according to local regulations and supplied with all the information regarding the electrical configuration.

Your printer requires that the following electrical components be supplied and installed by the customer, according to the National Electrotechnical Code (NEC).

Table 8-8 Single phase line specifications

	60-in printer	42-in printer
Number of power cords	2	2
Input voltage	220-240 V~ (-10%+6%)	200-240 V~ (-10%+6%)
Input frequency	50 / 60 Hz	50 / 60 Hz
Power consumption	4.8 kW (overall consumption for both power cords)	3.5 kW (overall consumption for both power cords)
Maximum load current (per power cord)	15 A	13 A

Ecological specifications

This product complies with European Union WEEE and RoHS Directives.

ENERGY STAR and the ENERGY STAR mark are registered U.S. marks. To determine the ENERGY STAR® qualification status of these product models. See: <http://www.hp.com/go/energystar>.

For up-to-date ecological specifications of your printer, please go to <http://www.hp.com/> and search for “ecological specifications”.

Environmental specifications

Table 8-9 Printer environmental specifications

Relative humidity range for best print quality	20–80%, depending on substrate type
Temperature range for best print quality	18 to 25°C (64 to 77°F), depending on substrate type
Temperature range for printing	15 to 30°C (59 to 86°F)
Temperature range when not in operation	-25 to +55°C (-13 to +131°F)
Temperature gradient	no more than 10°C/h (18°F/h)
Maximum altitude when printing	3000 m (10000 ft)

 **NOTE:** The printer must be kept indoors.

NOTE: If the printer or ink cartridges are moved from a cold location to a warm and humid location, water from the atmosphere can condensate on the printer parts and cartridges and can result in ink leaks and printer errors. In this case, HP recommends that you wait at least 3 hours before turning on the printer or installing the ink cartridges, to allow the condensate to evaporate.

Acoustic specifications

Table 8-10 Printer acoustic specifications

Idle sound power	≤ 5.1 B (A)
Operating sound power	≤ 7.5 B (A)
Idle sound pressure	≤ 39 dB (A)
Operating sound pressure	≤ 56 dB (A)

Glossary

Airflow

Air is blown through the printing zone to speed up the drying process. Too much or too little airflow may cause print quality defects.

Back tension

The backwards tension applied to the substrate by the input spindle, which must be constant across the width of the substrate. Too much or too little tension may cause substrate deformation and print quality defects.

Bidirectional

Bidirectional printing means that the printheads print while moving in both directions. This increases the speed of printing but may reduce print quality.

Bleeding

A print-quality defect that occurs when the ink spreads on the substrate across areas of different colors.

Coalescence

A print-quality defect that occurs when the ink spreads on the substrate within an area of the same color.

Cockle

A substrate condition in which it is not lying perfectly flat, but rises and falls slightly in shallow waves.

Color accuracy

The ability to print colors that match the original image as closely as possible, given the fact that all devices have a limited color gamut and might not be able to match certain colors precisely.

Color consistency

The ability to print the same colors in a particular print job, from print to print and from printer to printer.

Curing

The substrate is heated in the curing zone to coalesce the latex, creating a polymeric film which acts as a protective layer, while at the same time removing the remaining co-solvents from the print. Curing is vital to ensure the durability of the printed images. Too high or too low a curing temperature may cause print quality defects.

Cutter

A printer component that slides back and forth across the platen to cut the substrate.

Drying

The substrate is heated in the printing zone to dry the ink and fix the image to the substrate. Too high or too low a drying temperature may cause print quality defects.

Firmware

Software that controls your printer's functionality and is stored semi-permanently in the printer (it can be updated).

Gamut

The range of colors and density values reproducible on an output device, such as a printer or monitor.

I/O

Input/Output: this term describes the passing of data between one device and another.

ICC

The International Color Consortium, a group of companies that have agreed on a common standard for color profiles.

Ink density

The relative amount of ink that is deposited on the substrate per unit of area.

IP address

A unique identifier that identifies a particular node on a TCP/IP network. It consists of four integers separated by dots.

LED

Light-Emitting Diode: a semiconductor device that emits light when electrically stimulated.

Minimum drying power

The minimum heat applied in the printing zone so that the substrate does not cool too much in lightly-inked areas. Low minimum power may cause print quality defects; high minimum power may damage the substrate, especially with a high number of passes and in blank or lightly-inked areas.

Nozzle

One of many tiny holes in a printhead through which ink is deposited onto the substrate.

Passes

The number of print passes specifies how many times the printheads will print on the same area of substrate. A higher number of passes tends to improve print quality and printhead health, but reduces the speed of printing.

Platen

The flat surface within the printer over which the substrate passes while it is being printed on.

Printhead

A removable printer component that takes ink of one or more colors from the corresponding ink cartridge(s) and deposits it on the substrate, through a cluster of nozzles.

Spindle

A rod that supports a roll of substrate while it is being used for printing.

Substrate

A thin, flat material designed to be printed on, made of paper or other materials.

Substrate advance compensation

A slight adjustment to the amount of substrate advance between print passes, to compensate for the characteristics of different substrate types. The printer normally performs this adjustment automatically, but may need to be recalibrated for substrates not supported by HP, or for an unusual ambient temperature or humidity. Incorrect substrate advance compensation may cause banding with fewer than 8 passes, or graininess with 8 passes or more.

Unidirectional

Unidirectional printing means that the printheads print while moving in only one direction, which may improve print quality. In general, increasing the number of passes is a better way of improving print quality.

Vacuum pressure

The substrate is held flat against the platen by vacuum suction. Too much or too little suction may cause print quality defects. Too little suction may also cause a substrate jam or damage the printheads.

Index

A

accessories
 order 62
acoustic specifications 65
add new substrate 32

C

calibration
 color 33
caution 3
color calibration 33
color profiles 33
components of printer 5
connect the printer
 connection method 10
contrast in front panel 13

D

downloading substrate
 presets 32

E

e-mail alerts 13
ecological specifications 64
Embedded Web Server
 access 8
 e-mail alerts 13
 language 14
environmental specifications 65

F

faster printing 33
features of printer 4
front panel
 contrast 13
 language 12
 units 13
front view 5
functional specifications 63

H

hard disk specification 64

I

ink cartridge
 about 40
 ordering 40
 refilling 40
 replacing 40
 specification 63
ink funnel
 about 42
 replacing 56
ink system tips 43
internal prints 61

L

labels, warning 3
language 12
loading roll into printer 15
loading roll onto spindle 16
loading thick substrates 20
loading thin substrates 20

M

margins
 changing 60
 specification 60
mechanical accuracy 64
memory specifications 64

O

order
 accessories 62
 ink cartridges 40
 printhead cleaner 59
 printheads 59

P

physical specifications 64
power specifications 64
print resolution 63
printer states 39
printer's main components 5
printer's main features 4
printhead
 about 41

 ordering 59
 replacing 43
 specification 63
printhead cleaner
 specification 63
printhead cleaning cartridge
 about 42
 replacing 53
printhead cleaning container
 about 42
 replacing 58
printhead cleaning kit
 replacing 53
printing delays 39
printing faster 33

R

rear view 6
refilling ink cartridges 40
resolution 63
restart the printer 12

S

safety labels 3
safety precautions 1
sleep mode wait time 13
specifications
 acoustic 65
 ecological 64
 environmental 65
 functional 63
 hard disk 64
 ink supplies 63
 margins 60
 mechanical accuracy 64
 memory 64
 physical 64
 power 64
 print resolution 63
 substrate size 63
substrate
 add new 32
 displaying information 31

- overview 15
- storage 31
- supported families 15
- tips 15
- substrate presets
 - downloading 32
- substrate sizes (max & min) 63

T

- take-up reel
 - motor 7
 - using 21
- turn the printer on/off 7

U

- unloading roll from printer 15
- use the take-up reel 21

W

- warning 3
- warning labels 3