HP 8517B S-Parameter Test Set

Operating and
Service Manual

Notice

The information contained in this document is subject to change without notice.

Hewlett-Packard makes no warranty of any kind with regard to this material, including, but not limited to, the implied warranties of merchantability and fitness for a particular purpose. Hewlett-Packard shall not be liable for errors contained herein or for incidental or consequential damages in connection with the furnishing, performance, or use of this material.

Hewlett-Packard assumes no responsibility for the use or reliability of its software on equipment that is not furnished by Hewlett-Packard.

This document contains proprietary information which is protected by copyright. All rights are reserved. No part of this document may be photocopied, reproduced, or translated to another language without prior written consent of Hewlett-Packard Company.

Restricted Rights Legend

Use, duplication, or disclosure by the U.S. Government is subject to restrictions as set forth in subparagraph (c)(1)(ii) of the Rights in Technical Data and Computer Software clause at DFARS 252.227-7013 for DOD agencies, and subparagraphs (c)(1) and (c)(2) of the Commercial Computer Software Restricted Rights clause at FAR 52.227-19 for other agencies.

Hewlett-Packard Company
Santa Rosa Systems Division
1400 Fountaingrove Parkway
Santa Rosa, CA 95403-1799, U.S.A.

© Copyright Hewlett-Packard Company 1997, 1998

What You'll Find in This Manual...

HP 8517B S-Parameter Test Set

- Chapters 1 and 2** • Test set description and installation information
- Chapters 3 and 4** • Principles of operation and specifications
- Chapters 5, 6, and 7** • Troubleshooting, replacement procedures, and replaceable parts information

Warranty

Certification

Hewlett-Packard Company certifies that this product met its published specifications at the time of shipment from the factory. Hewlett-Packard further certifies that its calibration measurements are traceable to the United States National Institute of Standards and Technology (NIST, formerly NBS), to the extent allowed by the Institute's calibration facility, and to the calibration facilities of other International Standards Organization members.

Warranty

This Hewlett-Packard system product is warranted against defects in materials and workmanship for a period corresponding to the individual warranty periods of its component products. Instruments are warranted for a period of one year. During the warranty period, Hewlett-Packard Company will, at its option, either repair or replace products that prove to be defective.

Warranty service for products installed by HP and certain other products designated by HP will be performed at Buyer's facility at no charge within HP service travel areas. Outside HP service travel areas, warranty service will be performed at Buyer's facility only upon HP's prior agreement and Buyer shall pay HP's round trip travel expenses. In all other areas, products must be returned to a service facility designated by HP.

For products returned to HP for warranty service, Buyer shall prepay shipping charges to HP and HP shall pay shipping charges to return the product to Buyer. However, Buyer shall pay all shipping charges, duties, and taxes for products returned to HP from another country.

HP warrants that its software and firmware designated by HP for use with an instrument will execute its programming instructions when properly installed on that instrument. HP does not warrant that the operation of the instrument, or software, or firmware will be uninterrupted or error free.

LIMITATION OF WARRANTY. The foregoing warranty shall not apply to defects resulting from improper or inadequate maintenance by Buyer, Buyer-supplied software or interfacing, unauthorized modification or misuse, operation outside of the environmental specifications for the product, or improper site preparation or maintenance.

NO OTHER WARRANTY IS EXPRESSED OR IMPLIED. HP SPECIFICALLY DISCLAIMS THE IMPLIED WARRANTIES OR MERCHANTABILITY AND FITNESS FOR A PARTICULAR PURPOSE.

EXCLUSIVE REMEDIES. THE REMEDIES PROVIDED HEREIN ARE BUYER'S SOLE AND EXCLUSIVE REMEDIES. HP SHALL NOT BE LIABLE FOR ANY DIRECT, INDIRECT, SPECIAL, INCIDENTAL, OR

CONSEQUENTIAL DAMAGES, WHETHER BASED ON CONTRACT, TORT, OR ANY OTHER LEGAL THEORY.

Assistance

Product maintenance agreements and other customer assistance agreements are available for Hewlett-Packard products.

For assistance, call your local Hewlett-Packard Sales and Service Office (refer to “Service and Support”).

Service and Support

Any adjustment, maintenance, or repair of this product must be performed by qualified personnel. Contact your customer engineer through your local HP Service Center. You can find a list of HP Service Centers on the web at <http://www.hp.com/go/tmdir>.

If you do not have access to the Internet, one of these HP centers can direct you to your nearest HP representative:

United States:	Hewlett-Packard Company Test and Measurement Call Center PO Box 4026 Englewood, CO 80155-4026 (800) 452 4844 (toll-free in US)
Canada:	Hewlett-Packard Canada Ltd. 5150 Spectrum Way Mississauga, Ontario L4W 5G1 (905) 206 4725
Europe:	Hewlett-Packard European Marketing Centre Postbox 999 1180 AZ Amstelveen The Netherlands (31 20) 547 9900
Japan:	Hewlett-Packard Ltd. Measurement Assistance Center 9-1, Takakura-Cho, Hachioji-Shi Tokyo 192, Japan (81) 426 56 7832 (81) 426 56 7840 (FAX)
Latin America:	Hewlett-Packard Latin American Region Headquarters 5200 Blue Lagoon Drive, 9th Floor Miami, Florida 33126, U.S.A. (305) 267 4245, (305) 267-4220 (305) 267 4288 (FAX)
Australia/New Zealand:	Hewlett-Packard Australia Ltd. 31-41 Joseph Street Blackburn, Victoria 3130 Australia 1 800 629 485 (Australia) 0800 738 378 (New Zealand) (61 3) 9210 5489 (FAX)
Asia-Pacific:	Hewlett-Packard Asia Pacific Ltd. 17-21/F Shell Tower, Times Square 1 Matheson Street, Causeway Bay Hong Kong (852) 2599 7777 (852) 2506 9285 (FAX)

Safety and Regulatory Information

Review this product and related documentation to familiarize yourself with safety markings and instructions before you operate the instrument. This product has been designed and tested in accordance with international standards.

WARNING

The **WARNING** notice denotes a hazard. It calls attention to a procedure, practice, or the like, that, if not correctly performed or adhered to, could result in personal injury. Do not proceed beyond a **WARNING** notice until the indicated conditions are fully understood and met.

CAUTION

The **CAUTION** notice denotes a hazard. It calls attention to an operating procedure, practice, or the like, which, if not correctly performed or adhered to, could result in damage to the product or loss of important data. Do not proceed beyond a **CAUTION** notice until the indicated conditions are fully understood and met.

Instrument Markings



When you see this symbol on your instrument, you should refer to the instrument's instruction manual for important information.



This symbol indicates hazardous voltages.



The laser radiation symbol is marked on products that have a laser output.



This symbol indicates that the instrument requires alternating current (ac) input.



The CE mark is a registered trademark of the European Community. If it is accompanied by a year, it indicates the year the design was proven.



The CSA mark is a registered trademark of the Canadian Standards Association.

1SM1-A

This text indicates that the instrument is an Industrial Scientific and Medical Group 1 Class A product (CISPER 11, Clause 4).



This symbol indicates that the power line switch is ON.



This symbol indicates that the power line switch is OFF or in STANDBY position.

Safety Earth Ground



This is a Safety Class I product (provided with a protective earthing terminal). An uninterruptible safety earth ground must be provided from the main power source to the product input wiring terminals, power cord, or supplied power cord set. Whenever it is likely that the protection has been impaired, the product must be made inoperative and secured against any unintended operation.

Before Applying Power

Verify that the product is configured to match the available main power source as described in the input power configuration instructions in this manual. If this product is to be powered by auto-transformer, make sure the common terminal is connected to the neutral (grounded) side of the ac power supply.

Typeface Conventions

Not all of the following conventions may appear within this manual, however, refer to this listing whenever you encounter one of the special font characters.

- | | |
|---------------------------|---|
| <i>Italics</i> | <ul style="list-style-type: none">• Used to emphasize important information:
Use this software <i>only</i> with the HP 8517B Test Set.• Used for the title of a publication:
Refer to the <i>HP 8517B S-Parameter Test Set Manual</i>• Used to indicate a variable:
Type <code>LOAD BIN filename</code>. |
| Instrument Display | <ul style="list-style-type: none">• Used to show on-screen prompts and messages that you will see on the display of an instrument:
The HP 8517B will display the message <code>CAL1 SAVED</code>. |
| Keycap | <ul style="list-style-type: none">• Used for labeled keys on the front panel of an instrument or on a computer keyboard:
Press <code>[Return]</code>. |
| Softkey | <ul style="list-style-type: none">• Used for simulated keys that appear on an instrument display:
Press <code>{Prior Menu}</code>. |
| User Entry | <ul style="list-style-type: none">• Used to indicate text that you will enter using the computer keyboard; text shown in this typeface must be typed <i>exactly</i> as printed:
Type <code>LOAD PARMFILE</code>• Used for examples of programming code:
<code>#endif // ifndef NO_CLASS</code> |
| <i>Path Name</i> | <ul style="list-style-type: none">• Used for a subdirectory name or file path:
Edit the file <code>usr/local/bin/sample.txt</code> |
| Computer Display | <ul style="list-style-type: none">• Used to show messages, prompts, and window labels that appear on a computer monitor:
The Edit Parameters window will appear on the screen.• Used for menus, lists, dialog boxes, and button boxes on a computer monitor from which you make selections using the mouse or keyboard:
Double-click EXIT to quit the program. |

Contents

Notice	ii
Restricted Rights Legend	ii
What You'll Find in This Manual.....	iii
HP 8517B S-Parameter Test Set	iii
Warranty	iv
Certification	iv
Warranty	iv
Assistance	v
Service and Support	vi
Safety and Regulatory Information	vii
Safety Earth Ground	viii
Before Applying Power	viii
Typeface Conventions	ix

1. Getting Started

How to Use This Manual	1-1
Test Set Description	1-2
<i>Figure 1-1. Standard HP 8517B Test Set Block Diagram</i>	1-2
<i>Figure 1-2. Option 004, HP 8517B Test Set Block Diagram</i>	1-3
<i>Figure 1-3. Option 007, HP 8517B Test Set Block Diagram</i>	1-3
HP 8517B Test Set Options	1-4
<i>Table 1-1. HP 8517B Options and Descriptions</i>	1-4
Verifying Test Set Operation	1-5
<i>Table 1-2. Test Set Operation Verification</i>	1-5
Checking System Operation	1-5
Checking Specifications	1-5
Troubleshooting the Test Set	1-5
Maintaining Measurement Accuracy	1-6
Instruments Supported by This Manual	1-7
<i>Figure 1-4. Instrument Serial-Number Label Example</i>	1-7
Instrument Firmware Compatibility	1-8
<i>Table 1-3. Source Firmware Revision Compatibility Matrix</i>	1-8
Service and Support Options Available	1-9
<i>Table 1-4. Service and Support Options</i>	1-9
Accessories	1-10
Recommended Test Equipment	1-12
<i>Table 1-6. Recommended Test Equipment</i>	1-12
Operating and Safety Precautions	1-13
<i>Table 1-7. Maximum Input Power Levels</i>	1-13
Safety Precautions	1-13

2. Installation	
Initial Inspection	2-2
Operating Environment	2-2
Storing the Test Set	2-2
Accessories Supplied	2-2
<i>Figure 2-1. Accessories Supplied with the HP 8517B Test Set</i>	2-3
<i>Table 2-1. Accessories in Figure 2-1</i>	2-3
Installing the Test Set Into a System Rack	2-4
Installing the Test Set on a Bench	2-4
<i>Figure 2-2. Recommended Static-Free Workstation Configuration</i>	2-4
Configuring the Test Set in a System	2-5
<i>Figure 2-3. Configuring an HP 8517B Test Set in a System</i>	2-5
Connecting the System Cables	2-6
<i>Table 2-2. Connection Instructions and Connector Descriptions</i>	2-6
Connect System Power	2-6
and Control Cables	2-6
Signal Path Connections	2-6
Test Port Connectors	2-6
Anti-Rotation Clamp	2-6
Replacing O-Rings in Anti-Rotation Clamps	2-6
Packaging the Test Set	2-7
3. Operating the HP 8517B Test Set	
Front-Panel Features	3-1
<i>Figure 3-1. Front-Panel Features of the HP 8517B Test Set</i>	3-1
<i>Table 3-1. Front-Panel Description</i>	3-1
Rear-Panel Features	3-2
<i>Figure 3-2. Rear-Panel Features of the HP 8517B Test Set</i>	3-2
<i>Table 3-2. Rear-Panel Descriptions</i>	3-2
Controlling Multiple Test Sets	3-3
<i>Figure 3-3. RF and IF Switching with Two Test Sets</i>	3-4
<i>Table 3-3. RF and IF Switch Settings in Figure 3-3, Above</i>	3-4
Multiple Test-Set Connections	3-5
Initialization at Power-Up	3-5
Selecting a Test Set	3-5
<i>Table 3-4. Selecting a Test Set When Multiple Units are Configured</i>	3-6
Test Set IF Switching	3-6
Test Set Addressing	3-6
RF Switch Driver Control	3-6
<i>Figure 3-4. RF and IF Switching with Four Test Sets</i>	3-7
<i>Table 3-5. Coaxial Switch Settings for Figure 3-4, Above</i>	3-7
Measurement Calibration	3-8
Measuring High-Power Devices with Option 004	3-9
Changing Signal Path States After System Calibration	3-10
Changing the Test Port Attenuators	3-10
Storing Trace Memories	3-11
Viewing Normalized Parameters	3-11

Making Operational Checks	3-13
Performance Verification	3-14
Using Anti-Rotation Clamps	3-15
Attach the first clamp	3-15
<i>Figure 3-5. Using a Torque Wrench Correctly</i>	3-16
Positioning the thumb-screw	3-16
<i>Figure 3-6. Visually Aligning Clamp and Nut Flats</i>	3-17
Positioning the connector	3-17
<i>Figure 3-7. Mating the Clamp and Nut Flats</i>	3-17
Aligning the thumb-screw	3-18
<i>Figure 3-8. Aligning the Thumbscrew With the Counter-Sink Hole</i>	3-18
Attaching the second clamp	3-18
4. Specifications	
Mechanical Specifications	4-1
Supplemental Characteristics	4-1
<i>Table 4-1. HP 8510/HP 8517B Mechanical Specifications</i>	4-1
<i>Table 4-2. HP 8510/HP 8517B Supplemental Characteristics</i>	4-1
5. Troubleshooting the Test Set	
Theory of Operation	5-2
<i>Figure 5-1. Standard HP 8517B RF Block Diagram</i>	5-2
The RF Source Power	5-2
The Reference Signal Path	5-3
The Test Signal Path	5-3
The S_{11} and S_{21} Measurements	5-3
The Sampler Control Switching	5-3
The LO Signal Control	5-4
Troubleshooting Sequence	5-5
<i>Figure 5-2. Troubleshooting Flowchart</i>	5-5
Equipment Needed But Not Supplied	5-6
<i>Table 5-1. Equipment Required, But Not Supplied</i>	5-6
Troubleshooting Procedures	5-7
<i>Table 5-2. Power Supply Voltages to A15</i>	5-7
<i>Table 5-3. Power Supply Voltages to A27</i>	5-7
<i>Figure 5-3. Power Supply Fuses and Test Points</i>	5-8
HP-IB Address Switch	5-8
<i>Figure 5-4. Instrument HP-IB Switch Setting</i>	5-9
Fuse Location	5-9
<i>Figure 5-5. Fuse and Voltage Cam Location</i>	5-9
<i>Figure 5-6. The ACTIVE LED Location</i>	5-10
If the Self-Test Fails to Run Properly	5-10
<i>Figure 5-7. HP 8518B Test Set, A4 Board Assembly LEDs</i>	5-11
<i>Table 5-4. Instrument Self-Test Indicator State Definitions</i>	5-11
<i>Figure 5-8. Service Adapter Connections</i>	5-12
Using the Service Adapter	5-12
Service Adapter Conclusions	5-13
<i>Table 5-5. Results Observations</i>	5-13

Unratioed Power Test	5-14
<i>Figure 5-9. Diagram of IF Signal Path</i>	5-14
Isolating Signal Path Problems	5-14
Testing Signal Paths 1-4	5-14
Testing Paths 5 and 6	5-16
<i>Figure 5-10. RF Path 1 and Path 2, HP 8517B Standard Test Set</i> .	5-17
<i>Figure 5-11. RF Path 3 and Path 4, HP 8517B Standard Test Set</i> .	5-18
<i>Figure 5-12. RF Path 5 and Path 6, HP 8517B Standard Test Set</i> .	5-19
<i>Figure 5-13. RF Path 1 through Path 4,</i> <i>HP 8517B Option 007 Test Set</i>	5-20
<i>Figure 5-14. RF Signal for Path 1 through Path 4,</i> <i>HP 8517B Option 007</i>	5-21
<i>Figure 5-15. RF Path 5 and Path 6, HP 8517B Option 007</i>	5-22
<i>Table 5-6. Test Results for Path 1 through Path 6</i>	5-23
Sample Diagnostics	5-23
<i>Table 5-7. Most Probable Failures</i> <i>(B indicates Bad; — indicates Good)</i>	5-23

6. HP 8517B Test Set Replacement Procedures

<i>Figure 6-1. ESD-Safe Workstation Configuration</i>	6-2
Performance Tests	6-2
Adjustments	6-2
Equipment Needed But Not Supplied	6-3
<i>Table 6-1. Replacement-Procedure Tools Needed</i>	6-3
<i>Figure 6-2. HP 8517B Major Assembly Location Diagram</i>	6-4
Assembly Replacement Procedures	6-5
Initial Precautions	6-5
Switch/Splitter Replacement	6-5
A18 Switch/Splitter Assembly	6-5
Frequency Converter Replacement	6-5
A14, A10 to A13 Frequency Converter Assembly	6-5
Regulator Board Replacement	6-6
A15 Regulator Board Assembly	6-6
Filter Capacitor Replacement	6-6
C1 to C4 Filter Capacitors	6-6
Test Port Connector Replacement	6-7
2.4 mm Test Port Connectors	6-7
<i>Figure 6-3. Diagram of 2.4 mm Test Port Connector</i>	6-7
Fan Assembly Replacement	6-8
B1 Fan Assembly	6-8
Power Transformer Replacement	6-8
T1 Power Transformer	6-8
<i>Figure 6-4. Wire Connections to FLI Line Module</i>	6-9
O-Ring Replacement	6-10
<i>Figure 6-5. Positioning the O-Ring Within the Clamp</i>	6-10
Front Panel and Interface Board Replacement	6-10
A1 Front Panel and Interface Board Assembly	6-10

Bias Tees Replacement	6-11
A7 and A9 Bias Tees	6-11
Test Port Coupler Replacement	6-11
A6 and A8 Test Port Couplers	6-11
Test Port Attenuator Replacement	6-11
A16 or A17 Port Attenuators	6-11
Input Amplifier Replacement	6-12
A22 Input Amplifier Assembly	6-12
Buffer Amplifier Replacement	6-12
A23 to A26 Buffer Amplifiers	6-12
Post Regulator Board Replacement	6-13
A27 Post Regulator Board Assembly	6-13

7. HP 8517B Replaceable Parts

Introduction	7-1
Rebuilt-Exchange Assemblies	7-1
Replaceable Parts List	7-1
Ordering Information	7-2
To Order Parts Fast!	7-2
<i>Table 7-1. Reference Designation Abbreviations</i>	7-2
<i>Table 7-2. Manufacturer Names and Addresses</i>	7-3
<i>Table 7-3. Standard Abbreviations</i>	7-4
<i>Table 7-4. Multipliers, Abbreviation and Description</i>	7-10
<i>Figure 7-1. Power Cable and Plug Part Numbers</i>	7-11
<i>Table 7-5. Instrument Fuses</i>	7-12
<i>Figure 7-2. The Low Cost Rebuilt-Exchange Procedure</i>	7-13
<i>Table 7-6. Major Assembly Reference Designator and Parts Information</i>	7-14
<i>Figure 7-3. Major Assembly Locations in the Standard</i>	
HP 8517B Test Set	7-15
<i>Table 7-7. Semi-Rigid Cable Assemblies in the Standard</i>	
HP 8517B Test Set	7-16
<i>Table 7-8. Flexible Cable Assemblies in the Standard</i>	
HP 8517B Test Set	7-17
<i>Table 7-9. Miscellaneous Parts, Front Panel HP 8517B Test Set</i>	7-19
<i>Table 7-10. Test Port Connector Assembly Components</i>	7-20
<i>Table 7-11. Miscellaneous Parts, Rear Panel HP 8517B Test Set</i>	7-21
<i>Figure 7-4. Detailed Views of Hardware Stack-Ups</i>	7-23
<i>Table 7-12. Miscellaneous Parts, Top Internal View</i>	7-24
<i>Table 7-13. Miscellaneous Parts, Motherboard</i>	7-25
<i>Table 7-14. Parts Unique to HP 8517B Option 001 Test Set</i>	7-27
<i>Table 7-15. Parts Unique to HP 8417B Option 002 Test Set</i>	7-29
<i>Table 7-16. Parts Unique to HP 8517B Option 004 Test Set</i>	7-30
<i>Table 7-17. Parts Unique to HP 8517B Option 007 Test Set</i>	7-31
<i>Table 7-18. Parts Unique to Option 002 “plus” Option 007</i>	7-33
<i>Table 7-19. Parts Unique to Option 004 “plus” Option 007</i>	7-34
<i>Table 7-20. Instrument Chassis Replaceable Parts</i>	7-35

1

Getting Started

This is the operating and service manual for the HP 8517B S-parameter test set. It is to be used in conjunction with the *HP 8510C Network Analyzer Operating and Service Manual*. Together, these manuals provide information needed to configure the system and make measurements.

How to Use This Manual

-
- | | |
|---------|--|
| Step 1. | Review Chapter 1, "Getting Started" and Chapter 2, "Installation" of this manual to learn about: <ul style="list-style-type: none">• Using this test set• Using options of the test set• Preparing the site for operation• Understanding safety considerations• Unpacking the instrument and checking it for shipment damages• Configuring the HP 8517B test set with the HP 8510C Network Analyzer |
| Step 2. | Insert the contents of this manual into the HP 8510C Test Sets and Accessories binder behind the tab labeled "Test Sets." |
| Step 3. | Review the <i>Connector Care Quick Reference Card</i> (HP part number 08510-90360) supplied with the HP 8510C manuals set.
Refer to the calibration kit documentation for complete information about care, cleaning, gaging, and connecting precision devices. Knowledge and application of proper connector care is essential to achieving good connections and maintaining maximum performance quality with your precision calibration devices. |
| Step 4. | Read Chapter 3, "Operation," to learn about test set front- and rear-panel features. This chapter also has information about controlling multiple test sets, measuring high power devices, using the anti-rotation clamps on the cables, and connecting devices to the test set. |
| Step 5. | Refer to Chapters 4 through 7 for reference information about specifications, troubleshooting, replacement procedures, and replacement parts information. |
-

Test Set Description

The HP 8517B test set configured with an HP 8510B/C network analyzer and an HP 8360 series source, creates a system capable of making S-parameter measurements from 45 MHz to 50 GHz. The system is particularly suited for making two-port device measurements. You can measure all four S-parameters without physically reversing the DUT (device under test).

The system is also designed for making measurements on non-reciprocal devices or components like transistors, amplifiers or isolators where S_{12} measurements are required.

Two directional couplers are used for signal separation. The configuration is illustrated in the following figures:

- Figure 1-1, "Standard HP 8517B Test Set Block Diagram"
- Figure 1-2, "Option 004, HP 8517B Test Set Block Diagram"
- Figure 1-3, "Option 007, HP 8517B Test Set Block Diagram"

For active-device measurements, two bias tees apply external DC bias to both test port center conductors.

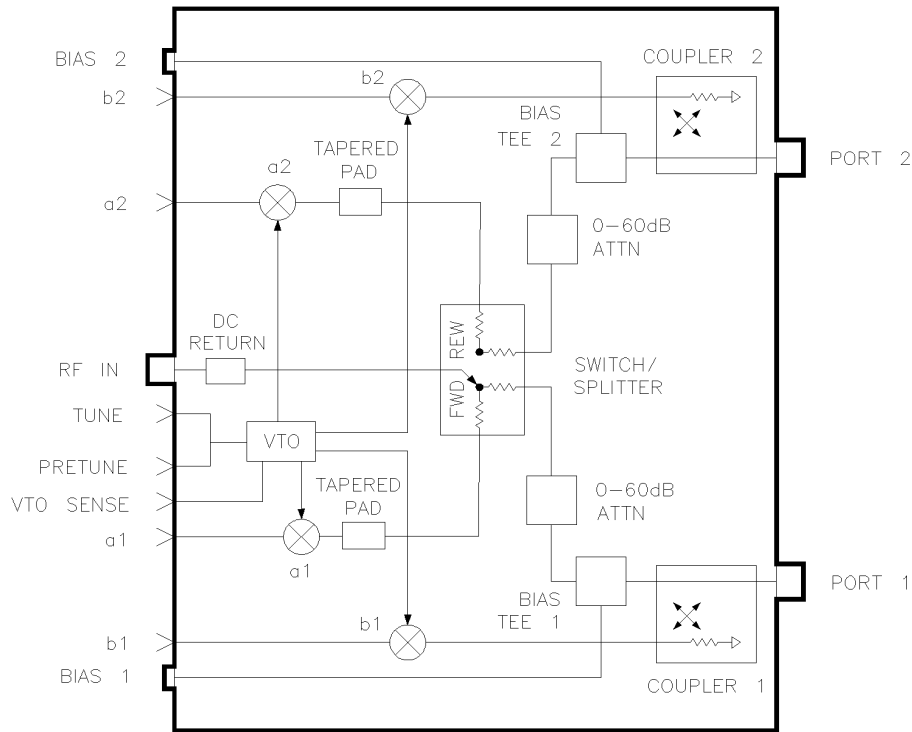

stbid_d

Figure 1-1 Standard HP 8517B Test Set Block Diagram

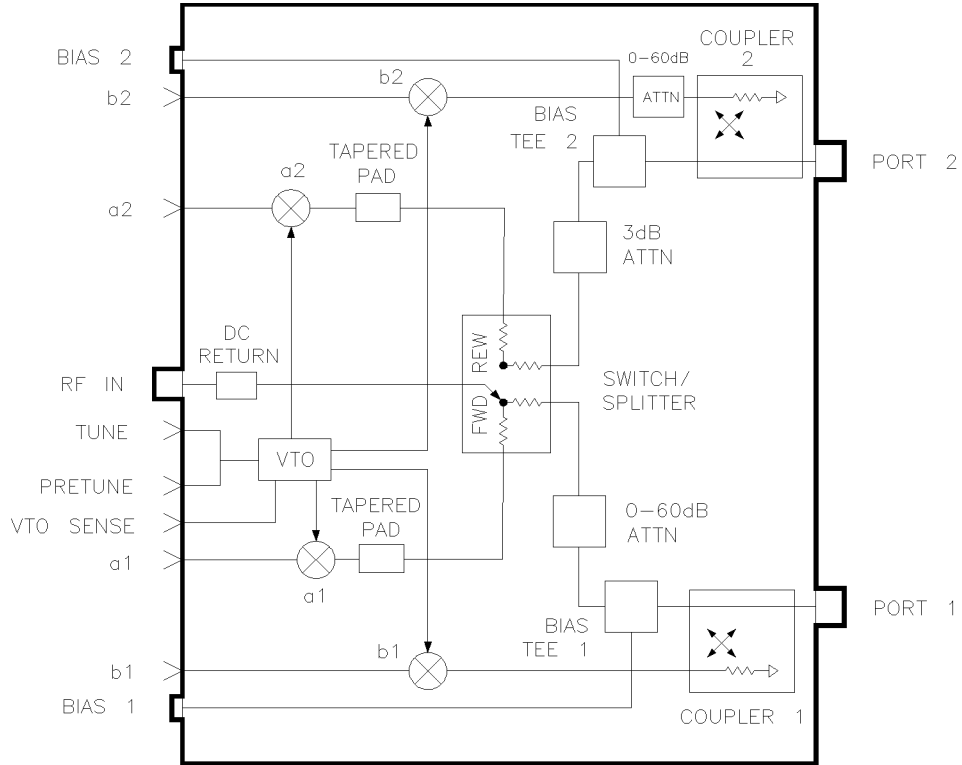

x004bld

Figure 1-2 Option 004, HP 8517B Test Set Block Diagram

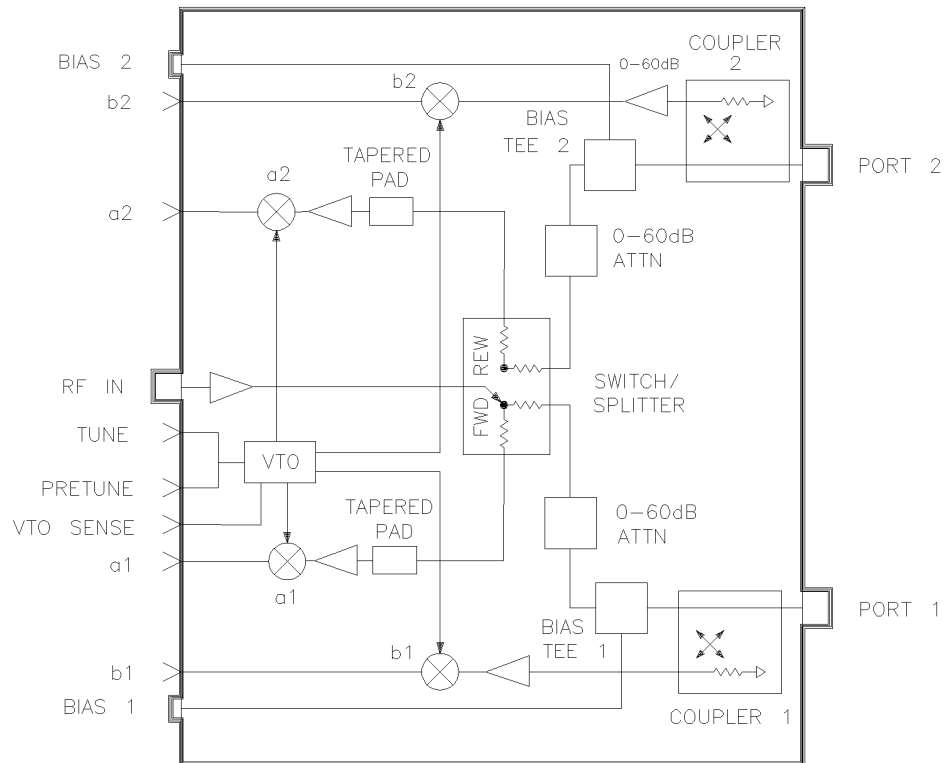

007bld

Figure 1-3 Option 007, HP 8517B Test Set Block Diagram

HP 8517B Test Set Options

Options for the HP 8517B test set are described in Table 1-1, below.

Table 1-1 *HP 8517B Options and Descriptions*

Options	HP 8517B Test Set Option Description
Option 001	Adds IF switching capability for up to four test set connections to the HP 8510C Network Analyzer. The test set used is selected from the network analyzer. Refer to "Controlling Multiple Test Sets" in Chapter 3, "Operation" of this manual for more information.
Option 002	Deletes the programmable attenuators and bias tees. <i>Note:</i> If bias is required but attenuation is not, the bias can be applied externally by using an HP 11612B bias tee.
Option 004	Moves Port 2 attenuator in front of the b2 sampler, allowing devices with output power up to 30 dBm (1 W) to be measured. Adds a 3 dB attenuator which protects the switch splitter from high power into Port 2.
Option 007	Adds five amplifiers, two 10 dB attenuators, two 6 dB attenuators, and two tapered attenuators. These components increase the available power and dynamic range of the test set.
Option 908	Supplies the hardware required for rack mounting the test set when its handles are removed. Refer to Chapter 2, "Installation" for more information.
Option 910	Adds a duplicate copy of this manual to the shipment.
Option 913	Supplies the hardware required for rack mounting the test set with its handles attached. Refer to Chapter 2, "Installation" for more information.
Option 002 "plus" 007	Removes the bias tee, and retains the high dynamic range capability in the test set.
Option 004 "plus" 007	Adds high-dynamic range and high power measurement capability to Port 2.

Verifying Test Set Operation

The test set is designed to operate with an HP 8510C network analyzer. You can verify its operation by:

Table 1-2 *Test Set Operation Verification*

Checking System Operation	Perform a system calibration as described in the <i>HP 8510C Operating and Programming Manual</i> . A successful calibration indicates that the system, and therefore the test set, are operating properly.
Checking Specifications	Specifications for the test set, and the system, can be determined by running the specification and performance verification software described in the <i>HP 8510C On-Site Service Manual</i> , Chapter 8, "Specification and Performance Verification". Additional mechanical specifications and supplemental characteristics are in Chapter 4, "Specifications" of this manual.
Troubleshooting the Test Set	To troubleshoot the test set, refer to the <i>HP 8510C On-Site Service Manual</i> . Use the information in that manual to determine if the test set is at fault. If the test set is at fault, refer to Chapter 5, "Troubleshooting the Test Set" in this manual to isolate the trouble.

Maintaining Measurement Accuracy

Precision measurements rely on a precision calibration of the network analyzer. As a general rule, the shorter the time lapse between a calibration and a device measurement, the more precise the measurement results will be (within the limitations of your system).

Hewlett-Packard recommends calibrating your system every few hours, or at least re-verifying your system's calibration this frequently. Doing so helps retain measurement precision.

The frequency of calibrations is determined by both the location of the system and the ambient temperature stability in its operating area.

Instruments Supported by This Manual

A serial number label is attached to the rear panel of the test set. There are two parts to the serial number: a prefix, and a suffix. See Figure 1-4, and read the following descriptions:

- The prefix includes the first four digits of the serial number, plus the letter. The contents of this manual apply directly to test sets with the same serial number prefix as the one(s) on the title page.
- The suffix includes the last five digits of the serial number, which is sequential and unique to each test set. You will need this part of the number to report test-set problems to an HP sales and service engineer.

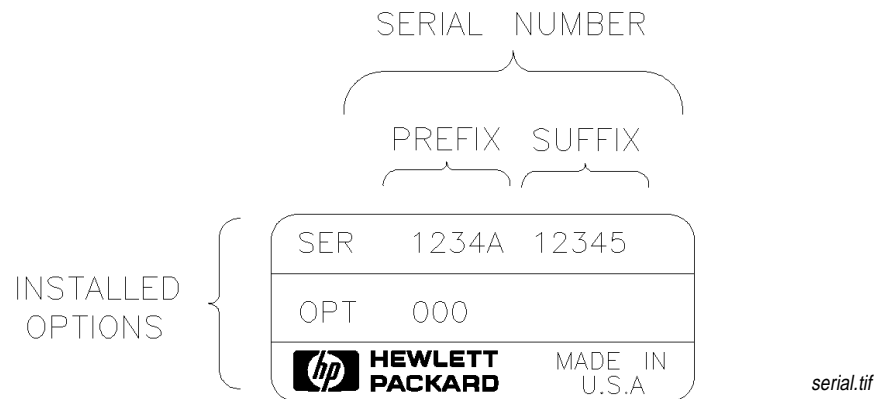

Figure 1-4 Instrument Serial-Number Label Example

Instrument Firmware Compatibility

To use the HP 8517B test set at frequencies up to 50 GHz, use an HP 83650B or HP 83651B source.

If your network analyzer or source do not meet the required frequency ranges for your measurement needs, you need to upgrade your system.

Please contact an HP Sales and Service representative for information. These offices are listed in “Service and Support” on page vi at the front of this manual

Table 1-3 Source Firmware Revision Compatibility Matrix

Instrument Model Number and Name	Compatible With Model:	Firmware Revision	Compatible With HP 8340 Series Sources?	Compatible With HP 8350 Series Sources?
HP 8517B Test Set	HP 8510B Network Analyzer HP 8510C Network Analyzer	B.06.00 and higher C.06.00 and higher	Yes, up to the higher frequency limits.	Yes, up to the higher frequency limits.
HP 8517B, Option 007 Test Set	HP 8510C Network Analyzer	7.0 or higher, only	Yes, up to the higher frequency limits.	No, not compatible

Service and Support Options Available

A variety of service and support products are available for coverage of repair, calibration, and verification issues. Contact your HP sales and service engineer for details. Their office addresses and phone numbers are listed in the front of this document.

The purchase of an HP 8517B includes a one year on-site service warranty. In the event of failure, Hewlett-Packard provides service for the system.

NOTE

System installation is not included.

Table 1-4 *Service and Support Options*

Option Number	Option Description
Option W30	Adds a three year customer return-repair coverage warranty to the instrument. Customers may return the instrument to HP within that three year period for repair.
Option W31	Adds a three year on-site repair coverage warranty for next-day on-site repair of the instrument. Customers may return the instrument to HP within that three year period for repair and get next-day service on their instrument.
Option 1BN	Adds to the instrument a MIL-STD 45662A Certificate of Calibration. <i>This option must be ordered when the instrument order is placed.</i>
Option 1BP	Adds to the instrument a MIL-STD 45662A Certificate of Calibration and the corresponding calibration data. <i>This option must be ordered when the instrument order is placed.</i>
Option UK6	Adds a certificate of calibration (rather than the MIL-STD certificate) and the corresponding calibration data to the instrument. <i>This option must be ordered when the instrument order is placed.</i>

Accessories

The accessories supplied with the test set, including part numbers, are listed in “Accessories Supplied” in this section and in the “Replaceable Parts List” of this manual.

Accessories Available

Table 1-5 describes accessories available for the HP 8517B test set. For additional HP 8510C system accessories information, refer to the HP 8510C manual set.

Table 1-5 HP 8517B Test Set Accessories Available

Accessory Type	Accessory Model Number	Contents or Description
Calibration Kit ¹	HP 85056A 2.4 mm Calibration Kit	Contains open and short circuits Fixed and sliding loads (2) 2.4 mm to 2.4 mm adapters 2.4 mm connector tools and gauges
Verification Kit ¹	HP 85057S 2.4 mm Verification Kit	Contains precision airline, mismatched airline, 20 dB and 40 dB attenuators
Cables	HP 85133C 2.4 mm Test Port Return Cable	Used when measuring a 2.4 mm-ported device connected directly to Port 1 of the test set. The test port return cable is connected between the device under test and Port 2.
	HP 85133D 2.4 mm Test Port Return Cable Set	Used when measuring a 2.4 mm-ported device connected between the cable ends.
	HP 85133E 2.4 mm Flexible Test Port Return Cable	Used when measuring a 2.4 mm-ported device connected directly to Port 1 of the test set. The test port return cable is connected between the device under test and Port 2.
	HP 85133F 2.4 mm Flexible Test Port Return Cable Set	Used when measuring a 2.4 mm-ported device connected between the cable ends.
	HP 85134D 3.5 mm Test Port Return Cable Set	Used when measuring a 3.5 mm device under test connected between the cable ends.
	HP 85134E 3.5 mm Flexible Test Port Return Cable	Used when measuring one end of a 3.5 mm device connected directly to an HP 85130F adapter at Port 1. The test-port return cable is connected between the device and Port 2.
	HP 85134F 3.5 mm Flexible Test Port Return Cable Set	Used when measuring a 3.5 mm device connected between the cable ends.
	HP 85135C 7 mm Test Port Return Cable	Used when measuring one end of a 7 mm device connected directly to an HP 85130E adapter at Port 1. The test port return cable is connected between the device and Port 2.
Cables (Continued)	HP 85135D 7 mm Test Port Return Cable Set	Used when measuring a 7 mm device connected between the cable ends.

Table 1-5 HP 8517B Test Set Accessories Available (Continued)

Accessory Type	Accessory Model Number	Contents or Description
	HP 85135E 7 mm Flexible Test Port Return Cable	Used when measuring one end of a 7 mm device connected directly to an HP 85130E adapter at Port 1. The test port return cable is connected between the device and Port 2.
	HP 85135F 7 mm Flexible Test Port Return Cable Set	Used when measuring a 7 mm device connected between the cable ends.
Adapters	HP 85130E Special 2.4 mm to 7 mm Adapter Set	Used to convert special 2.4 mm test set ports into a 7 mm connector interface (m or f).
	HP 85130F Special 2.4 mm to 3.5 mm Adapter Set	Used to convert special 2.4 mm ports of the test set into a 3.5 mm connector interface (m or f).
	HP 85130G Special 2.4 mm to 2.4 mm Adapter Set	Used to convert special 2.4 mm ports of the test set into a standard 2.4 mm connector interface (m or f). These adapters function as "test port savers."
	HP 11904S 2.4 mm to K-2.9 mm ² Adapter Kit	Used to calibrate the test set using 2.4 mm devices, then to change the test ports to 2.92 mm and perform fully error corrected measurements. The kit contains (2) 2.4 mm to 2.92 mm (m) adapters and (2) 2.4 mm to 2.92 (f) adapters.
Test Fixture Kit	HP 85041A Transistor Test Fixture Kit (TTF)	A comprehensive measurement system for testing and characterizing stripline packaged microwave transistors. Although the fixture contains 7 mm connectors and its frequency limit is 18 GHz, the kit may be adapted for use with the test set. Use HP 85135C or HP 85135E cables with the HP 85130E adapter set. Please consult your HP Sales and Service representative for recommendations.

1. NIST traceable data and uncertainties are available.
2. The K-connector is developed and manufactured by the Wiltron Company (Morgan Hill, California).

NOTE

For more information about other 2.4 mm adapters, refer to the "2.4 mm Adapters and Calibration Accessories," Operating Note, (HP part number 11900-90003).

Recommended Test Equipment

Additional equipment and accessories required for use with the test set are listed in Table 1-6. The table lists which items are required to verify the performance of the test set and which are required to operate it. Other equipment may be substituted if their specifications meet or exceed those listed in the critical specifications column

Table 1-6 *Recommended Test Equipment*

Item	Critical Specifications	Recommended Model	Use
Network Analyzer	no substitute	HP 8510B or HP 8510C	O, P, T
Source	no substitute	HP 83651B	O, P, T
Controller	no substitute	HP 9000 Series 200 or 300 with 3 Mbyte RAM and HP BASIC 3.0 or higher or PCC-305 or PC-308 HP BASIC Controller with 3 Mbyte Basic Language Processor RAM	N/A
Disk Drive	is compatible with the controller	is compatible with the controller	P
Multimeter	range: 0 to 50 V	HP 3456A	T
Oscilloscope	50 MHz bandwidth	HP 1740A	T

O = Operation; P = Performance Test; T = Troubleshooting

Operating and Safety Precautions

CAUTION

ESD Sensitive Assemblies

Test set assemblies are very sensitive to damage from electrostatic discharge. They may or may not continue to function if subjected to electrostatic discharge. Their reliability, however, will be impaired. Handle the instrument devices at static-safe work stations, only.

Operating Precautions

Observe the following normal precautions when handling and operating the test set:

- Do *not* exceed the input power levels listed below:

Table 1-7 Maximum Input Power Levels

Power Level	Test Port
+17 dBm	Port 1
+17 dBm	Port 2
+30 dBm ¹	Port 2 (Option 004, or Option 004 "plus" 007)

1. This is the maximum input power allowed with HP 8517B Option 004, or Option 004 "plus" Option 007, when the attenuator is set to ≥ 0 dB. Without attenuation, the maximum input power allowed is +17 dBm.

- Do not exceed +15 dBm into the test set with the source RF input.
- Never apply a dc voltage to the source RF input of the test set.
- Do not torque any connection at the test port connectors to more than 90 N-cm (8 in-lb). The wrench supplied with your accessory kit is calibrated for 90 N-cm (8 in-lb) torque.
- Do not torque any connection to more than 90 N-cm (8 in-lb) at the source RF input or on the back of your test set.

Safety Precautions

The voltages inside this test set warrant normal caution for operator safety. Nevertheless, service should be performed by qualified personnel, only. Service strategy, troubleshooting procedures, replaceable parts, and other information about the test set are provided in this manual or the *HP 8510C On-Site Service Manual*.

Getting Started
Operating and Safety Precautions

2

Installation

This chapter contains installation information. Topics include initial inspection, environmental considerations, test set location when using it with the HP 8510C network analyzer, and making connections to the test set.

Refer to “Installation” in the *HP 8510C On-Site Service Manual* for complete system connection and turn-on instructions.

Refer to “Packaging the Test Set” for information about shipping the instrument.

Initial Inspection

Inspect the shipping container and cushioning materials for damage. If there is damage, keep the container until you have checked the contents for completeness.

If shipping materials are damaged, complete the performance tests outlined in the *HP 8510C On-Site Service Manual*. If the test set fails the performance tests, or is damaged or defective, keep the shipping materials. Notify both the carrier and the nearest Hewlett-Packard Sales and Service Office (listed in “Service and Support” at the front of this manual).

The office can arrange for repair or replacement of the test set without waiting for the claim settlement.

Operating Environment

For the HP 8517B to operate within specifications, the ambient temperature must remain between 0° C and +55° C. Keep relative humidity to less than 95% (at 40° C dry bulb temperature, maximum). The instrument can be operated at altitudes up to 4,500 meters (15,000 feet).

Storing the Test Set

Acceptable storage temperatures range from -40° C to +75° C, with relative humidity 90% at +65° C (maximum dry bulb temperature) and at altitudes up to 15,240 meters (50,000 feet).

Accessories Supplied

Figure 2-1 illustrates accessories supplied with the test set. If you did not receive one of these accessories with the test set, notify your nearest HP Sales and Service Office so that the missing parts can be sent to you.

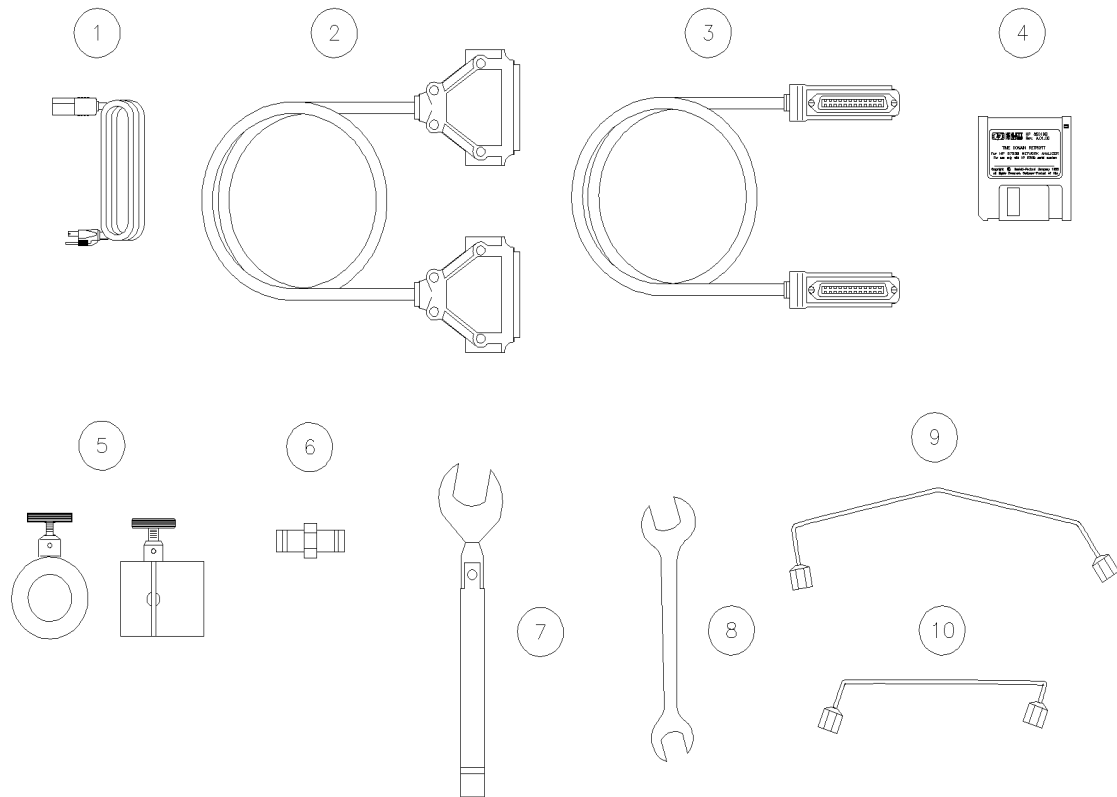

access_d

Figure 2-1 Accessories Supplied with the HP 8517B Test Set

Table 2-1 Accessories in Figure 2-1

(1) Power Cord U.S.A. only	(6) Female 2.4 mm to Female 2.4 mm Adapter
(2) Test Set Interconnect Cable	(7) 20 mm, 98 N-cm (8 in-lb) Torque Wrench
(3) HP-IB Cable	(8) 1/2" x 9/16" Open End Wrench
(4) Specification and Performance Verification Software	(9) RF Source Cable, Bench-top Configuration
(5) Anti-rotation Clamps	(10) RF Source Cable, Rack Configuration

CAUTION

Assemblies in the test set are extremely sensitive to damage by static electricity. They may or may not continue to function if subjected to an electrostatic discharge. Their reliability, however, will be impaired.

CAUTION

Always use an anti-static wrist strap when calibrating or verifying the test set or while using the test set to measure devices. Never touch test port center conductors. Use a wrist strap when connecting the extended center conductor of a sliding load termination.

Installing the Test Set Into a System Rack

The HP 85043C system rack is the recommended model to use. To rack-mount the test set into a system configured with the HP 8510C, refer to the “Installation” chapter of the *HP 8510C On-Site Service Manual* and to the HP 85043C System Rack Manual.

Installing the Test Set on a Bench

When installing the test set for use on a bench, place it on a grounded anti-static work surface to reduce the chance of ESD damage. The antistatic surface should extend far enough in front of the test set to provide effective protection for the test ports and cable ends. See Figure 2-2.

A grounding receptacle is provided on the test set as an alternate grounding point for your anti-static wrist-strap.

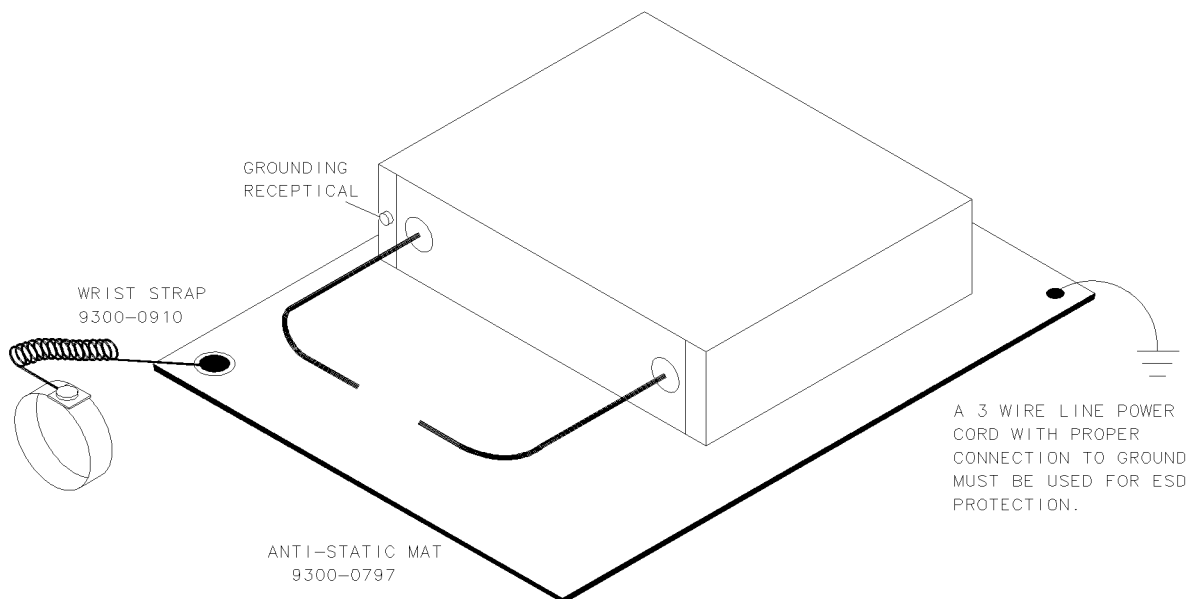

nostatic_d

Figure 2-2 Recommended Static-Free Workstation Configuration

Configuring the Test Set in a System

Figure 2-3 illustrates the cable connections for installing an HP 8517B in a system. Refer to the information that follows to install the test set.

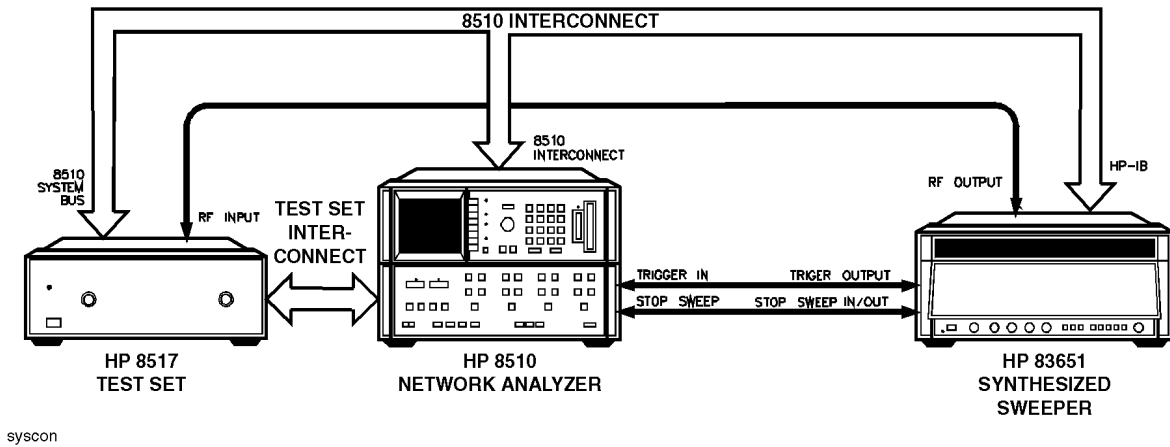

Figure 2-3 Configuring an HP 8517B Test Set in a System

Connecting the System Cables

Table 2-2 *Connection Instructions and Connector Descriptions*

Connect System Power and Control Cables	<p>Check the test-set line module (see item (1) in Chapter 3, Figure 3-2 of this manual). It must be set for the correct voltage in your region. Refer to Chapter 5, "Troubleshooting" of this manual for information about changing the voltage selection or replacing the line fuse.</p> <ul style="list-style-type: none">• After setting or confirming the line-voltage module, connect the test set power cord to an electrical outlet.• Attach the HP 8517B IF-interconnect cable from J11 TEST SET INTERCONNECT (on the test set's rear panel) to J1 TEST SET INTERCONNECT on the rear panel of the HP 85102 IF detector.• Attach the system bus cable from HP 8517B J12 HP 8510 SYSTEM BUS connector to HP 8510C INTERCONNECT on the HP 85101 display/processor. <p>The test set IF interconnect cable and the system bus cable transmit control signals between the test set and the network analyzer.</p>
Signal Path Connections	<p>The IF interconnect cable transmits IF signals from the test set to the HP 85102 IF detector.</p> <ul style="list-style-type: none">• Attach one end of the 2.4 mm RF cable (item 9 or 10, Figure 2-1) to the RF output on the rear panel of the HP 83651 Synthesized Sweeper.• Attach the other end of the RF cable to the RF input on the HP 8517B Test Set.
Test Port Connectors	<p>Port 1 and Port 2 are male, NMD-2.4 mm connectors, and mate to female 2.4 mm connectors.</p>
Anti-Rotation Clamps	<p>Use the anti-rotation clamps (item 5, Figure 2-1) to stabilize the test port or RF cable at the connection, or to stabilize an adapter at the connection.</p> <ul style="list-style-type: none">• Connect test port cables or adapters to the test ports.• Torque the connections to 90 N-cm (8 in lb).• Loosen the anti-rotation clamp thumb screw enough to slip the clamp over the cable and up to the front panel. The clamp end with the flats should come to rest on the flats of the test port shoulder.• Finger-tighten the thumb screws to prevent further loosening or tightening of the test port/RF cable connection. Refer to Chapter 3, "Operation" of this manual for additional information.

Replacing O-Rings in Anti-Rotation Clamps

The anti-rotation clamp's internal O-ring is a field-replaceable part. There is no need to disassemble the anti-rotation clamp.

When the O-ring no longer holds the RF cable securely, replace it by following the instructions in Chapter 6, "Replacement Procedures."

Packaging the Test Set

To repackage the test set, use its original factory packaging.

Refer to the test set using its complete model and serial numbers in any correspondence to an HP Sales and Service Office.

Containers and materials identical to those used in the original shipment by the factory are available through Hewlett-Packard Sales and Service Offices. However, commercially available, comparable packaging materials may be used, also.

1. Wrap the test set in heavy paper or anti-static plastic.
2. If you are shipping the test set to an HP Sales or Service office, complete and attach a service tag (located in the HP 8510C manual set).
3. Use sufficient shock absorbing material on all sides of the test set to provide a thick, firm cushion and prevent movement.
4. Seal the shipping container securely and mark it "FRAGILE."

Installation
Packaging the Test Set

3

Operating the HP 8517B Test Set

This chapter contains illustrations and descriptions of the HP 8517B front- and rear-panel features. Information about operating multiple test sets (Option 001) is also provided.

Front-Panel Features

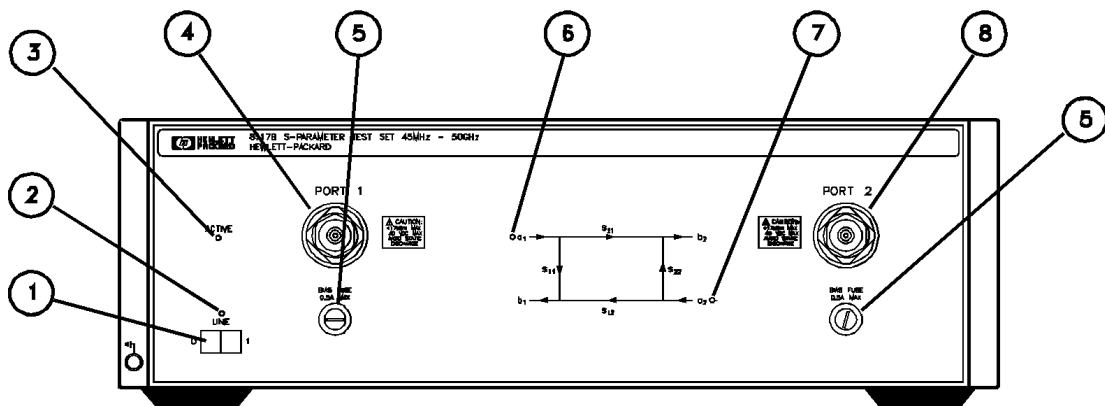

frntpan

Figure 3-1 Front-Panel Features of the HP 8517B Test Set

Table 3-1 Front-Panel Description

(1) Line Switch	This switch turns the test set on or off. When the side of the switch labeled "0" is depressed, the test set is OFF; when the side labeled "1" is depressed, the test set is ON.
(2) Line LED	This LED is lit when the test set line switch is ON and not lit when the test set line switch is OFF.
(3) Active LED	This LED lights about two seconds after power is turned on, following the successful conclusion of the self-test. If the test set is used with other test sets (Option 001) and is not addressed by the HP 8510C, then this light remains off.
(4) Port 1	This test port transmits RF energy from the source to the DUT and receives reflected or transmitted RF energy from the DUT. The reflected RF energy is coupled to a sampler within the instrument. Connections made to this input must be torqued to 90 N-cm (8 in-lb), and no more.
(5) Bias Fuse	The fuses that limit bias applied to Port 1 and Port 2 are located in these holders (see the instrument front panel or the replaceable parts list for the fuse values).

Table 3-1 Front-Panel Description (Continued)

(6) a1 LED	This LED indicates that the test set is internally switched to the S_{11} or S_{21} mode and source power is switched to Port 1.
(7) a2 LED	This LED indicates that the test set is internally switched to the S_{22} or S_{12} mode and source power is switched to Port 2.
(8) Port 2	This test port transmits RF energy from the source to the DUT and receives reflected or transmitted RF energy from the DUT.

Rear-Panel Features

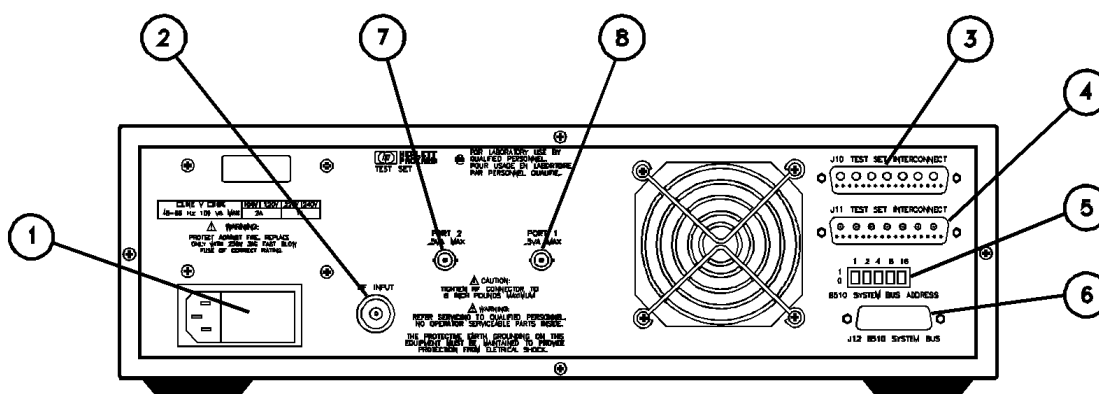

rearpan

Figure 3-2 Rear-Panel Features of the HP 8517B Test Set

Table 3-2 Rear-Panel Descriptions

(1) Line Module	Houses the line cord connector, line fuse and line voltage selector. Pull out the right side of the line module cover to replace or change the fuse or to change the voltage selection. Remove the voltage selector drum to rotate it to a different voltage setting. Recommended fuse values are printed on the rear panel.
(2) RF Input	A 2.4 mm connector that receives RF energy from the source. Connections made to this input must be torqued no more than 90 N-cm (8 in-lb).
(3) J10 Test Set Interconnect	Used only in test sets with Option 001. It allows connecting another test set to the option 001 test set. Up to four test sets can be serially connected to the analyzer. The HP 8510C system automatically selects the IF output from the chosen test set for processing and display. Refer to “Controlling Multiple Test Sets” in this chapter for more information.
(4) J11 Test Set Interconnect	Transmits the IF signal from the test set to the HP 85102 IF detector. It also transmits control signals bi-directionally.
(5) HP 8510 System Bus Address Switch	A five-pole binary-weighted switch sets the test-set’s system bus address. The binary weight of each pole is indicated on the rear panel. So are the On and Off positions. The default setting is decimal twenty (off-off-on-off-on, from left to right).

Table 3-2 Rear-Panel Descriptions (Continued)

(6) J12 8510 System Bus Connector	Used for HP-IB communications with the HP 85101 display/processor.
(7) Port 2 Bias	A female BNC connector used to supply bias through the center conductor of Port 2 to active devices under test.
(8) Port 1 Bias	A female BNC connector used to supply bias through the center conductor of Port 1 to active devices under test.

Controlling Multiple Test Sets

HP 851X Series, Option 001 test sets allow an HP 8510C to alternately control up to four test sets connected to it. For example:

- While a measurement is underway on test set number 1 (equipped with Option 001), a test device can be connected to test set number 2 (which does not need Option 001).
- When the measurement on test set number 1 is complete, the HP 8510C can then control test set number 2.

In a standard test set, the 20 MHz IF and control signals are applied directly to J11 TEST SET INTERCONNECT, which is attached to the HP 8510C.

Option 001 adds a set of IF switches, control switches, and the J10 TEST SET INTERCONNECT attachment. This configuration allows the selection of the 20 MHz test set IF signal.

As shown in Figure 3-3 on page 3-4, test set number 1 can:

- apply its IF signal to the HP 8510C, or it can
- switch to pass the IF signal from test set number 2, through J10 TEST SET INTERCONNECT, and into the HP 8510C.

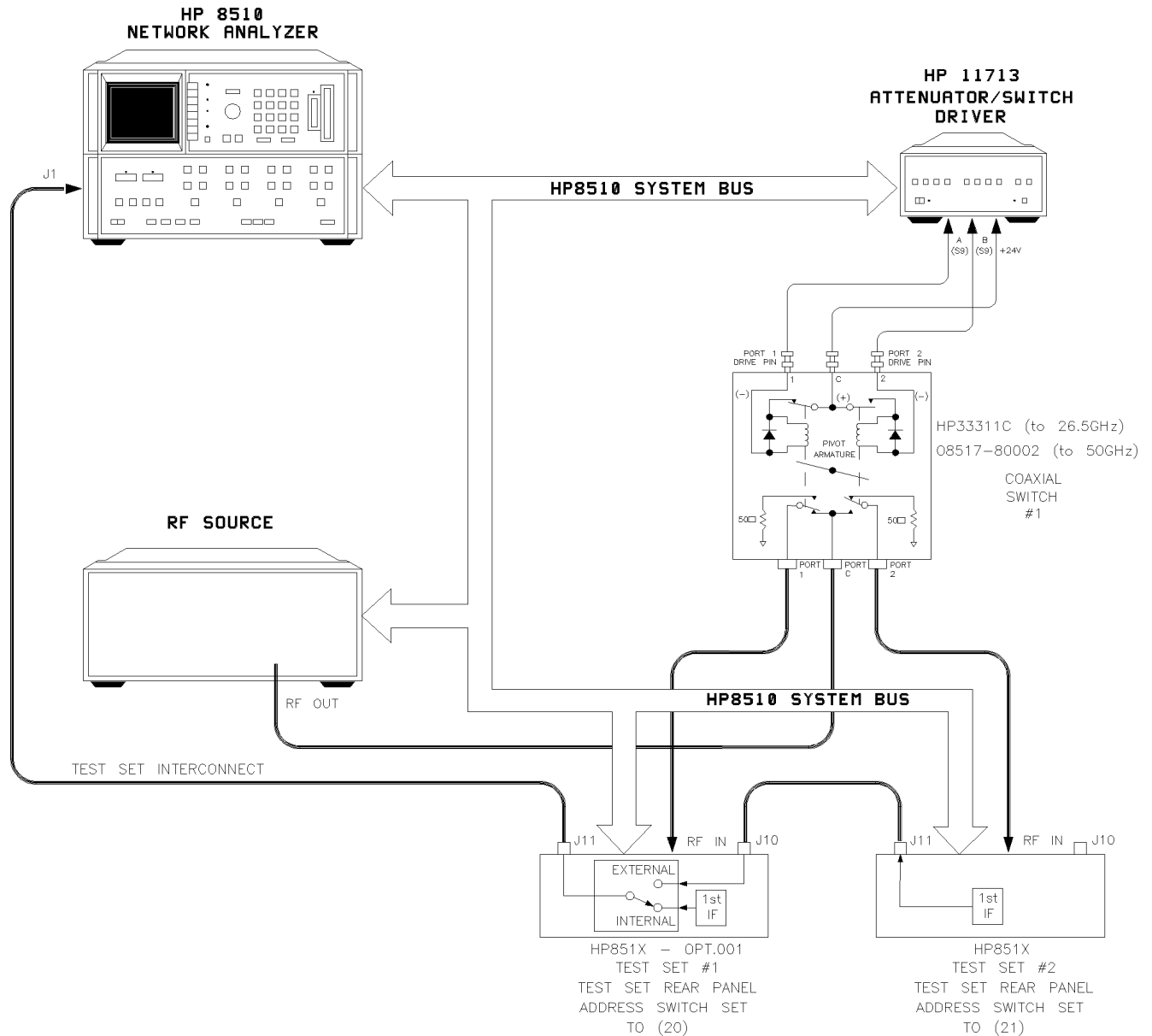

switching_d

Figure 3-3 RF and IF Switching with Two Test Sets

Table 3-3 RF and IF Switch Settings in Figure 3-3, Above

New ADDRESS of Test Set ^{1, 2}	Test Set Number Selected	Coaxial Switch Port Selected
20	Number 1	Port 1
21	Number 2	Port 2

1. Not all system connections are illustrated.
2. In dual source configurations, the second source may be multiplexed in a similar manner. If only one dual source test set is used, the second source may be connected directly to the appropriate test set.

Multiple Test-Set Connections

For dual test-set configurations, set each rear panel address switch on each test set to the address shown in Figure 3-3. Refer to Figure 3-4 on page 3-7 for the configuration of two or more test sets.

- Use the supplied test set interconnect cable to attach test set number 1, J11 to the network analyzer.
- Use the supplied test set interconnect cable to attach test set number 2, J11 to test set number 1, J10.

You may connect up to four test sets in a series if the total length of all test set interconnect cables does not exceed 13 meters (about 40 feet). The last test set connected in the chain does not require Option 001.

If the RF coaxial switch is not incorporated into the system, the RF input to the test set must be manually switched to the active test set.

Initialization at Power-Up

At power-up, configure the IF switches so that only *one* system test set is active. To verify which test set is active, use the following steps:

1. Verify that all system test set LEDs are lit.
2. View the network analyzer's test set address by pressing the INSTRUMENT STATE, [LOCAL] key, then press **{TEST SET}**. The HP-IB address of the test set is displayed on the screen.

The address displayed must match the address of the test set selected. If not, enter the correct address using the network analyzer's key pad.

3. If an unselected test set's LEDs are lit, deactivate it. Do this by entering its address, pressing [x1], then entering the address of the test set desired, followed by [x1].

Selecting a Test Set

To select another test set, follow the procedure in Table 3-4 on page 3-6 of this chapter.

Table 3-4 Selecting a Test Set When Multiple Units are Configured

Test Set IF Switching	<p>A test set is selected via the built-in capability of the analyzer to generate an addressed command to each test set. Each time you change the {HP-IB ADDRESS} {TEST SET} function (refer to LOCAL [MENU] in the <i>HP 8510C Operation and Service Manual</i>), the network analyzer does the following:</p> <ul style="list-style-type: none">• switches the IF signal of the previously addressed test set to external• switches the IF signal of the newly addressed test set to internal• sets the test set's front panel ACTIVE LED to indicate test-set status• applies the active test set's IF signals directly to J11 TEST SET INTERCONNECT• passes the inactive test set's IF signals at J10 through to J11 and on to the next test set or to the network analyzer
Test Set Addressing	<p>You can change the test set address via program control, or via the network analyzer front panel keys. You must also change the mechanical switches on the test-set's rear panel. Here's how:</p> <ol style="list-style-type: none">1. Change the test set address via the network analyzer keys;<ol style="list-style-type: none">a. On the analyzer's front panel, press the INSTRUMENT STATE [LOCAL] key, then press {TEST SET}. The test set's address appears on the display.b. Using the key pad, enter the desired address for the test set, then press [x1]. The new HP-IB address appears on the display.2. Change the test set address via the HP-IB command:<p>From the controller, enter the HP-IB ADDRESS; command, followed by the address value. Refer to the command reference for programming details.</p>3. Reset the mechanical switches on the test-set's rear panel. Set the switches to match the new HP-IB address displayed on the network analyzer screen.
RF Switch Driver Control	<p>When the {HP-IB ADDRESS} {TEST SET} function is changed, the network analyzer generates a code sequence. The code sequence is automatically issued across the HP 8510C system bus to the device at the ADDRESS of RF SWITCH .</p> <p>In the recommended configuration, the device is an HP 11713A attenuator/switch driver. The switch/driver in turn controls one or more coaxial switches. These switches, (shown in a Figure 3-3, and Figure 3-4) are used to choose which test set receives the RF output from the network analyzer source.</p> <p>The exact command issued depends upon the new value of the {HP-IB ADDRESS} {TEST SET} value, also shown in shown in a Figure 3-3 and Figure 3-4.</p>

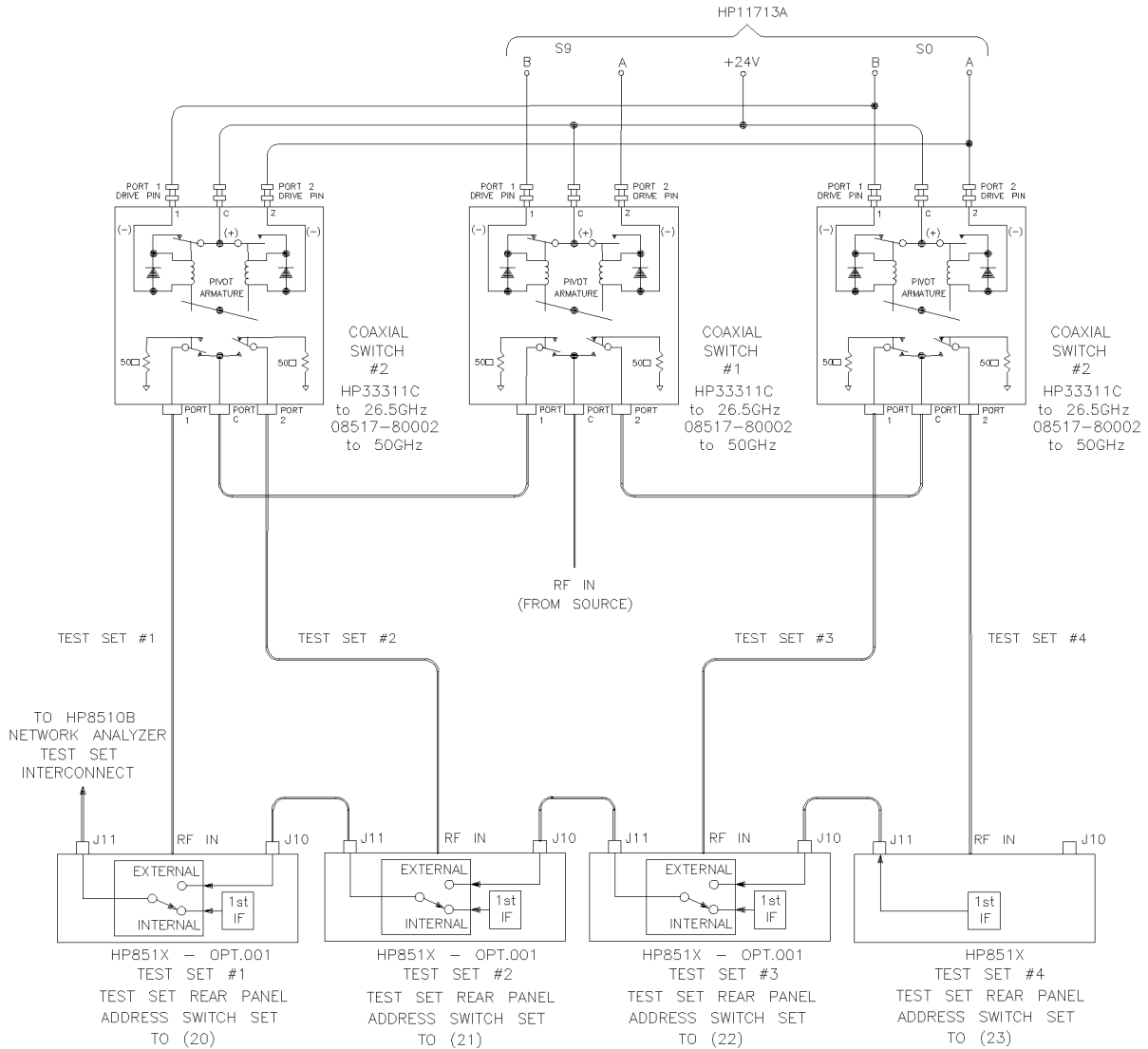

rfifsw_d

Figure 3-4 RF and IF Switching with Four Test Sets

Table 3-5 Coaxial Switch Settings for Figure 3-4, Above

New ADDRESS of Test Set ^{1, 2, 3}	Test Set Selected ^{1, 2, 3}	Coaxial Port Selected with Switch #1	Coaxial Port Selected with Switch #2
20	1	Port 1	Port 1
21	2	Port 1	Port 2
22	3	Port 2	Port 1
23	4	Port 2	Port 2

1. Not all system connections are shown.
2. In dual source configurations, the second source can be multiplexed in a similar manner.
3. If only one dual source test set is used, the second source can be directly connected to the appropriate test set.

Measurement Calibration

After selecting the active test set, complete the system calibration procedure as usual. When you select a different test set, make sure that you recall the cal set that applies to that test set.

NOTE

Since the cal-set limited instrument state does not include the number of the active test set, a cal set which does not apply to the current test set can be turned on without displaying the HP 8510C caution messages. However, this causes errors in the data displayed because incorrect error coefficients are applied to the measured data.

For convenience, store a hardware-state file and an instrument-state file for each combination of test set to cal set. You may also store your hardware state file on a tape or disk for future use.

To change the configuration, recall the appropriate hardware state file. The hardware state file:

- sets the address of test set
- issues the RF switch command, then
- recalls the appropriate instrument state file which
- recalls the cal set

Measuring High-Power Devices with Option 004

The HP 8517B, Option 004 test set enables devices with output power up to 30 dBm (1 watt) to be measured at Port 2, without adding external attenuators. Reverse dynamic range (S_{12}) degrades by approximately 3 dB.

When measuring devices having greater than +17 dBm output power, you must use the Port 2 step attenuator to decrease the power to ≤ 17 dBm.

The step attenuator has to be set during calibration for the value needed during device measurements. However, this setting may cause inadequate power level during calibration. Refer to “Changing Signal Path States After System Calibration” on page 3-10 for additional information.

Changing Signal Path States After System Calibration

Changing an internal attenuator or any external equipment after completing the calibration means the measurement results cannot be specified. You must use your own estimation of the potential error contribution due to the change.

For example, when the port attenuation is changed with correction ON, the message **CAUTION: CORRECTION MAY BE INVALID** displays. You must judge whether the error is tolerable in the particular application and how to compensate for the change.

The application question is: “Does increasing the signal level during calibration improve the calibration enough to risk a possible increase in error contributions when you change the setup?”

The only reason for changing an internal attenuator or external equipment between calibrations and measurements is to maximize the signal level under both conditions, thus minimizing uncertainty due to noise.

Many factors enter into a setup-change decision, for example:

- is it more accurate to calibrate at a low signal level without changing the setup, *or*
- is it more accurate to change the setup to optimize levels for both the calibration and measurement

Changing attenuators at Port 1 or Port 2 does not change the test set mismatch, directivity, or isolation characteristics severely. It does change the frequency response magnitude and phase, however. The difference between frequency response calibration and measurement can be normalized by using HP 8510C trace memories.

Changing the Test Port Attenuators

If only the attenuators at Port 1 or Port 2 are changed, use the following procedure to minimize errors:

1. Connect a short, or a thru, and set Port 1 and Port 2 attenuators for the best IF signal levels during calibration.
2. Perform the appropriate measurement calibration.
3. Connect the correct calibration standard, set Port 1 and Port 2 attenuators to the value required for operating the test device.

If you view the response of a short circuit, notice that:

- Changing Port 1 attenuator has negligible effect on S_{11} marker reading
- Changing Port 2 attenuator has negligible effect on S_{22} marker reading

This is due to the way the attenuators are paired. Both the reference and the test signal are changed by approximately equal amounts.

When viewing S_{21} or S_{12} , however, changing Port 1 or Port 2 attenuators offsets the marker reading by the difference value between Port 1 attenuator and Port 2 attenuator.

Storing Trace Memories

To compensate for the main frequency response effects due to changing the attenuators, use the HP 8510C trace memories and trace mathematics function, as explained below:

1. Connect the thru used for calibration and set the port attenuators to the value used for device measurement.
2. Recheck the user parameter levels, then press **PARAMETER [S₂₁]**.
3. Press **MENUS [DISPLAY]**, then **{DATA AND MEMORIES}**.

Press **DISPLAY: {DATA->MEMORY n}** to store the S_{21} trace in default trace memory 1. This trace represents the frequency response difference between the S_{21} signal path calibration and the measurement.

4. Press **PARAMETER [S₁₂]**, then press the following **DISPLAY:** menu keys:

{SELECT DEFAULTS}

{DEFAULT to MEMORY: 2}

{DATA->MEMORY 2}

The S_{12} trace is now stored in trace memory 2. This trace is the frequency response difference of the S_{12} signal path between calibration and measurement.

Viewing Normalized Parameters

Use the traces stored in memory 1 and memory 2 to normalize the corrected data to the new levels after the attenuation is changed. The next example uses normalization for S_{21} or S_{12} , only. To view the corrected parameters:

1. Press **MENUS [DISPLAY]**, then **{DATA AND MEMORIES}**
2. Press **PARAMETER [S₁₁]** and view the S_{11} measurement.
3. Press **PARAMETER [S₂₂]** and view the S_{22} measurement.
4. Press **PARAMETER [S₂₁]**, then the following **DISPLAY:** menu keys:

{SELECT DEFAULTS}

{DEFAULT to MEMORY: 1}

{MATH (/)}

5. View the S_{21} measurement. If the thru is connected, the transmission coefficient should be $1 \angle 0^\circ$.
6. Press PARAMETER [S₁₂], then press the following DISPLAY: menu keys:
{SELECT DEFAULTS}
{DEFAULT to MEMORY: 2}
7. Press PARAMETER [S₁₂] to view the S_{12} measurement. If the thru is connected, the transmission coefficient should be $1 \angle 0^\circ$.

Normalization is turned OFF for S_{11} and S_{22} measurements. Then the appropriate memory is selected and normalization is turned on to view S_{21} and S_{12} .

Since these are accurate, repeatable attenuators, this sequence may be effective in your application. If other parts of the test must be changed, especially components connected to the test ports, this procedure may require additional steps to adequately compensate for the changes.

Making Operational Checks

To check the operation of multiple test-set configurations, do the following:

1. Connect a device with a known response to test set number 1. Press the following HP 8510C front-panel keys:

INSTRUMENT STATE [LOCAL]

AUXILIARY MENUS [SYSTEM]

{HP-IB ADDRESSES}

{TEST SET}

2. When the message **TEST SET HP-IB ADDRESS** appears, enter **[20]**, the address of test set number 1, then press **[x1]**. The measurement trace from test-set number 1 should display.
3. Store the trace in memory by pressing the following keys:

MENU [DISPLAY]

{DATA AND MEMORIES}

{DATA --> MEMORY n}

DISPLAY: {DATA and MEMORY}

4. Next, enter the HP-IB address of test set number 2, followed by **[x1]**, then re-enter the address of test set number 1 followed by **[x1]**.
5. Repeat the above procedure for each of the other test sets in the system.

Observe any difference in the response between the stored trace and the results trace by switching back and forth between the test sets.

Any differences in data that you suspect are due to the IF switch (Option 001) or to RF switching, must be checked out. Refer to Chapter 5, "Troubleshooting the Test Set" in this manual.

Performance Verification

Standard system performance verification procedures verify the operation of an Option 001 test set used as test set number 1.

To verify the performance of a different test set in the configuration, enter its HP-IB address (as explained in “Making Operational Checks” on page 3-13) to select it, then continue with this procedure.

Refer to the *HP 8510C On-Site Service Manual* for its performance verification procedure.

Using Anti-Rotation Clamps

During the performance verification procedure, use anti-rotation clamps to secure RF connections at the test ports of each test set. While installed, each clamp stabilizes the connector on RF cable to the large nut on the test set's RF test port. If an adapter is used, the clamp stabilizes the adapter to the front panel RF port connector.

Without these clamps, the test port connections can loosen when a device under test is moved. As a result, the loosening can invalidate calibrations and measurements.

NOTE

These instructions refer to an installation using HP RF cables. However, the anti-rotation clamps may also be used with front panel adapters. Adapter installations are similar. There are two anti-rotation clamps included in the test set accessories box.

Attach the first clamp

Remove one anti-rotation clamp from the accessories box. Loosen its thumb-screw until it is nearly freed from the counter-sink socket in the clamp body. The clamp is shown as item (5) in Figure 2-1, "Accessories Supplied with the HP 8517B Test Set."

1. Gently push the clamp (round-hole end first) over and past the RF cable connector to be used.
2. Fit the rubber O-ring in the round end of the clamp over the connector.

NOTE

If the O-ring is not snug or is damaged, refer to the Chapter 6, "Replacement Procedures" for instructions about replacing the internal O-ring.

3. Wiggle the clamp to ease it over the connector.
4. Attach the cable to the test port and tighten it as specified in the cable manual.

NOTE

Do not twist the cable as you attach it to the test port.

Use the torque wrench supplied with your calibration kit to tighten the cable to 90 N-cm (8 in-lb). *Do not over-torque the connection.* See Figure 3-5.

CAUTION

Important! The test set RF connector becomes loosened easily. Hold the RF cable securely throughout the remainder of this procedure. Do not allow the cable to rotate.

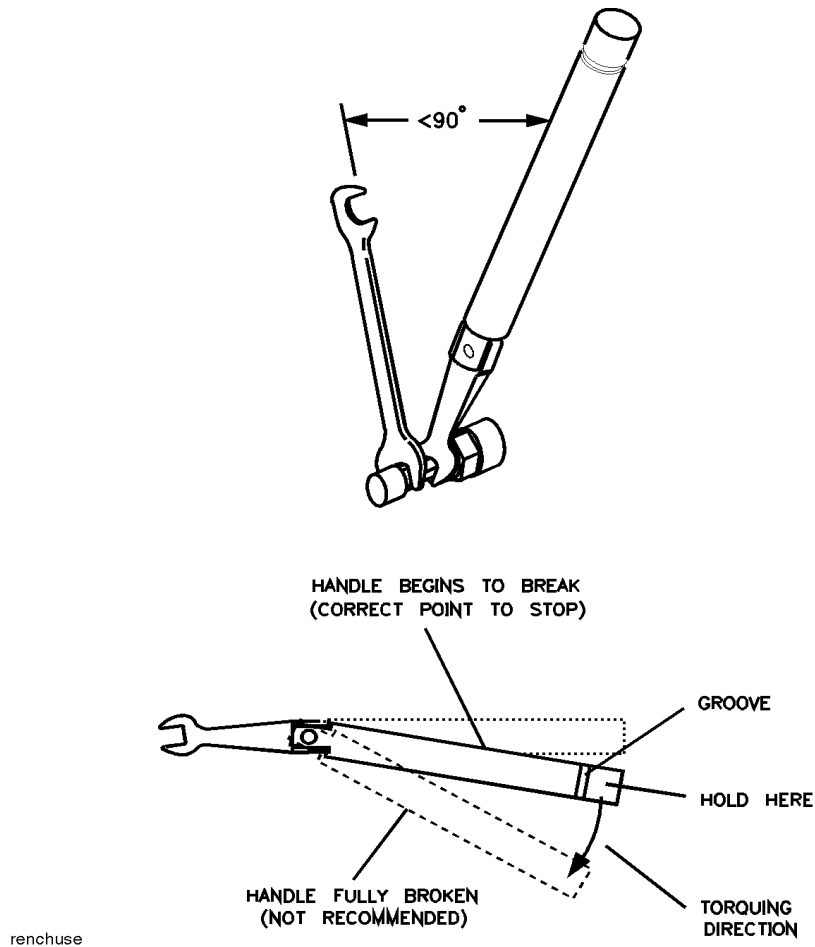

Figure 3-5 Using a Torque Wrench Correctly

Positioning the thumb-screw

See Figure 3-6. Position the clamp so the thumb-screw is positioned at the top of the clamp.

- Turn the clamp to visually align the clamp flats with the flats on the test port connector nut.
- This positioning minimizes rotating the connector in the procedure step.

NOTE

The flats may actually be in any orientation, with respect to the front panel.

MAKE SURE FLAT SURFACE
ON REAR OF CABLE CLAMP IS
PARALLEL WITH FLAT SURFACE
OF TEST SET CONNECTOR

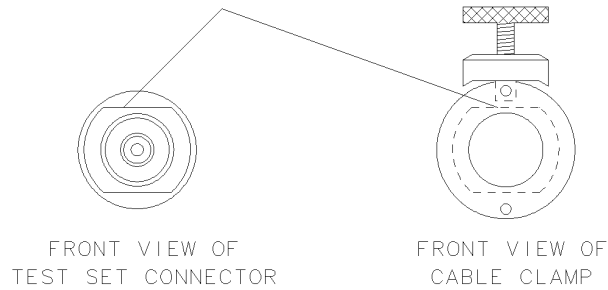

c l amp_d

Figure 3-6 Visually Aligning Clamp and Nut Flats

Positioning the connector

See Figure 3-7. Maneuver the clamp over the RF connector and onto the test port connector.

1. Hold the test cable with one hand. Use the other hand to press the clamp gently and steadily, as you wiggle it into position straight over the RF connector and onto the test port connector nut.

NOTE

Be sure to loosen the clamp when you are slipping it over the connector.

2. Fit the internal flats in the clamp over the flats on the test port connector nut.
3. Avoid rotating the clamp as you position it so the RF connection remains tight (remember it loosens easily).

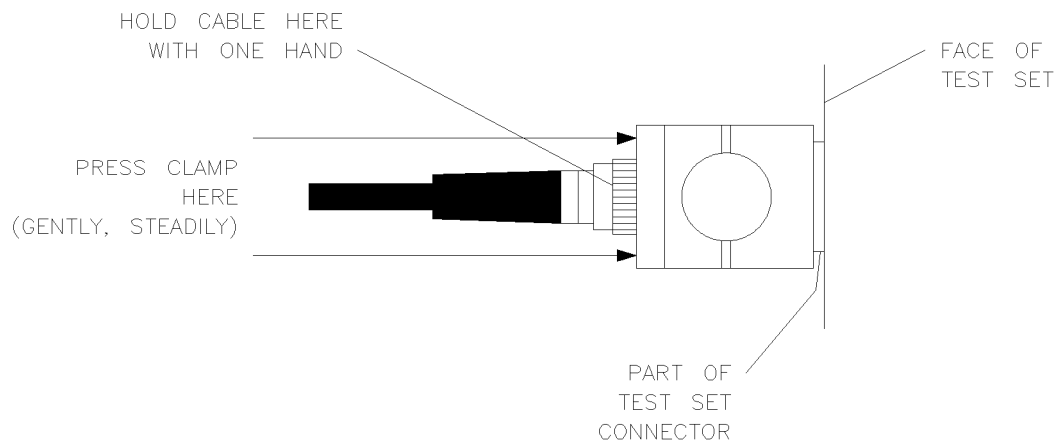

mating_d

Figure 3-7 Mating the Clamp and Nut Flats

Aligning the thumb-screw

See Figure 3-8. Ensure that the thumb-screw is aligned with the counter-sink hole on the clamp's body.

1. Push the clamp toward the test set front panel.
2. Finger-tighten the thumb-screw. The cable cannot be damaged if the thumb-screw is tightened too tightly.

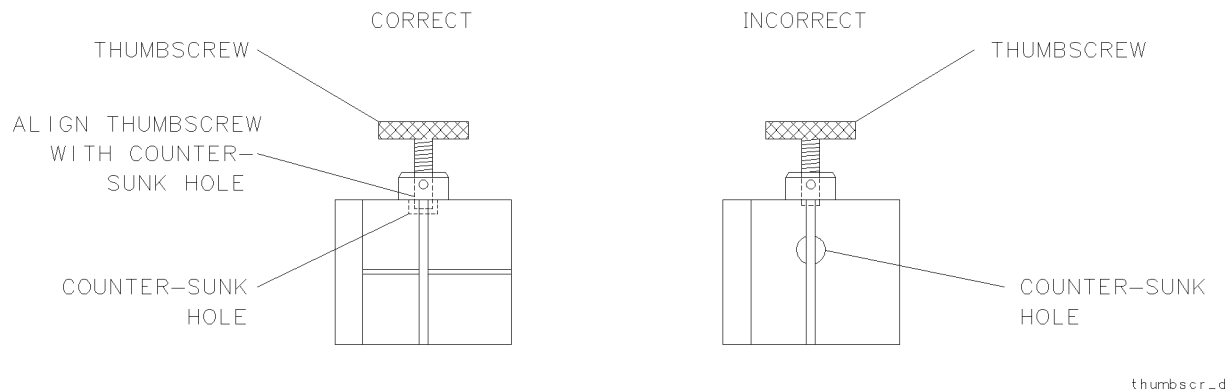

Figure 3-8 *Aligning the Thumbscrew With the Counter-Sink Hole*

Attaching the second clamp

To complete the anti-rotation clamp installation, repeat the steps above, beginning at step 1 to attach the second clamp.

4

Specifications

Specifications describe the warranted performance of the instrument. The electrical specifications of the test set when used with an HP 8510 network analyzer, are defined in the *HP 8510C On-Site Service Manual*.

Mechanical Specifications

Table 4-1 HP 8510/HP 8517B Mechanical Specifications

Test Port Description	Specification
Connector Type: Precision, rugged male test-port connector	2.4 mm ¹
Center Pin Recession ²	+0.00254 mm to +0.0178 mm +0.0001 inches to +0.007 inches

1. Precision rugged make test-port connector.

2. Refer to the calibration kit manual to learn about measuring the pin depth.

Supplemental Characteristics

Supplemental characteristics listed in Table 4-2 provide useful information by giving typical, but non-warranted, performance parameters.

Table 4-2 HP 8510/HP 8517B Supplemental Characteristics

Front Panel Test Ports	
Connector type	precision 2.4 mm, male
Connector torque	90 N-cm (8 in-lb), maximum
Impedance	50 Ω , nominal
Damage-input level	At Port 1 and Port 2: +17 dBm CW, RF At Port 2 with Option 004: 30 dBm CW (1 watt) CW, RF
DC bias	500 mA, 40 Vdc, maximum
Nominal source operating power level	-2 dBm to -20 dBm, with flatness correction off, depending on frequency
Nominal connector-nut size	20 mm

Table 4-2 HP 8510/HP 8517B Supplemental Characteristics (Continued)

Rear Panel RF Connectors	
Connector type	precision 2.4 mm female
Recommended connection torque	90 N-cm (8 in-lb), maximum for precision-2.4 mm hardware
Damage input level	15 dBm ¹
Nominal connector-nut size	8 mm
User 1 Power Levels for Reference Channel Phase Lock	
Minimum power level	-45 dBm
Maximum power level	-10 dBm to -20 dBm, depending on frequency
HP 8517B Power Requirements and Physical Characteristics	
Operating temperature range	0° C to 55° C
Input Power (AC)	110, 120, 220, or 240 Vac, ±10% Line frequency from 47 to 66 Hz
Dimensions	460 mm (High) × 133 mm (Wide) × 609 mm (Deep) (18.1 inches H × 5.25 inches W × 24 inches D)
Weight	15 kg (35 lb), net

1. This must be AC coupled.

5

Troubleshooting the Test Set

The troubleshooting strategy for the HP 8517B S-Parameter test set is a systematic sequence of procedures. The information may be used after system-level troubleshooting has identified the test set as the problem instrument.

Use the troubleshooting flowchart in Figure 5-2 to help isolate the faulty assembly. Notice procedure numbers within some of the flow diagram blocks. These are keyed to troubleshooting procedures. Perform the numbered procedure associated with each block as you progress through the chart.

Refer to the block diagrams, located at the end of this section, to help you understand the test set's operation.

Theory of Operation

RF paths for Port 1 and Port 2 are similar. This section discusses in detail the source power signal, as it is routed via the RF IN connector, through the test set, and to Port 1 for S_{11} and S_{21} measurements.

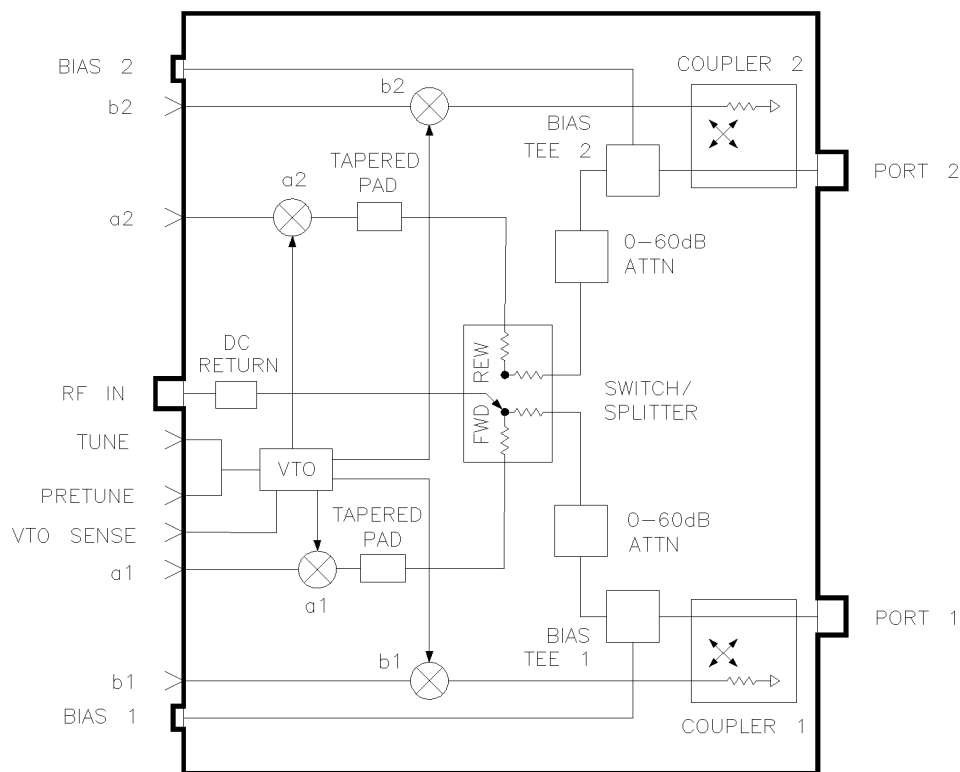

simpbd_d

Figure 5-1 Standard HP 8517B RF Block Diagram

The RF Source Power

- RF source power enters the test set through the rear panel. The RF power is applied to the switch/splitter (A18).
- At the switch/splitter, the power is attenuated by approximately 7 to 14 dB, depending upon frequency.
- The switch/splitter receives its control signals from the attenuator/switch driver board (A5).
- The switch part of the switch/splitter, which is a combination of two power splitters and a solid-state switch, selects the power splitter to use and, therefore, the test port to receive the RF power.
- LEDs on the front panel and on the attenuator/switch driver board (A5) indicate which test port is active.

The Reference Signal Path

- The reference signal is routed from the switch/splitter through the 20-7 dB tapered pad (AT1) to attenuate any VTO feed-through signals.
- The signal is then applied to A10, the a1 sampler assembly, where it is down-converted to a 20 MHz IF (intermediate frequency).
- Because the RF power is being routed to Port 1, the a1 IF signal is used to phase lock the network analyzer. Had the RF power been routed to Port 2, the a2 IF signal would have been used to phase lock the network analyzer.

The Test Signal Path

- The test signal is routed from the switch/splitter (A18) to the 60 dB programmable attenuator (A16) for Port 1.
- The signal may then be attenuated in 10 dB steps or passed through without attenuation to Port 1 bias tee (A7).
- A bias supply to provide dc voltage to Port 1 bias tee can be connected to J8 on the rear panel of the test set, also.
- The RF signal rides this dc level which is used to turn active devices on (bias ON) so their S-parameters can be measured.
- Beyond the bias tee, the test signal travels to the directional coupler (A6).
- At the coupler, the incident RF power is applied to the device under test.

The S_{11} and S_{21} Measurements

- The signal reflected from the DUT is separated from the signal incident to the DUT by the Port 1 coupler (A6).
- The reflected signal exits the coupler and is applied to b1 sampler (A12), then is down-converted to a 20 MHz IF signal.
- The S_{11} measurement is the ratio of the two IF signals from a1 and b1 samplers.
- The incident signal is transmitted through the DUT, through Port 2 coupler, then into b2 sampler (A13).
- The incident signal is down-converted to a 20 MHz IF so S_{21} can be measured. S_{21} is the ratio of the two IF signals from samplers a1 and b2.

The Sampler Control Switching

- The samplers may be turned on and off, depending upon the parameter being measured.
- Sampler switching is controlled by a microprocessor on the HP-IB board assembly (A4). The default condition (test set power ON and no HP-IB commands sent by the network analyzer) is for the test set to be active with the RF signal applied to Port 1.

Theory of Operation

- If the test set is equipped with Option 001 (multiple test set capability), its begin state is inactive. That is, rather than using the test set's internal IF, a switch is set in the test set to accept an IF from another test set.

The LO Signal Control

The LO, generated by A14 VTO/driver, is phase locked to the source so the desired VTO harmonic is 20 MHz greater than the source frequency.

The phase-locked loop includes:

- Portions of the test set, such as the VTO summing-amp board (A3), the VTO/driver (A14), and the a1 sampler assembly (A10), and
- The HP 8510C Network Analyzer

The VTO summing-amp board (A3) provides control voltages to tune the VTO to the correct LO frequency.

The VTO also has an output LENDRA (Low END of RAnge) which is routed via the test set interconnect cable, to the HP 85102.

The LENDRA provides an indication to the network analyzer about whether or not the VTO is operating within its normal frequency range.

If the VTO exceeds its normal frequency range, the network analyzer displays the running error message **VTO OVER RANGE**.

CAUTION

Electrostatic Discharge Sensitive (ESD) Assemblies

Assemblies you might handle in these troubleshooting procedures are extremely sensitive to damage from static electricity. They may or may not continue to function if they are subjected to electrostatic discharge. Their reliability, however, will be impaired.

Troubleshooting Sequence

Use this troubleshooting flowchart, along with the procedures in the following section, to help isolate faulty assemblies.

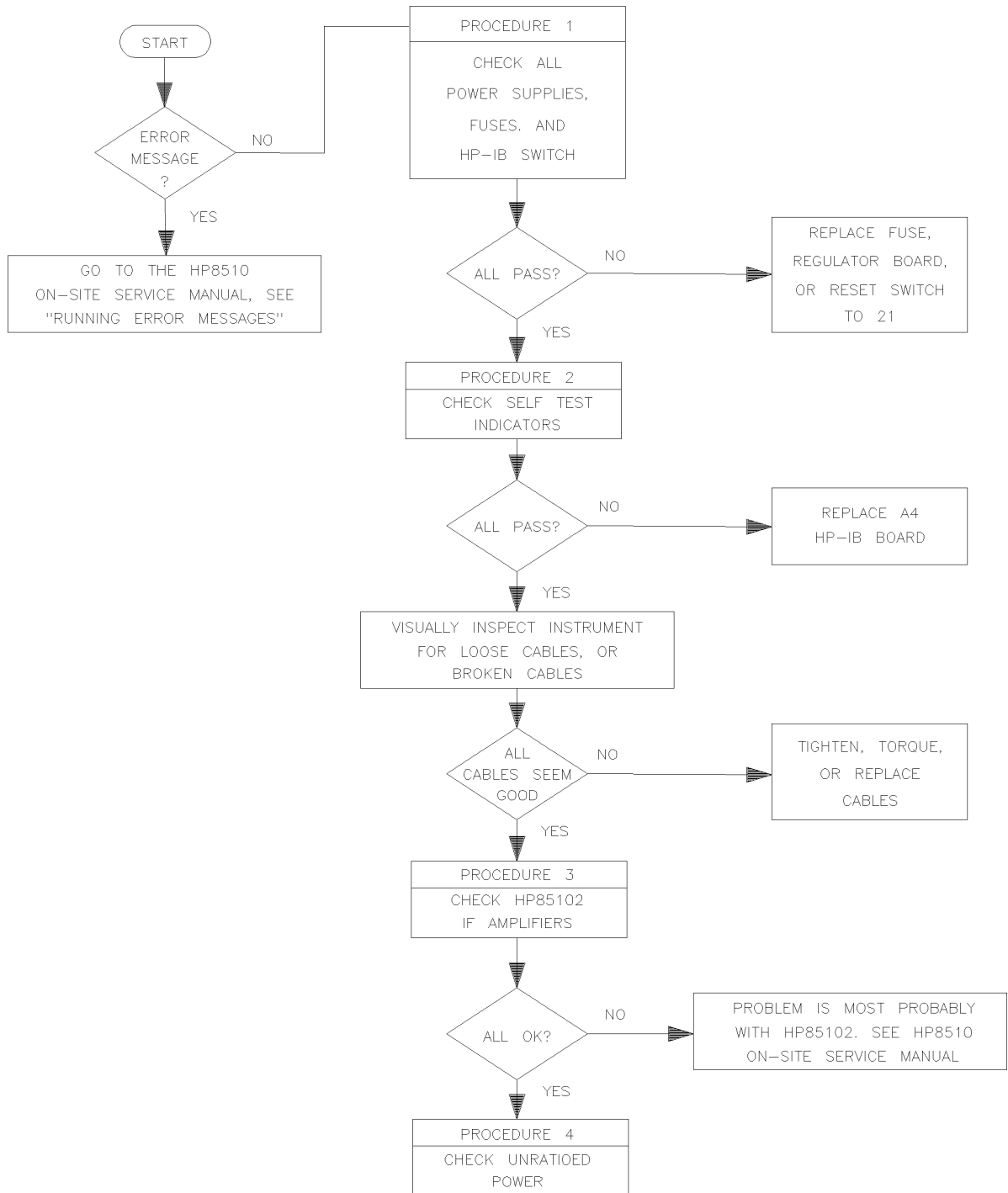

flowchrt

Figure 5-2 Troubleshooting Flowchart

Equipment Needed But Not Supplied

Gather the equipment listed in Table 5-1 to use for troubleshooting the test set (these items are not supplied with the instrument at shipment).

Table 5-1 Equipment Required, But Not Supplied

Equipment Type	HP Part Number
1-point, Pozidriv screwdriver	8710-0899
2-point, Pozidriv screwdriver	8710-0900
Service adapter	85105-60210
5/16-inch torque wrench	8710-1655
Oscilloscope	HP 1740A

Troubleshooting Procedures

The troubleshooting procedures in this chapter are listed below:

- “A15 Primary Regulator Board Assembly” on page 5-7
- “A27 Post-Regulator Board Assembly” on page 5-7
- “Self-Test Indicators” on page 5-9
- “HP 85102 IF Amplifier Test” on page 5-12
- “Unratioed Power Test” on page 5-14
- “HP 8517B, Option 007 Unratioed Power Test” on page 5-20
- “Finding the Faulty Assembly” on page 5-23

A15 Primary Regulator Board Assembly

Use a digital voltmeter to check the voltages and an oscilloscope to check for a maximum ripple level as listed in Table 5-2.

Table 5-2 Power Supply Voltages to A15

Nominal Voltage	Test Point	Voltage Range	Maximum Ripple Peak-to-Peak
+5.05 Vdc	A15TP1	+4.75 to +5.25	2 mv
-5.20 Vdc	A15TP2	-4.90 to -5.50	2 mv
+14.85 Vdc	A15TP3	+14.10 to +15.60	2 mv
-14.85 Vdc	A15TP6	-14.10 to -15.60	2 mv

A27 Post-Regulator Board Assembly

(Option 007, Only) Use a digital voltmeter to check the voltages and an oscilloscope to check for a maximum ripple level as listed in Table 5-3.

Table 5-3 Power Supply Voltages to A27

Nominal Voltage	Test Point	Voltage Range	Maximum Ripple Peak-to-Peak
+5.0 Vdc	A27TP1	+4.75 to +5.25	2 mv
-3.50 Vdc	A27TP2	-3.26 to -3.75	2 mv

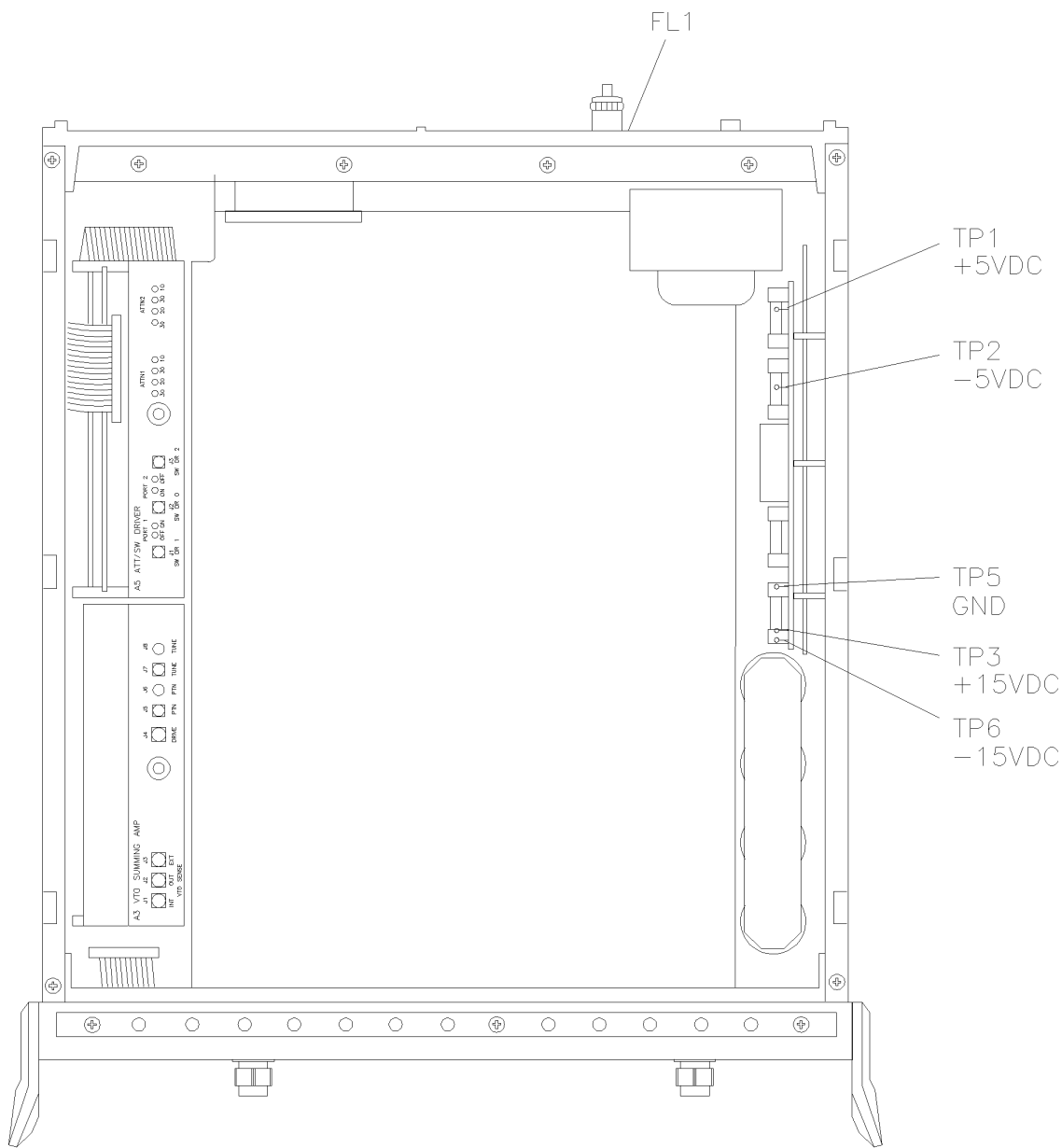

powersup

Figure 5-3 Power Supply Fuses and Test Points

HP-IB Address Switch

The HP-IB address switch is located on the rear-panel of the instrument. It is easy to access, but unnecessary to change unless the error message **SYSTEM BUS ADDRESS ERROR** appears on the system display.

To set the HP-IB address switch, position the switches as illustrated in Figure 5-4 (the LSB is on the left-hand side; the MSB is on the right-hand side). The default setting is decimal twenty, or binary 10100 as read from right-to-left (on, off, on, off, off). In the drawing, the dark-side is selected.

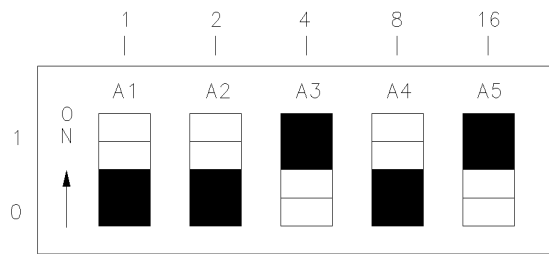

hpi bsw_d

Figure 5-4 Instrument HP-IB Switch Setting

Fuse Location

The fuse is located inside the line module at the rear panel of the test set. The value rating and part number of the fuse is listed in Chapter 7, “Replaceable Parts” of this manual. Review the information in Figure 5-5 to replace the line fuse or to set the voltage selector cam.

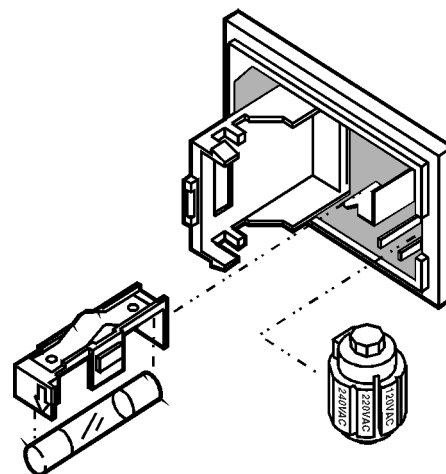

SRSB
 voltage1.cdr
 Rev 1.0

Caution!

Do not attempt to rotate the voltage selector cam while it is installed in the line module or NON-REPAIRABLE DAMAGE will result. The cam must be completely removed from the line module, rotated to the proper position, and reinstalled. Refer to the instructions below.

Replacement of Fuse

1. Pry open the line module cover door.
2. Pull out fuse carrier.
3. Insert fuse of proper rating.
4. Place carrier back into line module.

Selection of Operating Voltage

1. Pry open the line module cover door.
2. REMOVE CAM FROM THE LINE MODULE.
3. Rotate the cam to the desired voltage (when the line module cover door is closed, the selected voltage will be visible through a small window).
4. Insert the cam back into the line module.
5. Close the line module cover door.

Figure 5-5 Fuse and Voltage Cam Location

Self-Test Indicators

If the front-panel ACTIVE LED (shown in Figure 5-6) fails to light within five seconds after turning the power on, or if it lights immediately, the instrument has failed self-test.

To determine the portion of the self-test that failed, note which LEDs on A4 board assembly are turned on. Figure 5-7 shows the location of the LEDs. See Table 5-4 for the condition description of the LED status indicators.

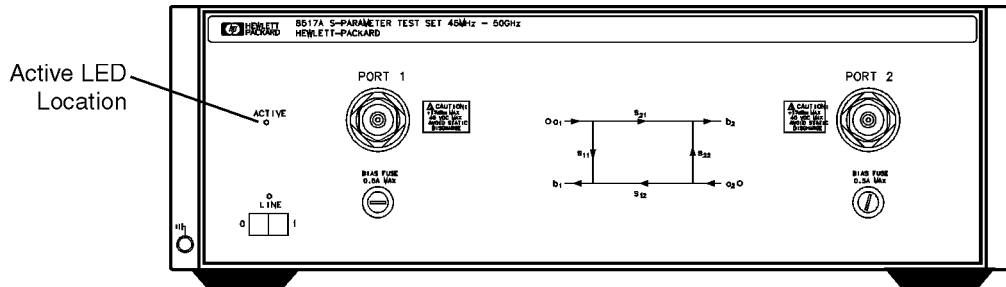

acted

Figure 5-6 The ACTIVE LED Location

If the Self-Test Fails to Run Properly

If the portion of memory holding the self-test program is faulty, the self-test will not run properly. If any of the following conditions occur, it indicates that the A4 HP-IB board is likely to be faulty.

- All LEDs flash briefly, then turn off
- All LEDs flash briefly and stay on
- The ACTIVE LED turns on too quickly after power on
- The ACTIVE LED does not turn on at all

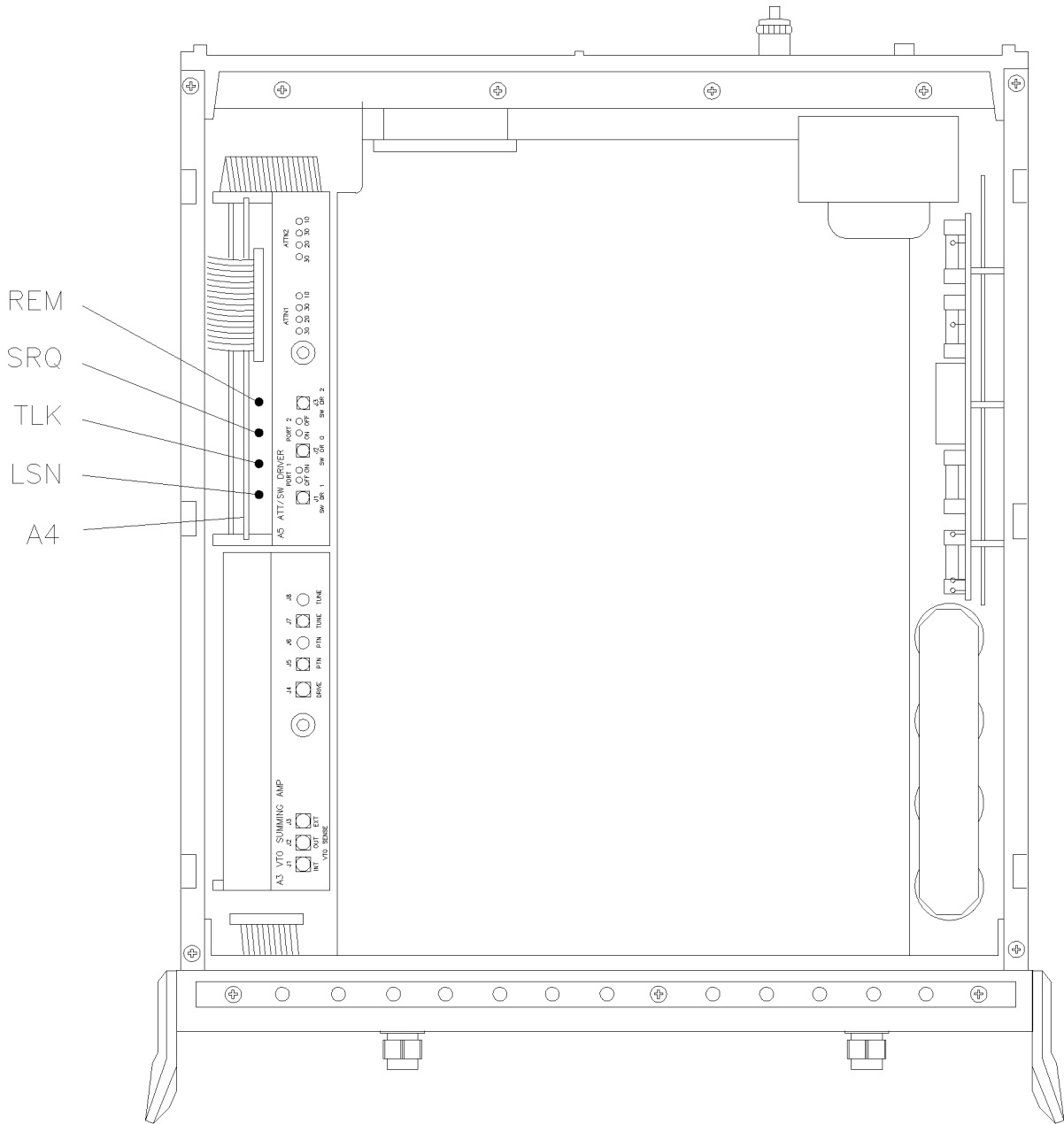

indicators

Figure 5-7 HP 8518B Test Set, A4 Board Assembly LEDs

Table 5-4 Instrument Self-Test Indicator State Definitions

Self-Test Indication	LSN	TLK	SRQ	REM	Time (Following Power-On)
PWON	ON	ON	ON	ON	0 to 0.5 seconds
Start ROM Test	OFF	ON	ON	ON	on briefly (a flash)

Table 5-4 Instrument Self-Test Indicator State Definitions

Self-Test Indication	LSN	TLK	SRQ	REM	Time (Following Power-On)
Pass ROM Test	OFF	OFF	ON	ON	0.5 to 0.2 seconds
Start RAM Test	OFF	OFF	OFF	ON	N/A
Pass RAM Test	OFF	OFF	OFF	OFF	after 2 seconds

HP 85102 IF Amplifier Test

The service adapter can substitute as a test set by returning the 20 MHz IF signal from the HP 85102 to the amplifier on the HP 85102. Doing this determines whether a fault is in the test set or is in the HP 85102.

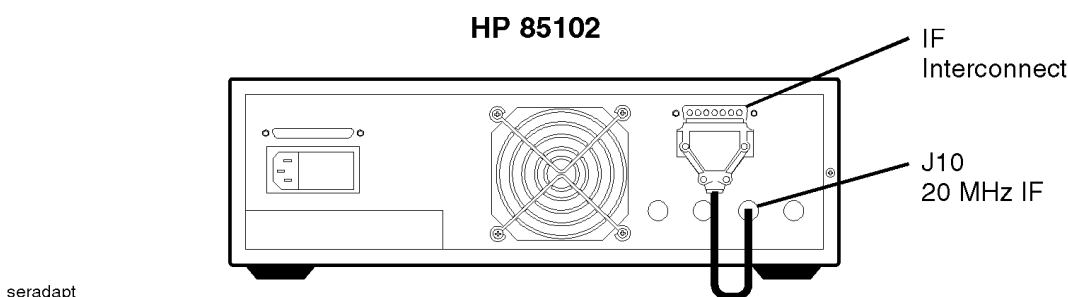

seradapt

Figure 5-8 Service Adapter Connections

Using the Service Adapter

1. Connect the service adapter as shown in Figure 5-8. On the network analyzer, press:
 INSTRUMENT STATE [PRESET]
 MENUS [MARKER]
 STIMULUS [MENU]
 {STEP}
 PARAMETER [MENU]
2. Examine each user parameter by pressing the {USER 1 a1} through {USER 4 b1} softkeys to observe unratiod power level traces at each channel.
3. The traces should be flat lines, quite close to one another, as indicated by the marker value (typically about -28 dB, ±5 dB).

Service Adapter Conclusions

Table 5-5 *Results Observations*

If all channels look good	The HP 85102 is working properly. The problem is most likely in the source or the test set. Refer to Procedure 4, "Unratioed Power Tests" in this chapter.
If one or more channels look bad	The problem is most likely in the HP 85102. Refer to the HP 8510C On-Site Service Manual for information about troubleshooting the HP 85102.

Unratioed Power Test

We will examine six RF signal paths in the test set by observing their associated IF signals. Figure 5-10 through Figure 5-15 show the test set traces (and simplified block diagrams) that are typical for RF paths 1 through 6.

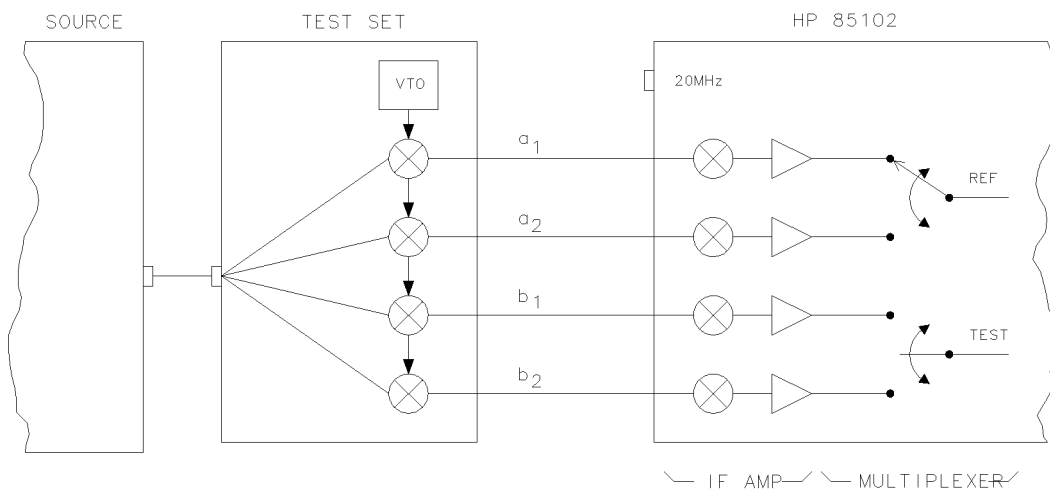

ifsig-

Figure 5-9 Diagram of IF Signal Path

Isolating Signal Path Problems

Determining the RF component in the test set that is most likely the cause of a failure can be accomplished within four steps:

1. Run the signal-path tests on paths 1 through 6 using the procedures on the following pages.
2. Record your test results in Table 5-6 for each path.
3. Compare the results in Table 5-6 with those in Table 5-7.
4. Investigate the most probable cause, based on the information in Table 5-7.

Testing Signal Paths 1-4

1. Set the network analyzer to its factory default settings by pushing the front-panel TEST switch.
2. Set the source for step mode. Press the network analyzer keys:

INSTRUMENT STATE [PRESET]
 STIMULUS [MENU]
 {STEP}

3. To examine each sampler's IF signal, redefine which port and sampler the network analyzer uses for the phase lock. Use the following steps:

a. Redefining to Port 2, sampler a2, press:

- ▲ PARAMETER [MENU]
- ▲ {USER 3 a2} then {REDEFINE PARAMETER}
- ▲ {DRIVE}
- ▲ DRIVE: {PORT 2}
- ▲ {PHASE LOCK}
- ▲ {a2}
- ▲ {REDEFINE DONE}

Observe the resulting a2 IF trace on the display.

b. Redefining to Port 2, sampler b2, press:

- ▲ {USER 2 b2} then {REDEFINE PARAMETER}
- ▲ {DRIVE}
- ▲ DRIVE: {PORT 2}
- ▲ {PHASE LOCK}
- ▲ {a2}
- ▲ {REDEFINE DONE}

Observe the resulting b2 IF trace on the display.

4. Connect an open (or short) to Port 1 and Port 2. Power is reflected back to b1 and b2 samplers through the coupler.

To check each sampler trace, press:

- ▲ {USER 1 a1}
- ▲ {USER 2 b2}
- ▲ {USER 3 a2}
- ▲ {USER 4 b1}

5. Record your results for paths 1 thru 4 ({USER 1} to {USER 4}) in Table 5-6.

NOTE

See Figure 5-10 for an RF signal-path 1 trace example. For Option 007, see Figure 5-13.

Testing Paths 5 and 6

1. Connect a cable between Port 1 and Port 2.
2. To observe the b1 power-level trace through path 5, press:
 - ▲ PARAMETER [MENU]
 - ▲ {USER 4 b1} then {REDEFINE PARAMETER}
 - ▲ {DRIVE}
 - ▲ DRIVE: {PORT 2}
 - ▲ {PHASE LOCK}
 - ▲ {a2}
 - ▲ {REDEFINE DONE}

The b1 path signal is illustrated in Figure 5-12. Typically, each trace should resemble the examples in Figure 5-12, (± 5 dB).

3. Record your results in Figure 5-6.
4. To observe the b2 power level trace through path 6, press:
 - ▲ PARAMETER [MENU]
 - ▲ {USER 2 b2} then {REDEFINE PARAMETER}
 - ▲ {DRIVE}
 - ▲ DRIVE: {PORT 1}
 - ▲ {PHASELOCK}
 - ▲ {a1}
 - ▲ {REDEFINE DONE}

The b2 path signal is illustrated in Figure 5-12. Typically, each trace should resemble the examples in Figure 5-12, (± 5 dB).

5. Record your results in Figure 5-6.

NOTE

Be sure that you return the parameters to their original conditions for a1, b1, a2, and b2. Use the redefine function to achieve this, or push the instrument TEST switch to restore factory default conditions.

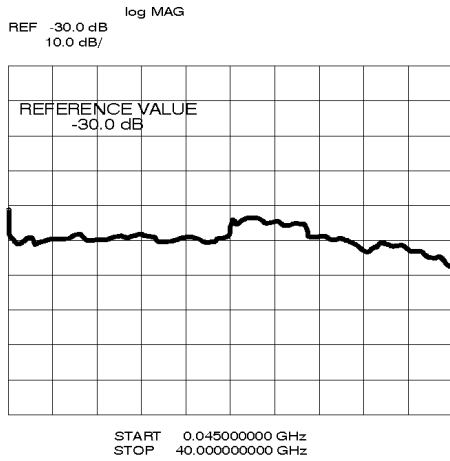

Path 1 - a1

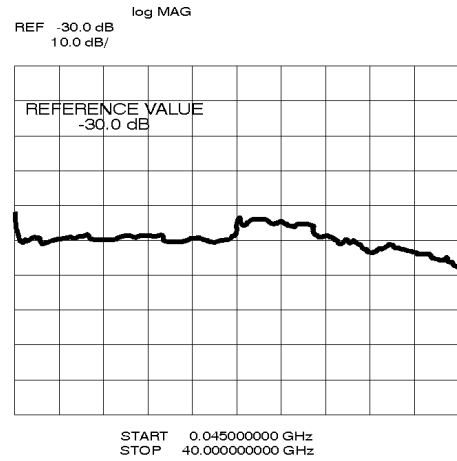

Path 2 - a2

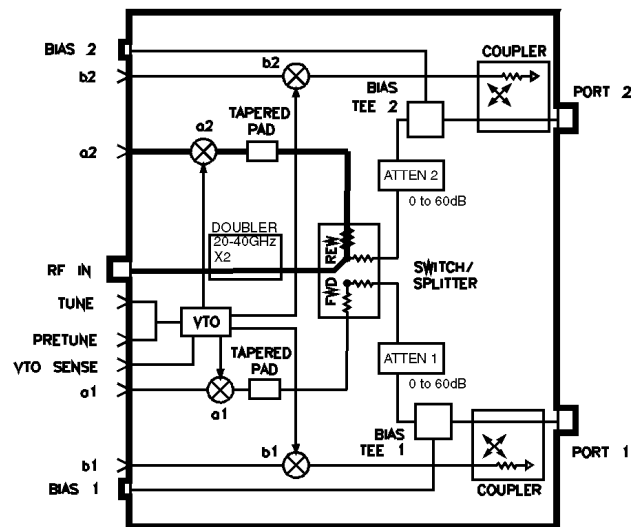
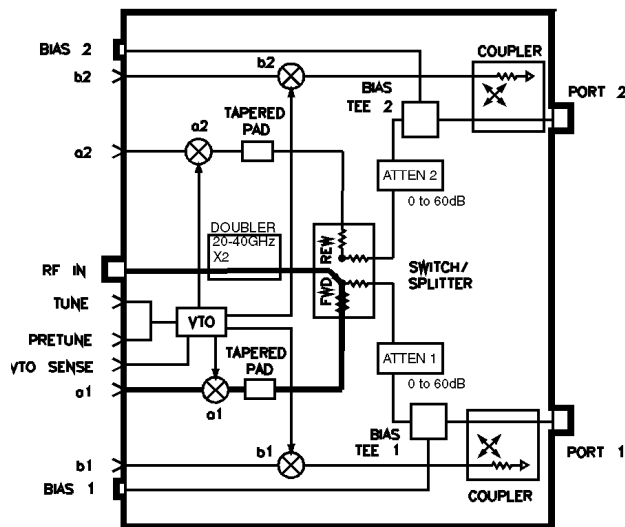

flow10

Figure 5-10 RF Path 1 and Path 2, HP 8517B Standard Test Set

Troubleshooting the Test Set
 Troubleshooting Procedures

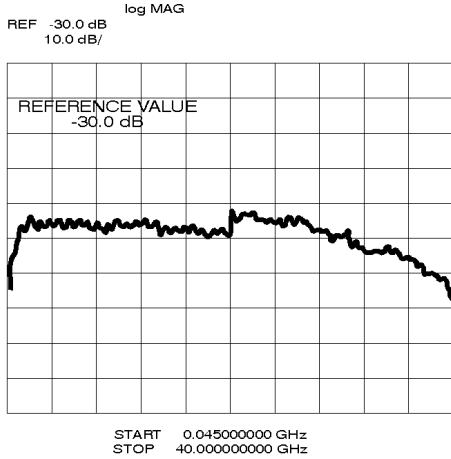

Path 3 - b1 Reflected

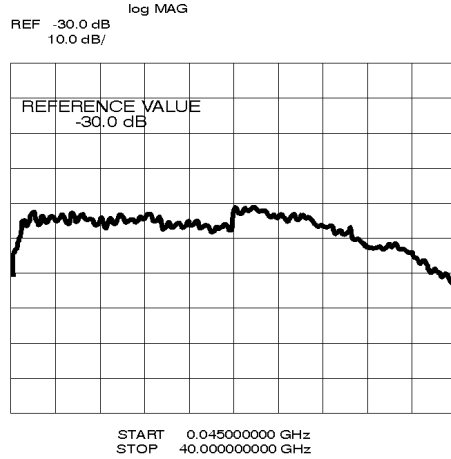

Path 4 - b2 Reflected

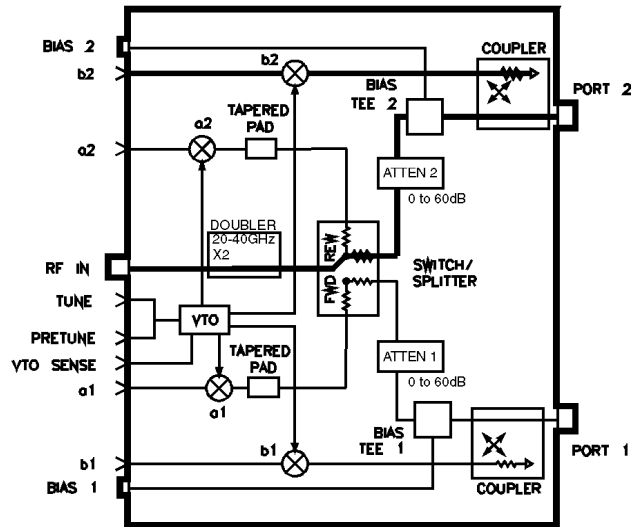
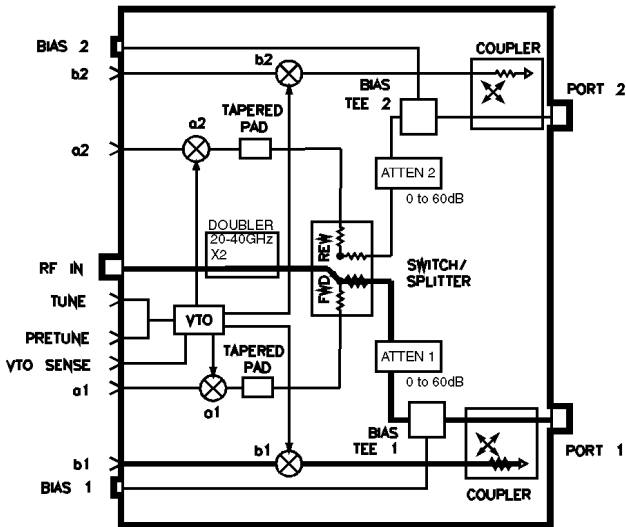

flow11

Figure 5-11 RF Path 3 and Path 4, HP 8517B Standard Test Set

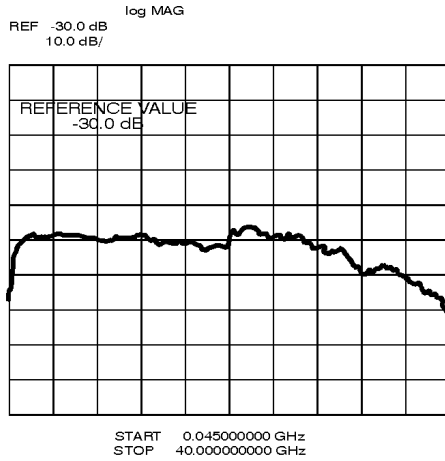

Path 5 - b1 Thru

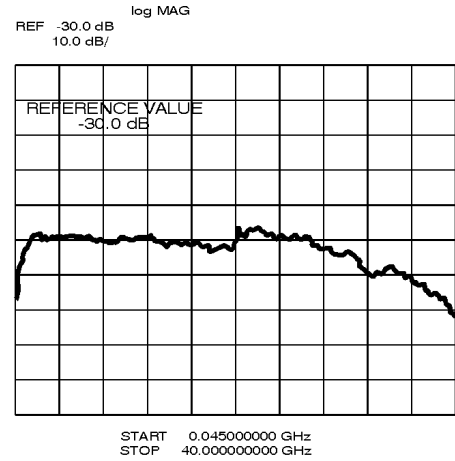

Path 6 - b2 Thru

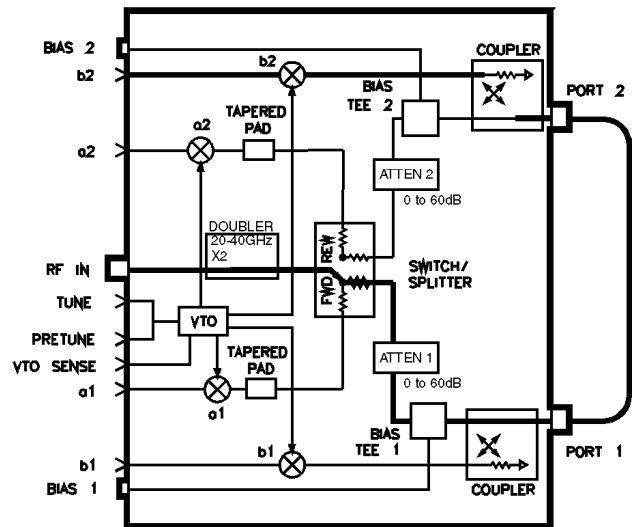
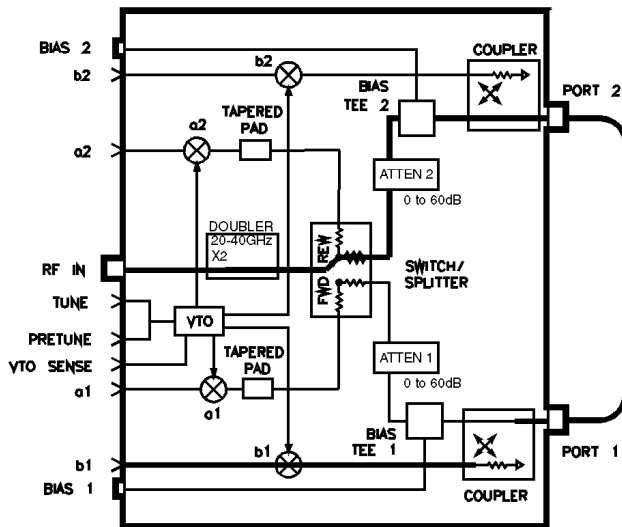

flow12

Figure 5-12 RF Path 5 and Path 6, HP 8517B Standard Test Set

**HP 8517B, Option 007
 Unratiod Power Test**

Figure 5-13 through Figure 5-15 illustrate the signal path and trace display for the unratiod power tests on HP 8517B, Option 007 model test sets.

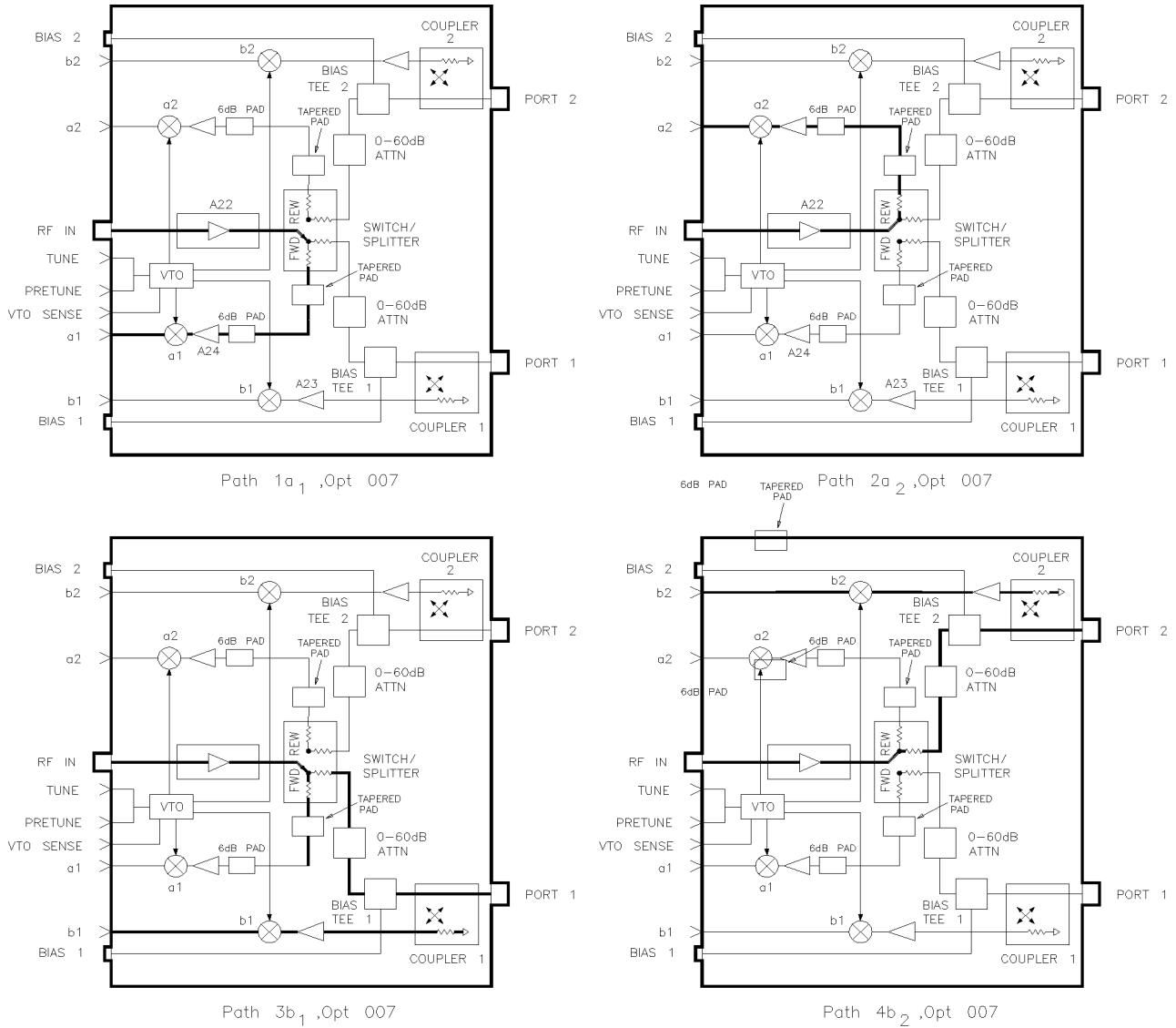

paths1007

Figure 5-13 RF Path 1 through Path 4, HP 8517B Option 007 Test Set

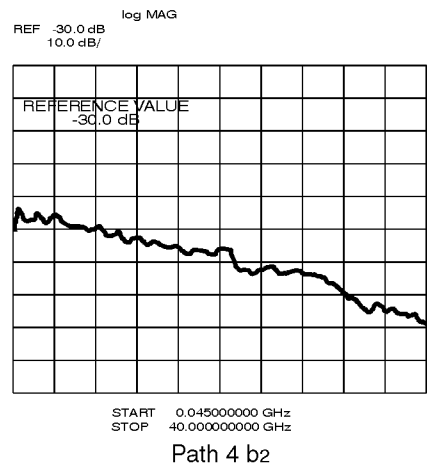
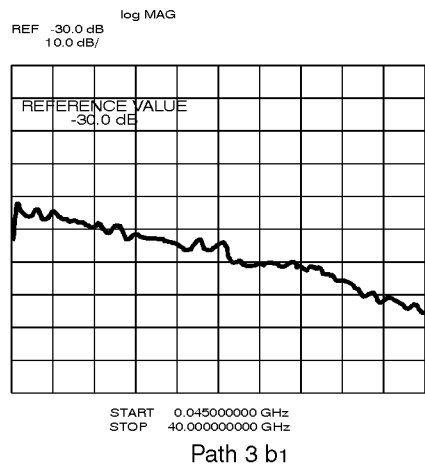
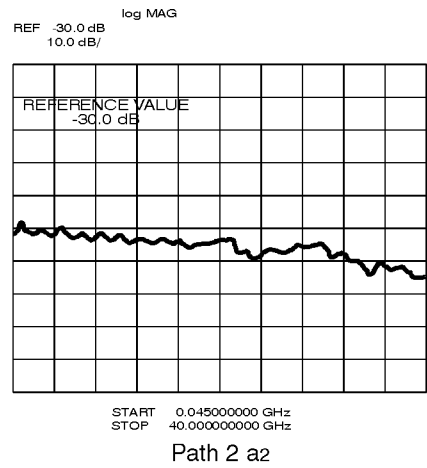
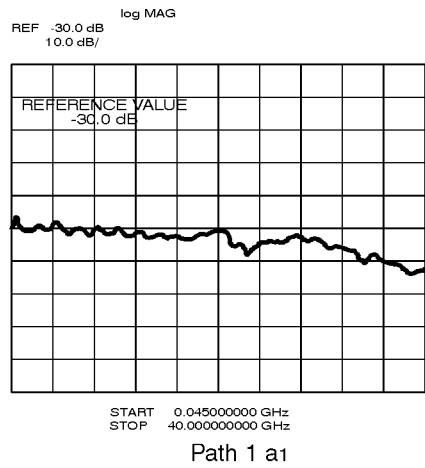

wform2

Figure 5-14 RF Signal for Path 1 through Path 4, HP 8517B Option 007

Troubleshooting the Test Set
 Troubleshooting Procedures

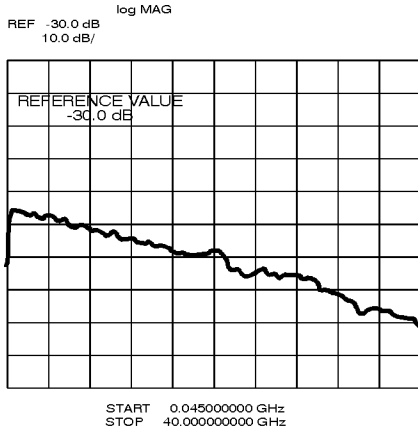

Path 5 - b1 Thru

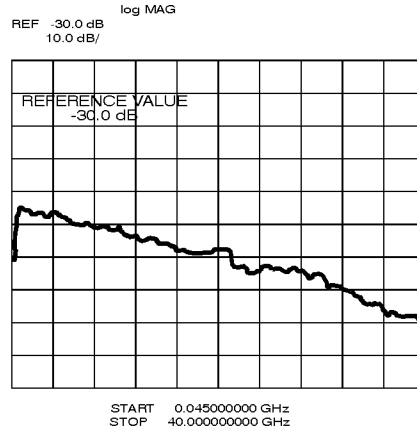

Path 6 - b2 Thru

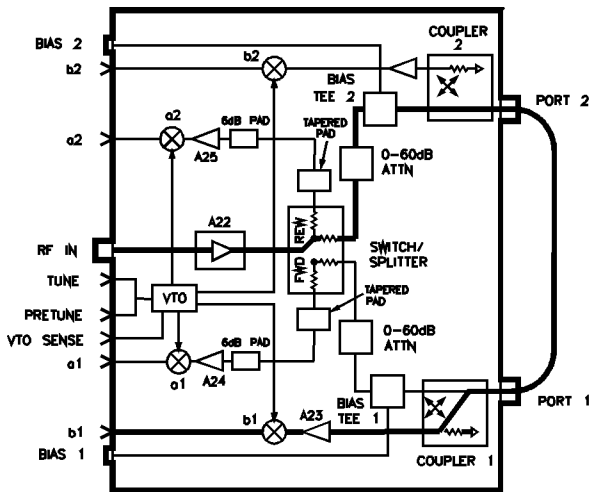

Path 5 - b1, Opt.007

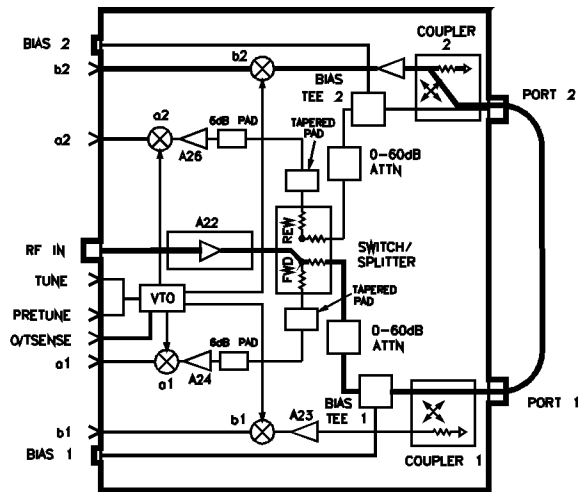

Path 6 - b2, Opt. 007

paths2007

Figure 5-15 RF Path 5 and Path 6, HP 8517B Option 007

Troubleshooting the Test Set
Troubleshooting Procedures

6

HP 8517B Test Set Replacement Procedures

The replacement procedures in this chapter are listed below:

- 1 “A18 Switch/Splitter Assembly” on page 6-5
- 2 “A14, A10 to A13 Frequency Converter Assembly” on page 6-5
- 3 “A15 Regulator Board Assembly” on page 6-6
- 4 “C1 to C4 Filter Capacitors” on page 6-6
- 5 “2.4 mm Test Port Connectors” on page 6-7
- 6 “Fan Assembly Replacement” on page 6-8
- 7 “T1 Power Transformer” on page 6-8
- 8 “Anti-Rotation Clamp O-Ring Replacement” on page 6-10
- 9 “A1 Front Panel and Interface Board Assembly” on page 6-10
- 10 “A7 and A9 Bias Tees” on page 6-11
- 11 “A6 and A8 Test Port Couplers” on page 6-11
- 12 “A16 or A17 Port Attenuators” on page 6-11
- 13 “A22 Input Amplifier Assembly” on page 6-12
- 14 “A23 to A26 Buffer Amplifiers” on page 6-12
- 15 “A27 Post Regulator Board Assembly” on page 6-13

CAUTION

To prevent electrostatic discharge (ESD) damage, earth ground the work area and yourself. Some of the assemblies being handled in the following procedures are very sensitive to damage resulting from static discharges. Assemblies exposed to ESD may or may not continue to operate properly. Their reliability, however, will be degraded. Refer to Figure 6-1 for ESD-safe workstation recommendations.

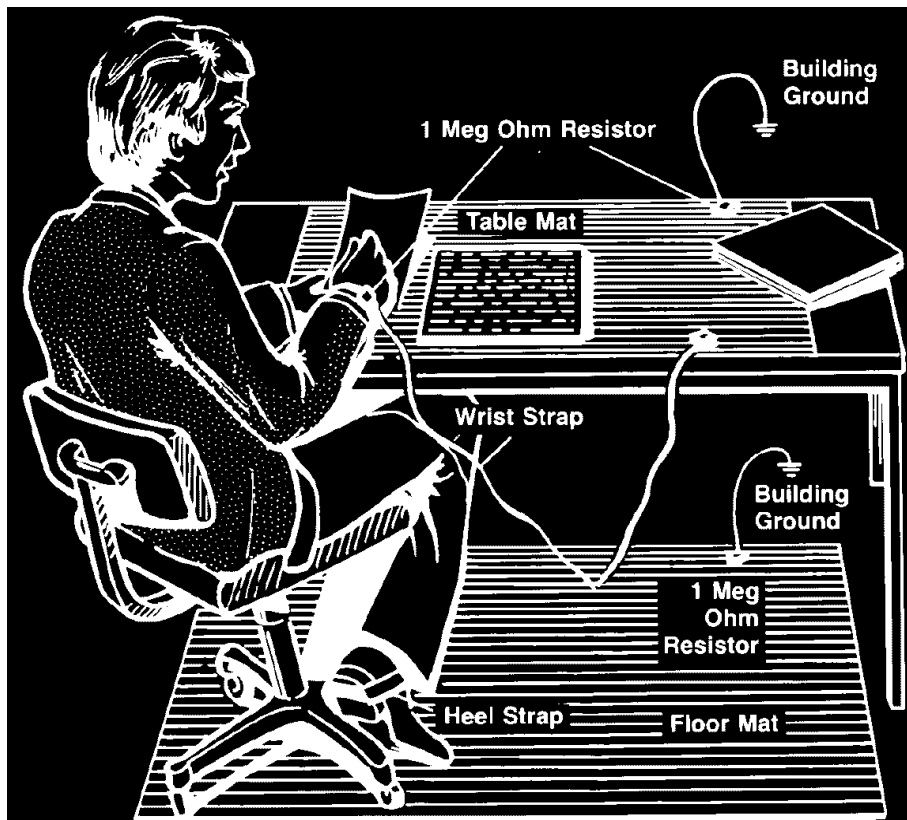

Figure 6-1 ESD-Safe Workstation Configuration

Performance Tests

Performance test information and procedures are located in Chapter 8 of the *HP 8510C On-Site Service Manual*.

Note that the HP 8510C performance test software (shipped with the test set) is required to test the test set. The results generated during the HP 8517B performance-test are based on its operation as part of the HP 8510C system. The HP 8510C includes the test set, cables, calibration kit, and so forth.

Adjustments

The HP 8517B Test Set has no adjustments. Specifically, no attempt should be made to adjust the samplers.

Equipment Needed But Not Supplied

Table 6-1 lists the equipment needed to replace the assemblies documented in the following procedures. See Figure 6-2 to locate the test set assemblies.

Table 6-1 Replacement-Procedure Tools Needed

Tools	Used for Procedure:	HP Part Number
2 point Pozidriv screwdriver	all components	8710-0900
1 point Pozidriv screwdriver	all components	8710-0899
5/16 inch torque wrench, 90 N-cm (8 in-lb)	all components and 3.5 mm semi-rigid cables, 2.4/1.85 mm cables	8710-1765
5/16 inch torque wrench, 112 N-cm (10 in-lb)	HP 8516A 2.4 mm semi-rigid cables	8710-1655
1/2 inch torque wrench, 280 N-cm (25 in-lb)	7 mm, 2.4 mm, 1.85 mm test port connectors	8710-1581
9/16 inch torque wrench, 470 N-cm (42 in-lb)	HP 8517B rear panel 2.4 mm connectors	8710-1580
20 mm torque wrench, 90 N-cm (8 in-lb)	2.4 mm and 1.85 mm test port connectors	8710-1764
2.9 mm gage kit	port connectors	Part of HP 85056A Cal Kit
anti-static mat	all components	9300-0797
wrist strap	all components	9300-1257
clip lead	C1-C4 capacitors	any supplier
needle nose pliers	couplers	any supplier
wire cutters	couplers, B1 fan	any supplier
T-10 Torx screwdriver	all components	8710-1623
T-15 Torx screwdriver	all components	8710-1622
9/16 inch 50 in-lb torque wrench	test ports	8710-1948
9/16 inch nut driver	connector repair	8720-0008
1/2 inch torque wrench, 280 N-cm (25 in-lb)	connector repair	8710-1581
100 Ω 20 watt resistor	C1-C4 capacitor removal	0819-0019
1 inch torque wrench, 800 N-cm (72 in-lb)	coupler removal and test port connector flange removal	MTB 100 72 lb-in E ¹
5/16 inch open end wrench	fan replacement and test port connector removal	any supplier
1/2 inch open-end wrench	RF input connector	any supplier
1/2 x 9/16 inch thin wrench, fixed	Test port connector removal	8710-1770
5/16 inch thin wrench	3.5 mm, 2.4 mm, 1.85 mm semi-rigid connector removal	8710-2079

1. Order from Mountz Company, 1080 North 11th Street, San Jose, CA 95112, phone (408) 292-2214, or contact Mountz through the internet at <http://www.mountztorque.com/html/home.htm>

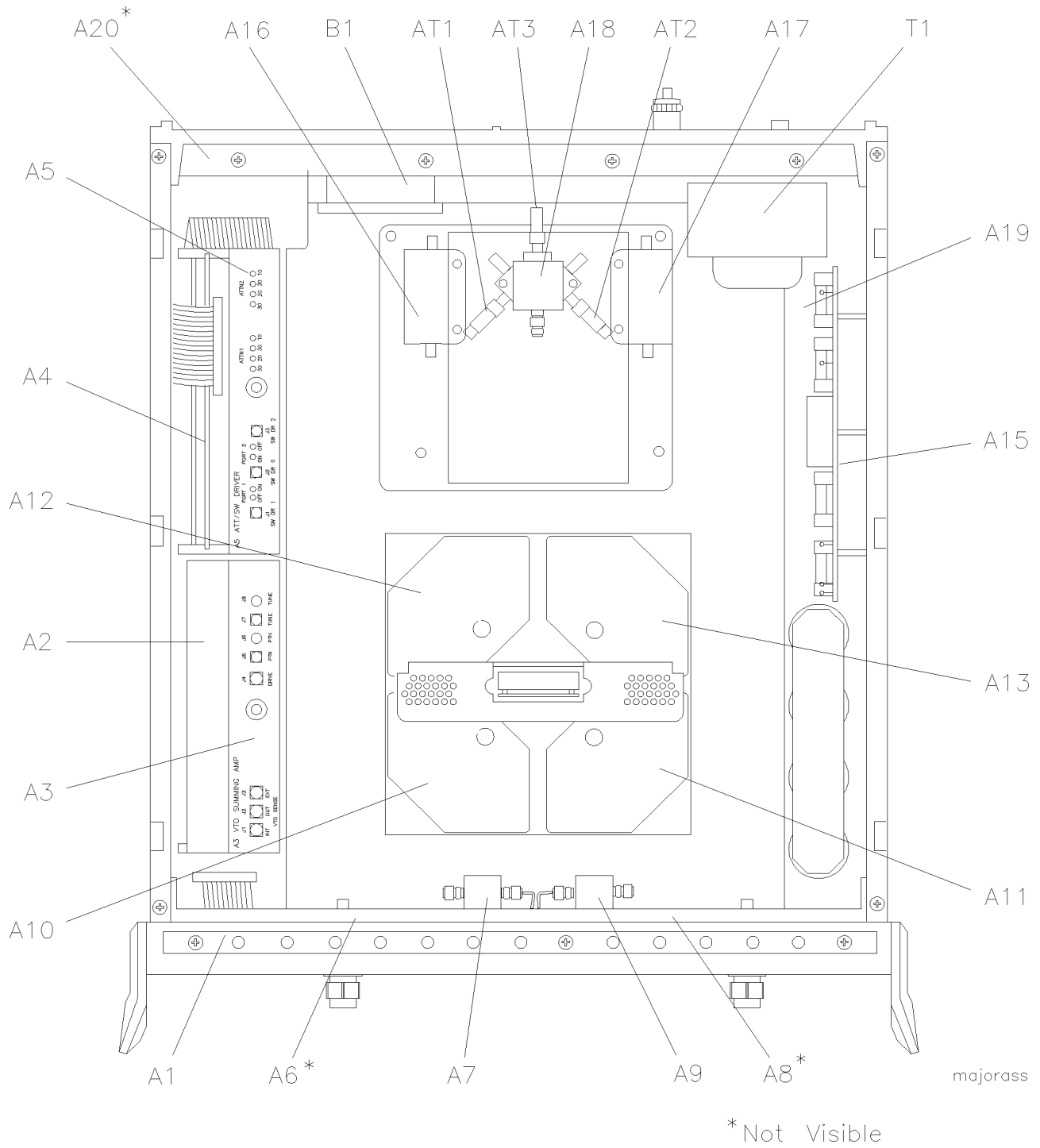

Figure 6-2 HP 8517B Major Assembly Location Diagram

Assembly Replacement Procedures

Initial Precautions

Before beginning any of the procedures in this chapter, do the following:

1. Turn off the HP 8517B test set.
2. Disconnect the test set's power cord.
3. Remove the top- and side-covers, trim strips, and handles.
4. Do not exceed the maximum torque necessary to secure a connector. Refer to Table 6-1 for torque specifications.
5. Exercise caution with semi-rigid cables; they can be bent very easily.
6. Reverse an assembly's removal procedure for reinstallation, unless otherwise instructed.

Switch/Splitter Replacement

A18 Switch/Splitter Assembly

1. See Table 6-2 for component locations.
2. Remove the five semi-rigid cables and the three flexible cables from the switch/splitter. (Reposition cables as required to ease removal.)
3. Remove the two fixed attenuators from the switch/splitter (note that there are three fixed attenuators in Option 007, and in Option 004 "plus" 007).
4. Remove the two screws that attach the switch/splitter to the bracket.
5. Remove the switch/splitter from the test set.

Frequency Converter Replacement

A14, A10 to A13 Frequency Converter Assembly

The frequency converter consists of the A14 VTO (voltage-tuned oscillator) assembly and four samplers, A10 through A13. See Figure 6-2 for component locations.

1. Remove the semi-rigid cable attached to each of the four samplers.
2. Remove the four in-line attenuators from the samplers (only in Options 007, Option 002 "plus" 007, and Option 004 "plus" 007).
3. Remove the six flexible cables from the frequency converter by pulling gently on the gold connector.
4. Remove the four frequency converter mounting plate screws and the bracket screw that fastens the frequency converter to the chassis.
5. Unplug the ribbon cable near the front panel.

Assembly Replacement Procedures

6. Unplug the four harnessed (multi-colored) wire and socket assemblies.
7. Lift the frequency converter out of the test set.
8. Remove the frequency converter bracket by removing the two Pozidriv screws.

Regulator Board Replacement

A15 Regulator Board Assembly

1. See Figure 6-2 for component locations.
2. Unplug the transformer socket from the regulator board.
3. Unplug the amplifier socket from the regulator board (only in Options 007, Option 002 “plus” 007, and Option 004 “plus” 007).
4. Remove the three mounting screws from the top edge of the regulator board.
5. Remove the regulator board. (You may need to partially back out one of the transformer mounting screws for clearance.)

Filter Capacitor Replacement

C1 to C4 Filter Capacitors

1. With the test set in an upright position, pull the metal and plastic cover off the 4 capacitors. See Figure 6-2 for the location of the filter capacitors.
2. Turn the test set over and remove the bottom cover.
3. To discharge the capacitors, do the following:
 - a. Attach one end of an insulated clip lead to the chassis of the instrument.
 - b. Attach the other end of the clip lead to a 100 $\text{p}\Omega$ 20-watt resistor.
 - c. Use the resistor to discharge each capacitor terminal (the large Pozidriv screw on the bottom side of the test set). Each capacitor has two terminals.
 - d. Discharge all capacitor terminals. It takes approximately six seconds per capacitor to discharge.
4. To remove a capacitor, remove the corresponding pair of screws and pull the capacitor out of the test set.

Test Port Connector Replacement

2.4 mm Test Port Connectors

1. Incline the rear of the test set approximately four inches and support it with a stable, solid object (such as a thick book).
2. Using a 9/16-inch open-end wrench, unscrew the test port connector nut.
3. Pull out the center conductor assembly and replace it with a new assembly. *Do not touch either end of the new assembly.* Part numbers for the test port connector components are located on page 7-16.
4. Replace the test port connector nut and torque it to 562 N-cm (50 in-lb).
5. Measure the pin depth of each port using a 2.4 mm female pin-depth gage. Refer to the connector care information in the calibration kit manual for more information about using the gage.

NOTE

If the center pin protrudes, or if the depth is less than 0.0001 inch, remove the connector assembly and increase or decrease shims to adjust the pin depth to between 0.0001 and 0.0007 inch. When measuring the pin depth be sure to include the uncertainty calculation of your gage.

6. If you added or removed shims, regage the test port connector assembly.

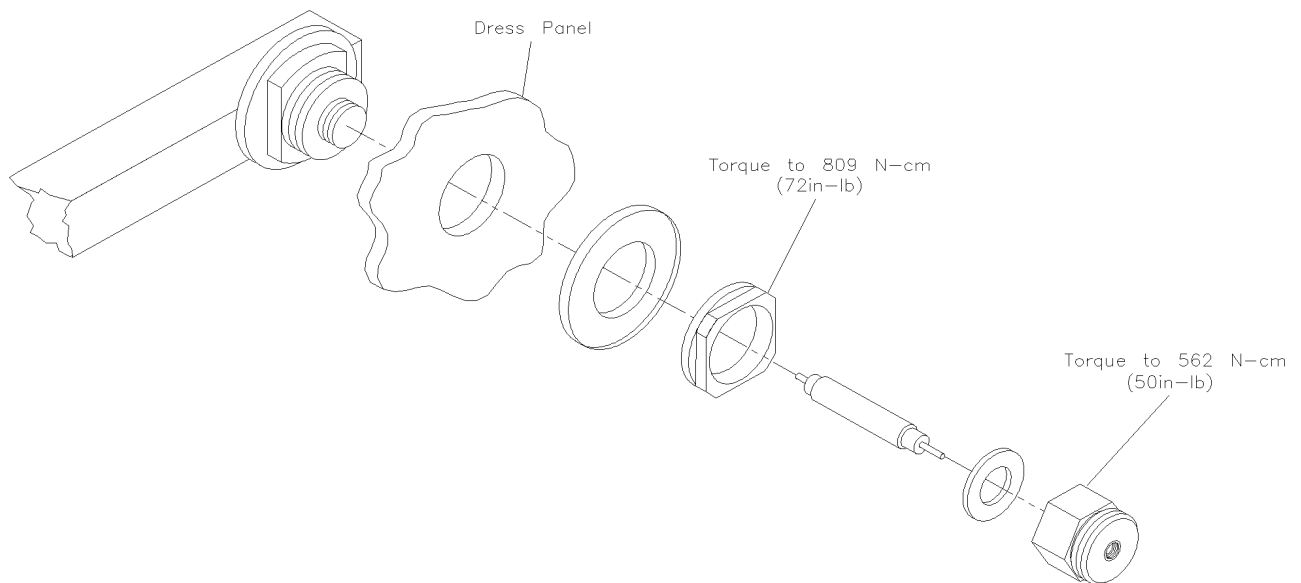

coniso

Figure 6-3 Diagram of 2.4 mm Test Port Connector

Fan Assembly Replacement

WARNING

B1 Fan Assembly

Turn off the test set and disconnect the power cord from the ac-power mains.

Electrocution can result if ac power remains connected to the test set during this procedure. Disconnect the ac power cord before starting.

To replace the B1 fan assembly, remove T1 transformer to expose the ends of the fan wires which must be de-soldered from the line module, FL1. Refer to Chapter 7, "Replaceable Parts" in this manual for a detailed view of the fan and transformer hardware.

1. See Figure 6-2 for component locations.
2. Position the test set on its right-hand side.
3. Using a 5/16-inch open-end wrench, remove the hard-line cables connected between the couplers A7 and A9 and the bulkhead connectors J2 and J5.
4. Unplug the transformer connector at J2 on the A15 regulator board.
5. Using a large Pozidriv screwdriver, remove the four screws and washers that hold the transformer onto the rear panel.
6. Using a large Pozidriv screwdriver, remove the screw that holds the transformer angle bracket to the main deck.

NOTE

The transformer wires soldered to the line module are short, so do not pull the transformer out too far.

7. Carefully remove the transformer from the test set and place it on the bench near the test set.
8. Strip the heat shrink tubing off the two fan wires, then de-solder the wires from the line module. Cut any cable ties restraining the fan wires.
9. Using a small Pozidriv screwdriver, remove the screw and lockwasher that secure the green/yellow fan ground wire to the top of the rear panel frame.
10. Using a small Pozidriv screwdriver, remove the four screws that hold the fan to the rear panel. Remove the fan assembly.

Power Transformer Replacement

T1 Power Transformer

Turn off the test set and disconnect the power cord from the mains.

WARNING

Electrocution can result if ac power remains connected to the test set during this procedure. Disconnect the ac power cord before starting.

1. See Figure 6-2 for component locations.
2. Position the test set onto its right-hand side.
3. Using a 5/16-inch open-end wrench, remove the hard-line cables connected between the coupler A7 and the bulkhead connector J2.
4. Unplug the transformer connector from J2 on the A15 regulator board.
5. Using a large Pozidriv screwdriver, remove the four screws and washers that hold the transformer onto the rear panel.
6. Using a large Pozidriv screwdriver, remove the screw that holds the transformer angle bracket to the main deck.

NOTE

The transformer wires soldered to the line module are short, so do not pull the transformer out too far.

7. Carefully remove the transformer from the test set and place it on the bench near the test set.
8. Strip the heat shrink tubing off the transformer wires that are soldered to the line module, and de-solder the wires.
9. De-solder the transformer ground wire connected to the chassis side rail.
10. Remove the transformer. When you replace the transformer, refer to Figure 6-4 for the location of wires connected to the line module.

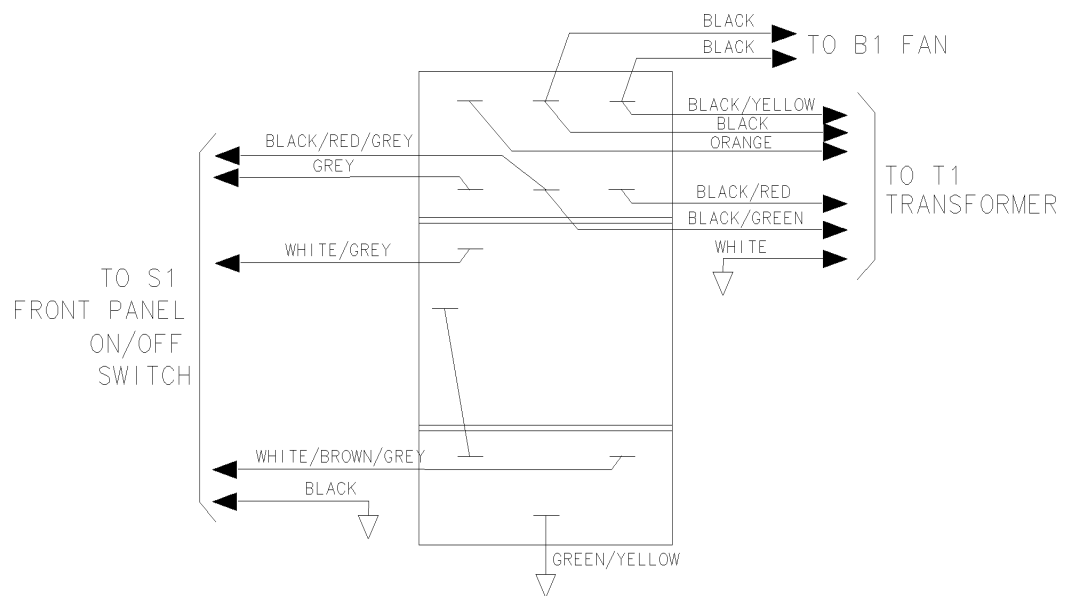

Figure 6-4 Wire Connections to FL1 Line Module

O-Ring Replacement

Anti-Rotation Clamp O-Ring Replacement

1. Pry the O-ring out of the clamp with fine tweezers or a similar tool.
2. To insert the new O-ring (HP part number 0900-0007), engage one side of the ring in the slot of the phenolic clamp donut (shown in Figure 6-5).
3. Use your fingers to seat the O-ring into the groove within the clamp.

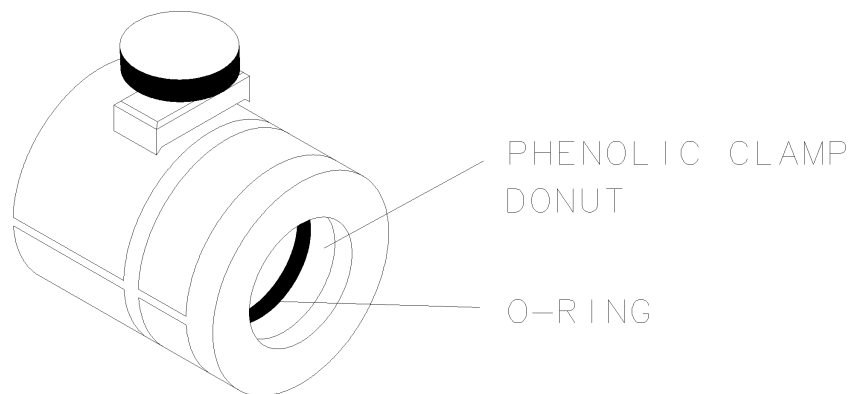

Figure 6-5 Positioning the O-Ring Within the Clamp

Front Panel and Interface Board Replacement

A1 Front Panel and Interface Board Assembly

1. See Figure 6-2 for component locations.
2. Remove the four semi-rigid cables that connect to the coupler on the front panel.
3. Remove the ten screws that secure the front panel assembly to the front frame.
4. Grasp the test ports and pull the front panel assembly out, tilting the top of the assembly toward you.
5. Unplug the ribbon cable attached to the board assembly on the front panel.
6. Grasp the cable attached to the line switch and carefully pull it toward the front of the instrument. This provides enough cable length for you to tilt the front panel assembly the rest of the way out of the test set frame.
7. Carefully remove the front panel assembly.
8. Lay the front panel assembly face down on the work surface.

Bias Tees Replacement

A7 and A9 Bias Tees

1. See Figure 6-2 for component locations.
2. Remove the two semi-rigid cables attached to the bias tee to be replaced.
3. De-solder the wires attached to the bias tee.
4. Remove the two screws that secure the bias tee to the bias-tee bracket.
5. Remove the bias tee.

NOTE

This procedure does not apply to Option 002 or Option 002 “plus” 007.

Test Port Coupler Replacement

A6 and A8 Test Port Couplers

1. See Figure 6-2 for component locations.
2. Remove the front panel assembly as described in the procedure “A1 Front Panel and Interface Board Assembly”.
3. Remove the test port connector nut with a 1-inch wrench.
4. Remove the test port washer.
5. Remove the coupler from the front panel.

Test Port Attenuator Replacement

A16 or A17 Port Attenuators

NOTE

This procedure does not apply to Option 002 or Option 002 “plus” 007.

1. See Figure 6-2 for component locations.
2. Remove the two semi-rigid cables attached to the attenuator.
3. Unplug the ribbon cable from the attenuator.
4. Remove the two screws that secure the attenuator bracket to the amplifier bracket.
5. Remove the attenuator/attenuator bracket from the instrument.
6. Remove the two screws that secure the attenuator to the attenuator bracket.

Input Amplifier Replacement

NOTE

A22 Input Amplifier Assembly

This procedure is for Option 007, Option 002 “plus” 007, and Option 004 “plus” 007, only.

1. See the figure in Chapter 7, Table 7-17 for the location of the A22 amplifier.
2. Without disconnecting AT1 and AT2 fixed attenuators, remove the other five semi-rigid cables attached to the A18 switch/splitter.
3. Remove the W45 semi-rigid cable between the A22 input amplifier and J7 rear-panel RF input connector.
4. Remove the two screws holding the switch/splitter to the amplifier mount bracket.
5. Remove the switch/splitter from the amplifier mount bracket.
6. Remove the four screws that secure the A22 input amplifier to the amplifier-mount bracket.

Buffer Amplifier Replacement

NOTE

A23 to A26 Buffer Amplifiers

This procedure is for Option 007, Option 002 “plus” 007, and Option 004 “plus” 007, only.

1. See the figure in Chapter 7, Table 7-17 for the location of the buffer amplifiers.
2. Remove the two semi-rigid cables from the buffer amplifier to be replaced.
3. Remove the four screws securing the buffer amplifier to the amplifier mount bracket.
4. Remove the buffer amplifier.

Post Regulator Board Replacement

A27 Post Regulator Board Assembly

NOTE

This procedure is for Option 007, Option 002 “plus” 007, and Option 004 “plus” 007, only.

1. See the figure in Chapter 7, Table 7-17 for the location of the A22 amplifier bracket. The A27 board assembly is located beneath the A22 amplifier bracket.
2. Without removing the step attenuator from the bracket (this step is not applicable to Option 002 “plus” 007), remove the four semi-rigid cables attached to the attenuators at Port 1 and Port 2.
3. Remove the four buffer amplifiers from the bracket (refer to “A23 to A26 Buffer Amplifiers”).
4. Remove the A18 switch/splitter assembly (refer to “A18 Switch/Splitter Assembly”).
5. Remove the A22 input amplifier (refer to “A22 Input Amplifier Assembly”).
6. Remove the four screws attaching the amplifier bracket to the test set.
7. Flip the amplifier bracket over. Note the A27 board assembly mounted to the underside of the bracket.
8. De-solder the two pins from the regulator to remove the A27 amplifier regulator board assembly.
9. Remove the five screws holding the board assembly to the bracket.
10. Remove the two screws holding the voltage regulator to the bracket.
11. Remove the regulator board assembly from the amplifier mount bracket.

NOTE

Do not loosen the grommets (HP part number 3050-0003) located on the regulator board assembly.

12. For reassembly, install two grommets on the underside of the mount bracket. There are two cut-outs on the sheet metal for these grommet insulators.

HP 8517B Test Set Replacement Procedures
Assembly Replacement Procedures

Introduction

This section provides information about ordering replacement parts. Parts that can be replaced include major assemblies and chassis hardware, but not individual pieces of major assemblies. Table 7-1 lists the major assembly reference designations and abbreviations used in the parts lists.

Rebuilt-Exchange Assemblies

Rebuilt-exchange assemblies (R-E assemblies) cost less than new assemblies. They are available through the rebuilt-exchange program. Factory rebuilt (repaired and tested) assemblies meet all factory specifications required of a new assembly. They are available on an exchange (trade-in) basis only. Defective assemblies must be returned for credit. Figure 7-2 illustrates the rebuilt-exchange procedure. The rest of the figures in this chapter provide parts information. If you have any questions, contact the HP Sales and Service office in your region.

Replaceable Parts List

Use the illustrations in this chapter to help locate and identify HP 8517B replaceable parts. Each illustration is accompanied by a replaceable parts list that includes the following information:

- Hewlett-Packard part number.
- Part quantity as shown in the corresponding figure. (There may or may not be more of the same part located elsewhere in the instrument.)
- Part description, using the abbreviations found in Table 7-3.

NOTE

A typical manufacturer of the part is identified by a five-digit code (refer to the Manufacturers Code list in Table 7-2) and given *only* if a part is available from an alternate supplier (other than Hewlett-Packard).

Ordering Information

To order parts listed in the replaceable parts table, record the following information, then address the order to the nearest Hewlett-Packard Sales and Service Office:

the Hewlett-Packard part number
the quantity required

To order parts not listed in the replaceable parts lists, record the following information:

the instrument model number
the complete instrument serial number
the description and function of the part, and
the number of parts required

Address the order to the nearest Hewlett-Packard Sales and Service Office. The office addresses are provided in "Service and Support" of this manual.

To Order Parts Fast!

- Telephone 1-(800) 227-8164
- Monday through Friday, 6 am to 5 pm (Pacific Standard Time)

Hewlett-Packard Parts specialists have direct on-line access to replacement parts inventory corresponding to the replaceable parts list in this manual. There is a charge for one day delivery service. The standard delivery time is four days.

For after hours and holidays, phone (415) 968-2347. The fast-service applies to United States customers, only. Outside the United States, contact your nearest Hewlett-Packard Sales and Service Office.

Table 7-1 Reference Designation Abbreviations

A	Assembly	F	Fuse	S	Switch
AT	Attenuator, Isolator, Limiter, Termination	FL	Filter	T	Transformer
B	Fan, Motor	HY	Circulator	TB	Terminal Block
BT	Battery	J	Electrical Connector (Stationary Portion), Jack	TC	Thermocouple
C	Capacitor	K	Relay	TP	Test Point
CP	Coupler	L	Coil, Inductor	U	Integrated Circuit, Microcircuit
CR	Diode, Diode Thyristor, Step Recovery Diode, Varactor	M	Meter	V	Electron Tube

Table 7-1 Reference Designation Abbreviations (Continued)

DC	Directional Coupler	MP	Miscellaneous Mechanical Part	VR	Breakdown Diode (Zener), Voltage Regulator
DL	Delay Line	P	Electrical Connector (Movable Portion), Plug	W	Cable, Wire, Jumper
DS	Annunciator, Lamp, Light Emitting Diode (LED), Signaling Device (visible)	Q	Silicon Controlled Rectifier (SCR), Transistor, Triode Thyristor	X	Socket
E	Miscellaneous Electrical Part	R	Resistor	Y	Crystal Unit (Piezoelectric, Quartz)
		RT	Thermistor	Z	Tuned Cavity, Tuned Circuit

Table 7-2 Manufacturer Names and Addresses

Manufacturer Code	Manufacturer Name	Manufacturer Address
00000	Any satisfactory supplier	N/A
00853	Sangamo Elec Co. S. Carolina Div	Pickens, SC 29671
24546	Corning Glass Works (Bradford)	Bradford, PA 16701
28480	Hewlett-Packard Co. Corporate HQ	Palo Alto, CA 94304
56289	Sprague Electric Company	North Adams, MA 01247

Table 7-3 Standard Abbreviations

A	
A	Across Flats, Acrylic, Air (Dry Method), Ampere
ADJ	Adjust, Adjustment
ANSI	American National Standards Institute (formerly USASI-ASA)
ASSY	Assembly
AWG	American Wire Gage
B	
BCD	Binary Coded Decimal
BD	Board, Bundle
BE-CU	Beryllium Copper
BNC	Type of Connector
BRG	Bearing, Boring
BRS	Brass
BSC	Basic
BTN	Button
C	
C	Capacitance, Capacitor, Cold, Center Tapped, Cermet, Compression
CCP	Carbon Composition Plastic
CD	Cadmium, Card, Cord
CER	Ceramic
CHAM	Chamfer
CHAR	Character, Characteristic, Charcoal
CMOS	Complementary Metal Oxide Semi-conductor
CNDCT	Conducting, Conductive, Conductivity, Conductor
CONT	Contact, Continuous, Control, Controller
CONV	Converter
CPRSN	Compression
CUP-PT	Cup point
D	
D	Deep, Depletion, Depth, Diameter, Direct Current
DA	Darlington
DAP-GL	Diallyl Phthalate Glass
DBL	Double

Table 7-3 Standard Abbreviations (Continued)

DCDR	Decoder
DEG	Degree
D-HOLE	D-Shaped hole
DIA	Diameter
DIP	Dual In-Line Package
DIP-SLDR	DIP Solder
DO	Package Type Designation
DP	Deep, Depth, Diametric Pitch, Dip
D-MODE	Depletion Mode
DP3T	Double Pole Triple Throw
DPDT	Double Pole Double Throw
DWL	Dowel
E	
E-R	E-Ring
EXT	Extended, Extension, External, Extinguish
F	
F	Fahrenheit, Farad, Female, Fixed, Flange, Frequency, Film (Resistor)
FC	Carbon Film/Composition, Edge of Cut-off Frequency, Face
FDTHRU	Feed-through
FEM	Female
FIL-HD	Fillister Head
FL	Flash, Flat, Fluid
FLAT-PT	Flat Point
FR	Front
RFEQ	Frequency
FT	Current Gain Bandwidth Product (Transition Frequency), Feet, Foot
FXD	Fixed
G	
GEN	General, Generator
GND	Ground
GP	General Purpose, Group
H	
H	Henry

Table 7-3 Standard Abbreviations (Continued)

HDW	Hardware
HEX	Hexadecimal, Hexagon, Hexagonal
HLCL	Helical
HP	Hewlett-Packard Company, High Pass
I	
IIC	Collector Current, Integrated Circuit
ID	Identification, Inside Diameter
IF	Intermediate Frequency, Forward Current
IN	Inch
INCL	Including
INT	Integral, Intensity, Internal
J	
J-FET	Junction Field Effect Transistor
JFET	Junction Field Effect Transistor
K	
K	Kelvin, Key, Kilo, Potassium
KNRLD	Knurled
KVDC	Kilovolts Direct Current
L	
LED	Light Emitting Diode
LG	Length, Long
LIN	Linear, Linearity
LK	Link, Lock
LKG	Leakage, Locking
LUM	Luminous
M	
M	Male, Maximum, Mega, Mi, Milli, Mode
MA	Milliampere
MACH	Machined
MAX	Maximum
MC	Molded Carbon Composition
MET	Metal, Metallized
MHZ	Mega Hertz

Table 7-3 Standard Abbreviations (Continued)

MINTR	Miniature
MIT	Miter
MLD	Mold, Molded
MM	Magnetized Material, Millimeter
MOM	Momentary
MTG	Mounting
MTLC	Metallic
MW	Milliwatt
N	
N	Nano, None
N_CHAN	N-Channel
NH	Nano Henry
NM	Nanometer, nonmetallic
NO	Normally Open, Number
NOM	Nominal
NPN	Negative Positive Negative (Transistor)
NS	Nanosecond, Non-Shorting, Nose
NUM	Numeric
NYL	Nylon (Polyamide)
O	
OA	Over-All
OD	Outside Diameter
OP AMP	Operational Amplifier
Opt	Optical, Option, Optional
P	
PA	Picoampere, Power Amplifier
PAN-HD	Pan Head
PAR	Parallel, Parity
PB	Lead (Metal), Push-button
PC	Printed Circuit
PCB	Printed Circuit Board
P-CHAN	P-Channel
PD	Pad, Power Dissipation

Table 7-3 Standard Abbreviations (Continued)

PF	Pico Farad, Power Factor
PKG	Package
PLSTC	Plastic
PNL	Panel
PNP	Positive Negative Positive (Transistor)
POLYC	Polycarbonate
POLYE	Polyester
POT	Potentiometer
POZI	Pozidriv Recess
PREC	Precision
PRP	Purple, Purpose
PSTN	Piston
PT	Part, Point, Pulse Time
PW	Pulse Width
Q	
Q	Figure of Merit
R	
R	Range, Red, Resistance, Resistor, Right, Ring
REF	Reference
RES	Resistance, Resistor
RF	Radio Frequency
RGD	Rigid
RND	Round
RR	Rear
RVT	Rivet, Riveted
S	
SAWR	Surface Acoustic Wave Resonator
SEG	Segment
SGL	Single
SI	Silicon, Square Inch
SL	Slide Slow
SLT	Slot, Slotted
SMA	Subminiature, A-Type (Threaded Connector)

Table 7-3 Standard Abbreviations (Continued)

SMB	Subminiature, B-Type (Slip-on Connector)
SMC	Subminiature, C-Type (Threaded Connector)
SPCG	Spacing
SPDT	Single Pole Double Throw
SPST	Single Pole Single Throw
SQ	Square
SST	Stainless Steel
STL	Steel
SUBMIN	Subminiature
SZ	Size
T	
T	Teeth, temperature, Thickness, Time, Timed, Tooth, Typical
TA	Ambient Temperature, Tantalum
TC	Temperature Coefficient
THD	Thread, Threaded
THK	Thick
TO	Package Type Designation
TPG	Tapping
TR-HD	Truss Head
TRMR	Trimmer
TRN	Turn, Turns
TRSN	Torsion
U	
UCD (or μ CD)	Microcandela
UF (or μ F)	Micro Farad
UH (or μ H)	Micro Henry
UL (or μ CD)	Microliter, Underwriters' Laboratories, Inc.
UNHDND	Unhardened
V	
V	Variable, Violet, Volt, Voltage
VAC	Vacuum, Volt—Alternating Current

Table 7-3 Standard Abbreviations (Continued)

VAR	Variable
VDC	Volts—Direct Current
W	
W	Watt, Wattage, White, Wide, Width
W/SW	With, Switch
WW	Wire Wound
X	
X	By (as used with dimensions), Reactance
Y	
YIG	Yttrium-Iron-Garnet
Z	
ZNR	Zener Diode

Table 7-4 Multipliers, Abbreviation and Description

Abbreviation	Prefix	Multiple
T	tera	10^{12}
G	giga	10^9
M	mega	10^6
k	kilo	10^3
da	deka	10^2
d	deci	10^{-1}
c	centi	10^{-2}
m	milli	10^{-3}
μ	micro	10^{-6}
n	nano	10^{-9}
p	pico	10^{-12}
f	femto	10^{-15}
a	atto	10^{-18}



PLUG TYPE **	CABLE HP PART NUMBER	PLUG DESCRIPTION	CABLE LENGTH CM (INCHES)	CABLE COLOR	FOR USE IN COUNTRY
250V 	8120-1351 8120-1703	Straight* BS1363A 90°	229 (90) 229 (90)	Mint Gray Mint Gray	Great Britain, Cyprus, Nigeria, Singapore, Zimbabwe
250V 	8120-1369 8120-0696	Straight* NZSS198/ASC112 90°	201 (79) 221 (87)	Gray Gray	Argentina, Australia, New Zealand, Mainland China
250V 	8120-1689 8120-1692	Straight* CEE7-Y11 90°	201 (79) 201 (79)	Mint Gray Mint Gray	East and West Europe, Central African Republic, United Arab Republic (unpolarized in many nations)
125V 	8120-1348 8120-1538	Straight* NEMA5-15P 90°	203 (80) 203 (80)	Black Black	United States Canada, Japan (100 V or 200 V), Brazil, Colombia, Mexico, Philippines, Saudia Arabia, Taiwan
	8120-1378	Straight* NEMA5-15P	203 (80)	Jade Gray	Israel
	8120-4753	Straight	230 (90)	Jade Gray	
	8120-1521 8120-4754	Straight 90° 90°	203 (80) 230 (90)	Jade Gray Jade Gray	
250V 	8120-5182 8120-5181	Straight* NEMA5-15P 90°	200 (78) 200 (78)	Jade Gray Jade Gray	
<p>* Part number for plug is industry identifier for plug only. Number shown for cable is HP Part Number for complete cable, including plug.</p> <p>** E = Earth Ground; L = Line; N = Neutral.</p>					

Figure 7-1 Power Cable and Plug Part Numbers

Table 7-5 Instrument Fuses

Fuse	Name	Location	Amps for 100 to 120 Vac (part number)		Amps for 220 to 250 Vac (part number)	
ac Line	F1	Rear Panel	2.0	2110-0002	1.0	2110-0001
+5 Vdc	F1	Regulator Board	1.5	2110-0043	1.5	2110-0043
- 5 Vdc	F2	Regulator Board	1.0	2110-0001	1.0	2110-0001
+15 Vdc	F3	Regulator Board	1.5	2110-0043	1.5	2110-0043
- 15 Vdc	F4	Regulator Board	1.0	2110-0001	1.0	2110-0001
Bias	Bias Fuses	Front Panel	0.5	2110-0012	0.5	2110-0012

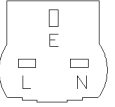
Use this fast, efficient, economical method to keep your Hewlett-Packard instrument in service.

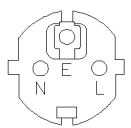
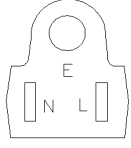
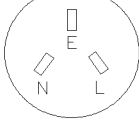
Use this fast, efficient economical method to keep your Hewlett-Packard instrument in service.

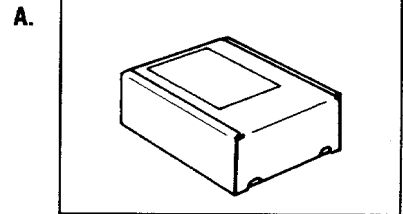
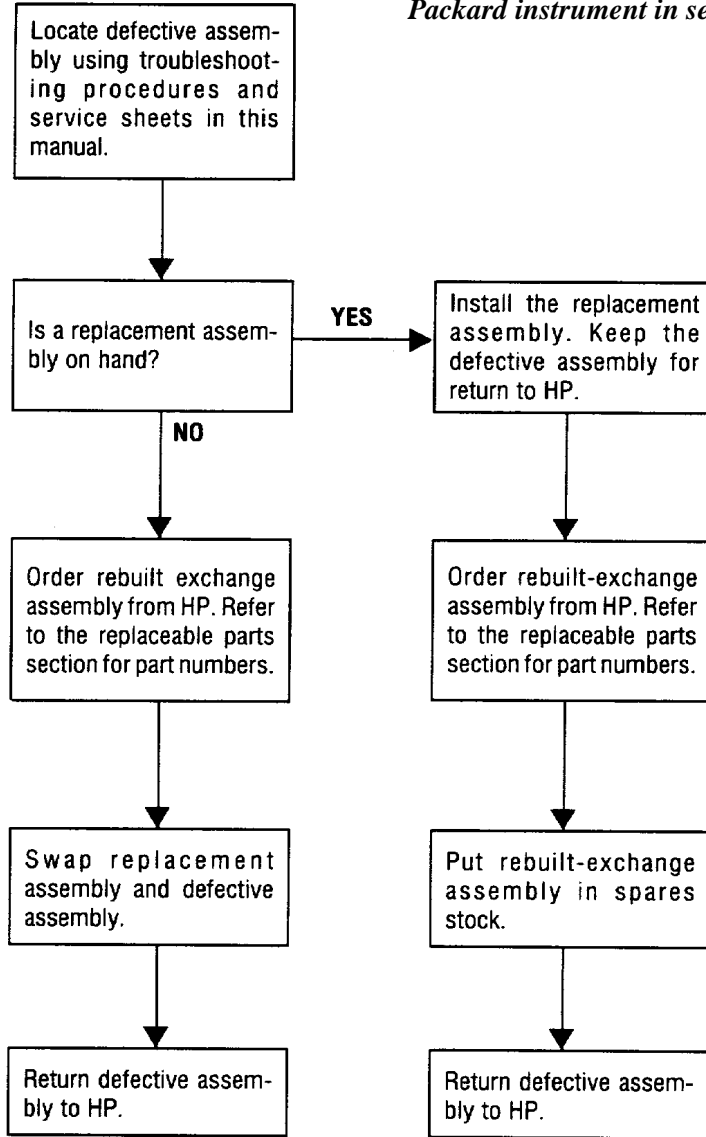

Rebuilt-exchange assemblies are shipped individually in boxes like this. In addition to the circuit assembly, the box contains:
Exchange assembly failure report
Return address label

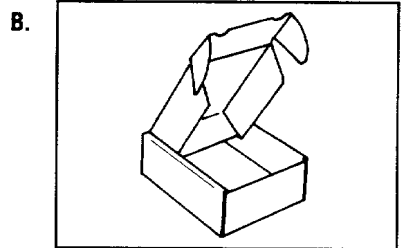

Open box carefully - it will be used to return defective assembly to HP. Complete failure report. Place it and defective assembly in box. Be sure to remove enclosed return address label.

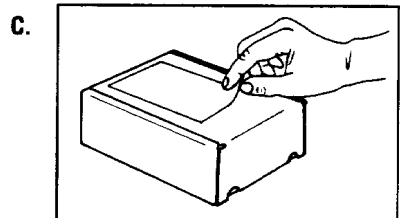

Seal box with tape. Inside U.S.A. *, stick preprinted return address label over label already on box, and return box to HP. Outside U.S.A., do not use address label; instead address box to the nearest HP office.

**Hewlett-Packard pays postage on boxes mailed in the U.S.A.*

Figure 7-2 The Low Cost Rebuilt-Exchange Procedure

Table 7-6 Major Assembly Reference Designator and Parts Information

Ref Des	HP Part Number	QTY	Description
A1	08513-60005	1	Front Panel Interface Board Assembly
A6, A8	5086-7518 5086-6518	2	50 GHz Coupler, (NEW) 50 GHz Coupler, (R-E)
A7, A9	5086-7484 5086-6484	2	Bias Tee (NEW) Bias Tee (R-E)
A16, A17	33325-60004 33325-69004	2	60 dB Step Attenuator (NEW) 60 dB Step Attenuator (R-E)
A18	5086-7570 5086-6570	1	Switch/Splitter (NEW) Switch/Splitter (R-E)
AT1, AT2	33340-60006	2	20-7 dB Tapered Pad
AT3	5063-0691	1	DC Return
A2	08513-60004 08513-69004	1	IF-MUX Used for Option 001 (NEW) See Table 7-14 IF-MUX Used for Option 001 (R-E)
A3	08517-60002 08517-69002	1	VTO Summing Amplifier Board Assembly (NEW) VTO Summing Amplifier Board Assembly (R-E)
A4	08517-60003	1	HP-IB Board Assembly (NEW)
A5	08517-60001	1	Attenuator/Switch Driver Board Assembly
A10, A11, A12, and A13	5086-6501	4	Frequency Converter Assembly
A14	5086-7501 5086-6501	1	Frequency Converter 50 GHz (Samplers and VTO) (NEW) Frequency Converter 50 GHz (Samplers and VTO) (R-E)
A15	08516-60002	1	Regulator Board Assembly
A19	08513-60001	1	Motherboard Assembly
A20	08513-60006	1	HP-IB Interface Board Assembly
A27	08517-60044	1	Post Regulator Board Assembly
B1	08513-20031	1	Fan-TBAX 34-CFM 115 V 50/60 Hz 1.5kV DIEL
T1	9100-4723	1	Power Transformer

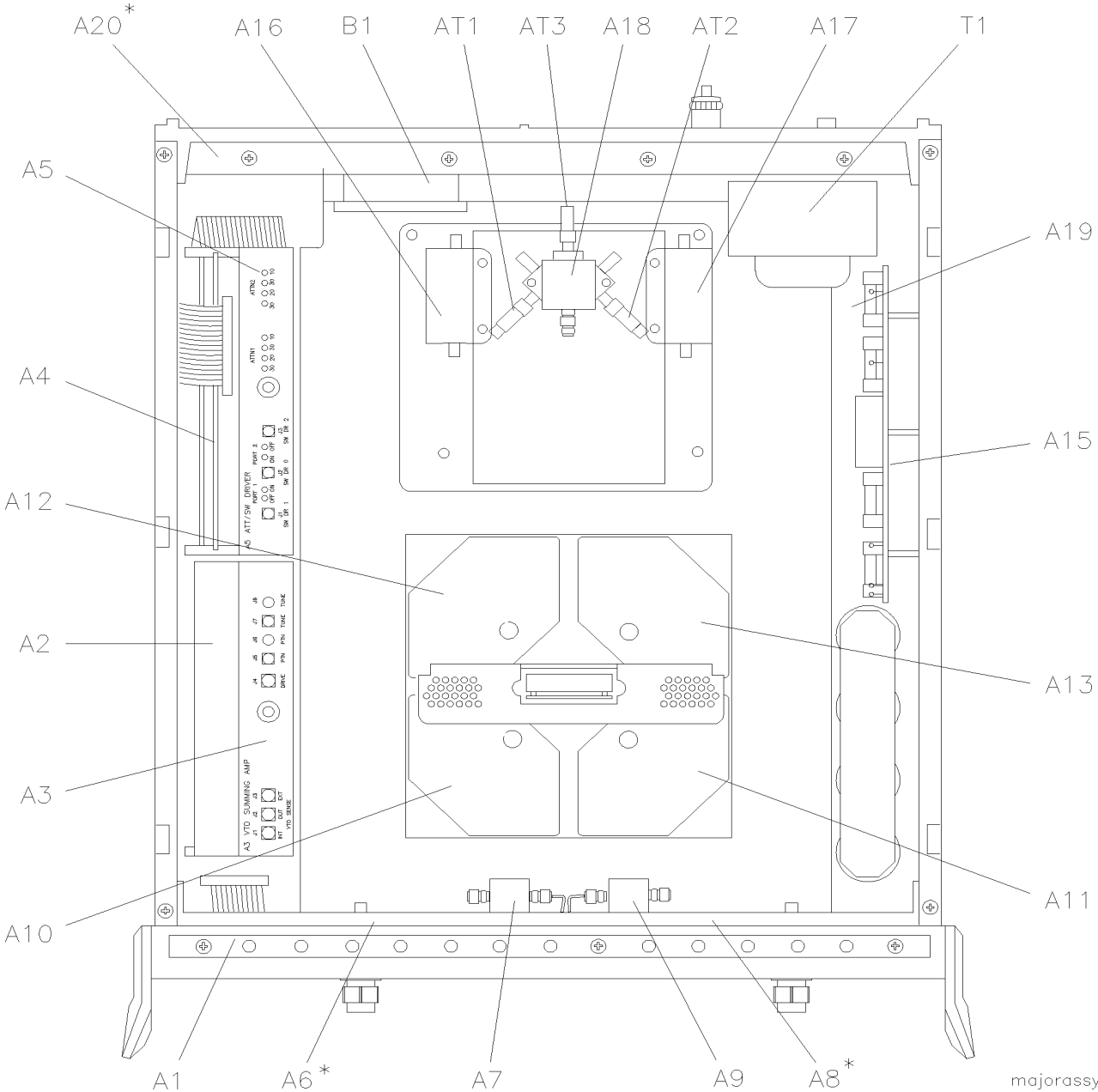

majorassy

* Not Visible

Figure 7-3 Major Assembly Locations in the Standard HP 8517B Test Set

Table 7-7 Semi-Rigid Cable Assemblies in the Standard HP 8517B Test Set

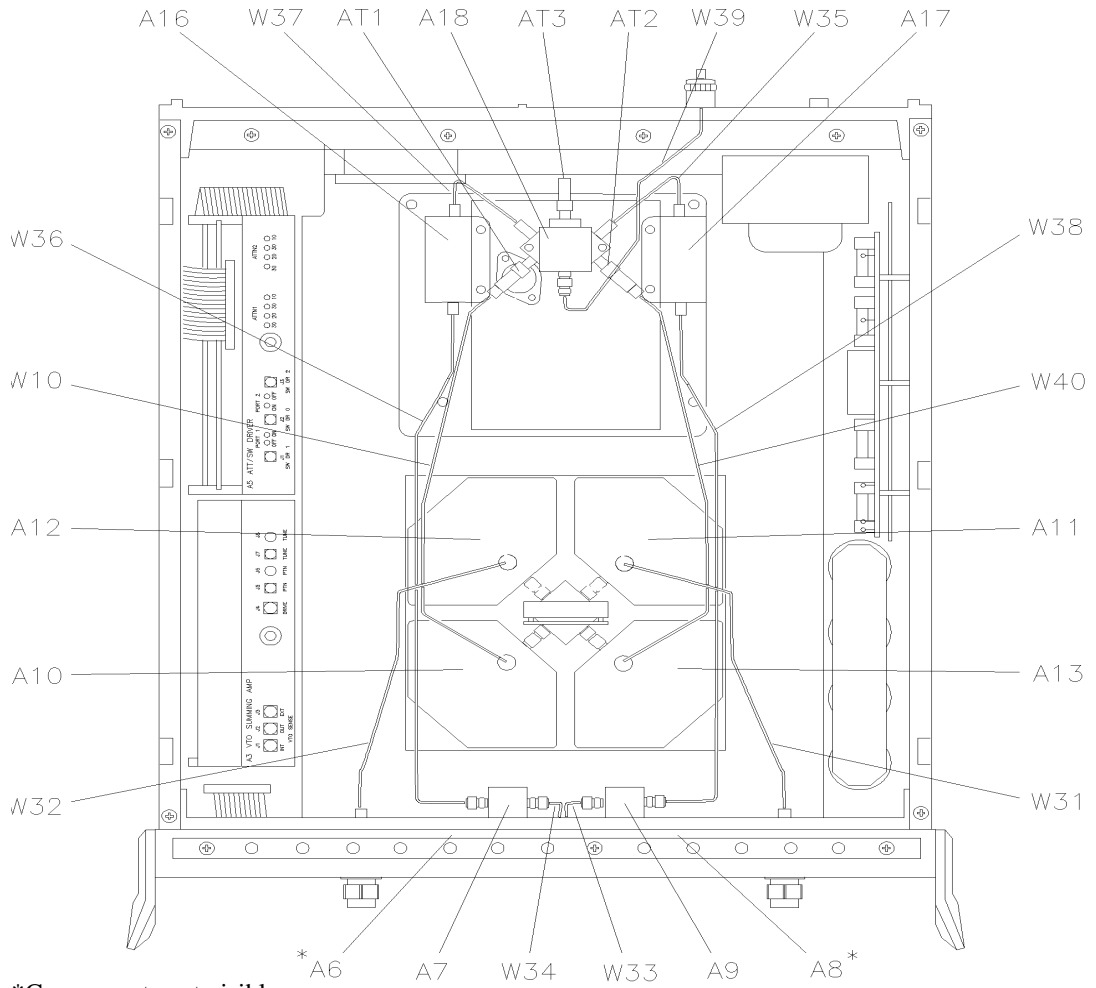

*Components not visible

semirigid

Ref Des	HP Part Number	Quantity	Description
W10	08517-20039	1	Cable Assembly AT1 to A10J2
W31	08517-20042	1	Cable Assembly A8J3 to A11J2
W32	08517-20041	1	Cable Assembly A6J3 to A12J2
W33	08517-20038	1	Cable Assembly A8J2 to A9J2
W34	08517-20038	1	Cable Assembly A6J2 to A7J2
W35	08517-20028	1	Cable Assembly A17J2 to A18J7
W36	08517-20031	1	Cable Assembly A7J1 to A16J1
W37	08517-20027	1	Cable Assembly A16J2 to A18J1
W38	08517-20032	1	Cable Assembly A9J1 to A17J1
W39	08517-20056	1	Cable Assembly AT3 to Rear Panel J7
W40	08517-20040	1	Cable Assembly AT2 to A13J2

Table 7-8 Flexible Cable Assemblies in the Standard HP 8517B Test Set

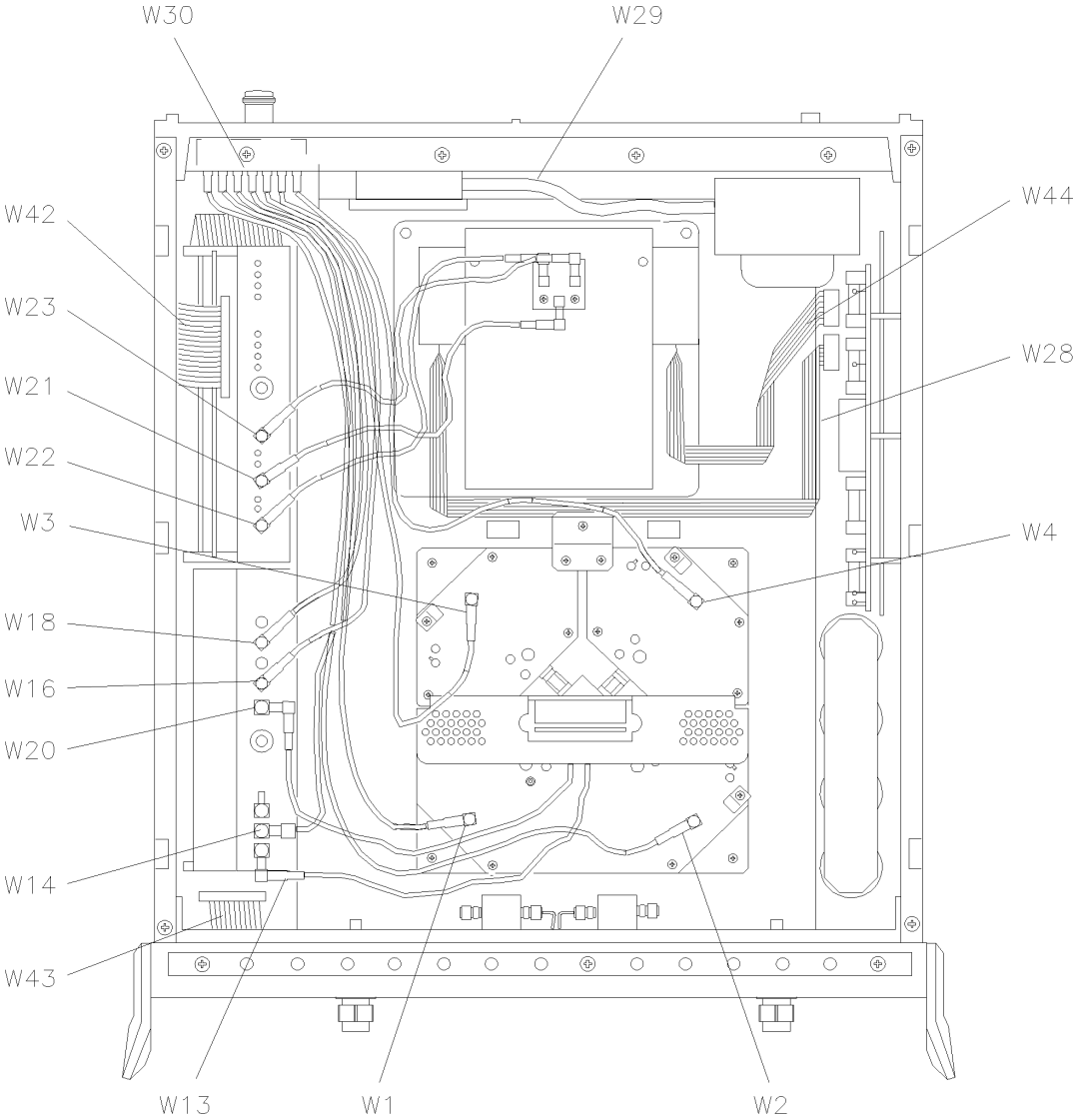

flex

Ref Des	HP Part Number	Quantity	Description
W1	08513-60121	1	Cable Assembly A12J3 to A1J11
W2	08513-60122	1	Cable Assembly A13J3 to A4J11
W3	08513-60123	1	Cable Assembly A10J3 to A2J11
W4	08513-60124	1	Cable Assembly A11J3 to A3J11
W13	08513-60133	1	Cable Assembly A3J1 to A14J1
W14	08513-60134	1	Cable Assembly A3J2 to A7J11
W16	08513-60136	1	Cable Assembly A3J5 to A5J11
W18	08513-60138	1	Cable Assembly A3J7 to A6J11

Table 7-8 Flexible Cable Assemblies in the Standard HP 8517B Test Set (Continued)

W20	08513-60140	1	Cable Assembly A3J4 to A14J2
W21	08513-60141	1	Cable Assembly A5J2 to A18J4
W22	08513-60142	1	Cable Assembly A5J1 to A18J3
W23	08513-60143	1	Cable Assembly A5J3 to A18J6
W28	08517-60014	1	Ribbon Cable Assembly A16 through A19
W29	85102-60226	1	Cable Assembly Line Switch
W30	08513-60014	1	Cable Assembly J10 to J11
W42	08513-60036	1	Cable Assembly A4 to A20
W43	08513-60013	1	Cable Assembly A1 to A19
W44	08517-60015	1	Cable Assembly A17 through A19

Table 7-9 Miscellaneous Parts, Front Panel HP 8517B Test Set

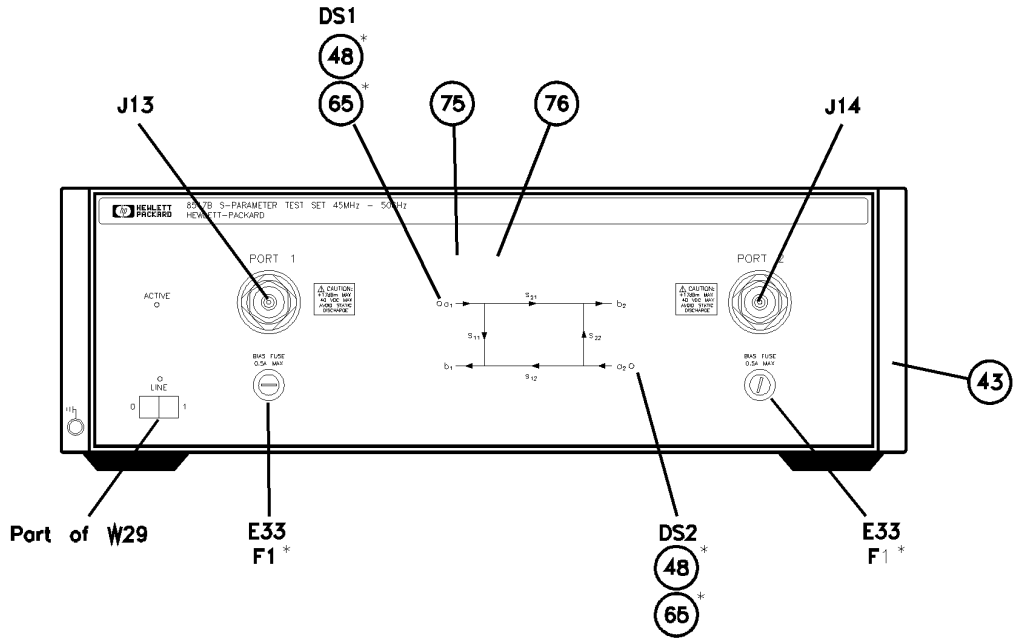

fpparts

Ref Des	HP Part Number	Quantity	Description
DS1,DS2	1990-0858	2	LED Lamp 25 MA, Maximum
E33,E34	2110-0797	2	Fuse Holder
F1,F2	2110-0012	2	Fuse 0.5 A 250 V
J13,J14 ¹	-	1 ea	See Table 7-10
43	5021-8747	1	Front Bezel
48	1450-0615	2	Retainer LED
65	08340-40002	2	Mount LED
75	08517-00002	1	Front Dress Panel
76	08517-00003	1	Front Sub-Panel

1. See Table 7-10 for parts detail.

Table 7-10 Test Port Connector Assembly Components

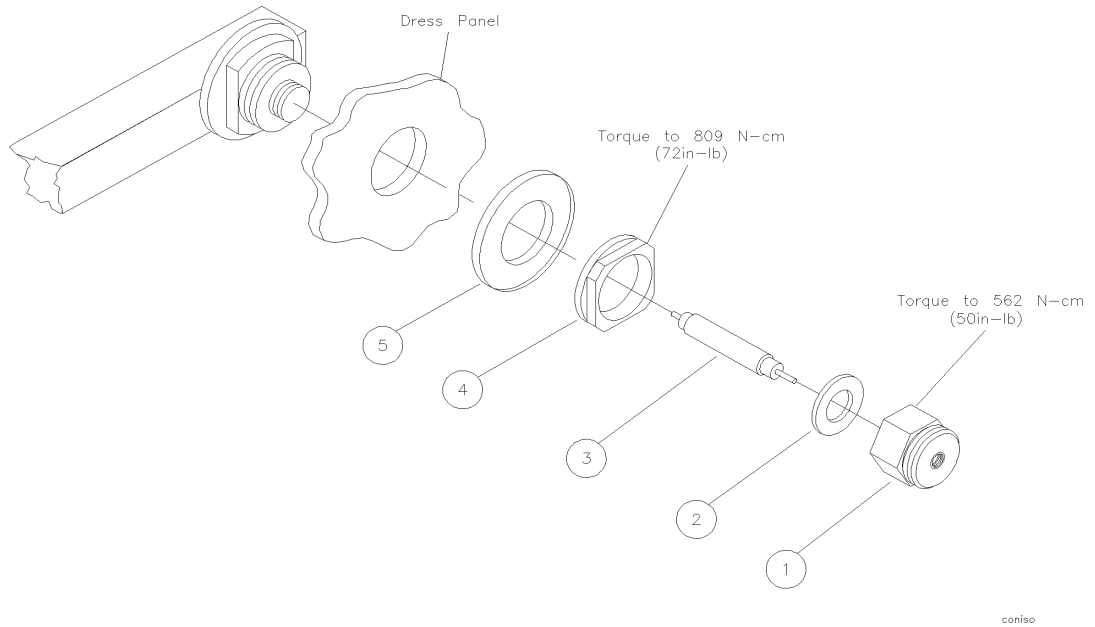

Item	HP Part Number	Quantity	Description
1	5062-7274	1	Test Port Connector
2	5001-3930 5001-3904 5001-3905 5001-3906		.0002 IN SHIM .0005 IN SHIM .001 IN SHIM .002 IN SHIM
3	5062-7276	1	Test Port Center Conductor
4	5021-3428	2	Test Port Connector Nut
5	5021-3427	2	Test Port Washer

Table 7-11 Miscellaneous Parts, Rear Panel HP 8517B Test Set

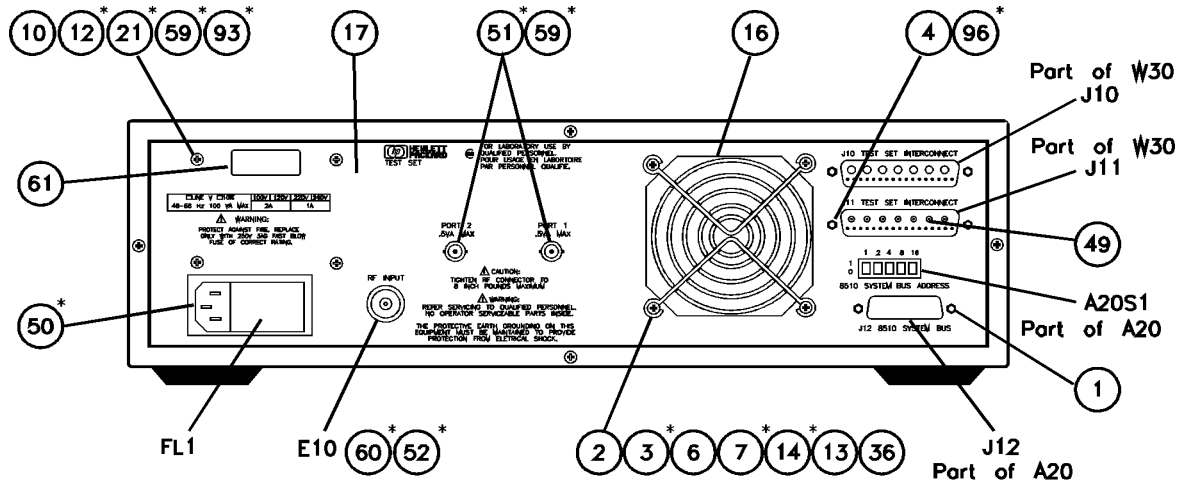

rpparts

* Not Visible

Ref Des	HP Part Number	Quantity	Description
E10	5062-7243	1	2.4 mm RF Connector Assembly
FL1	9135-0217	1	Line Module-Filtered
J10	1251-2197	1	Connector R&P 24F (Part of W30)
J11	1251-2204	1	Connector R&P 24M (Part of W30)
1	0380-0643	2	Standoff-Hex 0.255-IN-LG 6-32 THD
2 ¹	0400-0010	4	Grommet-Round 0.188-IN-ID .312-IN-GRV-OD
3 ¹	0380-0926	4	Threaded Insert-STDF 6-32 0.188-IN-LG SST
4 ²	1251-7812	6	Connector Jackscrew
6 ¹	0380-0002	4	Screw-Mach 6-32 0.625-IN-LG PAN-HD-POZI
7 ¹	2510-0322	4	Nut-HEX-W/LKWR 6-32-THD 0.109-IN-THK
10 ³	2510-0270	4	Screw-Mach 8-32 3.25-IN-LG PAN-HD-POZI
12 ³	3050-0139	12	Washer-FL MTLC NO.8 0.172-IN-ID
13 ¹	3050-0152	4	Washer-Shoulder NO.8 0.172-IN-ID .438-IN-OD
14 ¹	3050-0227	4	Washer-FL MTLC NO.6 0.149-IN-ID
16	3160-0309	1	Finger Guard
17	08517-00001	1	Rear Panel
21 ³	2190-0017	4	Washer-LK INTL NO. 10 0.195-IN-ID
36 ¹	08513-00002	1	Transformer Bracket

Table 7-11 Miscellaneous Parts, Rear Panel HP 8517B Test Set

49	5021-0906	14	Teflon™ Cable Sleeve
50	5001-3907	2	Line Module Retainer Clips
51	2190-0016	2	Washer-LK INTL T 3/8 IN 0.377-IN-ID
52	2190-0104	1	Washer-LK INTL T 7/16 IN 0.439-IN-ID
59 ³	2950-0001	2	Nut-HEX-DBL-CHAM 3/8-32-THD 0.094-IN-THK
60	2950-0132	1	Nut-HEX-DBL-CHAM 7/16-28-THD 0.094-IN-THK
61	7121-2380	1	Serial Number Label
93 ³	08513-20032	2	Transformer Support Bracket
96 ²	0590-0663	6	Nut-HEX 4/40

1. See Figure 7-4, item 2 for detail.
2. See Figure 7-4, item 3 for detail.
3. See Figure 7-4, item 1 for detail.

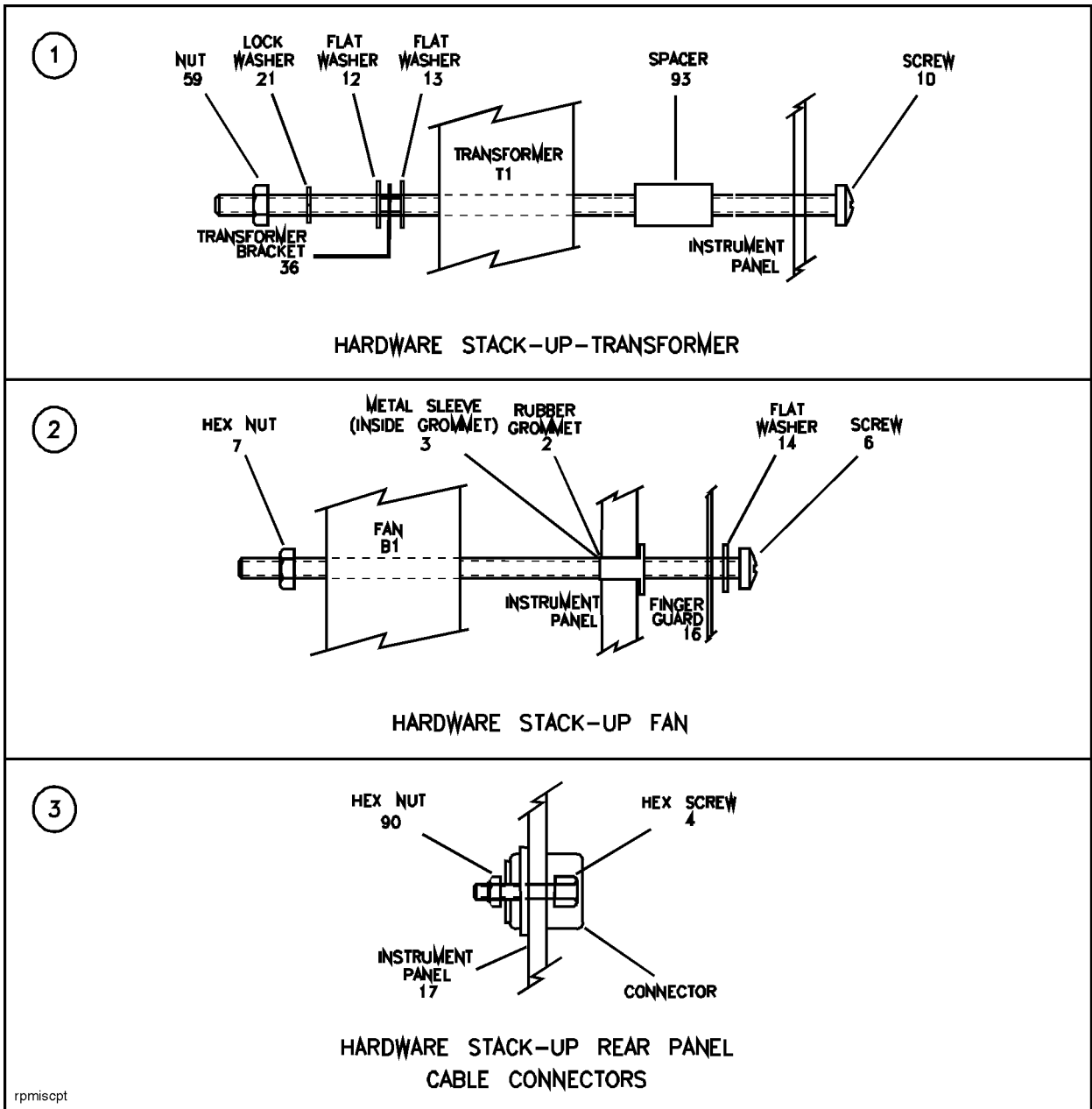
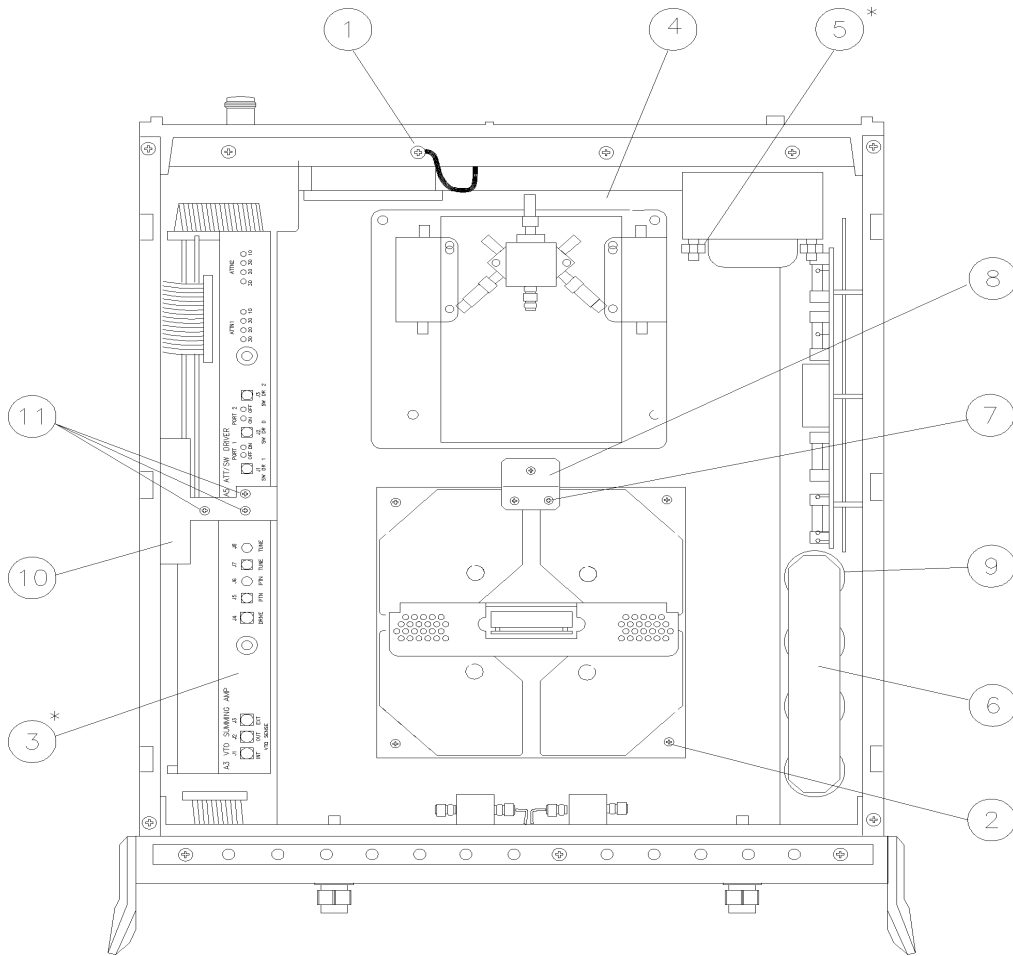

Figure 7-4 Detailed Views of Hardware Stack-Ups

Table 7-12 Miscellaneous Parts, Top Internal View



*Not Visible miscparts

Item	HP Part Number	Quantity	Description
1	0360-0031	1	Terminal Crimp
2	2360-0115	5	Machine Screw
3	08512-20005	1	RFI Gasket
4	08513-00001	1	Top Deck
5	08513-00002	1	Transformer Bracket
6	08513-00015	1	Capacitor Plate
7	2200-0109	2	Machine Screw
8	08514-00007	1	Mounting Plate
9	See Table 7-13 for all part numbers and locations	-	C1 through C4 and R1 through R4
10	0513-00037	1	Enclosure Bracket

Table 7-12 Miscellaneous Parts, Top Internal View

11	2200-0107	3	Machine Screws
----	-----------	---	----------------

Table 7-13 Miscellaneous Parts, Motherboard

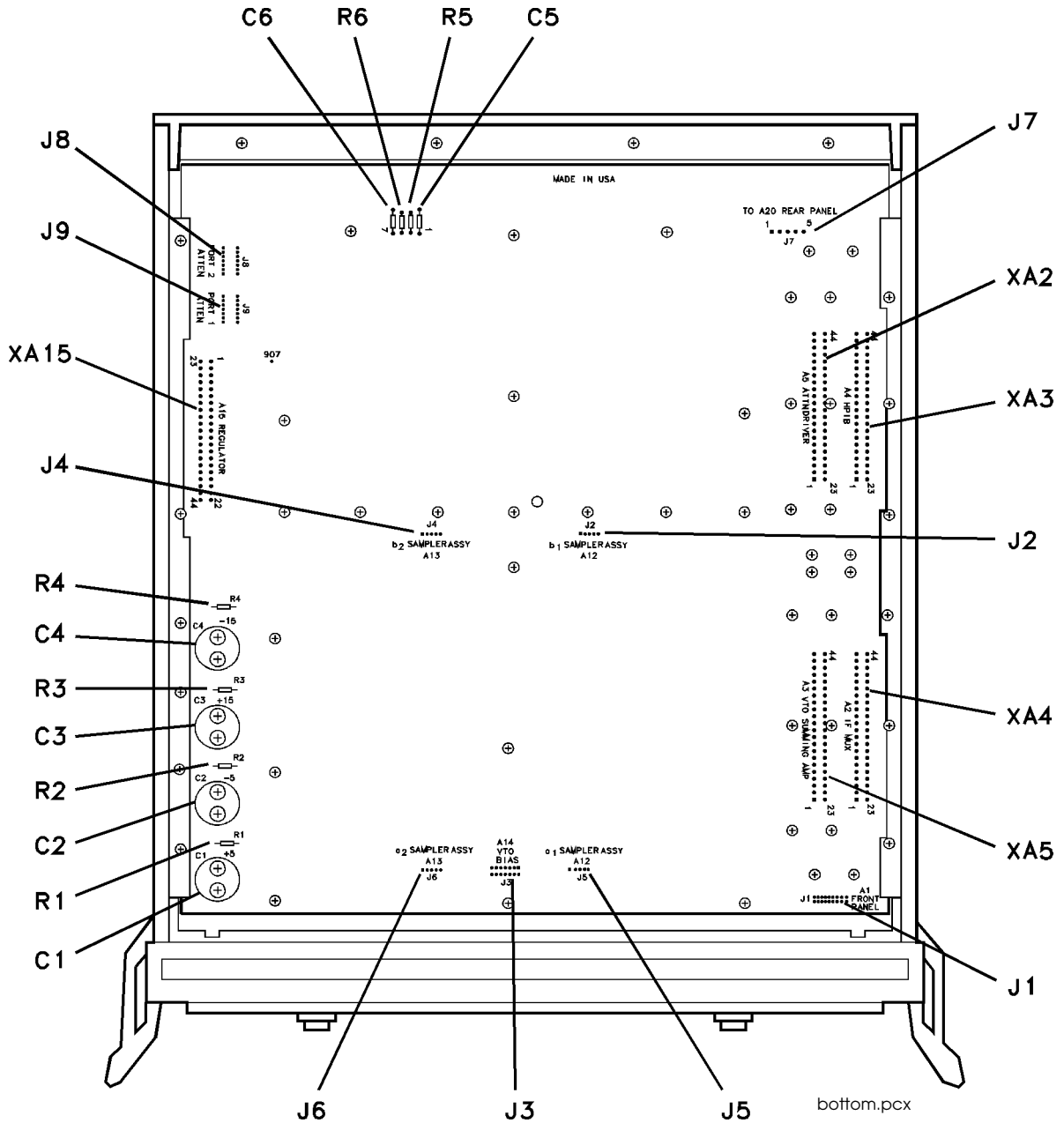

Ref Des	HP Part Number	Quantity	Description	Manufacturer Code	Manufacturer Part Number
C1 - C4	0180-2671	4	Capacitor-FXD .012F+75-10% 30VDC AL	00853	500123U030AC2A

Table 7-13 Miscellaneous Parts, Motherboard (Continued)

Ref Des	HP Part Number	Quantity	Description	Manufacturer Code	Manufacturer Part Number
C5 - C6	0160-4834	2	Capacitor-FXD .047 μ F \pm 10% 100VDC CER		
J1	1251-574		Connector 20-PIN M Post Type (A19J1) DOES NOT INCLUDE A19MP1 and A19MP2		
J2	1251-6868	4	Connector 5-PIN M Post Type		
J3	1251-7939	1	Connector - Post Type 0.100-PIN-SPCG 14-CONT (A19J3 DOES NOT INCLUDE A19MP3)		
J4, J5, and J6	1251-6868		Connector 5-PIN M Post Type		
J7	1251-3825	1	Connector 5-PIN M Post Type		
J8 and J9	1200-0508	1 ea.	Socket - IC 14-CONT DIP-SLDR		
R1 and R2	0764-0015	1 ea.	Resistor 560 Ω 5% 2W MO TC = 0 \pm 200		
R3 and R4	0764-0016	1 ea.	Resistor 1 k Ω 5% 2W MO TC = 0 \pm 200		
R5 and R6	0757-0394	1 ea.	Resistor 51.1 Ω 1% 0.125W F TC = 0 \pm 100	24546	C4-1/8-T0-51R1-F
XA2, XA3, XA4, and XA5	1251-7882	1 ea.	Connector-PC Edge 2-Rows		
XA6 to XA14			Not Assigned		
XA15	1251-7882	1	Connector-PC Edge 2-Rows		

Table 7-14 Parts Unique to HP 8517B Option 001 Test Set

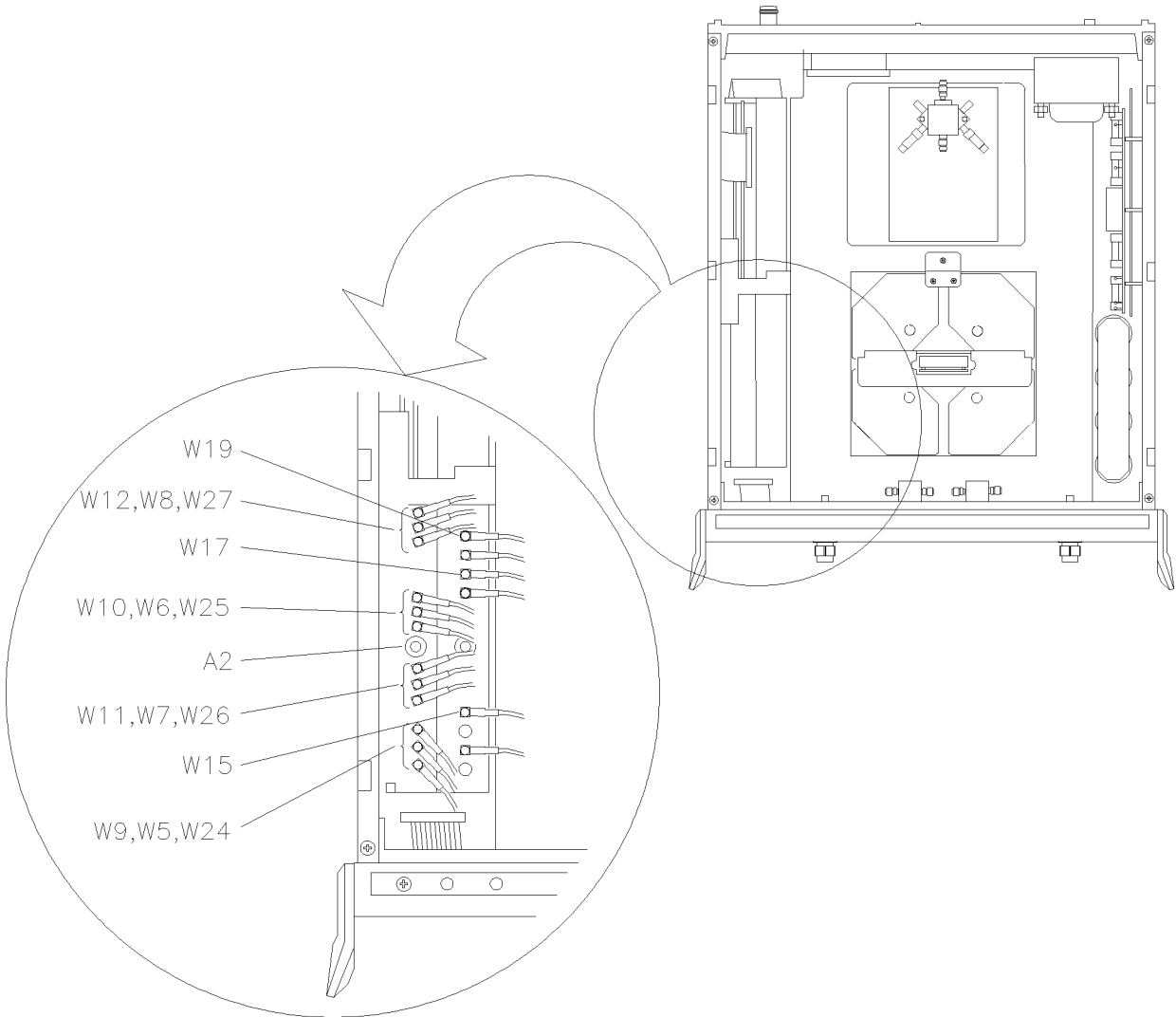

uniqueparts

Ref Des	HP Part Number	Quantity	Description
A2	08513-60004	1	Board Assembly, IF Multiplexer (NEW)
	08513-69004		Board Assembly, IF Multiplexer (R-E)
Cable Assemblies Unique to Option 001			
W5	08513-60125	1	Cable Assembly, A2J2 to J11A1
W6	08513-60126	1	Cable Assembly, A2J8 to J11A4
W7	08513-60127	1	Cable Assembly, A2J5 to J11A2
W8	08513-60128	1	Cable Assembly, A2J11 to J11A3
W9	08513-60129	1	Cable Assembly, A2J3 to J10A1

Table 7-14 Parts Unique to HP 8517B Option 001 Test Set

Ref Des	HP Part Number	Quantity	Description
W10	08513-60130	1	Cable Assembly, A2J9 to J10A4
W11	08513-60131	1	Cable Assembly, A2J6 to J10A2
W12	08513-60132	1	Cable Assembly, A2J12 to J10A3
W15	08513-60135	1	Cable Assembly, A3J3 to J10A7
W17	08513-60137		Cable Assembly, A3J6 to J10A5
W19	08513-60139	1	Cable Assembly, A3J8 to J10A6
W24	08513-60144	1	Cable Assembly, A12J3 to A2J1
W25	08513-60145	1	Cable Assembly, A13J3 to A2J7
W26	08513-60146	1	Cable Assembly, A10J3 to A2J4
W27	08513-60147	1	Cable Assembly, A11J3 to A2J10
W45	08517-20017	1	Cable Assembly, A8 to A18
W46	08517-20018	1	Cable Assembly, A6 to A18

Table 7-15 Parts Unique to HP 8417B Option 002 Test Set

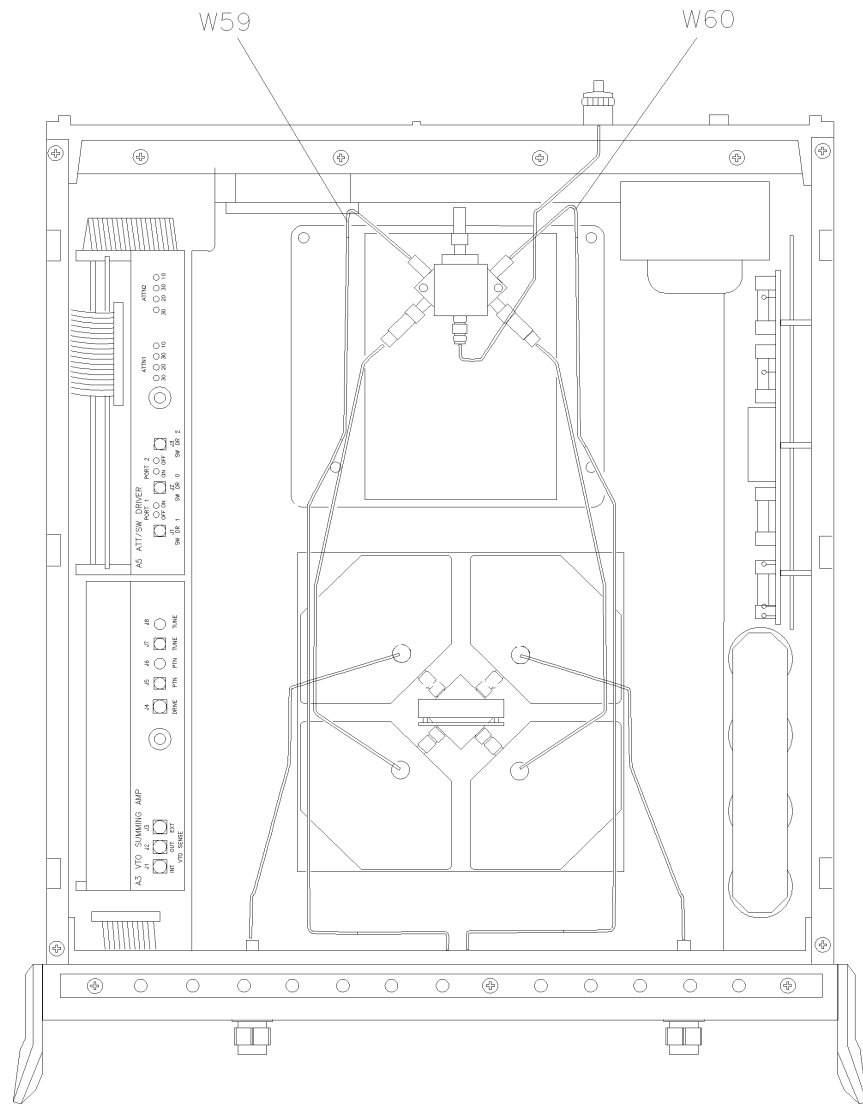

opt002

Ref Des	HP Part Number	Quantity	Description
W59	08517-20743	1	Cable Assembly, A12J3 to Port 1 J13
W60	08517-20737	1	Cable Assembly, A13J3 to Port 2J14

Table 7-16 Parts Unique to HP 8517B Option 004 Test Set

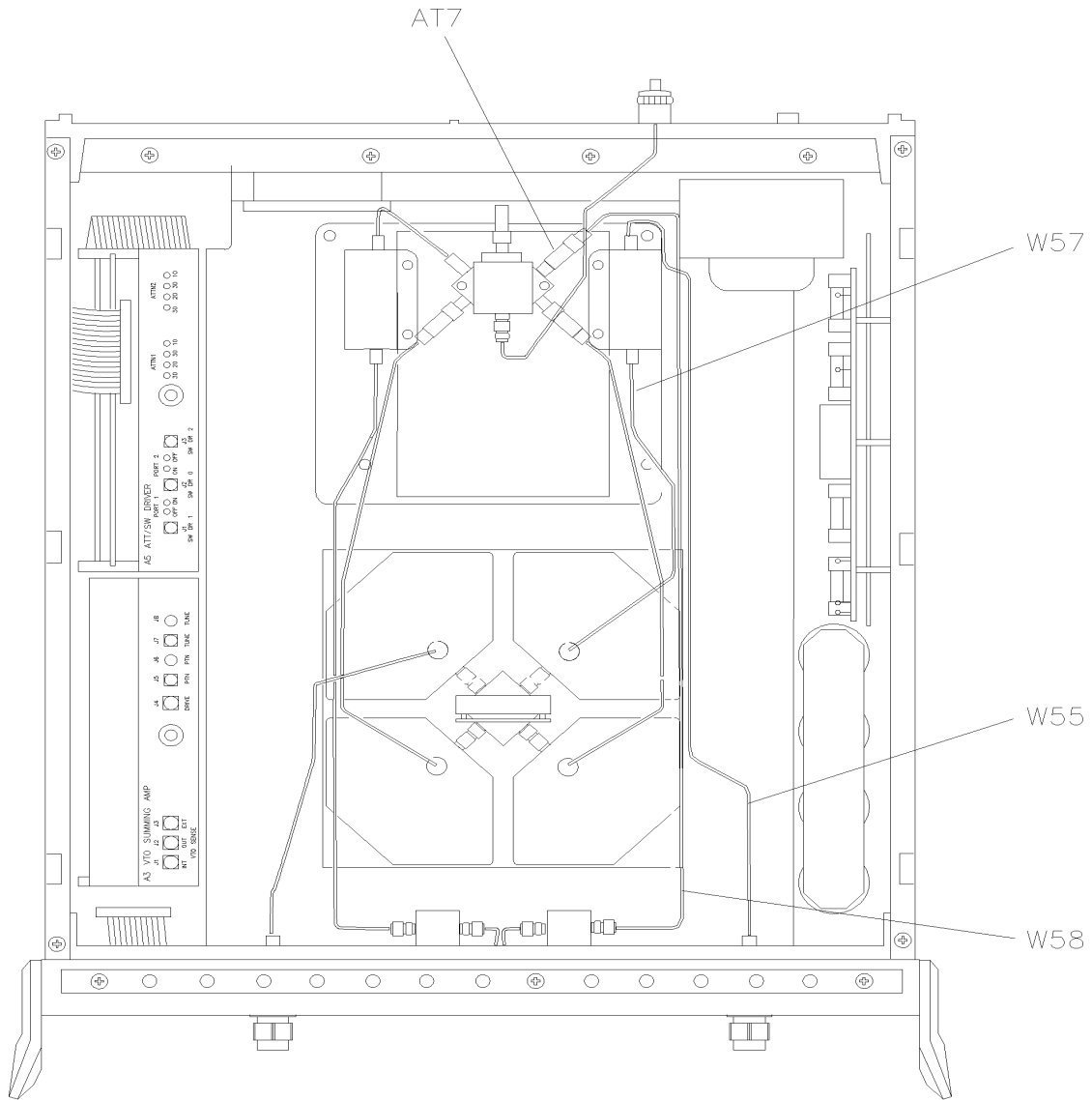

opt004

Ref Des	HP Part Number	Quantity	Description
W55	08517-20051	1	Cable Assembly, AT7 to A9J1
W57	08517-20052	1	Cable Assembly, A8J3 to A17J2
W58	08517-20050	1	Cable Assembly, A17J1 to A11J2
AT7	08517-60020	1	3 dB Attenuator

Table 7-17 Parts Unique to HP 8517B Option 007 Test Set

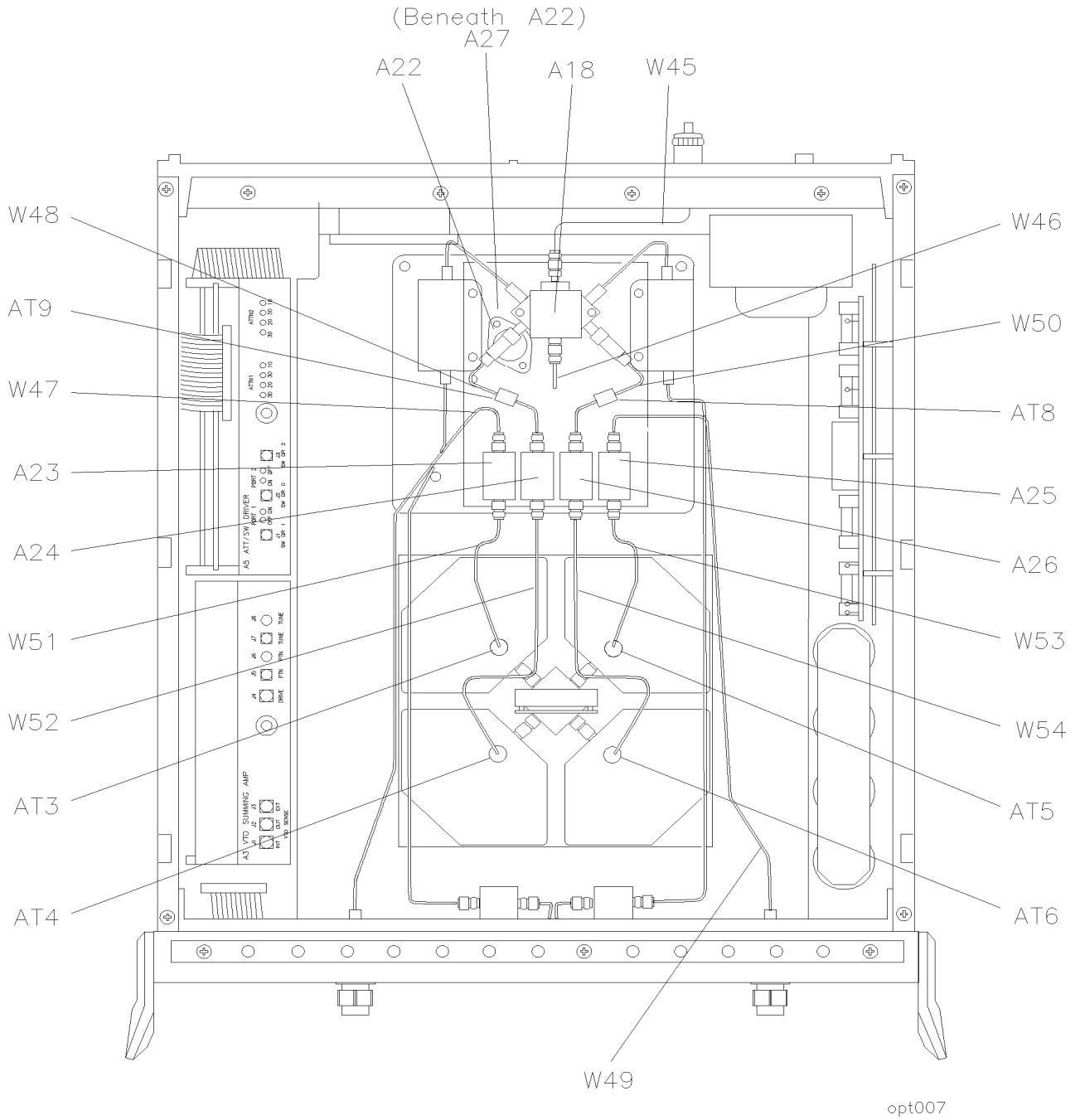

Ref Des	HP Part Number	Quantity	Description
AT8 and AT9	08516-60021	2	3 dB Attenuators
A22	5086-7650	1	Input Amplifier
A23, A24, A25, and A26	5086-7649	4	Buffer Amplifiers
A27	08517-60045	1	Post Regulator Board Assembly (Beneath A22 Input Amplifier)

Table 7-17 Parts Unique to HP 8517B Option 007 Test Set (Continued)

Ref Des	HP Part Number	Quantity	Description
Cable Assemblies Unique to Option 007			
W45	08517-20023	1	Front Panel J7 to A22 Input Amplifier
W46	08517-20024	1	A22 Input Amplifier to A18J5
W47	08517-2003	1	A6 Coupler to A23
W48	08517-20061	1	AT1 to A24
W49	08517-20036	1	A8 Coupler to A25
W50	08517-20062	1	AT2 to A26
W51	08517-20034	1	A23 to AT3
W52	08517-20029	1	A24 to AT4
W53	08517-20034	1	A25 to AT5
W54	08517-20030	1	AT6 to A26
AT3	33340-60004	1	13 dB to 5 dB Attenuator
AT4	08516-60004	1	10 dB Attenuator
AT5	33340-60004	1	13 dB to 5 dB Attenuator
AT6	08516-60007	1	10 dB Attenuator

Table 7-18 Parts Unique to Option 002 “plus” Option 007

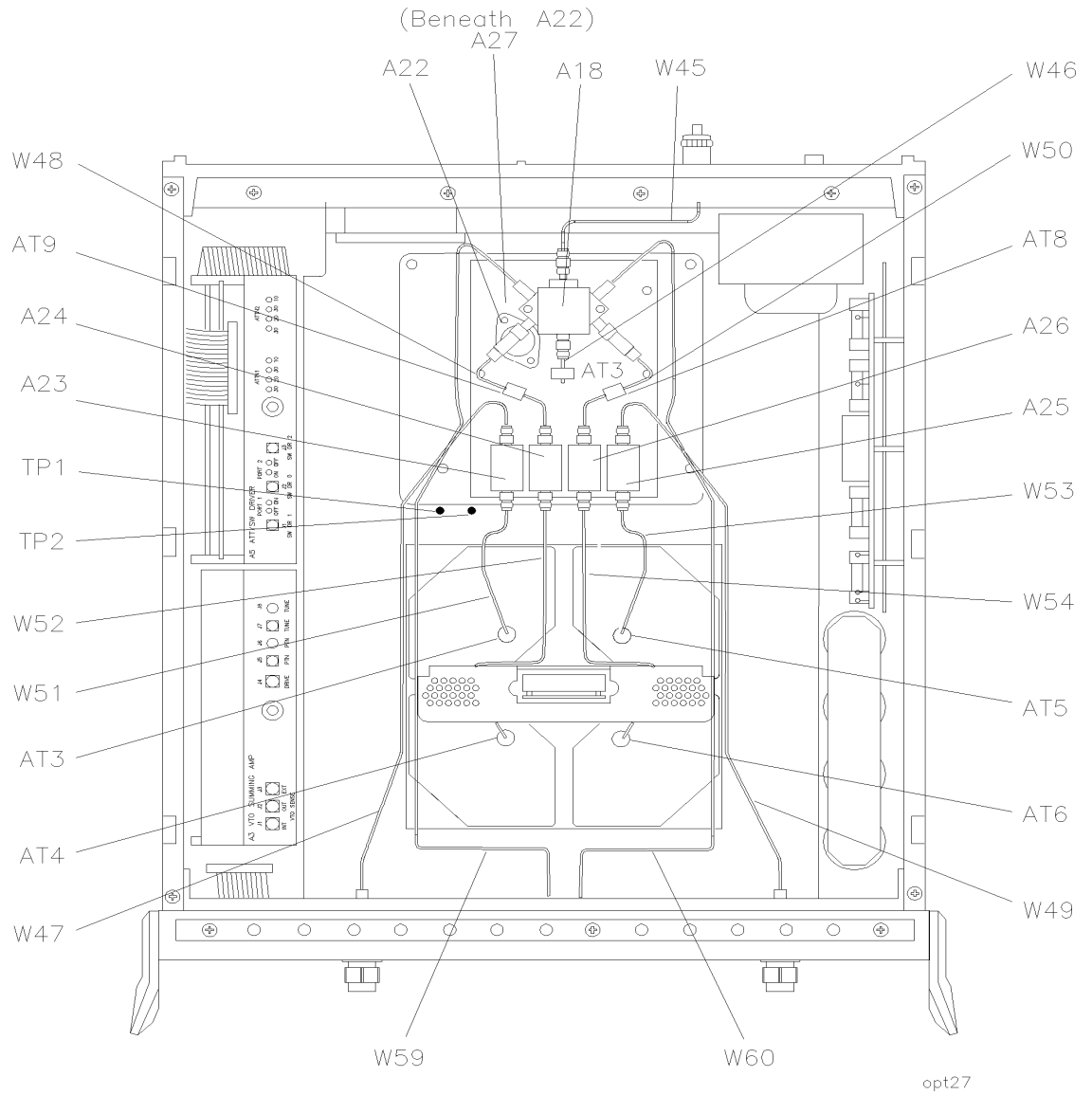

There are no unique parts to Option 002 “plus” Option 007. All other parts are included in Option 002 or Option 007.

Table 7-19 Parts Unique to Option 004 “plus” Option 007

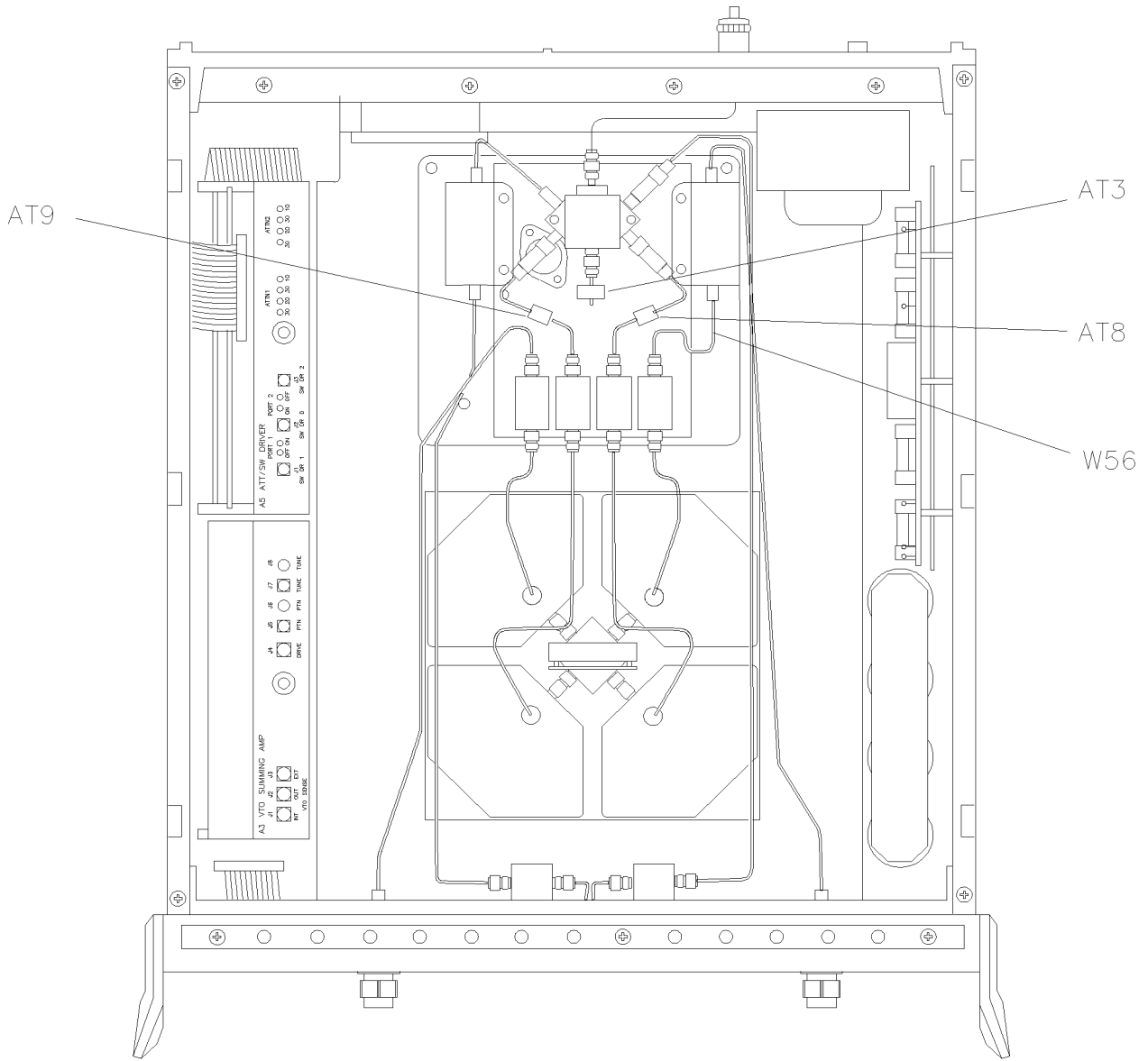

opt4&7

Ref Des	HP Part Number	Quantity	Description
W56	08517-20049	1	A17J1 to A25

All other parts are included in Option 004 or Option 007.

Table 7-20 Instrument Chassis Replaceable Parts

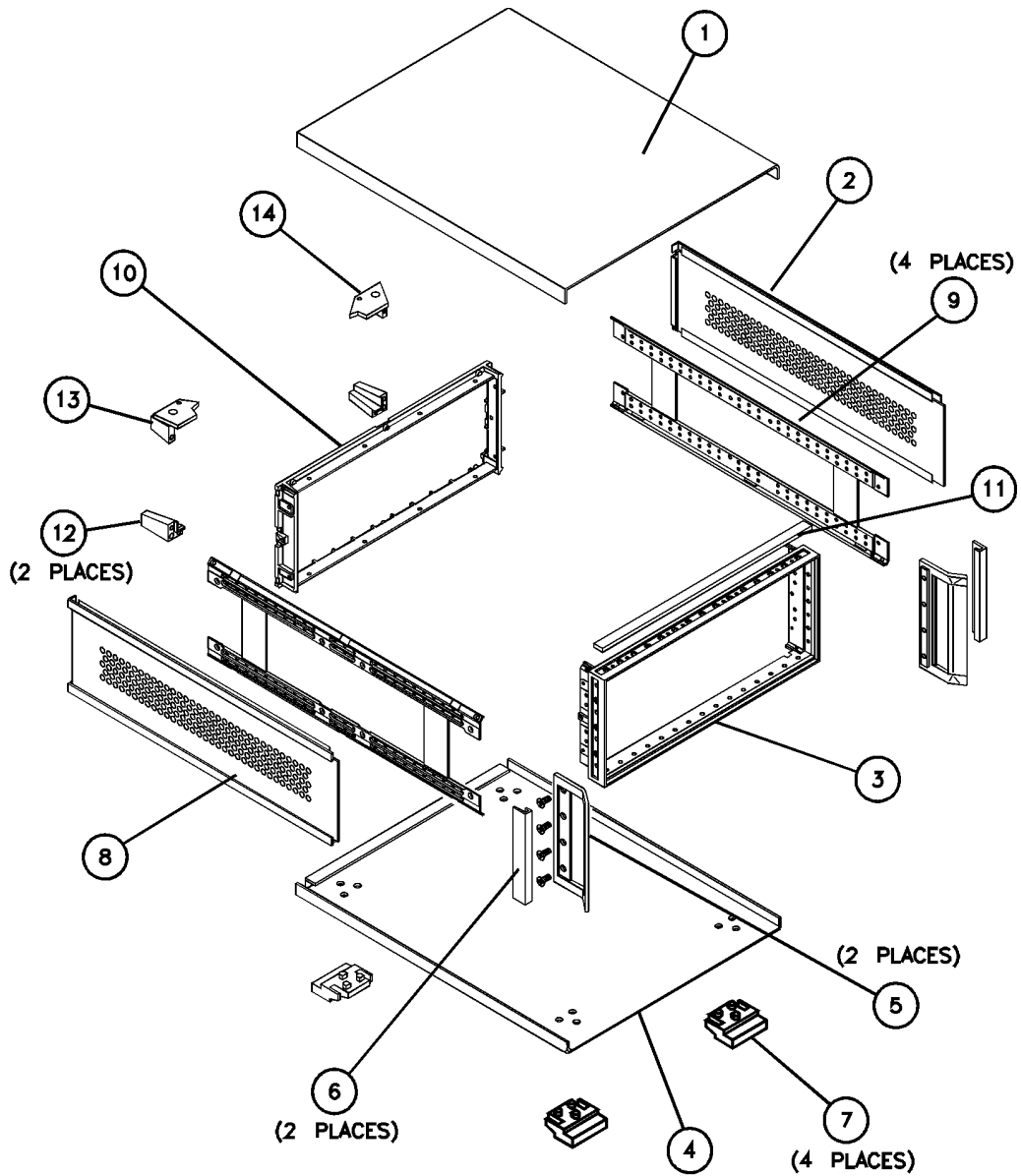

chassis

Item Number	HP Part Number	Quantity	Description
1	08513-00040	1	Top Cover
2	08513-00041	1	Side Cover, Perforated
3	5021-8403	1	Front Frame
4	5062-3747	1	Bottom Cover
5	5062-3799	1	Handle Assembly
6	5021-8496	1	Trim, Front Handle

Table 7-20 Instrument Chassis Replaceable Parts (Continued)

Item Number	HP Part Number	Quantity	Description
7	5041-8821	4	Bottom Foot
8	5062-3757	1	Side Cover
9	5021-5837	1	18-inch Corner Strut
10	5021-5804	1	Rear Frame
11	5041-8802	1	Trim Strip
12	5041-8821	2	Back Panel Foot
13	5021-8538	1	Lock Foot
14	5021-8540	1	Lock Foot

Index

A

- abbreviations used in parts descriptions, 7-4
- accessories descriptions, 2-3
- active LED location, 3-1
- adapter part numbers, 1-11
- addressing a test set, 3-6
- altering signal path conditions, 3-10
- attaching anti-rotation clamps, 3-15

B

- bias supply connector, 3-3
- bias tees replacement, 6-11
- bias tees usage, 1-2
- block diagram, Option 004 HP 8517B, 1-3
- block diagram, Option 007 HP 8517B, 1-3
- block diagram, standard HP 8517B, 1-2
- buffer amplifier replacement, 6-12

C

- cable assemblies, flexible, 7-17
- cable assemblies, semi-rigid, 7-16
- cable descriptions and part numbers, 1-10
- cabling the test set, 2-5
- calibration cycle frequency, 1-6
- calibration kit part number, 1-10
- calibration procedure, 3-8
- capacitor (filter capacitor) replacement, 6-6
- CAUTION: CORRECTION MAY BE INVALID, 3-10
- characteristics, 4-1, 4-2
- characteristics of test set, 4-1
- checking test set operation, 3-13
- checking test-system operation, 1-5
- checking test-system specifications, 1-5
- choosing a test set from multiple test sets, 3-6
- commands, switch driver, 3-6
- configuration, 2-5
- connection instructions, 2-6
- connector-type descriptions, 2-6

D

- definitions of prefixes used, 7-10
- description of test set, 1-2

E

- environmental requirements, 2-2
- equipment requirements for replacing components, 6-3
- ESD information, 6-1
- ESD precaution, 1-13

F

- fan assembly replacement, 6-8
- features, front panel, 3-1
- firmware compatibility matrix, 1-8
- fixture kit part number, 1-11
- frequency converter replacement, 6-5
- front panel boards replacement, 6-10
- front panel test ports, 4-1
- front-panel parts ID, 7-19
- fuse part numbers, 7-12

H

- hardware stacking sequence, 7-23
- high-power device measurement, 3-9

I

- IF switching in the test set, 3-6
- initializing a test set, 3-5
- input amplifier replacement, 6-12
- installing anti-rotation clamps, 3-15

J

- J10 and J10 interconnect locations, 3-2

L

- LED descriptions, 3-2
- line module location, 3-2

M

- manufacturer addresses (other than HP), 7-3
- measurement accuracy maintenance, 1-6
- measurement capabilities, 1-2
- mechanical specifications, test set, 4-1
- multiple test set configuration, 3-3, 3-7

N

- network analyzer compatibility matrix, 1-8
- normalizing parameters, viewing, 3-11

O

- operation precautions, 1-13
- operation verification, 1-5
- option descriptions, 1-4
- options for service and support, 1-9
- ordering information, 7-2
- O-ring replacement, 2-6, 6-10

P

- parts ID, front panel, 7-19
- parts ID, instrument chassis, 7-35
- parts ID, internal top view, 7-24
- parts ID, major assemblies, 7-15
- parts ID, motherboard, 7-25
- parts ID, rear panel, 7-21
- parts ID, test port components, 7-20
- parts ID, unique to option 002, 7-27
- parts ID, unique to option 002 "plus" 007, 7-33
- parts ID, unique to option 004, 7-30
- parts ID, unique to option 004 "plus" 007, 7-34
- parts ID, unique to option 007, 7-31
- phase lock, 4-2
- phone-ordering parts, 7-2
- physical characteristics, 4-2
- plug assembly part numbers, 7-11
- port attenuators replacement, 6-11
- post-regulator board replacement, 6-13
- power level input limits, 1-13
- power requirements, 4-2
- power transformer replacement, 6-9
- powering up, 3-5

R

- racking the test set, 2-4
- R-E (rebuilt exchange assemblies) defined, 7-1
- R-E process, 7-13
- rear panel RF connector, 4-2
- rear-panel parts ID, 7-21
- reference channel phase lock power level, 4-2
- reference designation, major assemblies, 7-14
- reference designator abbreviations, 7-2
- regulator board replacement, 6-6
- replacement procedure basics, 6-5
- revision information, 1-8
- RF input damage level, 4-2

S

- safety precautions, 1-13
- sales and service internet address, vi
- sales and service office locations, vi
- selecting a test set, 3-5
- serial prefix location and description, 1-7
- service and support options, 1-9
- shipping the test set, 2-7
- source compatibility matrix, 1-8
- static discharge precautions, 6-1
- storage temperature, 2-2
- switch/splitter replacement, 6-5
- switch-driver control, 3-6

T

- temperature and humidity requirements, 2-2
- test equipment model requirements, 1-12
- test port attenuator modifications, 3-10
- test port characteristics, 4-1
- test port couplers replacement, 6-11
- test set, 4-2
- test set accessories identification, 2-3
- test set adapters, 1-11
- test set connections, for two or more, 3-5
- test set options, 1-4
- test set specifications, 4-1
- test set switching, two test sets, 3-4
- test set test-fixture kit, 1-11
- test set troubleshooting, 1-5
- test-port connector replacement, 6-7
- test-port parts ID, 7-20
- trace memory storage, 3-11

U

- user 1 power levels for reference channel, 4-2
- using bias tees, 1-2
- using multiple test-set configurations, 3-5
- using the test set at a bench, 2-4

V

- verification kit part number, 1-10
- verifying test set performance, 3-14
- viewing S11 to S22 parameters, 3-12

W

- what to do with damaged shipments, 2-2