

English

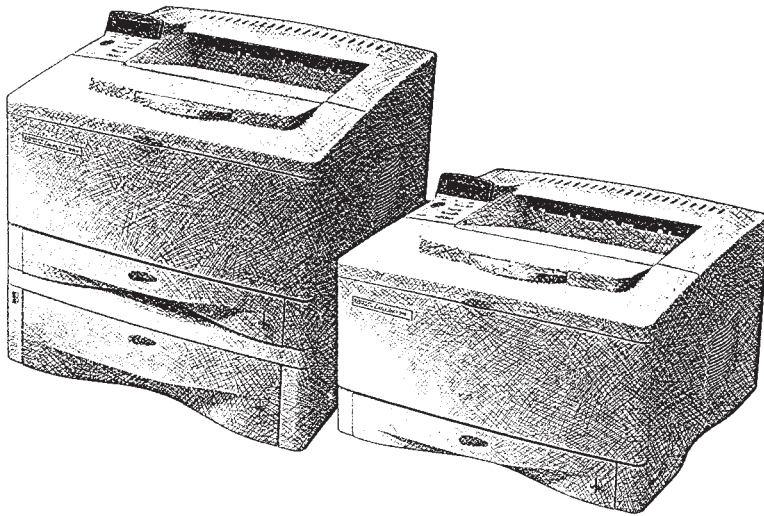

HP LaserJet 5000, 5000 N,
and 5000 GN Printers
User's Guide

HP LaserJet 5000, 5000 N, and 5000 GN Printers

User's Guide

© Copyright Hewlett-Packard
Company 1998

All Rights Reserved.
Reproduction, adaptation, or
translation without prior written
permission is prohibited,
except as allowed under the
copyright laws.

Publication number
C4110-90901

First Edition, May 1998

Warranty

The information contained in
this document is subject to
change without notice.

Hewlett-Packard makes no
warranty of any kind with
respect to this information.
HEWLETT-PACKARD
SPECIFICALLY DISCLAIMS
THE IMPLIED WARRANTY
OF MERCHANTABILITY AND
FITNESS FOR A
PARTICULAR PURPOSE.

Hewlett-Packard shall not be
liable for any direct, indirect,
incidental, consequential, or
other damage alleged in
connection with the furnishing
or use of this information.

Trademark Credits

Adobe, PostScript, and Adobe
Photoshop are trademarks of
Adobe Systems Incorporated
which may be registered in
certain jurisdictions.

Arial, Monotype, and Times
New Roman are U.S.
registered trademarks of the
Monotype Corporation.

CompuServe is a U.S.
trademark of CompuServe,
Inc.

Helvetica, Palatino, Times, and
Times Roman are trademarks
of Linotype AG and/or its
subsidiaries in the U.S. and
other countries.

Microsoft, MS Windows,
Windows, and Windows NT
are U.S. registered trademarks
of Microsoft Corporation.

TrueType is a U.S. trademark of
Apple Computer, Inc.

ENERGY STAR is a U.S.
registered service mark of the
U.S. EPA.

Take a look at all that HP Support has to offer!

Thank you for your purchase. Along with your product, you receive a variety of support services from Hewlett-Packard and our support partners that are designed to give you the results you need, quickly and professionally.

HP Support

<p>Online Services: for 24-hour access to information over your modem, we suggest these services:</p>	<p>World Wide Web URL - Printer drivers, updated HP printer software, plus product and support information may be obtained from the following URLs:</p> <p>in the U.S.: http://www.hp.com</p> <p>in Europe: http://www2.hp.com</p> <p>Printer drivers may be obtained from the following sites:</p> <p>in Japan: ftp://www.jpn.hp.com/drivers/</p> <p>in Korea: http://www.hp.com.kr</p> <p>in Taiwan: http://www.hp.com.tw or from a local driver website of http://www.dds.com.tw</p>	
	<p>HP Bulletin Board Service - Our electronic download service provides convenient access to HP printer drivers, updated HP printer software, product information, and troubleshooting hints. Set your communications software to N,8,1 and dial or use:</p> <p>in the U.S. and Canada:(1) (208) 344-1691</p> <p>in Taiwan: (886) (2) 923-3233</p> <p>in Korea: HITEL or CHOLIAN (Go HPK)</p> <p>in Australia: (61) (3) 9890-0276</p> <p>in New Zealand: (64) (9) 356-3660</p> <p>in China: (86) (10) 6261-4172</p> <p>European Bulletin Board Service numbers are listed at http://www2.hp.com.</p>	
	<p>America Online - (America Online/Bertelsmann is available in France, Germany, and UK) - Printer drivers, updated HP printer software, and support documentation to help answer your questions on HP products are available. Use Keyword HP to start your tour or call (1) (800) 827-6364 and ask for representative #1118 to subscribe.</p>	
	<p>CompuServe - Printer drivers, updated HP printer software, and interactive sharing of technical information with other members is available on CompuServe's HP User's forums (GO HP), or call (1) (800) 524-3388 and ask for representative #51 to subscribe. (CompuServe is also available in the U.K., France, Belgium, Switzerland, Germany, and Austria.)</p>	
<p>Obtaining Software Utilities and Electronic Information for U.S. and Canada:</p>	<p>Phone: (1) (970) 339-7009</p>	<p>Mail: Hewlett-Packard Co. P.O. Box 1754 Greeley, CO 80632 U.S.A.</p>
	<p>Fax: (1) (970) 330-7655</p>	
<p>For Asia-Pacific Countries:</p>	<p>Contact Fulfill Plus at (65) 740-4477 (Hong Kong, Indonesia, Philippines, Malaysia, or Singapore). For Korea, call (82) (2) 3270-0805 or (82) (2) 3270-0893.</p>	
<p>For Australia, New Zealand, and India:</p>	<p>For Australia and New Zealand, call (61) (2) 565-6099. For India, call (91) (11) 682-6035.</p>	
<p>For European English:</p>	<p>For U.K., call (44) (142) 986-5511. For Ireland and outside U.K., call (44) (142) 986-5511.</p>	
<p>HP Direct Ordering for Accessories and Supplies:</p>	<p>Call (1) (800) 538-8787 (U.S.) or (1) (800) 387-8164 (Canada).</p>	
<p>HP Support Assistant compact disc:</p>	<p>This support tool offers a comprehensive online information system designed to provide technical and product information on HP products. To subscribe to this quarterly service in the U.S. or Canada, call (1) (800) 457-1762. In Hong Kong, Indonesia, Malaysia, or Singapore, call Fulfill Plus at (65) 740-4477.</p>	
<p>HP Service Information:</p>	<p>To locate HP-authorized dealers, call (1) (800) 243-9816 (U.S.) or (1) (800) 387-3867 (Canada).</p>	

HP Support (Continued)

HP Service Agreements:		Call (1) (800) 446-0522 (U.S.) or (1) (800) 268-1221 (Canada).	
HP FIRST: HP FIRST Fax will deliver detailed troubleshooting information on common software and troubleshooting tips for your HP product. Call from any touch-tone phone and request up to three documents per call. These documents will be sent to the fax of your choice.			
Australia	(61) (3) 9272-2627	Korea	(82) (2) 769-0543
Austria	(43) (1) 0660-8128	Malaysia	(60) (3) 298-2478
Belgium (Dutch)	(32) (2) 0800-11906	Netherlands	(31) (20) 0800-222420
Belgium (French)	(32) (2) 0800-17043	New Zealand	(64) (9) 356-6642
Canada	(1) (800) 333-1917	Norway	(47) 800-11319
China	(86) (10) 6505-5280	Portugal	(351) (1) 0505-313342
Denmark	(45) 8001-0453	Philippines	(65) 291-7951
English (outside of U.K.)	(31) (20) 681-5792	Singapore	(65) 275-7251
Finland	(358) (9) 0800-13134	Spain	(34) 900 993123
France	(33) (146) 0800-905900	Sweden	(46) (2) 079-5743
Germany	(49) (13) 081-0061	Switzerland (German)	(41) (1) 0800-551527
Hong Kong	(852) 2506-2422	Switzerland (French)	(41) (1) 0800-551526
Hungary	(36) (1) 252-4647	Taiwan	(886) (2) 719-5589
India	(91) (11) 682-6035	Thailand	(66) (2) 661-3511
Indonesia	(62) (21) 352-2044	United Kingdom	(44) (134) 0800-960271
Italy	(39) (2) 1678-59020	United States	(1) (800) 333-1917
Japan	(81) (3) 3335-8622		

Customer Support Options Worldwide

The service and support chapter of this user's guide contains worldwide sales and service addresses and phone numbers for countries not listed here.

Customer Support and Product Repair Assistance for the U.S. and Canada: (Refer to the service and support chapter of this user's guide for additional product repair information.)	Call (1) (208) 323-2551 Monday through Friday from 6 am to 6 pm (Mountain Time) <i>free of charge during the warranty period. However, your standard long-distance phone charges still apply.</i> Have your system nearby and your serial number ready when calling.		
	If you know your printer needs repair, call (1) (800) 243-9816 to locate your nearest HP-authorized service provider, or call (1) (800) 633-3600 for HP centralized service dispatch.		
	Post-warranty telephone assistance is available to answer your product questions. Call (1) (900) 555-1500 (\$2.50* per minute, U.S. only) or call (1) (800) 999-1148 (\$25* per call, Visa or Master Card, U.S. and Canada) Monday through Friday from 7 am to 6 pm and Saturday from 9 am to 3 pm (Mountain Time). <i>Charges begin only when you connect with a support technician. *Prices subject to change.</i>		
European Customer Support Center Language and In-Country Options Available Open Monday through Friday 8:30–18:00 CET			
HP provides a free telephone support service during the warranty period. By calling a telephone number listed below, you will be connected to a responsive team waiting to help you. If you require support after your warranty has expired, you can receive support for a fee through the same telephone number. The fee is charged on a per-incident basis. When calling HP, have the following information ready: product name and serial number, date of purchase, and description of the problem.			
English Dutch French	Ireland: (353) (1) 662-5525 UK: (44) (171) 512-5202 International: (44) (171) 512-5202 Belgium: (32) (2) 626-8806 Netherlands: (31) (20) 606-8751 France: (33) (45) 043-9853 Belgium: (32) (2) 626-8807 Switzerland: (41) (84) 880-1111	German Norwegian Danish Finnish Swedish Italian Spanish Portuguese	Germany: (49) (180) 525-8143 Austria: (43) (1) 0660-6386 Norway: (47) 2211-6299 Denmark: (45) 3929-4099 Finland: (358) (9) 0203-47288 Sweden: (46) (8) 619-2170 Italy: (39) (2) 264-10350 Spain: (34) 902 321 123 Portugal: (351) (1) 441-7199
In-country support numbers:			
If you require support after your warranty has expired or additional product repair services, or if your country is not listed below, see "Worldwide Sales and Service Offices" in the service and support chapter of this user's guide.			
Argentina	(54) (1) 781-4059 (54) (1) 781-4069	Japan Malaysia	(81) (3) (3335-8333 (60) (3) 295-2566
Australia	(61) (3) 272-8000	México	011-525-265-3330
Brazil	(55) (11) 709-1444	Middle East/Africa	(41) (22) 780-7111
Canada	(1) (208) 323-2551	New Zealand	(64) (9) 356-6640
China	(86) (10) 6261-4174 (86) (10) 6261-4175 (86) (10) 6261-4176 (86) (10) 6262-5666	Philippines Poland Portugal Russia	(63) (2) 894-1451 (48) (22) 608-77-00 (351) (1) 301-7330 (7) (95) 923-5001
Czech Republic	(42) (2) 471-7321	Singapore	(65) 272-5300
Greece	(30) (1) 689-6411	Switzerland	(41) (1) 753-7111
Hong Kong	(852) 800-7729	Taiwan	(886) (2) 717-0055
Hungary	(36) (1) 343-0310	Thailand	(66) (2) 661-4011 66) (2) 661-4012
India	(91) (11) 682-6035 (91) (11) 682-6069	Turkey	((90) (1) 224-5925
Indonesia	(62) (21) 350-3408		
Korea	(82) (2) 3270-0700; outside Seoul, call (82) (80) 999-0700		

Contents

1 Printer Basics

Overview	1
Printer Features and Benefits	2
Printer Information	4
Configurations	4
Printer Parts and Locations	6
Accessories and Supplies	7
Suggested Accessories	7
Ordering Information	8
Control Panel Layout	11
Control Panel Lights	11
Control Panel Keys	12
Control Panel Menus	13
Printer Software	14
Printer Drivers	15
Software for Windows	17
Software for Macintosh Computers	21
Software for Networks	22

2 Printing Tasks

Overview	25
Selecting the Output Bin	26
Printing to the Top Output Bin	27
Printing to the Rear Output Bin	28
Loading Tray 1	30
Loading Tray 2/Optional 250-Sheet Tray	31
Loading the 500-Sheet Tray (Optional)	33
Printing Both Sides of Paper (Optional Duplexer)	35
Printing Special Paper	40
Printing Letterhead, Prepunched, or Preprinted Paper	40
Printing Envelopes	42
Printing Labels	44
Printing Transparencies	46
Printing Rotated Paper	47
Printing Full-Bleed Images	49
Printing Cards, Custom-Size and Heavy Paper	50
Printing Vellum	55

Advanced Printing Tasks	56
Using Features in the Printer Driver	56
Customizing Tray 1 Operation	58
Printing by Type and Size of Paper	60
3 Printer Maintenance	
Overview	63
Managing the Toner Cartridge	64
HP Policy on Non-HP Toner Cartridges	64
Toner Cartridge Storage	64
Toner Cartridge Life Expectancy	64
Continue Printing When Toner is Low	65
Cleaning the Printer	67
4 Problem Solving	
Overview	71
Clearing Paper Jams	72
Clearing Jams from the Input Tray Areas	73
Clearing Jams from the Top Cover Area	74
Clearing Jams from the Output Areas	75
Clearing Jams from the Optional Duplexer	76
Solving Repeated Paper Jams	78
Understanding Printer Messages	79
Correcting Output Quality Problems	89
Determining Printer Problems	91
Troubleshooting Flowchart	91
Troubleshooting Flowchart for Macintosh Users	97
Checking the Printer's Configuration	100
Menu Map	100
Configuration Page	101
PCL or PS Font List	103
5 Service and Support	
Hewlett-Packard Warranty Statement	105
Service During and After the Warranty Period	106
Limited Warranty for Toner Cartridge Life	107
Service Information Form	108
HP Software License Terms	109
Worldwide Sales and Service Offices	110

A Specifications

Overview	A-1
Paper Specifications	A-2
Supported Sizes and Weights of Paper	A-3
Supported Types of Paper	A-6
Labels	A-9
Transparencies	A-9
Vellum	A-10
Envelopes	A-10
Card Stock and Heavy Paper	A-12
Printer Specifications	A-14
Physical Dimensions	A-14
Environmental Specifications	A-17
Serial Cable Specifications	A-19

B Control Panel Menus

Overview	B-1
Information Menu	B-2
Paper Handling Menu	B-3
Print Quality Menu	B-5
Printing Menu	B-7
Configuration Menu	B-10
I/O Menu	B-15
EIO Menu (5000 N/5000 GN)	B-18
Resets Menu	B-20

C Printer Memory and Expansion

Overview	C-1
Installing Memory	C-2
Checking Memory Installation	C-5
Adjusting Memory Settings	C-6
Installing EIO Cards/Mass Storage	C-8

D Printer Commands

Overview	D-1
Understanding PCL Printer Command Syntax	D-2
Combining Escape Sequences	D-3
Entering Escape Characters	D-3
Selecting PCL Fonts	D-4
Common PCL Printer Commands	D-5

E Regulatory Information

FCC Regulations	E-1
Environmental Product Stewardship	E-2
Protecting the Environment	E-2
Toner Material Safety Data Sheet	E-6
Declaration of Conformity	E-7
Safety Statements	E-8
Laser Safety Statement	E-8
Canadian DOC Regulations	E-8
VCCI Statement (Japan)	E-8
Laser Statement for Finland	E-9

Glossary

Index

Printer Basics

Overview

Congratulations on your purchase of an HP LaserJet 5000 series printer. If you have not done so, see the getting started guide provided with the printer for setup instructions.

Now that the printer is set up and ready to use, take a few moments to get to know the printer. This chapter introduces the following:

- Features and benefits of the printer.
- Important printer parts and locations.
- Accessories and supplies available for the printer.
- The layout and basic operation of the printer's control panel.
- Helpful printer software for increased printing flexibility.

Printer Features and Benefits

Many of the printer's features and benefits are outlined below. Specific chapters contain more information on each feature. See this guide's index or contents to locate this information.

Wide Format Printing

Increased capability from your laser printer:

- Prints on paper sizes up to 12.28 by 18.5 inches.
- Prints full bleed images (up to A3 and 11 x 17) by printing images on larger paper that can be trimmed to the edges.

High Print Quality

Professional results that meet the demands of complex documents:

- ProRes 1200 (true 1200 dpi) for highest quality graphics printing.
- FastRes 1200 for fast, high-quality image printing.
- New HP UltraPrecise toner for high quality print.

High Performance

Faster printing for improved productivity:

- Prints 16 pages per minute.
- 100 MHz RISC microprocessor.
- Prints the first page in 12.2 seconds.

Connectivity/Ease of Use

Easy to use and administer in a shared environment:

- Available HP JetDirect print server EIO cards with support for all leading network operating systems.
- Helpful printer software provided on a compact disc.

Expandability

Ability to grow with the printing needs of workgroups:

- 3 built in DIMM slots for memory expansion.
- Available flash and memory DIMM cards.
- Up to 100 MB maximum memory capability.
- 2 EIO interface slots for I/O cards and disk cards.
- Available hard drive EIO card for storage of additional fonts and forms (standard on the HP LaserJet 5000 GN printer).

Paper Handling Options

Versatile to meet a combination of user needs:

- 100 sheet multi-purpose tray.
- 250 sheet paper feeder (standard on all models).
- 500 sheet universal paper feeder (standard on the HP LaserJet 5000 N and 5000 GN models).
- Up to 4 paper trays possible.
- Optional duplex printing accessory for two-sided printing.

Best Value

Providing industry-leading value to customers:

- PostScript™ Level 2 Emulation standard.
- 10,000 page toner cartridge.

Printer Information

This printer can be purchased in three configurations, as described below.

Configurations



HP LaserJet 5000 printer

The HP LaserJet 5000 printer is a 16 ppm laser printer that comes standard with a 100-sheet multi-purpose Tray 1, a 250-sheet Tray 2, and 4 MB of memory. It is designed for workgroups and can print on paper sizes up to A3 and 11 x 17.



HP LaserJet 5000 N printer

The HP LaserJet 5000 N printer is a 16 ppm laser printer that comes standard with a 100-sheet multi-purpose Tray 1, a 250-sheet Tray 2, a 500-sheet Tray 3, 8 MB of memory, and an HP JetDirect print server card for connecting to a network. It is designed for network users and can print on paper sizes up to A3 and 11 x 17.

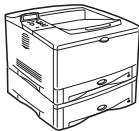

HP LaserJet 5000 GN printer

The HP LaserJet 5000 GN printer is a 16 ppm laser printer that comes standard with a 100-sheet multi-purpose Tray 1, a 250-sheet Tray 2, a 500-sheet Tray 3, 12 MB of memory, an HP JetDirect print server card for connecting to a network, and a hard disk drive. The printer is designed for network users and can print on paper sizes up to A3 and 11 x 17.

A variety of configurations are possible with the optional trays:

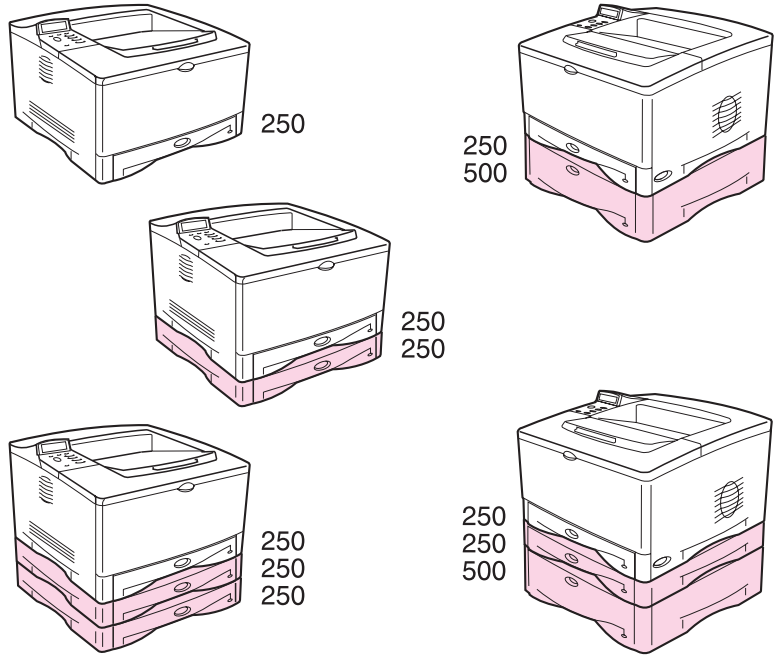

Figure 1 Optional Tray Configurations

Note

A duplexer can be added to any of these configurations and is placed under Tray 2.

Printer Parts and Locations

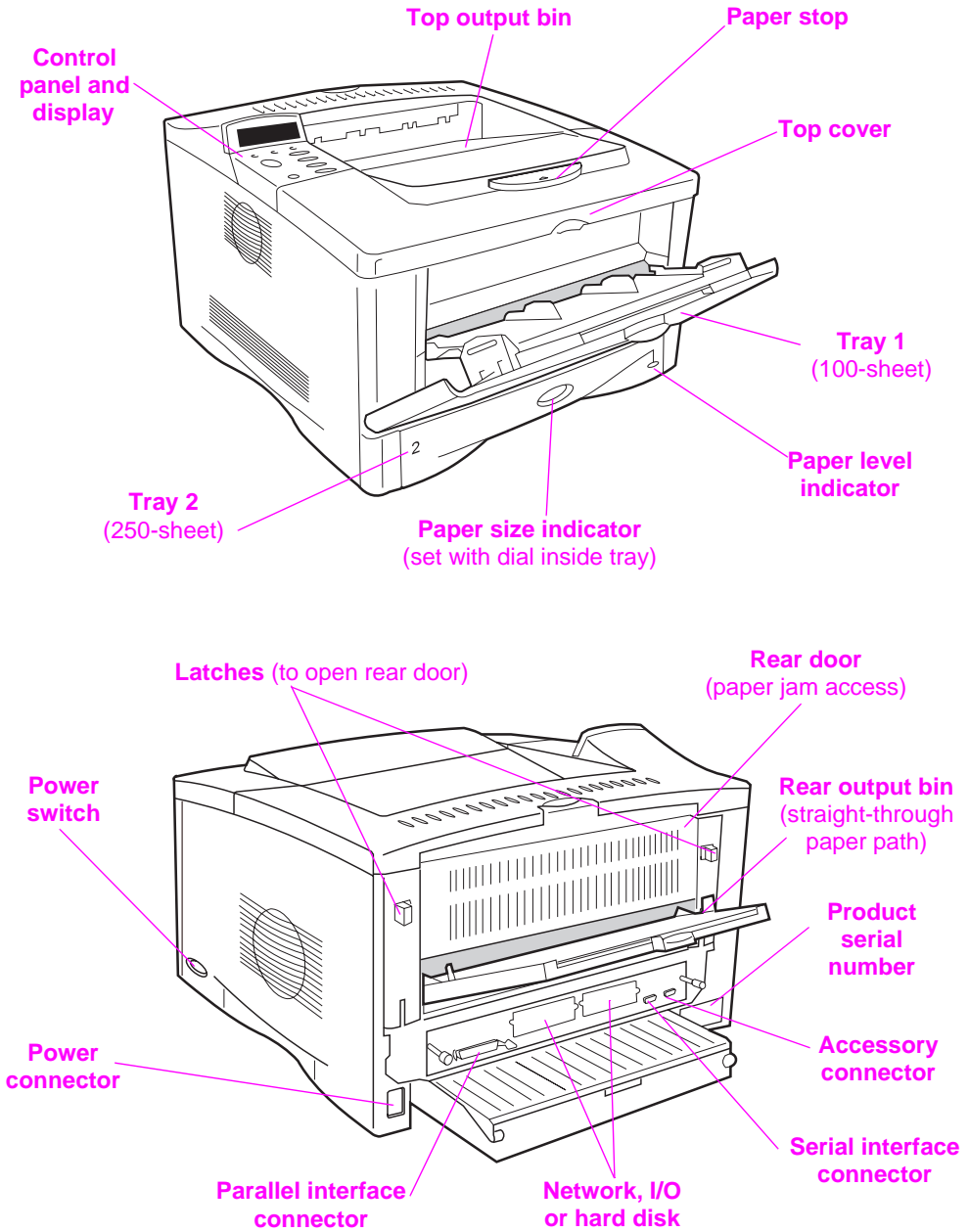

Figure 2 Printer Parts (front and rear views)

Accessories and Supplies

You can increase the capabilities of the printer with optional accessories and supplies.

Note

Use accessories and supplies specifically designed for the printer to ensure optimum performance.

The printer supports two enhanced input/output (EIO) cards. Other accessories and options are available. For ordering information, see the following page.

Suggested Accessories

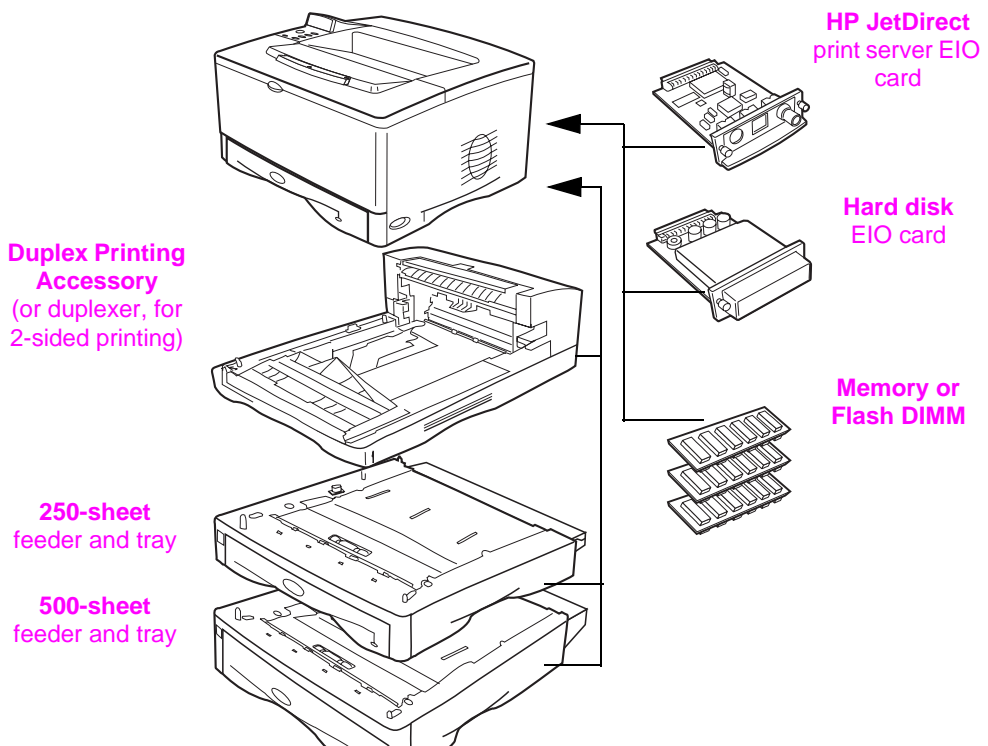

Figure 3 Optional Accessories

Ordering Information

Use only accessories specifically designed for this printer. To order an accessory, contact an HP-authorized service or support provider. (See the HP Support pages at the front of this user's guide.)

Ordering Information

	Item	Description or Use	Part Number
Paper Handling	500-Sheet Paper Feeder and Tray	Paper feeder and one 500-sheet tray.	C4115A
	250-Sheet Paper Feeder and Tray	Paper feeder and one 250-sheet tray.	C4114A
	Duplex Printing Accessory (duplexer)	Allows automatic printing on both sides of paper.	C4113A
	250-Sheet Replacement Tray	Replacement or additional paper tray.	C4116A
	500-Sheet Replacement Tray	Replacement or additional paper tray.	C4117A
Printing Supplies	HP Multi-purpose Paper	HP brand paper for a variety of uses (1 box of 10 reams, 500 sheets each). To order a sample, in the U.S. call 1-800-471-4701.	HPM1120
	HP LaserJet Paper	Premium HP brand paper for use with HP LaserJet printers (1 box of 10 reams, 500 sheets each). To order a sample, in the U.S. call 1-800-471-4701.	HPJ1124
	Toner Cartridge (10,000 pages)	Replacement HP UltraPrecise toner cartridge.	C4129J

Ordering Information (Continued)

	Item	Description or Use	Part Number
Memory, Fonts, and Mass Storage	Dual In-line Memory Module (DIMM)	Boosts the ability of the printer to handle large print jobs (maximum 100 MB with HP brand DIMMs):	
	EDO DIMMs	4 MB	C4135A
		8 MB	C4136A
		16 MB	C4137A
	SDRAM DIMMs	4 MB	C4140A
		8 MB	C4141A
		16 MB	C4142A
		32 MB	C4143A
	Flash DIMM	Permanent storage for fonts and forms:	
		2 MB	C4286A
Font DIMM	4 MB	C4287A	
	8 MB Asian MROM: traditional Chinese simplified Chinese	C4292A C4293A	
Hard Disk	Permanent storage for fonts and forms. Also used to enable HP Transmit Once technology.	C2985A	
Cable and Interface Accessories	Parallel Cables	2 Meter IEEE-1284 cable	C2950A
		3 Meter IEEE-1284 cable	C2951A
	Serial Cables	9-9 pin serial cable (male/female)	C2932A
		9-25 pin serial cable (male/female)	C2933A
	Serial Adapter	25-9 pin adapter (male/female)	C2809A
	Macintosh Computer Serial Cable	For connecting to a Macintosh computer.	92215S
	Macintosh Network Cable Kit	For PhoneNET or LocalTalk connection.	92215N
	Enhanced I/O Cards	HP JetDirect 600N print server multi-protocol EIO network cards:	
		Ethernet RJ-45 only	J3110A
		Ethernet RJ-45 and BNC, LocalTalk	J3111A
Token Ring RJ-45 and DB-9 Fast Ethernet RJ-45 only		J3112A J3113A	

Ordering Information (Continued)

Item	Description or Use	Part Number
<i>HP LaserJet Printer Family Paper Specification Guide</i>	A guide to using paper and other print media with HP LaserJet printers.	5010-6394
<i>PCL 5/PJL Technical Reference Documentation Package</i>	A guide to using printer commands with HP LaserJet printers.	5021-0330
<i>HP LaserJet 5000, 5000 N, and 5000 GN Printers User's Guide</i>	An additional copy of this user's guide.	C4110-90901 (English)
<i>HP LaserJet 5000, 5000 N, and 5000 GN Printers Getting Started Guide</i>	An additional copy of the getting started guide.	C4110-90926 (English)
<i>HP LaserJet 5000, 5000 N, and 5000 GN Printers Quick Reference Guide</i>	An additional copy of the quick reference guide.	C4110-90976 (English)
User's Documentation Bundle,	An additional copy of this user's guide, the getting started guide, and the quick reference guide.	C4110-99001 (English)

Documentation

Control Panel Layout

The printer's control panel consists of the following:

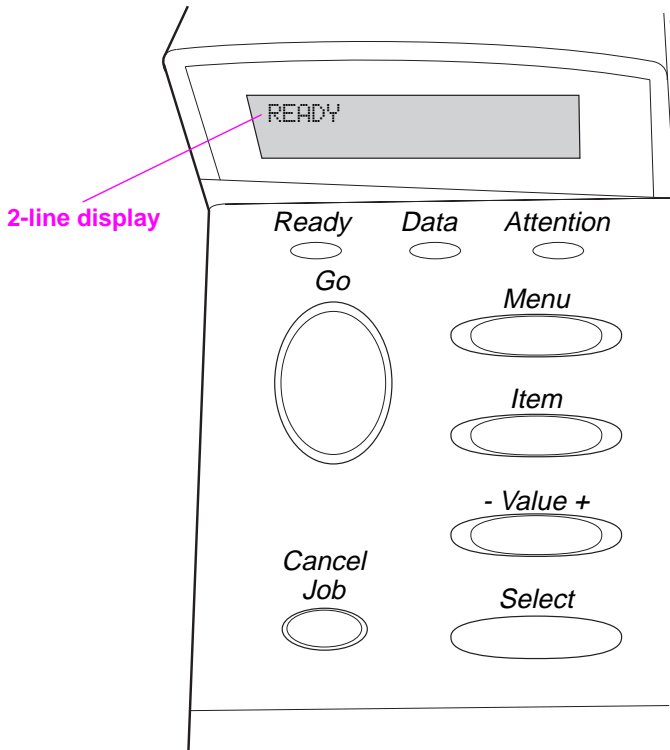

Figure 4 Control Panel Layout

Control Panel Lights

Light	Indication
Ready	The printer is ready to print.
Data	The printer is processing information.
Attention	Action is required. See the control panel display.

Control Panel Keys

Key	Function
[Go]	<ul style="list-style-type: none">• Places the printer either online or offline.• Prints any data residing in the printer's buffer.• Allows the printer to resume printing after being offline. Clears most printer messages and places the printer online.• Allows the printer to continue printing with an error message such as TRAY x LOAD [TYPE] [SIZE] or UNEXPECTED PAPER SIZE.• Confirms a manual feed request if Tray 1 is loaded and TRAY 1 MODE=CASSETTE has been set from the Paper Handling Menu in the printer's control panel.• Overrides a manual feed request from Tray 1 by selecting paper from the next available tray.• Exits the control panel menus. (To save a selected control panel setting, first press [Select].)
[Cancel Job]	Cancels the print job that the printer is processing. The time it takes to cancel depends on the size of the print job. (Press it only once.)
[Menu]	Cycles through the control panel menus. Press the right end of the button to move forward or the left end of the button to move backward.
[Item]	Cycles through the selected menu's items. Press the right end of the button to move forward or the left end of the button to move backward.
[- Value +]	Cycles through the selected menu item's values. Press [+] to move forward or [-] to move backward.
[Select]	<ul style="list-style-type: none">• Saves the selected value for that item. An asterisk (*) appears next to the selection, indicating that it is the new default. Default settings remain when the printer is switched off or reset (unless you reset all factory defaults from the Resets Menu).• Prints one of the printer information pages from the control panel.

Control Panel Menus

For a complete list of control panel items and possible values, see page B-1.

Press **[Menu]** for access to all control panel menus. When additional trays or other accessories are installed in the printer, new menu items automatically appear.

To change a control panel setting:

- 1 Press **[Menu]** until the desired menu appears.
- 2 Press **[Item]** until the desired item appears.
- 3 Press **[- Value +]** until the desired setting appears.
- 4 Press **[Select]** to save the selection. An asterisk (*) appears next to the selection in the display, indicating that it is now the default.
- 5 Press **[Go]** to exit the menu.

Note

Settings in the printer driver and software application override control panel settings. (Software application settings override printer driver settings.)

If you cannot access a menu or item, it is either not an option for the printer, or your network administrator has locked the function. (The control panel reads ACCESS DENIED MENU LOCKED.) See your network administrator.

To print a control panel menu map:

To see the current settings for all of the menus and items available in the control panel, print a control panel menu map.

- 1 Press **[Menu]** until INFORMATION MENU appears.
- 2 Press **[Item]** until PRINT MENU MAP appears.
- 3 Press **[Select]** to print the menu map.

You might want to store the menu map near the printer for reference. The content of the menu map varies, depending on the options currently installed in the printer.

Printer Software

The printer comes with helpful software on a compact disc. See the getting started guide for installation instructions.

Note

Check the ReadMe file provided on the compact disc for additional software included and supported languages.

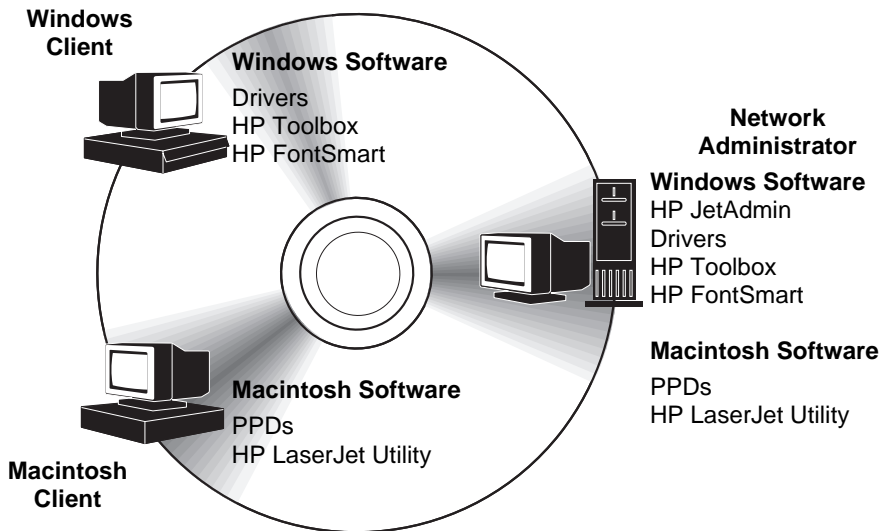

Figure 5 Printer Software

The printer drivers provided on the compact disc must be installed to take full advantage of the printer's features. The other software programs are recommended, but are not required for operation. See the ReadMe file for more information.

Note

Network Administrators: HP JetAdmin should be installed only on the network administrator's computer. Load all other applicable software on the server and all client computers.

The most recent drivers, additional drivers, and other software are available from the Internet. Depending on the configuration of Windows-driven computers, the installation program for the printer software automatically checks the computer for Internet access to obtain the latest software. If you do not have access to the Internet, see the HP Support pages at the front of this user's guide to obtain the most recent software.

Printer Drivers

Printer drivers access the printer features and allow the computer to communicate with the printer (via a printer language).

Note

Check the ReadMe file provided on the compact disc for additional software included and supported languages.

Certain printer features are available only from the PCL 6 driver. See the printer software help for availability of features.

Drivers Included with the Printer

The following printer drivers are included with the printer. The most recent drivers are available on the Internet. Depending on the configuration of Windows computers, the installation program for the printer software automatically checks the computer for Internet access to obtain the latest drivers.

	PCL 5e	PCL 6	PS ¹
Windows 3.1x	✓	✓	✓
Windows 95	✓	✓	✓
Windows NT 3.51 ²			✓
Windows NT 4.0	✓	✓	✓
Macintosh computer	PPDs are included (page 21).		

1. PostScript Level 1 Emulation for Windows 3.1x; Level 2 Emulation for all other operating systems.
2. The PCL 5e driver is available from the Internet. (See the HP support pages at the front of this user's guide.)

Within the computer installation program, select **Typical Install** to install the PCL 5e, PCL 6, and PS drivers and HP FontSmart. Select **Custom Install** to install only the software you prefer, or if you are a network administrator. Select **Minimum Install** to install only the PCL 6 driver for basic printing.

Additional Drivers

You can obtain the following printer drivers by downloading them from the Internet, or by requesting them from an HP-authorized service or support provider. (See the HP Support pages at the front of this user's guide.)

- OS/2 PCL/PCL 6 printer driver*
- OS/2 PS printer driver*
- WordPerfect 5.1 printer driver
- Windows NT 3.51 PCL 5e printer driver
- AutoCAD (Rev. 14 compatible printer driver, also available on the compact disc)

*The OS/2 drivers are also available from IBM, and are packaged with OS/2.

Note

If the desired printer driver is not on the compact disc or is not listed here, check the software application's installation disks or ReadMe files to see if they include support for the printer. If not, contact the software manufacturer or distributor and request a driver for the printer.

Software for Windows

Use the **Typical Install** or **Custom Install** option to install the HP software. (This includes several printer drivers. For more information, see page 15.)

Note

Network Administrators: If the printer is attached to a network, before you can print, the printer must be configured for that network using HP JetAdmin or similar network software. (See the getting started guide.)

Access the Windows Printer Driver

To configure the driver, access it in one of the following ways:

Operating System	Temporarily Change Settings (from a software application)	Change Default Settings (across all applications)
Windows 95 and Windows NT 4.0	From the File menu, click Print , and then click Properties . (The actual steps can vary; this is the most common method.)	Click the Start button, point to Settings , and then click Printers . Right-click the printer icon, and choose Properties .
Windows 3.1x and Windows NT 3.51	From the File menu, click Print , click Printers , and then click Options . (The actual steps can vary; this is the most common method.)	From the Windows control panel, double-click Printers , highlight the printer, and click Setup .

Note

Settings in the printer driver and software application override control panel settings. (Software application settings override printer driver settings.)

Choose the Right Printer Driver for Your Needs

Choose a printer driver based on the way you use the printer.

- Use the PCL 6 driver to take full advantage of the printer's features. Unless backward compatibility with previous PCL drivers or older printers is necessary, the PCL 6 driver is recommended.
- Use the PCL 5e driver if you want print results to look comparable to those from older printers. Certain features are not available in this driver. (Do not use the PCL 5e driver provided with this printer with older printers.)
- Use the PS driver for compatibility with PostScript Level 2 needs. Certain features are not available in this driver.

The printer automatically switches between PS and PCL printer languages.

Printer Driver Help

Each printer driver has help screens that can be activated either from the Help button, the F1 key, or a question mark symbol in the upper right corner in the printer driver (depending on the Windows operating system used). These help screens give detailed information about the specific driver. Printer driver help is separate from the software application help.

HP ToolBox

Access HP ToolBox from a printer icon on the desktop in Windows 3.1x or on the Windows 95 and Windows NT 4.0 **Taskbar**. HP ToolBox provides one-step access to the current status of the printer and a list of all available features, including the following:

- printer status
- “How Do I...” help
- utilities

From HP ToolBox you can launch utilities such as HP JobMonitor. If you choose not to use HP ToolBox, it can be disabled. See the printer software help.

HP JobMonitor

HP JobMonitor is a component of HP ToolBox that shows the position of print jobs in the queue, which print jobs have been printed, and who sent them. To access JobMonitor, right-click the tray icon in HP ToolBox, and then select **Jobs** from the **Contents** menu.

HP FontSmart

Access HP FontSmart from the HP LaserJet folder or through HP ToolBox. HP FontSmart is a font management utility (for Windows only) which does the following:

- installs, uninstalls, and deletes fonts
- manages fonts inside a single window by allowing you to drag-and-drop
- shows the 110 matching screen fonts for the internal fonts in the printer
- downloads fonts to a mass storage device

Note

With Windows 3.1x and Windows 95, you can use HP FontSmart to download fonts to a mass storage device. Types of fonts supported are TrueType, PostScript Type 1 and PostScript Type 42 (TrueType fonts converted to PostScript format). To download Type 1 fonts, Adobe Type Manager must be installed and turned on.

HP JetSend Communications Technology



HP JetSend can be installed through an installer on the compact disc. HP JetSend is a new technology from Hewlett-Packard that allows network devices to communicate with each other directly. Devices which contain the HP JetSend technology can exchange information directly with other devices connected via the Internet or intranet. Sending devices can include scanners and computers. Receiving devices can include printers and computers. In addition to sending and receiving documents, you can view documents using the HP JetView software.

HP JetSend technology enables flexible, direct communications between network devices using simple IP addressing. HP JetSend enables simple, targeted, information exchange that is independent of both servers and applications. This means that users can easily exchange information directly between Internet-connected devices like printers and scanners (and other devices in the future).

HP JetSend capabilities can be integrated into the Microsoft Windows environment. For example, using devices enabled with HP JetSend, you can capture a document with a scanner (or create a document using computer software) for distribution via the Internet to several users. Users can receive the document in their computer's InBox or print directly to their HP LaserJet 5000 series printer.

Software for Macintosh Computers

PostScript Printer Description Files (PPDs)

PPDs, in combination with the LaserWriter driver, access the printer features and allow the computer to communicate with the printer. An installation program for the PPDs and other software is provided on the compact disc. Use the LaserWriter printer driver that comes with the computer. (The LaserWriter driver is also available from Apple.)

HP LaserJet Utility

HP LaserJet Utility allows control of features that are not available in the driver. The illustrated screens make selecting printer features from the Macintosh computer easier than ever. Use the HP LaserJet Utility to do the following:

- Customize the printer's control panel messages.
- Name the printer, assign it to a zone on the network, download files and fonts, and change most of the printer settings.
- Set a password for the printer.
- From the computer, lock out functions on the printer's control panel to prevent unauthorized access. (See the printer software help.)

Software for Networks

HP JetAdmin

HP JetAdmin should be installed only on the network administrator's computer. HP JetAdmin can be accessed by clicking the **Start** button (point to **Settings**, and then click **Control Panel**) in Windows 95 and Windows NT 4.0 or from the HP LaserJet program group folder. Use HP JetAdmin to do the following:

- Install, configure, and manage printers on a network that are connected with a JetDirect print server.
- Perform in-depth diagnostics on the printer and network.

The HP JetAdmin software works on the following network systems:

- Windows NT
- Windows 95
- Windows 3.1x
- Novell NetWare
- HP-UX*
- Solaris*
- SunOS*
- OS/2*

*The software for these systems is not included on the compact disc with the printer, but is available from the Internet. If you do not have access to the Internet, see the HP Support pages at the front of this user's guide to obtain this software.

Note

Network Administrators: If the printer is attached to a network, before you can print, the printer must be configured for that network using HP JetAdmin or similar network software. (See the getting started guide.)

HP Web JetAdmin

This web-based HP JetAdmin software should be installed on a web server. The following systems are supported:

- Windows NT
- HP-UX*
- OS/2*

*The software for these systems is not included on the compact disc with the printer, but is available from the Internet. If you do not have access to the Internet, see the HP Support pages at the front of this user's guide to obtain this software.

Printing Tasks

Overview

This chapter presents **basic printing tasks**, such as:

- Selecting the output bin.
- Loading the trays.
- Printing on both sides of paper with the optional duplexer.
- Printing on special paper, such as letterhead and envelopes.

This chapter also introduces some **advanced printing tasks**, to help you take full advantage of the printer's features. These tasks are "advanced" because they require you to change settings from a software application, the printer driver, or the printer's control panel.

- The printer driver allows you to:
 - Create Quick Sets to save the printer's setup information for different kinds of print jobs.
 - Print pages with a watermark in the background.
 - Print the first page of a document on a different kind of paper than the rest of the pages.
 - Print multiple pages on one sheet of paper.(See "Using Features in the Printer Driver" on page 56.)
- Tray 1 can be used in several different ways. See "Customizing Tray 1 Operation" on page 58.
- If you frequently use several kinds of paper or share the printer with others, print by type and size to ensure that print jobs always print on the desired paper. See "Printing by Type and Size of Paper" on page 60.

Selecting the Output Bin

The printer has two output locations: the rear output bin and the top output bin. To use the top output bin, be sure the rear output bin is closed. To use the rear output bin, open it.

The following table shows the minimum and maximum sizes of paper supported in the output bins.

	Top Output Bin	Rear Output Bin
Width	From 3.9 to 11.7 inches wide (100 to 297 mm wide)	From 3 to 12.28 inches wide (76 to 312 mm wide)
Length	From 5 to 18.5 inches long (127 to 470 mm long)	

Guidelines

- If paper coming out of the top output bin has problems, such as excessive curl, try printing to the rear output bin.
- To avoid paper jams, do not open or close the rear output bin while the printer is printing.
- Do not print envelopes, labels, paper wider than 11.7 inches (297 mm) wide, small custom-size paper, postcards, or light or heavy paper to the top output bin.
- For printing stacks of large paper only, the paper stop on the top output bin prevents long paper from being pushed over the edge of the printer.

Printing to the Top Output Bin

The top output bin collects paper face-down, in correct order. The top output bin should be used for most print jobs and is recommended for printing the following:

- over 50 sheets of paper, continuously
- transparencies

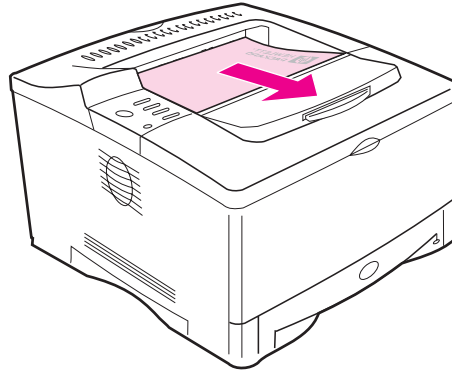

Figure 6 Top Output Bin

Printing to the Rear Output Bin

The printer always prints to the rear output bin if it is open. Paper comes out of the printer face-up, with the last page on top.

To open the rear output bin, grasp the handle at the top of the bin and pull the bin down. Slide out the first extension, then flip open the second extension if necessary.

Printing from Tray 1 to the rear output bin provides the straightest paper path. Opening the rear output bin might improve output quality with the following:

- envelopes
- labels
- paper wider than 11.7 inches (297 mm) or less than 3.9 inches (100 mm) wide
- small custom-size paper
- postcards
- paper lighter than 16 lb (60 g/m²) or heavier than 28 lb (105 g/m²)

Note

Opening the rear output bin disables the optional duplexer (if installed) and the top output bin.

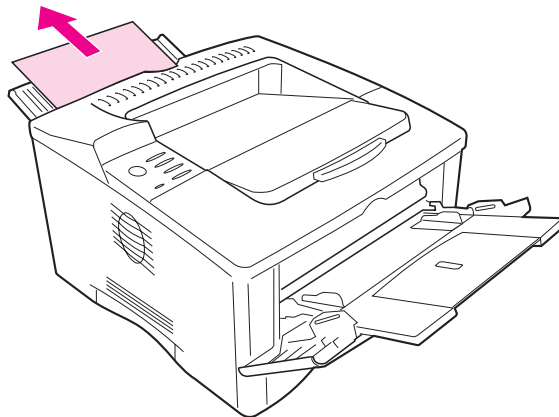
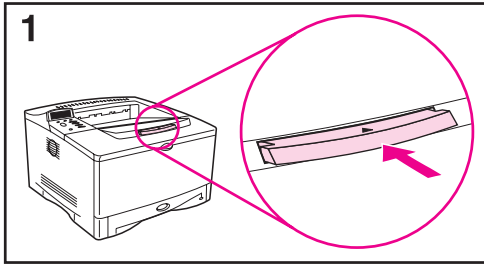

Figure 7 Rear Output Bin

Adjust the Paper Stop



For printing stacks of large paper only, the paper stop on the top output bin prevents long paper from being pushed over the edge of the printer.

1 Push in the center of the paper stop to release it.

2 Pull the paper stop out until it stops.

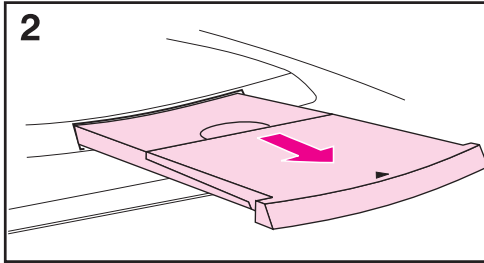

3 Flip up the end section.

4 Adjust the paper stop to the desired size.

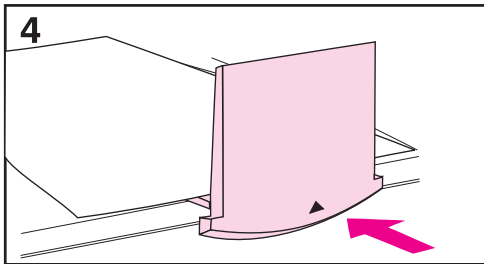
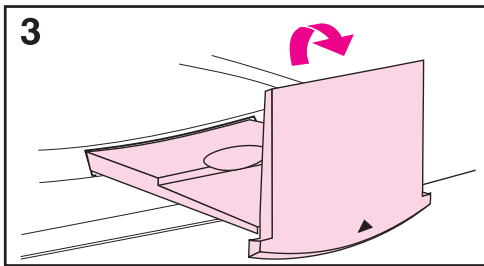

Loading Tray 1

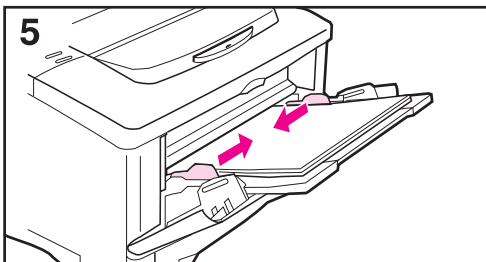
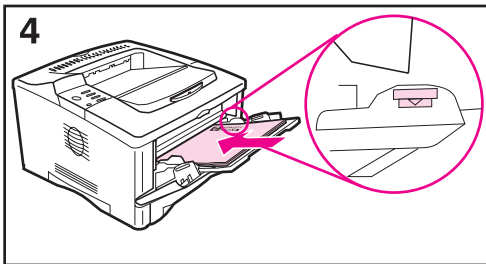
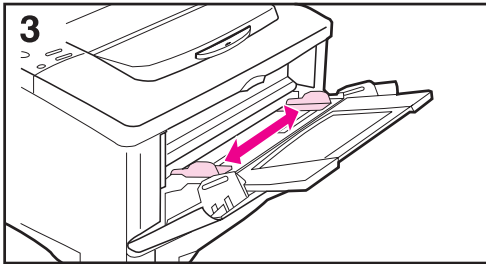
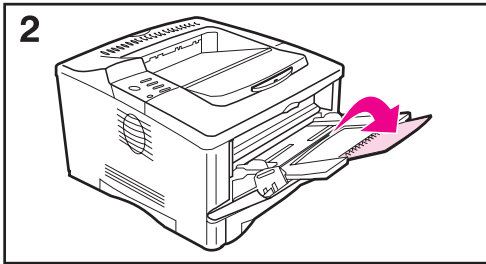
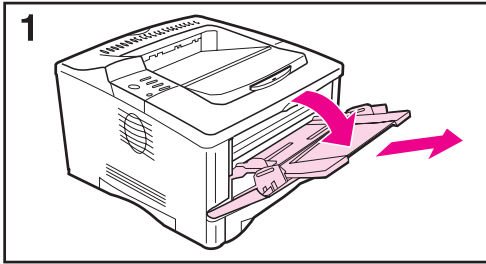

Note

To avoid paper jams, do not load trays while the printer is printing.

Tray 1 is a multi-purpose tray that holds a variety of paper, including up to 100 sheets of paper, 10 envelopes, or 20 index cards. The printer might pull paper from Tray 1 first. To change this, see page 58. For supported sizes of paper, see page A-3.

1 Open Tray 1 and pull out the tray extension.

2 If the paper being loaded is longer than 9 in (229 mm), flip open the second tray extension.

3 Set the side guides to the desired size.

4 Load Tray 1. Paper should fit under the arrows and tabs on the guides. For correct orientation, see page 41.

- For example, load letter, A4, A5, Executive, and B5 size paper with the long edge toward the printer.

- Load other sizes of paper with the short edge toward the printer.

5 Make sure the guides touch the edges of the paper without bending it.

Loading Tray 2/Optional 250-Sheet Tray

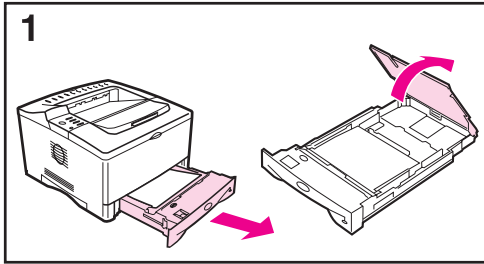

The following instructions are for loading Tray 2 or an optional 250-sheet paper tray. For supported sizes of paper, see page A-4.

Note

To avoid paper jams, do not load trays while the printer is printing.

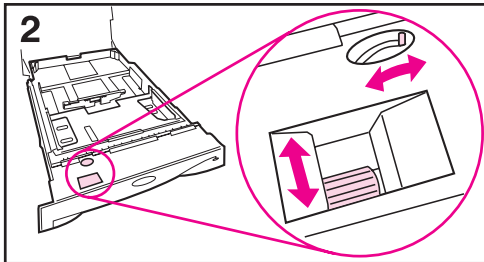

1 Pull the tray completely out of the printer. Lift the tray cover.

2 Rotate the dial in the tray so the printer will read the correct size of paper. The toggle switch accesses more sizes. An error message will appear in the control panel display if the dial is not set properly.

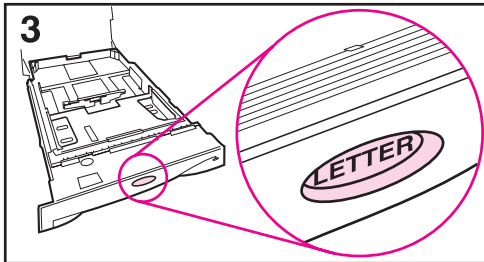

Note

Setting the dial adjusts the printer's sensors. It does not adjust the guides inside the tray.

3 Make sure the paper size setting matches the size of paper loaded, or the printer might jam or other errors might occur.

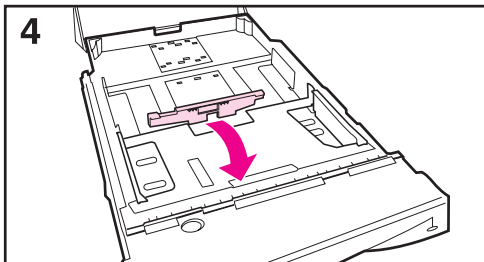

4 Tilt the blue rear guide toward the front of the tray to detach it.

Continued on the next page.

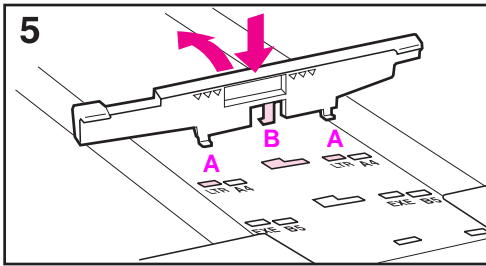

5 Align the rear guide with the desired paper size. With the guide angled slightly toward the front of the tray, insert the two front tabs (A) into the appropriate holes. Push the guide upright, snapping the center tab (B) into place.

The guide must always be placed correctly in the tray (even for 11 x 17 or A3 paper).

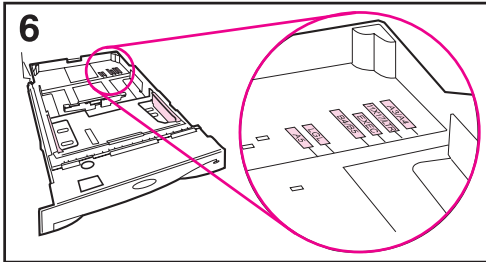

6 Adjust the side guides to the proper size.

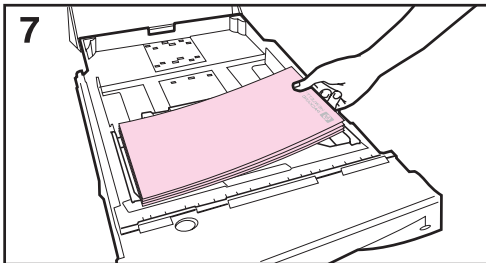

7 Load the tray. For correct orientation, see page 41.

8 Make sure the paper is flat in the tray at all four corners and below the tabs on the guides.

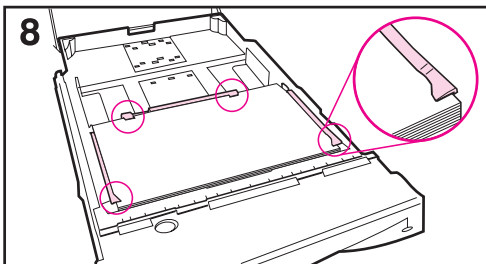

9 Close the tray cover. Slide the tray back into the printer.

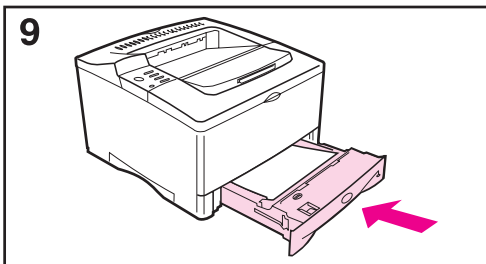

Note

If you want to print by type and size of paper from the printer driver, configure the tray settings in the printer's control panel to match the type of paper loaded in each tray (page 60).

Loading the 500-Sheet Tray (Optional)

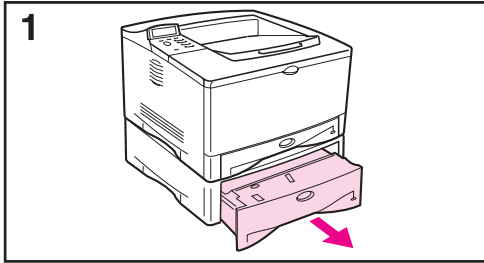

The following instructions are for loading standard sizes in a 500-sheet tray (optional). For supported sizes of paper, see page A-5. To load custom-sizes, see page 50.

Note

To avoid paper jams, do not load trays while the printer is printing.

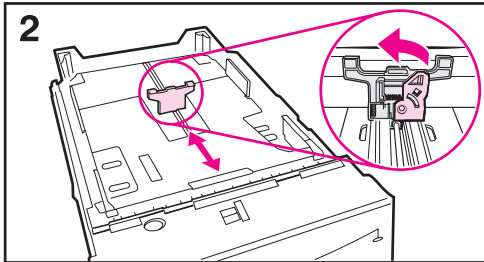

1 Pull the tray completely out of the printer and place it on a flat surface.

2 Squeeze the release on the back of the rear paper guide. Slide the guide to the desired paper size.

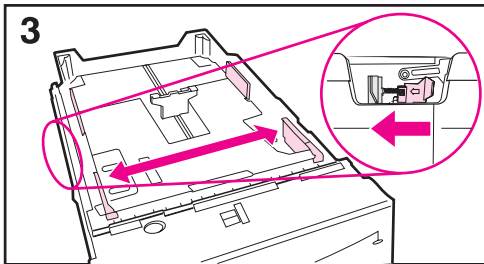

3 Squeeze the release on the outside of the left guide and adjust the left and right guides to match the width of the paper. The guides should touch the paper without bending it.

4 Load the tray. For correct orientation, see page 41.

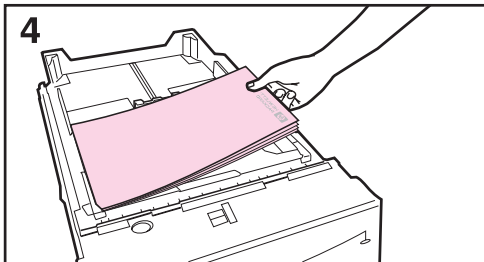

5 Make sure the paper is flat in the tray at all four corners and below the tabs on the guides.

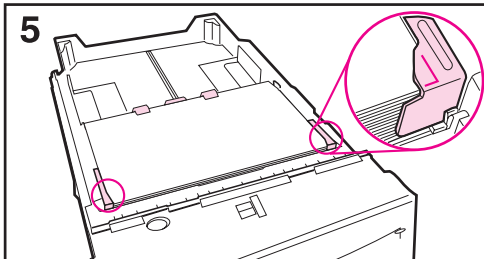

Continued on the next page.

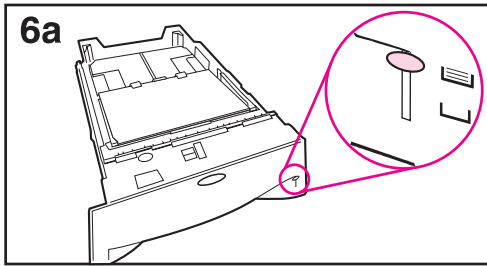

6a When loading a full stack of media, continue to step 6B. Otherwise, proceed to step 7.

6b Align the tension lever up or down to match the symbol displayed in the tension indicator window.

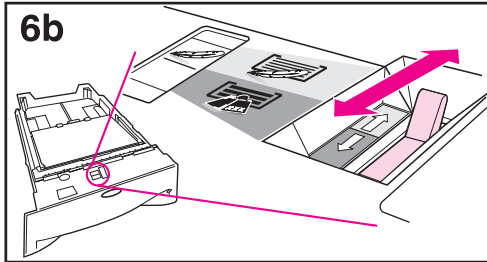

7 To prevent jams, rotate the dial in the tray so the printer will read the correct size of paper. The toggle switch accesses more sizes. An error message will appear in the control panel display if the dial is not set properly.

8 Slide the tray into the printer.

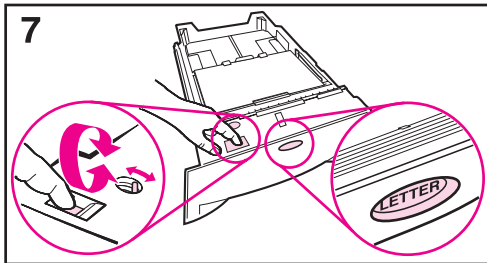

Note

If you want to print by type and size of paper from the printer driver, configure the tray settings in the printer's control panel to match the type of paper loaded in each tray (page 60).

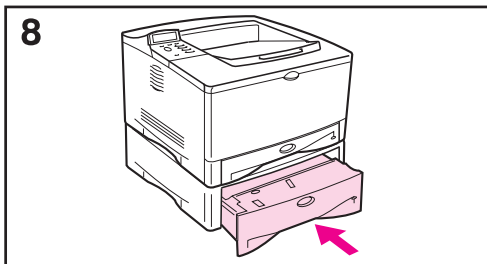

Printing Both Sides of Paper (Optional Duplexer)

The printer can automatically print on both sides of paper with an optional duplex printing accessory (duplexer). This is called duplexing. To order optional accessories, see page 8.

Note

See the documentation included with the duplexer for complete installation and setup instructions. Duplexing might require additional memory (page C-1).

The duplexer supports sizes from 5.8 by 8.3 inches (148 by 210 mm) to 11.7 by 17 inches (297 by 432 mm).

Prepunched paper should be printed in a rotated direction for 2-sided printing (page 47).

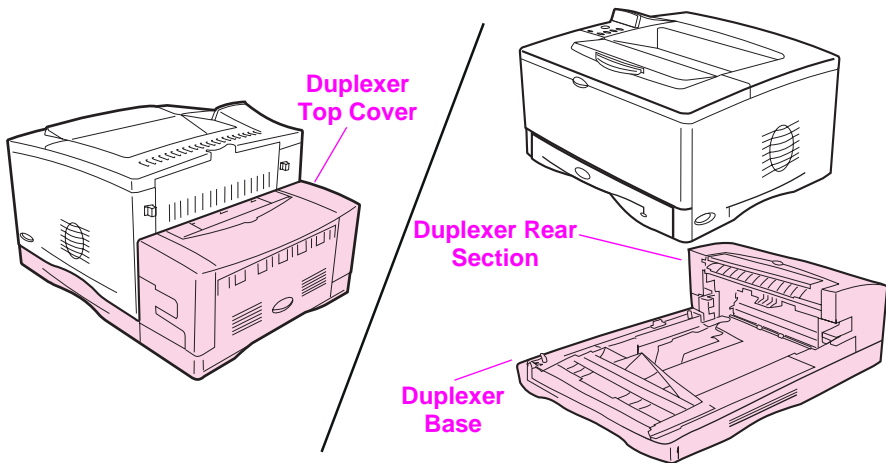

Figure 8 Printer with the Optional Duplexer

Guidelines for Printing Both Sides of Paper

Caution

Do not print on both sides of labels, transparencies, envelopes, vellum, or paper heavier than 28 lb (105 g/m²). Damage to the printer and paper jamming might result.

WARNING!

To avoid personal injury and damage to the printer, do not lift the printer with the duplexer installed. Before relocating the printer, separate the duplexer and optional trays from the printer.

- You might need to configure the printer driver to recognize the duplexer. (See the printer software help for details.)
- To print on both sides of paper, make the selection from the software or printer driver. (See the printer software help.)
- If the printer driver does not have this option, change the Duplex setting from the Paper Handling Menu in the printer's control panel to `DUPLEX=ON`. Also in the Paper Handling Menu, set Binding to long edge or short edge. (For more information, see page 39.)
- Be sure that Tray 2 is in place with its cover down. (The paper passes over this cover when duplexing.)
- Close the rear output bin to use the duplexer (page 26). Opening the rear output bin disables the duplexer.

Separating the Printer from the Duplexer

Before you lift the printer, always separate the printer from the duplexer.

- 1 Slide the rear section of the duplexer away from the printer.
- 2 Lift the printer off the duplexer.

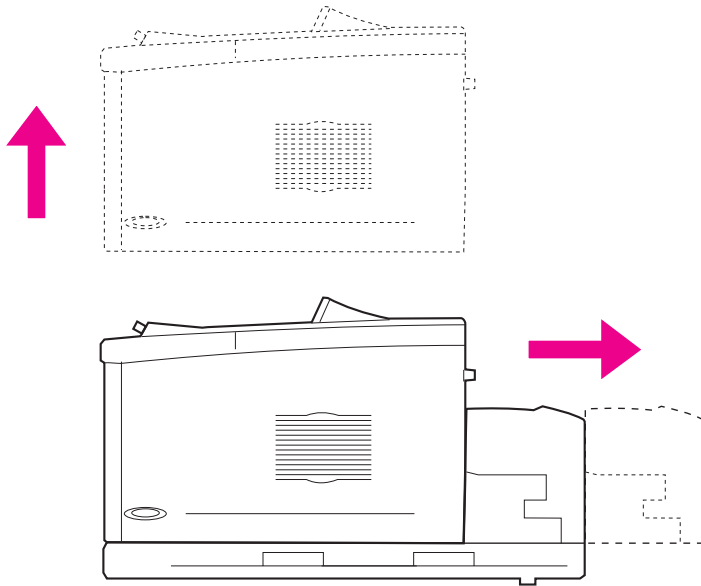

Figure 9 Separating the Printer from the Duplexer

Paper Orientation for Printing Both Sides of Paper

The duplexer prints the second side of paper first, so paper such as letterhead, prepunched, and preprinted paper need to be oriented as shown in Figure 10.

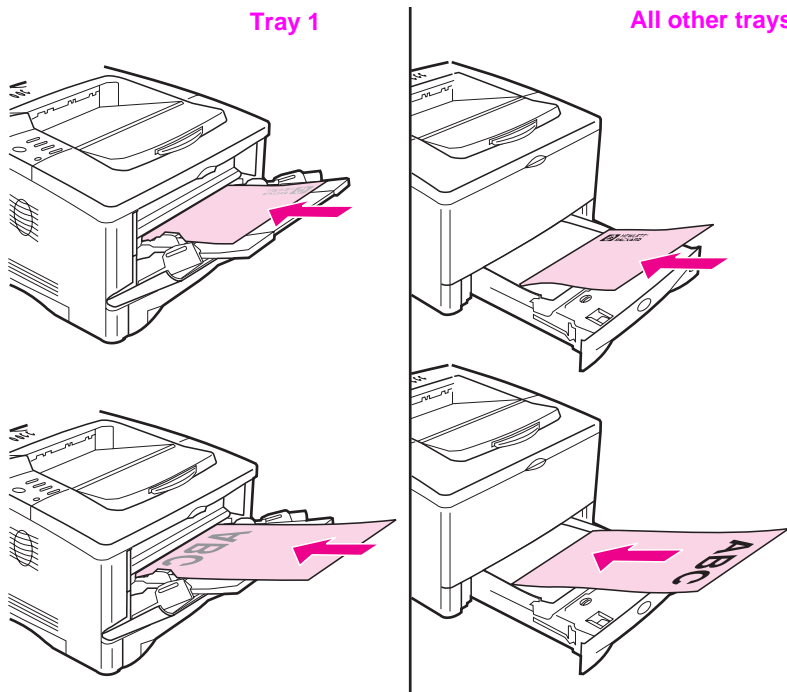

Figure 10 Paper Orientation for Printing Both Sides of Paper

For Tray 1, load the first side facing down.

- Load letter, A4, A5, Executive, and B5 paper with the top, short edge toward the right.
- Load other sizes with the top, short edge toward the printer.

For all other trays, load the first side facing up.

- Load letter, A4, A5, Executive, and B5 paper with the top, short edge toward the right.
- Load other sizes with the top, short edge toward the front of the tray.

Layout Options for Printing Both Sides of Paper

The four print orientation options are shown below. These options can be selected from the printer driver or from the printer's control panel (set **BINDING** from the Paper Handling Menu and **ORIENTATION** from the Printing Menu).

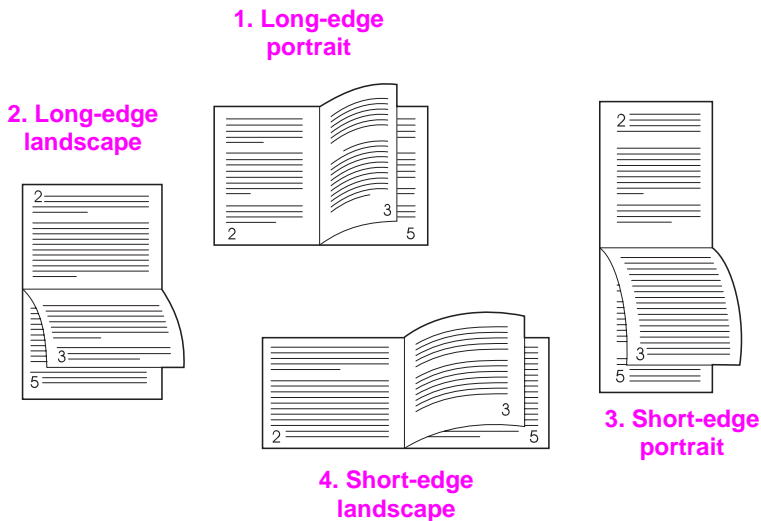

Figure 11 Layout Options for Printing Both Sides of Paper

- | | |
|-------------------------|--|
| 1. Long-edge portrait | This is the default printer setting, and the most common layout used, with every printed image oriented right side up. Facing pages are read from top to bottom on the left page, then from top to bottom on the right page. |
| 2. Long-edge landscape | This layout is often used in accounting, data processing, and spreadsheet applications. Every other printed image is oriented upside-down. Facing pages are read continuously from top to bottom. |
| 3. Short-edge portrait | This layout is often used with clipboards. Every other printed image is oriented upside-down. Facing pages are read continuously from top to bottom. |
| 4. Short-edge landscape | Each printed image is oriented right side up. Facing pages are read from top to bottom on the left page, then from top to bottom on the right page. |

Printing Special Paper

Special paper includes letterhead, prepunched (including 3-hole punched), envelopes, labels, transparencies, full-bleed images, rotated paper, index cards, postcards, custom-size, and heavy paper.

Printing Letterhead, Prepunched, or Preprinted Paper

When printing letterhead, prepunched, or preprinted paper, it is important to load the trays with the correct orientation.

Note

Paper orientation is different when you print with an optional duplexer (page 38).

It may be necessary to print prepunched paper in a rotated orientation (page 47).

Printing in portrait or landscape mode is usually selected from the software application or printer driver. If the option is not available, change the Orientation setting from the Printing Menu in the printer's control panel (page B-8).

Paper Orientation

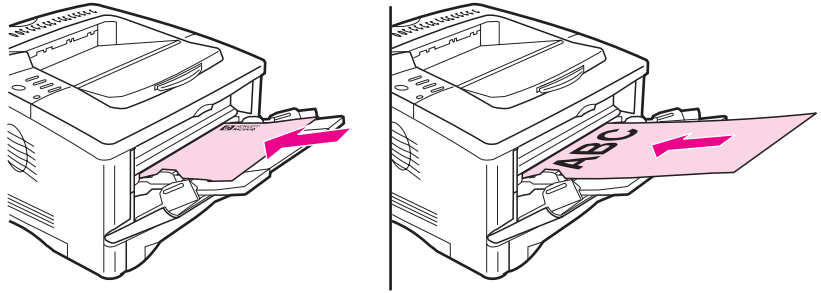

Figure 12 Paper Orientation for Tray 1

- Load letter, A4, A5, Executive, and B5 paper with the side-to-be-printed facing up, and the top, short edge toward the right.
- Load other sizes of paper with the side-to-be-printed facing up, and the top, short edge toward the printer.

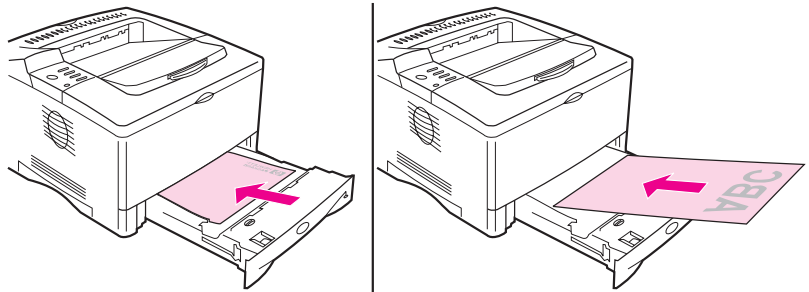

Figure 13 Paper Orientation for All Other Trays

- Load letter, A4, A5, Executive, and B5 paper with the side-to-be-printed facing down, and the top, short edge toward the right.
- Load other sizes with the side-to-be-printed facing down, and the top, short edge toward the front of the tray.

Printing Envelopes

Many types of envelopes can be printed from Tray 1. (Up to 10 can be stacked in the tray.) Printing performance depends on the construction of the envelope. Always test a few sample envelopes before purchasing a large quantity.

- Set margins at least 0.6 inch (15 mm) from the edge of the envelope.
- To minimize curl and wrinkling, always print envelopes to the rear output bin.

When you print large numbers of envelopes and standard paper, for best printing performance print paper first, then envelopes. To alternate paper and envelopes, from the Configuration Menu in the printer's control panel select `SMALL PAPER SPEED=SLOW`.

WARNING!

Never use envelopes with coated linings, exposed self-stick adhesives, or other synthetic materials. These items can emit noxious fumes.

Caution

Envelopes with clasps, snaps, windows, coated linings, exposed self-stick adhesives, or other synthetic materials can severely damage the printer.

To avoid jamming and possible printer damage, never try to print on both sides of an envelope.

Before you load envelopes, make sure they are flat and not damaged or stuck together. Do not use envelopes with pressure-sensitive adhesive. (For envelope specifications, see page A-10.)

Loading Envelopes in Tray 1

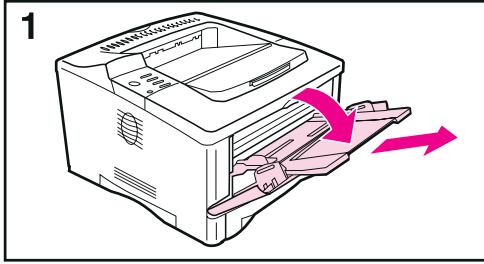

1 Open Tray 1 and pull out the tray extension. If the envelopes are longer than 9 inches (229 mm), flip open the second tray extension.

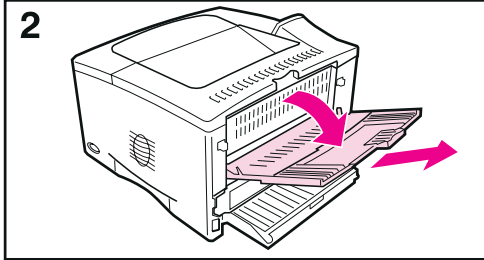

2 Open the rear output bin and pull out the tray extension. (This reduces envelope curl and wrinkling.)

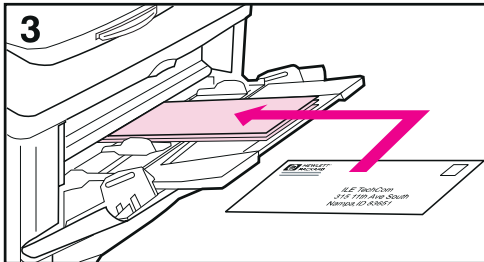

3 Load up to 10 envelopes in the center of Tray 1 with the side-to-be-printed facing up, and the postage-end toward the front of the tray. Slide the envelopes into the printer as far as they will go without forcing them.

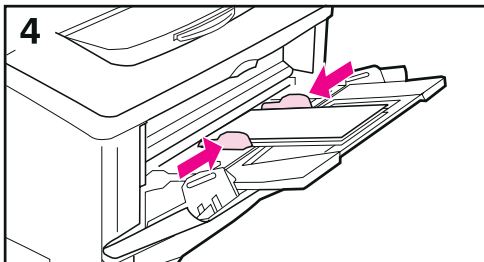

4 Adjust the guides to touch the envelope stack without bending the envelopes. Make sure the envelopes fit under the tabs on the guides.

Printing Labels

Use only labels recommended for use in laser printers. Multi-thickness labels and labels that do not stack flat might print better rotated. To print rotated paper, see page 47. Make sure that labels meet the specifications for the input tray you use (page A-9).

Do:

- Print a stack of 50 labels from Tray 1 or a stack of 50 to 100 labels from other trays.
- Load labels with the side-to-be-printed facing up, and the top, short edge toward the right, if they are letter or A4 size. For other sizes, see page 41.
- Try opening the rear output bin (page 28) to prevent curl and other problems.

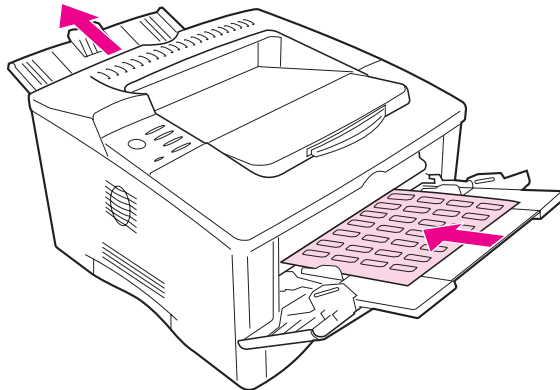

Figure 14 Printing Labels

Do not:

Caution

Failure to follow these instructions can damage the printer.

- Do not load the trays to capacity because labels are heavier than paper.
- Do not use labels that are separating from the backing sheet, wrinkled, or damaged in any way.
- Do not use labels that have the backing sheet exposed. (Labels must cover the entire backing sheet with no exposed spaces.)
- Do not feed a sheet of labels through the printer more than once. The adhesive backing is designed for only one pass through the printer.
- Do not print on both sides of labels.

Printing Transparencies

Use only transparencies recommended for use in laser printers. For transparency specifications, see page A-9.

- Load transparencies in Tray 1 with the side-to-be printed facing up and the top edge toward the right.
- To prevent transparencies from becoming too hot or sticking together, use the top output bin by closing the rear output bin (page 27). Remove each transparency from the output bin before printing another.
- Place transparencies on a flat surface to cool after removing them from the printer.

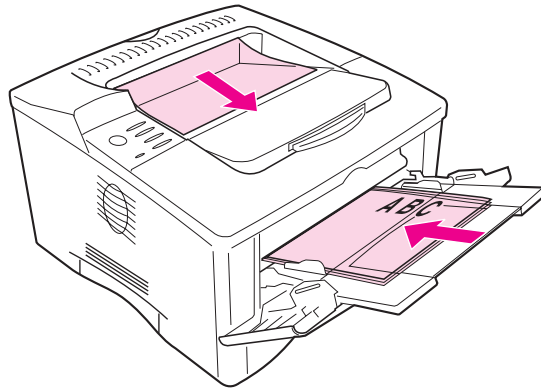

Figure 15 Printing Transparencies

Printing Rotated Paper

The printer can print letter, A4, A5, Executive, and B5 (JIS) in a rotated orientation (short-edge first) from Tray 1. The printer can print letter and A4 in a rotated orientation from a 500-sheet tray. Rotated paper prints slower. Some types of paper feed better rotated, such as prepunched paper (especially printed on both sides with the optional duplexer) or labels that do not stack flat.

Tray 1:

- 1 From the Paper Handling Menu in the printer's control panel, select TRAY 1 MODE=CASSETTE.
- 2 Also from the Paper Handling Menu, select LTR-R, A4-R, A5-R, EXEC-R, or JB5-R as the paper size.
- 3 Load paper with the side-to-be printed facing up, and the top, short-edge toward the printer.
- 4 In the printer driver or software application select the non-rotated version of the size and select the tray containing the rotated paper.

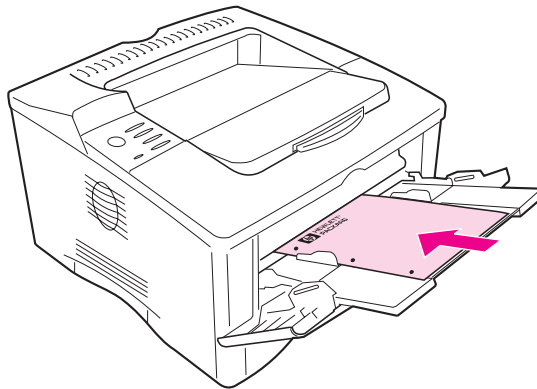

Figure 16 Printing Rotated Paper from Tray 1

500-Sheet Tray:

- 1 Rotate the dial inside the front of the tray to the correct paper size.
- 2 From the Paper Handling Menu in the printer's control panel, select LTR-R or A4-R as the paper size.
- 3 Load paper with the side-to-be printed facing down, and the top, short-edge toward the front of the tray.
- 4 In the printer driver or software application select the size and location of the rotated paper.

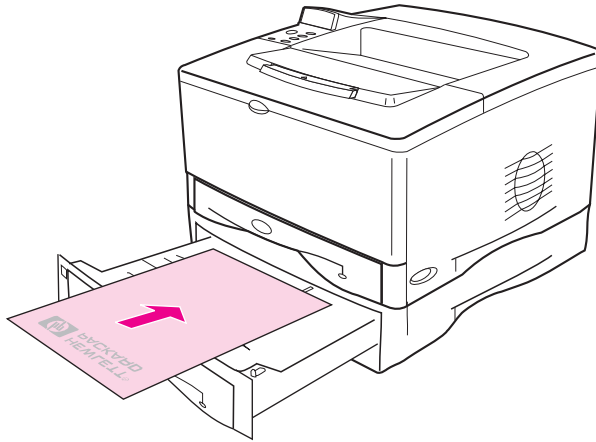

Figure 17 Printing Rotated Paper from the 500-Sheet Tray

Printing Full-Bleed Images

Full-bleed images extend from edge to edge of the page. To achieve this effect, use larger paper, then trim its edges to the desired size.

Caution

Never print directly to the edge of paper. This causes toner to accumulate inside the printer, which may affect print quality and damage the printer. Print on paper up to 12.28 by 18.5 in (312 by 470 mm), leaving margins on all four sides of at least .08 inch (2 mm).

Note

When printing paper wider than 11.7 inches (297 mm), always use the rear output bin. Do not use the optional duplexer when printing this size of paper.

Printing Cards, Custom-Size and Heavy Paper

Custom-size paper can be printed from Tray 1 or the optional 500-sheet tray. For paper specifications, see page A-2.

Tray	Minimum Size	Maximum Size
Tray 1	3 by 5 inches (76 by 127 mm)	12.28 by 18.5 inches (312 by 470 mm)
Optional 500-Sheet Tray	5.8 by 8.2 inches (148 by 210 mm)	11.7 by 16.5 inches (297 by 419 mm) OR 11 x 17 inches (280 by 432 mm)

The maximum paper weight is 53 lb (199 g/m²) from Tray 1 and 28 lb (105 g/m²) from the 500-sheet tray.

Note

Heavy paper and very small or very large custom-size paper should be printed from Tray 1 to the rear output bin. Open the rear output bin to use it (page 28).

The printer's control panel can be set for one custom size at a time. Do not load more than one size of custom paper into the printer.

For information on setting custom paper sizes, see page 53.

Loading Custom-Size Paper in the 500-Sheet Tray

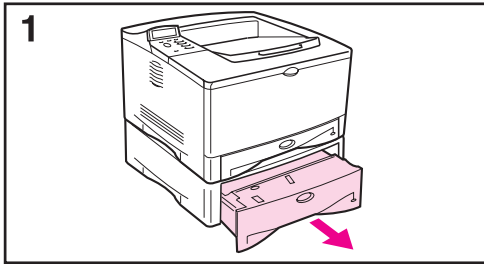

The following instructions are for loading custom-sizes in a 500-sheet tray (optional). For supported sizes of paper, see page A-5. To load standard sizes, see page 33.

Note

To avoid paper jams, do not load trays while the printer is printing.

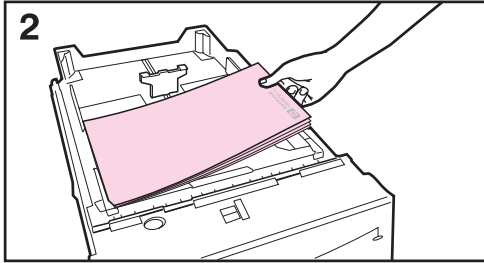

1 Pull the tray completely out of the printer and place it on a flat surface.

2 Load the tray.

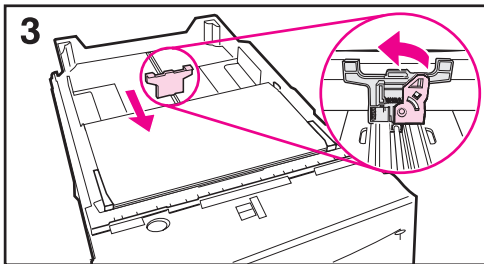

3 Squeeze the release on the back of the rear paper guide. Slide the rear guide against the edge of the paper. The front corners of the paper should be lined up with the marks on the front side guide's tabs.

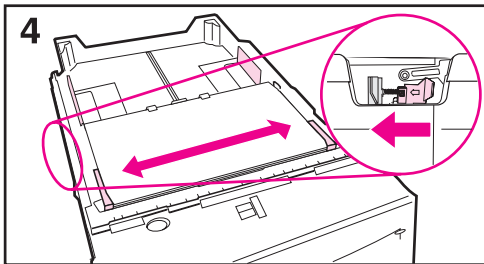

4 Squeeze the release on the outside of the left guide and adjust the left and right guides to match the width of the paper. The front corners of the paper should be below the tabs on the guides, and the edges should be lined up with the markings on the tabs. The guides should touch the paper without bending it.

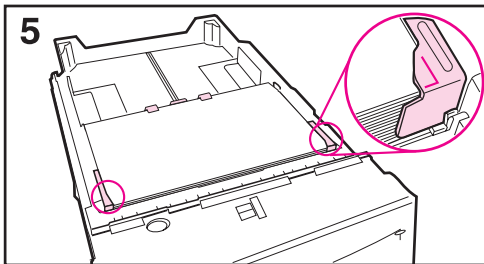

5 Make sure the paper is flat in the tray at all four corners and below the tabs on the guides.

Continued on the next page.

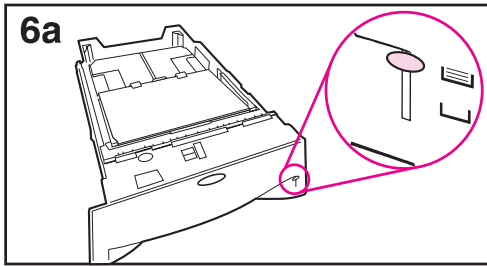

6a When loading a full stack of media, continue to step 6B. Otherwise, proceed to step 7.

6b Align the tension lever up or down to match the symbol displayed in the tension indicator window.

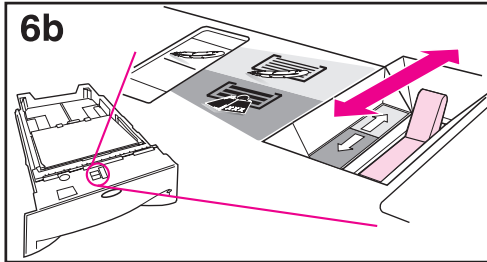

7 To prevent jams, rotate the dial in the tray so the printer will read the correct size of paper. The toggle switch accesses more sizes. An error message will appear in the control panel display if the dial is not set properly.

8 Slide the tray into the printer.

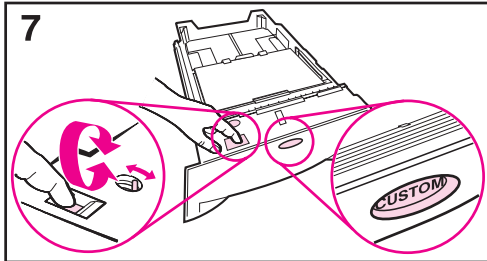

Note

If you want to print by type and size of paper from the printer driver, configure the tray settings in the printer's control panel to match the type of paper loaded in each tray (page 60).

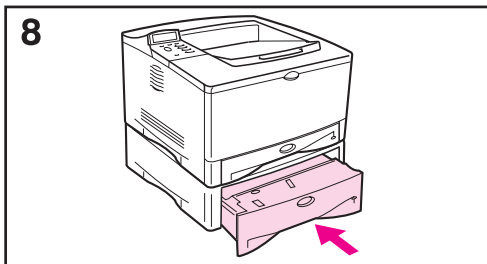

Guidelines for Printing Custom-Size Paper

- Do not attempt to print on paper smaller than 3 inches (76 mm) wide or 5 inches (127 mm) long.
- Set page margins at least .17 inch (4.23 mm) away from the edges.

Setting Custom Paper Sizes

When custom paper is loaded, size settings need to be selected from the software application (the preferred method), the printer driver, and from the printer's control panel.

Note

All settings in the printer driver and software application (except configuring custom paper sizes) override control panel settings. (Software application settings override printer driver settings.) The control panel must be set if the PCL 5e driver is used, or custom paper is loaded long-edge first (X is longer than Y).

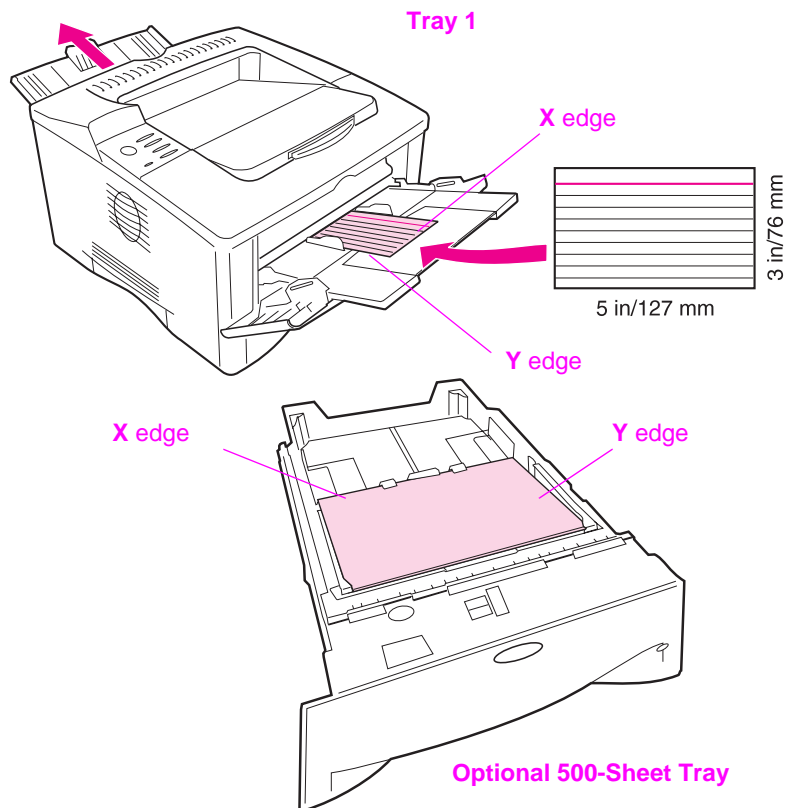

Figure 18 Printing Custom-Size Paper

If the settings are not available from the software, set the custom paper size from the control panel:

- 1 From the Printing Menu set `CONFIGURE CUSTOM PAPER=YES`.
- 2 From the Printing Menu, select inches or millimeters as the unit of measurement.
- 3 From the Printing Menu, set the X dimension (the front edge of the paper) as shown in Figure 18. X can be 3 to 12.28 inches (76 to 312 mm) for Tray 1 or 5.8 to 11.7 inches (148 to 297 mm) for the 500-sheet tray (optional). Set the Y dimension (the side edge of the paper) as shown in Figure 18. Y can be 5 to 18.5 inches (127 to 470 mm) for Tray 1 or 8.2 to 17 inches (210 to 432 mm) for the 500-sheet tray (optional).
- 4 If custom paper is loaded into Tray 1 and `TRAY 1 MODE=CASSETTE`, then set `TRAY 1 SIZE=CUSTOM` from the Paper Handling Menu in the printer's control panel. See "Customizing Tray 1 Operation" on page 58.

If custom paper is loaded in the optional 500-sheet tray, be sure the paper size dial is set to Custom.

- 5 In the software, select **Custom** as the paper size.

For example, if the custom paper is 8 by 10 inches (203 by 254 mm), set X=8 inches and Y=10 inches (X=203 millimeters and Y=254 millimeters).

Printing Vellum

Vellum is special lightweight paper similar to parchment. Print vellum from Tray 1 only, and open the rear output bin. Do not print on both sides of vellum.

- 1 Load vellum with the side-to-be-printed facing up and the top, short edge toward the right.
- 2 Open the rear output bin.
- 3 From the Paper Handling Menu in the printer's control panel, set TRAY 1 MODE=CASSETTE.
- 4 From the printer driver, set the type of paper for Tray 1 to vellum, and select paper by type. For details on selecting by type of paper, see page 60.

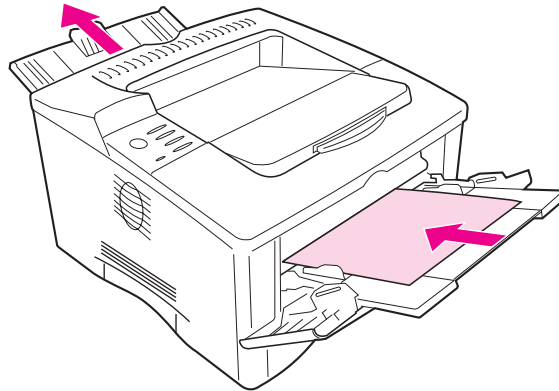

Figure 19 Printing Vellum

Advanced Printing Tasks

This section will help you take full advantage of the printer's features. These tasks are "advanced" because they require you to change settings from the printer's control panel or the printer driver.

Using Features in the Printer Driver

When you print from a software application, many of the printer's features are available from the printer driver. To access Windows printer drivers, see page 17.

Note

HP PCL 5e, PCL 6, PS, and Macintosh drivers are slightly different. Check the drivers for available options. The PCL 6 driver takes full advantage of the printer's features.

Settings in the printer driver and software application override control panel settings. (Software application settings override printer driver settings.)

Saving Printer Setup Information

Printer drivers allow you to save the printer settings you use most often as the default settings. For example, the driver might be set to print on letter size paper, portrait orientation, with automatic tray selection (from the first available tray).

Some PCL 6 printer drivers will allow you to save printer settings for multiple kinds of print jobs. For example, you might want to create a Quick Set for envelopes, or for printing the first page of a document on letterhead.

Look for the **Quick Sets** option in the Windows PCL 6 printer driver, or see the printer driver help for more information.

Printing with a Watermark

A watermark is a notice, such as "Top Secret," printed in the background of each page in a document. Check the driver for available options.

Printing the First Page on Different Paper

From the PCL 6 printer driver, you can choose to print the first page of a document on different paper than the rest of the pages. Look for “Use different paper for first page” in the printer driver.

Printing Multiple Pages on One Sheet of Paper

You can print more than one page on a single sheet of paper. This feature is available in some printer drivers, and provides a cost-effective way to print draft pages.

To print more than one page on a sheet of paper, look for a Layout or Pages Per Sheet option in the printer driver. (This is sometimes called 2-up, 4-up, or n-up printing.)

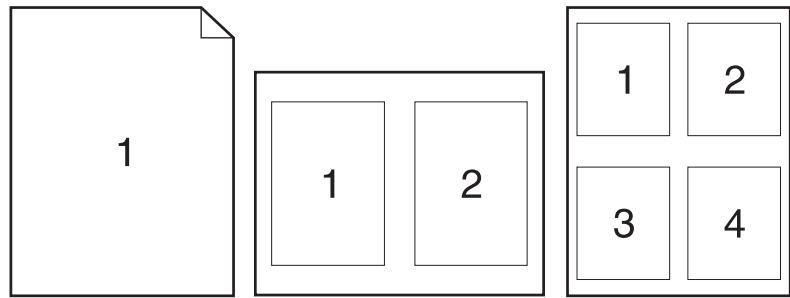

Figure 20 Sample Layout Options (1-up, 2-up, and 4-up)

Customizing Tray 1 Operation

Customize Tray 1 to fit your printing needs.

The printer can be set to print from Tray 1 as long as it is loaded, or to print only from Tray 1 if the type of paper loaded is specifically requested. Set `TRAY 1 MODE=FIRST` or `TRAY 1 MODE=CASSETTE` from the Paper Handling Menu in the printer's control panel. (Print speed might be slightly slower when printing from Tray 1 when `TRAY 1 MODE=FIRST`.)

Tray 1 Mode=First

If you do not keep paper in Tray 1 all the time, or you use Tray 1 only for manually feeding paper, keep the default setting, `TRAY 1 MODE=FIRST` in the Paper Handling Menu.

- `TRAY 1 MODE=FIRST` means that the printer usually pulls paper from Tray 1 first unless it is empty or closed.
- You can still choose paper from other trays by specifically choosing another tray in the printer driver.

Tray 1 Mode=Cassette

`TRAY 1 MODE=CASSETTE` means the printer treats Tray 1 like the internal trays. Instead of looking for paper in Tray 1 first, the printer pulls paper either starting from the bottom tray upward (from the tray with the highest capacity to the tray with the least capacity), or the tray that matches type or size settings selected from the software.

- When `TRAY 1 MODE=CASSETTE` is set, an option appears in the Paper Handling Menu to configure **size** as well as **type** settings for Tray 1.
- Through the printer driver, you can select paper from any tray (including Tray 1) by type, size, or source. To print by type and size of paper, see page 60.

Manually Feeding Paper from Tray 1

The Manual Feed feature allows you to print on special paper from Tray 1, such as envelopes or letterhead. If Manual Feed is selected, the printer will print only from Tray 1.

Select Manual Feed through the software or printer driver. Manual Feed can also be enabled from the Paper Handling Menu in the printer's control panel.

Note

When Manual Feed is selected, if `TRAY 1 MODE=FIRST` the printer automatically prints (if paper is in the tray). If `TRAY 1 MODE=CASSETTE` the printer prompts to load Tray 1 whether or not Tray 1 is loaded. This enables you to load different paper if necessary. Press **[Go]** to print from Tray 1.

Printing by Type and Size of Paper

You can configure the printer to select paper by **type** (such as plain or letterhead) and **size** (such as letter or A4), as opposed to **source** (a paper tray).

Benefits of Printing by Type and Size of Paper

If you frequently use several different kinds of paper, once trays are set up correctly, you do not have to check which paper is loaded in each tray before you print. This is especially helpful when the printer is shared, and more than one person loads or removes paper.

Printing by type and size of paper is a way to be sure that print jobs always print on the desired paper. (Some printers have a feature which “locks out” trays, to prevent printing on the wrong paper. Printing by type and size of paper eliminates the need to lock out trays.)

To print by type and size of paper, do the following:

- 1 Be sure to adjust and load the trays correctly. (See the sections on loading paper, starting on page 30.)
- 2 From the Paper Handling Menu in the printer’s control panel, select the paper **type** for each tray. If you are unsure what type you are loading (such as bond or recycled), check the label on the package of paper. For supported types, see page A-13.
- 3 Select the paper **size** settings from the control panel.
 - **Tray 1:** If the printer has been set to `TRAY 1 MODE=CASSETTE` from the Paper Handling Menu, also set the paper size from the Paper Handling Menu. If custom paper is loaded, set the size of custom paper from the Printing Menu to match the paper loaded in Tray 1. To print custom-size paper, see page 53.
 - **Optional 500-sheet tray:** Paper size settings are adjusted when paper is properly loaded into the printer and the paper size dial is set to match the paper size. If custom paper is loaded, set the size of custom paper from the Printing Menu to match the paper loaded in the tray. Set the paper size dial in the tray to Custom. To print custom-size paper, see page 53.
 - **Other trays:** Paper size settings are adjusted when paper is properly loaded into the printer and the paper size dials are set to match the paper size (See the sections on loading paper, starting on page 31.)
- 4 From the software or printer driver, select the desired type and size of paper.

Note

The type and size settings can also be configured from HP JetAdmin for networked printers. See the printer software help.

To print by type and size, it might be necessary to unload or close Tray 1, or set `TRAY 1 MODE=CASSETTE` from the Paper Handling Menu in the printer's control panel. For more information, see page 58.

Settings in the printer driver and software application override control panel settings. (Software application settings override printer driver settings.)

Printer Maintenance

Overview

This chapter explains basic printer maintenance.

- Managing the toner cartridge.
- Cleaning the printer.

Note

To ensure optimum print quality, the printer will prompt you to have routine maintenance performed every 150,000 pages. When the `PERFORM PRINTER MAINTENANCE` message appears on the control panel, contact an HP-authorized service and support provider to have the maintenance performed. (See the HP Support pages at the front of this user's guide.)

Managing the Toner Cartridge

HP Policy on Non-HP Toner Cartridges

Hewlett-Packard Company cannot recommend use of non-HP toner cartridges, either new or remanufactured. Because they are not HP products, HP cannot influence their design or control their quality.

To install a new HP toner cartridge and recycle the used cartridge, follow the instructions included in the toner cartridge box.

Toner Cartridge Storage

Do not remove the toner cartridge from its package until you are ready to use it. (The shelf life of a cartridge in an unopened package is approximately 2.5 years.)

Caution

To prevent damage to the toner cartridge, do not expose it to light for more than a few minutes.

Toner Cartridge Life Expectancy

The life of the toner cartridge depends on the amount of toner that print jobs require. When printing text at 5% coverage, an HP toner cartridge lasts an average of 10,000 pages. (A typical business letter is about 5% coverage.) This assumes that print density is set to 3 and EconoMode is off. (These are the default settings.)

Continue Printing When Toner is Low

When toner is low, the printer's control panel displays the `TONER LOW` message.

- If the `TONER LOW` message displays, but the printer continues printing, `TONER LOW` is set to `CONTINUE` (the default setting).
- If the printer stops printing when low toner is detected, `TONER LOW` is set to `STOP`. To resume printing, press **[Go]**.

The printer will continue to display `TONER LOW` until you replace the toner cartridge.

Select `TONER LOW=CONTINUE` or `TONER LOW=STOP` from the Configuration Menu in the control panel (page B-12).

Redistributing the Toner

When toner is low, faded or light areas might appear on a printed page. You might be able to temporarily improve print quality by redistributing the toner. The following procedure might allow you to finish the current print job before replacing the toner cartridge.

Redistributing the Toner (continued)

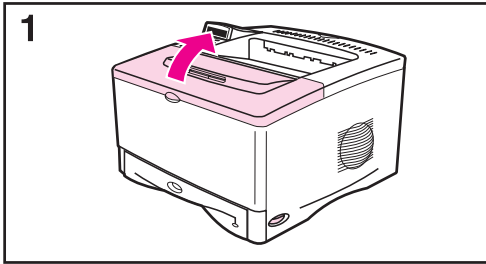

1 Open the top cover.

2 Remove the toner cartridge from the printer.

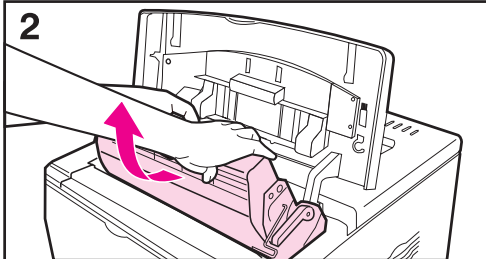

WARNING!

Avoid reaching too far into the printer. The adjacent fusing area might be hot!

Caution

To prevent damage to the toner cartridge, do not expose it to light for more than a few minutes.

3 Rotate the toner cartridge and gently shake it from side to side to redistribute the toner.

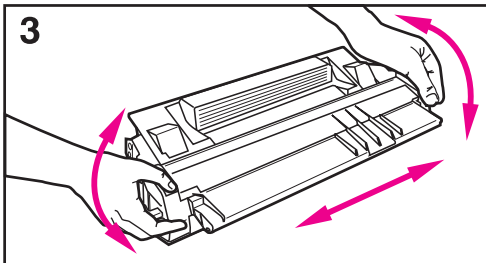

Note

If toner gets on your clothing, wipe it off with a dry cloth and wash clothing in cold water. (Hot water sets toner into fabric.)

4 Reinsert the toner cartridge into the printer and close the top cover.

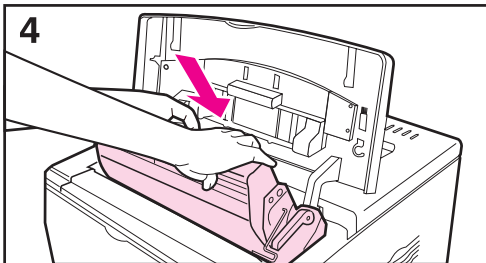

If the print remains light, install a new toner cartridge. (Follow the instructions provided with the new toner cartridge.)

Cleaning the Printer

To maintain print quality, follow the cleaning procedure (on the following page) every time the toner cartridge is changed, or whenever print quality problems occur. As much as possible, keep the printer free from dust and debris.

- Clean the outside of the printer with a slightly water-dampened cloth.
- Clean the inside with a dry, lint-free cloth.

Caution

Do not use ammonia-based cleaners on or around the printer.

While cleaning the printer, be careful not to touch the transfer roller (the black, rubber roller, located underneath the toner cartridge). Skin oils on the roller can cause print quality problems.

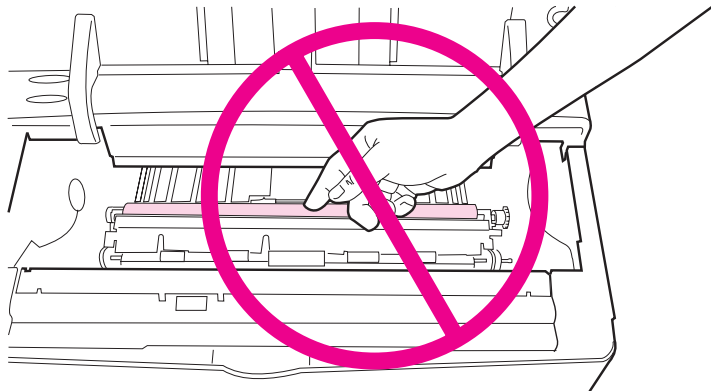
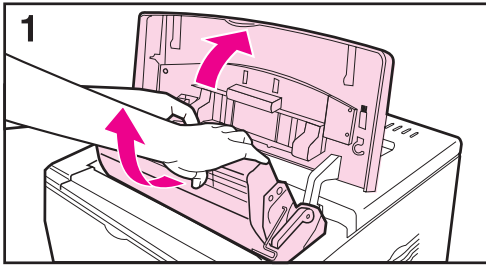

Figure 21 Location of the Transfer Roller—Do Not Touch!

Cleaning the Printer



Before beginning these steps, turn the printer off and unplug the power cord.

- 1 Open the top cover and remove the toner cartridge.

WARNING!

Avoid reaching too far into the printer. The adjacent fusing area might be hot!

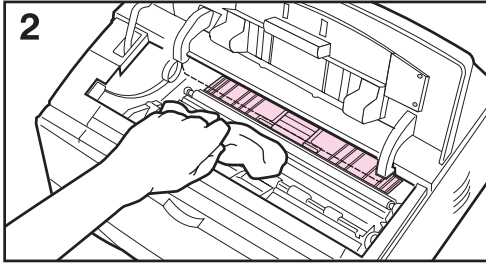

Caution

To prevent damage to the toner cartridge, do not expose it to light for more than a few minutes.

- 2 Wipe any dust or dirt off the paper feed guides (shaded areas) with a dry, lint-free cloth.

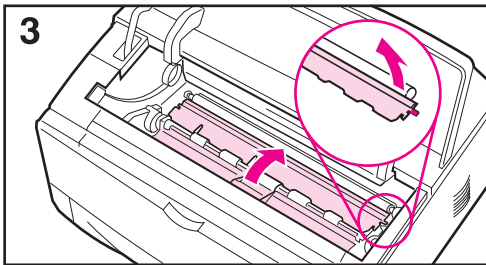

Note

If toner gets on your clothing, wipe it off with a dry cloth and wash clothing in cold water. (Hot water sets toner into fabric.)

- 3 Using the green handles, lift the paper access plates and wipe off any residue with a dry, lint-free cloth.

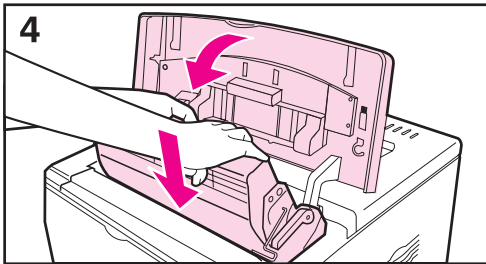

- 4 Close the paper access plates, replace the toner cartridge, close the top cover, plug in the power cord, and turn the printer on.

Using the Printer Cleaning Page

If toner specks appear on the front or back side of your print jobs, follow the procedure below.

From the printer's control panel, do the following:

- 1 Press **[Menu]** until PRINT QUALITY MENU appears.
- 2 Press **[Item]** until CREATE CLEANING PAGE appears.
- 3 Press **[Select]** to create the cleaning page.
- 4 Follow the instructions on the cleaning page to complete the cleaning process.

Note

In order for the cleaning page to work properly, print the page on copier grade paper (not bond or rough paper).

You might need to create a cleaning page more than once. When toner has been cleaned from inside the printer, shiny black spots will appear on the page's black strip. If white spots appear on the black strip, create a cleaning page again.

To ensure good print quality with certain types of paper, use the cleaning page every time the toner cartridge is replaced. If the cleaning page is frequently needed, try a different type of paper.

Problem Solving

Overview

This chapter will help you to troubleshoot and solve printer problems.

Clear paper jams:

Occasionally, paper can jam during printing. This section will help you to locate paper jams, properly clear them from the printer, and solve repeated paper jams.

Understand printer messages:

Many different messages can appear on the printer's control panel display. Some messages tell the printer's current status, such as `INITIALIZING`. Other messages require an action, such as `CLOSE TOP COVER`. Many of these messages are self-explanatory. However, some messages indicate a problem with the printer, or require further action or description. This section lists these types of messages, and tells what to do if a message persists.

Correct output quality problems:

The printer should produce print jobs of the highest quality. If print jobs do not look sharp and clear, defects such as lines, specks, or smears appear on the page, or paper is wrinkled or curled, use this section to troubleshoot and solve the output quality problem.

Determine printer problems:

Before you can fix a printer problem, you must understand where the problem lies. Use the flowchart in this section to determine the printer problem, and then follow the corresponding troubleshooting suggestions.

Check printer configuration:

From the printer, you can print information pages, which give details about the printer and its configuration.

Clearing Paper Jams

If the printer's control panel displays a paper jam message, look for paper in the locations indicated in Figure 22, then see the procedure for clearing the paper jam. You might need to look for paper in other locations than indicated in the paper jam message. If the location of the paper jam is not obvious, look first in the top cover area.

When clearing paper jams, be very careful not to tear the paper. If a small piece of paper is left in the printer, it could cause additional jams. If paper jams are a recurring problem, see page 78.

Note (A paper jam message might also display if the rear door is open.)

The top cover of the printer must be opened and then closed to clear a paper jam message.

Paper jams can occur at the following locations:

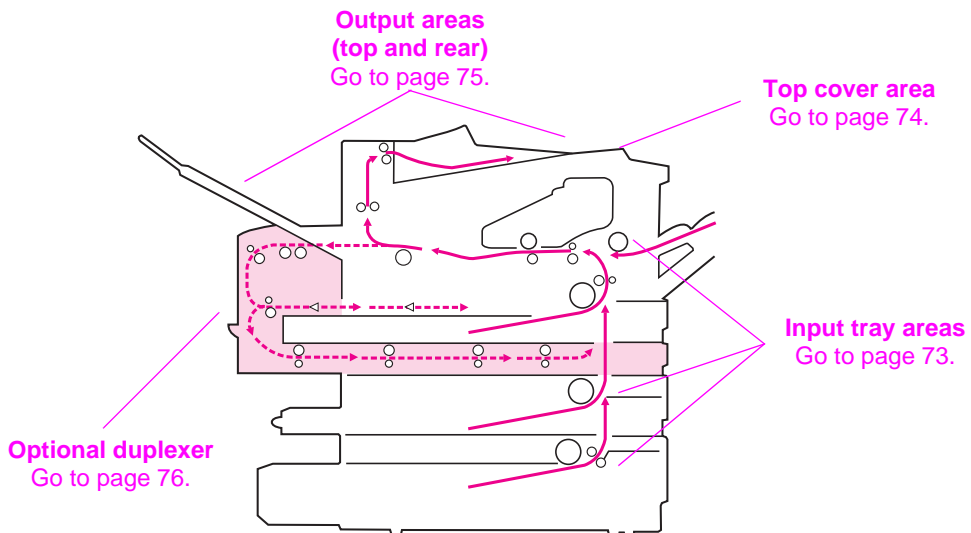
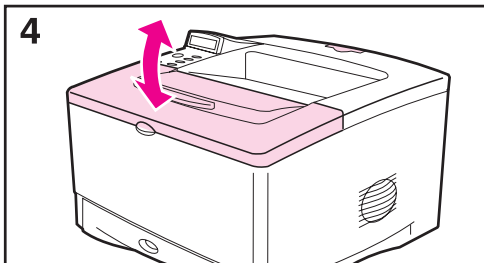
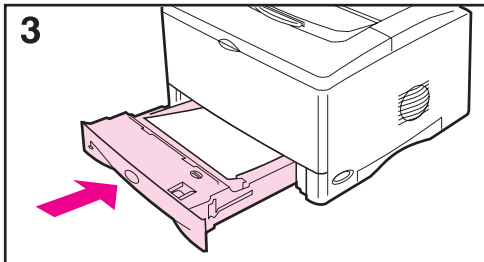
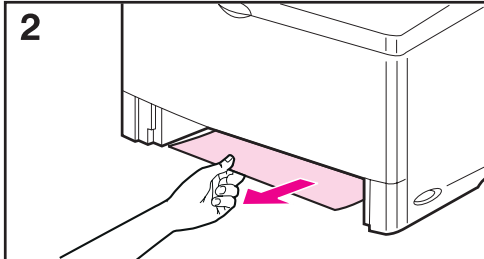
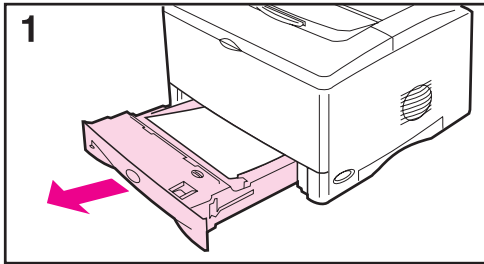

Figure 22 Paper Jam Locations

Note Loose toner might remain in the printer after a paper jam, but the toner should clear after a few sheets are printed.

Clearing Jams from the Input Tray Areas



Note

To remove paper from the Tray 1 area, slowly pull the paper out of the printer. For all other trays, follow the steps below.

1 Slide the tray out of the printer, and remove any damaged paper from the tray.

2 If the edge of the paper is visible in the feed area, slowly pull the paper down and out of the printer. If the paper is not visible, look in the top cover area (page 74).

Note

Do not force the paper if it will not move easily. If the paper is stuck in a tray, try removing it through the tray above (if applicable) or through the top cover area (page 74).

3 Before replacing the tray, make sure the paper is flat in the tray at all four corners and below the tabs on the guides.

4 Open and close the top cover to clear the paper jam message.

If a paper jam message persists, there is still paper in the printer. Look for paper in another location (page 72).

Clearing Jams from the Top Cover Area

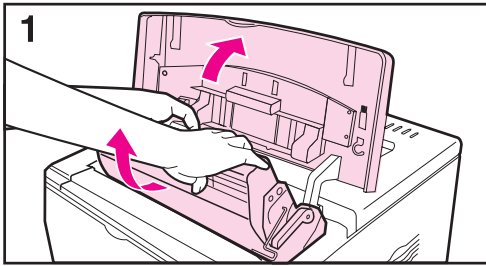

1 Open the top cover and remove the toner cartridge.

Caution

To prevent damage to the toner cartridge, do not expose it to light for more than a few minutes.

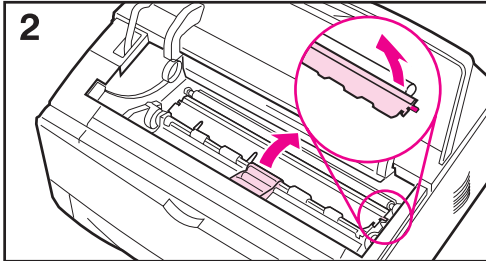

2 Use the green handles to lift the paper access plates.

3 Slowly pull the paper out of the printer. Do not tear the paper!

Note

Avoid spilling loose toner. Using a dry, lint-free cloth, clean any loose toner that might have fallen into the printer (page 67).

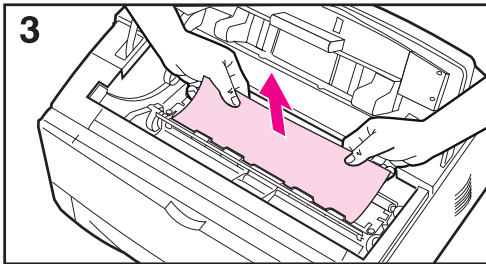

If loose toner falls into the printer, it might cause temporary problems with print quality. Loose toner should clear from the paper path after a few pages are printed.

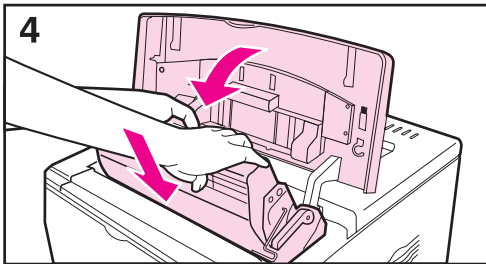

If toner gets on your clothing, wipe it off with a dry cloth and wash clothing in cold water. (Hot water sets toner into fabric.)

4 Close the paper access plates, replace the toner cartridge, and close the top cover.

If a paper jam message persists, there is still paper in the printer. Look for paper in another location (page 72).

Clearing Jams from the Output Areas

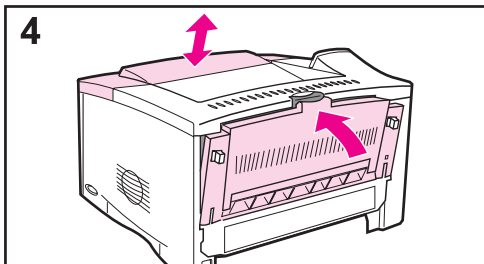
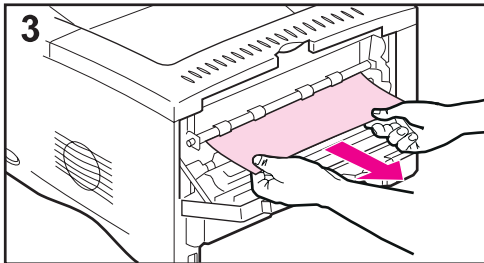
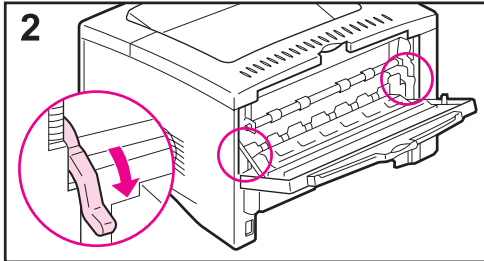
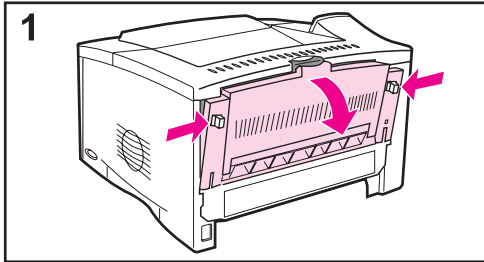

Note

If paper is jammed in the top output area, but most of the paper is still inside the printer, it is best to remove it through the rear door.

1 Push in the two gray latches to release the rear door.

2 Push down the green paper release levers.

3 Grasp both sides of the paper, and slowly pull the paper out of the printer. (There might be loose toner on the paper. Be careful not to spill it on yourself or into the printer.)

Note

If paper is difficult to remove, try opening the top cover and removing the toner cartridge to release pressure on the paper.

4 Close the rear door. (The levers automatically return to their original positions when the rear door is closed.) Open and close the top cover to clear the paper jam message.

If a paper jam message persists, there is still paper in the printer. Look for paper in another location (page 72).

Clearing Jams from the Optional Duplexer

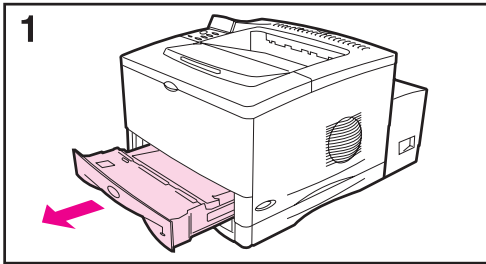

Look for jams in the following locations:

The Tray 2 area:

1 Slide Tray 2 out of the printer.

2 Slowly pull any paper out of the printer.

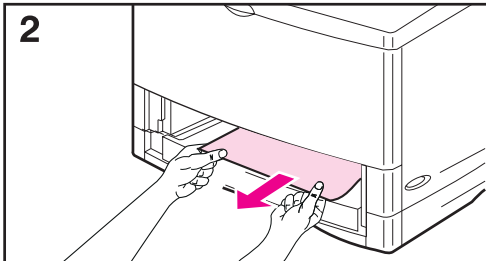

The duplexer's front cover:

3 From the front of the printer, grasp the duplexer's front cover (use the grip in the center), pull it straight toward you, and then lift it up to remove.

4 Slowly pull any paper out of the printer.

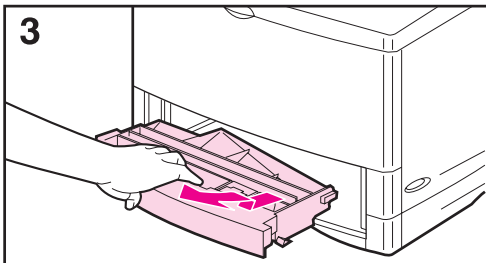

5 Replace the duplexer's front cover, and replace Tray 2.

Continued on the next page.

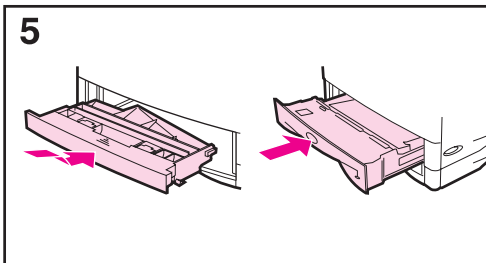
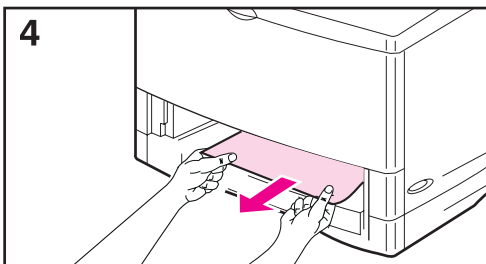

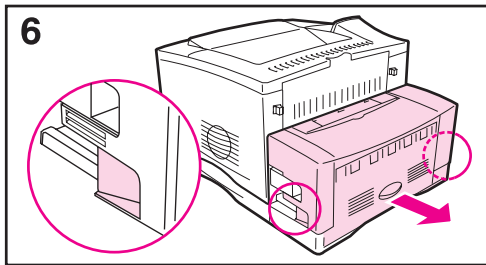

The rear section of the duplexer:

6 From the rear of the printer, use the handles on both sides of the duplexer to slide out the rear section until it stops.

7 Slowly pull any paper out of the duplexer.

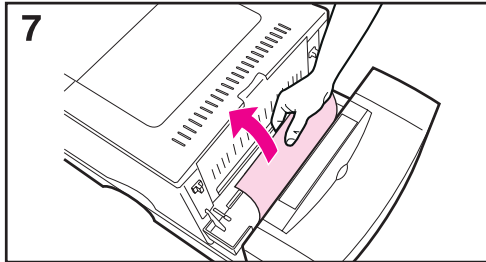

The duplexer's top cover:

8 Open the duplexer's top cover.

9 Slowly pull any paper out of the duplexer.

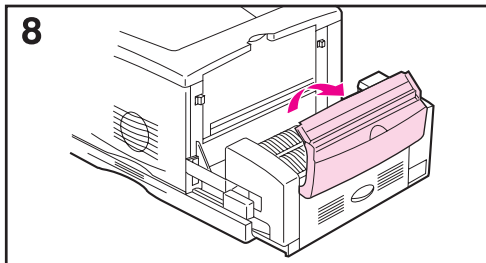

When all paper has been removed from the duplexer, continue with step 10 below:

10 Close the duplexer's top cover, and push the rear section of the duplexer back into the printer. Open and close the top cover to clear the paper jam message.

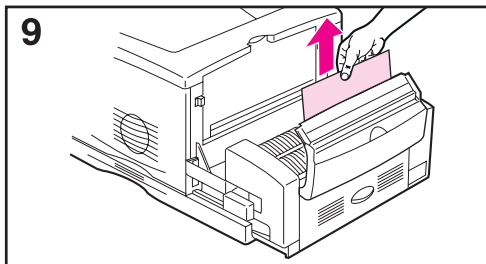

Note

To prevent further jams, make sure all tray covers are in place.

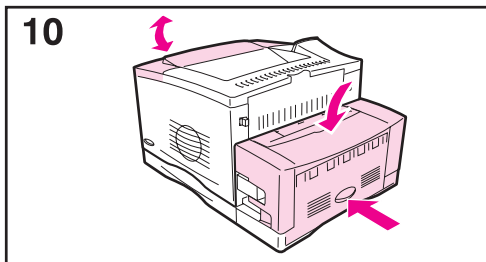

Solving Repeated Paper Jams

If paper jams occur frequently, try the following:

- Check all the paper jam locations. A piece of paper might be stuck somewhere in the printer. (See page 72.)
- Check that paper is correctly loaded in the trays, that the trays are correctly adjusted for the loaded paper size, and that the trays are not overfilled. (See the sections on loading paper, starting on page 30.)
- Check that all trays and paper handling accessories are completely inserted into the printer. (If a tray is opened during a print job, this might cause a paper jam.)
- Check that all covers and doors are closed. (If a cover or door is opened during a print job, this might cause a paper jam.)
- Try printing to a different output bin (page 26).
- The sheets might be sticking together. Try bending the stack to separate each sheet. Do not fan the stack.
- If you are printing from Tray 1, try feeding fewer sheets of paper or fewer envelopes at a time.
- If you are printing with the optional duplexer, make sure the cable tray is seated properly, and the Tray 2 cover is installed.
- Try turning the paper reforming setting on from the Configuration Menu in the printer's control panel (this will slow print speed). For more information, see page B-14.
- If you are printing small sizes (such as index cards), make sure the paper is oriented correctly in the tray (page 53).
- Turn over the stack of paper in the tray. Also try rotating the paper 180°.
- Try rotating paper (such as perforated or multi-sheet forms and labels) to feed through the printer from a different orientation (page 47).
- Check the quality of the paper being printed. Damaged or irregular paper should not be used.
- Use only paper that meets HP specifications (pages A-2 through A-13).
- Do not use paper that has already been used in a printer or copier. (Do not print on both sides of envelopes, transparencies, vellum, or labels.)
- Check that the power supplied to the printer is steady, and meets printer specifications (page A-17).
- Clean the printer (page 67).
- Contact an HP-authorized service or support provider to perform routine printer maintenance. (See the HP Support pages at the front of this user's guide.)

Understanding Printer Messages

The following table explains messages that might display on the printer's control panel. Printer messages and their meanings are listed in alphabetical order, with numbered messages following.

If a message persists:

- If a message persists requesting that you load a tray, or if a message indicates that a previous print job is still in the printer's memory, press **[Go]** to print or press **[Cancel Job]** to clear the job from the printer's memory.
- If a message persists after performing all of the recommended actions, contact an HP-authorized service or support provider. (See the HP Support pages at the front of this user's guide.)

Note

Not all messages are described in this user's guide (many are self-explanatory).

Some printer messages are affected by the Auto Continue and Clearable Warning settings from the Configuration Menu in the printer's control panel (page B-12).

Printer Messages

Message	Explanation or Recommended Action
ACCESS DENIED MENUS LOCKED	The printer control panel function you are trying to access has been locked to prevent unauthorized access. See your network administrator.
BAD DUPLEXER CONNECTION	The duplexer is not connected properly. Re-install the duplexer.
BAD OPT TRAY CONNECTION	The optional tray is not connected properly. Re-install the optional tray.
CANNOT DUPLEX REAR BIN OPEN	The printer cannot duplex because the rear output bin is open. Close the rear output bin.

Printer Messages (Continued)

Message	Explanation or Recommended Action
CHECK INPUT DEVICE alternates with PAPER PATH OPEN PLEASE CLOSE IT	The optional input tray cannot feed paper to the printer because a door or paper guide is open. Check the doors and paper guides.
CHOSEN LANGUAGE NOT AVAILABLE	A print job requested a printer language that does not exist in the printer. The job will not print and will be cleared from memory. Print the job using a driver for a different printer language, or add the requested language to the printer (if available). Press [Go] to continue.
DISK DEVICE FAILURE	The EIO disk had a critical failure and can no longer be used. Remove the EIO disk and replace it with a new one.
DISK FILE OPERATION FAILED	The requested operation could not be performed. You might have attempted an illegal operation, such as trying to download a file to a non-existent directory.
DISK FILE SYSTEM IS FULL	Delete files from the EIO disk and then try again, or add a flash disk DIMM. Download or delete files from HP JetAdmin, and download or delete fonts from HP FontSmart. (See the software help for more information.)
DISK IS WRITE PROTECTED	The EIO disk is protected, and no new files can be written to it. Disable the write protection through HP JetAdmin.
FLASH DEVICE FAILURE	The flash disk DIMM had a critical failure and no longer can be used. Remove the flash disk DIMM and replace it with a new one.
FLASH FILE OPERATION FAILED	The requested operation could not be performed. You might have attempted an illegal operation, such as trying to download a file to a non-existent directory.
FLASH FILE SYSTEM IS FULL	Delete files from the flash disk DIMM or add another one. Download or delete files from HP JetAdmin, and download or delete fonts from HP FontSmart. (See the software help for more information.)

Printer Messages (Continued)

Message	Explanation or Recommended Action
FLASH IS WRITE PROTECTED	The flash disk DIMM is protected, and no new files can be written to it. Disable the write protection through HP JetAdmin.
INPUT DEVICE CONDITION xx.yy	An input paper handling device has a condition that needs attention before printing can resume. See the documentation that came with the paper handling device for assistance.
INSTALL FRONT DUPLEX COVER	The printer is unable to print the current job, because the duplexer's front cover is not installed, or not inserted correctly. Re-insert the duplexer's front cover.
INSTALL TRAY x	The printer is unable to print the current job, because the specified tray (x) is open or not inserted correctly. Re-insert the specified tray.
LOADING PROGRAM <number> alternates with DO NOT POWER OFF	Programs and fonts can be stored on the printer's file system. At bootup time these entities are loaded into RAM. (These entities can take a long time to load into RAM depending on the size and number of entities being loaded.) The <number> specifies a sequence number indicating the current program being loaded.
MANUALLY FEED [TYPE] [SIZE]	Load the requested paper into Tray 1. Press [Go] if the desired paper is already loaded in Tray 1. Press [-Value+] to scroll through the available types and sizes. Press [Select] to accept the alternate type or size.
MEMORY FULL STORED DATA LOST	There is no available memory in the printer. The current job might not print correctly and some resources (such as downloaded fonts or macros) might have been deleted. You might want to add more memory to the printer (page C-1).

Printer Messages (Continued)

Message	Explanation or Recommended Action
MEMORY SETTINGS CHANGED	<p>The printer changed its memory settings because it did not have enough memory to use the previous settings for I/O Buffering and Resource Saving. This usually occurs after removing memory from the printer, adding a duplexer, or adding a printer language.</p> <p>You might want to change memory settings for I/O Buffering and Resource Saving (although default settings are usually best) or add more memory to the printer (page C-1).</p>
MEMORY SHORTAGE JOB CLEARED	<p>The printer did not have enough free memory to print the entire job. The remainder of the job will not print and will be cleared from memory.</p> <p>Press [Go] to continue.</p> <p>Change the Resource Saving setting from the printer's control panel (page C-6) or add more memory to the printer (page C-1).</p>
MEMORY SHORTAGE PAGE SIMPLIFIED	<p>The printer had to compress the job in order to fit it in available memory. Some data loss might have occurred.</p> <p>Press [Go] to continue.</p> <p>You might want to add more memory to the printer (page C-1).</p>
OFFLINE	<p>Press [Go] to place the printer online.</p>
PERFORM PRINTER MAINTENANCE	<p>To ensure optimum print quality, the printer prompts you to have routine maintenance performed every 150,000 pages. Contact an HP-authorized service or support provider to perform routine printer maintenance. (See the HP Support pages at the front of this user's guide.)</p>
RAM DISK DEVICE FAILURE	<p>The RAM disk had a critical failure and can no longer be used.</p> <p>Turn the printer off, and then turn the printer on to clear the message.</p>
RAM DISK FILE OPERATION FAILED	<p>The requested operation could not be performed. You might have attempted an illegal operation, such as trying to download a file to a non-existent directory.</p>

Printer Messages (Continued)

Message	Explanation or Recommended Action
RAM DISK FILE SYSTEM IS FULL	<p>Delete files and then try again, or turn the printer off, and then turn the printer on to delete all files on the device. (Delete files using HP JetAdmin, HP FontSmart, or another software utility. See the software help for more information.)</p> <p>If the message persists, increase the size of the RAM disk. Change the RAM disk size from the Configuration Menu in the printer's control panel (page B-13).</p>
RAM DISK IS WRITE PROTECTED	<p>The RAM disk is protected, and no new files can be written to it. Disable the write protection through HP JetAdmin.</p>
TRAY x EMPTY	<p>Load the empty tray (x) to clear the message.</p> <p>If you do not load the specified tray, the printer will continue printing from the next available tray, and the message will continue to display.</p>
TRAY x LOAD [TYPE] [SIZE]	<p>Load the requested paper into the specified tray (x). (See the sections on loading paper, starting on page 30.)</p> <p>Ensure that the trays are correctly adjusted for size. The size displayed on the front of the paper tray must match the size of paper loaded in the tray. The tray type settings (and size for Tray 1) must be set from the printer's control panel (page 60).</p> <p>If you are trying to print A4 or letter size paper, and this message appears, make sure the default paper size is set correctly from the Printing Menu in the printer's control panel.</p> <p>Press [Go] to print from the next available tray.</p> <p>Press [-Value+] to scroll through the available types and sizes. Press [Select] to accept the alternate type or size.</p>
UNSUPPORTED SIZE IN TRAY [YY]	<p>An external paper handling device detected an unsupported paper size. The printer will go offline until the condition is corrected.</p>
USE [TYPE] [SIZE] INSTEAD?	<p>If the requested paper size or type is not available, the printer asks if it should use another paper size or type instead.</p> <p>Press [-Value+] to scroll through the available types and sizes. Press [Select] to accept the alternate type or size.</p>
WAIT FOR PRINTER TO REINITIALIZE	<p>The RAM disk setting has been changed from the printer's control panel. This change will not take effect until the printer reinitializes.</p>

Message	Explanation or Recommended Action
13.× PAPER JAM [LOCATION]	<p>Remove jammed paper from the specified location (page 72). Open and close the top cover to clear the message.</p> <p>If the message persists after all jams have been cleared, a sensor might be stuck or broken. Contact an HP-authorized service or support provider. (See the HP Support pages at the front of this user's guide.)</p>
20 INSUFFICIENT MEMORY alternates with PRESS GO TO CONTINUE	<p>The printer received more data than can fit in its available memory. You might have tried to transfer too many macros, soft fonts, or complex graphics.</p> <p>Press [Go] to print the transferred data (some data might be lost), then simplify the print job or install additional memory (page C-1).</p>
21 PAGE TOO COMPLEX alternates with PRESS GO TO CONTINUE	<p>The data (dense text, rules, raster or vector graphics) sent to the printer was too complex.</p> <p>Press [Go] to print the transferred data. (Some data might be lost.)</p> <p>To print the job without losing data, from the Configuration Menu in the printer control panel, set PAGE PROTECT=ON, print the job, and then return PAGE PROTECT=AUTO. (For more information, see page B-12.) Do not leave PAGE PROTECT=ON; it might degrade performance.</p> <p>If this message appears often, simplify the print job.</p>
22 EIO × BUFFER OVERFLOW alternates with PRESS GO TO CONTINUE	<p>Too much data was sent to the EIO card in the specified slot (×). An improper communications protocol may be in use.</p> <p>Press [Go] to clear the message. (Data will be lost.)</p> <p>Check the host configuration. If this message persists, contact an HP-authorized service or support provider. (See the HP Support pages at the front of this user's guide.)</p>
22 PARALLEL I/O BUFFER OVERFLOW alternates with PRESS GO TO CONTINUE	<p>Too much data was sent to the parallel port.</p> <p>Check for a loose cable connection and be sure to use a high-quality cable (page 9). (Some non-HP parallel cables might be missing pin connections, or might otherwise not conform to the IEEE-1284 specification.)</p> <p>This error can occur if the driver you are using is not IEEE-1284 compliant. For best results, use an HP driver that came with the printer (page 15).</p> <p>Press [Go] to clear the error message. (Data will be lost.)</p> <p>If this message persists, contact an HP-authorized service or support provider. (See the HP Support pages at the front of this user's guide.)</p>

Message	Explanation or Recommended Action
22 SERIAL I/O BUFFER OVERFLOW alternates with PRESS GO TO CONTINUE	<p>Too much data was sent to the serial port.</p> <p>Make sure the correct serial pacing option is selected from the I/O Menu in the printer's control panel (page B-18).</p> <p>Print a menu map (page 100) and verify that the serial pacing item (from the I/O Menu in the printer's control panel) matches the setting on the computer. (For more information on interface settings, see page B-18.)</p> <p>Press [Go] to clear the error message. (Data will be lost.)</p> <p>If this message persists, contact an HP-authorized service or support provider. (See the HP Support pages at the front of this user's guide.)</p>
40 BAD SERIAL TRANSMISSION alternates with PRESS GO TO CONTINUE	<p>The printer encountered an error while transferring data from the computer.</p> <p>The error might have occurred for several reasons:</p> <ul style="list-style-type: none">• The computer was powered on or off while the printer was online.• There was a network problem (if applicable).• The printer's baud rate or parity was not the same as the computer's. (The baud rate tells the printer how fast information will be transferred from the computer to the printer.) Make sure the printer is set for the same baud rate as the computer. The serial baud rate setting can be accessed from the I/O Menu in the printer's control panel (page B-18). <p>Press [Go] to clear the error message and continue printing.</p>
40 EIO x BAD TRANSMISSION alternates with PRESS GO TO CONTINUE	<p>The connection has been broken between the printer and the EIO card in the specified slot.</p> <p>Press [Go] to clear the error message and continue printing.</p>
41.3 UNEXPECTED PAPER SIZE	<p>The paper size you are trying to print is not the same as the settings for the tray.</p> <p>Make sure that all trays are correctly adjusted for size. The size displayed on the front of the paper tray must match the size of paper loaded in the tray. (The printer will continue trying to print the job until size settings are correct.)</p> <p>If you are trying to print from Tray 1, make sure the printer's control panel setting for paper size is correctly configured (page B-3).</p> <p>After performing the actions above, press [Go]. The page containing the error will automatically be reprinted. (Or, you might want to press [Cancel Job] to clear the job from the printer's memory.)</p>

Printer Messages (Continued)

Message	Explanation or Recommended Action						
41.x PRINTER ERROR alternates with PRESS GO TO CONTINUE	<p>A temporary printing error occurred.</p> <p>Press [Go]. The page containing the error will automatically be reprinted.</p> <p>If this message persists, contact an HP-authorized service or support provider. (See the HP Support pages at the front of this user's guide.)</p>						
50.x FUSER ERROR	<p>An internal error has occurred. Turn the printer off, and then turn the printer on.</p> <p>If this message persists, contact an HP-authorized service or support provider. (See the HP Support pages at the front of this user's guide.)</p>						
51.x or 52.x PRINTER ERROR	<p>A temporary printing error occurred.</p> <p>Press [Go]. The page containing the error will automatically be reprinted.</p> <p>If this message persists, contact an HP-authorized service or support provider. (See the HP Support pages at the front of this user's guide.)</p>						
53.xy.zz PRINTER ERROR	<p>There is a problem with the printer's memory. The DIMM that caused the error will not be used. Values of x, y, and zz are as follows:</p> <table><tbody><tr><td>x = DIMM type</td><td>0 = ROM 1 = RAM</td></tr><tr><td>y = Device location</td><td>0 = Internal memory (ROM or RAM) 1 to 3 = DIMM slots 1, 2, or 3</td></tr><tr><td>zz = Error number</td><td></td></tr></tbody></table> <p>You might need to replace the specified DIMM.</p> <p>Turn the printer off, and then replace the DIMM that caused the error.</p> <p>If this message persists, contact an HP-authorized service or support provider. (See the HP Support pages at the front of this user's guide.)</p>	x = DIMM type	0 = ROM 1 = RAM	y = Device location	0 = Internal memory (ROM or RAM) 1 to 3 = DIMM slots 1, 2, or 3	zz = Error number	
x = DIMM type	0 = ROM 1 = RAM						
y = Device location	0 = Internal memory (ROM or RAM) 1 to 3 = DIMM slots 1, 2, or 3						
zz = Error number							
55 PRINTER ERROR alternates with PRESS GO TO CONTINUE	<p>A temporary printing error occurred.</p> <p>Press [Go]. The page containing the error will automatically be reprinted.</p> <p>If this message persists, contact an HP-authorized service or support provider. (See the HP Support pages at the front of this user's guide.)</p>						

Printer Messages (Continued)

Message	Explanation or Recommended Action
56.x, 57.x, 58.x, or 59.x PRINTER ERROR	A temporary printing error occurred. Turn the printer off, and then turn the printer on. If this message persists, contact an HP-authorized service or support provider. (See the HP Support pages at the front of this user's guide.)
62.x PRINTER ERROR	There is a problem with the printer's memory. The x value refers to the location of the problem: 0 = Internal memory 1 to 3 = DIMM slots 1, 2, or 3 You might need to replace the specified DIMM. If this message persists, contact an HP-authorized service or support provider. (See the HP Support pages at the front of this user's guide.)
64.x PRINTER ERROR	A temporary printing error occurred. Turn the printer off, and then turn the printer on. If this message persists, contact an HP-authorized service or support provider. (See the HP Support pages at the front of this user's guide.)
66.x9.zz INPUT DEVICE FAILURE alternates with CHECK CABLES AND CYCLE POWER	An error occurred in an external paper handling device. Press [Go] to clear the message. If the message will not clear, turn the printer off, and then turn the printer on. If this message persists, contact an HP-authorized service or support provider. (See the HP Support pages at the front of this user's guide.)
68 NVRAM ERROR CHECK SETTINGS	An error occurred in the printer's nonvolatile memory (NVRAM) and one or more printer settings has been reset to its factory default. Print a configuration page and check the printer settings to determine which values have changed (page 101). Hold down [Cancel Job] while turning the printer on. This will clean up the NVRAM by removing old areas that are not being used. If this message persists, contact an HP-authorized service or support provider. (See the HP Support pages at the front of this user's guide.)
68 NVRAM FULL CHECK SETTINGS	The printer's nonvolatile memory (NVRAM) is full. Some settings might have been reset to the factory defaults. Print a configuration page and check the printer settings to determine which values have changed (page 101). If this message persists, contact an HP-authorized service or support provider. (See the HP Support pages at the front of this user's guide.)

Printer Messages (Continued)

Message	Explanation or Recommended Action
69.x PRINTER ERROR	<p>A temporary printing error occurred.</p> <p>Turn the printer off, and then turn the printer on.</p> <p>If this message persists, contact an HP-authorized service or support provider. (See the HP Support pages at the front of this user's guide.)</p>
79.xxxxx PRINTER ERROR	<p>The printer detected an error. The numbers (xxxxx) indicate the specific type of error.</p> <p>Turn the printer off, and then turn the printer on. Try printing a job from a different software application. If the job prints, go back to the first application and try printing a different file. (If the message only appears with a certain software application or print job, contact the software vendor for assistance.)</p> <p>If the message persists with different software applications and print jobs, record the numbers that appear (xxxxx) and contact an HP-authorized service or support provider. (See the HP Support pages at the front of this user's guide.)</p>

Correcting Output Quality Problems

Use the examples below to determine which output quality problem you are experiencing, then see the following table to troubleshoot the problem.

Note

The examples below depict letter-size paper that has passed through the printer long-edge first. (If the paper has passed through the printer short-edge first, lines and repeating defects will run vertically rather than horizontally.)



Light Print or Fade

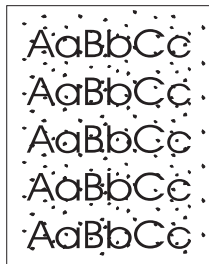

Toner Specks (front or back)

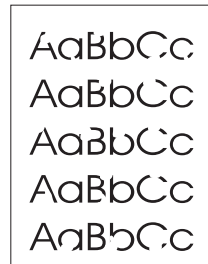

Dropouts

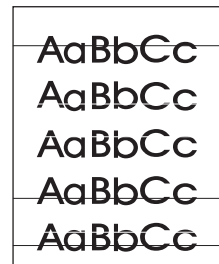

Lines



Gray Background



Toner Smear

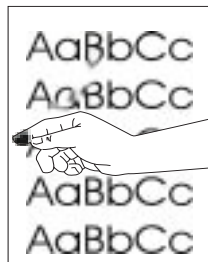

Loose Toner

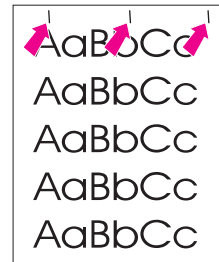

Repeating Defects

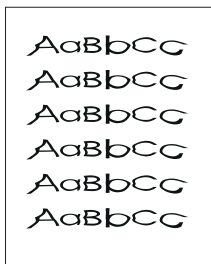

Misformed Characters

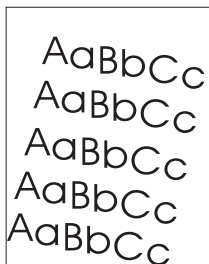

Page Skew

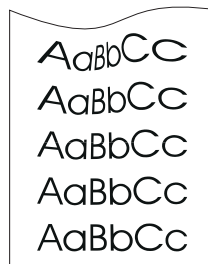

Curl or Wave

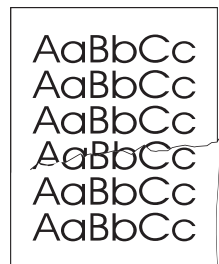

Wrinkles or Creases

Figure 23 Examples of Output Quality Problems

Light Print or Fade	Toner Specks	Dropouts	Lines	Gray Background	Toner Smear	Loose Toner	Repeating Defects	Misformed Characters	Page Skew	Curl or Wave	Wrinkles or Creases	Troubleshooting Steps (Follow the steps in the order they are listed.)
	✓		✓		✓	✓	✓				✓	1. Print a few more pages to see if the problem will correct itself.
	✓		✓		✓	✓	✓					2. Clean the inside of the printer (page 67) or use the printer's cleaning page (page 69).
✓		✓										3. Make sure EconoMode is off in the software and in the control panel (page B-6).
					✓				✓	✓	✓	4. Turn over the stack of paper in the tray. Also try rotating the paper 180°.
✓	✓	✓ ¹		✓	✓ ¹	✓ ¹		✓ ¹	✓	✓	✓	5. Check the paper (or other print media) type and quality (pages A-2 through A-13).
✓		✓		✓	✓				✓	✓	✓	6. Check the printer's environment (page A-17).
									✓		✓	7. Make sure paper is loaded correctly and that the guides fit properly against the paper stack. (See the sections on loading paper, starting on page 30.)
										✓	✓	8. Print to a different output bin (page 26).
✓		✓		✓								9. Adjust the toner density setting (page B-6).
									✓	✓	✓	10. From the Configuration Menu in the printer's control panel, turn the paper reforming setting on (page B-14).
		✓				✓						11. Change the fuser mode setting to High (page B-4) or choose rough paper type from the printer driver (page 60).
										✓	✓	12. Change the fuser mode setting to Low (page B-4).
✓		✓										13. Redistribute the toner in the toner cartridge (page 65).
✓		✓	✓	✓	✓		✓	✓				14. Install a new HP toner cartridge. (See instructions with the toner cartridge.)
	✓						✓					15. To alternate small and standard paper, from the Configuration Menu set SMALL PAPER SPEED=SLOW.
✓	✓	✓	✓	✓	✓	✓	✓	✓	✓	✓	✓	16. After trying all the steps suggested above, contact an HP-authorized service or support provider. (See the HP Support pages at the front of this user's guide.)

1. Paper might be too smooth.

Determining Printer Problems

Troubleshooting Flowchart

If the printer is not responding properly, use the flowchart to determine the problem. If the printer does not pass a step, follow the corresponding troubleshooting suggestions.

If you cannot resolve the problem after following the suggestions in this user's guide, contact an HP-authorized service or support provider. (See the HP Support pages at the front of this user's guide.)

Note

Macintosh users: For more troubleshooting information, see page 97.

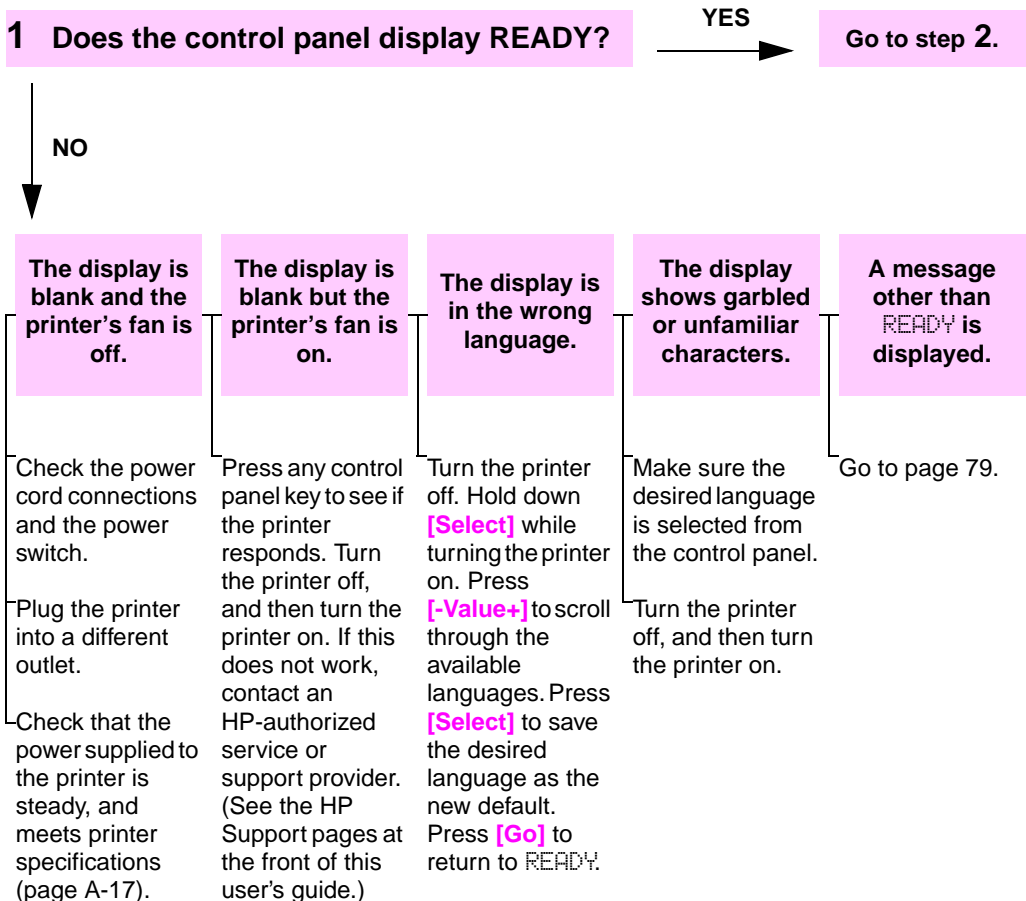

2 Can you print a configuration page?

YES

Go to step 3.

NO

Print a configuration page to verify that the printer is feeding paper correctly (page 101).

A configuration page does not print.

Check that all trays are properly loaded, adjusted, and installed in the printer. (See the sections on loading paper, starting on page 30.)

From the computer, check the print queue or print spooler to see if the printer has been paused. If there are problems with the current print job, or if the printer is paused, a configuration page will not print. (Press **[Cancel Job]** and try Step 2 again.)

A blank page prints.

Check that the sealing tape is not still in the toner cartridge. (See the getting started guide or the instructions that came with the toner cartridge.)

The toner cartridge might be empty. Install a new toner cartridge.

A message other than READY or PRINTING CONFIGURATION is displayed.

Go to page 79.

3 Can you print from a software application?

YES

Go to step 4

NO

Print a short document from a software application.

The job will not print.

A PS error page or list of commands prints.

- If the job will not print, and a message is displayed, see page 79.
- From the computer, check to see if the printer has been paused.
- If the printer is on a network, check that you are printing to the correct printer. To verify that it is not a network problem, connect the computer directly to the printer with a parallel cable, change the port to LPT1, and try to print.
- Check the interface cable connections. Disconnect and reconnect the cable at the computer and the printer.
- Test the cable by trying it on another computer (if possible).
- If you are using a parallel connection, make sure the cable is IEEE-1284 compliant (page A-19).
- If the printer is on a network, print a configuration page (page 101) and verify in the Protocol Information that the server name and the node name match the names in the printer driver.
- To verify that it is not a computer problem, print from another computer (if possible).
- Make sure the print job is being sent to the correct port (LPT1, or network printer port, for example).
- Check that you are using the proper printer driver (page 17).
- Reinstall the printer driver. (See the getting started guide.)
- Check that the port is configured and working properly. (One way to check this is to connect another printer to that port and print.)
- If printing with the PS driver, from the Printing Menu in the printer's control panel, set `PRINT PS ERRORS=ON`, then print the job again. If an error page prints, see the instructions in the next column.
- From the Configuration Menu in the printer's control panel, make sure that `PERSONALITY=AUTO` (page B-10).
- You might be missing a printer message that could help you solve the problem. From the Configuration Menu in the printer's control panel, temporarily turn the Clearable Warnings and Auto Continue settings off (page B-12) and then print the job again.

- The printer might have received a nonstandard PS code. From the Configuration Menu in the printer's control panel, set `PERSONALITY` to `PS` for this print job only. After the job has printed, return the setting to `AUTO` (page B-10).
- Make sure the print job is a PS job, and that you are using the PS driver.
- The printer might have received PS code when it is set to PCL. From the Configuration Menu, set `PERSONALITY` to `AUTO` (page B-10).

4 Does the job print as expected? (Continued on the following page.)

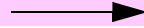

NO

Print is garbled or only a portion of the page prints.

Check that you are using the proper printer driver (page 18).

The data file sent to the printer might be corrupt. To test, try printing it on another printer (if possible), or try a different file.

Check the interface cable connections. Test the cable by trying it on another computer (if possible).

Replace the printer cable with a high-quality cable (page 9).

Reduce the job's complexity, print at a lower resolution (page B-5), or install more printer memory (page C-1).

You might be missing a printer message that could help you solve the problem. From the Configuration Menu in the printer's control panel, temporarily turn the Clearable Warnings and Auto Continue settings off (page B-12) and then print the job again.

Printing stops in the middle of the job.

[Cancel Job] might have been pressed.

Check that the power supplied to the printer is steady, and meets printer specifications (page A-17).

Print speed is slower than expected.

Simplify the print job.

Add more memory to the printer (page C-1).

Turn banner pages off. (See your network administrator.)

From the Configuration Menu in the printer's control panel, turn the paper reforming setting off (page B-14).

A control panel setting is not taking effect.

Check settings in the printer driver or software application. (Printer driver and software commands override control panel settings.)

Does the job print as expected? (continued)

YES

Go to step 5.

NO

The print job is not formatted correctly.

- Check that you are using the proper printer driver (page 18).
- Check the software settings. (See the software help.)
- Try a different font.
- Downloaded resources might have been lost. You might need to download them again.

Pages are not fed correctly or are damaged.

- Make sure paper is loaded correctly and that the guides are not too tight or too loose against the paper stack. (See the sections on loading paper, starting on page 30.)
- If you are having problems printing custom-size paper, see page 53.
- If pages are wrinkled or curled, or if the image is skewed on the page, see page 89.

There are print quality problems.

- Adjust the print resolution (page B-5).
- Check that REt is on (page B-5).
- Go to page 89.

5 Does the printer select the proper trays, output locations, and paper handling accessories?

YES

For other problems, check the Contents, the Index, or the printer software help.

NO

The printer pulls from the wrong tray.

Make sure paper trays are correctly configured for paper size and type (page 60). Print a configuration page to see current tray settings (page 101).

Make sure the tray selection (or paper type) in the printer driver or software application is set correctly. (The printer driver and software application settings override the printer's control panel settings.)

If you do not want to print from Tray 1, remove any paper loaded in the tray or change the TRAY 1 MODE setting to CASSETTE (page 58). By default, paper loaded in Tray 1 will be printed first.

If you want to print from Tray 1, but cannot select the tray from a software application, see page 58.

An optional accessory is not working properly.

Print a configuration page to verify that the accessory is installed properly and is functional (page 101).

Configure the printer driver for the installed accessories (see the software help).

Turn the printer off, and then turn the printer on.

Verify that you are using the correct optional accessory for the printer.

If the optional duplexer will not duplex, check that the rear output bin is closed.

If the optional duplexer will not duplex, you might need to install more memory (page C-1).

A message other than READY is displayed.

Go to page 79.

Troubleshooting Flowchart for Macintosh Users

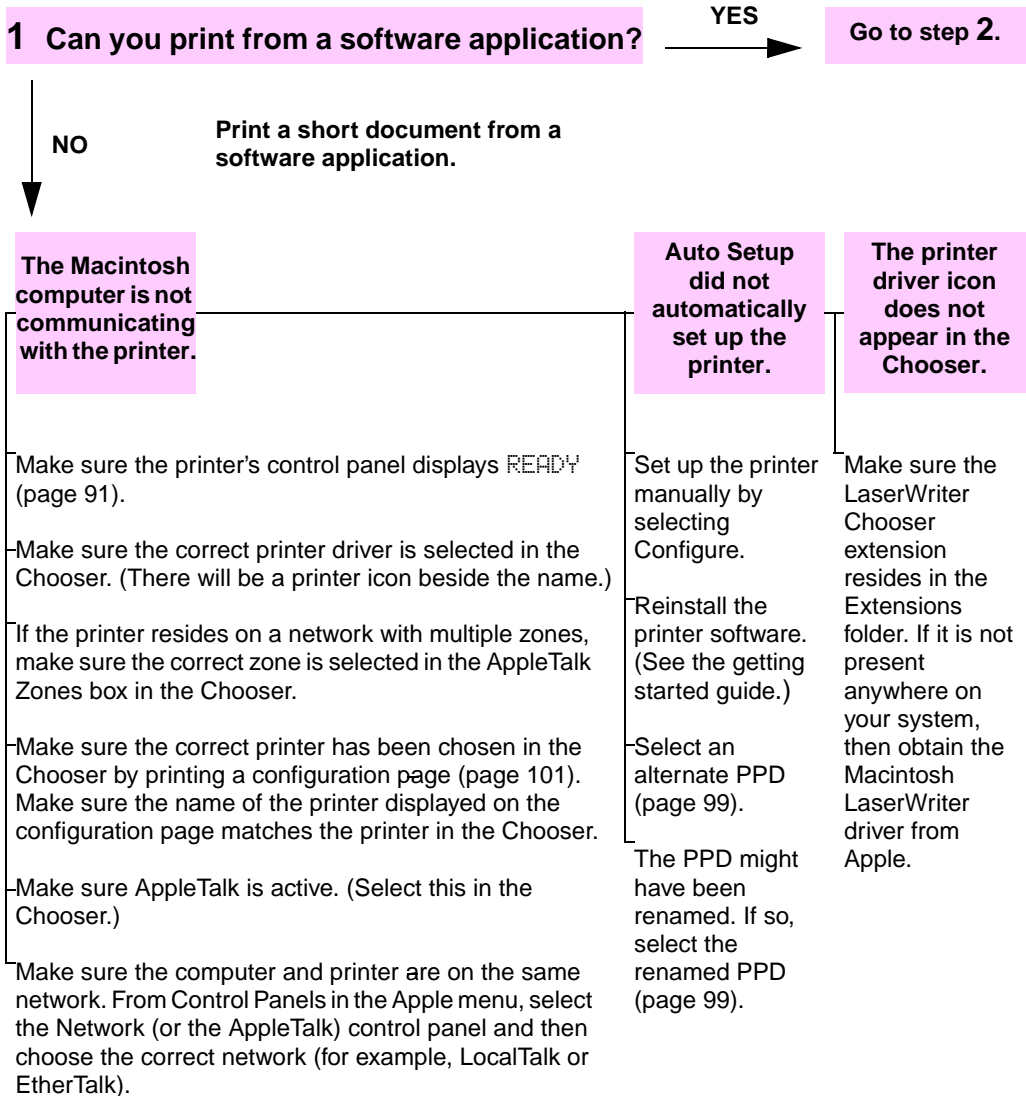

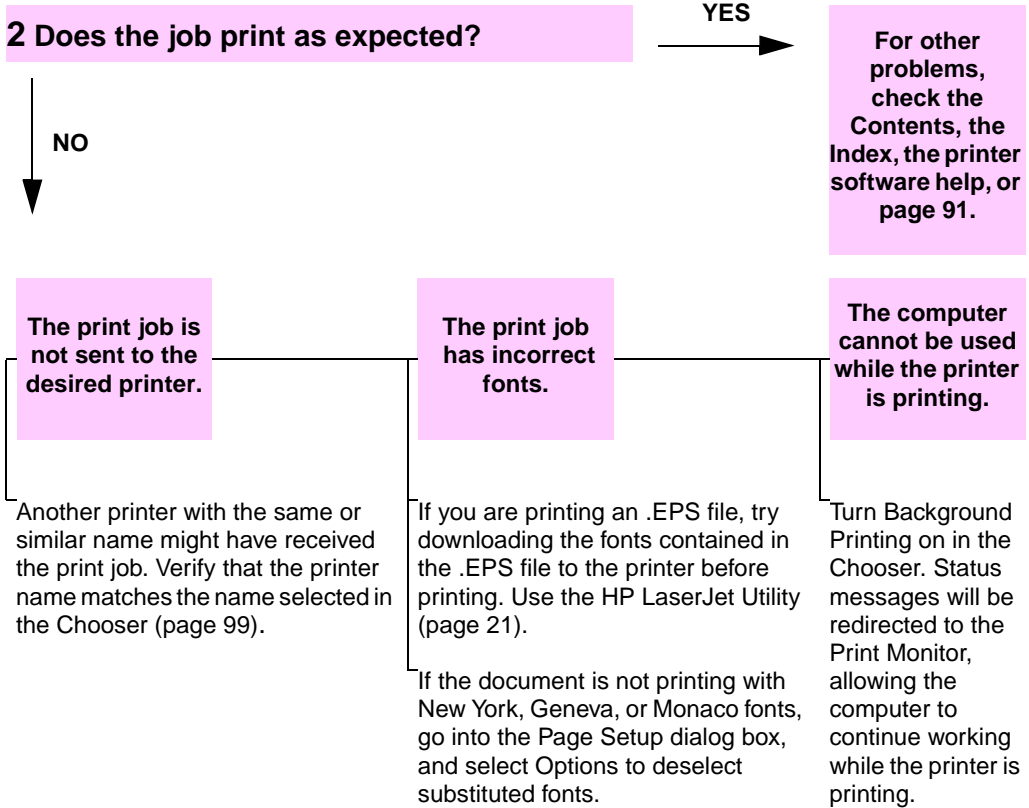

Selecting an Alternate PPD

- 1 Open the **Chooser** from the **Apple** menu.
- 2 Click the **LaserWriter** icon.
- 3 If you are on a network with multiple zones, select the zone in the **AppleTalk Zones** box where the printer is located.
- 4 Click the printer name you want to use in the **Select a PostScript Printer** box. (Double-clicking will immediately generate the next few steps.)
- 5 Click **Setup...** (This button might read **Create** for first-time setup.)
- 6 Click **Select PPD....**
- 7 Find the desired PPD in the list and click **Select**. If the desired PPD is not listed, choose one of the following options:
 - Select a PPD for a printer with similar features.
 - Select a PPD from another folder.
 - Select the generic PPD by clicking **Use Generic**. The generic PPD allows you to print, but limits your access to printer features.
- 8 In the **Setup** dialog box, click **Select**, and then click **OK** to return to the **Chooser**.

Note

If you manually select a PPD, an icon might not appear next to the selected printer in the **Select a PostScript Printer** box. In the **Chooser**, click **Setup**, click **Printer Info**, and then click **Update Info** to bring up the icon.

-
- 9 Close the **Chooser**.

Renaming the Printer

If you are going to rename the printer, do this before selecting the printer in the **Chooser**. If you rename the printer after selecting it in the **Chooser**, you will have to go back into the **Chooser** and reselect it.

Use the **Set Printer Name** feature in the **HP LaserJet Utility** to rename the printer.

Checking the Printer's Configuration

From the printer's control panel, you can print pages that give details about the printer and its current configuration. The following information pages are described here:

- Menu Map
- Configuration Page
- PCL or PS Font List

For a complete list of the printer's information pages, see the Information Menu in the printer's control panel (page B-2).

Menu Map

To see the current settings for the menus and items available in the control panel, print a control panel menu map:

- 1 Press **[Menu]** until INFORMATION MENU appears.
- 2 Press **[Item]** until PRINT MENU MAP appears.
- 3 Press **[Select]** to print the menu map.

You might want to store the menu map near the printer for reference. The content of the menu map varies, depending on the options currently installed in the printer. (Many of these values can be overridden from the printer driver or software application.)

For a complete list of control panel items and possible values, see page B-1. To change a control panel setting, see page 13.

Configuration Page

Use the configuration page to view current printer settings, to help troubleshoot printer problems, or to verify installation of optional accessories, such as memory (DIMMs), paper trays, and printer languages.

Note

If an HP JetDirect print server card is installed, a JetDirect configuration page will print out as well.

To print a configuration page:

- 1 Press **[Menu]** until INFORMATION MENU appears.
- 2 Press **[Item]** until PRINT CONFIGURATION appears.
- 3 Press **[Select]** to print the configuration page.

Figure 24 is a sample configuration page. Numbers in the sample printout match the numbers in the table. The content of the configuration page varies, depending on the options currently installed in the printer.

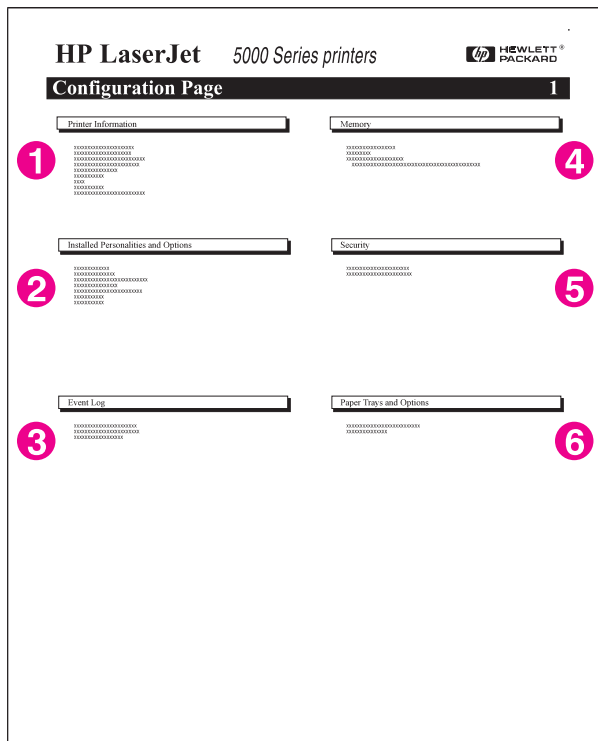

Figure 24 Sample Configuration Page

1	Printer Information	Lists the serial number, HP JetSend IP addresses, page counts, and other information for the printer.
2	Installed Personalities and Options	Lists all printer languages that are installed (such as PCL and PS) and lists options that are installed in each DIMM slot and EIO slot.
3	Event Log	Lists the number of entries in the log, the maximum number of entries viewable, and the last three entries.
4	Memory	Lists printer memory, PCL Driver Work Space (DWS), and I/O buffering and resource saving information.
5	Security	Lists the status of the printer's control panel lock, control panel password, and disk drive.
6	Paper Trays and Options	Lists the size settings for all trays and lists optional paper handling accessories that are installed.

PCL or PS Font List

Use the font lists to see which fonts are currently installed in the printer. (The font lists also show which fonts are resident on an optional hard disk or flash DIMM.)

To print a PCL or PS font list:

- 1 Press **[Menu]** until INFORMATION MENU appears.
- 2 Press **[Item]** until PRINT PCL FONT LIST or PRINT PS FONT LIST appears.
- 3 Press **[Select]** to print the font list.

The PS font list shows the PS fonts installed, and gives a sample of those fonts. The following describes the information that can be found on the PCL font list:

- **Font** gives the font names and samples.
- **Pitch/Point** indicates the pitch or point size of the font.
- **Escape Sequence** (a PCL programming command) is used to select the designated font. (See the legend at the bottom of the font list page.)

Note

For step-by-step instructions on using printer commands to select a font with DOS applications, see page D-7.

- **Font #** is the number used to select fonts from the printer's control panel (not the software application). Do not confuse the font # with the font ID, described below. The number indicates the DIMM slot where the font is stored.
 - **SOFT**: Downloaded fonts, which stay resident in the printer until other fonts are downloaded to replace them, or until the printer is turned off.
 - **INTERNAL**: Fonts that permanently reside in the printer.
- **Font ID** is the number you assign to soft fonts when you download them through software.

Service and Support

Hewlett-Packard Warranty Statement

HP PRODUCT	DURATION OF WARRANTY
HP LaserJet 5000, 5000 N, and 5000 GN printers	1-year, return to HP

- 1 HP warrants HP hardware, accessories, and supplies against defects in materials and workmanship for the period specified above. If HP receives notice of such defects during the warranty period, HP will, at its option, either repair or replace products which prove to be defective. Replacement products may be either new or like-new.
- 2 HP warrants that HP software will not fail to execute its programming instructions, for the period specified above, due to defects in material and workmanship when properly installed and used. If HP receives notice of such defects during the warranty period, HP will replace software media which does not execute its programming instructions due to such defects.
- 3 HP does not warrant that the operation of HP products will be uninterrupted or error free. If HP is unable, within a reasonable time, to repair or replace any product to a condition as warranted, customer will be entitled to a refund of the purchase price upon prompt return of the product.
- 4 HP products may contain remanufactured parts equivalent to new in performance or may have been subject to incidental use.
- 5 The warranty period begins on the date of the delivery or on the date of installation if installed by HP. If customer schedules or delays HP installation more than 30 days after delivery, warranty begins on the 31st day from delivery.

- 6** Warranty does not apply to defects resulting from (a) improper or inadequate maintenance or calibration, (b) software, interfacing, parts or supplies not supplied by HP, (c) unauthorized modification or misuse, (d) operation outside of the published environmental specifications for the product, or (e) improper site preparation or maintenance.
- 7** TO THE EXTENT ALLOWED BY LOCAL LAW, THE ABOVE WARRANTIES ARE EXCLUSIVE AND NO OTHER WARRANTY, WHETHER WRITTEN OR ORAL, IS EXPRESSED OR IMPLIED AND HP SPECIFICALLY DISCLAIMS THE IMPLIED WARRANTIES OF MERCHANTABILITY, SATISFACTORY QUALITY, AND FITNESS FOR A PARTICULAR PURPOSE.
- 8** HP will be liable for damage to tangible property per incident up to the greater of \$300,000 or the actual amount paid for the product that is the subject of the claim, and for damages for bodily injury or death, to the extent that all such damages are determined by a court of competent jurisdiction to have been directly caused by a defective HP product.
- 9** TO THE EXTENT ALLOWED BY LOCAL LAW, THE REMEDIES IN THIS WARRANTY STATEMENT ARE THE CUSTOMER'S SOLE AND EXCLUSIVE REMEDIES. EXCEPT AS INDICATED ABOVE, IN NO EVENT WILL HP OR ITS SUPPLIERS BE LIABLE FOR LOSS OF DATA OR FOR DIRECT, SPECIAL, INCIDENTAL, CONSEQUENTIAL (INCLUDING LOST PROFIT OR DATA), OR OTHER DAMAGE, WHETHER BASED IN CONTRACT, TORT, OR OTHERWISE.
- 10** FOR CONSUMER TRANSACTIONS IN AUSTRALIA AND NEW ZEALAND; THE WARRANTY TERMS CONTAINED IN THIS STATEMENT, EXCEPT TO THE EXTENT LAWFULLY PERMITTED, DO NOT EXCLUDE, RESTRICT OR MODIFY AND ARE IN ADDITION TO THE MANDATORY STATUTORY RIGHTS APPLICABLE TO THE SALE OF THIS PRODUCT TO YOU.

Service During and After the Warranty Period

- If printer hardware fails during the warranty period, contact an HP-authorized service or support provider. (See the HP Support pages at the front of this user's guide.)
- If printer hardware fails after the warranty period, and you have an HP Maintenance Agreement or HP Support Pack, request service as specified in the agreement.
- If you do not have an HP Maintenance Agreement or HP Support Pack, contact an HP-authorized service or support provider. (See the HP Support pages at the front of this user's guide.)

Limited Warranty for Toner Cartridge Life

Note

The warranty below applies to the toner cartridge that came with this printer.

This warranty supersedes all previous warranties (7/19/96).

HP toner cartridges are warranted to be free from defects in materials and workmanship until the HP toner is depleted. The warranty covers any defects or malfunctions in a new Hewlett-Packard toner cartridge.

How long does the coverage last?

The coverage lasts until the HP toner is depleted, at which time the warranty expires.

How do I know when the HP toner is running out?

The **TONER LOW** message on the printer's control panel display provides the first indication that toner is low. (Toner will likely run out in the next 100-300 sheets of paper.)

What will HP do?

HP will, at HP's option, either replace products which prove to be defective or refund the purchase price. If possible, please attach a print-out sample illustrating what the defective cartridge is printing.

What does this warranty not cover?

The warranty does not cover cartridges which have been refilled, are emptied, are abused, are misused, or are tampered with in any way.

How do I return the faulty cartridge?

In the event the cartridge proves to be defective, return the cartridge to the place of purchase, where the cartridge will be replaced (include a print sample illustrating the defect).

How does State, Province or Country Law apply?

This limited warranty gives you specific legal rights, and you may also have other rights which vary from state to state, province to province, or country to country. This limited warranty is the sole warranty on the HP toner cartridge and supersedes any other warranty relating to this product.

IN NO EVENT SHALL HEWLETT-PACKARD COMPANY BE LIABLE FOR ANY INCIDENTAL, CONSEQUENTIAL, SPECIAL, INDIRECT, PUNITIVE, OR EXEMPLARY DAMAGES OR LOST PROFITS FROM ANY BREACH OF THIS WARRANTY OR OTHERWISE.

Service Information Form

WHO IS RETURNING THE EQUIPMENT?		Date: _____
Person to contact:		Phone: () _____
Alternate contact:		Phone: () _____
Return shipping address:	Special shipping instructions:	
WHAT IS BEING SENT?		
Model name:	Model number:	Serial number:
Please attach any relevant printouts when returning equipment. DO NOT ship accessories (manuals, cleaning supplies, etc.) that are not required to complete the repair.		
WHAT NEEDS TO BE DONE? (Attach a separate sheet if necessary.)		
1. Describe the conditions of the failure. (What was the failure? What were you doing when the failure occurred? What software were you running? Is the failure repeatable?)		
2. If the failure is intermittent, how much time elapses between failures?		
3. Is the unit connected to any of the following? (Give manufacturer and model number.)		
Personal computer:	Modem:	Network:
4. Additional comments:		
HOW WILL YOU PAY FOR THE REPAIR?		
<input type="checkbox"/> Under warranty	Purchase/received date: _____ (Enclose proof of purchase or receiving document with original received date.)	
<input type="checkbox"/> Maintenance contract number:	_____	
<input type="checkbox"/> Purchase order number:	_____	
Except for contract and warranty service, a purchase order number and/or authorized signature must accompany any request for service. If standard repair prices do not apply, a minimum purchase order is required. Standard repair prices can be obtained by contacting an HP-authorized Repair Center.		
Authorized signature: _____	Phone: _____	
Billing address:	Special billing instructions:	

HP Software License Terms

ATTENTION: USE OF THE SOFTWARE IS SUBJECT TO THE HP SOFTWARE LICENSE TERMS SET FORTH BELOW. USING THE SOFTWARE INDICATES YOUR ACCEPTANCE OF THESE LICENSE TERMS. IF YOU DO NOT ACCEPT THESE LICENSE TERMS, YOU MAY RETURN THE SOFTWARE FOR A FULL REFUND. IF THE SOFTWARE IS BUNDLED WITH ANOTHER PRODUCT, YOU MAY RETURN THE ENTIRE UNUSED PRODUCT FOR A FULL REFUND.

The following License Terms govern your use of the accompanying Software unless you have a separate signed agreement with HP.

License Grant

HP grants you a license to Use one copy of the Software. "Use" means storing, loading, installing, executing, or displaying the Software. You may not modify the Software or disable any licensing or control features of the Software. If the Software is licensed for "concurrent use", you may not allow more than the maximum number of authorized users to Use the Software concurrently.

Ownership

The Software is owned and copyrighted by HP or its third party suppliers. Your license confers no title to, or ownership in, the Software and is not a sale of any rights in the Software. HP's third party suppliers may protect their rights in the event of any violation of these License Terms.

Copies and Adaptations

You may only make copies or adaptations of the Software for archival purposes or when copying or adaptation is an essential step in the authorized Use of the Software. You must reproduce all copyright notices in the original Software on all copies or adaptations. You may not copy the Software onto any public network.

No Disassembly or Decryption

You may not disassemble or decompile the Software unless HP's prior written consent is obtained. In some jurisdictions, HP's consent may not be required for limited disassembly or decompilation. Upon request, you will provide HP with reasonably detailed information regarding any disassembly or decompilation. You may not decrypt the Software unless decryption is a necessary part of the operation of the Software.

Transfer

Your license will automatically terminate upon any transfer of the Software. Upon transfer, you must deliver the Software, including any copies and related documentation, to the transferee. The transferee must accept these License Terms as a condition to the transfer.

Termination

HP may terminate your license upon notice for failure to comply with any of these License Terms. Upon termination, you must immediately destroy the Software, together with all copies, adaptations, and merged portions in any form.

Export Requirements

You may not export or reexport the Software or any copy or adaptation in violation of any applicable laws or regulations.

U.S. Government Restricted Rights

The Software and any accompanying documentation have been developed entirely at private expense. They are delivered and licensed as "commercial computer software" as defined in DFARS 252.227-7013 (Oct 1988), DFARS 252.211-7015 (May 1991), or DFARS 252.227-7014 (Jun 1995), as a "commercial item" as defined in FAR 2.101 (a), or as "Restricted computer software" as defined in FAR 52.227-19 (Jun 1987) (or any equivalent agency regulation or contract clause), whichever is applicable. You have only those rights provided for such Software and any accompanying documentation by the applicable FAR or DFARS clause or the HP standard software agreement for the product involved.

Worldwide Sales and Service Offices

Worldwide Sales and Service Offices

<p>Before calling an HP Sales and Service office, be sure to contact the appropriate Customer Support Center number listed in the front of this user's guide.</p>	<p>Argentina: Hewlett-Packard Argentina S.A. Montañeses 2140/50/60 1428 Buenos Aires Phone: (54) (1) 787-7100 Fax: (54) (1) 787-7213</p>	<p>Australia: Hewlett-Packard Australia Ltd. 31-41 Joseph Street Blackburn, VIC 3130 Phone: (61) (3) 272-2895 Fax: (61) (3) 898-7831</p> <p>Hardware Repair Center: Phone: (61) (3) 272-8000</p> <p>Extended Warranty Support: Phone: (61) (3) 272-2577</p> <p>Customer Information Center: Phone: (61) (3) 272-8000</p>
<p>Austria: Hewlett-Packard GmbH Lieblgasse 1 A-1222 Vienna Phone: (43) (1) 25000-555 Fax: (43) (1) 25000-500</p>	<p>Belgium: Hewlett-Packard Belgium S.A. NV Boulevard de la Woluwe-Woluwedal 100-102 B-1200 Brussels Phone: (32) (2) 778-31-11 Fax: (32) (2) 763-06-13</p>	<p>Brazil: Edisa Hewlett-Packard SA Alameda Rio Negro 750 06454-050 Alphaville - Barueri-SP Phone: (55) (11)- 7296-8000</p>
<p>Canada: Hewlett-Packard (Canada) Ltd. 17500 Trans Canada Highway South Service Road Kirkland, Québec H9J 2X8 Phone: (1) (514) 697-4232 Fax: (1) (514) 697-6941</p> <p>Hewlett-Packard (Canada) Ltd. 5150 Spectrum Way Mississauga, Ontario L4W 5G1 Phone: (1) (905) 206-4725 Fax: (1) (905) 206-4739</p>	<p>Chile: Hewlett-Packard de Chile Avenida Andres Bello 2777 of. 1 Los Condes Santiago, Chile</p>	<p>China: China Hewlett-Packard Co. Ltd. Level 5, West Wing Office China World Trade Center No. 1, Jian Guo Men Wai Avenue Beijing 100004 Phone: (86) (10) 6505-3888, x. 5450 Fax: (86) (10) 6505-1033</p> <p>Hardware Repair Center and Extended Warranty Support: Phone: (86) (10) 6262-5666 x. 6101/2 (86) (10) 6261-4167</p>
<p>Colombia: Hewlett-Packard Colombia Calle 100 No. 8A -55 Torre C Oficina 309 Bogota, Colombia</p>	<p>Czech Republic: Hewlett-Packard s. r. o. Novodvorská 82 CZ-14200 Praha 4 Phone: (42) (2) 613-07111 Fax: (42) (2) 471-7611</p>	<p>Denmark: Hewlett-Packard A/S Kongevejen 25 DK-3460 Birkerød Denmark Phone: (45) 99-1000 Fax: (45) 4281-5810</p>

Worldwide Sales and Service Offices (Continued)

<p>Far East Region: Hewlett-Packard Asia Pacific Ltd. 17-21/F Shell Tower, Times Square 1 Matheson Street, Causeway Bay Hong Kong Phone: (852) 2599-7777 Fax: (852) 2506-9261</p> <p>Hardware Repair Center: Phone: (852) 2599-7000</p> <p>Extended Warranty Support: Phone: (852) 2599-7000</p> <p>Customer Information Center: Phone: (852) 2599-7066</p>	<p>Finland: Hewlett-Packard Oy Piispankalliontie 17 FIN-02200 Espoo Phone: (358) (9) 887-21 Fax: (358) (9) 887-2477</p>	<p>France: Hewlett-Packard France 42 Quai du Point du Jour F-92659 Boulogne Cedex Phone: (33) (146) 10-1700 Fax: (33) (146) 10-1705</p>
<p>Germany: Hewlett-Packard GmbH Herrenberger Strasse 130 71034 Böblingen Phone: (49) (180) 532-6222 (49) (180) 525-8143 Fax: (49) (180) 531-6122</p>	<p>Greece: Hewlett-Packard Hellas 62, Kifissias Avenue GR-15125 Maroussi Phone: (30) (1) 689-6411 Fax: (30) (1) 689-6508</p>	<p>Hungary: Hewlett-Packard Magyarország Kft. Erzsébet királyné útja 1/c. H-1146 Budapest Phone: (36) (1) 343-0550 Fax: (36) (1) 122-3692</p> <p>Hardware Repair Center: Phone: (36) (1) 343-0312</p> <p>Customer Information Center: Phone: (36) (1) 343-0310</p>
<p>India: Hewlett-Packard India Ltd. Paharpur Business Centre 21 Nehru Place New Delhi 110 019 Phone: (91) (11) 647-2311 Fax: (91) (11) 646-1117</p> <p>Hardware Repair Center and Extended Warranty Support: Phone: (91) (11) 642-5073 (91) (11) 682-6042</p>	<p>Italy: Hewlett-Packard Italiana SpA Via Giuseppe di Vittorio, 9 Cernusco Sul Naviglio I-20063 (Milano) Phone: (39) (2) 921-21 Fax: (39) (2) 921-04473</p>	<p>Japan: Hewlett-Packard Japan, Ltd. 3-29-21 Takaido-higashi Suginami-ku, Tokyo 168 Phone: (81) (3) 3335-8333 Fax: (81) (3) 3335-8338</p> <p>Hardware Repair Center: Phone: (81) (4) 7355-6660 Fax: (81) (4) 7352-1848</p>
<p>Korea: Hewlett-Packard Korea 25-12, Yoido-dong, Youngdeungpo-ku Seoul 150-010 Phone: (82) (2) 769-0114 Fax: (82) (2) 784-7084</p> <p>Hardware Repair Center: Phone: (82) (2) 3270-0700 (82) (2) 707-2174 (DeskJet) (82) (2) 3270-0710 (Hardware)</p> <p>Extended Warranty Support: Phone: (82) (2) 3770-0365 (Bench) (82) (2) 769-0500 (Onsite)</p>	<p>Latin American Headquarters: 5200 Blue Lagoon Drive, Suite 950 Miami, FL 33126 USA Phone: (1) (305) 267-4220</p>	<p>México: Hewlett-Packard de México, S.A. de C.V. Prolongación Reforma No. 700 Lomas de Santa Fe 01210 México, D.F. Phone: 011-525-265-3330 Outside Mexico City Phone: 01-800-22147</p>

Worldwide Sales and Service Offices (Continued)

<p>Middle East/Africa: ISB HP Response Center Hewlett-Packard S.A. Rue de Veyrot 39 P.O. Box 364 CH-1217 Meyrin - Geneva Switzerland Phone: (41) (22) 780-4111</p>	<p>Netherlands: Hewlett-Packard Nederland BV Startbaan 16 NL-1187 XR Amstelveen Postbox 667 NL-1180 AR Amstelveen Phone: (31) (020) 606-87-51 Fax: (31) (020) 547-7755</p>	<p>New Zealand: Hewlett-Packard (NZ) Limited Ports of Auckland Building Princes Wharf, Quay Street P.O. Box 3860 Auckland Phone: (64) (9) 356-6640 Fax: (64) (9) 356-6620</p> <p>Hardware Repair Center and Extended Warranty Support: Phone: (64) (9) 0800-733547</p> <p>Customer Information Center: Phone: (64) (9) 0800-651651</p>
<p>Norway: Hewlett-Packard Norge A/S Postboks 60 Skøyen Drammensveien 169 N-0212 Oslo Phone: (47) 2273-5600 Fax: (47) 2273-5610</p>	<p>Poland: Hewlett-Packard Polska Al. Jerozolimskic 181 02-222 Warszawa Phone: (48-22) 608-77-00 Fax: (48-22) 608-76-00</p>	<p>Russia: AO Hewlett-Packard Business Complex Building #2 129223, Moskva, Prospekt Mira VVC Phone: (7) (95) 928-6885 Fax: (7) (95) 974-7829</p>
<p>Singapore: Hewlett-Packard Singapore (Sales) Pte Ltd 450 Alexandra Road Singapore (119960) Phone: (65) 275-3888 Fax: (65) 275-6839</p> <p>Hardware Repair Center and Customer Information Center: Phone: (65) 272-5300</p> <p>Extended Warranty Support: Phone: (65) 272-5333</p>	<p>Spain: Hewlett-Packard Española, S.A. Carretera de la Coruña km 16.500 E-28230 Las Rozas, Madrid Phone: (34) (1) 626-1600 Fax: (34) (1) 626-1830</p>	<p>Sweden: Hewlett-Packard Sverige AB Skalholtsgatan 9 S-164 97 Kista Phone: (46) (8) 444-2000 Fax: (46) (8) 444-2666</p>
<p>Switzerland: Hewlett-Packard (Schweiz) AG In der Luberzen 29 CH-8902 Urdorf/Zürich Phone: (41) (084) 880-11-11 Fax: (41) (1) 753-7700</p>	<p>Taiwan: Hewlett-Packard Taiwan Ltd. 8th Floor 337, Fu-Hsing North Road Taipei, 10483 Phone: (886) (02) 717-0055 FAX: (886) (02) 514-0276</p> <p>Hardware Repair Center, call: North (886) (02) 717-9673 Central (886) (04) 327-0153 South (886) (080) 733-733</p> <p>Extended Warranty Support Contact: Phone: (886) (02) 714-8882</p>	<p>Thailand: Hewlett-Packard (Thailand) Ltd. 23-25/f Vibulthani Tower II 2199 Rama 4 Rd, Klongton Klintoey, Bangkok 10110 Thailand Phone: (66) (2) 666-3900-34 Fax: (66) (2) 666-3935-37</p> <p>Hardware Repair Center and Extended Warranty Support Contact: Phone: (66) (2) 661-3900 x. 6001/ 6002</p> <p>Customer Information Center: Phone: (66) (2) 661-3900 x. 3211 Fax: (66) (2) 661-3943</p>
<p>Turkey: Hewlett-Packard Company Bilgisayar Ve ölçüm Sistemleri AS 19 Mayıs Caddesi Nova Baran Plaza Kat: 12 80220 Sisli-Istanbul Phone: (90) (212) 224-5925 Fax: (90) (212) 224-5939</p>	<p>United Kingdom: Hewlett-Packard Ltd. Cain Road Bracknell Berkshire RG12 1HN Phone: (44) (134) 436-9222 Fax: (44) (134) 436-3344</p>	<p>Venezuela: Hewlett-Packard de Venezuela S.A. Los Ruices Norte 3A Transversal Edificio Segre Caracas 1071 Phone: (58) (2) 239-4244 Fax: (58) (2) 239-3080</p>

Specifications

Overview

This appendix includes:

- Paper specifications
- Printer specifications
- Cable specifications

Paper Specifications

HP LaserJet printers produce excellent print quality. This printer accepts a variety of media, such as cut-sheet paper (including recycled paper), envelopes, labels, transparencies, vellum, and custom-size paper. Properties such as weight, grain, and moisture content are important factors affecting printer performance and output quality.

The printer can use a variety of paper and other print media in accordance with the guidelines in this manual. Paper that does not meet these guidelines may cause the following problems:

- poor print quality
- increased paper jams
- premature wear on the printer, requiring repair

Note

For best results, use only HP brand paper and print media. Hewlett-Packard Company cannot recommend the use of other brands. Because they are not HP products, HP cannot influence or control their quality.

It is possible for paper to meet all of the guidelines in this manual and still not produce satisfactory results. This might be the result of improper handling, unacceptable temperature and humidity levels, or other variables over which Hewlett-Packard has no control.

Before purchasing a large quantity of paper, make sure it meets the requirements specified in this user's guide and in the *HP LaserJet Printer Family Paper Specification Guide*. (To order the guide, see page 10.) Always test paper before purchasing a large quantity.

Caution

Using paper outside HP specifications may cause problems for the printer, requiring repair. This repair is not covered by the Hewlett-Packard warranty or service agreements.

Supported Sizes and Weights of Paper

Tray 1	Dimensions ¹	Weight	Capacity ²
Minimum Size (custom)	3 by 5 in (76 by 127 mm)	16 to 53 lb (60 to 199 g/m ²)	100 sheets of 20 lb (75 g/m ²) paper
Maximum Size (custom)	12.28 by 18.5 in (312 by 470 mm)		
Transparencies	Same as minimum and maximum paper sizes listed above.	Thickness: 0.0039 in to 0.0045 in (0.099 to 0.114 mm)	75 transparencies
Labels		Thickness: 0.005 in to 0.007 in (0.127 mm to 0.178 mm)	50 labels
Envelopes		20 to 28 lb (75 to 105 g/m ²)	10 envelopes

1. The printer supports a wide range of paper sizes. Check the printer software for supported sizes. To print custom-size paper, see page 50.
2. Capacity may vary depending on paper weight and thickness, and environmental conditions.

Tray 2 or Optional 250-Sheet Tray	Dimensions ¹	Weight	Capacity ²
Letter	8.5 by 11 in (216 by 279 mm)	16 to 28 lb (60 to 105 g/m ²)	250 sheets of 20 lb (75 g/m ²) paper
A4	8.3 by 11.7 in (210 by 297 mm)		
Executive	7.25 by 10.5 in (184 by 267 mm)		
Legal	8.5 by 14 in (216 by 356 mm)		
B5 (JIS)	7.2 by 10 in (182 by 257 mm)		
A5	5.8 by 8.2 in (148 by 210 mm)		
11 x 17	11 by 17 in (279 by 432 mm)		
A3	11.7 by 16.5 in (297 by 420 mm)		
B4 (JIS)	10.1 by 14.3 in (257 by 364 mm)		

1. The printer supports a wide range of media sizes. Check the printer software for supported sizes.
2. Capacity may vary depending on media weight and thickness, and environmental conditions.

500-Sheet Tray (Optional)	Dimensions ¹	Weight	Capacity ²
Letter Letter-R ³	8.5 by 11 in (216 by 279 mm)	16 to 28 lb (60 to 105 g/m ²)	500 sheets of 20 lb (75 g/m ²) paper
A4 A4-R ³	8.3 by 11.7 in (210 by 297 mm)		
Executive	7.25 by 10.5 in (184 by 267 mm)		
Legal	8.5 by 14 in (216 by 356 mm)		
B5 (ISO)	6.9 by 9.9 in (176 by 250 mm)		
B5 (JIS)	7.2 by 10 in (182 by 257 mm)		
A5	5.8 by 8.2 in (148 by 210 mm)		
11 x 17	11 by 17 in (279 by 432 mm)		
A3	11.7 by 16.5 in (297 by 420 mm)		
B4 (JIS)	10.1 by 14.3 in (257 by 364 mm)		
Custom ⁴	5.8 by 8.2 to 11.7 by 16.5 in OR 11 by 17 in (148 by 210 to 297 by 419 OR 280 by 432 mm)		

1. The printer supports a wide range of media sizes. Check the printer software for supported sizes.
2. Capacity may vary depending on media weight and thickness, and environmental conditions.
3. To print rotated paper, see page 47.
4. To print custom-size paper, see page 50.

Optional Duplex Printing Accessory (duplexer)	Dimensions ¹	Weight
Minimum	5.8 by 8.3 inches (148 by 210 mm)	16 to 28 lb (60 to 105 g/m ²)
Maximum	11.7 by 17 inches (297 by 432 mm)	

1. The printer supports a wide range of media sizes. Check the printer software for supported sizes.

Supported Types of Paper

The printer supports the following types of paper:

- plain
- letterhead
- prepunched
- bond
- color
- rough
- vellum
- preprinted
- transparency
- labels
- recycled
- card stock
- user-defined (5 types)

Guidelines for Using Paper

For best results, use conventional 20 lb (75 g/m²) paper. Make sure the paper is of good quality, and free of cuts, nicks, tears, spots, loose particles, dust, wrinkles, voids, and curled or bent edges.

If you are unsure what type of paper you are loading (such as bond or recycled), check the label on the package of paper.

Some paper causes print quality problems, jamming, or damage to the printer.

Symptom	Problem with Paper	Solution
Poor print quality or toner adhesion. Problems with feeding.	Too moist, too rough, too smooth, or embossed; faulty paper lot.	Try another kind of paper, between 100-250 Sheffield, 4-6% moisture content.
Dropouts, jamming, curl.	Stored improperly.	Store paper flat in its moisture-proof wrapping.
Increased gray background shading.	Too heavy.	Use lighter paper. Open the rear output bin.
Excessive curl. Problems with feeding.	Too moist, wrong grain direction or short-grain construction.	Open the rear output bin. Use long-grain paper. Set <code>PAPER_REFORMING=ON</code> (page B-14). Set <code>FUSER_MODE=LOW</code> (page B-4).
Jamming, damage to printer.	Cutouts or perforations.	Do not use paper with cutouts or perforations.
Problems with feeding.	Ragged edges.	Use good quality paper.

Note

Do not use letterhead paper that is printed with low-temperature inks, such as those used in some types of thermography.

Do not use raised letterhead.

The printer uses heat and pressure to fuse toner to the paper. Make sure that any colored paper or preprinted forms use inks that are compatible with the printer's temperature (392° F or 200° C for 0.1 second).

Paper Weight Equivalence Table

Use this table to determine approximate equivalent points in weight specifications other than U.S. bond weight. For example, to determine the equivalent of 20 lb U.S. bond weight paper in U.S. cover weight, locate the bond weight (in row 3, second column) and scan across the row to the cover weight (in the fourth column). The equivalent is 28 lb.

Shaded areas indicate a standard weight for that grade.

	U.S. Post Card ¹ thickness (mm)	U.S. Bond Weight (lb)	U.S. Text/ Book Weight (lb)	U.S. Cover Weight (lb)	U.S. Bristol Weight (lb)	U.S. Index Weight (lb)	U.S. Tag Weight (lb)	Europe Metric Weight (g/m ²)	Japan Metric Weight (g/m ²)
1		16	41	22	27	33	37	60	60
2		17	43	24	29	35	39	64	64
3		20	50	28	34	42	46	75	75
4		21	54	30	36	44	49	80	80
5		22	56	31	38	46	51	81	81
6		24	60	33	41	50	55	90	90
7		27	68	37	45	55	61	100	100
8		28	70	39	49	58	65	105	105
9		32	80	44	55	67	74	120	120
10		34	86	47	58	71	79	128	128
11		36	90	50	62	75	83	135	135
12	.18	39	100	55	67	82	91	148	148
13	.19	42	107	58	72	87	97	157	157
14	.20	43	110	60	74	90	100	163	163
15	.23	47	119	65	80	97	108	176	176
16		53	134	74	90	110	122	199	199

1. U.S. Post Card measurements are approximate. Use for reference only.

Labels

Caution

To avoid damaging the printer, use only labels recommended for use in laser printers.

If you have problems printing labels, use Tray 1 and open the rear output bin.

Never print on the same sheet of labels more than once.

Label Construction

When selecting labels, consider the quality of each component:

- **Adhesives:** The adhesive material should be stable at 392° F (200° C), the printer's maximum temperature.
- **Arrangement:** Only use labels with no exposed backing between them. Labels can peel off sheets with spaces between the labels, causing serious jams.
- **Curl:** Prior to printing, labels must lie flat with no more than 0.5 inch (13 millimeters) of curl in any direction.
- **Condition:** Do not use labels with wrinkles, bubbles, or other indications of separation.

To print sheets of labels, see page 44.

Transparencies

Transparencies used in the printer must be able to withstand 392° F (200° C), the printer's maximum temperature. Close the rear output bin to print transparencies to the top output bin.

Caution

To avoid damaging the printer, use only transparencies recommended for use in laser printers.

If you have problems printing transparencies, use Tray 1.

To print transparencies, see page 46.

Vellum

Vellum is special lightweight paper similar to parchment. Print vellum from Tray 1 only, and open the rear output bin. Do not print on both sides of vellum.

Vellum used in the printer must be able to withstand 392° F (200° C), the printer's maximum temperature. To print vellum, see page 55.

Envelopes

Envelope Construction

Envelope construction is critical. Envelope fold lines can vary considerably, not only between manufacturers, but also within a box from the same manufacturer. Successful printing on envelopes depends upon the quality of the envelopes. When selecting envelopes, consider the following components:

- **Weight:** The weight of the envelope paper should not exceed 28 lb (105 g/m²), or jamming may result.
- **Construction:** Prior to printing, envelopes should lie flat with less than 0.25 inch (6 mm) curl, and should not contain air. (Envelopes that trap air may cause problems.)
- **Condition:** Make sure envelopes are not wrinkled, nicked, or otherwise damaged.
- **Sizes in Tray 1:** From 3 by 5 inches (76 by 127 mm) to 12.28 by 18.5 inches (312 by 470 mm).

Always print envelopes from Tray 1 (page 42). To prevent envelopes from wrinkling or jamming, open the rear output bin.

Envelopes with Double-Side-Seams

Double-side-seam construction has vertical seams at both ends of the envelope rather than diagonal seams. This style may be more likely to wrinkle. Be sure the seam extends all the way to the corner of the envelope as illustrated below.

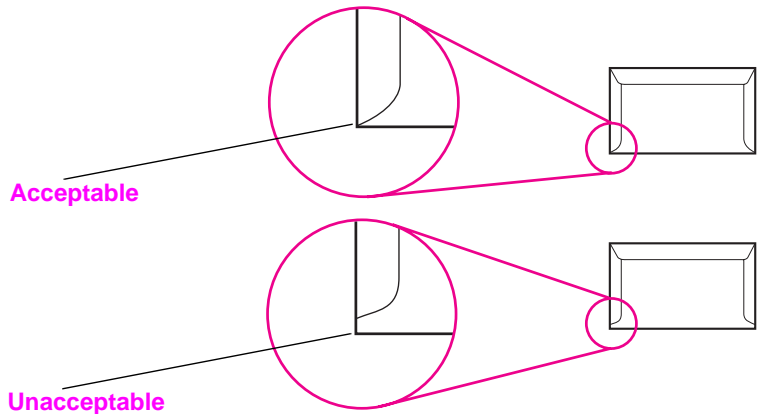

Figure A-1 Envelopes with Double-Side-Seams

Envelopes with Adhesive Strips or Flaps

Envelopes with a peel-off adhesive strip or with more than one flap that folds over to seal must use adhesives compatible with the heat and pressure in the printer. The extra flaps and strips might cause wrinkling, creasing, or jams.

Envelope Margins

The following table gives typical address margins for a Commercial #10 or DL envelope.

Type of Address	Top Margin	Left Margin
Return Address	0.6 in (15 mm)	0.6 in (15 mm)
Delivery Address	2 in (51 mm)	3.5 in (89 mm)

Note

For the best print quality, position margins no closer than 0.6 inch (15 millimeters) from the edges of the envelope.

Envelope Storage

Proper storage of envelopes helps contribute to good print quality. Envelopes should be stored flat. If air is trapped in an envelope, creating an air bubble, then the envelope may wrinkle during printing.

Card Stock and Heavy Paper

Many types of card stock can be printed from Tray 1, including index cards and postcards. Some card stock performs better than others because its construction is better suited for feeding through a laser printer.

For optimum printer performance, do not use paper heavier than 53 lb (199 g/m²) in Tray 1 or 28 lb (105 g/m²) in other trays. Paper that is too heavy might cause misfeeds, stacking problems, paper jams, poor toner fusing, poor print quality, or excessive mechanical wear.

Note

Printing on heavier paper may be possible if the tray is not filled to capacity, and paper with a smoothness rating of 100-180 Sheffield is used.

Card Stock Construction

- **Smoothness:** 36-53 lb (135-199 g/m²) card stock should have a smoothness rating of 100-180 Sheffield. 16-36 lb (60-135 g/m²) card stock should have a smoothness rating of 100-250 Sheffield.
- **Construction:** Card stock should lie flat with less than 0.2 inch (5 millimeters) of curl.
- **Condition:** Make sure card stock is not wrinkled, nicked, or otherwise damaged.
- **Sizes:** Use only card stock within the following size ranges:
 - minimum: 3 by 5 inches (76 by 127 mm)
 - maximum: 12.28 by 18.5 inches (312 by 470 mm)

Note

Before loading card stock in Tray 1, make sure it is regular in shape and not damaged. Also, make sure the cards are not stuck together.

Card Stock Guidelines

- If cards curl or jam, try printing from Tray 1 and opening the rear output bin.
- Set margins at least 0.08 inch (2 mm) away from the edges of the paper.

Printer Specifications

Physical Dimensions

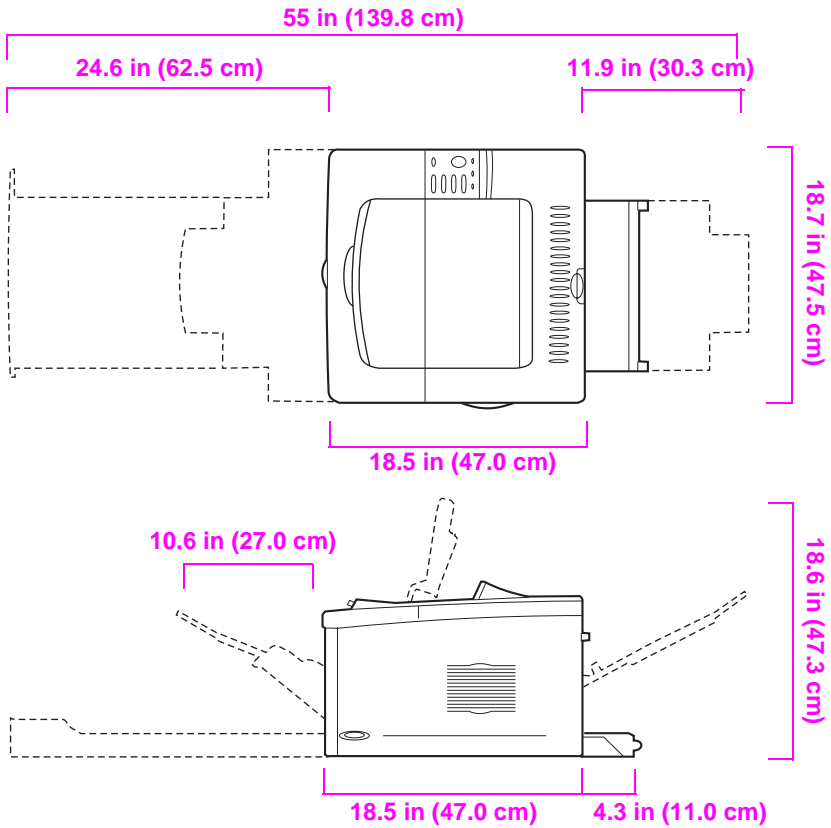

Figure A-2 HP LaserJet 5000 Printer Dimensions (top and side views)

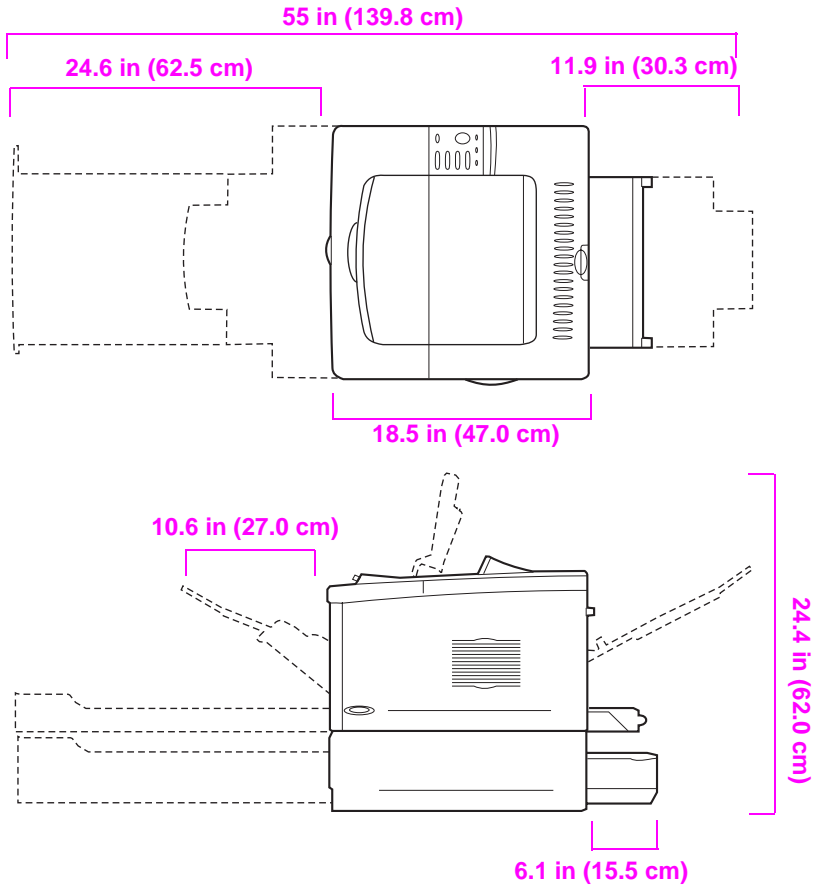

Figure A-3 HP LaserJet 5000 N/5000 GN Printer Dimensions (top and side views)

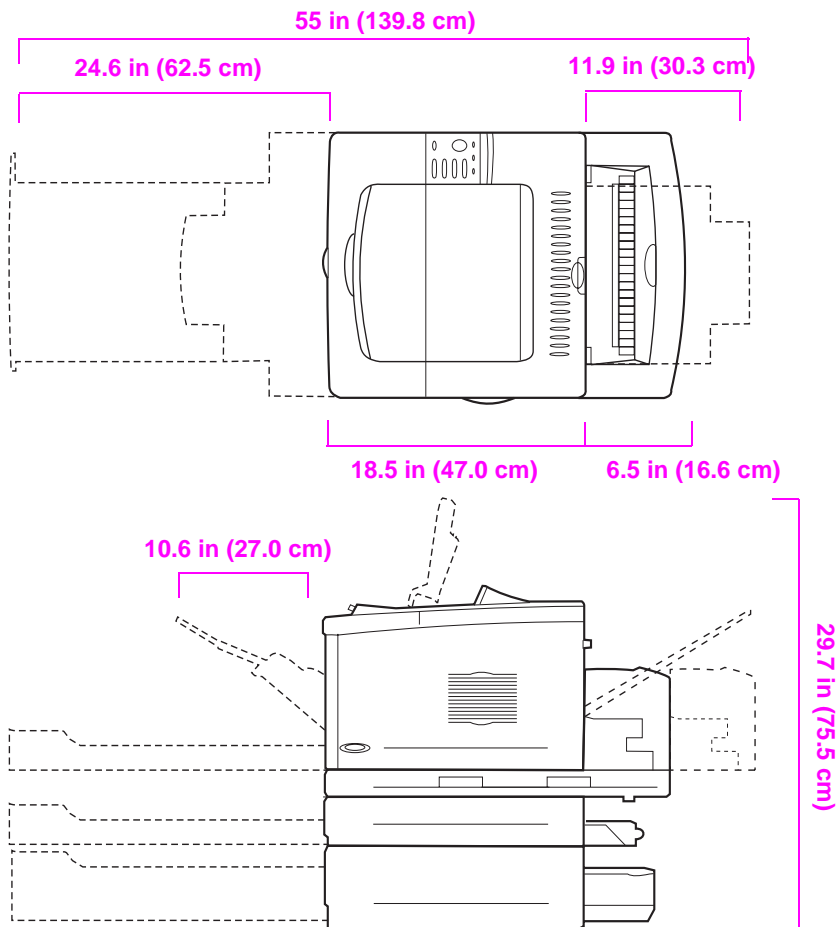

Figure A-4 Maximum Accessories Configuration (top and side views)

Printer Weight (Without Toner Cartridge)

- HP LaserJet 5000 printer: 50 lb (23 kg)
- HP LaserJet 5000 N/5000 GN printers: 75 lb (34 kg)
- HP LaserJet 5000 GN printer with duplexer and optional 250-sheet feeder: 114 lb (52 kg)

Environmental Specifications

Electrical Specifications

Printer State	Power Consumption (average, in watts)
Printing	365
Standby	40
PowerSave (default activation time 30 minutes)	27
Off	0

Minimum Recommended Circuit Capacity

100-127 Volt	10.5 amps
220-240 Volt	5.3 amps

Power Requirements (Acceptable Line Voltage)

100-127 Volt	50-60 Hz
220-240 Volt	50-60 Hz

Acoustic Emissions (Per ISO 9296)

Printer State	Sound Power ¹
Printing, 16 pages per minute (ppm)	$L_{wad} = 6.6$ bels (A)
Printing, 8 ppm	$L_{wad} = 6.3$ bels (A)
PowerSave	$L_{wad} = 4.4$ bels (A)

1. You might want to install printers with sound power $L_{wad} \geq 6.3$ bels (A) or more in a separate room or cubicle.

General Specifications

Operating temperature	50-91° F (10-32° C)
Relative Humidity	20-80%
Speed, in pages per minute (ppm)	16 ppm
Expandable Memory	Up to 100 MB total, combining standard and accessory memory DIMMs.

Serial Cable Specifications

Serial communication is simply the transmission of data one bit at a time. With just one bit to transmit at a time, data can be transferred with a simple electrical circuit consisting of only two wires. In this fashion, an eight-bit byte is transmitted one bit at a time and the individual bits are reassembled into the original byte on the receiving end. Bit transmission occurs from the least significant bit to the most significant bit.

Data Terminal Equipment (DTE)	Transmit on pin 2 and receive on pin 3. A printer is typically a DTE device.
Data Communications Equipment (DCE)	Transmit on pin 3 and receive on pin 2. A modem is typically a DCE device.
Asynchronous Communication	Asynchronous communication or start/stop transmission is the concept of enclosing a character with a start and stop bit. The RS-232 specification defines the standards for asynchronous serial communication.
Parity	Parity is a method of error checking at the bit level.
HP LaserJet Serial Data Format	Transmission is asynchronous, with one start bit, eight data bits and one stop bit. Parity is not used. HP LaserJet printers are DTE devices.
Serial Interface Protocol (handshaking)	Handshaking is the method by which the flow of data between two devices is controlled. The two methods of flow control that are used by HP LaserJet printers are software flow control, in which one device controls another by the content of the data, and hardware flow control, in which one device can control another by changing the voltage on a wire.
Software Flow Control (software handshaking)	Xon/Xoff is a data stream handshake protocol that sends Xon (DC1; 11 Hex) to the computer from the printer's transmit data pin when the printer is able to accept data and sends Xoff (DC3; 13 Hex) when the printer is not ready for data.
Hardware Flow Control (hardware handshaking)	By definition, hardware handshaking is performed when two programs manipulate RS-232 control pins-DTR, DSR, RTS, and CTS to achieve a hardware-based form of flow control. In DTR/DSR handshaking, the sender asserts DTR (Data Terminal Ready) before sending the first character in a stream of data and waits for DSR (Data Set Ready) to be asserted in return. RTS/CTS handshaking is similar, but uses the Request To Send and Clear To Send pins rather than Data Terminal Ready. In either case, the sender delays transmitting data until the receiver is ready.

Hewlett-Packard offers the following serial cables and adapter for use with the printer:

HP Part Number	Description
C2932A	9 to 9-pin M/F RS-232 Serial Cable, 3m
C2933A	9 to 25-pin M/F RS-232 Serial Cable, 3m
C2809A	9 to 25-pin M/F Serial Cable Adapter

With the C2809A serial cable adapter installed on the printer, you can connect a 25-pin cable connector to the printer. The adapter pin connections are shown below.

25 to 9 Pin Adapter (C2809A)

Standard DB-25 (female adapter end)	Printer DB-9 (male adapter end)
2- Transmit Data	2- Transmit Data
3- Receive Data	3- Receive Data
6- Data Set Ready	4- Data Set Ready
7- Signal Ground	5- Signal Ground
20- Data Terminal Ready	6- Data Terminal Ready

DB-9 Serial Cable Pin Outs

Computer DB-9	Printer DB-9 (male cable end)
2- Receive Data	2- Transmit Data
3- Transmit Data	3- Receive Data
4- Data Terminal Ready	4- Data Set Ready
5- Ground	5- Ground
6- Data Set Ready	6- Data Terminal Ready
8- Clear to Send	8- Data Terminal Ready

DB-25 Serial Cable Pin Outs

Computer DB-25	Printer DB-9 (male cable end)
3- Receive Data	2- Transmit Data
2- Transmit Data	3- Receive Data
20- Data Terminal Ready	4- Data Set Ready
7- Ground	5- Ground
6- Data Set Ready	6- Data Terminal Ready
5- Clear to Send	8- Data Terminal Ready

Note

The pin outs for the computer end are typical pin numbers. The actual pin numbers for your computer may be different. Check the documentation for your computer to verify the proper pin outs.

Pins not shown are not used by the printer.

Control Panel Menus

Overview

You can perform most routine printing tasks from the computer through the printer driver or software application. This is the most convenient way to control the printer, and will override the printer's control panel settings. See the help files associated with the software, or for more information on accessing the printer driver, see page 17.

You can also control the printer by changing settings in the printer's control panel. Use the control panel to access printer features not supported by the printer driver or software application.

Note

Printer driver and software commands override the printer's control panel settings.

You can print a menu map from the control panel that shows the **current** printer configuration (page 13). This appendix lists all the items and **possible** values for the printer. (Default values are listed in the "Item" column.)

Additional menu items can appear in the control panel, depending on the options currently installed in the printer.

Information Menu

This menu contains printer information pages that give details about the printer and its configuration. To print an information page, scroll to the desired page and press **[Select]**.

Information Menu

Item	Explanation
PRINT MENU MAP	The menu map shows the layout and current settings of the control panel menu items. For more information, see page 100.
PRINT CONFIGURATION	The configuration page shows the printer's current configuration. If an HP JetDirect print server card is installed (HP LaserJet 5000 N and 5000 GN printers), a JetDirect configuration page will print out as well. For more information, see page 101.
PRINT PCL FONT LIST	The PCL font list shows all the PCL fonts currently available to the printer. For more information, see page 103.
PRINT PS FONT LIST	The PS font list shows all the PS fonts currently available to the printer. For more information, see page 103.
PRINT FILE DIRECTORY	This item appears only when a mass storage device (such as an optional flash DIMM or hard disk) containing a recognized file system is installed in the printer. The file directory shows information for all installed mass storage devices. For more information, see page C-1.
PRINT EVENT LOG	The event log lists printer events or errors.
SHOW EVENT LOG	This item allows you to view the most recent printer events on the control panel display. Press [-Value+] to scroll through the event log entries.
PRINT PAPER PATH TEST	The paper path test can be used to verify that the paper path is working properly, or to troubleshoot problems with a type of paper. Choose the input tray, output bin, duplexer (if available), and number of copies.

Paper Handling Menu

When paper handling settings are correctly configured through the control panel, you can print by choosing the type and size of paper from the printer driver or software application. For more information, see page 60.

Some items in this menu (such as duplex and manual feed) can be accessed from a software application, or from the printer driver (if the appropriate driver is installed). Printer driver and software application settings override control panel settings. For more information, see page 56.

Paper Handling Menu

Item	Values	Explanation
TRAY 1 MODE= FIRST	FIRST CASSETTE	Determine how the printer will use Tray 1. FIRST: If paper is loaded in Tray 1, the printer will pull paper from that tray first. CASSETTE: A paper size must be assigned to Tray 1 using the TRAY 1 SIZE option (the next item in this menu when TRAY 1 MODE= CASSETTE). This allows Tray 1 to be used as a reserved tray. For more information, see page 58.
TRAY 1 SIZE= LETTER	For supported paper sizes, see page A-3.	This item appears only when TRAY 1 MODE= CASSETTE. Set the value to correspond with the paper size currently loaded in Tray 1.
TRAY 1 TYPE= PLAIN	For supported paper types, see page A-6.	This item appears only when TRAY 1 MODE= CASSETTE. Set the value to correspond with the paper type currently loaded in Tray 1.
TRAY 2 TYPE= PLAIN	For supported paper types, see page A-6.	Set the value to correspond with the paper type currently loaded in Tray 2.
TRAY 3 TYPE= PLAIN	For supported paper types, see page A-6.	This item appears only when a third paper tray is installed. Set the value to correspond with the paper type currently loaded in Tray 3.
TRAY 4 TYPE= PLAIN	For supported paper types, see page A-6.	This item appears only when a fourth paper tray is installed. Set the value to correspond with the paper type currently loaded in Tray 4.

Paper Handling Menu (Continued)

Item	Values	Explanation
MANUAL FEED=OFF	OFF ON	Feed the paper manually from Tray 1, rather than automatically from a tray. When MANUAL FEED=ON and Tray 1 is empty, the printer goes offline when it receives a print job and displays MANUALLY FEED [PAPER SIZE]. For more information, see page 59.
DUPLEX=OFF	OFF ON	This item appears only when an optional duplexer is installed. Set the value to ON to print on both sides (duplex) or OFF to print on one side (simplex) of a sheet of paper. For more information, see page 35.
BINDING= LONG EDGE	LONG EDGE SHORT EDGE	This item appears only when an optional duplexer is installed and the duplex option is on. Choose the binding edge when duplexing (printing on both sides of paper). For more information, see page 35.
OVERRIDE A4/LETTER=NO	NO YES	Choose YES to print on letter size paper when an A4 job is sent, but no A4 size paper is loaded in the printer (or to print on A4 size paper when a letter job is sent, but no letter paper is loaded in the printer).
CONFIGURE FUSER MODE MENU=NO	NO YES	Configure the fuser mode associated with each paper type. (This is only necessary if you are experiencing problems printing on certain paper types.) NO: The fuser mode menu items are not accessible. YES: Additional items appear (see below). Note To see the default fuser mode for each paper type, select YES, scroll back to the Information Menu, and print a menu map (page B-2).
[TYPE]= NORMAL	NORMAL LOW HIGH VELLUM	This item appears only when CONFIGURE FUSER MODE MENU=YES. Most paper types are set to NORMAL by default. The exceptions are as follows: ROUGH=HIGH VELLUM=VELLUM For a complete list of supported paper types, see page A-6.

Print Quality Menu

Some items in this menu can be accessed from a software application, or from the printer driver (if the appropriate driver is installed). Printer driver and software application settings override control panel settings. For more information, see page 56.

Print Quality Menu

Item	Values	Explanation
RESOLUTION= FASTRES 1200	300 600 FASTRES 1200 PRORES 1200	<p>Select the resolution from the following values:</p> <p>300: Produces draft print quality at the printer's maximum speed (16 ppm). 300 dpi (dots per inch) is recommended for some bitmapped fonts and graphics, and for compatibility with the HP LaserJet III family of printers.</p> <p>600: Produces high print quality at the printer's maximum speed (16 ppm).</p> <p>FASTRES 1200: Produces optimum print quality (comparable to 1200 dpi) at the printer's maximum speed (16 ppm).</p> <p>PRORES 1200: Produces optimum print quality (true 1200 dpi) at half the printer's maximum speed (8 ppm).</p> <p>When the resolution is changed, any downloaded resources (such as fonts or macros) will need to be downloaded again, unless they are stored on an optional hard disk or flash DIMM.</p> <p>Note It is best to change the resolution from the printer driver or software application. (Driver and software settings override control panel settings.)</p>
RET=MEDIUM	OFF LIGHT MEDIUM DARK	<p>Use the printer's Resolution Enhancement technology (REt) setting to produce print with smooth angles, curves, and edges.</p> <p>REt does not affect print quality when the print resolution is set to ProRes 1200. All other print resolutions, including FastRes 1200, benefit from REt.</p> <p>Note It is best to change the REt setting from the printer driver or software application. (Driver and software settings override control panel settings.)</p>

Print Quality Menu (Continued)

Item	Values	Explanation
ECONOMODE=OFF	OFF ON	<p>Turn EconoMode on (to save toner) or off (for high quality).</p> <p>EconoMode creates draft-quality printing by reducing the amount of toner on the printed page by up to 50%.</p> <p>Caution HP does not recommend full-time use of EconoMode. (If EconoMode is used full-time, it is possible that the toner supply will outlast the mechanical parts in the toner cartridge.)</p> <p>Note It is best to turn EconoMode on or off from the printer driver or software application. (Driver and software settings override control panel settings.)</p>
TONER DENSITY=3	1 2 3 4 5	<p>Lighten or darken the print on the page by changing the toner density setting. The settings range from 1 (light) to 5 (dark), but the default setting of 3 usually produces the best results. Use a lower toner density setting to save toner.</p> <p>Note It is best to change the toner density from the printer driver or software application. (Driver and software settings override control panel settings.)</p>
CREATE CLEANING PAGE	No value to select.	<p>Press [Select] to print a cleaning page (for cleaning excess toner from the paper path).</p> <p>In order for the cleaning page to work properly, print the page on copier grade paper (not bond or rough paper). Follow the instructions on the cleaning page.</p> <p>For more information, see page 69.</p>
PROCESS CLEANING PAGE	No value to select.	<p>This item appears only after a cleaning page has been generated (as described above).</p> <p>Press [Select] to process the cleaning page.</p>

Printing Menu

Some items in this menu can be accessed from a software application, or from the printer driver (if the appropriate driver is installed). Printer driver and software application settings override control panel settings. For more information, see page 56.

Printing Menu

Item	Values	Explanation
COPIES=1	1 to 999	<p>Set the default number of copies by selecting any number from 1 to 999. Press [-Value+] once to change the setting by increments of 1, or hold down [-Value+] to scroll by increments of 10.</p> <p>Note It is best to set the number of copies from the printer driver or software application. (Driver and software settings override control panel settings.)</p>
PAPER= LETTER (110V printers) and ENVELOPE= COM10 (110V printers)	For supported paper sizes, see page A-3.	<p>Set the default image size for paper and envelopes. (The item name will change from paper to envelope as you scroll through the available sizes.)</p> <p>Note The defaults indicated here are for 110V printers. The default paper size for 220V printers is A4. The default envelope size for 220V printers is DL.</p>
CONFIGURE CUSTOM PAPER=NO	NO YES	<p>NO: The custom paper menu items are not accessible.</p> <p>YES: The custom paper menu items appear (see below).</p>
UNIT OF MEASURE= INCHES (110V printers) or MILLIMETERS (220V printers)	INCHES MILLIMETERS	<p>This item appears only when CONFIGURE CUSTOM PAPER=YES. Select the unit of measurement for the custom paper size.</p>

Printing Menu (Continued)

Item	Values	Explanation
X DIMENSION= 12.28 INCHES (110V printers) or 312 MILLIMETERS (220V printers)	3.00 to 12.28 INCHES (110V printers) or 76 to 312 MILLIMETERS (220V printers)	This item appears only when CONFIGURE CUSTOM PAPER=YES. Select the dimension to be fed into the printer.
Y DIMENSION= 18.50 INCHES (110V printers) or 470 MILLIMETERS (220V printers)	5.00 to 18.50 INCHES (110V printers) or 127 to 470 MILLIMETERS (220V printers)	This item appears only when CONFIGURE CUSTOM PAPER=YES. Select the other dimension.
ORIENTATION= PORTRAIT	PORTRAIT LANDSCAPE	Determine the default orientation of print on the page. Note It is best to set the page orientation from the printer driver or software application. (Driver and software settings override control panel settings.)
FORM=60 LINES (110V printers) or 64 LINES (220V printers)	5 to 128	Sets vertical spacing from 5 to 128 lines for default paper size. Press [-Value+] once to change the setting by increments of 1, or hold down [-Value+] to scroll by increments of 10.
PCL FONT SOURCE= INTERNAL	INTERNAL SOFT SLOT 1, 2, or 3	INTERNAL: Internal fonts. SOFT: Permanent soft fonts. SLOT 1, 2, or 3: Fonts stored in one of the three DIMM slots.
PCL FONT NUMBER= 0	0 to 999	The printer assigns a number to each font and lists them on the PCL Font List (page 103). The font number appears in the Font # column of the printout.
PCL FONT PITCH= 10.00	0.44 to 99.99	This item might not appear, depending on the font selected. Press [-Value+] once to change setting by increments of .01 for pitch, or hold down [-Value+] to scroll by increments of 1.

Printing Menu (Continued)

Item	Values	Explanation
PCL FONT POINT SIZE=12.00	4.00 to 999.75	This item might not appear, depending on the font selected. Press [-Value+] once to change setting by increments of .25 for point size, or hold down [-Value+] to scroll by increments of 1.
PCL SYMBOL SET= PC-8	PC-8 many others	Select any one of several available symbol sets from the printer's control panel. A symbol set is a unique grouping of all the characters in a font. PC-8 or PC-850 is recommended for line draw characters. Order the <i>PCL 5/PJL Technical Reference Documentation Package</i> for symbol set charts or for more information (page 10).
COURIER=REGULAR	REGULAR DARK	Select the version of Courier font to use: REGULAR: The internal Courier font available on the HP LaserJet 4 series printers. DARK: The internal Courier font available on the HP LaserJet III series printers. Both fonts are not available at the same time.
WIDE A4=NO	NO YES	The Wide A4 setting changes the number of characters that can be printed on a single line of A4 paper. NO: Up to 78 10-pitch characters can be printed on one line. YES: Up to 80 10-pitch characters can be printed on one line.
APPEND CR TO LF= NO	NO YES	Select YES to append a carriage return to each line feed encountered in backward-compatible PCL jobs (pure text, no job control). Some environments, such as UNIX, indicate a new line using only the line feed control code. This option allows the user to append the required carriage return to each line feed.
PRINT PS ERRORS= OFF	OFF ON	Select ON to print the PS error page when PS errors occur.

Configuration Menu

Items in this menu affect the printer's behavior. Configure the printer according to your printing needs.

Configuration Menu

Item	Values	Explanation
POWERSAVE= 30 MINUTES	OFF 15 MINUTES 30 MINUTES 1 HOUR 2 HOURS 3 HOURS	<p>Set the printer to enter PowerSave after it has been idle for a specified amount of time. Turning PowerSave off is not recommended. The PowerSave feature does the following:</p> <ul style="list-style-type: none">• Minimizes the amount of power consumed by the printer when it is idle.• Reduces wear on the printer's electronic components. (Turns off the display's backlight.) <p>When you send a print job, press a control panel key, open a paper tray, or open the top cover, the printer automatically comes out of PowerSave mode.</p> <p>Note PowerSave turns off the backlight on the display, but the display is still readable.</p>
PERSONALITY= AUTO	AUTO PCL PS	<p>Select the default printer language (personality). Possible values are determined by which valid languages are installed in the printer.</p> <p>Normally you should not change the printer language (the default is <code>AUTO</code>). If you change it to a specific printer language, the printer will not automatically switch from one language to another unless specific software commands are sent to the printer.</p>

Configuration Menu (Continued)

Item	Values	Explanation
RESOURCE SAVE= OFF	OFF ON AUTO	<p>Dedicate printer memory to save each language's permanent resources. (You might need to add memory to the printer in order for this item to appear.) The amount of memory set aside can be different for each installed language. Some languages might have memory set aside for resource saving without requiring all languages to do so. Any time the amount of memory dedicated to a specific language is changed, all languages will lose all saved resources, including any unprocessed print jobs.</p> <p>OFF: No language resource saving is performed, and language-dependent resources, such as fonts and macros, are lost when language or resolution changes.</p> <p>ON: An item will appear for each installed language that allows the user to allocate a particular amount of memory to that language's resource saving area. (See the items below.)</p> <p>AUTO: The printer automatically determines the amount of memory to use for each installed language's resource saving area.</p> <p>For more information, see page C-6.</p>
PCL MEMORY= 400K	0K and up (This value depends on the amount of installed memory.)	<p>This item appears only when RESOURCE SAVE=ON. Select the amount of memory used for saving PCL resources. Printer default is the minimum amount of memory needed to perform resource saving for PCL. Press [-Value+] to change settings by increments of 10 (up to 100 KB) or by increments of 100 (above 100 KB).</p> <p>For more information, see page C-6.</p>
PS MEMORY= 400K	0K and up (This value depends on the amount of installed memory.)	<p>This item appears only when RESOURCE SAVE=ON. Select the amount of memory used for saving PS resources. Printer default is the minimum amount of memory needed to perform resource saving for PS. Press [-Value+] to change settings by increments of 10 (up to 100 KB) or by increments of 100 (above 100 KB).</p> <p>For more information, see page C-6.</p>

Configuration Menu (Continued)

Item	Values	Explanation
PAGE PROTECT= AUTO	AUTO ON	<p>This item appears only after a 21 PAGE TOO COMPLEX; PRESS GO TO CONTINUE message displays (page 84).</p> <p>Memory Enhancement technology (MEt) attempts to guarantee that all pages will print. If the page does not print, turn PAGE PROTECT to ON. This might increase chances of a 20 INSUFFICIENT MEMORY; PRESS GO TO CONTINUE message. If this occurs, simplify the print job or install additional memory (page C-1).</p>
CLEARABLE WARNINGS=JOB	JOB ON	<p>Set the amount of time that a clearable warning is displayed on the printer's control panel.</p> <p>JOB: Warning messages display on the control panel until the end of the job from which they were generated.</p> <p>ON: Warning messages display on the control panel until [Go] is pressed.</p>
AUTO CONTINUE= ON	ON OFF	<p>Determine how the printer reacts to errors.</p> <p>ON: If an error occurs that prevents printing, the message will display, and the printer will go offline for 10 seconds before returning online.</p> <p>OFF: If an error occurs that prevents printing, the message will remain on the display and the printer will remain offline until [Go] is pressed.</p> <p>If the printer is on a network, you will probably want to turn AUTO CONTINUE to ON.</p>
TONER LOW= CONTINUE	CONTINUE STOP	<p>Determine how the printer behaves when toner is low. The TONER LOW message will first appear when the toner cartridge is almost out of toner. (About 100 to 300 sheets can still be printed.)</p> <p>CONTINUE: The printer will continue to print while the TONER LOW message is displayed.</p> <p>STOP: The printer will go offline and wait for further action.</p> <p>For more information, see page 64.</p>

Configuration Menu (Continued)

Item	Values	Explanation
MOPIER MODE= STANDARD	STANDARD ENHANCED OFF	<p>Determine how the mopier functions behave. This item appears only when there is at least 8 MB of memory or an optional hard disk is installed.</p> <p>STANDARD: This option is available if there is either a hard disk installed or a RAM disk configured in memory. This option uses I/O data stored in printer memory for generating multiple original prints. (All copies will print at the same speed as the first copy.)</p> <p>ENHANCED: This option is available if there is a hard disk installed and at least 8 MB of memory. This option uses engine video data for printing multiple original prints and should print all copies after the first at the printer's maximum speed.</p> <p>OFF: Disables the mopier functions. (The printer will not spool any jobs to the hard disk.)</p> <p>When the mopier mode is changed, any downloaded resources (such as fonts or macros) will need to be downloaded again, unless they are stored on an optional hard disk or flash DIMM.</p>
RAM DISK=OFF	OFF ON AUTO	<p>Determine how the RAM disk is configured. This item appears only if there is no optional hard disk installed and the printer has at least 8 MB of memory.</p> <p>OFF: The RAM disk is disabled.</p> <p>ON: The RAM disk is enabled. Configure the amount of memory to be used through the following item: RAM DISK SIZE.</p> <p>Note If the setting is changed from OFF to ON or from OFF to AUTO, the printer will automatically reinitialize when it becomes idle.</p>
RAM DISK SIZE= xxxxK	0K and up (This value depends on the amount of installed memory.)	<p>Determine the size of the RAM disk. This item appears if RAM DISK=ON or AUTO.</p> <p>Press [-Value+] to change settings by increments of 100.</p> <p>Note This setting cannot be changed if RAM DISK=AUTO. Changing this value will cause the printer to reinitialize when it becomes idle.</p>

Configuration Menu (Continued)

Item	Values	Explanation
JAM RECOVERY= AUTO	AUTO ON OFF	Determine how the printer behaves when a paper jam occurs. AUTO: The printer automatically selects the best mode for printer jam recovery (usually ON). This is the default setting. ON: The printer automatically reprints pages after a paper jam is cleared. OFF: The printer does not reprint pages following a paper jam. Printing performance might be increased with this setting.
PAPER REFORMING= OFF	OFF ON	Paper reforming has two main purposes: <ol style="list-style-type: none">1. To reduce jams, wrinkles, and bent corners when printing on both sides of a sheet of paper (duplexing).2. To reduce bent corners and wrinkles when printing on one side of a sheet of narrow media (such as legal, rotated letter, or rotated A4). Print speed will be slower when PAPER REFORMING=ON.
MAINTENANCE MESSAGE=OFF	OFF	This item appears only after the PERFORM PRINTER MAINTENANCE message displays. OFF: The PERFORM PRINTER MAINTENANCE message will be cleared and will not be displayed again until the next maintenance is due. The message should not be turned off unless the printer maintenance has been performed. If the required maintenance is not performed, the printer's performance will degrade.
SMALL PAPER SPEED=NORMAL	NORMAL SLOW	Select SLOW when alternately printing envelopes or small paper and standard paper sizes. Be sure to return the speed to NORMAL when finished.

I/O Menu

Items in the I/O (input/output) Menu affect the communication between the printer and the computer.

I/O Menu

Item	Values	Explanation
I/O TIMEOUT=15	5 to 300	<p>Select the I/O timeout period in seconds. (I/O timeout refers to the time, measured in seconds, that the printer waits before ending a print job.)</p> <p>This setting allows you to adjust timeout for best performance. If data from other ports appear in the middle of your print job, increase the timeout value.</p> <p>Press [- Value +] once to change settings by increments of 1, or hold down [- Value +] to scroll by increments of 10.</p>
I/O BUFFER=AUTO	AUTO ON OFF	<p>Allocate memory for I/O buffering.</p> <p>AUTO: The printer automatically reserves memory for I/O buffering. Additional configurations are not required and the I/O BUFFER SIZE menu item does not appear.</p> <p>ON: The I/O BUFFER SIZE item appears (see below). Specify the amount of memory to be used for I/O buffering.</p> <p>OFF: I/O buffering is not performed and the I/O BUFFER SIZE item does not appear.</p> <p>When the I/O buffer setting is changed, any downloaded resources (such as fonts or macros) will need to be downloaded again, unless they are stored on an optional hard disk or flash DIMM.</p> <p>For more information, see page C-7.</p>
I/O BUFFER SIZE=100K	10K and up	<p>This item appears only when I/O BUFFER=ON. Specify the amount of memory for I/O buffering. The maximum amount of memory available for I/O buffering is determined by the amount of memory installed in the printer, the languages installed in the printer, and by other memory allocations that must be made.</p> <p>Press [-Value +] to change settings by increments of 10 (up to 100 KB) or by increments of 100 (above 100 KB).</p>

I/O Menu (Continued)

Item	Values	Explanation
PARALLEL HIGH SPEED=YES	YES NO	Select the speed at which data is transmitted to the printer. YES: The printer accepts faster parallel communications used for connections with newer computers. NO: The printer accepts slower parallel communications used for connections with older computers.
PARALLEL ADV FUNCTIONS=ON	ON OFF	Turn the bidirectional parallel communication on or off. The default is set for a bidirectional parallel port (IEEE-1284). This setting allows the printer to send status readback messages to the computer. (Turning the parallel advanced functions on might slow language switching.)
SERIAL PACING= DTR/DSR	DTR/DSR XON/XOFF	Select the type of pacing used. Pacing, or "handshaking" allows the printer to tell the computer when to send information. The printer uses XON/XOFF and DTR/DSR signal protocols rather than ETX/ACK protocol. DTR/DSR: Select this value if your computer requires hardware flow control (most personal computers do). XON/XOFF: Select this value if your computer requires software flow control (a UNIX workstation, for example). The SERIAL ROBUST XON item appears (see below).
SERIAL ROBUST XON=ON	ON OFF	This item appears only when SERIAL PACING=XON/XOFF. Select the method for generating XONs. ON: The printer sends an XON when the printer is online and when sufficient buffer space is available. If the host does not receive data within approximately one second, the printer will transmit additional XONs at one second intervals until the host receives data. OFF: The printer sends one XON when it can accept more data or when it is online. The printer does not send XONs every second while the printer is online and ready for more data.

I/O Menu (Continued)

Item	Values	Explanation
SERIAL BAUD RATE=9600	300 600 1200 2400 4800 9600 19200 38400 57600 115200	Select the printer's baud rate (speed at which information is transferred) for communicating from the computer to the printer.
SERIAL DTR POLARITY=HIGH	HIGH LOW	Determine whether pin #8 is high or low when the printer is ready. HIGH: Pin #8 is held high when the printer is ready. LOW: Pin #8 is held low when the printer is ready.

EIO Menu (5000 N/5000 GN)

EIO (enhanced input/output) Menus depend on the particular accessory product installed in an EIO slot of the printer. If the printer contains an HP JetDirect print server EIO card, you can configure basic networking parameters using the EIO Menu. These and other parameters can also be configured through HP JetAdmin.

EIO Menu

Item	Values	Explanation
CFG NETWORK=NO	NO YES	NO: The JetDirect Menu is not accessible. YES: The JetDirect Menu appears.
NOVELL=ON	ON OFF	Select whether the IPX/SPX protocol stack (in Novell NetWare networks, for example) is enabled (on) or disabled (off).
DLC/LLC=ON	ON OFF	Select whether the DLC/LLC protocol stack is enabled (on) or disabled (off).
TCP/IP=ON	ON OFF	Select whether the TCP/IP protocol stack is enabled (on) or disabled (off).
ETALK=ON	ON OFF	Select whether the Apple EtherTalk protocol stack is enabled (on) or disabled (off).
CFG NOVELL=NO	NO YES	NO: The IPX/SPX Menu is not accessible. YES: The IPX/SPX Menu appears. In the IPX/SPX Menu, you can specify the frame type parameter used on your network. The default is AUTO, to automatically set and limit the frame type to the one detected. For Ethernet cards, frame type selections include EN_8023, EN_II, EN_8022, EN_SNAP. For Token Ring cards, frame type selections include TR_8022, TR_SNAP. In the IPX/SPX Menu for Token Ring cards, you can also specify NetWare Source Routing parameters, which include SRC_RT=AUTO (default), OFF, SINGLE R, or ALL RT.

EIO Menu (Continued)

Item	Values	Explanation
CFG TCP/IP=NO	NO YES	<p>NO: The TCP/IP Menu is not accessible.</p> <p>YES: The TCP/IP Menu appears. In the TCP/IP Menu, you can specify <code>BOOTP=YES</code> for TCP/IP parameters to be automatically loaded from a bootp or DHCP server when the printer is turned on. If you specify <code>BOOTP=NO</code>, you can manually set selected TCP/IP parameters from the control panel. You can manually set each byte of the IP address (IP), Subnet Mask (SM), Syslog Server (LG), and Default Gateway (GW). Also, you can manually set the Timeout time period.</p> <p>Note</p> <p>If no IP address is assigned within the first 5 minutes, the HP JetDirect print server card will assume a default IP address of 192.0.0.192.</p>
CFG ETALK=NO	NO YES	<p>NO: The EtherTalk Menu is not accessible.</p> <p>YES: The EtherTalk Menu appears. In the EtherTalk Menu you can set the AppleTalk phase parameter (<code>ETALK PHASE=1</code> or <code>2</code>) for your network.</p>

Resets Menu

Use this menu with caution. You can lose buffered page data or printer configuration settings when you select these items. Only reset the printer under the following circumstances:

- You want to restore the printer's default settings.
- Communication between the printer and computer has been interrupted.
- You are using both the serial and parallel I/O ports, and one of the ports is having problems.

The items in the Resets Menu will clear all memory in the printer, while **[Cancel Job]** clears only the current job.

Resets Menu

Item	Explanation
RESET MEMORY	This item clears the printer buffer and the active I/O input buffer, and makes the control panel defaults current. The DATA RECEIVED message might display on the control panel. Resetting memory during a print job can result in data loss.
RESTORE FACTORY SETTINGS	This item performs a simple reset and restores most of the factory (default) settings. This item also clears the input buffer for the active I/O. The DATA RECEIVED message might display on the printer's control panel.
RESET ACTIVE I/O CHANNEL	This item performs a simple reset and clears the input and output buffers (for the active I/Os only). The DATA RECEIVED message might display on the printer's control panel.
RESET ALL I/O CHANNELS	This item performs a simple reset and clears the input and output buffers for all I/Os.

Printer Memory and Expansion

Overview

The printer has three dual in-line memory module (DIMM) slots for upgrading with:

- More printer memory. DIMMs are available in 4, 8, 16, and 32 MB, for a maximum of 100 MB.
- Flash memory DIMMs, available in 2 and 4 MB. Unlike standard printer memory, flash DIMMs can be used to permanently store downloaded items in the printer, even when the printer is off.
- DIMM-based accessory fonts, macros, and patterns.
- Other DIMM-based printer languages and printer options.

Note

Single in-line memory modules (SIMMs) used on previous HP LaserJet printers are not compatible with the printer.

You might want to add more memory to the printer if you often print complex graphics or PS documents, print with the optional duplexer, use many downloaded fonts, print at ProRes 1200, or print large paper sizes (such as A3, B4, or 11 x 17).

The printer has two enhanced input/output (EIO) slots for expanding the printer's capabilities with:

- A network card.
- A mass storage device, such as a hard disk.

For ordering information, see page 9.

To find out how much memory is installed in the printer, or to find out what is installed in the EIO slots, print a configuration page (page 101).

Installing Memory

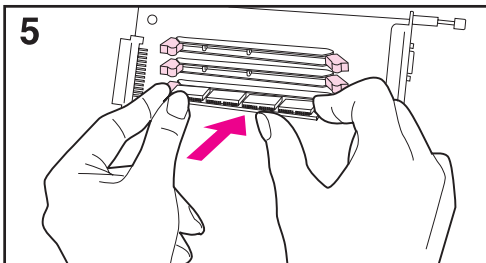
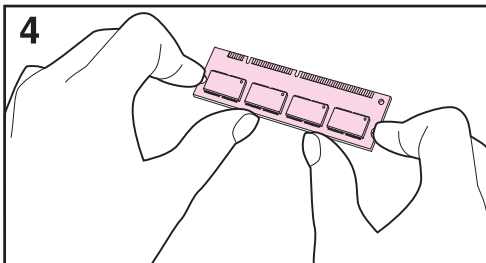
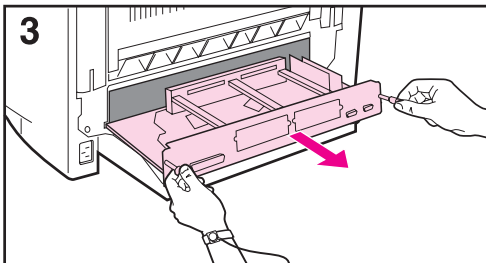
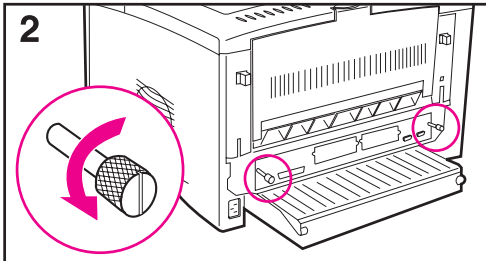
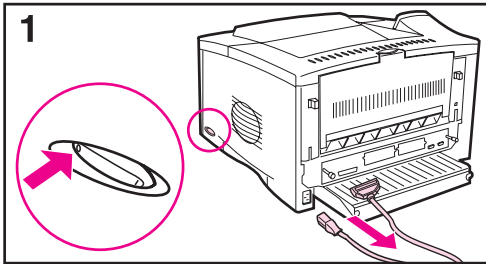

Caution

Static electricity can damage dual in-line memory modules (DIMMs). When handling DIMMs, either wear an antistatic wrist strap or frequently touch the surface of the DIMM's antistatic package, then touch bare metal on the printer.

If you have not already done so, print a configuration page to find out how much memory is installed in the printer before adding more memory (page 101).

- 1 Turn the printer off. Unplug the power cord and disconnect any cables. (If an optional duplexer is installed, you will need to remove the rear section and the cable tray first. Go to page C-4.)
- 2 Loosen the two captive thumb screws on the back of the printer.
- 3 Grasp the screws and pull the formatter board out of the printer. Place it on a flat, non-conductive surface.
- 4 Remove the DIMM from the antistatic package. Hold the DIMM with fingers against the side edges and thumbs against the back edge. Align the notches on the DIMM with the DIMM slot. (Check that the locks on each side of the DIMM slot are open, or outward.)
- 5 Press the DIMM straight into the slot (press firmly). Make sure the locks on each side of the DIMM snap inward into place. (To remove a DIMM, the locks must be released.)

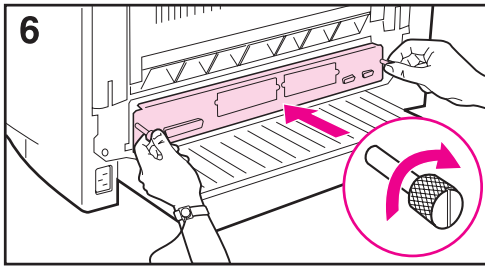

6 Slide the formatter board back into the printer and tighten the two screws.

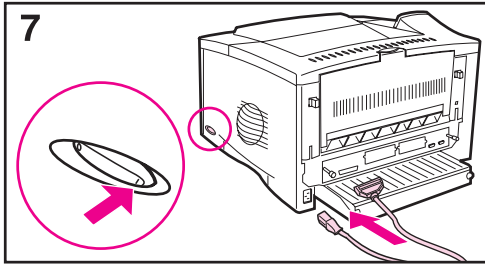

7 If an optional duplexer is installed, reattach the cable tray and the rear section of the duplexer. Reattach any interface cables, and the power cord. Turn the printer on and test the DIMM. (Go to page C-5.)

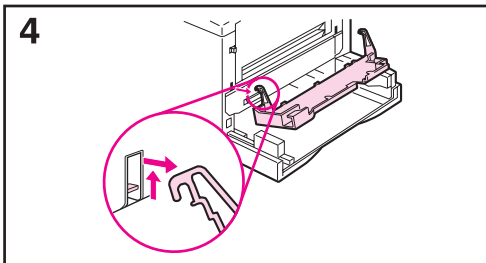
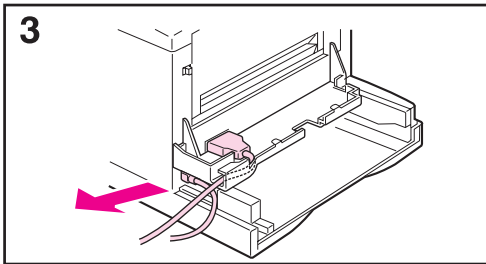
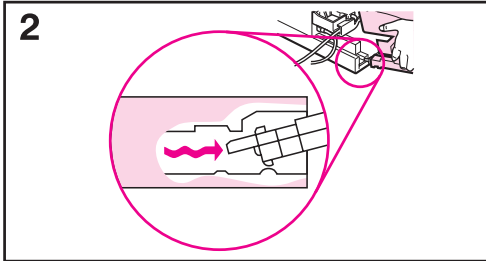
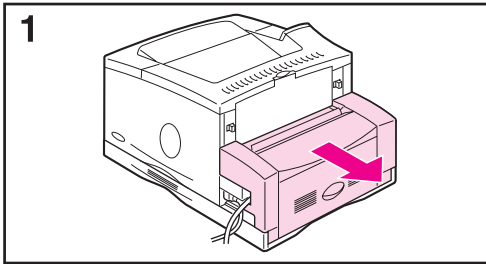

If an optional duplexer is installed:

- 1** Slide the rear section of the duplexer away from the printer.
- 2** Remove the rear section of the duplexer by lifting and rotating the rear section to clear all of the tabs in the grooves, as illustrated.
- 3** Unplug the power cord and disconnect any cables.
- 4** Remove the cable tray by lifting it out of position, as illustrated.

Go back to Step 2, on page C-2.

Note

Reverse these steps to install the cable tray and the rear section of the duplexer. Make sure the cable tray is properly installed and the cables are routed through the left side.

Checking Memory Installation

Follow this procedure to verify that DIMMs are installed correctly:

- 1 Check that the printer's control panel displays **READY** when the printer is turned on. If an error message appears, a DIMM might have been incorrectly installed. Check the printer messages (page 79).
- 2 Print a new configuration page (page 101).
- 3 Check the memory section on the configuration page and compare it to the configuration page printed before the DIMM installation. If the amount of memory has not increased, the DIMM might not be installed correctly (repeat the installation procedure) or the DIMM might be defective (try a new DIMM).

Note

If you installed a printer language (personality), check the Installed Personalities and Options section on the configuration page. This area should list the new printer language.

Adjusting Memory Settings

Resource Saving

Resource Saving allows the printer to keep downloaded resources (permanent downloaded fonts, macros, or patterns) in memory when the printer language or resolution is changed.

If you do not have an optional hard disk or flash DIMM for storing downloaded resources, you might want to change the amount of memory allocated to each language when downloading an unusually large number of fonts, or if the printer is in a shared environment.

The minimum amount of memory that can be allocated to Resource Saving is 400 KB each for PCL and PS.

To determine how much memory to allocate to a language:

- 1 From the Configuration Menu, set `RESOURCE SAVE=ON` (page B-11). You might need to add memory to the printer in order for this option to appear in the printer's control panel.
- 2 Also from the Configuration Menu, choose either `PCL MEMORY` or `PS MEMORY` and change the setting to the highest value displayed. This amount will vary depending upon how much memory is installed in the printer.
- 3 Using a software application, download all the fonts you want to use in the selected language.
- 4 Print a configuration page (page 101). The amount of memory used by the fonts is listed next to the language. Round this figure up to the nearest 100 KB. (For example, if 475 KB are shown, 500 KB should be reserved.)
- 5 From the Configuration Menu, set `PCL MEMORY` or `PS MEMORY` to the value determined in step 4.
- 6 Repeat step 3. (You must download all fonts again. See the note below.)

Note

When you change the Resource Saving setting, all downloaded resources (such as fonts or macros) will need to be downloaded again, unless they are stored on an optional hard disk or flash DIMM.

I/O Buffering

To allow the computer to continue working without waiting for the print job to finish queuing, the printer uses a portion of its memory (an I/O buffer) to hold jobs in progress. (If I/O buffering is off, no memory is reserved for this function.)

In most cases, it is best to let the printer automatically reserve memory for I/O buffering. (For each megabyte of memory added to the printer, 100 kilobytes are reserved.)

To speed network printing, you might want to increase the amount of memory reserved for I/O buffering.

To change the I/O Buffer setting:

- 1 From the I/O Menu, set `I/O BUFFER=ON` (page B-15).
- 2 Also from the I/O Menu, set `I/O SIZE` to the desired value.

Note

When you change the I/O Buffer setting, all downloaded resources (such as fonts or macros) will need to be downloaded again, unless they are stored on an optional hard disk or flash DIMM.

Installing EIO Cards/Mass Storage

Turn off the printer before installing the EIO card or mass storage device.

See Figure C-1 for orientation and location of the EIO card or optional mass storage device, such as a hard disk.

Use HP JetAdmin to delete files from a mass storage device. Use HP FontSmart to manage fonts on a mass storage device. For more information, see the printer software help.

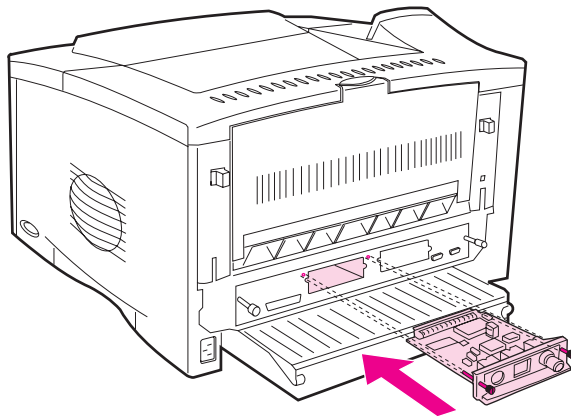

Figure C-1 Installing EIO Cards or Mass Storage Devices

Printer Commands

Overview

Most software applications do not require you to enter printer commands. See your computer and software documentation to find the method for entering printer commands, if needed.

PCL PCL printer commands tell the printer which tasks to perform or which fonts to use. This appendix provides a quick reference for users who are already familiar with PCL command structure.

- The PCL 5e printer commands are backward-compatible with previous versions of PCL.
- The PCL 6 printer commands take full advantage of the printer's features.

HP-GL/2 The printer has the ability to print vector graphics using the HP-GL/2 graphics language. Printing in the HP-GL/2 language requires that the printer leave PCL language and enter HP-GL/2 mode, which can be done by sending the printer PCL code. Some software applications switch languages through their drivers.

PJL HP's Printer Job Language (PJL) provides control above PCL and other printer languages. The four major functions provided by PJL are: printer language switching, job separation, printer configuration, and status readback from the printer. PJL commands may be used to change printer default settings.

Note The table at the end of this appendix contains commonly used PCL 5e commands (page D-5). For a complete listing and explanation of how to use PCL, HP-GL/2, and PJL commands, order the *PCL 5/PJL Technical Reference Documentation Package* (page 10).

To receive more information about printer commands via fax, call HP FIRST (Fax Information Retrieval Service Technology) and request an index for HP LaserJet printers. (See the HP Support pages at the front of this user's guide.)

Understanding PCL Printer Command Syntax

Before using printer commands, compare these characters:

Lowercase l:	<i>l</i>	Uppercase O:	O
Number one:	1	Number 0:	Ø

Many printer commands use the lowercase letter l (*l*) and the number one (1), or the uppercase letter O (O) and the number zero (Ø). These characters may not appear on your screen as shown here. You must use the exact character and case specified for PCL printer commands.

Figure D-1 displays the elements of a typical printer command (in this instance, a command for page orientation).

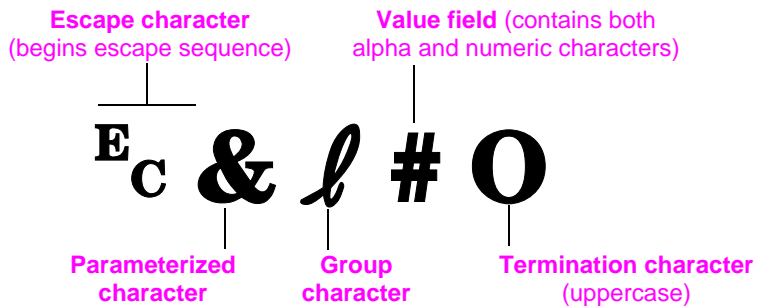

Figure D-1 Printer Command Elements

Combining Escape Sequences

Escape sequences may be combined into one escape sequence string. There are three important rules to follow when combining code:

- 1 The first two characters after the E_c character (the parameterized and group characters, see Figure D-1) must be the same in all of the commands to be combined.
- 2 When combining escape sequences, change the uppercase (termination) character in each individual escape sequence to lower case.
- 3 The final character of the combined escape sequence must be uppercase.

The following is an example of an escape sequence string that would be sent to the printer to select legal paper, landscape orientation, and 8 lines per inch:

```
 $\text{E}_c\&l3A\text{E}_c\&l1O\text{E}_c\&l8D$ 
```

The following escape sequence sends the same printer commands by combining them into a shorter sequence:

```
 $\text{E}_c\&l3a1o8D$ 
```

Entering Escape Characters

Printer commands always begin with the escape character (E_c).

The following table shows how the escape character can be entered from various DOS software applications.

DOS Software Application	Entry	What Appears
Lotus 1-2-3 and Symphony	Type $\backslash027$	027
Microsoft Word for DOS	Hold down Alt and type $\backslash027$ on the numeric keypad	←
WordPerfect for DOS	Type $<27>$	$<27>$
MS-DOS Edit	Hold down Ctrl-P, and press Esc	←
MS-DOS Edlin	Hold down Ctrl-V, and press [^[
dBase	?? CHR(27)+"command"	?? CHR(27)+" "

Selecting PCL Fonts

PCL printer commands for selecting fonts can be found on the PCL Font List (page 103). A sample section is shown below. Notice the two variable boxes for symbol set and point size.

Univers Medium Scale <esc>(<esc>(s1p v0s0b4148T I 01

These variables must be filled in or the printer will use defaults. For example, if you want a symbol set that contains line-draw characters, select the 10U (PC-8) or 12U (PC-850) symbol set. Other common symbol set codes are listed in the table on page D-7.

Note

Fonts are either “fixed” or “proportional” in spacing. The printer contains both fixed fonts (Courier, Letter Gothic, and Lineprinter) and proportional fonts (CG Times, Arial®, Times New Roman®, and others).

Fixed-spaced fonts are generally used in applications such as spreadsheets and databases, where it is important for columns to line up vertically. Proportional-spaced fonts are generally used in text and word processing applications.

Common PCL Printer Commands

Common PCL Printer Commands

	Function	Command	Options (#)
Job Control Commands	Reset	E _C E	n/a
	Number of Copies	E _C &l#X	1 to 999
	2-sided/1-sided printing	E _C &l#S	0 = Simplex (1-sided) printing 1 = Duplex (2-sided) with long edge binding 2 = Duplex (2-sided) with short edge binding
Page Control Commands	Paper Source	E _C &l#H	0 = prints or ejects current page 1 = Tray 2 2 = manual feed, paper 3 = manual feed, envelope 4 = Tray 1 5 = Tray 3 7 = auto select 8 = Tray 4 20-69 = external trays
	Paper size	E _C &l#A	1 = Executive 2 = Letter 3 = Legal 25 = A5 6 = 11 x 17 24 = A6 26 = A4 27 = A3 44 = B6-JIS 45 = B5-JIS 46 = B4-JIS 71 = Postcard (single) 72 = Postcard (double) 80 = Monarch 81 = Commercial 10 90 = DL 91 = International C5 100 = B5 101 = Custom
	Paper Type	E _C &n#	5WdBond = Bond 6WdPlain = Plain 6WdColor = Color 7WdLabels = Labels 9WdRecycled = Recycled 11WdLetterhead = Letterhead 10WdCardstock = Cardstock 11WdPrepunched = Prepunched 11WdPreprinted = Preprinted 13WdTransparency = Transparency #WdCustompapertype = Custom ¹
	Orientation	E _C &l#O	0 = Portrait 1 = Landscape 2 = Reverse Portrait 3 = Reverse Landscape

Common PCL Printer Commands (Continued)

	Function	Command	Options (#)
Page Control Commands (Continued)	Top Margin	$E_C \& l \# E$	# = number of lines
	Text Length (bottom margin)	$E_C \& l \# F$	# = number of lines from top margin
	Left Margin	$E_C \& a \# L$	# = column number
	Right Margin	$E_C \& a \# M$	# = column number from left margin
	Horizontal Motion Index	$E_C \& k \# H$	1/120-inch increments (compresses print horizontally)
	Vertical Motion Index	$E_C \& l \# C$	1/48-inch increments (compresses print vertically)
	Line Spacing	$E_C \& l \# D$	# = lines per inch (1, 2, 3, 4, 5, 6, 12, 16, 24, 48)
	Perforation Skip	$E_C \& l \# L$	0 = disable 1 = enable
Cursor Positioning	Vertical Position (Rows)	$E_C \& a \# R$	# = row number
	Vertical Position (Dots)	$E_C \# p \# Y$	# = dot number (300 dots = 1 inch)
	Vertical Position (Decipoints)	$E_C \& a \# V$	# = decipoint number (720 decipoints = 1 inch)
	Horizontal Position (Columns)	$E_C \& a \# C$	# = column number
	Horizontal Position (Dots)	$E_C \# p \# X$	# = dot number (300 dots = 1 inch)
	Horizontal Position (Decipoints)	$E_C \& a \# H$	# = decipoint number (720 decipoints = 1 inch)
Programming Hints	End of Line Wrap	$E_C \& s \# C$	0 = Enable 1 = Disable
	Display Functions On	$E_C Y$	n/a
	Display Functions Off	$E_C Z$	n/a
Language Selection	Enter PCL Mode	$E_C \% \# A$	0 = Use previous PCL cursor position 1 = Use current HP-GL/2 pen position
	Enter HP-GL/2 Mode	$E_C \% \# B$	0 = Use previous HP-GL/2 pen position 1 = Use current PCL cursor position

Common PCL Printer Commands (Continued)

Function	Command	Options (#)
Symbol Sets ²	E _C (#	8U = HP Roman-8 Symbol Set 10U = IBM Layout (PC-8) (code page 437) Default Symbol Set 12U = IBM Layout for Europe (PC-850) (code page 850) 8M = Math-8 19U = Windows 3.1 Latin 1 9E = Windows 3.1 Latin 2 (commonly used in Eastern Europe) 5T = Windows 3.1 Latin 5 (commonly used in Turkey) 579L = Wingdings Font
Primary Spacing	E _C (s#P	0 = fixed 1 = proportional
Primary Pitch	E _C (s#H	# = characters/inch
Set Pitch Mode ³	E _C &k#S	0 = 10 4 = 12 (elite) 2 = 16.5 - 16.7 (compressed)
Primary Height	E _C (s#V	# = points
Primary Style ²	E _C (s#S	0 = upright (solid) 1 = italic 4 = condensed 5 = condensed italic
Primary Stroke Wt. ²	E _C (s#B	0 = medium (book or text) 1 = semi bold 3 = bold 4 = extra bold
Typeface ²	E _C (s#T	Print a PCL font list to view the command for each internal font (page 103).

¹For custom paper, replace "Custompapertype" with the name of the paper, and replace the "#" with the number of characters in the name, plus 1.

²Order the *PCL 5/PJL Technical Reference Documentation Package* for symbol set charts or for more information (page 10).

³The preferred method is to use the primary pitch command.

Regulatory Information

FCC Regulations

This equipment has been tested and found to comply with the limits for a Class B digital device, pursuant to Part 15 of the FCC rules. These limits are designed to provide reasonable protection against harmful interference in a residential installation. This equipment generates, uses, and can radiate radio frequency energy. If this equipment is not installed and used in accordance with the instructions, it may cause harmful interference to radio communications. However, there is no guarantee that interference will not occur in a particular installation. If this equipment does cause harmful interference to radio or television reception, which can be determined by turning the equipment off and on, the user is encouraged to try to correct the interference by one or more of the following measures:

- Reorient or relocate the receiving antenna.
- Increase separation between equipment and receiver.
- Connect equipment to an outlet on a circuit different from that to which the receiver is located.
- Consult your dealer or an experienced radio/TV technician.

Note

Any changes or modifications to the printer that are not expressly approved by HP could void the user's authority to operate this equipment.

Use of a shielded interface cable is required to comply with the Class B limits of Part 15 of FCC rules.

Environmental Product Stewardship

Protecting the Environment

Hewlett-Packard Company is committed to providing quality products in an environmentally-sound manner. The printer has been designed to minimize impacts on the environment.

The printer design eliminates:

Ozone Production	The printer uses charging rollers in the electrophotographic process and therefore generates no appreciable ozone gas (O ₃).
CFC Usage	Class I U.S. Clean Air Act stratospheric ozone-depleting chemicals (chlorofluorocarbons [CFCs], for example) have been eliminated from the manufacturing of the printer and packaging.

The printer design reduces:

Energy Consumption	Energy usage drops from 325 watts (W) during printing to as little as 21 W while in low-power (PowerSave) mode. This saves energy without affecting the high performance of the printer. This product qualifies for the ENERGY STAR Program (U.S. and Japan). ENERGY STAR is a voluntary program established to encourage the development of energy-efficient office products. The ENERGY STAR name is a registered service mark of the U.S. Environmental Protection Agency.
---------------------------	---



As an ENERGY STAR partner, Hewlett-Packard Company has determined that this product meets ENERGY STAR Guidelines for energy efficiency.

Toner Consumption	EconoMode uses about 50% less toner, thereby extending the life of the toner cartridge.
Paper use	The printer's optional duplexing feature, which provides for two-sided printing, reduces paper usage and the resulting demands on natural resources.

The design of the printer facilitates the recycling of:

Plastics

Europe Only: Plastic parts have material identification markings, according to international standards, which enhance the ability to identify plastics for proper disposition at the end of the printer's life. The plastics used in the printer housing and chassis are technically recyclable.

All Other Countries: Plastic parts have material identification markings, according to international standards, which enhance the ability to identify plastics for proper disposition at the end of the printer's life.

HP Toner Cartridges/ Photo-conductive Drum

In many countries, the toner cartridge/drum can be returned to HP at the end of its useful life. A prepaid shipping label and instructions on how to return the toner cartridge/drum are included with the replacement toner cartridge/drum. If your country is not listed in the replacement's brochure, call your local HP Sales and Service Office for further instructions. (See page 110 or the HP support pages at the front of this user's guide.)

HP Cartridge Recycling Program Information

Since 1990, the HP LaserJet Toner Cartridge Recycling Program has collected more than twelve million cartridges that otherwise would have been discarded into landfills or similar facilities. This rapidly growing program returns used cartridges to the manufacturing process, thus conserving a variety of resources. Once a cartridge is returned through the prepaid return program, it is disassembled. The reusable components and the plastic housing are cleaned and inspected for quality conformance. After passing strict inspection procedures, materials such as nuts, screws, and clips are reclaimed and used to produce new cartridges. Remaining materials, like the photoconductive drum, are melted down and used as raw materials for a variety of other products. By the weight of the materials returned, over 95% are recycled. All HP LaserJet toner cartridges are shipped in recycled boxes with the entire box being recyclable through the returns program. Styrofoam end caps, which were used to support HP LaserJet toner cartridges during shipping, have been replaced with molded end caps made from 100% post-consumer paper products. For more information in the U.S., call (1) (800) LASERJET [(1) (800) 527-3753]. International customers can call their local HP Sales and Service Office for further information regarding the HP Toner Cartridge Recycling Program (page 110).

The diagram below represents how HP LaserJet toner cartridges are recycled:



Printer and Parts

U.S. Only: HP's Hardware Recycling Organization will accept the printer and other HP products when you have no further use for them. HP disposes of these products in an environmentally-sound manner. Many of the functional parts are recovered, tested, and reused as fully warranted service parts. Used parts are not placed into new product manufacturing. The remainder of the product parts which are not functional are recycled if possible. For this service, call (1) (800) 535-7933.

Europe Only: Design for recycling has been incorporated into the printer and its accessories. The number of materials has been kept to a minimum while ensuring proper functionality and high product reliability. Dissimilar materials have been designed to separate easily. Fasteners and other connections are easy to locate, access, and remove with common tools. High priority parts have been designed to be accessed quickly for efficient disassembly and repair. Plastic parts have been primarily designed in two colors to enhance recycling options. A few small parts are colored specifically to highlight customer access points.

HP disposes of returned products in an environmentally sound manner. Many of the functional parts are recovered, tested, and reused as fully-warranted service parts. Used parts are not placed into new product manufacturing. The remainder of the product parts are recycled, if possible. For product take-back information, contact your local HP Sales and Service Office (page 110).

Paper

Europe Only: The printer is suited for the use of recycled papers when the paper meets the guidelines outlined in the *HP LaserJet Printer Family Paper Specifications Guide*. The printer is suited for the use of recycled paper according to DIN 19 309.

All Other Countries: The printer is suited for the use of recycled papers when the paper meets the guidelines outlined in the *HP LaserJet Printer Family Paper Specifications Guide*.

To ensure printer longevity, HP provides the following:

Extended Warranty HP SupportPack covers the printer and all HP-supplied internal components. It is a three-year warranty from the date of purchase. HP SupportPack must be purchased by the customer within 30 days of product purchase. Information on HP SupportPack is available by calling your local HP FIRST number. (See the HP Support pages at the front of this user's guide.)

Spare Parts and Consumables Availability Spare parts and consumable supplies for this product will be made available for at least five years after production has stopped.

Toner Material Safety Data Sheet

The Toner Material Safety Data Sheet can be obtained by calling your local HP FIRST number. (See the HP Support pages at the front of this user's guide.)

Declaration of Conformity

according to ISO/IEC Guide 22 and EN45014

Manufacturer's Name: Hewlett-Packard Company
Manufacturer's Address: 11311 Chinden Boulevard
Boise, Idaho 83714-1021, USA

declares, that the product

Product Name: HP LaserJet 5000, 5000 N, 5000 GN
Model Numbers: C4110A, C4111A, C4112A
Product Options: ALL

conforms to the following Product Specifications:

Safety: IEC 950:1991+A1+A2+A3 / EN 60950:1992+A1+A2+A3
IEC 825-1:1993 / EN 60825-1:1994 Class 1 (Laser/LED)

EMC: CISPR 22:1993+A1 / EN 55022:1994 Class B ¹⁾
EN 50082-1:1992
IEC 801-2:1991 / prEN 55024-2:1992 - 4 kV CD, 8 kV AD
IEC 801-3:1984 / prEN 55024-3:1991 - 3 V/m
IEC 801-4:1988 / prEN 55024-4:1992 - 0.5 kV Signal Lines
1.0 kV Power Lines

IEC 1000-3-2:1995 / EN61000-3-2:1995
IEC 1000-3-3:1994 / EN61000-3.3:1995
FCC Title 47 CFR, Part 15 Class B ²⁾ / ICES-003, Issue 2 / VCCI-2 ¹⁾
AS / NZS 3548:1992 / CISPR 22:1993 Class B ¹⁾

Supplementary Information:

The product herewith complies with the requirements of the following Directives and carries the CE-marking accordingly:

- the EMC directive 89/336/EEC
- the Low Voltage Directive 73/23/EEC

1. The product was tested in a typical configuration with Hewlett-Packard Personal Computer Systems.
2. This Device complies with Part 15 of the FCC Rules. Operation is subject to the following two conditions: (1) this device may not cause harmful interference, and (2) this device must accept any interference received, including interference that may cause undesired operation.

January 15, 1997

For Compliance Information ONLY, contact:

Australia Contact: Product Regulations Manager, Hewlett-Packard Australia Ltd.,
31-41 Joseph Street, Blackburn, Victoria 3130, Australia

European Contact: Your Local Hewlett-Packard Sales and Service Office or
Hewlett-Packard GmbH, Department HQ-TRE / Standards
Europe, Herrenberger Straße 130, D-71034 Böblingen (FAX:
+49-7031-14-3143)

USA Contact: Product Regulations Manager, Hewlett-Packard Company, PO
Box 15 Mail Stop 160, Boise, ID 83707-0015 (Phone:
208-396-6000)

Safety Statements

Laser Safety Statement

The Center for Devices and Radiological Health (CDRH) of the U.S. Food and Drug Administration has implemented regulations for laser products manufactured since August 1, 1976. Compliance is mandatory for products marketed in the United States. The printer is certified as a “Class 1” laser product under the U.S. Department of Health and Human Services (DHHS) Radiation Performance Standard according to the Radiation Control for Health and Safety Act of 1968. Since radiation emitted inside the printer is completely confined within protective housings and external covers, the laser beam cannot escape during any phase of normal user operation.

WARNING!

Using controls, making adjustments, or performing procedures other than those specified in this user’s guide may result in exposure to hazardous radiation.

Canadian DOC Regulations

Complies with Canadian EMC Class B requirements.

<<Conforme à la classe B des normes canadiennes de compatibilité électromagnétiques. << CEM>>.>>

VCCI Statement (Japan)

この装置は、情報処理装置等電波障害自主規制協議会（VCCI）の基準に基づく第二種情報技術装置です。この装置は、家庭環境で使用することを目的としていますが、この装置がラジオやテレビジョン受信機に近接して使用されると、受信障害を引き起こすことがあります。

取り扱い説明書に従って正しい取り扱いをして下さい。

Laser Statement for Finland

LASERTURVALLISUUS

LUOKAN 1 LASERLAITE KLASS 1 LASER APPARAT

HP LaserJet 5000, 5000 N, 5000 GN -laserkirjoitin on käyttäjän kannalta turvallinen luokan 1 laserlaite. Normaalisissa käytössä kirjoittimen suojakotelointi estää lasersäteen pääsyn laitteen ulkopuolelle.

Laitteen turvallisuusluokka on määritetty standardin EN 60825-1 (1993) mukaisesti.

VAROITUS !

Laitteen käyttäminen muulla kuin käyttöohjeessa mainitulla tavalla saattaa altistaa käyttäjän turvallisuusluokan 1 ylittävälle näkymättömälle lasersäteilylle.

VARNING !

Om apparaten används på annat sätt än i bruksanvisning specificerats, kan användaren utsättas för osynlig laserstrålning, som överskrider gränsen för laserklass 1.

HUOLTO

HP LaserJet 5000, 5000 N, 5000 GN -kirjoittimen sisällä ei ole käyttäjän huollettavissa olevia kohteita. Laitteen saa avata ja huoltaa ainoastaan sen huoltamiseen koulutettu henkilö. Tällaiseksi huoltotoimenpiteeksi ei katsota väriainekasetin vaihtamista, paperiradan puhdistusta tai muita käyttäjän käsikirjassa lueteltuja, käyttäjän tehtäväksi tarkoitettuja ylläpitotoimia, jotka voidaan suorittaa ilman erikoistyökaluja.

VARO !

Mikäli kirjoittimen suojakotelo avataan, olet alttiina näkymättömälle lasersäteilylle laitteen ollessa toiminnassa. Älä katso säteeseen.

VARNING !

Om laserprinterns skyddshölje öppnas då apparaten är i funktion, utsättas användaren för osynlig laserstrålning. Betrakta ej strålen.

Tiedot laitteessa käytettävän laserdiodin säteilyominaisuuksista:

Aallonpituus 770-795 nm
Teho 5 mW
Luokan 3B laser

Glossary

adjustable tray	A paper tray that is able to adapt to more than one size of media. All trays used in the printer are adjustable.
DIMM (dual in-line memory module)	A circuit board that holds extra memory chips for the printer.
drag-and-drop	The ability to execute a function graphically without typing a command. For example, in the Windows 95 Explorer, you can copy or move a file by “dragging” it from one folder and “dropping” it into another.
duplex printing accessory (also called “duplexer”)	An optional accessory used for automatically printing on both sides of a sheet of paper.
enhanced input/output (EIO)	Printer accessory slots used for transferring data between the computer and printer. Modular I/O (MIO) accessories for older printers and the newer EIO technology are not compatible.
media	Any material to be printed, including envelopes, labels, transparencies, and all types of paper. (Paper types include letterhead, prepunched, recycled, bond, color stock, card stock, and preprinted.)
full-bleed	Print that extends from edge to edge of a sheet of paper. This effect is achieved by printing on larger paper, then trimming to the edge of the printed image.
Mopier	An HP LaserJet printer equipped to deliver multiple original prints (or generate copies of a print job).
PCL	HP’s printer control language.
PostScript Emulation	See <i>PS</i> .
preprinted	Having pre-designed forms already printed on the paper.
printer driver	Program files that allow a software application to communicate with the printer and use its features.
printer driver help	On-screen instructions regarding the use of the printer driver.

printer software	Any or all of the software shipped with the printer. The printer is packaged with a compact disc containing the software needed to access all of the printer's features. If the printer has been correctly set up, the appropriate software is already installed.
printer software help	On-screen instructions regarding the use of the printer software. Help screens which can be activated from the Help button (or a question mark symbol) in the printer software.
PS	PostScript Level 2 Emulation (or Level 1 Emulation for Windows 3.1x). A printer language provided with the printer.
size	In this user's guide, paper size refers to the dimensions of a sheet of paper or other print media.
software application	A computer program or package developed for sale to the general public.
source	In this user's guide, paper source refers to the paper tray where paper or other print media is loaded.
type	In this user's guide, paper type refers to the unique properties of paper or other print media, such as rough, transparency, labels, etc.
universal tray	A paper tray that can be adjusted for many paper sizes.
watermark	Text printed on the background of a page.

Index

Numerics

- 1200 dpi B-5
- 250-sheet tray
 - loading 31– 32
 - ordering 8
 - paper orientation 41
 - paper specifications A-4
- 2-sided printing, *see* duplex printing accessory
- 2-up printing 57
- 300 dpi B-5
- 3-hole punched paper
 - duplexing 38
 - orientation 40– 41
- 500-sheet tray (optional)
 - loading 33– 34, 48, 51– 54
 - ordering 8
 - paper orientation 41
 - paper
 - specifications A-2, A-5– A-7
- 600 dpi B-5

A

- A4, rotated, printing 47– 48
- Access Denied Menus Locked message 13, 79
- accessories
 - ordering 8– 10
 - types of 7
 - verifying installation 101– 102
 - warranty 105– 106
- accessory connector 6
- acoustic emissions A-18
- adapters
 - ordering 9
 - pin connections A-20
- additional drivers, obtaining 14
- adhesive on envelopes,
 - printing with A-11
- adjusting memory settings C-6
- adjusting paper stop 29
- advanced printing
 - tasks 25, 56– 61
- allocating memory to printer language B-11, C-6
- Append CR To LF setting B-9
- Attention light 11
- authorized dealers, locating,
 - see* front pages iii
- Auto Continue

- setting 79, B-12
- AutoCAD printer driver 16

B

- Background Printing (Macintosh) 98
- backlight, turning off B-10
- Bad Duplexer Connection message 79
- Bad Optional Tray Connection message 79
- Bad Serial Transmission message 85
- basic printing tasks 25
- baud rate B-17
- benefits, printer 2– 3
- bidirectional parallel communication setting B-16
- Binding setting 39, B-4
- bit transmission A-19
- blank configuration page,
 - troubleshooting 92
- blank display,
 - troubleshooting 91
- both sides, printing with duplex accessory, *see* duplex printing accessory
- buffer, changing size C-7

C

- cables, serial
 - ordering 9
 - pin outs A-21
 - specifications A-19– A-21
 - troubleshooting 93, 96
 - types of A-20
- Canadian DOC regulations E-8
- Cancel Job key 12, B-20
- Cannot Duplex Rear Bin Open message 79
- capacity, paper tray A-3– A-6
- card stock A-12– A-13
 - see also* custom-size paper
- CFG EtherTalk setting B-19
- CFG Network setting B-18
- CFG Novell setting B-18
- CFG TCP/IP setting B-19
- changing
 - control panel setting 13
 - I/O buffer size C-7
 - paper type and size 60– 61
- characters
 - escape D-3
 - misformed 89– 90
- Check Input Device message 80
- CFC usage E-2
- Chooser, troubleshooting 97
- choosing driver 18
- Chosen Language Not Available message 80
- cleaning
 - paper path 69
 - printer 67– 68
- cleaning page
 - setting B-6
 - using 69
- Clearable Warnings
 - setting 79, B-12
- clearing
 - paper jams 72– 78
 - persistent messages 79
- combining escape sequences D-3
- commands, printer D-1– D-7
 - PCL D-5– D-7
 - selecting PCL fonts D-4
 - syntax D-2– D-3
- compact disc 14
- Configuration
 - Menu 79, B-10– B-14
- configuration page
 - printing 101– 102, B-2
 - sample 102
 - troubleshooting 92
- configurations
 - checking printer's 100– 103
 - printer 4– 5
 - printer's current B-1
- Configure Custom Paper message 53
- Configure Custom Paper setting B-7
- Configure Fuser Mode Menu setting B-4
- connectors, locating 6
- consumables, *see* supplies
- consumption, power A-17
- continue printing with low toner 65– 66
- control panel
 - keys 12
 - language 91
 - layout 11
 - lights 11, B-10
 - locating 6
 - locking 21

- menus B-1— B-20
- messages 79— 88
- printing current settings 13
- printing menu map 13, 100
- settings 13
- troubleshooting 91
- converting paper weights A-8
- Copies setting B-7
- Courier setting B-9
- creases, troubleshooting 89— 90
- Create Cleaning Page message 69
- Create Cleaning Page setting B-6
- curling paper, troubleshooting 89— 90, A-7
- current printer settings 13, 100— 103
- Custom Install option 15, 17
- customer support worldwide, *see* front pages v
- customizing Tray 1 operation 58— 59
- custom-size paper guidelines for printing 53
- margins 53
- orientation 41
- paper specifications A-3, A-5
- printing 28, 50— 54
- setting paper size 53— 54

D

- dark printing, setting toner density B-6
- Data light 11
- data, transmitting speed B-16, B-17
- dealers, locating HP authorized, *see* front pages iii
- Declaration of Conformity E-7
- default settings B-1 restoring B-20
- deleting fonts 19
- diagnostics, printer 22
- dial, paper size 31, 34
- dimensions, paper A-3— A-6
- dimensions, printer's A-14— A-16
- DIMMs accessories 7 installing C-1— C-5 ordering 9 printing font list 103
- Disk Device Failure message 80
- Disk File Operation Failed message 80
- Disk File System Is Full

- message 80
- Disk Is Write Protected message 80
- display, *see* control panel
- DLC/LLC setting B-18
- Do Not Power Off message 81
- documentation, ordering 10
- DOS, entering escape characters D-3
- double-side-seam envelopes, printing with A-11
- draft-quality printing B-6
- drivers, printer 14— 18 additional 16 help software 18 included with printer 15 Macintosh 15, 21 selecting 18 troubleshooting 93
- troubleshooting (Macintosh) 97
- Windows 17
- dropouts, troubleshooting 89— 90, A-7

- duplex printing accessory clearing paper jams 72, 76— 78 guidelines 36 ordering 8 paper orientation 38 paper specifications A-6 print layout options 39 printing with 35— 39 removing 37, C-4 troubleshooting 78, 96
- Duplex setting 36, B-4
- duplexer, *see* duplex printing accessory

E

- EconoMode setting B-6
- edge-to-edge printing, *see* full-bleed images
- EDO DIMMs, ordering 9 *see also* DIMMs
- EIO cards installing C-8 ordering 9
- EIO Menu B-18— B-19
- EIO x Bad Transmission message 85
- EIO x Buffer Overflow message 84
- electrical specifications A-17
- emissions, acoustic A-18
- energy consumption, *see* power consumption
- Energy Star E-2 envelopes adhesive strips or flaps A-11 double-side-seams A-11 guidelines 42

- margins 42, A-12 printing 28, 42— 43 printing from Tray 1 43 specifications A-10— A-12 storing A-12 wrinkled 42, A-10
- environmental product stewardship E-2— E-7
- environmental specifications A-17— A-18
- equivalent weights to US paper A-8
- error log, *see* event log
- error messages 79— 88 clearing repeated messages 79
- escape characters entering in DOS D-3 examples D-2
- escape sequences 103, D-3
- EtherTalk setting B-18
- event log 102, B-2
- expanding memory A-18, C-1— C-8

F

- face-down output bin 26
- face-up output bin 28
- faded print, troubleshooting 89— 90
- FastRes 1200 B-5
- FCC regulations E-1
- features, printer 2— 3
- feeding paper, problems with 95, A-7
- file directory B-2
- Finland's laser statement E-9
- 500-sheet tray (optional) loading 33— 34, 48, 51— 54 ordering 8 paper orientation 41 paper specifications A-2, A-5— A-7
- fixed-spaced fonts D-4
- flaps on envelopes, printing with A-11
- Flash Device Failure message 80
- flash DIMMs, ordering 9 *see also* DIMMs
- Flash File Operation Failed message 80
- Flash File System Is Full message 80
- Flash Is Write Protected message 81
- flowchart, troubleshooting for Macintosh 97— 98
- printer errors 91— 98
- fonts control panel settings B-8—

- B-9
- fixed-spaced D-4
- information about 103
- installing and deleting 19
- internal 103
- ordering DIMMs 9
- printing list of 103
- proportional-spaced D-4
- selecting PCL D-4
- soft 103
- troubleshooting
 - (Macintosh) 98
- FontSmart, *see* HP FontSmart
- format problems,
 - troubleshooting 94– 95
- gray background, solving 78
- full-bleed images, printing 49
- Fuser Error message 86

G

- garbled print,
 - troubleshooting 94, 95
- Go key 12
- graphics, vector D-1
- gray background,
 - troubleshooting 89– 90, A-7
- guidelines
 - card stock A-13
 - custom-size paper 53
 - duplexing 36
 - envelopes 42
 - labels 44– 45, A-9
 - paper A-7
 - paper quality A-2
 - printing both sides 36
 - transparencies 46

H

- hard disk
 - installing C-8
 - ordering 9
 - printing font list 103
- hardware warranty 105– 106
 - options E-6
- heavy paper
 - printing 28, 50
 - specifications A-12– A-13
- Help button, in printer driver 18
- help screens 18
- HP Bulletin Board Service, *see* front pages iii
- HP FIRIST, *see* front pages iv
- HP FontSmart 19, C-8
- HP JetAdmin 22, 61
 - installing 14
- HP JetDirect print server card
 - configuring network parameters B-18
 - installing C-8
 - ordering 9

- HP JetSend 20
- HP JobMonitor 19
- HP LaserJet Paper, ordering 8
- HP LaserJet Toner Cartridge
 - ordering 8
 - recycling program E-3
- HP LaserJet Utility 21
- HP Maintenance Agreement 106
- HP Software License Terms 109
- HP SupportPack 106, E-6
- HP support, *see* front pages iii– v
- HP ToolBox 19
- HP worldwide sales and service offices 110– 113
- HP-GL/2 commands D-1
- HP-UX 22
- humidity specifications A-18

I

- incorrect fonts 94, 95, 98
- index cards A-13
 - see also* custom-size paper
- Information Menu B-2
- information pages, for troubleshooting 100– 103
- Input Device Condition message 81
- Input Device Failure message 87
- input tray areas
 - paper jams, clearing 73
 - troubleshooting 96
- Install Tray message 81
- installed personalities and options, displayed on configuration page 102
- installing
 - drivers 15
 - EIO cards C-8
 - fonts 19
 - HP FontSmart 19
 - HP JetAdmin 14, 22
 - HP JetSend 20
 - mass storage devices C-8
 - memory C-2– C-5
 - software 14
 - toner cartridges 64
- Insufficient Memory message 84
- interface accessories
 - ordering 9
 - troubleshooting 93
- internal fonts 103, B-8
- IP addresses, current 102
- Item key 12
- I/O Buffer setting B-15
- I/O buffer, changing size C-7
- I/O cards
 - installing C-8

- ordering 9
- I/O Menu B-15– B-17
- I/O Timeout setting B-15

J

- Jam Recovery setting B-14
- JetAdmin, *see* HP JetAdmin
- JetSend, *see* HP JetSend
- Job Cancel key, *see* Cancel Job key
- JobMonitor, *see* HP JobMonitor

K

- keys, control panel 12

L

- labels
 - guidelines A-9
 - printing 28, 44– 45
 - solving repeated jams 78
 - specifications A-9
- landscape, orientation B-8
- languages, control panel 91
- languages, printer (personality)
 - allocating memory to B-11, C-6
 - selecting default B-10
 - switching 18, B-10
- laser safety statement E-8
- laser statement for Finland E-9
- LaserJet paper, *see* HP LaserJet Paper
- LaserJet Utility, *see* HP LaserJet Utility
- LaserWriter printer driver 21
- latest drivers, obtaining 14
- layout options
 - duplexing 39
 - printing multiple pages on one sheet 57
- letterhead paper
 - duplexing 38
 - orientation 40– 41
- letter, rotated, printing 47– 48
- license for software 109
- light printing
 - setting toner density B-6
 - troubleshooting 89– 90
- lights
 - control panel 11
 - turning off (PowerSave) B-10
- lightweight paper, printing with 28
- lines, troubleshooting 89– 90
- loading
 - custom-size paper 51– 52
 - envelopes 43
 - paper trays 30– 34

- Loading Program message 81
- locating paper jams 72
- locking control panel 21
- locking out paper trays 60
- loose toner,
 - troubleshooting 89–90, A-7

M

- Macintosh
 - network cable kit, ordering 9
 - PPDs 15, 21, 99
 - printer drivers 15, 21
 - selecting alternate PPD 99
 - serial cable, ordering 9
 - software for 21
 - troubleshooting
 - flowchart 97–98
- maintaining the printer 63–69
- maintenance message 63, 82
- Maintenance Message setting B-14
- Manual Feed setting B-4
- Manually Feed message 81
- manually feeding paper 59
- manuals, ordering 10
- margins
 - custom-size paper 53
 - envelopes 42, A-12
- mass storage devices
 - installing C-8
 - ordering 9
- material safety data sheet E-6
- maximum paper size 50, A-3–A-6
- media, *see* paper
- memory
 - allocated to printer
 - languages B-11, C-6
 - changing I/O buffer size C-7
 - changing resource
 - saving C-6
 - checking installation C-5
 - expansion A-18, C-1–C-8
 - information on configuration
 - page 102
 - installation location 6
 - installing DIMMs C-2–C-5
 - installing mass storage
 - device C-8
 - ordering 9
- Memory Full Stored Data Lost message 81
- Memory Settings Changed message 82
- Memory Shortage Job Cleared message 82
- Memory Shortage Page Simplified message 82
- Menu key 12
- menu map B-2
 - printing 13, 100

- menu tree, *see* menu map
- menus, control panel B-1–B-20
- messages, printer 71, 79–88
- MEt B-12
- Minimum Install option 15
- minimum paper size 50, A-3–A-6
- misformed characters,
 - troubleshooting 89–90
- Mopier Mode setting B-13
- MS Windows 3.1, 95, or NT
 - help 18
 - network software 22
 - printer drivers 15
 - software 14–20, 22–23
- multi-purpose paper,
 - ordering 8
- multi-purpose tray, *see* Tray 1

N

- networks
 - HP JetAdmin 14, 22
 - ordering I/O cards 9
 - software for 14, 22
 - troubleshooting
 - Macintosh 97
 - troubleshooting print
 - problems 93–98
- no jobs print,
 - troubleshooting 93
- noise emissions, *see* acoustic emissions
- Novell NetWare 22
- Novell setting B-18
- n-up printing 57
- NVRAM Error Check Settings message 87
- NVRAM Full Check Settings message 87

O

- Offline message 82
- online help 18
- online services, *see* front pages iii
- operating temperature A-18
- optional 500-sheet tray, *see* 500-sheet tray (optional)
- optional accessories
 - ordering 7–10
 - tray configurations 5
 - troubleshooting 96
 - verifying installation 101–102
 - warranty 105–106
- optional duplex printing
 - accessory, *see* duplex printing accessory
- optional paper tray, *see* 250-sheet tray *or see*

- 500-sheet tray (optional)
- orientation
 - paper 40–41
 - portrait or landscape B-8
 - printing both sides of
 - paper 38
- Orientation setting B-8
- OS/2 printer drivers 16
- output areas
 - clearing paper jams 75
 - troubleshooting 96
- output bin 26–28
- Override A4 With Letter setting B-4
- overriding printer settings 17
- ozone production E-2

P

- page count, printer 102
- Page Protect setting B-12
- page skew,
 - troubleshooting 89–90
- Page Too Complex message 84
- paper
 - card stock A-12–A-13
 - changing type and size 60–61
 - clearing jams 72–78
 - converting paper
 - weights A-8
 - creases,
 - troubleshooting 89–90
 - curl, troubleshooting 89–90, A-7
 - custom-size 28, 50–54, A-3, A-5
 - guidelines A-7
 - heavy A-12–A-13
 - HP brand 8
 - jams, correcting A-7
 - manually feeding 59
 - ordering 8
 - orientation 40–41
 - printing by type and
 - size 60–61
 - problems with 89–90, A-7
 - recycling E-5
 - rotated, printing 47–48
 - sizes supported A-3–A-6
 - special types 40–55
 - specifications A-2–A-13
 - types supported A-6
 - using recycled E-5
 - weight equivalence
 - table A-8
 - weight specifications A-3–A-6
- Paper Handling Menu B-3–

- B-4
- Paper Jam message 84
- paper jams 72– 78
 - duplexer 76– 77
 - input tray areas 73
 - locating 72
 - output areas 75
 - repeated jams 78
 - top cover area 74
 - Tray 1 73
- Paper Path Open Please Close
 - It message 80
- paper path test B-2
- paper path, cleaning 69
- Paper setting B-7
- paper size dial, locating 31, 34
- paper stop, adjusting 29
- paper trays
 - clearing paper jams 72– 78
 - current size settings 102
 - customizing Tray 1 58– 59
 - extension 30
 - loading 30– 34
 - locking out 60
 - multi-purpose 30
 - ordering 8
 - solving repeated jams 78
 - troubleshooting 96
- Parallel Adv Function
 - setting B-16
- parallel cables, ordering 9
- Parallel High Speed
 - setting B-16
- parallel interface connector,
 - locating 6
- Parallel I/O Buffer Overflow
 - message 84
- parts, locating 6
- PCL
 - commands D-1– D-7
 - printing font list 103, B-2
 - selecting fonts D-4
 - syntax D-2– D-3
- PCL 5e drivers 15
 - function 18
- PCL 6 drivers 15
 - function 18
- PCL Font Number setting B-8
- PCL Font Pitch setting B-8
- PCL Font Point Size
 - setting B-9
- PCL Font Source setting B-8
- PCL Memory setting B-11
- PCL Symbol Set setting B-9
- Perform Printer Maintenance
 - message 82
- permanent fonts
 - downloaded 103
 - setting B-8
- Personality setting B-10
- personality, *see* languages,
 - printer (personality)
- photoconductive drum E-3
- physical dimensions,
 - printer's A-14– A-16
- pin connections A-20
- pin outs
 - serial cables A-21
- pitch/point information 103
- PJL commands D-1
- portrait, orientation B-8
- ports
 - troubleshooting 93
- postcards A-12– A-13
 - see also* custom-size paper
- PostScript emulation, *see* PS
- PostScript Printer Description
 - files, *see* PPDs
- power connector, locating 6
- power consumption A-17
- power switch, locating 6
- PowerSave mode E-2
- PowerSave setting B-10
- PPDs
 - Macintosh 21
 - selecting alternate 99
- preprinted/prepunched paper
 - duplexing 38
 - orientation 40– 41
- Print PS Errors setting 93, B-9
- Print Quality Menu B-5– B-6
- print quality problems 89–
 - 90, A-7
- print queue, viewing 19
- print resolution B-5
- print speed A-18, B-5
- printer
 - adapters A-20
 - cleaning 67– 69
 - commands D-1– D-7
 - configuration 100– 103
 - control panel layout 11– 13
 - diagnostics 22
 - dimensions A-14– A-16
 - drivers 14– 18
 - drivers, Macintosh 15, 21
 - errors, troubleshooting 71–
 - 103
 - features 2– 3
 - help software 18
 - information pages 100–
 - 103
 - maintenance 63– 69
 - managing through
 - network 22
 - memory C-1– C-8
 - menu map 13
 - messages 71, 79– 88
 - operating temperature A-18
 - ordering supplies 8– 10
 - output bins 26– 28
 - overriding control panel
 - settings 17
 - paper size dial 31, 34
 - parts and location 6
 - PCL commands D-1– D-7
 - physical dimensions A-14–
 - A-16
 - relative humidity A-18
 - renaming 99
 - sales and service
 - offices 110– 113
 - saving setup 56
 - settings, current 100– 103
 - software 14– 23
 - specifications A-14– A-18
 - status, accessing 19
 - see also* messages
- printer drivers 14– 18
 - additional 16
 - help software 18
 - included with printer 15
 - Macintosh 15, 21
 - selecting 18
 - troubleshooting 93
 - troubleshooting
 - (Macintosh) 97
 - Windows 17
- Printer Error messages 86–
 - 88
- printer languages
 - allocating memory
 - to B-11, C-6
 - drivers 18
 - selecting default B-10
- printing 25– 61
 - advanced tasks 56– 61
 - basic tasks 25– 55
 - configuration page 101–
 - 102
 - custom-size paper 50– 54
 - duplexing 35– 39
 - edge-to-edge, *see* full-bleed
 - images
 - envelopes 42– 43, A-10–
 - A-12
 - first page on different
 - paper 57
 - font list 103
 - full-bleed images 49
 - heavy paper 50
 - labels 44– 45
 - manually feeding paper 59
 - menu map 13, 100
 - multiple pages on one
 - sheet 57
 - output bins 26– 28
 - rotated paper 47– 48
 - special paper 40– 55
 - speed A-18, B-5
 - supplies, ordering 8
 - transparencies 46
 - vellum 55
 - watermark 56
 - with low toner 65– 66

- Printing Menu B-7– B-9
- problem solving, printer errors 71– 103
- Process Cleaning Page setting B-6
- product return 105– 106, 108
- Product Stewardship
 - acoustic emissions A-18
 - consumables, *see* supplies
 - energy consumption, *see* power consumption
 - memory expansion C-2– C-5
 - noise emissions, *see* acoustic emissions
 - paper
 - specifications A-2– A-13
 - using recycled E-5
 - parts supply 8– 10, E-6
 - photoconductive drum E-3
 - power
 - consumption A-17, E-2
 - product return 105– 106, 108
 - product take back, *see* product return
 - return 105– 106, 108
 - supplies
 - availability 7– 10, E-6
 - paper 8
 - toner cartridge 8, 64– 66, 107, E-2– E-3, E-6
 - using recycled paper E-5
 - warranty
 - options E-6
 - standard 105– 106
- product take back, *see* product return
- proportional-spaced fonts D-4
- ProRes 1200 B-5
- PS
 - allocating memory to B-11, C-6
 - drivers
 - function 18
 - included with printer 15
 - printing font list 103, B-2
 - troubleshooting error page 93
- PS Memory setting B-11
- Q**
 - quality, print
 - problems 71, 89– 90, A-7
 - with low toner 65– 66
- Quick Sets 56
- R**
 - Ram Disk Device Failure message 82
 - Ram Disk File Operation
 - Failure message 82
 - Ram Disk File System Is Full message 83
 - Ram Disk Is Write Protected message 83
 - Ram Disk setting B-13
 - Ram Disk Size setting B-13
 - Ready light 11
 - rear door latches, locating 6
 - rear output bin
 - clearing paper jams 75
 - locating 6
 - using 28
 - recycled paper, using E-5
 - recycling used toner
 - cartridges 64, E-3– E-4
 - redistributing toner 65– 66
 - regulatory information E-1– E-9
 - relative humidity A-18
 - removing duplex printing
 - accessory 37, C-4
 - renaming the printer 99
 - repeated paper jams, solving 78
 - repeating defects, troubleshooting 89– 90
 - Reset Active I/O Channel setting B-20
 - Reset All I/O Channels setting B-20
 - Reset Memory setting B-20
 - Resets Menu B-20
 - Resolution Enhancement technology (REt) setting B-5
 - Resolution setting B-5
 - Resource Save setting B-11
 - resource saving, allocating memory C-6
 - restore default settings B-20
 - Restore Factory Settings B-20
 - REt setting B-5
 - return 105– 106, 108
 - rotated paper, printing 47– 48
- S**
 - safety statements E-8– E-9
 - sales and service offices 110– 113
 - samples
 - configuration page 102
 - print quality problems 89
 - saving
 - paper E-2
 - power B-10, E-2
 - printer setup 56
 - toner B-6, E-2
 - SDRAM DIMMs, ordering 9
 - see also* DIMMs
 - security, information 102
 - Select key 12
 - serial adapter, ordering 9
 - Serial Baud Rate setting B-17
 - serial cables
 - ordering 9
 - pin outs A-21
 - troubleshooting 93
 - types of A-20
 - Serial DTR Polarity setting B-17
 - serial interface connector, locating 6
 - Serial I/O Buffer Overflow message 85
 - serial number 102
 - Serial Pacing setting B-16
 - Serial Robust XON setting B-16
 - service agreements 105– 106, E-6
 - see also* front pages iv
 - Service Information Form 108
 - service information, *see* front pages iii
 - setting
 - custom paper sizes 53– 54
 - paper type and size 60– 61
 - settings
 - affecting printer
 - messages 79
 - control panel 13, B-1– B-20
 - verifying current 100– 103
 - show event log B-2
 - 600 dpi B-5
 - size settings 30– 34, 47– 48, 50– 54, 58, 60– 61
 - size, paper A-3– A-6
 - slides, *see* transparencies
 - small paper, printing 28
 - see also* custom-size paper
 - soft fonts 103
 - software
 - drivers 14– 18, 21
 - help for drivers 18
 - HP FontSmart 19
 - HP JetAdmin 14, 22
 - HP JetSend 20
 - HP JobMonitor 19
 - HP LaserJet Utility for
 - Macintosh 21
 - HP ToolBox 19
 - included with printer 14
 - license 109
 - Macintosh 15, 21
 - networks 14, 22
 - troubleshooting print
 - problems 93
 - Windows 14– 20, 22– 23
 - Solaris 22
 - special paper
 - manually feeding 59

- printing 40– 55
- specifications
 - acoustic emissions A-18
 - card stock A-12– A-13
 - electrical A-17
 - envelopes A-10– A-12
 - general A-18
 - heavy paper A-12– A-13
 - labels A-9
 - paper A-2– A-13
 - printer A-14– A-18
 - serial cable A-19– A-21
 - transparencies A-9
 - vellum A-10
- speed
 - printing A-18, B-5
 - transmitting
 - data B-16, B-17
- status, *see* printer messages
- storing
 - envelopes A-12
 - toner cartridges 64
- straight-through paper path 28
- Sun OS 22
- supplies
 - availability 7– 10, E-6
 - ordering 8– 10
 - paper 8
- support agreements 105– 106, E-6
 - see also* front pages iv
- SupportPack, *see* HP SupportPack
- support, worldwide, *see* front pages v
- switching printer
 - languages 18, B-10
- syntax for printer
 - commands D-2– D-4

T

- TCP/IP protocol, setting B-19
- TCP/IP setting B-18
- 3-hole punched paper
 - duplexing 38
 - orientation 40– 41
- 300 dpi B-5
- toner
 - consumption E-2
 - density B-6
 - low, continue printing 65– 66
 - spilling 74
 - troubleshooting 89– 90, A-7
- toner cartridges 64– 66
 - life expectancy 64
 - limited warranty 107
 - material safety data
 - sheet E-6
 - ordering 8
 - recycling 64, E-3

- Toner Density setting B-6
- Toner Low message 65
- Toner Low setting B-12
- Toner Material Safety Data Sheet E-6
- ToolBox, *see* HP ToolBox
- top cover area, clearing paper jams 74
- top cover, locating 6
- top output bin
 - clearing paper jams 75
 - locating 6
 - using 26
- transmitting data,
 - speed B-16, B-17
- transparencies
 - printing 27, 46
 - solving repeated jams 78
 - specifications A-9
- Tray 1
 - customizing operation 58– 59
 - deselecting 96
 - envelope
 - specifications A-10– A-12
 - locating 6
 - mode settings 58– 59
 - paper jams, clearing 73
 - paper orientation 41
 - paper specifications A-3
 - printing envelopes 42– 43
 - printing paper 30
 - printing special paper 44– 47, 50, 53– 55
- Tray 1 Mode setting B-3
- Tray 1 Mode=Cassette 58
- Tray 1 Mode=First 58
- Tray 1 Size setting B-3
- Tray 1 Type setting B-3
- Tray 2
 - loading 31– 32
 - paper jams, clearing 73
 - paper orientation 41
 - paper specifications A-4
- Tray 2 Type setting B-3
- Tray 3 Type setting B-3
- Tray 4 Type setting B-3
- tray extension 30
- Tray x Empty message 83
- Tray x Load message 83
- troubleshooting 71– 103
 - flowchart 91– 98
 - Macintosh 97– 99
 - paper jams 72– 78
 - print quality problems 89– 90, A-7
 - printer messages 79– 88
 - repeated paper jams 78
 - using information
 - pages 100– 103

- TrueType fonts 19
- 1200 dpi B-5
- 250-sheet tray
 - loading 31– 32
 - ordering 8
 - paper orientation 41
 - paper specifications A-4
- 2-sided printing, *see* duplex printing accessory
- 2-up printing 57
- Type setting B-4
- type settings 60– 61, B-3
- Typical Install option 15, 17

U

- Unexpected Paper Sizes
 - message 85
- uninstalling fonts 19
- Unit of Measure setting B-7
- UNIX, *see* HP-UX
- Unsupported Size In Tray
 - message 83
- upgrading printer memory C-1
- Use x x Instead message 83
- user's guide, ordering 10

V

- Value key 12
- VCCI statement, Japan E-8
- vector graphics D-1
- vellum
 - printing 55
 - solving repeated jams 78
 - specifications A-10
- viewing print queue 19

W

- warranty
 - options E-6
 - standard 105– 106
 - toner cartridge, limited 107
- watermark, printing 56
- wavy paper,
 - troubleshooting 89– 90
- weight of printer A-16
- weight, paper A-3– A-6
- weight, paper equivalence
 - table A-8
- Wide A4 setting B-9
- Windows
 - help 18
 - network software 14, 22
 - printer drivers 15
 - software 14– 20, 22– 23
- Windows NT 3.51 PCL 5e
 - printer driver 16
- WordPerfect 5.1 printer
 - driver 16
- World Wide Web addresses,
 - see* front pages iii
- wrinkled paper,
 - troubleshooting 89–

90, A-10
wrong printer selected,
troubleshooting
(Macintosh) 98
wrong tray, troubleshooting 96

X

X Dimension setting B-8

Y

Y Dimension setting B-8



Copyright© 1998
Hewlett-Packard Co.
Printed in USA

Manual Part No.
C4110-90901



Printed on at least
50% Total Recycled Fiber with
at least 10% Post-Consumer Paper



C4110-90901