

HP Pavilion dv3000 Entertainment PC and HP
Pavilion dv3500 Entertainment PC
Maintenance and Service Guide



© Copyright 2008 Hewlett-Packard
Development Company, L.P.

Bluetooth is a trademark owned by its proprietor and used by Hewlett-Packard Company under license. Intel and Core are trademarks or registered trademarks of Intel Corporation or its subsidiaries in the United States and other countries. Microsoft, Windows, and Windows Vista are either trademarks or registered trademarks of Microsoft Corporation in the United States and/or other countries. SD Logo is a trademark of its proprietor.

The information contained herein is subject to change without notice. The only warranties for HP products and services are set forth in the express warranty statements accompanying such products and services. Nothing herein should be construed as constituting an additional warranty. HP shall not be liable for technical or editorial errors or omissions contained herein.

Second Edition: September 2008

First Edition: March 2008

Document Part Number: 463189-002

Safety warning notice

-
- ⚠ **WARNING!** To reduce the possibility of heat-related injuries or of overheating the computer, do not place the computer directly on your lap or obstruct the computer air vents. Use the computer only on a hard, flat surface. Do not allow another hard surface, such as an adjoining optional printer, or a soft surface, such as pillows or rugs or clothing, to block airflow. Also, do not allow the AC adapter to contact the skin or a soft surface, such as pillows or rugs or clothing, during operation. The computer and the AC adapter comply with the user-accessible surface temperature limits defined by the International Standard for Safety of Information Technology Equipment (IEC 60950).
-

Table of contents

1 Product description

2 External component identification

Top components	6
TouchPad	6
Lights	7
Buttons and fingerprint reader (select models only)	9
Keys	11
Front components	12
Right-side components	12
Left-side components	13
Bottom components	14
Display components	15
Wireless antennae	16

3 Illustrated parts catalog

Serial number location	17
Computer major components	18
Display assembly components	24
Plastics Kit	26
Mass storage devices	27
Miscellaneous parts	28
Sequential part number listing	30

4 Removal and replacement procedures

Preliminary replacement requirements	36
Tools required	36
Service considerations	36
Plastic parts	36
Cables and connectors	37
Drive handling	37
Grounding guidelines	38
Electrostatic discharge damage	38

Packaging and transporting guidelines	39
Workstation guidelines	39
Equipment guidelines	40
Unknown user password	41
Component replacement procedures	42
Serial number	42
Computer feet	43
Battery	43
WLAN module	45
Optical drive	48
Memory module	49
Hard drive	51
Keyboard	54
Switch cover	57
Top cover	58
Fingerprint reader board	61
Display assembly	63
System board	70
Speakers	74
Bluetooth module	75
RTC battery	77
Modem module	79
Heat sink	80
Processor	82
Fan	84

5 Setup Utility

Starting the Setup Utility	86
Using the Setup Utility	87
Changing the language of the Setup Utility	87
Navigating and selecting in the Setup Utility	87
Displaying system information	88
Restoring default settings in the Setup Utility	88
Exiting the Setup Utility	88
Setup Utility menus	89

6 Specifications

Computer specifications	91
13.3-inch, WXGA, BrightView display specifications	92
Hard drive specifications	93
DVD±RW and CD-RW Super Multi Double-Layer Combo Drive specifications	94
DVD/CD-RW Combo Drive specifications	95
System DMA specifications	96

System memory map specifications	96
System interrupt specifications	97
System I/O address specifications	98

7 Screw listing

Phillips PM3.0×4.0 screw	100
Phillips PM2.5×6.0 captive screw	101
Black Phillips PM2.5×4.0 screw	102
Phillips PM2.5×11.0 captive screw	103
Phillips PM2.0×4.0 screw	104
Phillips PM2.5×7.0 screw	106
Phillips PM2.5×5.0 screw	108
Phillips PM2.0×3.0 captive screw	110
Silver Phillips PM2.5×4.0 screw	111
Phillips PM2.0×5.0 captive screw	112

8 Backup and recovery

Recovering system information	113
Creating recovery discs	113
Backing up your information	114
When to back up	114
Backup suggestions	115
Using system restore points	115
When to create restore points	115
Create a system restore point	115
Restore to a previous date and time	116
Performing a recovery	116
Recovering from the recovery discs	116
Recovering from the dedicated recovery partition (select models only)	116

9 Connector pin assignments

Audio-out (headphone)	118
Audio-in (microphone)	118
External monitor	119
RJ-11 (modem)	120
RJ-45 (network)	120
Universal Serial Bus	121

10 Power cord set requirements

Requirements for all countries or regions	122
Requirements for specific countries or regions	123

11 Recycling

Battery 124
Display 124

Index 130

1 Product description

Category	Description	dv3000	dv3500
Product Name	HP Pavilion dv3000 Entertainment PC	√	
	HP Pavilion dv3500 Entertainment PC		√
Processors	Intel® Core™2 Duo processors		
	T9500 2.60-GHz processor, 6-MB L2 cache, 800-MHz front side bus (FSB)	√	
	T9400 2.53-GHz processor, 6-MB L2 cache, 1066-MHz FSB		√
	T9300 2.50-GHz processor, 6-MB L2 cache, 800-MHz FSB	√	
	P8600 2.40-GHz processor, 3-MB L2 cache, 1066-MHz FSB		√
	P8400 2.26-GHz processor, 3-MB L2 cache, 1066-MHz FSB		√
	T8300 2.40-GHz processor, 3-MB L2 cache, 800-MHz FSB	√	
	T8100 2.10-GHz processor, 3-MB L2 cache, 800-MHz FSB	√	
	T7350 2.26-GHz processor, 3-MB L2 cache, 1066-MHz FSB		√
	T5900 2.20-GHz processor, 3-MB L2 cache, 800-MHz FSB		√
	T5850 2.16-GHz processor, 2-MB L2 cache	√	
	T5800 2.80-GHz processor, 3-MB L2 cache, 800-MHz FSB		√
	T5750 2.00-GHz processor, 2-MB L2 cache, 667-MHz FSB	√	
	T5550 1.80-GHz processor, 2-MB L2 cache, 667-MHz FSB	√	
	T3200 2.00-GHz processor, 1-MB L2 cache, 800-MH FSB		√
	Intel Pentium Dual Core processor		
	T2390 1.86-GHz processor, 1-MB L2 cache	√	
Chipsets	Northbridge: Intel PM965	√	
	Northbridge: Intel PM45		√
	Southbridge: Intel ICH8m	√	
	Southbridge: Intel ICH9m		√
Graphics	nVidia NB8M-GS discrete PCI Express X16 Graphics with 256 MB of dedicated video memory	√	
	nVidia NB9M-GS discrete PCI Express X16 Graphics with 512 MB of dedicated video memory		√

Category	Description	dv3000	dv3500
Panel	13.3-inch, WXGA with BrightView	√	√
	13.3-inch, WXGA with BrightView with lighted logo on top of bezel	√	√
Memory	2 SODIMM slots	√	√
	Customer-accessible/upgradable	√	√
	Supports up to 4 GB of system RAM	√	
	Supports up to 8 GB of system RAM		√
	Support for DDRII dual-channel 667- and 800-MHz	√	
	Support for:	√	
	<ul style="list-style-type: none"> • 4096-MB total system memory (2048 × 2) • 3072-MB total system memory (2048 × 1, 1024 × 1) • 2048-MB total system memory (2048 × 1) • 2048-MB total system memory (1024 × 2) • 1024-MB total system memory (1024 × 1, 512 × 2) 		
	Support for:		√
<ul style="list-style-type: none"> • 8192-MB total system memory (4096 × 2) • 4096-MB total system memory (2048 × 2) • 3072-MB total system memory (2048 × 1, 1024 × 1) • 2048-MB total system memory (1024 × 2) • 2048 MB (2048 × 1) • 1024-MB total system memory (1024 × 1) 			
Hard drives	Support for 9.5-mm, 2.5-inch hard drives	√	√
	Support for HP ProtectSmart Hard Drive Protection	√	√
	Serial ATA	√	√
	Support for the following drives:	√	
	<ul style="list-style-type: none"> • 320-GB, 5400-rpm • 250-GB, 5400-rpm • 160-GB, 5400-rpm • 120-GB, 5400-rpm 		
	Support for the following drives:		√
	<ul style="list-style-type: none"> • 500-GB, 5400-rpm • 400-GB, 5400-rpm • 320-GB, 5400-rpm • 250-GB, 5400-rpm • 160-GB, 5400-rpm 		

Category	Description	dv3000	dv3500
Optical drives	MultiBay II	√	√
	Serial ATA		√
	Parallel ATA	√	
	9.5-mm tray load	√	√
	Support for:	√	
	<ul style="list-style-type: none"> DVD±RW and CD-RW Super Multi Double-Layer Combo Drive DVD-CD/RW Combo Drive 		
	Support for:		√
	<ul style="list-style-type: none"> DVD±RW and CD-RW Super Multi Double-Layer Combo Drive 		
Webcam	Low light VGA webcam with activity light	√	
	VGA webcam with activity light		√
	Fixed (no tilt)	√	√
Microphones	Dual-array digital microphones	√	√
Audio	HP-branded Altec Lansing speakers	√	√
Modem	56K V.92 data/fax modem	√	√
	Modem cable not included	√	√
Ethernet	Integrated 10/100/1000 network interface card (NIC)	√	√
	Ethernet cable not included	√	√
Wireless	Integrated wireless local area network (WLAN) options by way of wireless module:		
	Intel PRO Wireless 4965 802.11a/b/g/n with Bluetooth®	√	
	Intel PRO Wireless 4965 802.11a/b/g/n	√	
	Intel PRO Wireless 3945 802.11a/b/g with Bluetooth	√	
	Intel PRO Wireless 3945 802.11a/b/g	√	
	Intel WiFi Link 5100 802.11a/b/g/n WLAN module		√
	Intel WiFi Link 5100 802.11a/b/g WLAN module		√
	Support for two wireless antennae integrated into the display assembly		√
	Support for three wireless antennae integrated into the display assembly	√	
External media cards	Secure Digital (SD) Memory Card, MultiMediaCard (MMC), Memory Stick (MS), Memory Stick Pro (MSP), xD-Picture Card (XD)	√	√
	Support for miniature versions of SD, MMC, MS Duo with adapter (adapter is not included)	√	√
Ports	Audio-in (mono microphone)	√	√
	Audio-out (stereo headphone) (2)	√	√
	Consumer infrared	√	√

Category	Description	dv3000	dv3500
	Extended serial advanced technology (eSATA)	√	√
	High-definition multimedia interface (HDMI) supporting 1080p with high-bandwidth digital content protection (HDCP) key	√	√
	RJ-11 (modem)	√	√
	RJ-45 (Ethernet, includes link and activity lights)	√	√
	USB (3)	√	
	USB (2), USB/eSATA combo port (1)		√
	VGA (Dsub, 15-pin) supporting 1600 × 1200 and 1920 × 1200 external resolution @ 75Hz, hot plug/unplug, and autodetect for correct output to wide-aspect vs. standard-aspect video	√	√
	2-pin, 90-W AC power	√	√
Docking	No docking	√	√
Keyboard/ pointing devices	30.48-cm (12.0-inch) keyboard	√	√
	Lighted keyboard		√
	TouchPad	√	√
	2-way scroll	√	√
	Taps enabled as default	√	√
Power requirements	<ul style="list-style-type: none"> 6-cell, 55-Wh, 2.55-Ah Li-ion battery 4-cell, 37-Wh, 2.55-Ah Li-ion battery 	√	√
	90-W HP Smart AC Adapter with localized cable plug support (2-wire plug with ground pin, supports 2-pin DC connector)	√	√
Security	Security cable slot	√	√
	Fingerprint reader with Digital Persona software support	√	√
Operating system	Preinstalled:		
	Configurable Windows Vista® with embedded QuickPlay Direct	√	
	Windows Vista Ultimate (64-bit)	√	√
	Windows Vista Premium (64-bit)		√
	Windows Vista Premium (32-bit)	√	√
	Windows Vista Business (32-bit)		√
Serviceability	End-user replaceable parts:		
	AC adapter	√	√
	Battery (system)	√	√
	Hard drive	√	√
	Memory module	√	√

Category	Description	dv3000	dv3500
	Optical drive	√	√
	WLAN module	√	√

2 External component identification

Top components

TouchPad

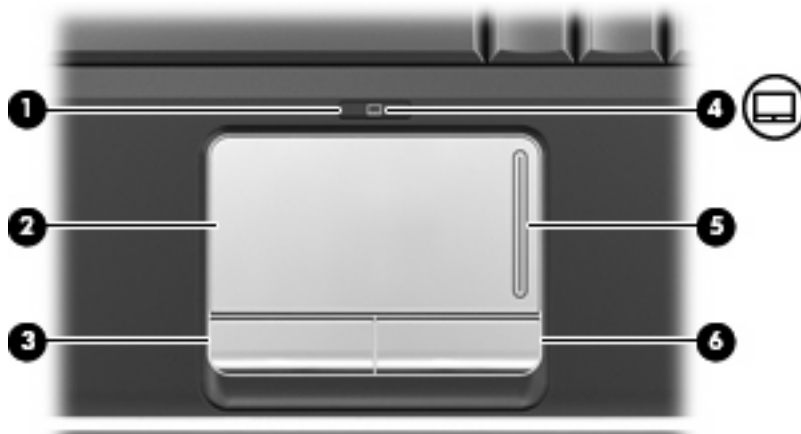

Component	Description
(1) TouchPad on/off button	Enables/disables the TouchPad.
(2) TouchPad*	Moves the pointer and selects or activates items on the screen.
(3) Left TouchPad button*	Functions like the left button on an external mouse.
(4) TouchPad light	<ul style="list-style-type: none">• White: TouchPad is enabled.• Amber: TouchPad is disabled.
(5) TouchPad scroll zone	Scrolls up or down.
(6) Right TouchPad button*	Functions like the right button on an external mouse.

*This table describes factory settings. To view and change pointing device preferences, select **Start > Control Panel > Hardware and Sound > Mouse**.

Lights

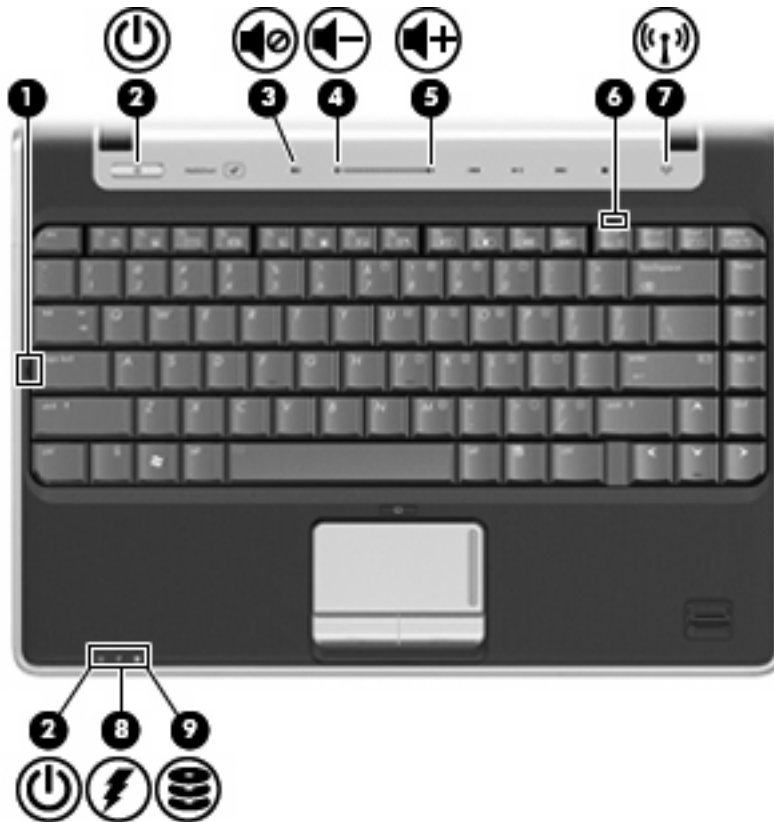

Component	Description
(1) Caps lock light	On: Caps lock is on.
(2) Power lights (2)*	<ul style="list-style-type: none"> On: The computer is on. Blinking: The computer is in the Sleep state. Off: The computer is off or in Hibernation.
(3) Volume mute light	<ul style="list-style-type: none"> White: Computer sound is on. Amber: Computer sound is off.
(4) Volume down light	On: The volume scroll zone is being used to decrease speaker volume.
(5) Volume up light	On: The volume scroll zone is being used to increase speaker volume.
(6) Num lock light	On: Num lock is on or the embedded numeric keypad is enabled.
(7) Wireless light	<ul style="list-style-type: none"> On: An integrated wireless device, such as a wireless local area network (WLAN) device and/or a Bluetooth® device, is on. Off: All wireless devices are off.

Component	Description
(8) Battery light	<ul style="list-style-type: none"> • On: A battery is charging. • Blinking: A battery that is the only available power source has reached a low battery level or a critical battery level. • Off: If the computer is plugged into an external power source, the light is turned off when all batteries in the computer are fully charged. If the computer is not plugged into an external power source, the light stays off until the battery reaches a low battery level.
(9) Drive light	Blinking: The hard drive or optical drive is being accessed.

*The 2 power lights display the same information. The light on the power button is visible only when the computer is open. The power light on the front of the computer is visible whether the computer is open or closed.

Buttons and fingerprint reader (select models only)



Component	Description
(1) Power button*	<ul style="list-style-type: none"> • When the computer is off, press the button to turn on the computer. • When the computer is on, press the button to initiate Sleep. • When the computer is in the Sleep state, press the button briefly to exit Sleep. • When the computer is in Hibernation, press the button briefly to exit Hibernation.
(2) Media button	<p>Launches the MediaSmart SmartMenu.</p> <p>NOTE: If the computer has been set up to require a logon password, you may be asked to log on to Windows. MediaSmart starts after you log on. For more information about MediaSmart, select Start > Help and Support.</p>
(3) Volume mute button	Mutes and restores speaker sound.
(4) Volume scroll zone	Adjusts speaker volume. Slide your finger to the left to decrease volume and to the right to increase volume. You can also tap the minus sign on the scroll zone to decrease volume, or tap the plus sign on the scroll zone to increase volume.

Component	Description
(5) Previous/rewind button	<ul style="list-style-type: none"> Plays the previous track or chapter when the button is pressed once. Rewinds media when the button is pressed in combination with the fn key.
(6) Play/pause button	Plays or pauses media.
(7) Next/fast forward button	<ul style="list-style-type: none"> Plays the next track or chapter when the button is pressed once. Fast forwards media when pressed in combination with the fn key.
(8) Stop button	Stops playback.
(9) Wireless button	<p>Turns the wireless feature on or off but does not create a wireless connection.</p> <p>NOTE: To establish a wireless connection, a wireless network must already be set up.</p>
(10) Fingerprint reader (select models only)	Allows a fingerprint logon to Windows, instead of a password logon.

*This table describes factory settings. For information about changing factory settings, refer to the user guides located in Help and Support.

Keys

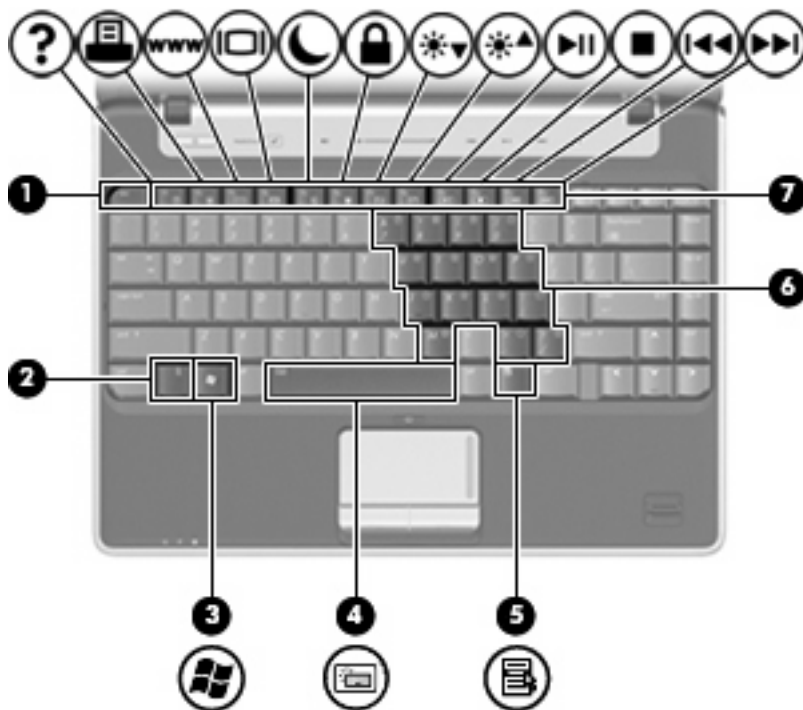

Component	Description
(1) esc key	Displays system information when pressed in combination with the fn key.
(2) fn key	Executes frequently used system functions when pressed in combination with a function key or the esc key.
(3) Windows logo key	Displays the Windows Start menu.
(4) Spacebar	Turns the keyboard lights on and off when pressed in combination with the fn key (select models only).
(5) Windows applications key	Displays a shortcut menu for items beneath the pointer.
(6) Embedded numeric keypad keys	Can be used like the keys on an external numeric keypad.
(7) Function keys	Execute frequently used system functions when pressed in combination with the fn key.

Front components

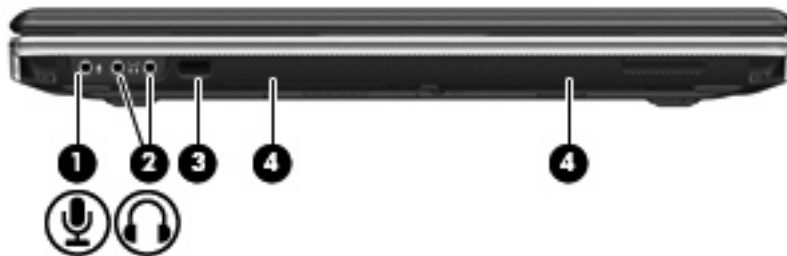

Component	Description
(1) Audio-in (microphone) jack	Connects an optional computer headset microphone, stereo array microphone, or monaural microphone.
(2) Audio-out (headphone) jacks (2)	Produce sound when connected to optional powered stereo speakers, headphones, ear buds, a headset, or television audio.
(3) Consumer infrared lens	Receives a signal from the HP Remote Control (provided with select models only).
(4) Speakers (2)	Produce sound.

Right-side components

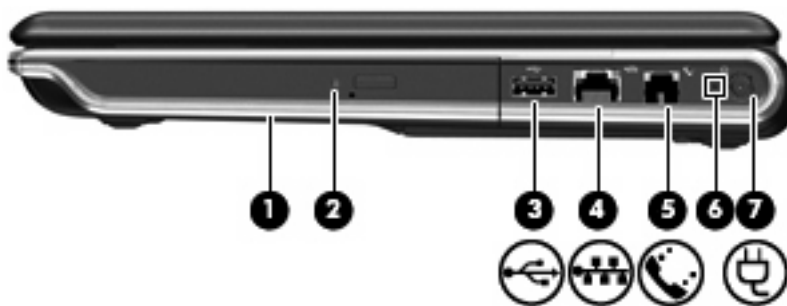

Component	Description
(1) Optical drive	Reads optical discs and, on select models, also writes to optical discs.
(2) Optical drive light	Blinking: The optical drive is being accessed.
(3) USB port	Connects an optional USB device.
(4) RJ-45 (network) jack	Connects a network cable.
(5) RJ-11 (modem) jack	Connects a modem cable.
(6) AC adapter light	<ul style="list-style-type: none"> On: The computer is connected to external power. Off: The computer is not connected to external power.
(7) Power connector	Connects an AC adapter.

Left-side components

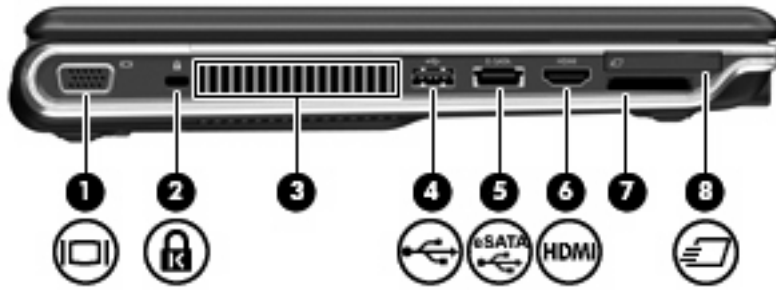

Component	Description
(1) External monitor port	Connects an external VGA monitor or projector.
(2) Security cable slot	Attaches an optional security cable to the computer. NOTE: The security cable is designed to act as a deterrent, but it may not prevent the computer from being mishandled or stolen.
(3) Vent	Enables airflow to cool internal components. NOTE: The computer fan starts up automatically to cool internal components and prevent overheating. It is normal for the internal fan to cycle on and off during routine operation.
(4) USB port	Connects an optional USB device.
(5) eSATA/USB port	Connects a high-performance eSATA component, such as an eSATA external hard drive, or connects an optional USB device.
(6) HDMI port (select models only)	Connects an optional video or audio device, such as a high-definition television, or any compatible digital or audio component. NOTE: Depending on your computer model, the computer may include an HDMI port or a USB port at this location.
(7) Digital Media Slot	Supports the following optional digital card formats: Secure Digital (SD) Memory Card, MultiMediaCard (MMC), Memory Stick (MS), Memory Stick Pro (MSP), xD-Picture Card (XD).
(8) ExpressCard slot	Supports an optional ExpressCard/34 module.

Bottom components

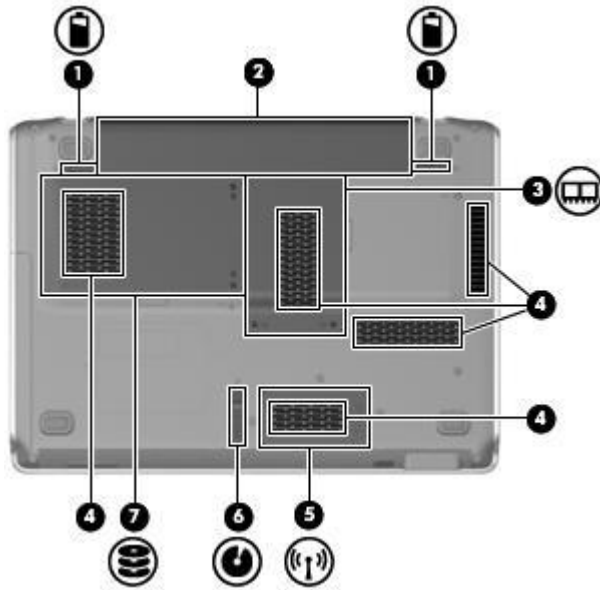

Component	Description
(1) Battery release latches (2)	Release the battery from the battery bay.
(2) Battery bay	Holds the battery.
(3) Memory module compartment	Contains the memory module slots.
(4) Vents (5)	Enable airflow to cool internal components.
	NOTE: The computer fan starts up automatically to cool internal components and prevent overheating. It is normal for the internal fan to cycle on and off during routine operation.
(5) Wireless module compartment	Holds a wireless LAN module.
	NOTE: To prevent an unresponsive system, replace the wireless module only with a wireless module authorized for use in the computer by the governmental agency that regulates wireless devices in your country or region. If you replace the module and then receive a warning message, remove the module to restore computer functionality, and then contact technical support through Help and Support.
(6) Optical drive release latch	Releases the optical drive.
(7) Hard drive bay	Holds the hard drive.

Display components



Component	Description
(1) Internal display switch	Turns off the display and initiates Sleep if the display is closed while the power is on.
(2) Internal microphones (2) (select models only)	Record sound. NOTE: If there is a microphone icon next to each microphone opening, your computer has internal microphones.
(3) Webcam light	On: The webcam is in use.
(4) Webcam	Records audio and video and captures still photographs.

Wireless antennae

On select computer models, at least 2 antennae send and receive signals from one or more wireless devices. These antennae are not visible from the outside of the computer.



 **NOTE:** For optimal transmission, keep the areas immediately around the antennae free from obstructions.

To see wireless regulatory notices, refer to the section of the *Regulatory, Safety and Environmental Notices* that applies to your country or region. These notices are located in Help and Support.

3 Illustrated parts catalog

Serial number location

When ordering parts or requesting information, provide the computer serial number and model number located on the bottom of the computer.

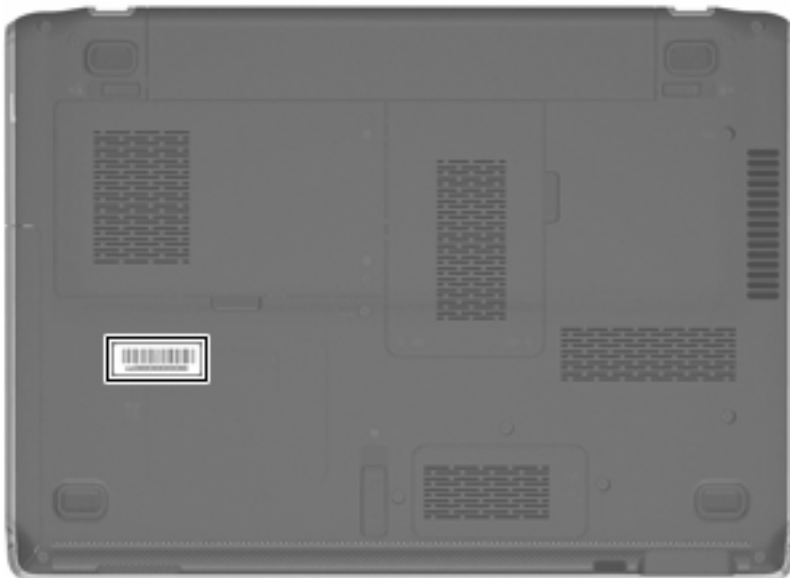

Computer major components

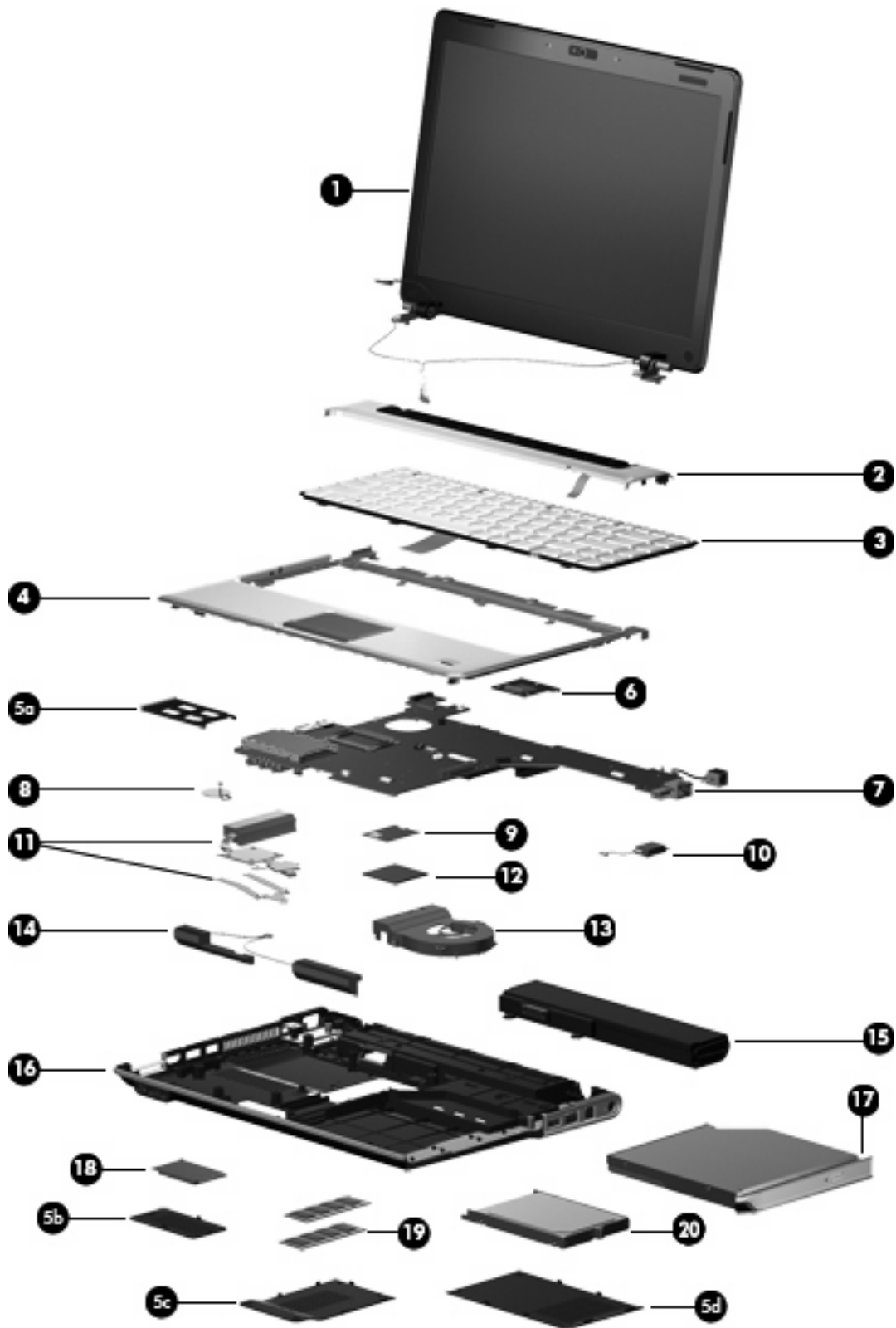

Item	Description	Spare part number
(1)	13.3-inch, WXGA BrightView display assembly (includes webcam/microphone module, webcam/microphone module cable, 2 microphones, and 3 wireless antenna transceivers and cables)	
	For use in dv3000 models	468806-001
	For use in dv3500 models with an LCD display	496107-001
	For use in dv3500 models with an LED display	496108-001
(2)	Switch cover (includes LED board and cable)	
	For use in dv3000 models	468820-001
	For use in dv3500 models	501012-001
(3)	Keyboard	
	For use in dv3000 models:	
	• Japan	468817-291
	• South Korea	468817-AD1
	• Taiwan	468817-AB1
	• Thailand	468817-281
	• The United States	468817-001
	For use in dv3500 models:	
	• Brazil	496121-201
	• France	496121-051
	• French Canada	496121-121
	• Germany	496121-041
	• Greece	496121-151
	• International	496121-B31
	• Italy	496121-061
	• Japan	496121-291
	• Korea	496121-AD1
	• Latin America	496121-161
	• Norway	496121-DH1
	• Portugal	496121-131
	• Russia	496121-251
	• Saudi Arabia	496121-171
	• Spain	496121-071
	• Switzerland	496121-111
	• Taiwan	496121-AB1
	• Thailand	496121-281

Item	Description	Spare part number
	<ul style="list-style-type: none"> Turkey 	496121-141
	<ul style="list-style-type: none"> United Kingdom 	496121-031
	<ul style="list-style-type: none"> United States 	496121-001
	<ul style="list-style-type: none"> United States, lighted keyboard 	496120-001
(4)	Top cover (includes TouchPad and cable, fingerprint reader board cable, and caps lock LED board and cable)	
	For use in dv3000 models	468819-001
	For use in dv3500 models	501011-001
	Plastics Kit (see Plastics Kit on page 26 for more information)	
	For use in dv3000 models	468821-001
	For use in dv3500 models	501013-001
(5a)	ExpressCard slot bezel	
(5b)	Wireless module compartment cover	
(5c)	Memory module compartment cover	
(5d)	Hard drive cover	
(6)	Fingerprint reader board (includes fingerprint reader board bracket, not illustrated)	
	For use only in dv3000 models	468831-001
	For use only in dv3500 models	502464-001
(7)	System board (includes replacement thermal material and power connector cable)	
	For use only in dv3000 models	468499-001
	For use only in dv3500 models	496097-001
(8)	RTC battery (includes double-sided tape)	468824-001
(9)	Modem module	
	NOTE: The modem module spare part kit does not include a modem module cable. The modem module cable is included in the Cable Kit, spare part number 468827-001 for dv3000 models, 502463-001 for dv3500 models.	
	For use in dv3000 models:	
	<ul style="list-style-type: none"> For use in all countries and regions except Australia and New Zealand 	468825-001
	<ul style="list-style-type: none"> For use only in Australia and New Zealand 	468825-011
	For use in dv3500 models:	
	<ul style="list-style-type: none"> For use in all countries and regions except Australia and New Zealand 	461749-001
	<ul style="list-style-type: none"> For use only in Australia and New Zealand 	461749-011
(10)	Bluetooth module (includes double-sided tape)	398393-002
	NOTE: The Bluetooth module spare part kit does not include a Bluetooth module cable. The Bluetooth module cable is included in the Cable Kit, spare part number 468827-001 for dv3000 models, 502463-001 for dv3500 models.	
(11)	Heat sink (includes heat sink retention clip and replacement thermal material)	

Item	Description	Spare part number
	For use in dv3000 models	468829-001
	For use in dv3500 models	501015-001
(12)	Processor (include replacement thermal material)	
	For use in dv3000 models:	
	<ul style="list-style-type: none"> Intel Core2 Duo T9500 2.60-GHz processor (6-MB L2 cache, 800-MHz FSB) 	459609-001
	<ul style="list-style-type: none"> Intel Core2 Duo T9300 2.50-GHz processor (6-MB L2 cache, 800-MHz FSB) 	459608-001
	<ul style="list-style-type: none"> Intel Core2 Duo T8300 2.40-GHz processor (3-MB L2 cache, 800-MHz FSB) 	459607-001
	<ul style="list-style-type: none"> Intel Core2 Duo T8100 2.10-GHz processor (3-MB L2 cache, 800-MHz FSB) 	459606-001
	<ul style="list-style-type: none"> Intel Core2 Duo T5850 2.16-GHz processor (2-MB L2 cache, 667-MHz FSB) 	482351-001
	<ul style="list-style-type: none"> Intel Core2 Duo T5550 1.83-GHz processor (2-MB L2 cache, 667-MHz FSB) 	458247-001
	<ul style="list-style-type: none"> Pentium Dual Core T2390 1.86-GHz processor (1-MB of L2 cache, 533-MHz FSB) 	492593-001
	For use in dv3500 models:	
	<ul style="list-style-type: none"> Intel Core2 Duo T9400 2.53-GHz processor (6-MB L2 cache, 1066-MHz FSB) 	496098-001
	<ul style="list-style-type: none"> Intel Core2 Duo P8600 2.40-GHz processor (3-MB L2 cache, 1066-MHz FSB) 	496099-001
	<ul style="list-style-type: none"> Intel Core2 Duo P8400 2.26-GHz processor (3-MB L2 cache, 1066-MHz FSB) 	496100-001
	<ul style="list-style-type: none"> Intel Core2 Duo T7350 2.00-GHz processor (3-MB L2 cache, 1066-MHz FSB) 	501017-001
	<ul style="list-style-type: none"> Intel Core2 Duo T5900 2.20-GHz processor (2-MB L2 cache, 800-MHz FSB) 	496103-001
	<ul style="list-style-type: none"> Intel Core2 Duo T5800 2.00-GHz processor (2-MB L2 cache, 800-MHz FSB) 	496102-001
	<ul style="list-style-type: none"> Intel Core2 Duo T3200 2.00-GHz processor (1-MB L2 cache, 800-MHz FSB) 	496104-001
(13)	Fan	468830-001
(14)	Speakers	468828-001
(15)	Battery	
	For use in dv3000 models:	
	<ul style="list-style-type: none"> 6-cell, 2.55-Ah, 55-Wh Li-ion 	468816-001
	<ul style="list-style-type: none"> 4-cell, 2.55-Ah, 37-Wh Li-ion 	468815-001
	For use in dv3500 models:	
	<ul style="list-style-type: none"> 6-cell, 2.55-Ah, 55-Wh Li-ion 	496119-001
	<ul style="list-style-type: none"> 4-cell, 2.55-Ah, 37-Wh Li-ion 	496118-001
(16)	Base enclosure (includes 4 base enclosure rubber feet)	
	For use in dv3000 models	468818-001
	For use in dv3500 models	501010-001
	Rubber Foot Kit (not illustrated, includes 4 base enclosure rubber feet)	
	For use in dv3000 models	468823-001
	For use in dv3500 models	502461-001

Item	Description	Spare part number
(17)	Optical drive (include bezel and bracket)	
	For use in dv3000 models:	
	<ul style="list-style-type: none"> DVD±RW and CD-RW Super Multi, Double-Layer Combo Drive 	468813-001
	<ul style="list-style-type: none"> DVD/CD-RW Combo Drive 	468812-001
	For use in dv3500 models:	
	<ul style="list-style-type: none"> DVD±RW and CD-RW Super Multi, Double-Layer Combo Drive 	496116-001
	<ul style="list-style-type: none"> DVD±RW and CD-RW Super Multi, Double-Layer Combo Drive with LightScribe 	496117-001
	Optical Drive Kit (not illustrated, includes bezel, bracket, and screws)	468814-001
(18)	WLAN module	
	Intel 4965 802.11a/b/g/n WLAN modules:	
	<ul style="list-style-type: none"> For use in Antigua and Barbuda, Argentina, Aruba, the Bahamas, Barbados, Bermuda, Brunei, Canada, the Cayman Islands, Chile, Colombia, Costa Rica, the Dominican Republic, Ecuador, El Salvador, Guam, Guatemala, Haiti, Honduras, Hong Kong, India, Indonesia, Malaysia, Mexico, Panama, Paraguay, Peru, Saudi Arabia, Taiwan, Uruguay, the United States, Venezuela, and Vietnam 	441086-001
	<ul style="list-style-type: none"> For use in Austria, Azerbaijan, Bahrain, Belgium, Brazil, Bulgaria, Croatia, Cyprus, the Czech Republic, Denmark, Egypt, Estonia, Finland, France, Georgia, Germany, Greece, Hungary, Iceland, Ireland, Israel, Italy, Latvia, Lebanon, Liechtenstein, Lithuania, Luxembourg, Malta, Monaco, the Netherlands, Norway, Oman, the Philippines, Poland, Portugal, Qatar, Romania, Russia, Serbia, Singapore, Slovakia, Slovenia, South Africa, Spain, Sri Lanka, Sweden, Switzerland, Turkey, Ukraine, the United Kingdom, and Uzbekistan 	441086-002
	<ul style="list-style-type: none"> For use in Australia, New Zealand, Pakistan, and the People's Republic of China 	441086-003
	<ul style="list-style-type: none"> For use in Japan 	441086-291
	<ul style="list-style-type: none"> For use in South Korea 	441086-AD1
	Intel 4965 802.11a/b/g WLAN modules:	
	<ul style="list-style-type: none"> For use in Antigua and Barbuda, Argentina, Aruba, the Bahamas, Barbados, Bermuda, Brunei, Canada, the Cayman Islands, Chile, Colombia, Costa Rica, the Dominican Republic, Ecuador, El Salvador, Guam, Guatemala, Haiti, Honduras, Hong Kong, India, Indonesia, Malaysia, Mexico, Panama, Paraguay, Peru, Saudi Arabia, Taiwan, Uruguay, the United States, Venezuela, and Vietnam 	441082-001
	<ul style="list-style-type: none"> For use in Austria, Azerbaijan, Bahrain, Belgium, Brazil, Bulgaria, Croatia, Cyprus, the Czech Republic, Denmark, Egypt, Estonia, Finland, France, Georgia, Germany, Greece, Hungary, Iceland, Ireland, Israel, Italy, Latvia, Lebanon, Liechtenstein, Lithuania, Luxembourg, Malta, Monaco, the Netherlands, Norway, Oman, the Philippines, Poland, Portugal, Qatar, Romania, Russia, Serbia, Singapore, Slovakia, Slovenia, South Africa, Spain, Sri Lanka, Sweden, Switzerland, Turkey, Ukraine, the United Kingdom, and Uzbekistan 	441082-002
	<ul style="list-style-type: none"> For use in Australia, New Zealand, Pakistan, and the People's Republic of China 	441082-003
	<ul style="list-style-type: none"> For use in Japan 	441082-291
	Intel 3945 802.11a/b/g WLAN modules:	
	<ul style="list-style-type: none"> For use in Antigua and Barbuda, Argentina, Aruba, the Bahamas, Barbados, Bermuda, Brunei, Canada, the Cayman Islands, Chile, Colombia, Costa Rica, the Dominican Republic, Ecuador, El Salvador, Guam, Guatemala, Haiti, Honduras, 	451861-001

Item	Description	Spare part number
	Hong Kong, India, Indonesia, Malaysia, Mexico, Panama, Paraguay, Peru, Saudi Arabia, Taiwan, Uruguay, the United States, Venezuela, and Vietnam	
	<ul style="list-style-type: none"> For use in Austria, Azerbaijan, Bahrain, Belgium, Brazil, Bulgaria, Croatia, Cyprus, the Czech Republic, Denmark, Egypt, Estonia, Finland, France, Georgia, Germany, Greece, Hungary, Iceland, Ireland, Israel, Italy, Latvia, Lebanon, Liechtenstein, Lithuania, Luxembourg, Malta, Monaco, the Netherlands, Norway, Oman, the Philippines, Poland, Portugal, Qatar, Romania, Russia, Serbia, Singapore, Slovakia, Slovenia, South Africa, Spain, Sri Lanka, Sweden, Switzerland, Turkey, Ukraine, the United Kingdom, and Uzbekistan 	451861-002
	<ul style="list-style-type: none"> For use in Australia, New Zealand, Pakistan, and the People's Republic of China 	451861-003
	<ul style="list-style-type: none"> For use in Japan 	451861-291
	Intel WiFi Link 5100 802.11a/b/g/n WLAN module for use in all countries and regions	480985-001
	Intel WiFi Link 5100 802.11a/b/g WLAN module for use in all countries and regions	482957-001
(19)	Memory module	
	For use in dv3000 models:	
	<ul style="list-style-type: none"> 2048-MB (PC2-5300, 667-MHz, DDR2) 	448151-003
	<ul style="list-style-type: none"> 1024-MB (PC2-5300, 667-MHz, DDR2) 	448150-002
	<ul style="list-style-type: none"> 512-MB (PC2-5300, 667-MHz, DDR2) 	452312-002
	For use in dv3500 models:	
	<ul style="list-style-type: none"> 4096-MB (PC2-6400, 667-MHz, DDR2) 	496112-001
	<ul style="list-style-type: none"> 2048-MB (PC2-6400, 667-MHz, DDR2) 	496111-001
	<ul style="list-style-type: none"> 1024-MB (PC2-6400, 667-MHz, DDR2) 	496110-001
(20)	Hard drive (includes bracket)	
	For use in dv3000 models:	
	<ul style="list-style-type: none"> 320-GB, 5400-rpm 	468810-001
	<ul style="list-style-type: none"> 250-GB, 5400-rpm 	468809-001
	<ul style="list-style-type: none"> 160-GB, 5400-rpm 	468808-001
	<ul style="list-style-type: none"> 120-GB, 5400-rpm 	468807-001
	For use in dv3500 models:	
	<ul style="list-style-type: none"> 500-GB, 5400-rpm 	497761-001
	<ul style="list-style-type: none"> 400-GB, 5400-rpm 	497760-001
	<ul style="list-style-type: none"> 320-GB, 5400-rpm 	496115-001
	<ul style="list-style-type: none"> 250-GB, 5400-rpm 	496114-001
	<ul style="list-style-type: none"> 160-GB, 5400-rpm 	496113-001
	Hard Drive Kit (not illustrated, includes hard drive bracket and screws)	468811-001

Display assembly components

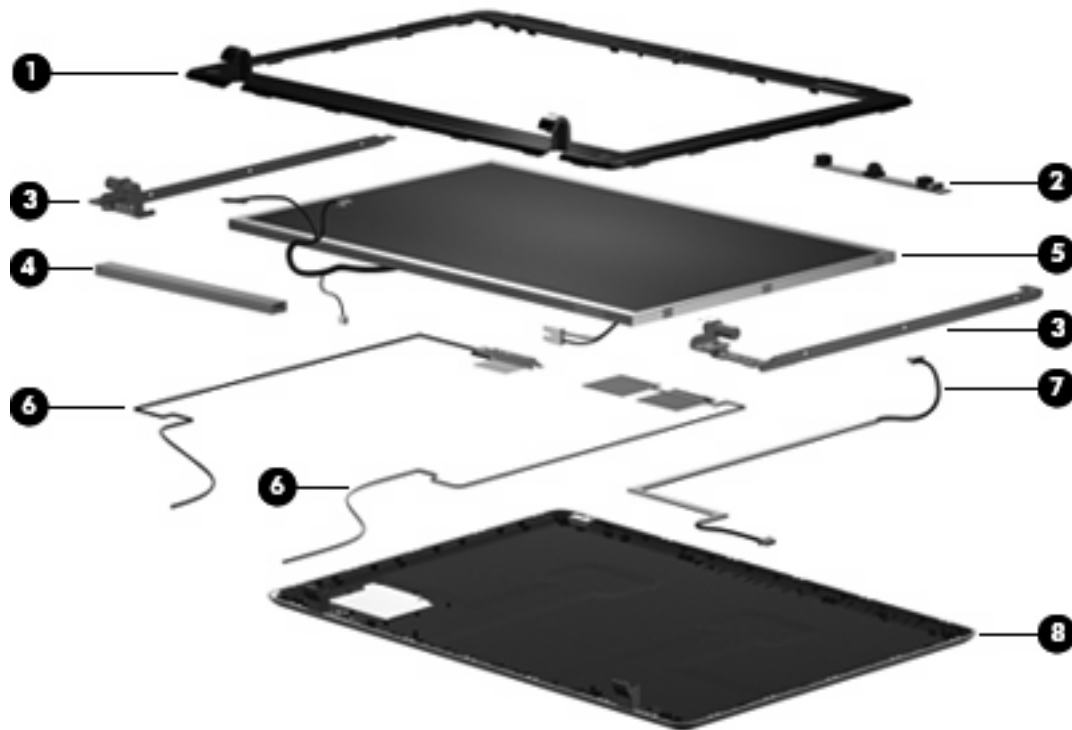

Item	Description	Spare part number
(1)	Display bezel	
	For use with dv3000 models	468797-001
	For use with dv3500 models with an LCD display	500953-001
	For use with dv3500 models with an LED display	500954-001
(2)	Webcam/microphone module	
	For use with dv3000 models	468804-001
	For use with dv3500 models	500967-001
(3)	Display Hinge Kit (includes left and right display hinges)	
	For use with dv3000 models	468799-001
	For use with dv3500 models with an LCD display	500959-001
	For use with dv3500 models with an LED display	500960-001
(4)	Display inverter (includes Mylar shield)	
	For use in dv3000 models	468798-001
	For use in dv3500 models	500957-001
(5)	13.3-inch, WXGA BrightView display panel (includes display panel cable)	
	For use in dv3000 models	468796-001
	For use in dv3500 model with an LCD display	496105-001

Item	Description	Spare part number
	For use in dv3500 models with an LED display	496106-001
(6)	Display Cable Kit (includes 3 wireless antenna transceivers and cables and display panel cable)	
	For use in dv3000 models	468800-001
	For use in dv3500 models with an LCD display	500961-001
	For use in dv3500 models with an LED display	500962-001
(7)	Webcam/microphone module cable	468805-001
(8)	Display enclosure	
	For use in dv3000 models	468801-001
	For use in dv3500 models with an LCD display	500955-001
	For use in dv3500 models with an LED display	500956-001
	Display Rubber Kit (not illustrated; includes display bezel screw covers and display bezel bumper pads)	
	For use in dv3000 models	468802-001
	For use in dv3500 models with an LCD display	500966-001
	For use in dv3500 models with an LED display	502460-001
	Display Screw Kit (not illustrated)	
	For use in dv3000 models	468803-001
	For use in dv3500 models with an LCD display	500958-001
	For use in dv3500 models with an LED display	502364-001

Plastics Kit

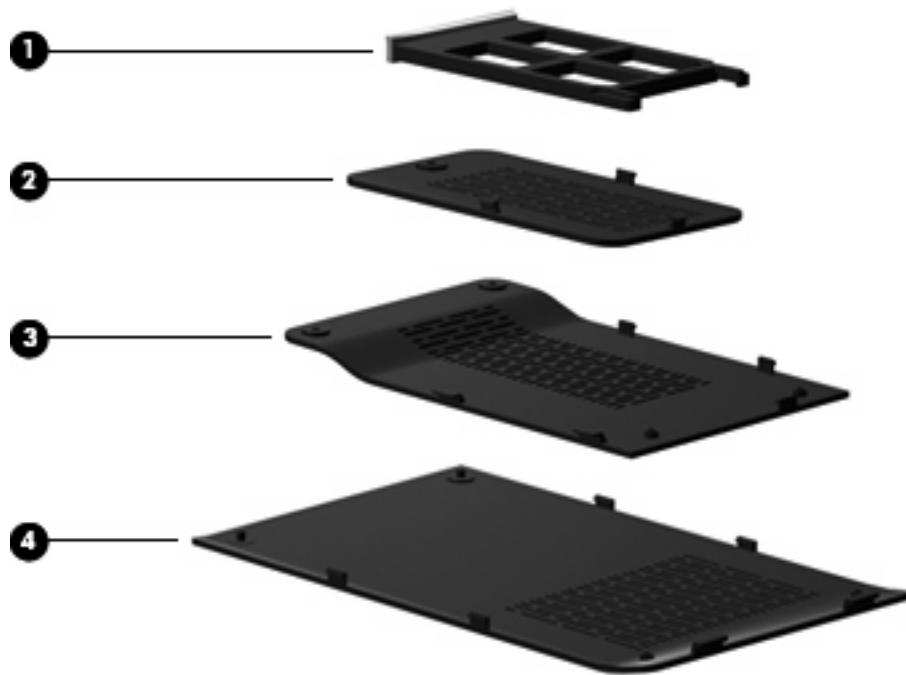

Item	Description	Spare part number
Plastics Kit		
	For use in dv3000 models	468821-001
	For use in dv3500 models	501013-001
(1)	ExpressCard slot bezel	
(2)	Wireless module compartment cover (includes 1 captive screw, secured by a C-clip)	
(3)	Memory module compartment cover (includes 2 captive screws, secured by C-clips)	
(4)	Hard drive bay cover (includes 2 captive screws, secured by C-clips)	

Mass storage devices



Item	Description	Spare part number
(1)	Hard drive (includes bracket)	
	For use in dv3000 models:	
	<ul style="list-style-type: none"> 320-GB, 5400-rpm 	468810-001
	<ul style="list-style-type: none"> 250-GB, 5400-rpm 	468809-001
	<ul style="list-style-type: none"> 160-GB, 5400-rpm 	468808-001
	<ul style="list-style-type: none"> 120-GB, 5400-rpm 	468807-001
	For use in dv3500 models:	
	<ul style="list-style-type: none"> 500-GB, 5400-rpm 	497761-001
	<ul style="list-style-type: none"> 400-GB, 5400-rpm 	497760-001
	<ul style="list-style-type: none"> 320-GB, 5400-rpm 	496115-001
	<ul style="list-style-type: none"> 250-GB, 5400-rpm 	496114-001
	<ul style="list-style-type: none"> 160-GB, 5400-rpm 	496113-001
	Hard Drive Kit (not illustrated, includes hard drive bracket and screws)	468811-001
(2)	Optical drive (includes bezel and bracket)	
	For use in dv3000 models:	
	<ul style="list-style-type: none"> DVD±RW and CD-RW Super Multi, Double-Layer Combo Drive 	468813-001
	<ul style="list-style-type: none"> DVD/CD-RW Combo Drive 	468812-001
	For use in dv3500 models:	
	<ul style="list-style-type: none"> DVD±RW and CD-RW Super Multi, Double-Layer Combo Drive 	496116-001

Item	Description	Spare part number
	<ul style="list-style-type: none"> DVD±RW and CD-RW Super Multi, Double-Layer Combo Drive with LightScribe 	496117-001
	Optical Drive Kit (not illustrated, includes bezel, bracket, and screws)	468814-001

Miscellaneous parts

Description	Spare part number
90-W HP Smart AC Adapter	463955-001
Remote control (fits inside ExpressCard slot)	465539-001
Power cord:	
For use in dv3000 models:	
<ul style="list-style-type: none"> For use in Australia and New Zealand 	383496-011
<ul style="list-style-type: none"> For use in India 	383496-D61
<ul style="list-style-type: none"> For use in Japan 	383496-291
<ul style="list-style-type: none"> For use in the People's Republic of China 	383496-AA1
<ul style="list-style-type: none"> For use in South Korea 	383496-AD1
<ul style="list-style-type: none"> For use in Taiwan 	383496-AB1
<ul style="list-style-type: none"> For use in the United Kingdom 	383496-031
<ul style="list-style-type: none"> For use in the United States 	383496-001
For use in dv3500 models:	
<ul style="list-style-type: none"> For use in Argentina 	490371-D01
<ul style="list-style-type: none"> For use in Australia and New Zealand 	490371-011
<ul style="list-style-type: none"> For use in Brazil 	490371-201
<ul style="list-style-type: none"> For use in Denmark 	490371-081
<ul style="list-style-type: none"> For use in Europe 	490371-021
<ul style="list-style-type: none"> For use in India 	490371-D61
<ul style="list-style-type: none"> For use in Italy 	490371-061
<ul style="list-style-type: none"> For use in Japan 	490371-291
<ul style="list-style-type: none"> For use in the People's Republic of China 	490371-AA1
<ul style="list-style-type: none"> For use in the South Africa 	490371-AR1
<ul style="list-style-type: none"> For use in South Korea 	490371-AD1
<ul style="list-style-type: none"> For use in Switzerland 	490371-111
<ul style="list-style-type: none"> For use in Taiwan 	490371-AB1
<ul style="list-style-type: none"> For use in the United Kingdom 	490371-031
<ul style="list-style-type: none"> For use in the United Kingdom 	490371-001

Description	Spare part number
Screw Kit	
For use in dv3000 models	468822-001
For use in dv3500 models	502462-001
<ul style="list-style-type: none"> <li data-bbox="277 371 564 394">• Phillips PM3.0×4.0 screw <li data-bbox="277 420 651 443">• Phillips PM2.5×11.0 captive screw <li data-bbox="277 468 564 491">• Phillips PM2.5×7.0 screw <li data-bbox="277 516 639 539">• Phillips PM2.5×6.0 captive screw <li data-bbox="277 564 564 588">• Phillips PM2.5×5.0 screw <li data-bbox="277 613 624 636">• Black Phillips PM2.5×4.0 screw <li data-bbox="277 661 624 684">• Silver Phillips PM2.5×4.0 screw <li data-bbox="277 709 639 732">• Phillips PM2.0×5.0 captive screw <li data-bbox="277 758 564 781">• Phillips PM2.0×4.0 screw <li data-bbox="277 806 639 829">• Phillips PM2.0×2.0 captive screw 	

Sequential part number listing

Spare part number	Description
383496-001	Power cord for use in dv3000 models in the United States
383496-011	Power cord for use in dv3000 models in Australia and New Zealand
383496-031	Power cord for use in dv3000 models in the United Kingdom
383496-291	Power cord for use in dv3000 models in Japan
383496-AA1	Power cord for use in dv3000 models in the People's Republic of China
383496-AB1	Power cord for use in dv3000 models in Taiwan
383496-AD1	Power cord for use in dv3000 models in South Korea
383496-D61	Power cord for use in dv3000 models in India
398393-002	Bluetooth module (includes double-sided tape) NOTE: The Bluetooth module spare part kit does not include a Bluetooth module cable. The Bluetooth module cable is included in the Cable Kit, spare part number 468827-001 for dv3000 models, 502463-001 for dv3500 models.
441082-001	Intel 4965 802.11a/b/g WLAN module for use in Antigua and Barbuda, Argentina, Aruba, the Bahamas, Barbados, Bermuda, Brunei, Canada, the Cayman Islands, Chile, Colombia, Costa Rica, the Dominican Republic, Ecuador, El Salvador, Guam, Guatemala, Haiti, Honduras, Hong Kong, India, Indonesia, Malaysia, Mexico, Panama, Paraguay, Peru, Saudi Arabia, Taiwan, Uruguay, the United States, Venezuela, and Vietnam
441082-002	Intel 4965 802.11a/b/g WLAN module for use in Austria, Azerbaijan, Bahrain, Belgium, Brazil, Bulgaria, Croatia, Cyprus, the Czech Republic, Denmark, Egypt, Estonia, Finland, France, Georgia, Germany, Greece, Hungary, Iceland, Ireland, Israel, Italy, Latvia, Lebanon, Liechtenstein, Lithuania, Luxembourg, Malta, Monaco, the Netherlands, Norway, Oman, the Philippines, Poland, Portugal, Qatar, Romania, Russia, Serbia, Singapore, Slovakia, Slovenia, South Africa, Spain, Sri Lanka, Sweden, Switzerland, Turkey, Ukraine, the United Kingdom, and Uzbekistan
441082-003	Intel 4965 802.11a/b/g WLAN module for use in Australia, New Zealand, Pakistan, and the People's Republic of China
441082-291	Intel 4965 802.11a/b/g WLAN module for use in Japan
441086-001	Intel 4965 802.11a/b/g/n WLAN module for use in Antigua and Barbuda, Argentina, Aruba, the Bahamas, Barbados, Bermuda, Brunei, Canada, the Cayman Islands, Chile, Colombia, Costa Rica, the Dominican Republic, Ecuador, El Salvador, Guam, Guatemala, Haiti, Honduras, Hong Kong, India, Indonesia, Malaysia, Mexico, Panama, Paraguay, Peru, Saudi Arabia, Taiwan, Uruguay, the United States, Venezuela, and Vietnam
441086-002	Intel 4965 802.11a/b/g/n WLAN module for use in Austria, Azerbaijan, Bahrain, Belgium, Brazil, Bulgaria, Croatia, Cyprus, the Czech Republic, Denmark, Egypt, Estonia, Finland, France, Georgia, Germany, Greece, Hungary, Iceland, Ireland, Israel, Italy, Latvia, Lebanon, Liechtenstein, Lithuania, Luxembourg, Malta, Monaco, the Netherlands, Norway, Oman, the Philippines, Poland, Portugal, Qatar, Romania, Russia, Serbia, Singapore, Slovakia, Slovenia, South Africa, Spain, Sri Lanka, Sweden, Switzerland, Turkey, Ukraine, the United Kingdom, and Uzbekistan
441086-003	Intel 4965 802.11a/b/g/n WLAN module for use in Australia, New Zealand, Pakistan, and the People's Republic of China
441086-291	Intel 4965 802.11a/b/g/n WLAN module for use in Japan
441086-AD1	Intel 4965 802.11a/b/g/n WLAN module for use in South Korea
448150-002	1024-MB memory module for use in dv3000 models (PC2-5300, 667-GHz)

Spare part number	Description
448151-003	2048-MB memory module for use in dv3000 models (PC2-5300, 667-GHz)
451861-001	Intel 3945 802.11a/b/g WLAN module for use in Antigua and Barbuda, Argentina, Aruba, the Bahamas, Barbados, Bermuda, Brunei, Canada, the Cayman Islands, Chile, Colombia, Costa Rica, the Dominican Republic, Ecuador, El Salvador, Guam, Guatemala, Haiti, Honduras, Hong Kong, India, Indonesia, Malaysia, Mexico, Panama, Paraguay, Peru, Saudi Arabia, Taiwan, Uruguay, the United States, Venezuela, and Vietnam
451861-002	Intel 3945 802.11a/b/g WLAN module for use in Austria, Azerbaijan, Bahrain, Belgium, Brazil, Bulgaria, Croatia, Cyprus, the Czech Republic, Denmark, Egypt, Estonia, Finland, France, Georgia, Germany, Greece, Hungary, Iceland, Ireland, Israel, Italy, Latvia, Lebanon, Liechtenstein, Lithuania, Luxembourg, Malta, Monaco, the Netherlands, Norway, Oman, the Philippines, Poland, Portugal, Qatar, Romania, Russia, Serbia, Singapore, Slovakia, Slovenia, South Africa, Spain, Sri Lanka, Sweden, Switzerland, Turkey, Ukraine, the United Kingdom, and Uzbekistan
451861-003	Intel 3945 802.11a/b/g WLAN module for use in Australia, New Zealand, Pakistan, and the People's Republic of China
451861-291	Intel 3945 802.11a/b/g WLAN module for use in Japan
452312-002	512-MB memory module for use in dv3000 models (PC2-5300, 667-GHz)
458247-001	Intel Core2 Duo T5550 1.83-GHz processor for use in dv3000 models (2-MB of L2 cache, 667-MHz FSB)
459606-001	Intel Core2 Duo T8100 2.10-GHz processor for use in dv3000 models (3-MB L2 cache, 800-MHz FSB)
459607-001	Intel Core2 Duo T8300 2.40-GHz processor for use in dv3000 models (3-MB L2 cache, 800-MHz FSB)
459608-001	Intel Core2 Duo T9300 2.50-GHz processor for use in dv3000 models (6-MB L2 cache, 800-MHz FSB)
459609-001	Intel Core2 Duo T9500 2.60-GHz processor for use in dv3000 models (6-MB L2 cache, 800-MHz FSB)
461749-001	Modem module for use in dv3500 models in all countries and regions except Australia and New Zealand
461749-011	Modem module for use in dv3500 models only in Australia and New Zealand
463955-001	90-W HP Smart AC Adapter for use in dv3000 models
465539-001	Remote control (fits inside ExpressCard slot)
468499-001	System board for use only in dv3000 models (includes replacement thermal material and power connector cable)
468796-001	13.3-inch, WXGA BrightView display panel for use in dv3000 models (includes display panel cable)
468797-001	Display bezel for use on dv3000 models
468798-001	Display inverter for use in dv3000 models (includes Mylar shield)
468799-001	Display Hinge Kit for use in dv3000 models (includes left and right display hinges)
468800-001	Display Cable Kit for use in dv3000 models (includes display panel cable and 3 wireless antenna transceivers and cables)
468801-001	Display enclosure for use in dv3000 models
468802-001	Display Rubber Kit for use in dv3000 models (includes display bezel screw covers and display bezel bumper pads)
468803-001	Display Screw Kit for use in dv3000 models
468804-001	Webcam/microphone module for use in dv3000 models
468805-001	Webcam/microphone module cable

Spare part number	Description
468806-001	13.3-inch, WXGA BrightView display assembly for use in dv3000 models (includes webcam/microphone module, webcam/microphone module cable, 2 microphones, and 3 wireless antenna transceivers and cables)
468807-001	120-GB, 5400-rpm hard drive for use in dv3000 models (includes bracket)
468808-001	160-GB, 5400-rpm hard drive for use in dv3000 models (includes bracket)
468809-001	250-GB, 5400-rpm hard drive for use in dv3000 models (includes bracket)
468810-001	320-GB, 5400-rpm hard drive for use in dv3000 models (includes bracket)
468811-001	Hard Drive Kit (includes hard drive bracket and screws)
468812-001	DVD/CD-RW Combo Drive for use in dv3000 models
468813-001	DVD±RW and CD-RW Super Multi, Double-Layer Combo Drive for use in dv3000 models
468814-001	Optical Drive Kit (includes bezel, bracket, and screws)
468815-001	4-cell, 2.55-Ah, 37-Wh Li-ion battery for use in dv3000 models
468816-001	6-cell, 2.55-Ah, 55-Wh Li-ion battery for use in dv3000 models
468817-001	Keyboard for use in dv3000 models in the United States
468817-281	Keyboard for use in dv3000 models in Thailand
468817-291	Keyboard for use in dv3000 models in Japan
468817-AB1	Keyboard for use in dv3000 models in Taiwan
468817-AD1	Keyboard for use in dv3000 models in South Korea
468818-001	Base enclosure for use in dv3000 models (includes 4 base enclosure rubber feet)
468819-001	Top cover for use in dv3000 models (includes TouchPad and cable, fingerprint reader board cable, and caps lock LED board and cable)
468820-001	Switch cover for use in dv3000 models (includes LED board and cable)
468821-001	Plastics Kit for use in dv3000 models (see Plastics Kit on page 26 for more information)
468822-001	Screw Kit for use in dv3000 models
468823-001	Rubber Foot Kit for use in dv3000 models (includes 4 base enclosure rubber feet)
468824-001	RTC battery (includes double-sided tape)
468825-001	Modem module for use in dv3000 models in all countries and regions except Australia and New Zealand NOTE: The modem module spare part kit does not include a modem module cable. The modem module cable is included in the Cable Kit, spare part number 468827-001 for dv3000 models, 502463-001 for dv3500 models.
468825-011	Modem module for use in dv3000 models only in Australia and New Zealand NOTE: The modem module spare part kit does not include a modem module cable. The modem module cable is included in the Cable Kit, spare part number 468827-001 for dv3000 models, 502463-001 for dv3500 models.
468827-001	Cable Kit for use in dv3000 models (includes a Bluetooth module cable and a modem module cable)
468828-001	Speakers
468829-001	Heat sink for use in dv3000 models (includes heat sink retention clip and replacement thermal material)

Spare part number	Description
468830-001	Fan
468831-001	Fingerprint reader board for use in dv3000 models (includes fingerprint reader board bracket)
480985-001	Intel WiFi Link 5100 802.11a/b/g/n WLAN module for use in all countries and regions
481567-001	Display Miscellaneous Kit
482351-001	Intel Core2 Duo T5850 2.16-GHz processor for use in dv3000 models (2-MB of L2 cache, 667-MHz FSB)
482957-001	Intel WiFi Link 5100 802.11a/b/g WLAN module for use in all countries and regions
486548-001	ExpressCard slot cover for use in dv3500 models
490371-001	Power cord for use in dv3500 models in the United States
490371-011	Power cord for use in dv3500 models in Australia and New Zealand
490371-021	Power cord for use in dv3500 models in Europe
490371-031	Power cord for use in dv3500 models in the United Kingdom
490371-061	Power cord for use in dv3500 models in Italy
490371-081	Power cord for use in dv3500 models in Denmark
490371-111	Power cord for use in dv3500 models in Switzerland
490371-201	Power cord for use in dv3500 models in Brazil
490371-291	Power cord for use in dv3500 models in Japan
490371-AA1	Power cord for use in dv3500 models in the People's Republic of China
490371-AB1	Power cord for use in dv3500 models in Taiwan
490371-AD1	Power cord for use in dv3500 models in South Korea
490371-AR1	Power cord for use in dv3500 models in South Africa
490371-D01	Power cord for use in dv3500 models in Argentina
490371-D61	Power cord for use in dv3500 models in India
492593-001	Pentium Dual Core T2390 1.86-GHz processor for use in dv3000 models (1-MB of L2 cache, 533-MHz FSB)
496097-001	System board for use only in dv3500 models (includes replacement thermal material and power connector cable)
496098-001	Intel Core2 Duo T9400 2.53-GHz processor (6-MB L2 cache, 1066-MHz FSB) for use in dv3500 models
496099-001	Intel Core2 Duo P8600 2.40-GHz processor (3-MB L2 cache, 1066-MHz FSB) for use in dv3500 models
496100-001	Intel Core2 Duo P8400 2.26-GHz processor (3-MB L2 cache, 1066-MHz FSB) for use in dv3500 models
496103-001	Intel Core2 Duo T5900 2.20-GHz processor (2-MB L2 cache, 800-MHz FSB) for use in dv3500 models
496102-001	Intel Core2 Duo T5800 2.00-GHz processor (2-MB L2 cache, 800-MHz FSB) for use in dv3500 models
496104-001	Intel Core2 Duo T3200 2.00-GHz processor (1-MB L2 cache, 800-MHz FSB) for use in dv3500 models
496105-001	13.3-inch, WXGA BrightView display panel for use in dv3500 models with an LCD display (includes display panel cable)

Spare part number	Description
496106-001	13.3-inch, WXGA BrightView display panel for use in dv3500 models with an LED display (includes display panel cable)
496107-001	13.3-inch, WXGA BrightView display assembly for use in dv3500 models with an LCD display (includes webcam/microphone module, webcam/microphone module cable, 2 microphones, and 3 wireless antenna transceivers and cables)
496108-001	13.3-inch, WXGA BrightView display assembly for use in dv3500 models with an LED display (includes webcam/microphone module, webcam/microphone module cable, 2 microphones, and 3 wireless antenna transceivers and cables)
496110-001	1024-MB memory module (PC2-6400, 667-GHz) for use in dv3500 models
496111-001	2048-MB memory module (PC2-6400, 667-GHz) for use in dv3500 models
496112-001	4096-MB memory module (PC2-6400, 667-GHz) for use in dv3500 models
496113-001	160-GB, 5400-rpm hard drive for use in dv3500 models (includes bracket)
496114-001	250-GB, 5400-rpm hard drive for use in dv3500 models (includes bracket)
496115-001	320-GB, 5400-rpm hard drive for use in dv3500 models (includes bracket)
496116-001	DVD±RW and CD-RW Super Multi, Double-Layer Combo Drive for use in dv3500 models
496117-001	DVD±RW and CD-RW Super Multi, Double-Layer Combo Drive with LightScribe for use in dv3500 models
496118-001	4-cell, 2.55-Ah, 37-Wh Li-ion battery for use in dv3500 models
496119-001	6-cell, 2.55-Ah, 55-Wh Li-ion battery for use in dv3500 models
496120-001	Lighted keyboard for use with dv3500 models in the United States
496121-001	Keyboard for use with dv3500 models in the United States
496121-031	Keyboard for use with dv3500 models in the United Kingdom
496121-041	Keyboard for use with dv3500 models in Germany
496121-051	Keyboard for use with dv3500 models in France
496121-061	Keyboard for use with dv3500 models in Italy
496121-071	Keyboard for use with dv3500 models in Spain
496121-111	Keyboard for use with dv3500 models in Switzerland
496121-121	Keyboard for use with dv3500 models in French Canada
496121-131	Keyboard for use with dv3500 models in Portugal
496121-141	Keyboard for use with dv3500 models in Turkey
496121-151	Keyboard for use with dv3500 models in Greece
496121-161	Keyboard for use with dv3500 models in Latin America
496121-171	Keyboard for use with dv3500 models in Saudi Arabia
496121-201	Keyboard for use with dv3500 models in Brazil
496121-251	Keyboard for use with dv3500 models in Russia
496121-281	Keyboard for use with dv3500 models in Thailand
496121-291	Keyboard for use with dv3500 models in Japan

Spare part number	Description
496121-AB1	Keyboard for use with dv3500 models in Taiwan
496121-AD1	Keyboard for use with dv3500 models in South Korea
496121-B31	Keyboard for use with dv3500 models Internationally
496121-DH1	Keyboard for use with dv3500 models in Norway
497760-001	400-GB, 5400-rpm hard drive for use in dv3500 models (includes bracket)
497761-001	500-GB, 5400-rpm hard drive for use in dv3500 models (includes bracket)
500953-001	Display bezel for use on dv3500 models with an LCD display
500954-001	Display bezel for use on dv3500 models with an LED display
500955-001	Display enclosure for use in dv3500 models with an LCD display
500956-001	Display enclosure for use in dv3500 models with an LED display
500957-001	Display inverter for use in dv3500 models (includes Mylar shield)
500958-001	Display Screw Kit for use in dv3500 models with an LCD display
500959-001	Display Hinge Kit for use in dv3500 models with an LCD display (includes left and right display hinges)
500960-001	Display Hinge Kit for use in dv3500 models with an LED display (includes left and right display hinges)
500961-001	Display Cable Kit for use in dv3500 models with an LCD display (includes display panel cable and 3 wireless antenna transceivers and cables)
500962-001	Display Cable Kit for use in dv3500 models with an LED display (includes display panel cable and 3 wireless antenna transceivers and cables)
500966-001	Display Rubber Kit for use in dv3500 models with an LCD display (includes display bezel screw covers and display bezel bumper pads)
500967-001	Webcam/microphone module for use in dv3500 models
501010-001	Base enclosure for use in dv3500 models (includes 4 base enclosure rubber feet)
501011-001	Top cover for use in dv3500 models (includes TouchPad and cable, fingerprint reader board cable, and caps lock LED board and cable)
501012-001	Switch cover for use in dv3500 models (includes LED board and cable)
501013-001	Plastics Kit for use in dv3500 models (see Plastics Kit on page 26 for more information)
501015-001	Heat sink for use in dv3500 models (includes heat sink retention clip and replacement thermal material)
501017-001	Intel Core2 Duo T7350 2.00-GHz processor (3-MB L2 cache, 1066-MHz FSB) for use in dv3500 models
502364-001	Display Screw Kit for use in dv3500 models with an LED display
502460-001	Display Rubber Kit for use in dv3500 models with an LED display (includes display bezel screw covers and display bezel bumper pads)
502461-001	Rubber Foot Kit for use in dv3500 models (includes 4 base enclosure rubber feet)
502462-001	Screw Kit for use in dv3500 models
502463-001	Cable Kit for use in dv3500 models (includes a Bluetooth module cable and a modem module cable)
502464-001	Fingerprint reader board for use in dv3500 models (includes fingerprint reader board bracket)

4 Removal and replacement procedures

Preliminary replacement requirements

Tools required

You will need the following tools to complete the removal and replacement procedures:

- Flat-bladed screwdriver
- Magnetic screwdriver
- Phillips P0 and P1 screwdrivers

Service considerations

The following sections include some of the considerations that you must keep in mind during disassembly and assembly procedures.

 **NOTE:** As you remove each subassembly from the computer, place the subassembly (and all accompanying screws) away from the work area to prevent damage.

Plastic parts

 **CAUTION:** Using excessive force during disassembly and reassembly can damage plastic parts. Use care when handling the plastic parts. Apply pressure only at the points designated in the maintenance instructions.

Cables and connectors

-
- △ **CAUTION:** When servicing the computer, be sure that cables are placed in their proper locations during the reassembly process. Improper cable placement can damage the computer.
-

Cables must be handled with extreme care to avoid damage. Apply only the tension required to unseat or seat the cables during removal and insertion. Handle cables by the connector whenever possible. In all cases, avoid bending, twisting, or tearing cables. Be sure that cables are routed in such a way that they cannot be caught or snagged by parts being removed or replaced. Handle flex cables with extreme care; these cables tear easily.

Drive handling

-
- △ **CAUTION:** Drives are fragile components that must be handled with care. To prevent damage to the computer, damage to a drive, or loss of information, observe these precautions:
-

Before removing or inserting a hard drive, shut down the computer. If you are unsure whether the computer is off or in Hibernation, turn the computer on, and then shut it down through the operating system.

Before handling a drive, be sure that you are discharged of static electricity. While handling a drive, avoid touching the connector.

Before removing a diskette drive or optical drive, be sure that a diskette or disc is not in the drive and be sure that the optical drive tray is closed.

Handle drives on surfaces covered with at least one inch of shock-proof foam.

Avoid dropping drives from any height onto any surface.

After removing a hard drive, an optical drive, or a diskette drive, place it in a static-proof bag.

Avoid exposing a hard drive to products that have magnetic fields, such as monitors or speakers.

Avoid exposing a drive to temperature extremes or liquids.

If a drive must be mailed, place the drive in a bubble pack mailer or other suitable form of protective packaging and label the package "FRAGILE."

Grounding guidelines

Electrostatic discharge damage

Electronic components are sensitive to electrostatic discharge (ESD). Circuitry design and structure determine the degree of sensitivity. Networks built into many integrated circuits provide some protection, but in many cases, ESD contains enough power to alter device parameters or melt silicon junctions.

A discharge of static electricity from a finger or other conductor can destroy static-sensitive devices or microcircuitry. Even if the spark is neither felt nor heard, damage may have occurred.

An electronic device exposed to ESD may not be affected at all and can work perfectly throughout a normal cycle. Or the device may function normally for a while, then degrade in the internal layers, reducing its life expectancy.

- △ **CAUTION:** To prevent damage to the computer when you are removing or installing internal components, observe these precautions:

Keep components in their electrostatic-safe containers until you are ready to install them.

Use nonmagnetic tools.

Before touching an electronic component, discharge static electricity by using the guidelines described in this section.

Avoid touching pins, leads, and circuitry. Handle electronic components as little as possible.

If you remove a component, place it in an electrostatic-safe container.

The following table shows how humidity affects the electrostatic voltage levels generated by different activities.

- △ **CAUTION:** A product can be degraded by as little as 700 V.

Typical electrostatic voltage levels			
Event	Relative humidity		
	10%	40%	55%
Walking across carpet	35,000 V	15,000 V	7,500 V
Walking across vinyl floor	12,000 V	5,000 V	3,000 V
Motions of bench worker	6,000 V	800 V	400 V
Removing DIPS from plastic tube	2,000 V	700 V	400 V
Removing DIPS from vinyl tray	11,500 V	4,000 V	2,000 V
Removing DIPS from Styrofoam	14,500 V	5,000 V	3,500 V
Removing bubble pack from PCB	26,500 V	20,000 V	7,000 V
Packing PCBs in foam-lined box	21,000 V	11,000 V	5,000 V

Packaging and transporting guidelines

Follow these grounding guidelines when packaging and transporting equipment:

- To avoid hand contact, transport products in static-safe tubes, bags, or boxes.
- Protect ESD-sensitive parts and assemblies with conductive or approved containers or packaging.
- Keep ESD-sensitive parts in their containers until the parts arrive at static-free workstations.
- Place items on a grounded surface before removing items from their containers.
- Always be properly grounded when touching a component or assembly.
- Store reusable ESD-sensitive parts from assemblies in protective packaging or nonconductive foam.
- Use transporters and conveyors made of antistatic belts and roller bushings. Be sure that mechanized equipment used for moving materials is wired to ground and that proper materials are selected to avoid static charging. When grounding is not possible, use an ionizer to dissipate electric charges.

Workstation guidelines

Follow these grounding workstation guidelines:

- Cover the workstation with approved static-shielding material.
- Use a wrist strap connected to a properly grounded work surface and use properly grounded tools and equipment.
- Use conductive field service tools, such as cutters, screwdrivers, and vacuums.
- When fixtures must directly contact dissipative surfaces, use fixtures made only of static-safe materials.
- Keep the work area free of nonconductive materials, such as ordinary plastic assembly aids and Styrofoam.
- Handle ESD-sensitive components, parts, and assemblies by the case or PCM laminate. Handle these items only at static-free workstations.
- Avoid contact with pins, leads, or circuitry.
- Turn off power and input signals before inserting or removing connectors or test equipment.

Equipment guidelines

Grounding equipment must include either a wrist strap or a foot strap at a grounded workstation.

- When seated, wear a wrist strap connected to a grounded system. Wrist straps are flexible straps with a minimum of one megohm $\pm 10\%$ resistance in the ground cords. To provide proper ground, wear a strap snugly against the skin at all times. On grounded mats with banana-plug connectors, use alligator clips to connect a wrist strap.
- When standing, use foot straps and a grounded floor mat. Foot straps (heel, toe, or boot straps) can be used at standing workstations and are compatible with most types of shoes or boots. On conductive floors or dissipative floor mats, use foot straps on both feet with a minimum of one megohm resistance between the operator and ground. To be effective, the conductive strips must be worn in contact with the skin.

The following grounding equipment is recommended to prevent electrostatic damage:

- Antistatic tape
- Antistatic smocks, aprons, and sleeve protectors
- Conductive bins and other assembly or soldering aids
- Nonconductive foam
- Conductive tabletop workstations with ground cords of one megohm resistance
- Static-dissipative tables or floor mats with hard ties to the ground
- Field service kits
- Static awareness labels
- Material-handling packages
- Nonconductive plastic bags, tubes, or boxes
- Metal tote boxes
- Electrostatic voltage levels and protective materials

The following table lists the shielding protection provided by antistatic bags and floor mats.

Material	Use	Voltage protection level
Antistatic plastic	Bags	1,500 V
Carbon-loaded plastic	Floor mats	7,500 V
Metallized laminate	Floor mats	5,000 V

Unknown user password

If the computer you are servicing has an unknown user password, follow these steps to clear the password.



NOTE: These steps also clear CMOS.

Before disassembling the computer, follow these steps:

1. Shut down the computer. If you are unsure whether the computer is off or in Hibernation, turn the computer on, and then shut it down through the operating system.
2. Disconnect all external devices connected to the computer.
3. Disconnect the power from the computer by first unplugging the power cord from the AC outlet and then unplugging the AC adapter from the computer.
4. Remove the battery (see [Battery on page 43](#)).
5. Remove the RTC battery (see [RTC battery on page 77](#)).
6. Wait approximately 5 minutes.
7. Replace the RTC battery and reassemble the computer.
8. Connect AC power to the computer. Do not reinsert any batteries at this time.
9. Turn on the computer.

All passwords and all CMOS settings have been cleared.

Component replacement procedures

This chapter provides removal and replacement procedures.

There are as many as 69 screws, in 10 different sizes, that must be removed, replaced, or loosened when servicing the computer. Make special note of each screw size and location during removal and replacement.

Serial number

Report the computer serial number to HP when requesting information or ordering spare parts. The serial number is located on the bottom of the computer.

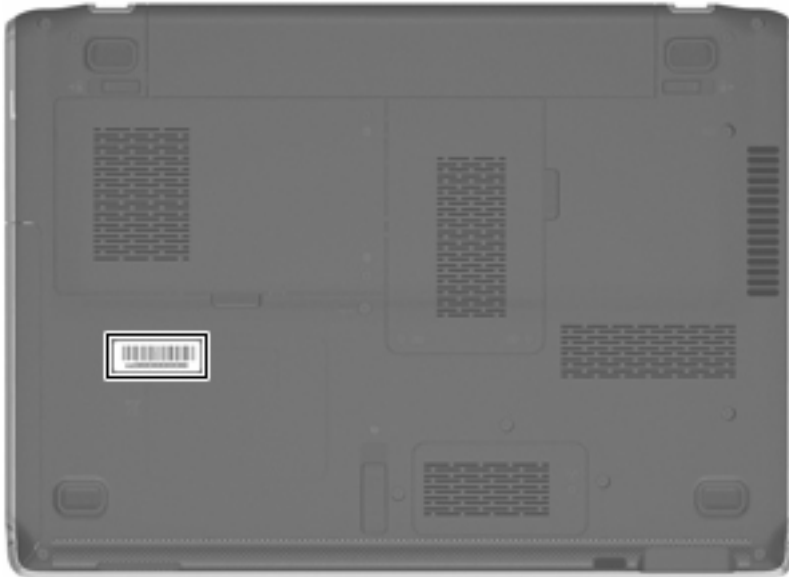

Computer feet

Description	Spare part number
Rubber Foot Kit for use in dv3000 models (includes 4 base enclosure rubber feet)	468823-001
Rubber Foot Kit for use in dv3500 models (includes 4 base enclosure rubber feet)	502461-001

The computer feet are adhesive-backed rubber pads. The feet attach to the base enclosure in the locations illustrated below.

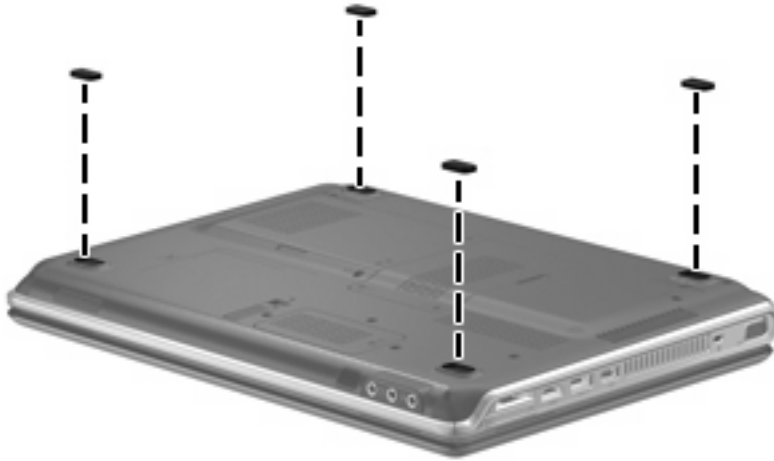

Battery

Description	Spare part number
For use in dv3000 models:	
6-cell, 2.55-Ah, 55-Wh Li-ion	468816-001
4-cell, 2.55-Ah, 37-Wh Li-ion	468815-001
For use in dv3500 models:	
6-cell, 2.55-Ah, 55-Wh Li-ion	496119-001
4-cell, 2.55-Ah, 37-Wh Li-ion	496118-001

Before disassembling the computer, follow these steps

1. Shut down the computer. If you are unsure whether the computer is off or in Hibernation, turn the computer on, and then shut it down through the operating system.
2. Disconnect all external devices connected to the computer.
3. Disconnect the power from the computer by first unplugging the power cord from the AC outlet and then unplugging the AC adapter from the computer.

Remove the battery:

1. Turn the computer upside down on a flat surface with the battery bay toward you.
2. Slide and release the left battery release latch (1).

 **NOTE:** The left battery release latch automatically returns to its original position.

3. Slide the right battery release latch (2) to release the battery from the battery bay.
4. Remove the battery (3).

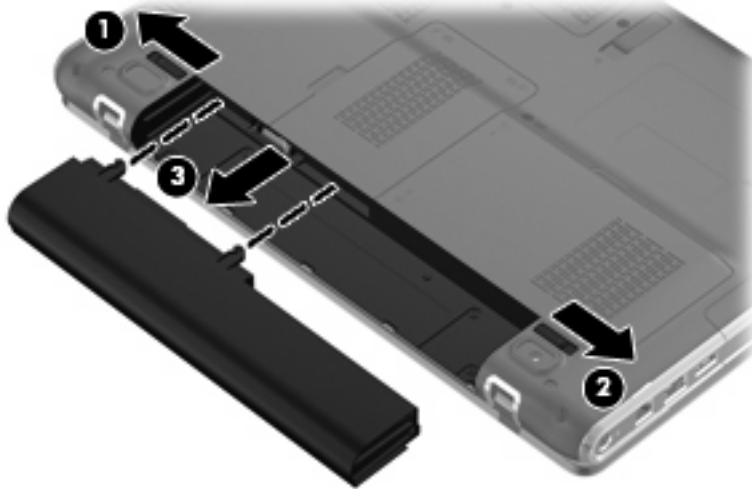

To insert the battery, insert the rear edge of the battery (1) into the battery bay and slide it forward until the battery is seated. Lock the battery into the battery bay by sliding the right battery release latch (2) to the left. The left battery release latch automatically locks the battery into place.

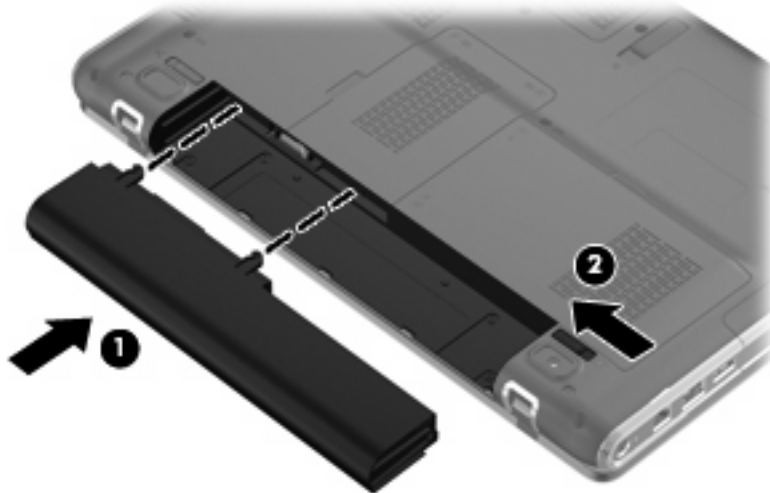

WLAN module

Description	Spare part number
Intel 4965 802.11a/b/g/n WLAN modules:	
<ul style="list-style-type: none"> For use in Antigua and Barbuda, Argentina, Aruba, the Bahamas, Barbados, Bermuda, Brunei, Canada, the Cayman Islands, Chile, Colombia, Costa Rica, the Dominican Republic, Ecuador, El Salvador, Guam, Guatemala, Haiti, Honduras, Hong Kong, India, Indonesia, Malaysia, Mexico, Panama, Paraguay, Peru, Saudi Arabia, Taiwan, Uruguay, the United States, Venezuela, and Vietnam 	441086-001
<ul style="list-style-type: none"> For use in Austria, Azerbaijan, Bahrain, Belgium, Brazil, Bulgaria, Croatia, Cyprus, the Czech Republic, Denmark, Egypt, Estonia, Finland, France, Georgia, Germany, Greece, Hungary, Iceland, Ireland, Israel, Italy, Latvia, Lebanon, Liechtenstein, Lithuania, Luxembourg, Malta, Monaco, the Netherlands, Norway, Oman, the Philippines, Poland, Portugal, Qatar, Romania, Russia, Serbia, Singapore, Slovakia, Slovenia, South Africa, Spain, Sri Lanka, Sweden, Switzerland, Turkey, Ukraine, the United Kingdom, and Uzbekistan 	441086-002
<ul style="list-style-type: none"> For use in Australia, New Zealand, Pakistan, and the People's Republic of China 	441086-003
<ul style="list-style-type: none"> For use in Japan 	441086-291
<ul style="list-style-type: none"> For use in South Korea 	441086-AD1
Intel 4965 802.11a/b/g WLAN modules:	
<ul style="list-style-type: none"> For use in Antigua and Barbuda, Argentina, Aruba, the Bahamas, Barbados, Bermuda, Brunei, Canada, the Cayman Islands, Chile, Colombia, Costa Rica, the Dominican Republic, Ecuador, El Salvador, Guam, Guatemala, Haiti, Honduras, Hong Kong, India, Indonesia, Malaysia, Mexico, Panama, Paraguay, Peru, Saudi Arabia, Taiwan, Uruguay, the United States, Venezuela, and Vietnam 	441082-001
<ul style="list-style-type: none"> For use in Austria, Azerbaijan, Bahrain, Belgium, Brazil, Bulgaria, Croatia, Cyprus, the Czech Republic, Denmark, Egypt, Estonia, Finland, France, Georgia, Germany, Greece, Hungary, Iceland, Ireland, Israel, Italy, Latvia, Lebanon, Liechtenstein, Lithuania, Luxembourg, Malta, Monaco, the Netherlands, Norway, Oman, the Philippines, Poland, Portugal, Qatar, Romania, Russia, Serbia, Singapore, Slovakia, Slovenia, South Africa, Spain, Sri Lanka, Sweden, Switzerland, Turkey, Ukraine, the United Kingdom, and Uzbekistan 	441082-002
<ul style="list-style-type: none"> For use in Australia, New Zealand, Pakistan, and the People's Republic of China 	441082-003
<ul style="list-style-type: none"> For use in Japan 	441082-291
Intel 3945 802.11a/b/g WLAN modules:	
<ul style="list-style-type: none"> For use in Antigua and Barbuda, Argentina, Aruba, the Bahamas, Barbados, Bermuda, Brunei, Canada, the Cayman Islands, Chile, Colombia, Costa Rica, the Dominican Republic, Ecuador, El Salvador, Guam, Guatemala, Haiti, Honduras, Hong Kong, India, Indonesia, Malaysia, Mexico, Panama, Paraguay, Peru, Saudi Arabia, Taiwan, Uruguay, the United States, Venezuela, and Vietnam 	451861-001
<ul style="list-style-type: none"> For use in Austria, Azerbaijan, Bahrain, Belgium, Brazil, Bulgaria, Croatia, Cyprus, the Czech Republic, Denmark, Egypt, Estonia, Finland, France, Georgia, Germany, Greece, Hungary, Iceland, Ireland, Israel, Italy, Latvia, Lebanon, Liechtenstein, Lithuania, Luxembourg, Malta, Monaco, the Netherlands, Norway, Oman, the Philippines, Poland, Portugal, Qatar, Romania, Russia, Serbia, Singapore, Slovakia, Slovenia, South Africa, Spain, Sri Lanka, Sweden, Switzerland, Turkey, Ukraine, the United Kingdom, and Uzbekistan 	451861-002
<ul style="list-style-type: none"> For use in Australia, New Zealand, Pakistan, and the People's Republic of China 	451861-003
<ul style="list-style-type: none"> For use in Japan 	451861-291
Intel WiFi Link 5100 802.11a/b/g/n WLAN module for use in all countries and regions	480985-001
Intel WiFi Link 5100 802.11a/b/g WLAN module for use in all countries and regions	482957-001

Before removing the WLAN module, follow these steps:

1. Shut down the computer. If you are unsure whether the computer is off or in Hibernation, turn the computer on, and then shut it down through the operating system.
2. Disconnect all external devices connected to the computer.
3. Disconnect the power from the computer by first unplugging the power cord from the AC outlet and then unplugging the AC adapter from the computer.
4. Remove the battery (see [Battery on page 43](#)).

Remove the WLAN module:

 **NOTE:** To prevent an unresponsive system, replace the wireless module only with a wireless module authorized for use in the computer by the governmental agency that regulates wireless devices in your country or region. If you replace the module and then receive a warning message, remove the module to restore computer functionality, and then contact technical support through Help and Support.

1. Loosen the Phillips PM2.5×6.0 captive screw (1) that secures the wireless module compartment cover to the computer.
2. Lift the left side of the cover (2), swing it up and to the right, and remove the cover. The wireless module compartment cover is included in the Plastics Kit, spare part number 468821-001 for dv3000 models, 501013-001 for dv3500 models.

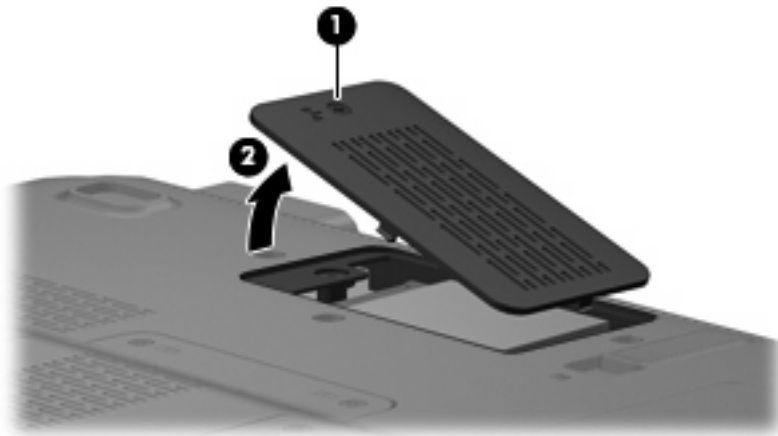

3. Disconnect the two WLAN antenna cables (1) from the WLAN module.

 **NOTE:** The black WLAN antenna cable is connected to the WLAN module “Main” terminal. The white WLAN antenna cable is connected to the WLAN module “Aux” terminal.

NOTE: Computer models equipped with an 802.11ab/g/n WLAN module will have an additional wireless antenna cable (2), yellow in color.

4. Remove the two Phillips PM2.5×4.0 screws (3) that secure the WLAN module to the computer. (The edge of the module opposite the slot rises away from the computer.)

5. Remove the WLAN module (4) by pulling it away from the slot at an angle.

 **NOTE:** WLAN modules are designed with a notch (5) to prevent incorrect installation into the WLAN module slot.

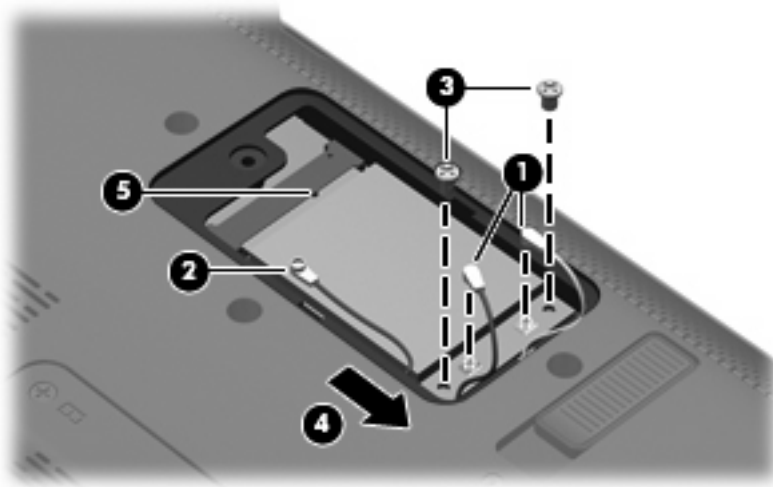

Reverse this procedure to install a WLAN module.

Optical drive

 **NOTE:** All optical drive spare part kits include an optical drive bezel.

Description	Spare part number
For use in dv3000 models:	
DVD±RW and CD-RW Super Multi Double-Layer Combo Drive	468813-001
DVD/CD-RW Combo Drive	468812-001
For use in dv3500 models:	
DVD±RW and CD-RW Super Multi Double-Layer Combo Drive	496116-001
DVD±RW and CD-RW Super Multi Double-Layer Combo Drive with LightScribe	496117-001

Before removing the optical drive, follow these steps:

1. Shut down the computer. If you are unsure whether the computer is off or in Hibernation, turn the computer on, and then shut it down through the operating system.
2. Disconnect all external devices connected to the computer.
3. Disconnect the power from the computer by first unplugging the power cord from the AC outlet and then unplugging the AC adapter from the computer.
4. Remove the battery (see [Battery on page 43](#)).

Remove the optical drive:

1. Slide the optical drive release latch **(1)** to release the optical drive from the computer.
2. Remove the optical drive **(2)** by sliding it out of the optical drive bay.

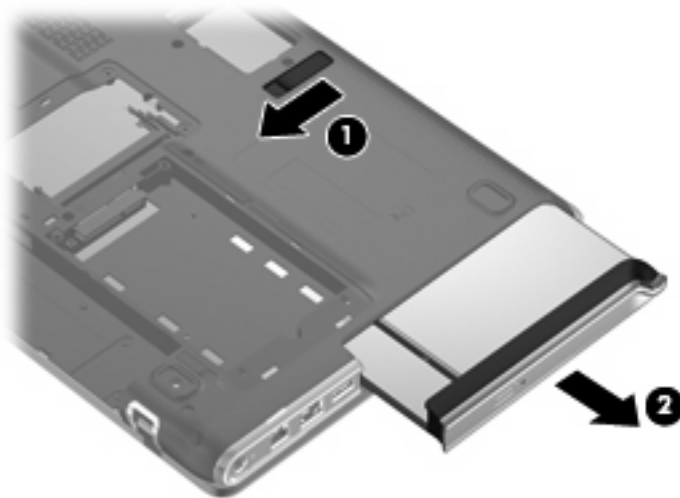

To insert the optical drive, insert the rear edge of the optical drive into the optical drive bay and slide it in until the optical drive is seated. The optical drive release latch automatically locks the optical drive into place.

Memory module

Description	Spare part number
For use in dv3000 computer models:	
2048-MB (667-MHz, PC2-5300, DDR2)	448151-003
1024-MB (667-MHz, PC2-5300, DDR2)	448150-002
512-MB (667-MHz, PC2-5300, DDR2)	452312-002
For use in dv3500 computer models:	
4096-MB (667-MHz, PC2-6400, DDR2)	496112-001
2048-MB (667-MHz, PC2-6400, DDR2)	496111-001
1024-MB (667-MHz, PC2-6400, DDR2)	496110-001

Before removing the memory module, follow these steps:

1. Shut down the computer. If you are unsure whether the computer is off or in Hibernation, turn the computer on, and then shut it down through the operating system.
2. Disconnect all external devices connected to the computer.
3. Disconnect the power from the computer by first unplugging the power cord from the AC outlet and then unplugging the AC adapter from the computer.
4. Remove the battery (see [Battery on page 43](#)).

Remove the memory module:

1. Loosen the two Phillips PM2.5×6.0 captive screws **(1)** that secure the memory module compartment cover to the computer.
2. Lift the rear edge of the cover **(2)**, swing it up and forward, and remove the cover. The memory module compartment cover is included in the Plastics Kit, spare part number 468821-001 for dv3000 models, 501013-001 for dv3500 models.

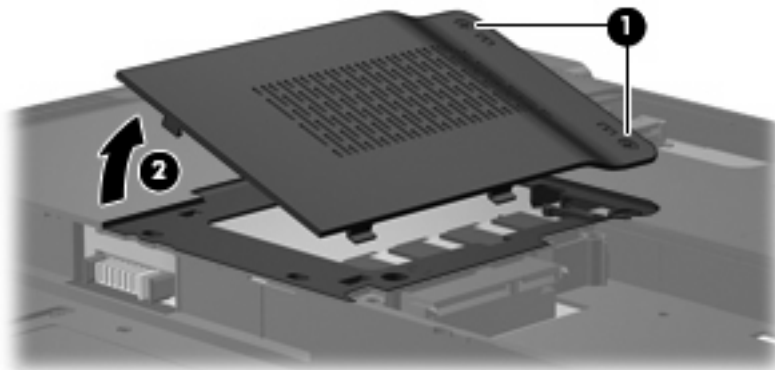

3. Spread the retaining tabs **(1)** on each side of the memory module slot to release the memory module. (The edge of the module opposite the slot rises away from the computer.)

4. Remove the module (2) by pulling it away from the slot at an angle.

 **NOTE:** Memory modules are designed with a notch (3) to prevent incorrect installation into the memory module slot.

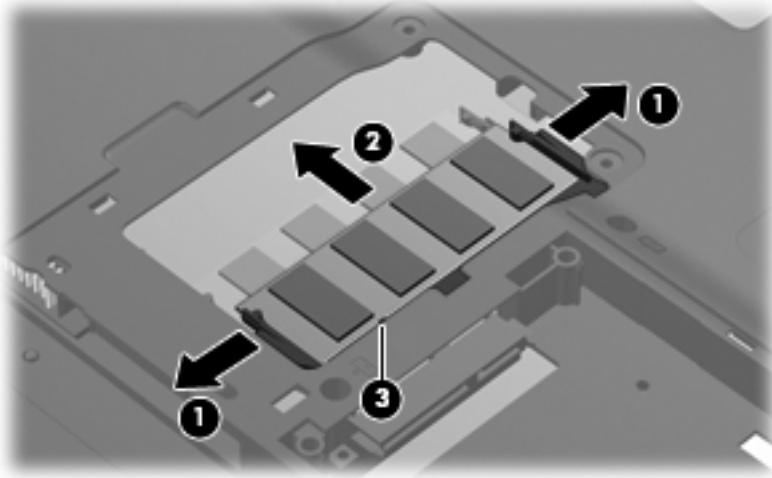

Reverse this procedure to install a memory module.

Hard drive

 **NOTE:** All hard drive spare part kits include a hard drive bracket.

Description	Spare part number
For use in dv3000 models:	
320-GB, 5400-rpm	468810-001
250-GB, 5400-rpm	468809-001
160-GB, 5400-rpm	468808-001
120-GB, 5400-rpm	468807-001
For use in dv3500 models:	
500-GB, 5400-rpm	497761-001
400-GB, 5400-rpm	497760-001
320-GB, 5400-rpm	496115-001
250-GB, 5400-rpm	496114-001
160-GB, 5400-rpm	496113-001
Hard Drive Kit (includes hard drive bracket and screws)	468811-001

Before removing the hard drive, follow these steps:

1. Shut down the computer. If you are unsure whether the computer is off or in Hibernation, turn the computer on, and then shut it down through the operating system.
2. Disconnect all external devices connected to the computer.
3. Disconnect the power from the computer by first unplugging the power cord from the AC outlet and then unplugging the AC adapter from the computer.
4. Remove the battery (see [Battery on page 43](#)).

Remove the hard drive:

1. Loosen the two Phillips PM2.5×6.0 captive screws (1) that secure the hard drive bay cover to the computer.

2. Lift the left side of the hard drive bay cover (2), swing it up and to the right, and remove the cover. The hard drive bay cover is included in the Plastics Kit, spare part number 468821-001 for dv3000 models, 501013-001 for dv3500 models.

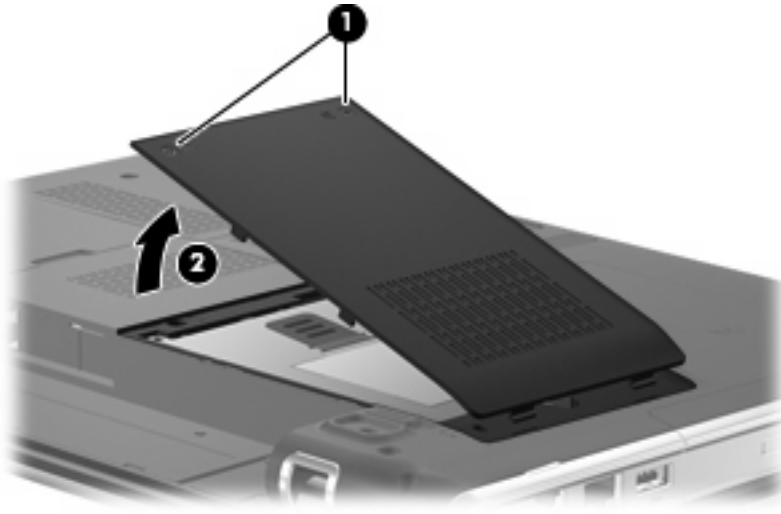

3. Loosen the Phillips PM2.5×11.0 captive screw (1) that secures the hard drive to the computer.
4. Use the Mylar tab (2) to slide the hard drive (3) to the right until it disconnects from the system board.
5. Remove the hard drive (4) from the hard drive bay.

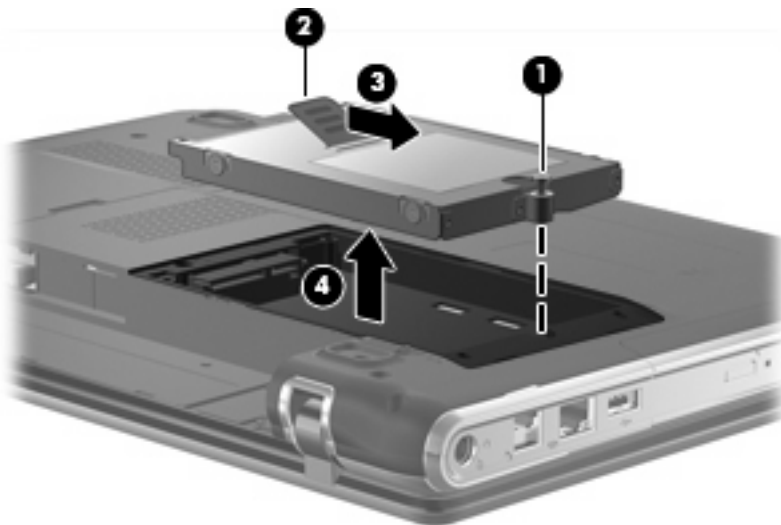

6. Remove the hard drive from the hard drive bay.
7. If it is necessary to replace the hard drive bracket, remove the four Phillips PM3.0×4.0 screws (1) that secure the hard drive bracket to the hard drive.

8. Lift the bracket (2) straight up to remove it from the hard drive.

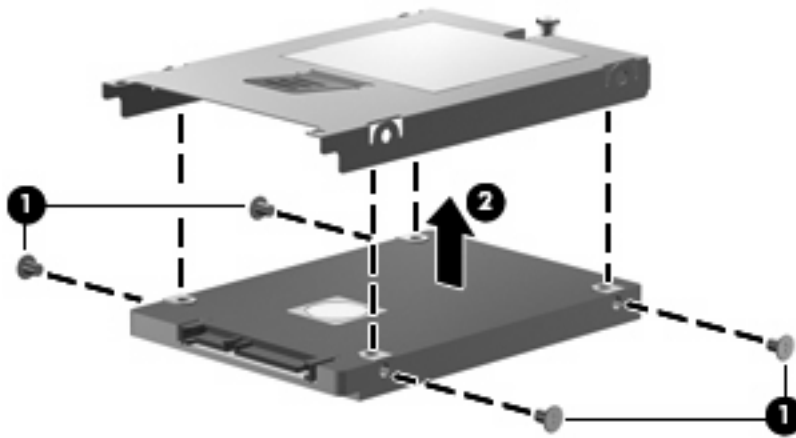

Reverse this procedure to reassemble and install the hard drive.

Keyboard

For use in:	Spare part number	For use in:	Spare part number
For use in dv3000 models:			
Japan	468817-291	Thailand	468817-281
South Korea	468817-AD1	The United States	468817-001
Taiwan	468817-AB1		
For use in dv3500 models:			
Brazil	496121-201	Russia	496121-251
France	496121-051	Saudi Arabia	496121-171
French Canada	496121-121	South Korea	496121-AD1
Germany	496121-041	Spain	496121-071
Greece	496121-151	Switzerland	496121-111
International	496121-B31	Taiwan	496121-AB1
Italy	496121-061	Thailand	496121-281
Japan	496121-291	Turkey	496121-141
Latin America	496121-161	United Kingdom	496121-031
Norway	496121-DH1	United States	496121-001
Portugal	496121-131	United States, lighted keyboard	496120-001

Before removing the keyboard, follow these steps:

1. Shut down the computer. If you are unsure whether the computer is off or in Hibernation, turn the computer on, and then shut it down through the operating system.
2. Disconnect all external devices connected to the computer.
3. Disconnect the power from the computer by first unplugging the power cord from the AC outlet and then unplugging the AC adapter from the computer.
4. Remove the battery (see [Battery on page 43](#)).
5. Remove the hard drive (see [Hard drive on page 51](#)).

Remove the keyboard:

1. Remove the four Phillips PM2.5×7.0 screws that secure the keyboard to the computer.

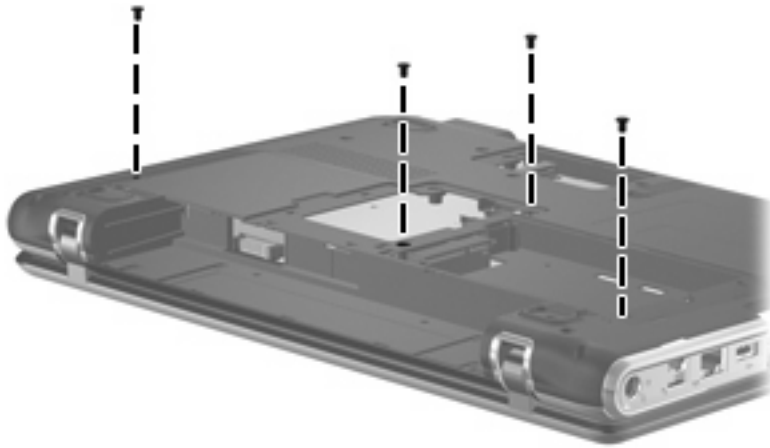

2. Turn the computer right-side up, with the front toward you.
3. Open the computer as far as possible.
4. Lift the rear edge of the keyboard (1) until it rests at an angle.
5. Release the keyboard (2) by sliding it back until it rests on the display assembly.



6. Release the zero insertion force (ZIF) connector to which the keyboard cable (1) is attached and disconnect the cable (2) from the system board.

 **NOTE:** If you are removing a lighted keyboard, you must disconnect an additional power cable from the system board.

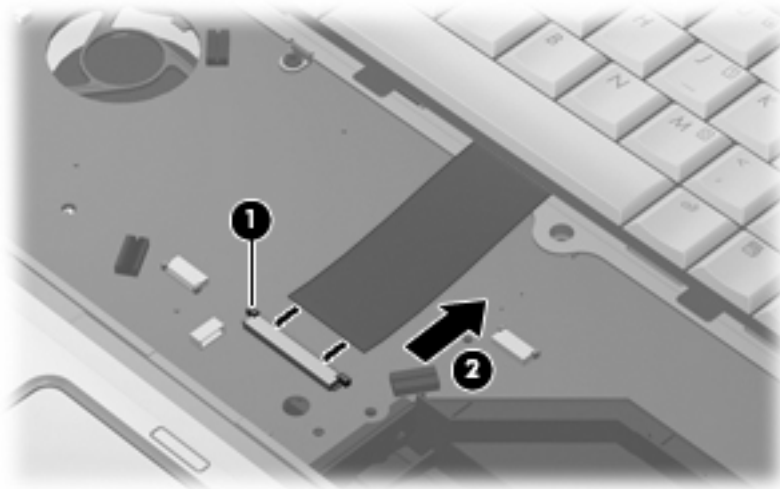

7. Remove the keyboard.

Reverse this procedure to install the keyboard.

Switch cover

Description	Spare part number
Switch cover for use in dv3000 models (includes LED board and cable)	468820-001
Switch cover for use in dv3500 models (includes LED board and cable)	501012-001

Before removing the switch cover, follow these steps:

1. Shut down the computer. If you are unsure whether the computer is off or in Hibernation, turn the computer on, and then shut it down through the operating system.
2. Disconnect all external devices connected to the computer.
3. Disconnect the power from the computer by first unplugging the power cord from the AC outlet and then unplugging the AC adapter from the computer.
4. Remove the battery (see [Battery on page 43](#)).
5. Remove the keyboard (see [Keyboard on page 54](#)).

Remove the switch cover:

1. Close the computer.
2. Turn the computer upside down, with the rear panel toward you.
3. Remove the two Phillips PM2.5×7.0 screws **(1)** and the four black Phillips PM2.0×4.0 screws **(2)** that secure the switch cover to the computer.

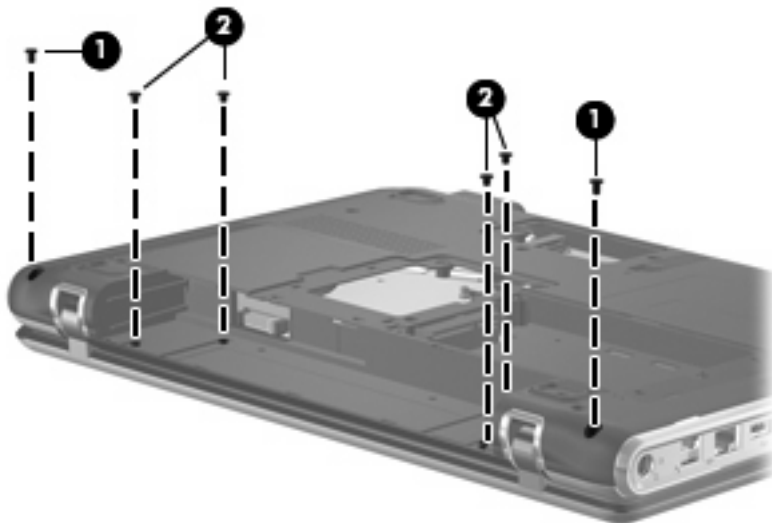

4. Turn the computer right-side up, with the front toward you.
5. Open the computer as far as possible.
6. Release the ZIF connector **(1)** to which the LED board cable **(2)** is connected, and disconnect the cable from the system board.

7. Remove the switch cover (3).

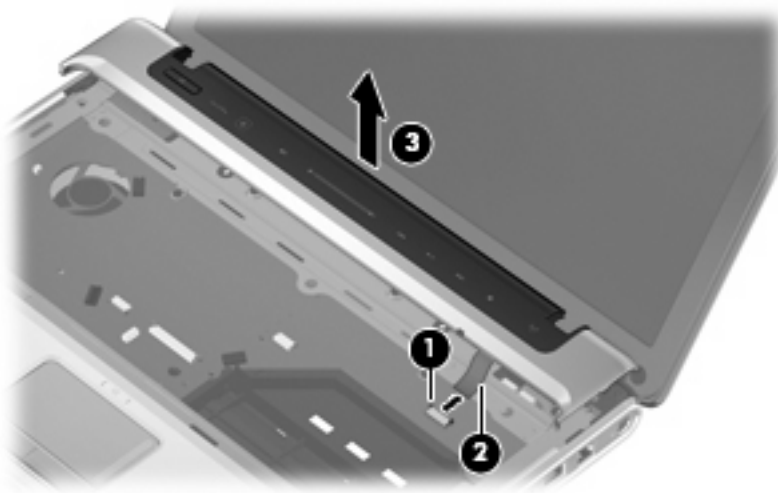

Reverse this procedure to install the switch cover.

Top cover

Description	Spare part number
Top cover for dv3000 models (includes TouchPad and cable, fingerprint reader board cable, and caps lock LED board and cable)	468819-001
Top cover for dv3500 models (includes TouchPad and cable, fingerprint reader board cable, and caps lock LED board and cable)	501011-001

Before removing the top cover, follow these steps:

1. Shut down the computer. If you are unsure whether the computer is off or in Hibernation, turn the computer on, and then shut it down through the operating system.
2. Disconnect all external devices connected to the computer.
3. Disconnect the power from the computer by first unplugging the power cord from the AC outlet and then unplugging the AC adapter from the computer.
4. Remove the battery (see [Battery on page 43](#)).
5. Remove the following components:
 - a. Hard drive (see [Hard drive on page 51](#))
 - b. Optical drive (see [Optical drive on page 48](#))
 - c. Keyboard (see [Keyboard on page 54](#))
 - d. Switch cover (see [Switch cover on page 57](#))

Remove the top cover:

1. Close the computer.
2. Turn the computer upside down, with the rear panel toward you.
3. Remove the six Phillips PM2.5×7.0 screws that secure the top cover to the computer.

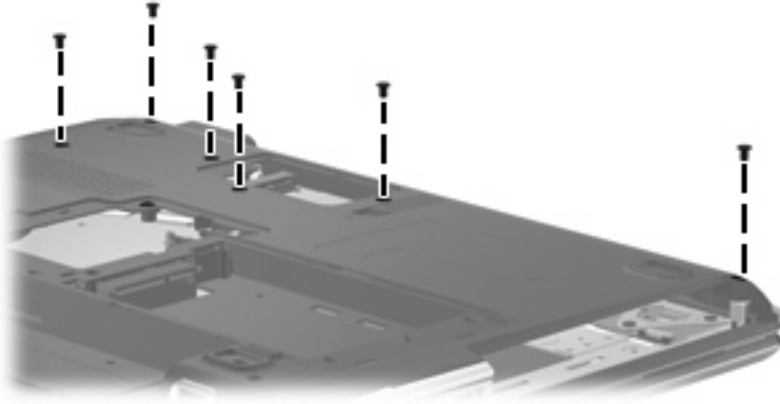

4. Turn the computer right-side up, with the front toward you.
5. Open the computer as far as possible.
6. Disconnect the caps lock LED board cable (1) from the system board.
7. Release the ZIF connector to which the TouchPad board cable is connected, and disconnect the cable (2) from on the system board.
8. Disconnect the TouchPad on/off button board cable (3) from the system board.

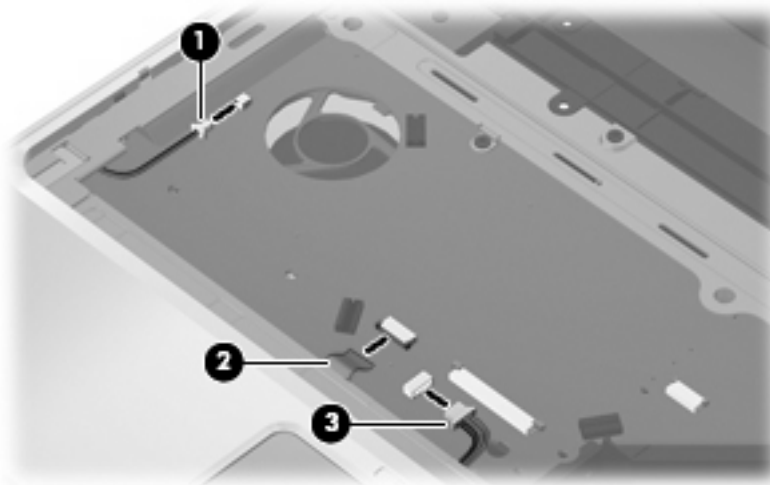

9. Remove the six Phillips PM2.5×7.0 screws (1) and the two Phillips PM2.0×4.0 screws (2) that secure the top cover to the computer.

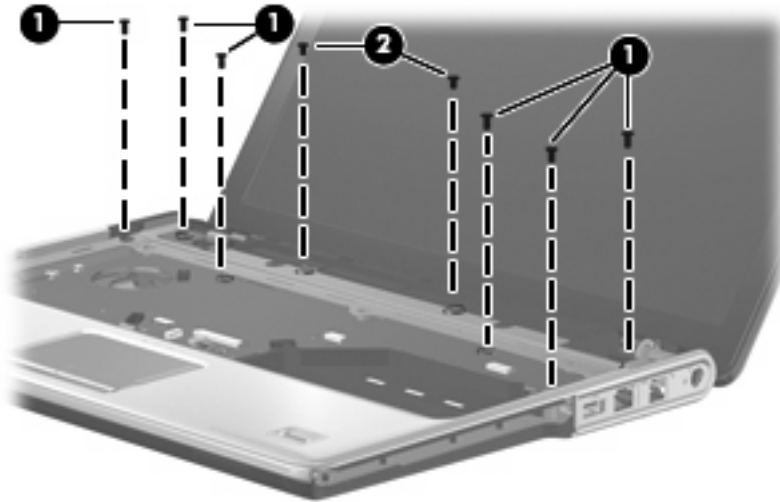

10. Lift the back edge of the top cover (1), and swing it up and forward until all edges of the top cover are disengaged from the base enclosure.
11. Release the ZIF connector to which the fingerprint reader board cable is attached and disconnect the cable (2) from the connector.

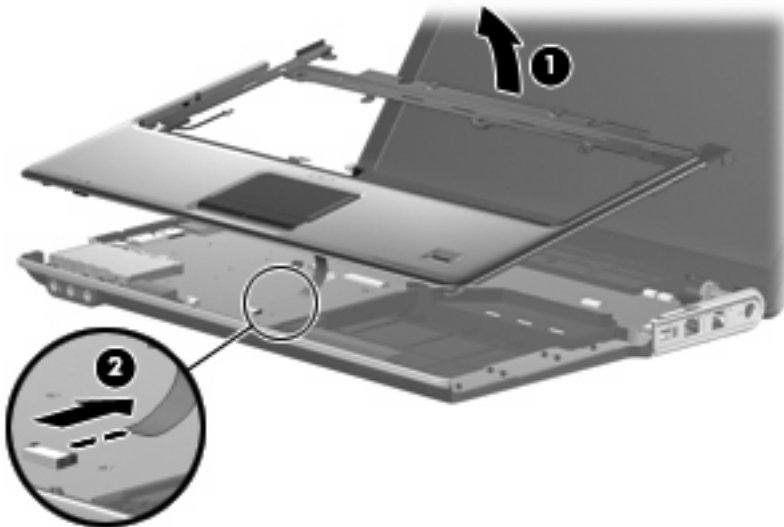

12. Remove the top cover.

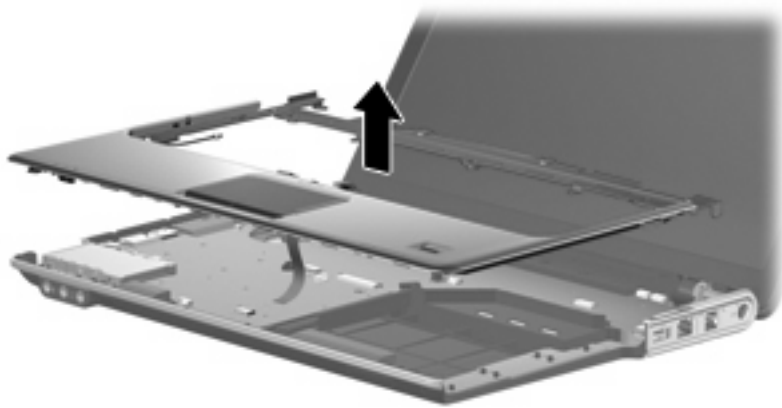

Reverse this procedure to install the top cover.

Fingerprint reader board

Description	Spare part number
Fingerprint reader board dv3000 (includes fingerprint reader board bracket)	468831-001
Fingerprint reader board dv3500 (includes fingerprint reader board bracket)	502464-001

Before removing the fingerprint reader board, follow these steps:

1. Shut down the computer. If you are unsure whether the computer is off or in Hibernation, turn the computer on, and then shut it down through the operating system.
2. Disconnect all external devices connected to the computer.
3. Disconnect the power from the computer by first unplugging the power cord from the AC outlet and then unplugging the AC adapter from the computer.
4. Remove the battery (see [Battery on page 43](#)).
5. Remove the following components:
 - a. Hard drive (see [Hard drive on page 51](#))
 - b. Optical drive (see [Optical drive on page 48](#))
 - c. Keyboard (see [Keyboard on page 54](#))
 - d. Switch cover (see [Switch cover on page 57](#))
 - e. Top cover (see [Top cover on page 58](#))

Remove the fingerprint reader board:

1. Turn the top cover upside down, with the front toward you.
2. Release the ZIF connector to which the fingerprint reader board cable is attached and disconnect the cable (1) from the connector.

3. Remove the three Phillips PM2.0×3.0 screws **(2)** that secure the fingerprint reader board and bracket to the top cover.
4. Remove the fingerprint reader board bracket **(3)** from the top cover.
5. Remove the fingerprint reader board **(4)** from the top cover.

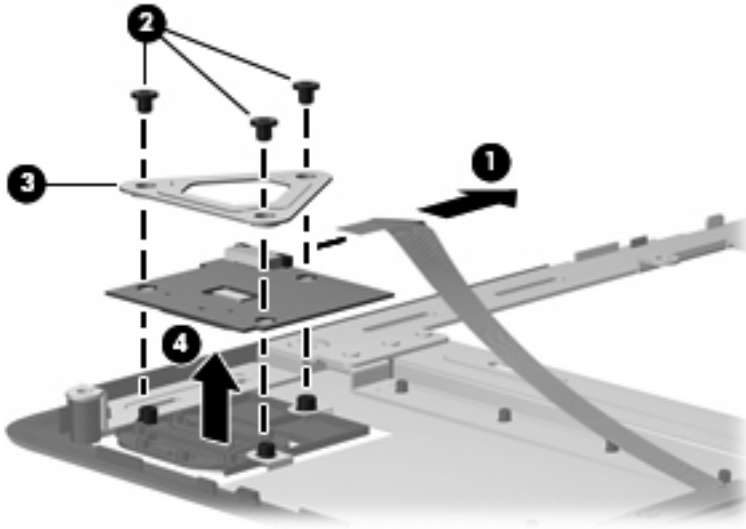

Reverse the above procedure to install the fingerprint reader board.

Display assembly

Description	Spare part number
13.3-inch, WXGA BrightView display assembly for use in dv3000 models (includes webcam/microphone module, webcam/microphone module cable, 2 microphones, and 3 wireless antenna transceivers and cables)	468806-001
13.3-inch, WXGA BrightView display assembly for use in dv3500 models with an LCD display (includes webcam/microphone module, webcam/microphone module cable, 2 microphones, and 3 wireless antenna transceivers and cables)	496107-001
13.3-inch, WXGA BrightView display assembly for use in dv3500 models with an LED display (includes webcam/microphone module, webcam/microphone module cable, 2 microphones, and 3 wireless antenna transceivers and cables)	496108-001

Before removing the display assembly, follow these steps:

1. Shut down the computer. If you are unsure whether the computer is off or in Hibernation, turn the computer on, and then shut it down through the operating system.
2. Disconnect all external devices connected to the computer.
3. Disconnect the power from the computer by first unplugging the power cord from the AC outlet and then unplugging the AC adapter from the computer.
4. Remove the battery (see [Battery on page 43](#)).
5. Disconnect the wireless antenna cables from the WLAN module (see [WLAN module on page 45](#)).
6. Remove the following components:
 - a. Keyboard (see [Keyboard on page 54](#))
 - b. Switch cover (see [Switch cover on page 57](#))
 - c. Top cover (see [Top cover on page 58](#))

Remove the display assembly:

1. Close the computer.
2. Turn the computer upside down, with the rear panel toward you.
3. Remove the two Phillips PM2.5×7.0 screws (1) that secure the display assembly to the computer.

4. Remove the WLAN antenna cables from the channel (2) located between the wireless module compartment and the memory module compartment.

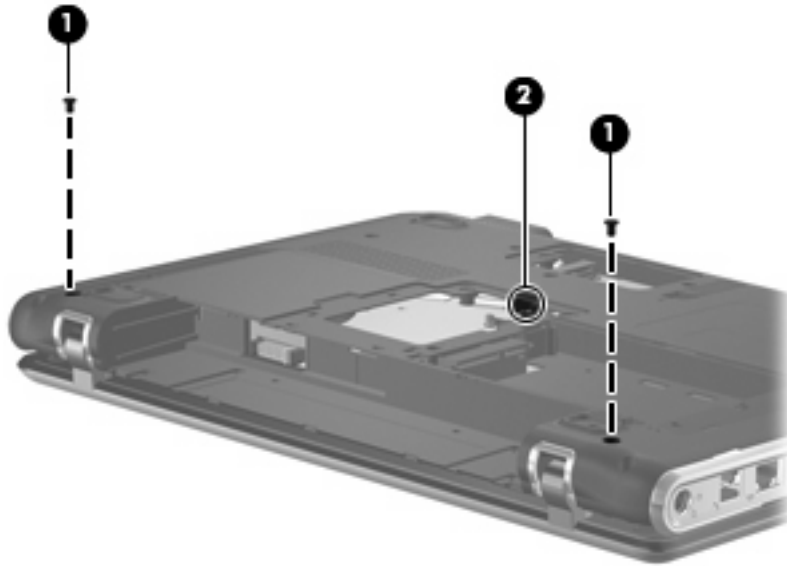

5. Turn the computer right-side up, with the rear panel toward you.
6. Open the computer as far as possible.
7. Disconnect the display panel cable (1) from the system board and remove the cable from the cavity between the system board and the display left hinge.
8. Disconnect the webcam/microphone module cable (2) from the system board.
9. Remove the WLAN antenna cables (3) from the clips and routing channel built into the top cover.

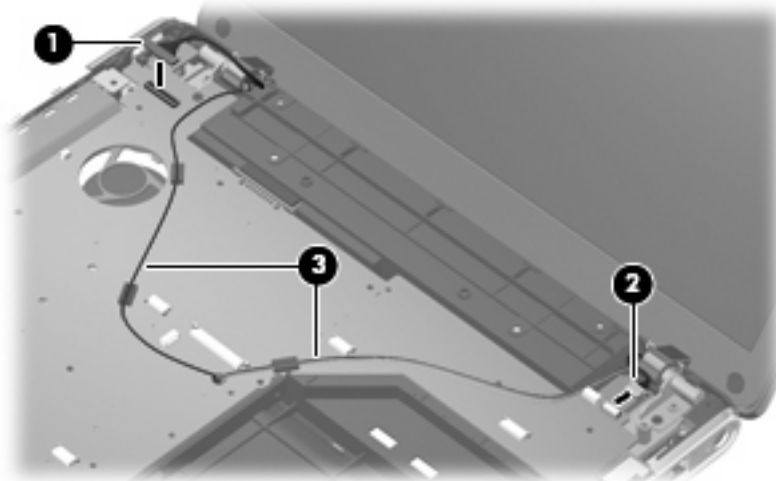

△ **CAUTION:** Support the display assembly when removing the following screws. Failure to support the display assembly can result in damage to the display assembly and other computer components.

10. Remove the two Phillips PM2.5×7.0 screws (1) that secure the display assembly to the computer.

11. Remove the display assembly (2).

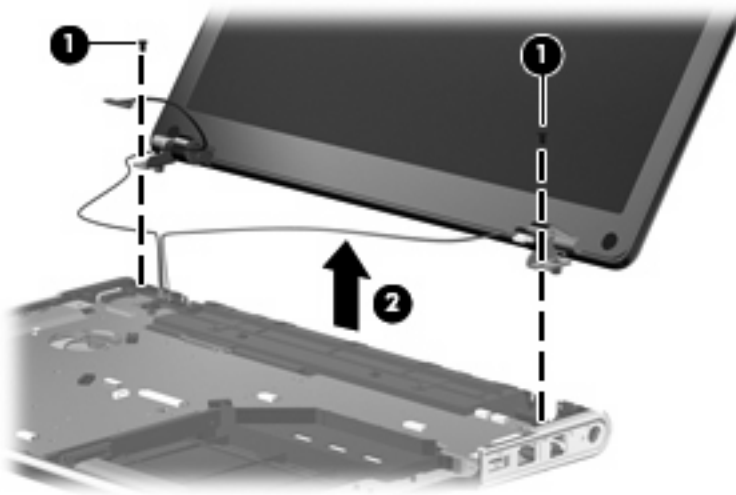

12. If it is necessary to replace any of the display assembly internal components, remove the two rubber screw covers (1) on the display bezel bottom edge. The rubber screw covers are included in the Display Rubber Kit, spare part number 468802-001 for dv3000 models, 500966-001 for dv3500 models with an LCD display, and 502460-001 for dv3500 models with an LED display.
13. Remove the two Phillips PM2.5×5.0 screws (2) that secure the display bezel to the display assembly.

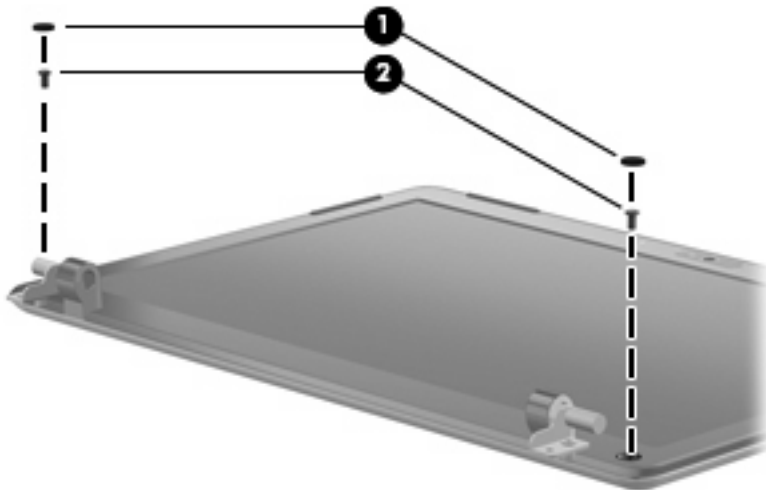

14. Flex the inside edges of the left and right sides (1) and the top and bottom edges (2) of the display bezel until the bezel disengages from the display enclosure.

15. Remove the display bezel (3). The display bezel is available using spare part number 468797-001 on dv3000 models, 500953-001 on dv3500 models with an LCD display, and 500954-001 on dv3500 models with an LED display.

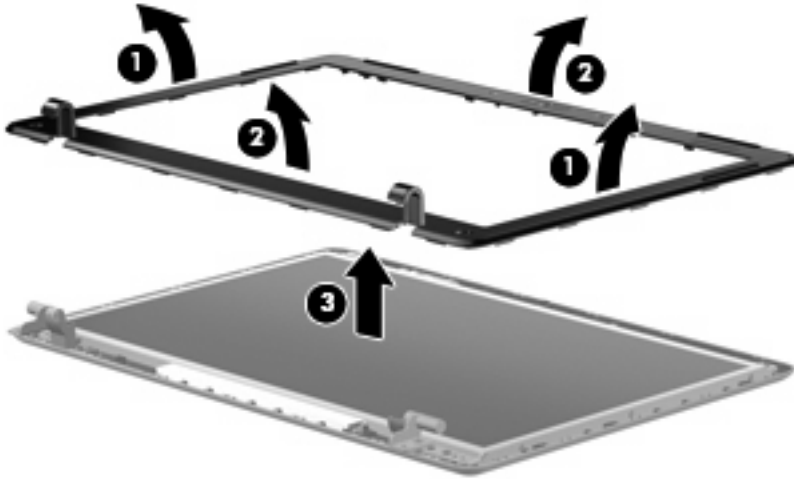

16. If it is necessary to replace the webcam/microphone module, release the module (1) as far as the webcam/microphone module allows.
17. Disconnect the webcam/microphone module cable from the module (2).

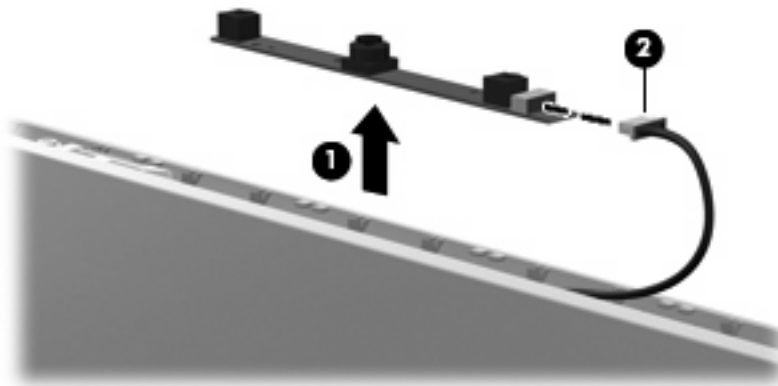

18. Remove the webcam/microphone module. The webcam/microphone module is available using spare part number 468804-001 for dv3000 models, 500967-001 for dv3500 models.
19. If it is necessary to replace the display inverter, release the inverter (1) as far as the display panel cable and the backlight cable will allow.

20. Disconnect the display panel cable (2) and the backlight cable (3) from the display inverter.

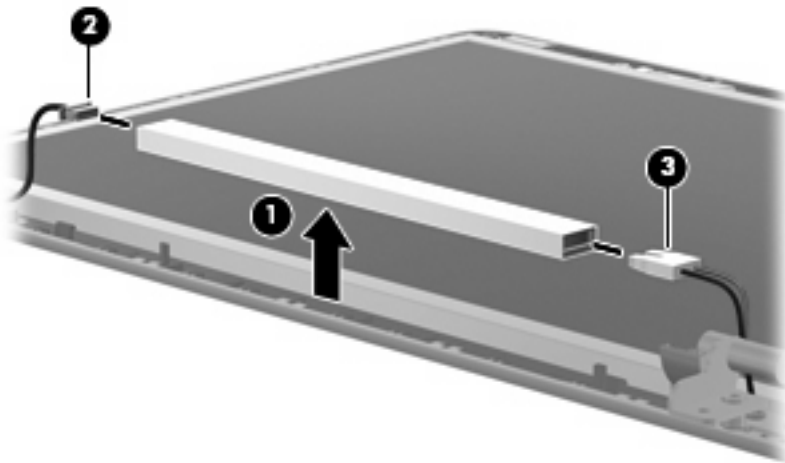

21. Remove the inverter. The display inverter is available using spare part number 468798-001 for dv3000 models, 500957-001 for dv3500 models.
22. If it is necessary to replace the display panel, disconnect the display logo LED board cable (1) from the display panel cable.
23. Remove the six Phillips PM2.5×5.0 screws (2) that secure the panel to the display enclosure.
24. Remove the display panel (3) from the display enclosure. The display panel is available using the spare part number 468796-001 for dv3000 models, 496105-001 for dv3500 models with an LCD display, and 496106-001 for dv3500 models with an LED display.

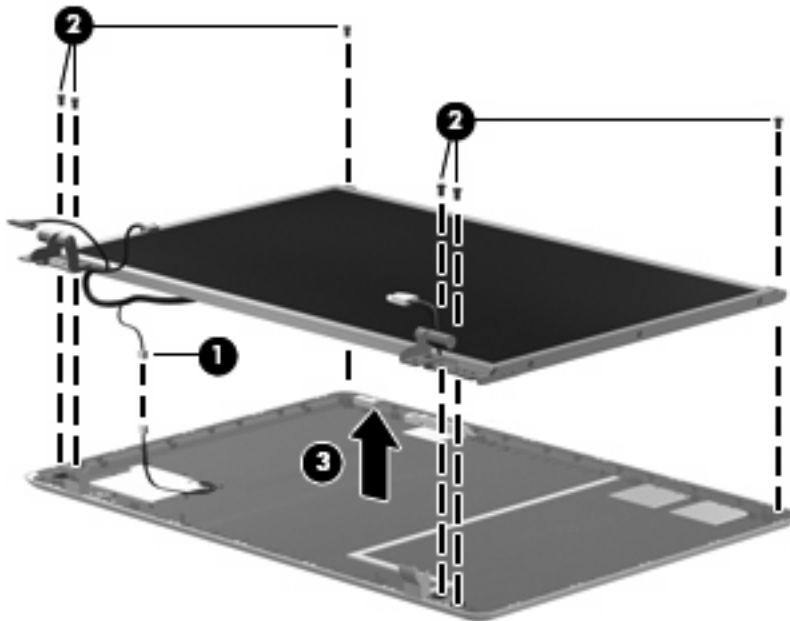

25. If it is necessary to replace the display hinges, remove the three Phillips PM2.0×3.0 screws (1) that secure each hinge to the display panel.

26. Remove the display hinges (2) from the display panel. The display hinges are available using spare part number 468799-001 for dv3000 models, 500959-001 for dv3500 models with an LCD display, 500960-001 for dv3500 models with an LED display.

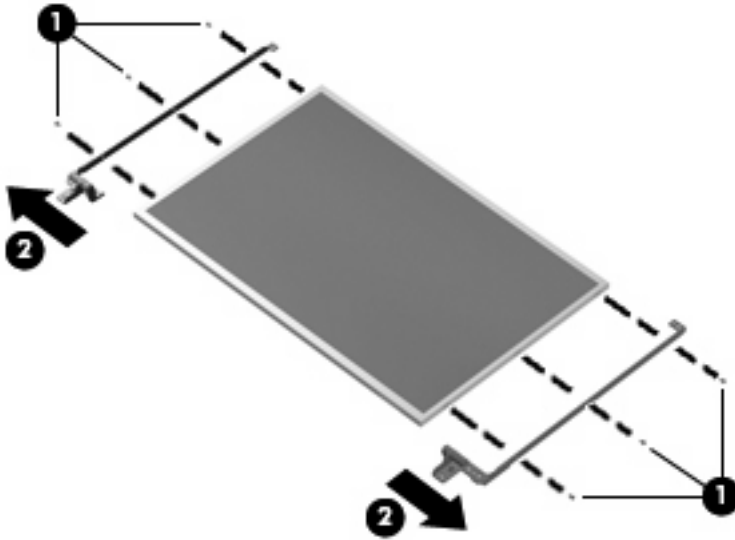

27. If it is necessary to replace the wireless antenna transceivers and cables, remove the Phillips PM2.5×4.0 screw (1) that secures the left transceiver to the display enclosure.
28. Detach the wireless antenna transceivers (2) from the display enclosure.
29. Remove the wireless antenna cables from the clips (3) built into the display enclosure.

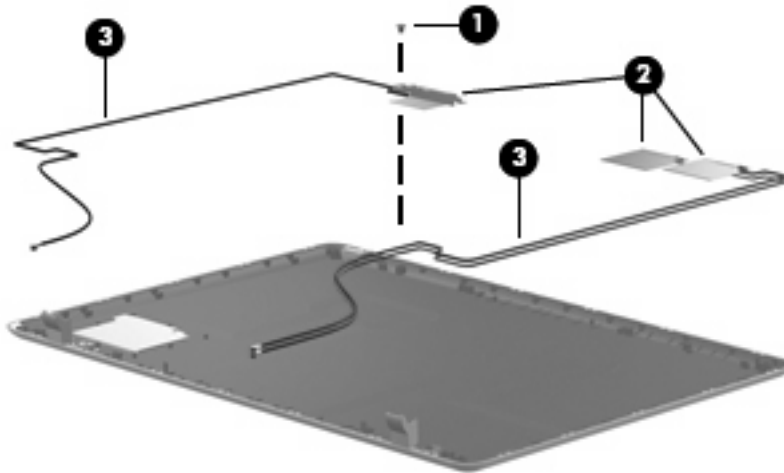

30. Remove the wireless antenna transceivers and cables from the display enclosure. The wireless antenna transceivers and cables are available in the Display Cable Kit, spare part number 468800-001 for dv3000 models, 500961-001 for dv3500 models with an LCD display, 500962-001 for dv3500 models with an LED display.

31. If it is necessary to replace the webcam/microphone module cable, remove the cable from the display enclosure. The webcam/microphone module cable is available using spare part number 468805-001.

 **NOTE:** The webcam/microphone module cable is attached to the display enclosure with double-sided tape.

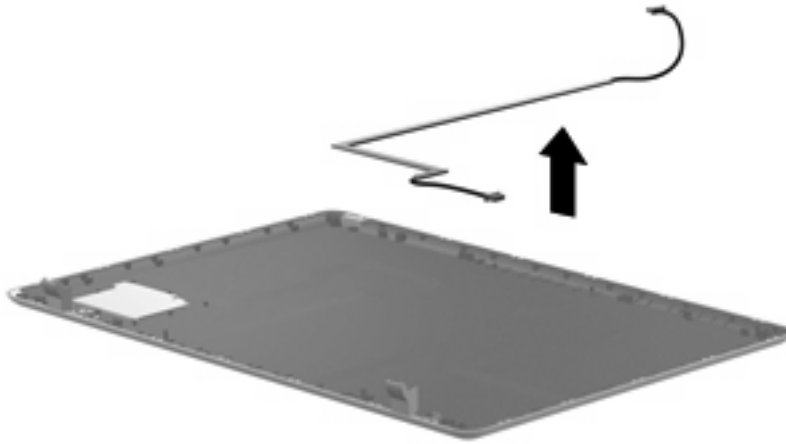

Reverse this procedure to reassemble and install the display assembly.

System board

 **NOTE:** All system board spare part kits include replacement thermal material.

Description	Spare part number
System board for use only in dv3000 models (includes replacement thermal material and power connector cable)	468499-001
System board for use only in dv3500 models (includes replacement thermal material and power connector cable)	496097-001

Before removing the system board, follow these steps:

1. Shut down the computer. If you are unsure whether the computer is off or in Hibernation, turn the computer on, and then shut it down through the operating system.
2. Disconnect all external devices connected to the computer.
3. Disconnect the power from the computer by first unplugging the power cord from the AC outlet and then unplugging the AC adapter from the computer.
4. Remove the battery (see [Battery on page 43](#)).
5. Remove the following components:
 - a. Optical drive (see [Optical drive on page 48](#))
 - b. Hard drive (see [Hard drive on page 51](#))
 - c. Keyboard (see [Keyboard on page 54](#))
 - d. Switch cover (see [Switch cover on page 57](#))
 - e. Top cover (see [Top cover on page 58](#))
 - f. Display assembly (see [Display assembly on page 63](#))

When replacing the system board, be sure that the following components are removed from the defective system board and installed on the replacement system board:

- WLAN module (see [WLAN module on page 45](#))
- Memory modules (see [Memory module on page 49](#))
- RTC battery (see [RTC battery on page 77](#))
- Modem module (see [Modem module on page 79](#))
- Heat sink (see [Heat sink on page 80](#))
- Processor (see [Processor on page 82](#))
- Fan (see [Fan on page 84](#))

Remove the system board:

1. Disconnect the speaker cable (1) and the Bluetooth module cable (2) from the system board.

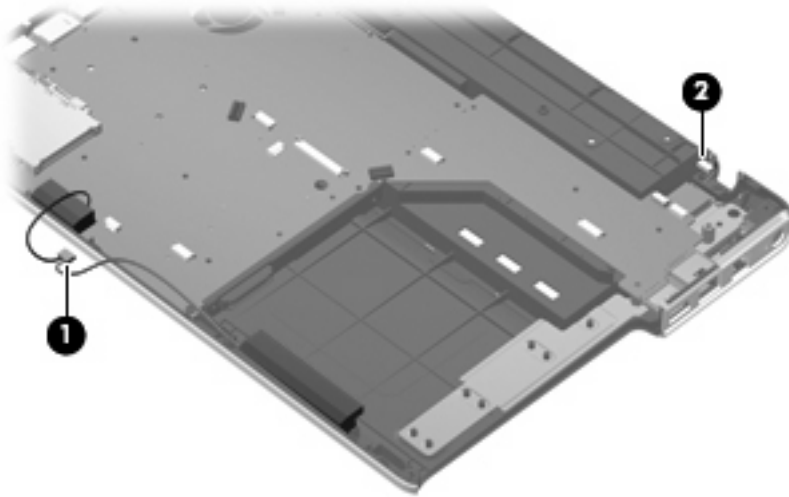

2. Remove the two Phillips PM2.5×5.0 screws (1) that secure the system board to the base enclosure.
3. Remove the two Phillips PM2.0×4.0 screws (2) that secure the power connector to the base enclosure.
4. Remove the power connector (3) and the RJ11 jack (4) from the clips in the base enclosure.

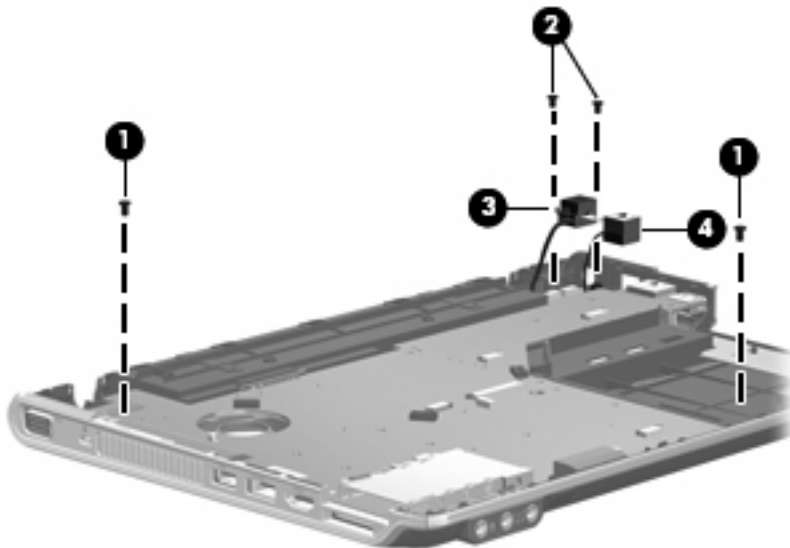

5. Flex the right side of the base enclosure (1) above the USB port and RJ45 jack.

6. Use the optical drive connector (2) to lift right side of the system board (3) until the USB port and RJ45 jack are clear of the base enclosure.

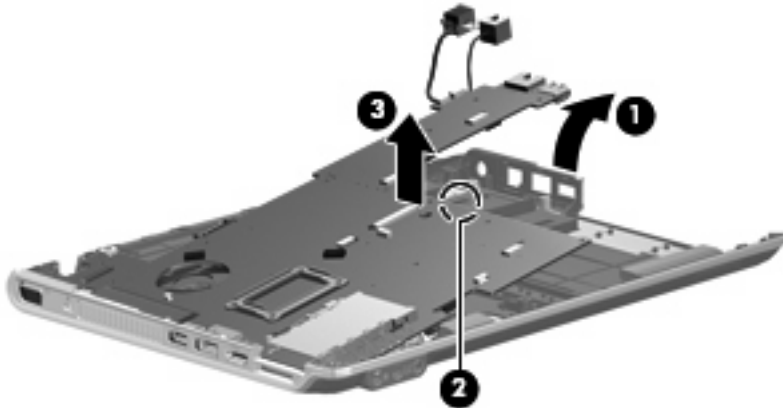

7. Flex the left side of the base enclosure (1) above the external monitor port.
8. Lift back edge of the system board (2) until the external monitor port is clear of the base enclosure.

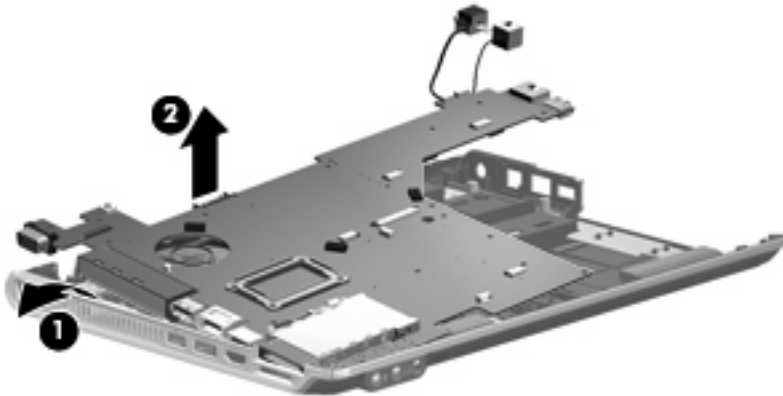

9. Flex the left side of the base enclosure (1) above the eSATA connector and HDMI connector.
10. Lift the back edge of the system board (2) until the eSATA connector and HDMI connector are clear of the base enclosure.

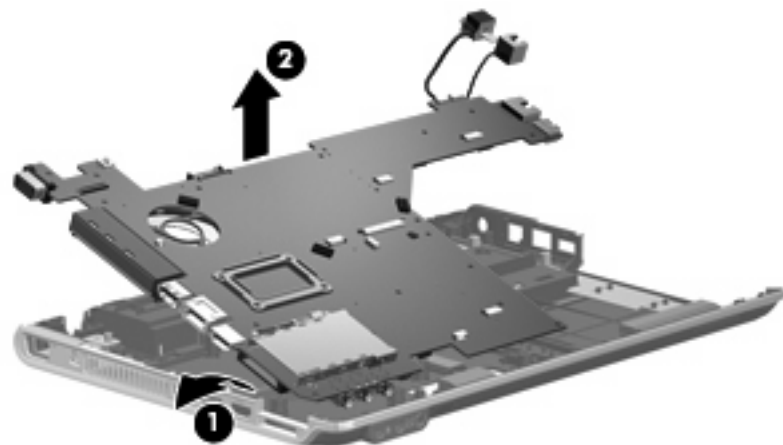

11. Remove the system board by pulling it away from the base enclosure at an angle.

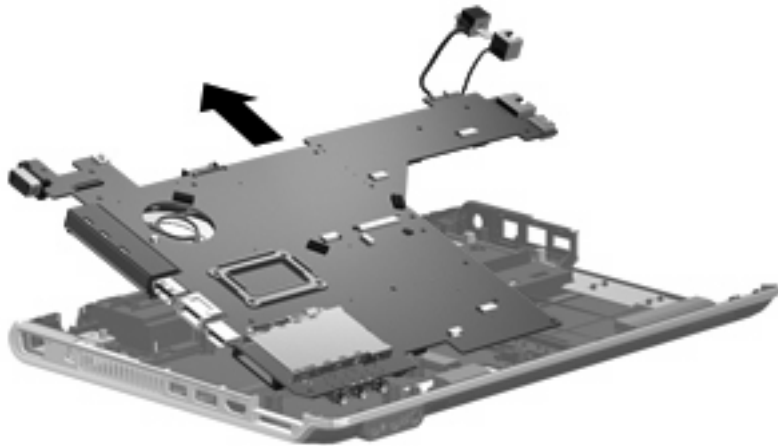

Reverse the preceding procedure to install the system board.

Speakers

Description	Spare part number
Speakers	468828-001

Before removing the speakers, follow these steps:

1. Shut down the computer. If you are unsure whether the computer is off or in Hibernation, turn the computer on, and then shut it down through the operating system.
2. Disconnect all external devices connected to the computer.
3. Disconnect the power from the computer by first unplugging the power cord from the AC outlet and then unplugging the AC adapter from the computer.
4. Remove the battery (see [Battery on page 43](#)).
5. Remove the following components:
 - a. Optical drive (see [Optical drive on page 48](#))
 - b. Hard drive (see [Hard drive on page 51](#))
 - c. Keyboard (see [Keyboard on page 54](#))
 - d. Switch cover (see [Switch cover on page 57](#))
 - e. Top cover (see [Top cover on page 58](#))
 - f. Display assembly (see [Display assembly on page 63](#))
 - g. System board (see [System board on page 70](#))

Remove the speakers:

- Remove the speakers from the base enclosure.

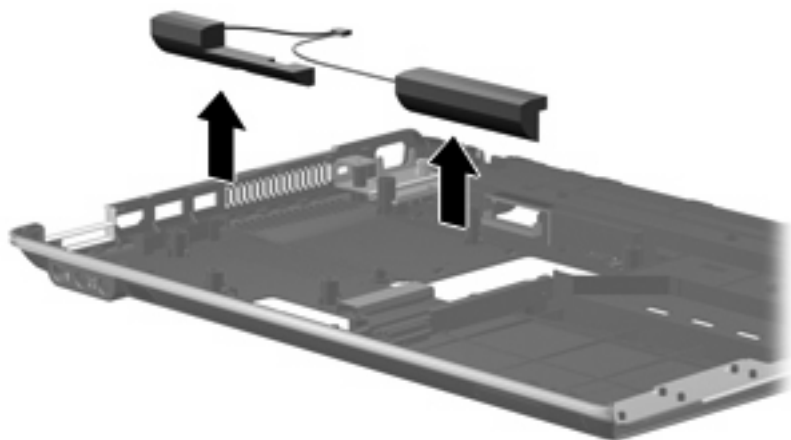

Reverse this procedure to install the speakers.

Bluetooth module

 **NOTE:** The Bluetooth module spare part kit does not include a Bluetooth module cable. The Bluetooth module cable is included in the Cable Kit, spare part number 468827-001 for dv3000 models, 502463-001 for dv3500 models.

Description	Spare part number
Bluetooth module (includes double-sided tape)	398393-002

Before removing the Bluetooth module, follow these steps:

1. Shut down the computer. If you are unsure whether the computer is off or in Hibernation, turn the computer on, and then shut it down through the operating system.
2. Disconnect all external devices connected to the computer.
3. Disconnect the power from the computer by first unplugging the power cord from the AC outlet and then unplugging the AC adapter from the computer.
4. Remove the battery (see [Battery on page 43](#)).
5. Remove the following components:
 - a. Optical drive (see [Optical drive on page 48](#))
 - b. Hard drive (see [Hard drive on page 51](#))
 - c. Keyboard (see [Keyboard on page 54](#))
 - d. Switch cover (see [Switch cover on page 57](#))
 - e. Top cover (see [Top cover on page 58](#))
 - f. Display assembly (see [Display assembly on page 63](#))
 - g. System board (see [System board on page 70](#))

Remove the Bluetooth module:

- Remove the Bluetooth module from the base enclosure.

 **NOTE:** The Bluetooth module is attached to the system board with double-sided tape.

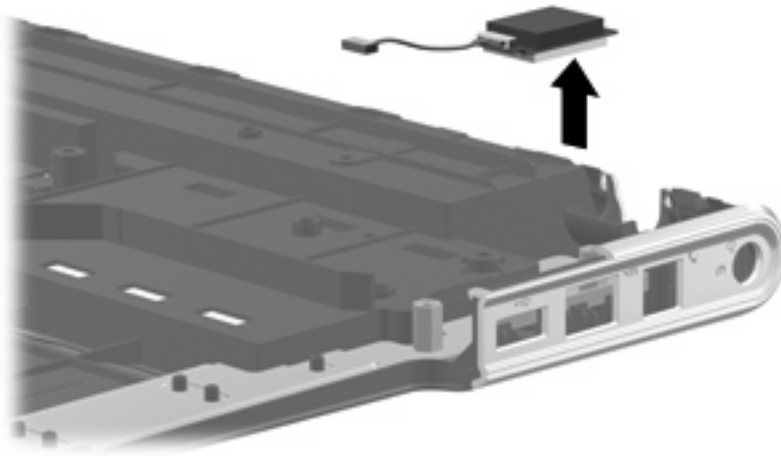

Reverse this procedure to install the Bluetooth module.

RTC battery

 **NOTE:** Removing the RTC battery and leaving it uninstalled for 5 or more minutes causes all passwords and CMOS settings to be cleared.

Description	Spare part number
RTC battery (includes double-sided tape)	468824-001

Before removing the RTC battery, follow these steps:

1. Shut down the computer. If you are unsure whether the computer is off or in Hibernation, turn the computer on, and then shut it down through the operating system.
2. Disconnect all external devices connected to the computer.
3. Disconnect the power from the computer by first unplugging the power cord from the AC outlet and then unplugging the AC adapter from the computer.
4. Remove the battery (see [Battery on page 43](#)).
5. Remove the following components:
 - a. Optical drive (see [Optical drive on page 48](#))
 - b. Hard drive (see [Hard drive on page 51](#))
 - c. Keyboard (see [Keyboard on page 54](#))
 - d. Switch cover (see [Switch cover on page 57](#))
 - e. Top cover (see [Top cover on page 58](#))
 - f. Display assembly (see [Display assembly on page 63](#))
 - g. System board (see [System board on page 70](#))

Remove the RTC battery:

1. Turn the system board upside down, with the battery connector toward you.
2. Disconnect the RTC battery cable (1) from the system board.

3. Remove the RTC battery (2).

 **NOTE:** The RTC battery is attached to the system board with double-sided tape.

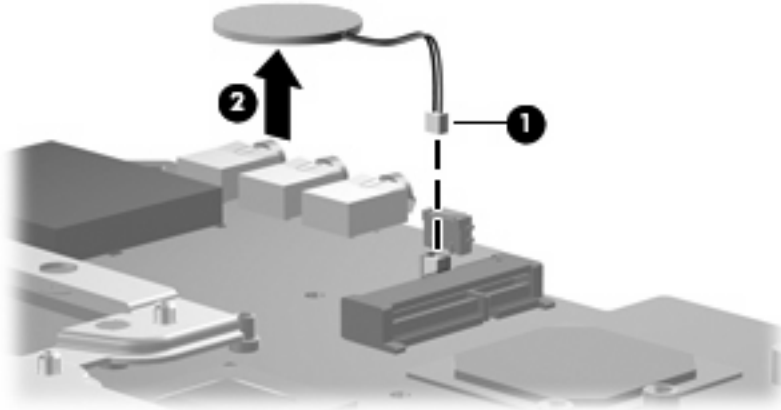

Reverse this procedure to install the RTC battery.

Modem module

 **NOTE:** The modem module spare part kits do not include a modem module cable. The modem module cable is included in the Cable Kit, spare part number 468827-001 for dv3000 models, 502463-001 for dv3500 models.

Description	Spare part number
For use in dv3000 models in all countries and regions except Australia and New Zealand	468825-001
For use only in dv3000 models in Australia and New Zealand	468825-011
For use in dv3500 models in all countries and regions except Australia and New Zealand	461749-001
For use only in dv3500 models in Australia and New Zealand	461749-011

Before removing the modem module, follow these steps:

1. Shut down the computer. If you are unsure whether the computer is off or in Hibernation, turn the computer on, and then shut it down through the operating system.
2. Disconnect all external devices connected to the computer.
3. Disconnect the power from the computer by first unplugging the power cord from the AC outlet and then unplugging the AC adapter from the computer.
4. Remove the battery (see [Battery on page 43](#)).
5. Remove the following components:
 - a. Optical drive (see [Optical drive on page 48](#))
 - b. Hard drive (see [Hard drive on page 51](#))
 - c. Keyboard (see [Keyboard on page 54](#))
 - d. Switch cover (see [Switch cover on page 57](#))
 - e. Top cover (see [Top cover on page 58](#))
 - f. Display assembly (see [Display assembly on page 63](#))
 - g. System board (see [System board on page 70](#))

Remove the modem module:

1. Turn the system board upside down, with the battery connector toward you.
2. Remove the modem module cable **(1)** from the clips **(2)** built into the system board.

 **NOTE:** The modem module cable is included in the Cable Kit, spare part number 468827-001 for dv3000 models, 502463-001 for dv3500 models.

3. Remove the two Phillips PM2.5×4.0 screws **(3)** that secure the modem module to the system board.

4. Lift the modem module (4) straight up to disconnect it from the system board.

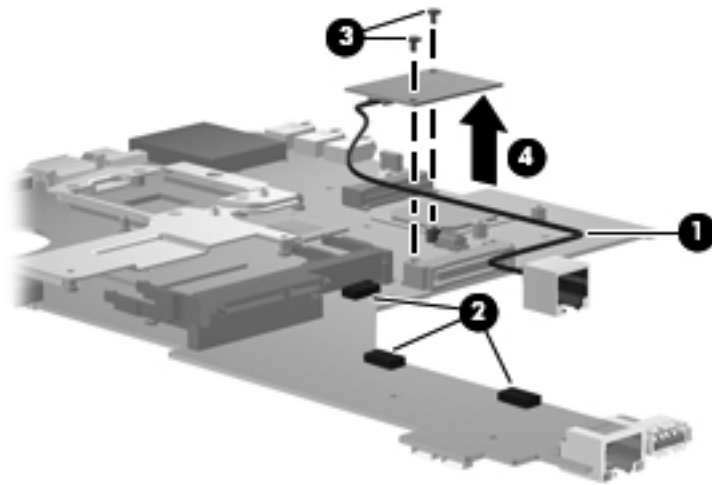

5. Remove the modem module.

Reverse the above procedure to install the modem module.

Heat sink

Description	Spare part number
Heat sink for use in dv3000 models (includes heat sink retention clip and replacement thermal material)	468829-001
Heat sink for use in dv3500 models (includes heat sink retention clip and replacement thermal material)	501015-001

Before removing the heat sink, follow these steps:

1. Shut down the computer. If you are unsure whether the computer is off or in Hibernation, turn the computer on, and then shut it down through the operating system.
2. Disconnect all external devices connected to the computer.
3. Disconnect the power from the computer by first unplugging the power cord from the AC outlet and then unplugging the AC adapter from the computer.
4. Remove the battery (see [Battery on page 43](#)).
5. Remove the following components:
 - a. Optical drive (see [Optical drive on page 48](#))
 - b. Hard drive (see [Hard drive on page 51](#))
 - c. Keyboard (see [Keyboard on page 54](#))
 - d. Switch cover (see [Switch cover on page 57](#))
 - e. Top cover (see [Top cover on page 58](#))

- f. Display assembly (see [Display assembly on page 63](#))
- g. System board (see [System board on page 70](#))

Remove the heat sink:

1. Turn the system board upside down, with the battery connector toward you.
2. Loosen the two Phillips PM2.0×5.0 captive screws (1) that secure the heat sink to the system board
3. Lift the right side of the heat sink retention clip (2) until it rests at an angle.
4. Remove the heat sink retention clip (3) by sliding it to the right.

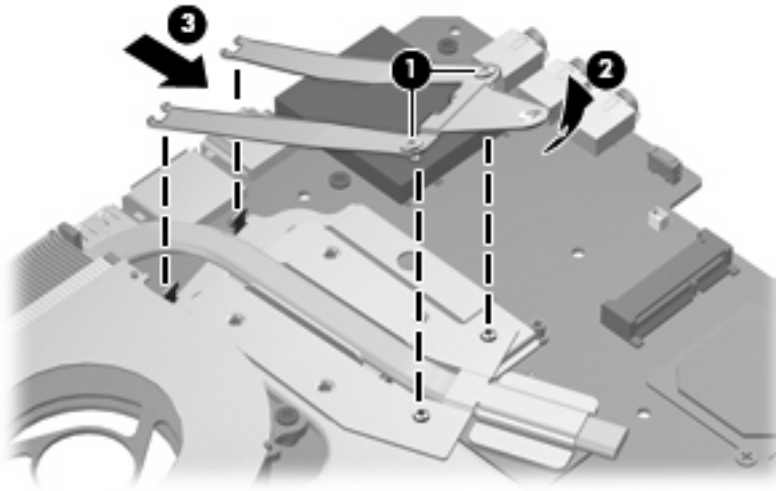

 **NOTE:** Due to the adhesive quality of the thermal material located between the heat sink and system board components, it may be necessary to move the heat sink from side to side to detach the assembly.

5. Remove the heat sink.

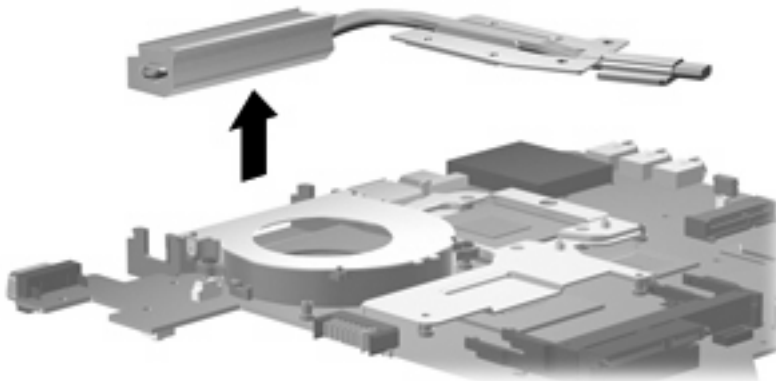

 **NOTE:** The thermal material must be thoroughly cleaned from the surfaces of the heat sink (1) and (2), the processor (3), and the graphics chip (4) each time the heat sink is removed. Thermal pads and thermal paste must be installed on all surfaces before the heat sink is reinstalled. Thermal pads and thermal paste are included with all heat sink, system board, and processor spare part kits.

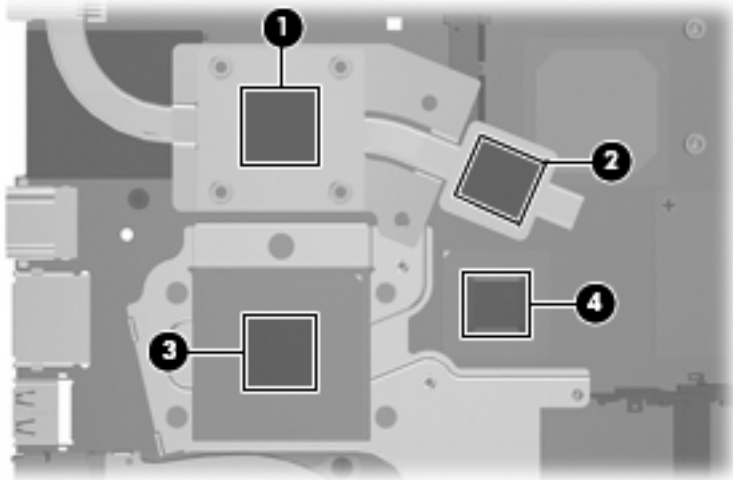

Reverse this procedure to install the heat sink.

Processor

 **NOTE:** All processor spare part kits include replacement thermal material.

Description	Spare part number
Processors for use in dv3000 models:	
Intel Core2 Duo T9500 2.60-GHz processor (6-MB L2 cache, 800-MHz FSB)	459609-001
Intel Core2 Duo T9300 2.50-GHz processor (6-MB L2 cache, 800-MHz FSB)	459608-001
Intel Core2 Duo T8300 2.40-GHz processor (3-MB L2 cache, 800-MHz FSB)	459607-001
Intel Core2 Duo T8100 2.10-GHz processor (3-MB L2 cache, 800-MHz FSB)	459606-001
Intel Core2 Duo T5850 2.16-GHz processor (2-MB of L2 cache, 667-MHz FSB)	482351-001
Intel Core2 Duo T5550 1.83-GHz processor (2-MB of L2 cache, 667-MHz FSB)	458247-001
Pentium Dual Core T2390 1.86-GHz processor (1-MB of L2 cache, 533-MHz FSB)	492593-001
Processors for use in dv3500 models:	
Intel Core2 Duo T9400 2.53-GHz processor (6-MB L2 cache, 1066-MHz FSB)	496098-001
Intel Core2 Duo P8600 2.40-GHz processor (3-MB L2 cache, 1066-MHz FSB)	496099-001
Intel Core2 Duo P8400 2.26-GHz processor (3-MB L2 cache, 1066-MHz FSB)	496100-001
Intel Core2 Duo T7350 2.00-GHz processor (3-MB L2 cache, 1066-MHz FSB)	501017-001
Intel Core2 Duo T5900 2.20-GHz processor (2-MB L2 cache, 800-MHz FSB)	496103-001
Intel Core2 Duo T5800 2.00-GHz processor (2-MB L2 cache, 800-MHz FSB)	496102-001
Intel Core2 Duo T3200 2.00-GHz processor (1-MB L2 cache, 800-MHz FSB)	496104-001

Before removing the processor, follow these steps:

1. Shut down the computer. If you are unsure whether the computer is off or in Hibernation, turn the computer on, and then shut it down through the operating system.
2. Disconnect all external devices connected to the computer.
3. Disconnect the power from the computer by first unplugging the power cord from the AC outlet and then unplugging the AC adapter from the computer.
4. Remove the battery (see [Battery on page 43](#)).
5. Remove the following components:
 - a. Optical drive (see [Optical drive on page 48](#))
 - b. Hard drive (see [Hard drive on page 51](#))
 - c. Keyboard (see [Keyboard on page 54](#))
 - d. Switch cover (see [Switch cover on page 57](#))
 - e. Top cover (see [Top cover on page 58](#))
 - f. Display assembly (see [Display assembly on page 63](#))
 - g. System board (see [System board on page 70](#))
 - h. Heat sink (see [Heat sink on page 80](#))

Remove the processor:

1. Turn the processor locking screw (1) one-half turn counterclockwise until you hear a click.
2. Lift the processor (2) straight up and remove it.

 **NOTE:** When you install the processor, the gold triangle (3) on the processor must be aligned with the triangle icon (4) embossed on the processor slot.

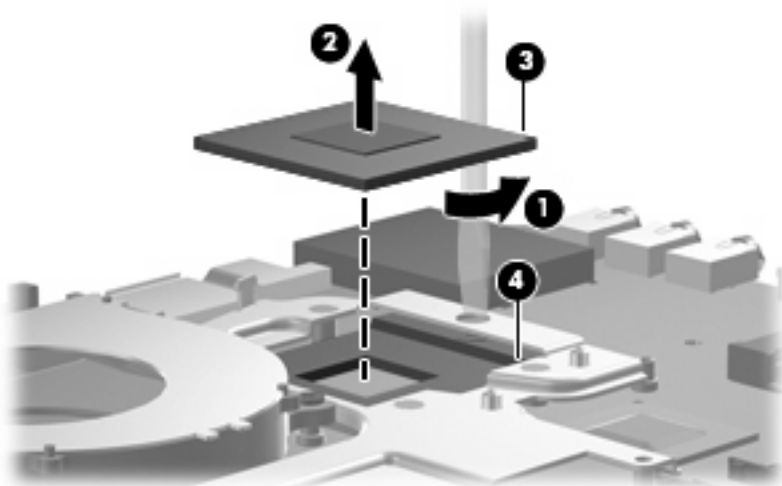

Reverse this procedure to install the processor.

Fan

Description	Spare part number
Fan	468830-001

 **NOTE:** To properly ventilate the computer, allow at least a 7.6-cm (3-inch) clearance on the left side of the computer. The computer uses an electric fan for ventilation. The fan is controlled by a temperature sensor and is designed to turn on automatically when high temperature conditions exist. These conditions are affected by high external temperatures, system power consumption, power management/battery conservation configurations, battery fast charging, and software requirements. Exhaust air is displaced through the ventilation grill located on the left side of the computer.

Before removing the fan, follow these steps:

1. Shut down the computer. If you are unsure whether the computer is off or in Hibernation, turn the computer on, and then shut it down through the operating system.
2. Disconnect all external devices connected to the computer.
3. Disconnect the power from the computer by first unplugging the power cord from the AC outlet and then unplugging the AC adapter from the computer.
4. Remove the battery (see [Battery on page 43](#)).
5. Remove the following components:
 - a. Optical drive (see [Optical drive on page 48](#))
 - b. Hard drive (see [Hard drive on page 51](#))
 - c. Keyboard (see [Keyboard on page 54](#))
 - d. Switch cover (see [Switch cover on page 57](#))
 - e. Top cover (see [Top cover on page 58](#))
 - f. Display assembly (see [Display assembly on page 63](#))
 - g. System board (see [System board on page 70](#))
 - h. Heat sink (see [Heat sink on page 80](#))

Remove the fan:

1. Disconnect the fan cable **(1)** from the system board.
2. Remove the two Phillips PM2.0×4.0 screws **(2)** that secure the fan to the system board.

3. Remove the fan (3).

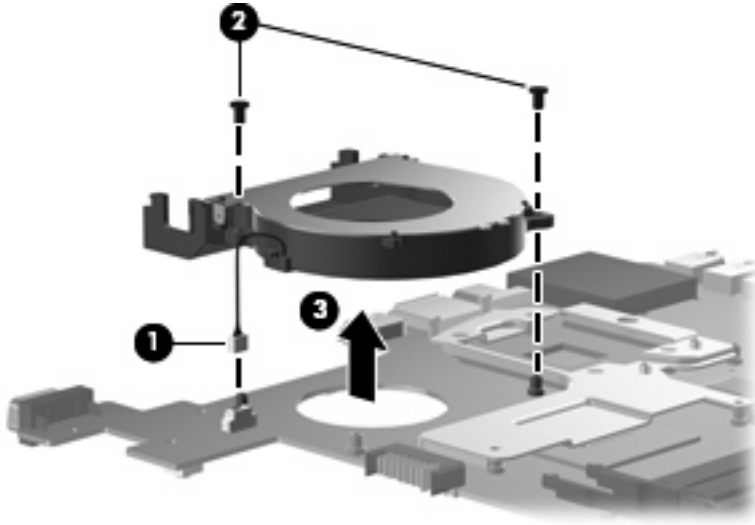

Reverse this procedure to install the fan.

5 Setup Utility

Starting the Setup Utility

The Setup Utility is a ROM-based information and customization utility that can be used even when your Windows® operating system is not working.

 **NOTE:** The fingerprint reader (select models only) cannot be used to access the Setup Utility.

The utility reports information about the computer and provides settings for startup, security, and other preferences.

To start the Setup Utility:

- Open the Setup Utility by turning on or restarting the computer. While the “Press the ESC key for Startup Menu” message is displayed in the lower-left corner of the screen, press **f10**.

– or –

1. Open the Setup Utility by turning on or restarting the computer. While the “Press the ESC key for Startup Menu” message is displayed in the lower-left corner of the screen, press **esc**.
2. When the Startup Menu is displayed, press **f10**.

Using the Setup Utility

Changing the language of the Setup Utility

The following procedure explains how to change the language of the Setup Utility. If the Setup Utility is not already running, begin at step 1. If the Setup Utility is already running, begin at step 2.

1. Open the Setup Utility by turning on or restarting the computer. While the “Press the ESC key for Startup Menu” message is displayed in the lower-left corner of the screen, press **f10**.

– or –

Open the Setup Utility by turning on or restarting the computer. While the “Press the ESC key for Startup Menu” message is displayed in the lower-left corner of the screen, press **esc**. When the Startup Menu is displayed, press **f10**.

2. Use the arrow keys to select **System Configuration > Language**, and then press **enter**.
3. Use the arrow keys to select a language, and then press **enter**.
4. When a confirmation prompt with your language selected is displayed, press **enter**.
5. To save your change and exit the Setup Utility, use the arrow keys to select **Exit > Exit Saving Changes**, and then press **enter**.

Your change goes into effect immediately.

Navigating and selecting in the Setup Utility

Because the Setup Utility is not Windows based, it does not support the TouchPad. Navigation and selection are by keystroke.

- To choose a menu or a menu item, use the arrow keys.
- To choose an item in a list or to toggle a field, for example an Enable/Disable field, use either the arrow keys or **f5** or **f6**.
- To select an item, press **enter**.
- To close a text box or return to the menu display, press **esc**.
- To display additional navigation and selection information while the Setup Utility is open, press **f1**.

Displaying system information

The following procedure explains how to display system information in the Setup Utility. If the Setup Utility is not open, begin at step 1. If the Setup Utility is open, begin at step 2.

1. Open the Setup Utility by turning on or restarting the computer. While the “Press the ESC key for Startup Menu” message is displayed in the lower-left corner of the screen, press **f10**.

– or –

Open the Setup Utility by turning on or restarting the computer. While the “Press the ESC key for Startup Menu” message is displayed in the lower-left corner of the screen, press **esc**. When the Startup Menu is displayed, press **f10**.

2. Select the **Main** menu. System information such as the system time and date, and identification information about the computer is displayed.
3. To exit the Setup Utility without changing any settings, use the arrow keys to select **Exit > Exit Discarding Changes**, and then press **enter**.

Restoring default settings in the Setup Utility

The following procedure explains how to restore the Setup Utility default settings. If the Setup Utility is not already running, begin at step 1. If the Setup Utility is already running, begin at step 2.

1. Open the Setup Utility by turning on or restarting the computer. While the “Press the ESC key for Startup Menu” message is displayed in the lower-left corner of the screen, press **f10**.

– or –

Open the Setup Utility by turning on or restarting the computer. While the “Press the ESC key for Startup Menu” message is displayed in the lower-left corner of the screen, press **esc**. When the Startup Menu is displayed, press **f10**.

2. Use the arrow keys to select **Exit > Load Setup Defaults**, and then press **enter**.
3. When the Setup Confirmation is displayed, press **enter**.
4. To save your change and exit the Setup Utility, use the arrow keys to select **Exit > Exit Saving Changes**, and then press **enter**.

The Setup Utility default settings go into effect when the computer restarts.

 **NOTE:** Your password, security, and language settings are not changed when you restore the factory default settings.

Exiting the Setup Utility

You can exit the Setup Utility with or without saving changes.

- To exit the Setup Utility and save your changes from the current session:

If the Setup Utility menus are not visible, press **esc** to return to the menu display. Then use the arrow keys to select **Exit > Exit Saving Changes**, and then press **enter**.

- To exit the Setup Utility without saving your changes from the current session:

If the Setup Utility menus are not visible, press **esc** to return to the menu display. Then use the arrow keys to select **Exit > Exit Discarding Changes**, and then press **enter**.

After either choice, the computer restarts in Windows.

Setup Utility menus

The menu tables in this section provide an overview of Setup Utility options.

 **NOTE:** Some of the Setup Utility menu items listed in this chapter may not be supported by your computer.

Main menu

Select	To do this
System information	<ul style="list-style-type: none">• View and change the system time and date.• View identification information about the computer.• View specification information about the processor, memory size, system BIOS, and keyboard controller version (select models only).

Security menu

Select	To do this
Administrator password	Enter, change, or delete an administrator password.
Power-On Password	Enter, change, or delete a power-on password.

System Configuration menu

Select	To do this
Language Support	Change the Setup Utility language.
Button Sound (select models only)	Enable/disable the capacitive button tapping sound.
Virtualization Technology	Enable/disable the processor Virtualization Technology.
Processor C4 State (select models only)	Enable/disable the processor C4 sleep state.
LAN Power Saving (select models only)	Enable/disable LAN Power Saving. When enabled, saves power when the computer is in DC mode.
Card Reader/1394 Power Saving (select models only)	Enable/disable Card Reader/1394 Power Saving.

Select	To do this
Fan Always On	Enabled/disable Fan Always On. When enabled, the computer fan will always be on.
Boot Options	<p>Set the following boot options:</p> <ul style="list-style-type: none"> • f9 and f10 Delay (sec.)—Set the delay for the f9 and f10 functions of the Setup Utility in intervals of 5 seconds each (0, 5, 10, 15, 20). • CD-ROM boot—Enable/disable boot from CD-ROM. • Floppy boot—Enable/disable boot from diskette. • Internal Network Adapter boot—Enable/disable boot from Internal Network Adapter. • Boot Order—Set the boot order for: <ul style="list-style-type: none"> ◦ USB Floppy ◦ Internal CD/DVD ROM Drive ◦ Hard drive ◦ USB Diskette on Key ◦ USB Hard drive ◦ Network adapter

Diagnostics menu

Select	To do this
Hard Disk Self Test	<p>Run a comprehensive self-test on the hard drive.</p> <p>NOTE: On models with two hard drives, this menu option is called the Primary Hard Disk Self Test.</p>
Secondary Hard Disk Self Test (select models only)	Run a comprehensive self-test on a secondary hard drive.
Memory Test	Run a diagnostic test on the system memory.

6 Specifications

Computer specifications

	Metric	U.S.
Dimensions		
Length	22.80 cm	8.98 in
Width	32.00 cm	12.60 in
Height (front to rear)	3.17 to 3.82 cm	1.25 to 1.50 in
Weight (with optical drive, hard drive, and battery)	2.23 kg	4.92 lbs
Input power		
Operating voltage	18.5 V dc —19.0 V dc	
Operating current	3.5 A or 4.74 A	
Temperature		
Operating (not writing to optical disc)	0°C to 35°C	32°F to 95°F
Operating (writing to optical disc)	5°C to 35°C	41°F to 95°F
Nonoperating	-20°C to 60°C	-4°F to 140°F
Relative humidity		
Operating	10% to 90%	
Nonoperating	5% to 95%	
Maximum altitude (unpressurized)		
Operating	-15 m to 3,048 m	-50 ft to 10,000 ft
Nonoperating	-15 m to 12,192 m	-50 ft to 40,000 ft
Shock		
Operating	125 g, 2 ms, half-sine	
Nonoperating	200 g, 2 ms, half-sine	
Random vibration		
Operating	0.75 g zero-to-peak, 10 Hz to 500 Hz, 0.25 oct/min sweep rate	

	Metric	U.S.
Nonoperating	1.50 g zero-to-peak, 10 Hz to 500 Hz, 0.5 oct/min sweep rate	

NOTE: Applicable product safety standards specify thermal limits for plastic surfaces. The computer operates well within this range of temperatures.

13.3-inch, WXGA, BrightView display specifications

	Metric	U.S.
Dimensions		
Height	18.0 cm	7.1 in
Width	28.7 cm	11.3 in
Diagonal	33.9 cm	13.4 in
Number of colors	Up to 16.8 million	
Contrast ratio	250:1 (typical)	
Brightness	180 nits (typical)	
Pixel resolution		
Pitch	0.279 × 0.279 mm	
Format	1280 × 800	
Configuration	RGB vertical stripe	
Backlight	Edge lit	
Character display	80 × 25	
Total power consumption	4.0 W	
Viewing angle	+/-40° horizontal, +120/-40° vertical (typical)	

Hard drive specifications

	320-GB*	250-GB*	160-GB*	120-GB*
Dimensions				
Height	9.5 mm	9.5 mm	9.5 mm	9.5 mm
Width	70 mm	70 mm	70 mm	70 mm
Weight	102 g	102 g	102 g	102 g
Interface type				
	SATA	SATA	SATA	SATA
Transfer rate				
Synchronous (maximum)	100 MB/sec	100 MB/sec	100 MB/sec	100 MB/sec
Security	ATA security	ATA security	ATA security	ATA security
Seek times (typical read, including setting)				
Single track	3 ms	3 ms	3 ms	3 ms
Average	13 ms	13 ms	13 ms	13 ms
Maximum	24 ms	24 ms	24 ms	24 ms
Logical blocks				
	645,126,482	500,586,425	312,581,808	237,937,274
Disk rotational speed			5400 rpm	
Operating temperature			5°C to 55°C (41°F to 131°F)	
NOTE: Certain restrictions and exclusions apply. Consult technical support for details.				
*1 GB = 1 billion bytes when referring to hard drive storage capacity. Accessible capacity is less. Actual drive specifications may differ slightly.				

DVD±RW and CD-RW Super Multi Double-Layer Combo Drive specifications

Applicable disc	Read:	Write:
	CD-DA, CD+(E)G, CD-MIDI, CD-TEXT, CD-ROM, CD-ROM XA, MIXED MODE CD, CD-I, CD-I Bridge (Photo-CD, Video CD), Multisession CD (Photo-CD, CD-EXTRA, Portfolio, CD-R, CD-RW), CD-R, CD-RW, DVD-ROM (DVD-5, DVD-9, DVD-10, DVD-18), DVD-R, DVD-RW, DVD+R, DVD+RW, DVD-RAM	CD-R and CD-RW DVD+R, DVD+RW, DVD-R, DVD-RW, DVD-RAM
Access time	CD	DVD
Random	< 175 ms	< 230 ms
Cache buffer	2 MB	
Data transfer rate		
24X CD-ROM	3,600 KB/sec	
8X DVD	10,800 KB/sec	
24X CD-R	3,600 KB/sec	
16X CD-RW	2,400 KB/sec	
8X DVD+R	10,800 KB/sec	
4X DVD+RW	5,400 KB/sec	
8X DVD-R	10,800 KB/sec	
4X DVD-RW	5,400 KB/sec	
2.4X DVD+R(9)	2,700 KB/sec	
5X DVD-RAM	6,750 KB/sec	
Transfer mode	Multiword DMA Mode	

DVD/CD-RW Combo Drive specifications

Applicable disc	Read:	Write:
	CD-DA, CD+(E)G, CD-MIDI, CD-TEXT, CDROM, CD-ROM XA, MIXED MODE CD, CD-I, CD-I Bridge (Photo-CD, Video CD), Multisession CD (Photo-CD, CD-EXTRA, Portfolio, CD-R, CDRW), CD-R, CD-RW, DVD-ROM (DVD-5, DVD-9, DVD-10, DVD-18), DVD-R, DVD-RW, DVD+R, DVD+RW, DVD-RAM	CD-R and CD-RW
Access time	CD	DVD
Random	< 110 ms	< 130 ms
Cache buffer	2 MB	
Data transfer rate		
24X CD-ROM	3,600 KB/sec	
8X DVD	3,600 KB/sec	
24X CD-R	3,600 KB/sec	
24X CD-RW	3,600 KB/sec	
Transfer mode	Multiword DMA mode 2	

System DMA specifications

Hardware DMA	System function
DMA0	Not applicable
DMA1*	Not applicable
DMA2*	Not applicable
DMA3	Not applicable
DMA4	Direct memory access controller
DMA5*	Available for PC Card
DMA6	Not assigned
DMA7	Not assigned

*PC Card controller can use DMA 1, 2, or 5.

System memory map specifications

Size	Memory address	System function
640 KB	00000000-0009FFFF	Base memory
128 KB	000A0000-000BFFFF	Video memory
48 KB	000C0000-000CBFFF	Video BIOS
160 KB	000C8000-000E7FFF	Unused
64 KB	000E8000-000FFFFF	System BIOS
15 MB	00100000-00FFFFFF	Extended memory
58 MB	04800000-07FFFFFF	Super extended memory
58 MB	04800000-07FFFFFF	Unused
2 MB	08000000-080FFFFF	Video memory (direct access)
4 GB	08200000-FFFFFFF	Unused
64 KB	FFFF0000-FFFFFFFF	System BIOS

System interrupt specifications

Hardware IRQ	System function
IRQ0	System timer
IRQ1	Standard 101-/102-Key or Microsoft® Natural Keyboard
IRQ2	Cascaded
IRQ3	Intel 82801DB/DBM USB2 Enhanced Host Controller—24CD
IRQ4	COM1
IRQ5*	Conexant AC—Link Audio Intel 82801DB/DBM SMBus Controller—24C3 Data Fax Modem with SmartCP
IRQ6	Diskette drive
IRQ7*	Parallel port
IRQ8	System CMOS/real-time clock
IRQ9*	Microsoft ACPI-compliant system
IRQ10*	Intel USB UHCI controller—24C2 Intel 82852/82855 GM/GME Graphic Controller Realtek RTL8139 Family PCI Fast Ethernet Controller
IRQ11	Intel USB EHCI controller—24CD Intel USB UHCI controller—24C4 Intel USB UHCI controller—24C7 Intel Pro/Wireless 2200BG TI OHCI 1394 host controller TI PCI1410 CardBus controller
IRQ12	Synaptics PS/2 TouchPad
IRQ13	Numeric data processor
IRQ14	Primary IDE channel
IRQ15	Secondary IDE channel

*Default configuration; audio possible configurations are IRQ5, IRQ7, IRQ9, IRQ10, or none.

NOTE: PC Cards may assert IRQ3, IRQ4, IRQ5, IRQ7, IRQ9, IRQ10, IRQ11, or IRQ15. Either the infrared or the serial port may assert IRQ3 or IRQ4.

System I/O address specifications

I/O address (hex)	System function (shipping configuration)
000 - 00F	DMA controller no. 1
010 - 01F	Unused
020 - 021	Interrupt controller no. 1
022 - 024	Opti chipset configuration registers
025 - 03F	Unused
02E - 02F	87334 "Super I/O" configuration for CPU
040 - 05F	Counter/timer registers
044 - 05F	Unused
060	Keyboard controller
061	Port B
062 - 063	Unused
064	Keyboard controller
065 - 06F	Unused
070 - 071	NMI enable/RTC
072 - 07F	Unused
080 - 08F	DMA page registers
090 - 091	Unused
092	Port A
093 - 09F	Unused
0A0 - 0A1	Interrupt controller no. 2
I/O Address (hex)	System function (shipping configuration)
0A2 - 0BF	Unused
0C0 - 0DF	DMA controller no. 2
0E0 - 0EF	Unused
0F0 - 0F1	Coprocessor busy clear/reset
0F2 - 0FF	Unused
100 - 16F	Unused
170 - 177	Secondary fixed disk controller
178 - 1EF	Unused
1F0 - 1F7	Primary fixed disk controller
1F8 - 200	Unused
201	JoyStick (decoded in ESS1688)
202 - 21F	Unused

I/O address (hex)	System function (shipping configuration)
220 - 22F	Entertainment audio
230 - 26D	Unused
26E - 26	Unused
278 - 27F	Unused
280 - 2AB	Unused
2A0 - 2A7	Unused
2A8 - 2E7	Unused
2E8 - 2EF	Reserved serial port
2F0 - 2F7	Unused
2F8 - 2FF	Infrared port
300 - 31F	Unused
320 - 36F	Unused
370 - 377	Secondary diskette drive controller
378 - 37F	Parallel port (LPT1/default)
380 - 387	Unused
388 - 38B	FM synthesizer—OPL3
38C - 3AF	Unused
3B0 - 3BB	VGA
3BC - 3BF	Reserved (parallel port/no EPP support)
3C0 - 3DF	VGA
3E0 - 3E1	PC Card controller in CPU
3E2 - 3E3	Unused
3E8 - 3EF	Internal modem
3F0 - 3F7	“A” diskette controller
3F8 - 3FF	Serial port (COM1/default)
CF8 - CFB	PCI configuration index register (PCIDIVO-1)
CFC - CFF	PCI configuration data register (PCIDIVO-1)

7 Screw listing

This section provides specification and reference information for the screws and screw locks used in the computer. All screws and screw locks listed in this section are available in the Screw Kit, spare part number 468822-001 for dv3000 models, 502462-001 for dv3500 models, and the Display Screw Kit, spare part number 468803-001 for use in dv3000 models, 500958-001 for use in dv3500 models with an LCD display, and 502364-001 for models with an LED display.

Phillips PM3.0×4.0 screw

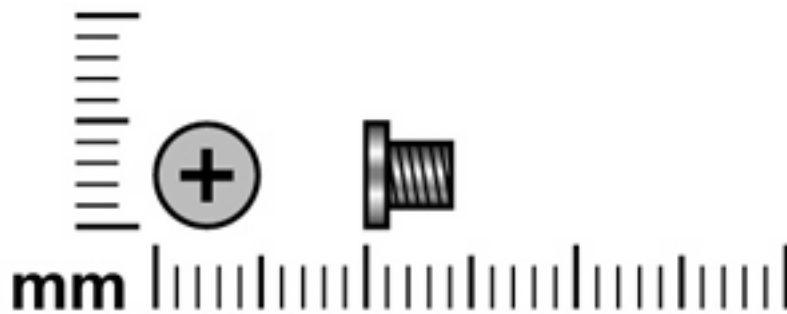

Color	Quantity	Length	Thread	Head diameter
Silver	4	4.0 mm	3.0 mm	5.0 mm

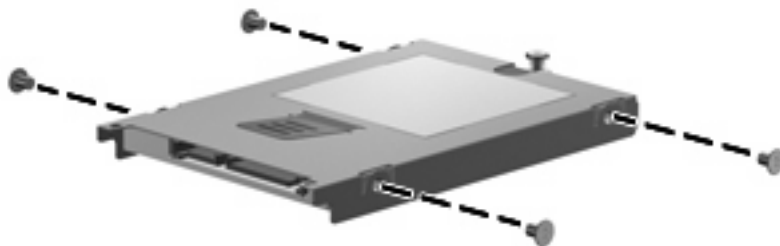

Where used: 4 screws that secure the hard drive bracket to the hard drive

Phillips PM2.5×6.0 captive screw

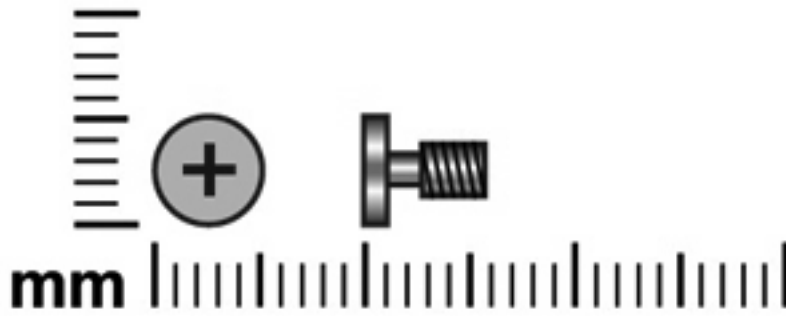

Color	Quantity	Length	Thread	Head diameter
Black	5	6.0 mm	2.5 mm	5.0 mm

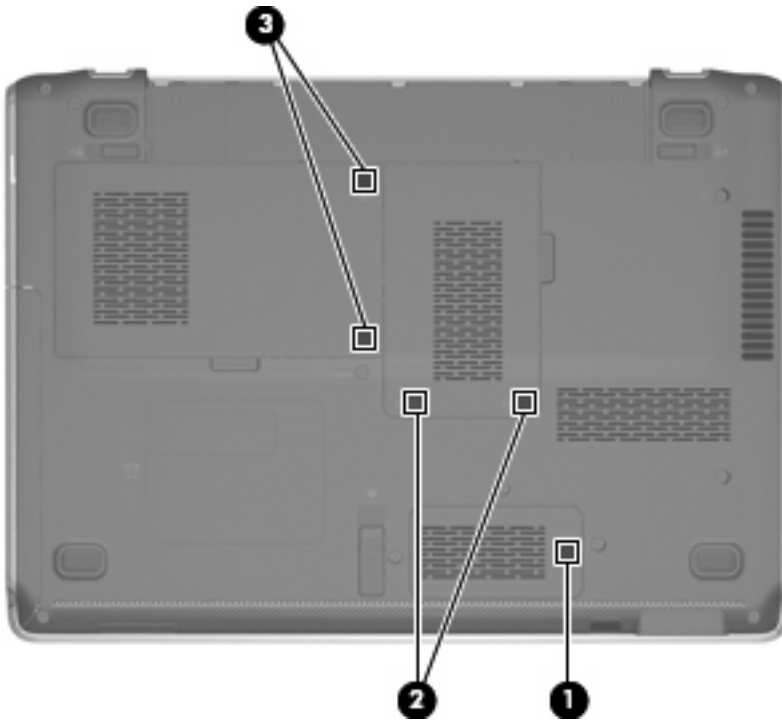

Where used:

- (1) One captive screw (secured by a C-clip) that secures the WLAN compartment cover to the computer
- (2) Two captive screws (secured by C-clips) that secure the memory module compartment cover to the computer
- (3) Two captive screws (secured by C-clips) that secure the hard drive bay cover to the computer

Black Phillips PM2.5×4.0 screw

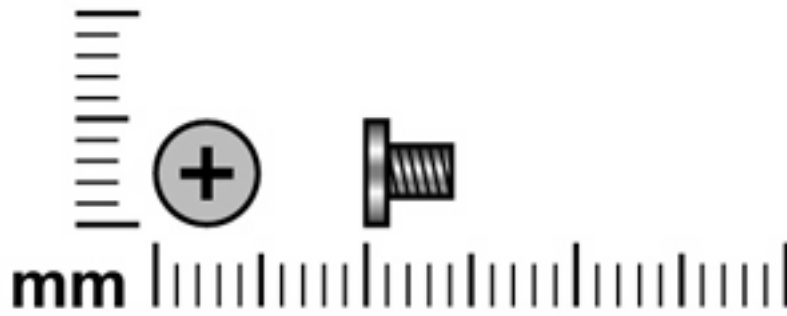

Color	Quantity	Length	Thread	Head diameter
Black	4	4.0 mm	2.0 mm	4.5 mm

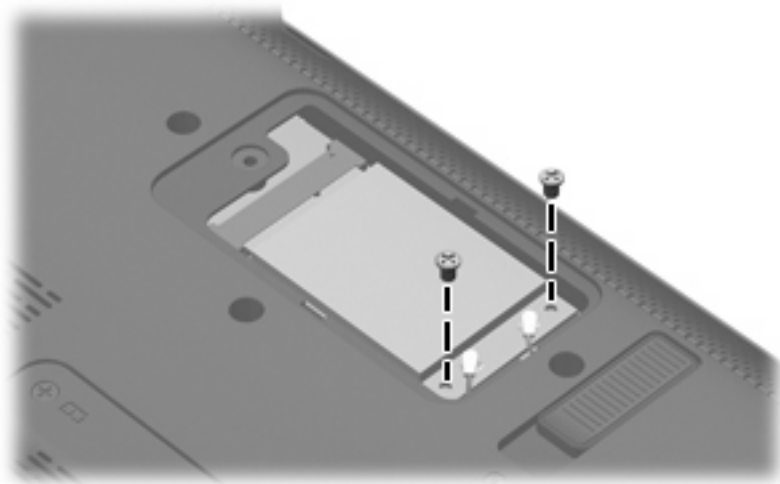

Where used: 2 screws that secure the WLAN module to the system board

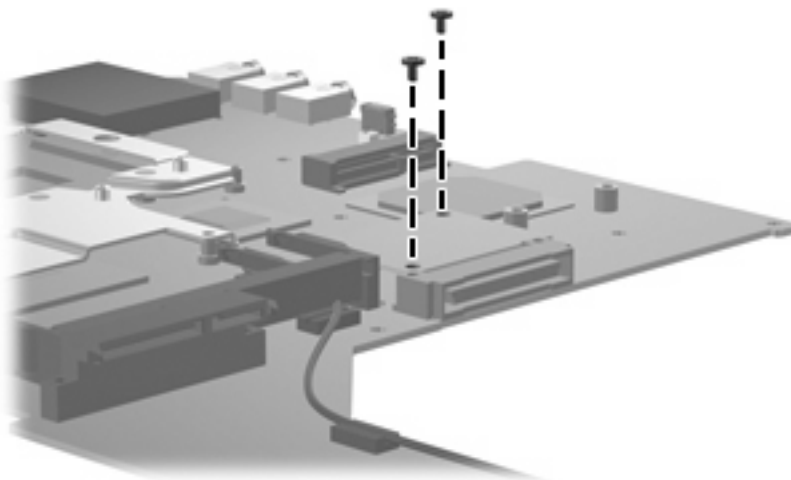

Where used: 2 screws that secure the modem module to the computer

Phillips PM2.5×11.0 captive screw

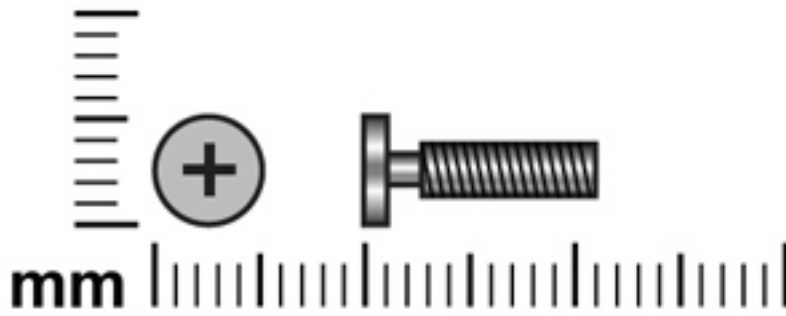

Color	Quantity	Length	Thread	Head diameter
Black	1	11.0 mm	2.5 mm	5.0 mm

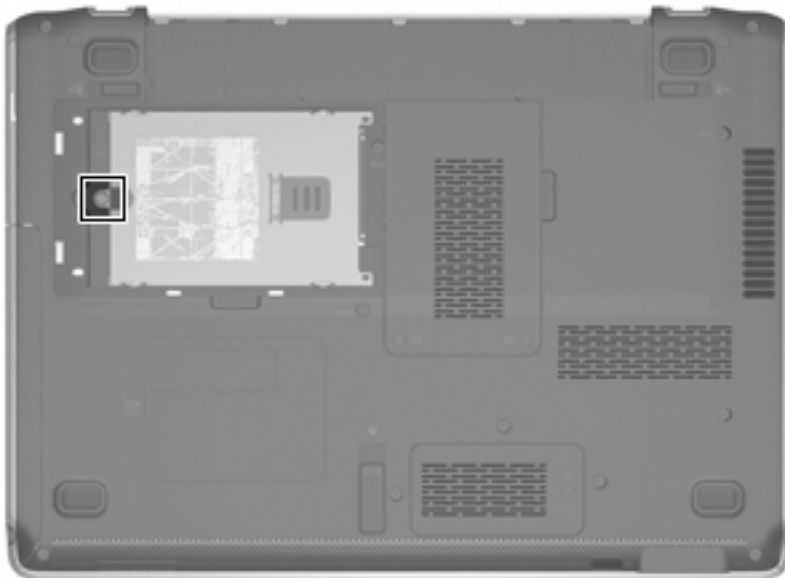

Where used: One captive screw (secured in the hard drive bracket housing) that secures the hard drive to the computer

Phillips PM2.0×4.0 screw

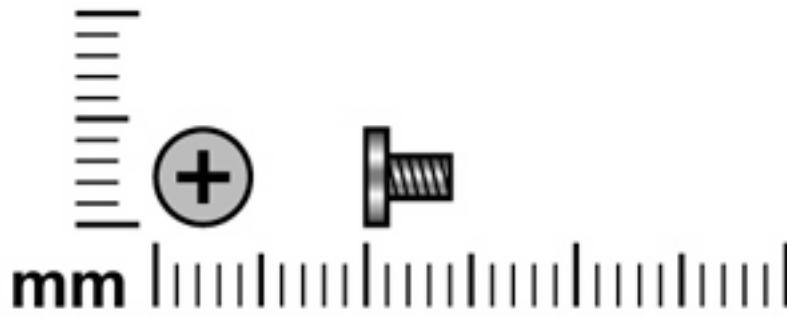

Color	Quantity	Length	Thread	Head diameter
Black	10	4.0 mm	2.0 mm	4.5 mm

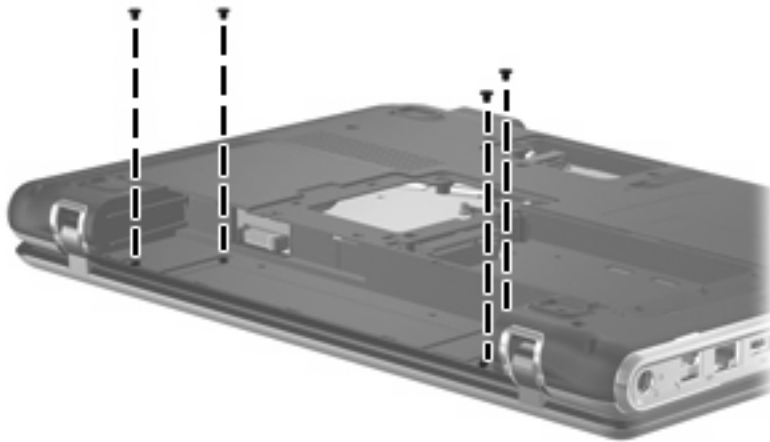

Where used: 4 screws that secure the switch cover to the computer

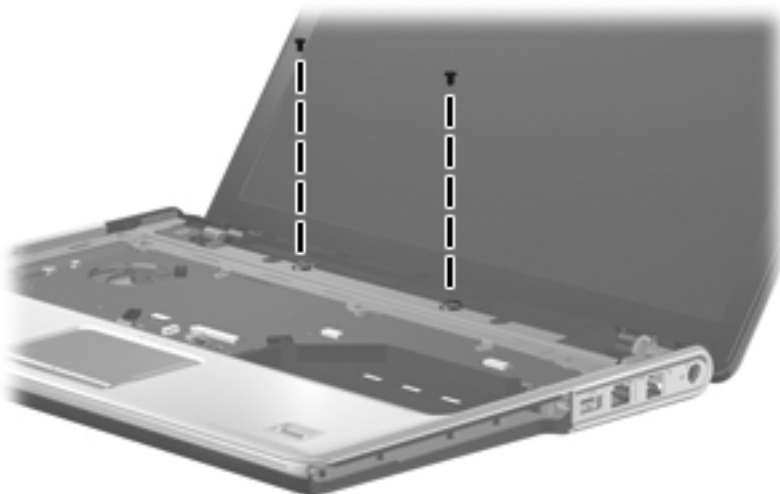

Where used: 2 screws that secure the top cover to the base enclosure

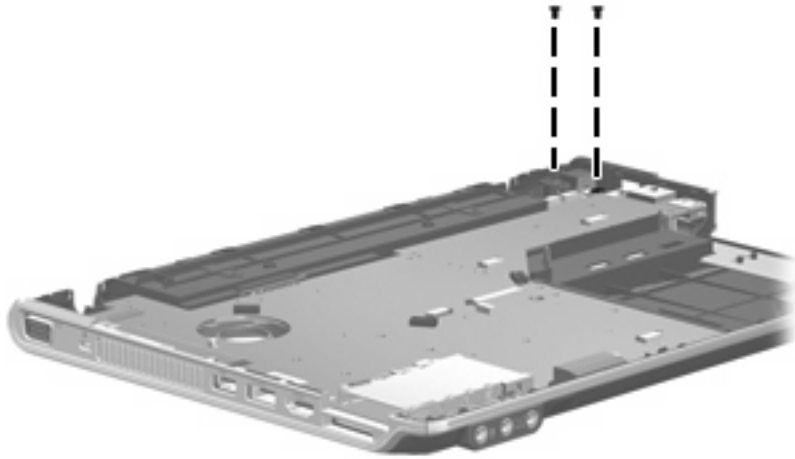

Where used: 2 screws that secure the power connector bracket to the base enclosure

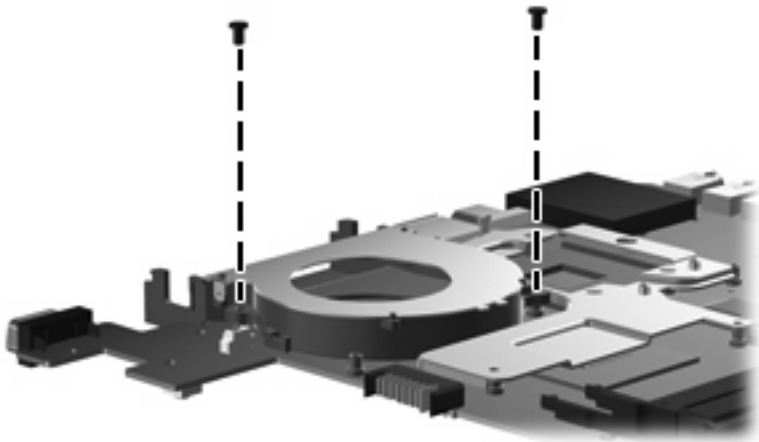

Where used: 2 screws that secure the fan to the base enclosure

Phillips PM2.5×7.0 screw

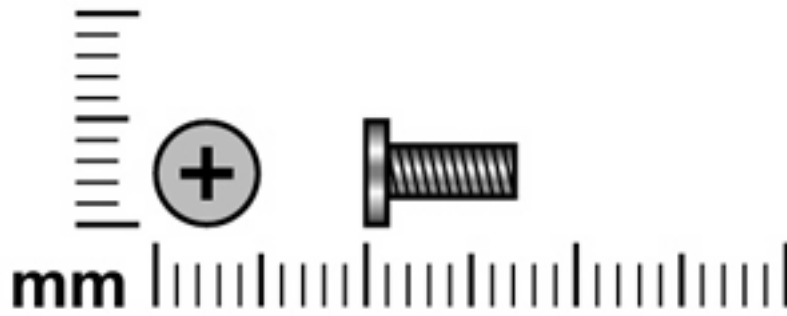

Color	Quantity	Length	Thread	Head diameter
Black	22	7.0 mm	2.5 mm	5.0 mm

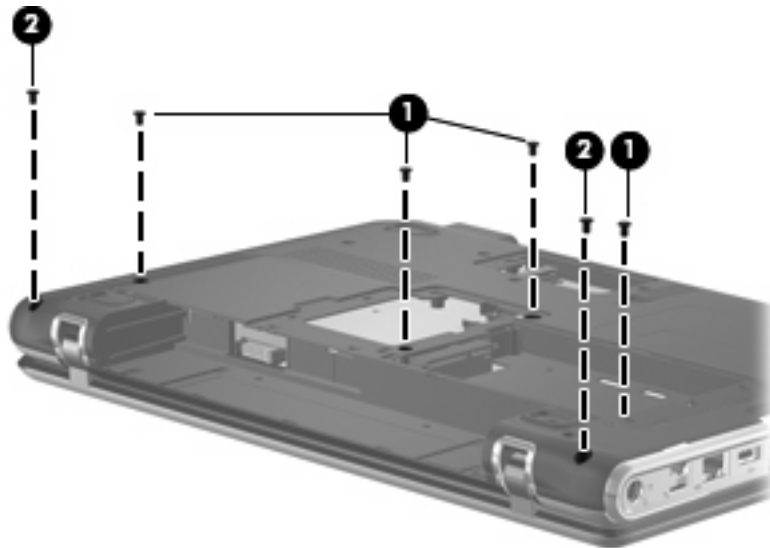

Where used:

- (1) Four screws that secure the keyboard to the computer
- (2) Two screws that secure the switch cover to the computer

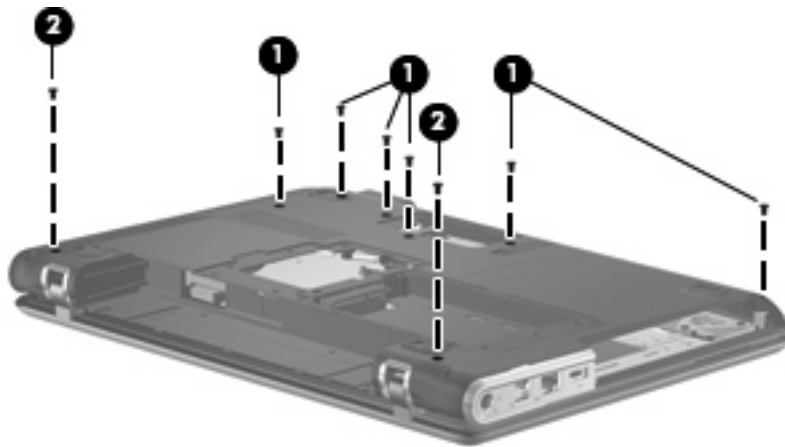

Where used:

(1) Six screws that secure the top cover to the base enclosure

(2) Two screws that secure the display assembly to the base enclosure

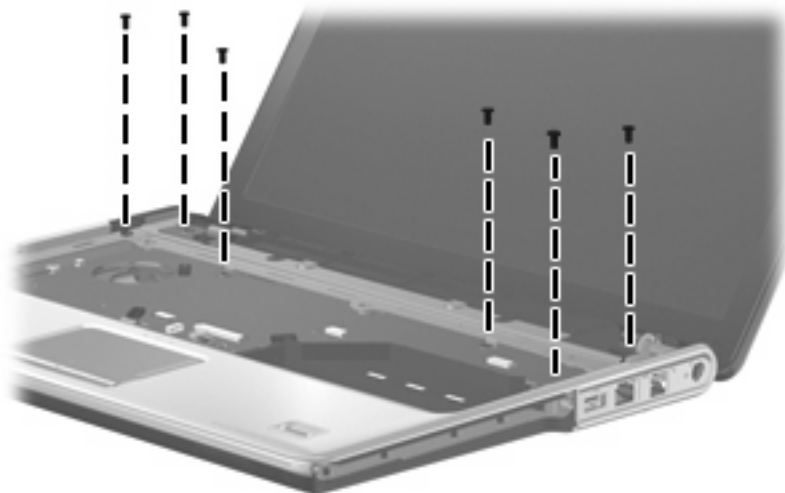

Where used: 6 screws that secure the top cover to the base enclosure

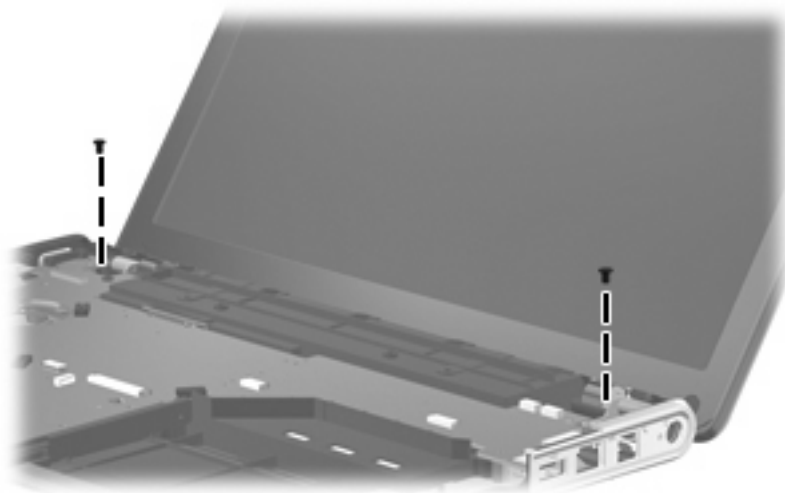

Where used: Two screws that secure the display assembly to the base enclosure

Phillips PM2.5×5.0 screw

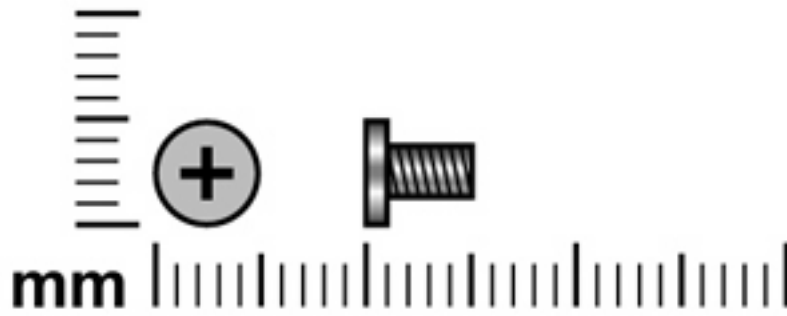

Color	Quantity	Length	Thread	Head diameter
Black	10	5.0 mm	2.5 mm	5.0 mm

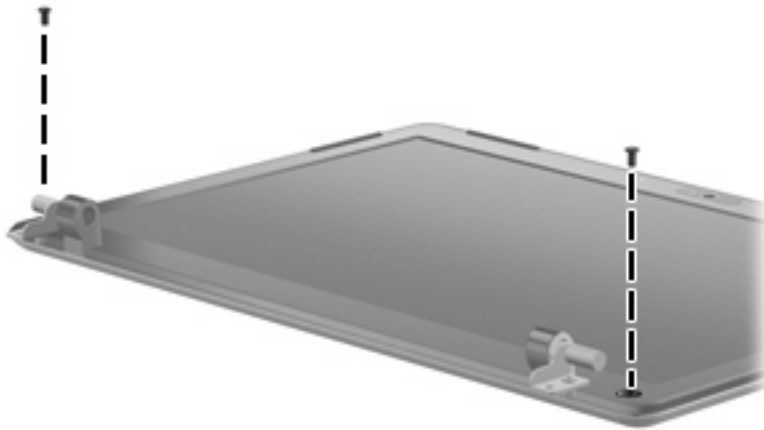

Where used: 2 screws that secure the display bezel to the display enclosure



Where used: 6 screws that secure the display panel to the display enclosure



Where used: 2 screws that secure the system board to the base enclosure

Phillips PM2.0×3.0 captive screw

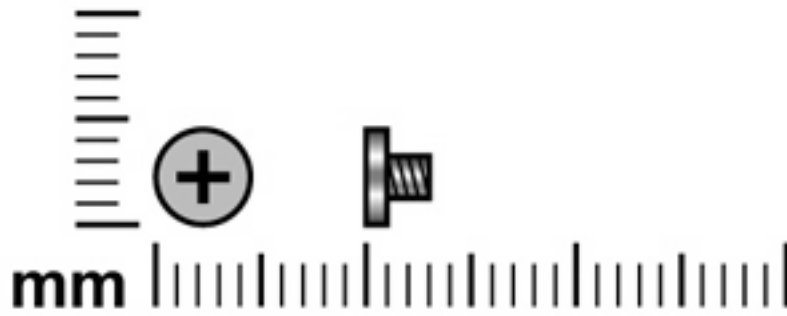

Color	Quantity	Length	Thread	Head diameter
Silver	9	3.0 mm	2.0 mm	4.5 mm

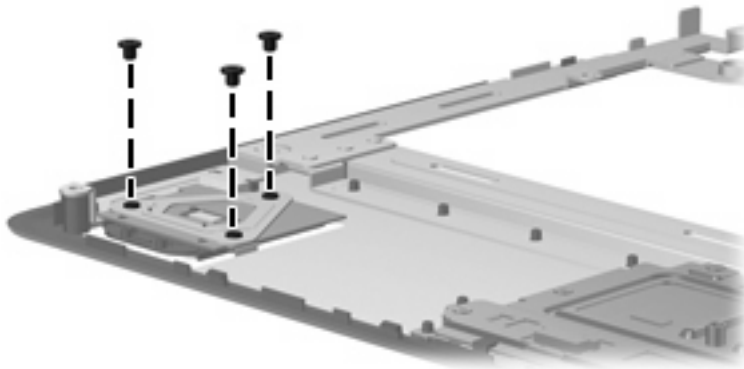

Where used: 3 screws that secure the fingerprint reader board and bracket to the top cover

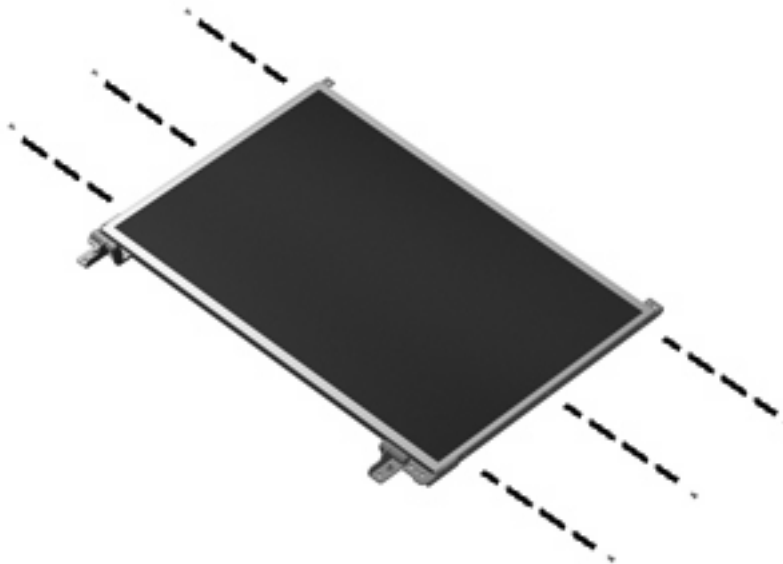

Where used: 6 screws that secure the display hinges to the display panel

Silver Phillips PM2.5×4.0 screw

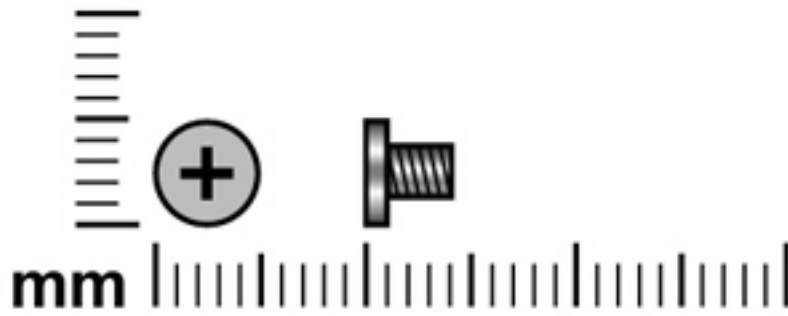

Color	Quantity	Length	Thread	Head diameter
Silver	1	5.0 mm	2.5 mm	5.0 mm

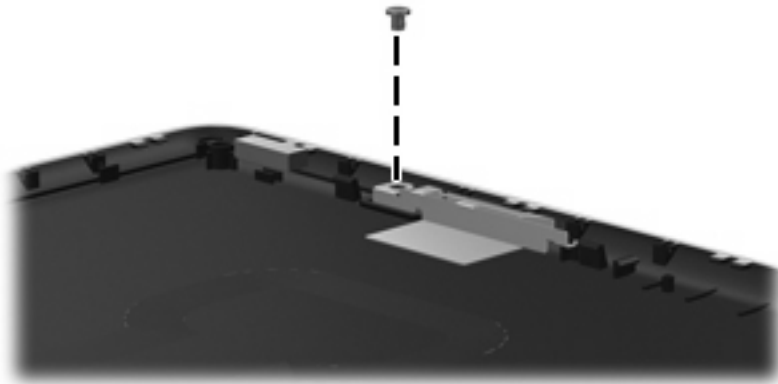

Where used: One screw that secures the left wireless antenna transceiver to the display enclosure

Phillips PM2.0×5.0 captive screw

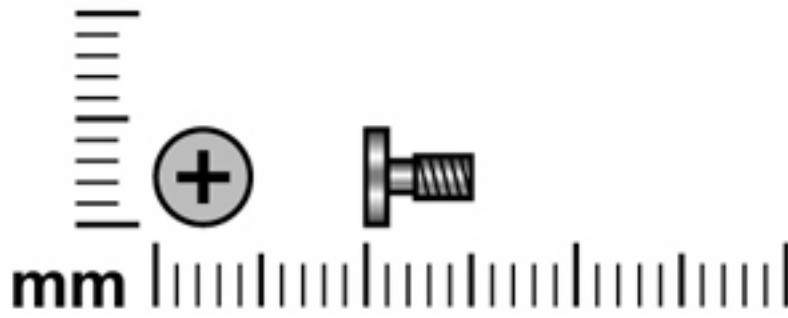

Color	Quantity	Length	Thread	Head diameter
Black	2	5.0 mm	2.0 mm	5.0 mm

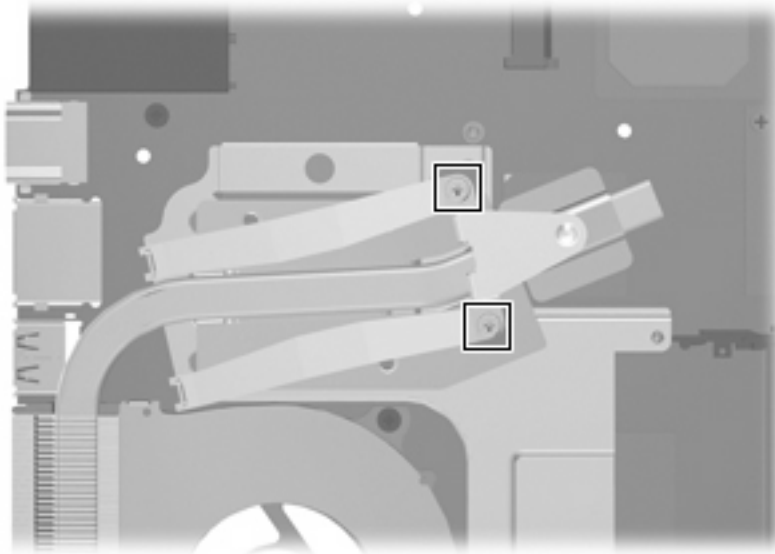

Where used: 2 captive screws (secured by C-clips) that secure the heat sink retention clip to the heat sink

8 Backup and recovery

Recovering system information

Recovery after a system failure is as complete as your most current backup. HP recommends that you create recovery discs immediately after software setup. As you add new software and data files, you should continue to back up your system on a regular basis to maintain a reasonably current backup.

Tools provided by the operating system and HP Recovery Manager software are designed to help you with the following tasks for safeguarding your information and restoring it in case of a system failure:

- Creating a set of recovery discs (Recovery Manager software feature). Recovery discs are used to start up (boot) your computer and restore the operating system and software programs to factory settings in case of system failure or instability.
- Backing up your information regularly to protect your important system files.
- Creating system restore points (operating system feature). System restore points allow you to reverse undesirable changes to your computer by restoring the computer to an earlier state.
- Recovering a program or driver (Recovery Manager software feature). This feature helps you reinstall a program or driver without performing a full system recovery.
- Performing a full system recovery (Recovery Manager software feature). With Recovery Manager, you can recover your full factory image if you experience system failure or instability. Recovery Manager works from a dedicated recovery partition (select models only) on the hard drive or from recovery discs you create.

Creating recovery discs

 **NOTE:** HP recommends that you create recovery discs to be sure that you can restore your system to its original factory state if you experience serious system failure or instability. Create these discs after setting up the computer for the first time.

NOTE: Handle these discs carefully and keep them in a safe place. The software allows the creation of only one set of recovery discs.

Note the following guidelines before creating recovery discs:

- You will need high-quality DVD-R, double-layer DVD-R, DVD+R, double-layer DVD+R, BD-R (writable Blu-ray), or CD-R discs. All these discs are purchased separately. DVDs and BDs have a much higher capacity than CDs. If you use CDs, up to 20 discs may be required, whereas only a few DVDs or BDs are required.



NOTE: Read-write discs, such as CD-RW, DVD±RW, double-layer DVD±RW, and BD-RE (rewritable Blu-ray) discs, are not compatible with the Recovery Manager software.

- The computer must be connected to AC power during this process.
- Only one set of recovery discs can be created per computer.
- Number each disc before inserting it into the computer optical drive.
- If necessary, you can exit the program before you have finished creating the recovery discs. The next time you open Recovery Manager, you will be prompted to continue the disc creation process.

To create a set of recovery discs:

1. Select **Start > All Programs > Recovery Manager > Recovery Manager**.

Recovery Manager opens.

2. Click **Advanced Options**.



NOTE: If you are operating the computer on battery power, you will be prompted to connect to AC power before you can go to the next step.

3. Click **Recovery disc creation**, and then click **Next**.
4. Follow the on-screen instructions.

Backing up your information

When to back up

- On a regularly scheduled basis



NOTE: Set reminders to back up your information periodically.

- Before the computer is repaired or restored
- Before you add or modify hardware or software

Backup suggestions

- Create a set of recovery discs using Recovery Manager.
- Create system restore points using the Windows® System Restore feature, and periodically copy them to disc.
- Store personal files in the Documents folder and back up this folder periodically.
- Back up templates stored in their associated programs.
- Save customized settings in a window, toolbar, or menu bar by taking a screen shot of your settings. The screen shot can be a time-saver if you have to reset your preferences.

To copy the screen and paste it into a word-processing document, follow these steps:

- a. Display the screen.
- b. Copy the screen:
 - To copy only the active window, press **alt+fn+prt sc**.
 - To copy the entire screen, press **fn+prt sc**.
- c. Open a word-processing document, and then select **Edit > Paste**.

Using system restore points

When you back up your system, you are creating a system restore point. A system restore point allows you to save and name a snapshot of your hard drive at a specific point in time. You can then recover back to that point if you want to reverse subsequent changes made to your system.

 **NOTE:** Recovering to an earlier restore point does not affect data files saved or e-mails created since the last restore point.

You also can create additional restore points to provide increased protection for your system files and settings.

When to create restore points

- Before you add or extensively modify software or hardware
- Periodically, whenever the system is performing optimally

 **NOTE:** If you revert to a restore point and then change your mind, you can reverse the restoration.

Create a system restore point

1. Select **Start > Control Panel > System and Maintenance > System**.
2. In the left pane, click **System Protection**.
3. Click the **System Protection** tab.
4. Under **Automatic restore points**, select the disk for which you want to create a restore point.
5. Click **Create**.

The System Protection window opens.

6. Follow the on-screen instructions.

Restore to a previous date and time

To revert to a restore point (created at a previous date and time), when the computer was functioning optimally, follow these steps:

1. Select **Start > Control Panel > System and Maintenance > System**.
2. In the left pane, click **System protection**.
3. Click the **System Protection** tab.
4. Click the **System Restore** button, and then click **Next**.

The System Restore window opens.

5. Follow the on-screen instructions.

Performing a recovery

 **NOTE:** You can recover only files that you have previously backed up. HP recommends that you use HP Recovery Manager to create an entire drive backup as soon as you set up your computer.

Recovery Manager software allows you to repair or restore the system if you experience system failure or instability. Recovery Manager works from recovery discs that you create or from a dedicated recovery partition (select models only) on the hard drive. However, if your computer includes a solid-state drive (SSD), you may not have a recovery partition. If that is the case, recovery discs have been included with your computer. Use these discs to recover your operating system and software.

 **NOTE:** Windows has its own built-in repair features, such as System Restore and driver roll-back capabilities. If you have not already tried these features, try them before using Recovery Manager.

NOTE: Recovery Manager recovers only software that was preinstalled at the factory. Software not provided with this computer must be downloaded from the manufacturer's Web site or reinstalled from the disc provided by the manufacturer.

Recovering from the recovery discs

To restore the system from the recovery discs:

1. Back up all personal files.
2. Insert the first recovery disc into the optical drive and restart the computer.
3. Follow the on-screen instructions.

Recovering from the dedicated recovery partition (select models only)

 **NOTE:** If your computer includes an SSD, you may not have a recovery partition. You will not be able to recover using this procedure. Recovery discs have been included for computers that do not have a partition. Use these discs to recover your operating system and software.

On some models, you can perform a recovery from the partition on the hard drive from either the Start button or **f11**. This restores the computer to its factory condition.

To restore the system from the partition, follow these steps:

1. Access Recovery Manager in either of the following ways:
 - Select **Start > All Programs > Recovery Manager > Recovery Manager**.
 - or–
 - Restart the computer and press **f11** while the “Press <F11> for recovery” message is displayed on the screen. Then select **Recovery Manager**.

Recovery Manager opens.

2. Click **Advanced Options**.
3. Click **System recovery**, and then click **Next**.
4. Follow the on-screen instructions.

9 Connector pin assignments

Audio-out (headphone)

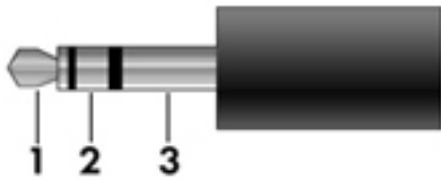

Pin	Signal
1	Audio out, left channel
2	Audio out, right channel
3	Ground

Audio-in (microphone)

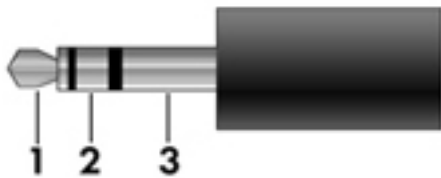

Pin	Signal
1	Audio signal in
2	Audio signal in
3	Ground

External monitor

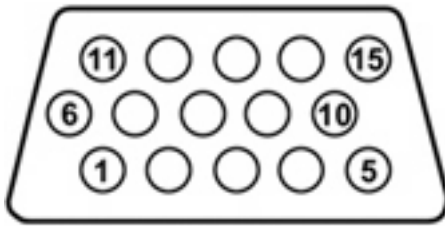

Pin	Signal
1	Red analog
2	Green analog
3	Blue analog
4	Not connected
5	Ground
6	Ground analog
7	Ground analog
8	Ground analog
9	+5 VDC
10	Ground
11	Monitor detect
12	DDC 2B data
13	Horizontal sync
14	Vertical sync
15	DDC 2B clock

RJ-11 (modem)

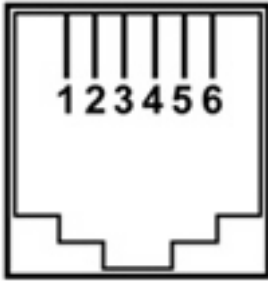

Pin	Signal
1	Unused
2	Tip
3	Ring
4	Unused
5	Unused
6	Unused

RJ-45 (network)

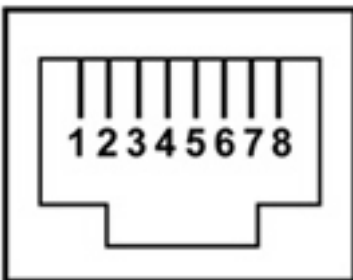

Pin	Signal
1	Transmit +
2	Transmit -
3	Receive +
4	Unused
5	Unused
6	Receive -
7	Unused
8	Unused

Universal Serial Bus

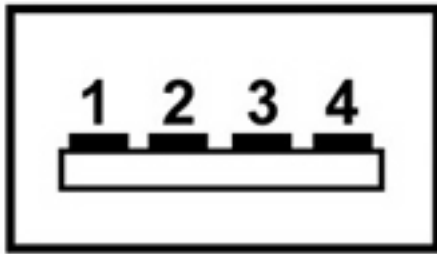

Pin	Signal
1	+5 VDC
2	Data -
3	Data +
4	Ground

10 Power cord set requirements

The wide range input feature of the computer permits it to operate from any line voltage from 100 to 120 volts AC or from 220 to 240 volts AC.

The 3-conductor power cord set included with the computer meets the requirements for use in the country or region where the equipment is purchased.

Power cord sets for use in other countries or regions must meet the requirements of the country or region where the computer is used.

Requirements for all countries or regions

The requirements listed below are applicable to all countries or regions:

- The length of the power cord set must be at least 1.5 m (5.0 ft) and no more than 2.0 m (6.5 ft).
- All power cord sets must be approved by an acceptable accredited agency responsible for evaluation in the country or region where the power cord set will be used.
- The power cord sets must have a minimum current capacity of 10 amps and a nominal voltage rating of 125 or 250 V AC, as required by each country or region's power system.
- The appliance coupler must meet the mechanical configuration of an EN 60 320/IEC 320 Standard Sheet C13 connector for mating with the appliance inlet on the back of the computer.

Requirements for specific countries or regions

Country/region	Accredited agency	Applicable note number
Australia	EANSW	1
Austria	OVE	1
Belgium	CEBC	1
Canada	CSA	2
Denmark	DEMKO	1
Finland	FIMKO	1
France	UTE	1
Germany	VDE	1
Italy	IMQ	1
Japan	METI	3
Korea	EK	4
The Netherlands	KEMA	1
Norway	NEMKO	1
The People's Republic of China	CCC	5
Sweden	SEMKO	1
Switzerland	SEV	1
Taiwan	BSMI	4
The United Kingdom	BSI	1
The United States	UL	2

1. The flexible cord must be Type HO5VV-F, 3-conductor, 1.0-mm² conductor size. Power cord set fittings (appliance coupler and wall plug) must bear the certification mark of the agency responsible for evaluation in the country or region where it will be used.
2. The flexible cord must be Type SPT-3 or equivalent, No. 18 AWG, 3-conductor. The wall plug must be a two-pole grounding type with a NEMA 5-15P (15 A, 125 V) or NEMA 6-15P (15 A, 250 V) configuration.
3. The appliance coupler, flexible cord, and wall plug must bear a "T" mark and registration number in accordance with the Japanese Dentori Law. The flexible cord must be Type VCT or VCTF, 3-conductor, 1.00-mm² conductor size. The wall plug must be a two-pole grounding type with a Japanese Industrial Standard C8303 (7 A, 125 V) configuration.
4. The flexible cord must be Type RVV, 3-conductor, 0.75-mm² conductor size. Power cord set fittings (appliance coupler and wall plug) must bear the certification mark of the agency responsible for evaluation in the country or region where it will be used.
5. The flexible cord must be Type VCTF, 3-conductor, 0.75-mm² conductor size. Power cord set fittings (appliance coupler and wall plug) must bear the certification mark of the agency responsible for evaluation in the country or region where it will be used.

11 Recycling

Battery

When a battery has reached the end of its useful life, do not dispose of the battery in general household waste. Follow the local laws and regulations in your area for computer battery disposal.

Display

- ⚠ **WARNING!** The backlight contains mercury. Caution must be exercised when removing and handling the backlight to avoid damaging this component and causing exposure to the mercury.
- ⚠ **CAUTION:** The procedures in this appendix can result in damage to display components. The only components intended for recycling purposes are the liquid crystal display (LCD) panel and the backlight. Careful handling must be exercised when removing these components.
- 📄 **NOTE: Materials Disposal.** This HP product contains mercury in the backlight in the display assembly that might require special handling at end-of-life. Disposal of mercury may be regulated because of environmental considerations. For disposal or recycling information, contact your local authorities, or see the Electronic Industries Alliance (EIA) Web site at <http://www.eiae.org>.

This section provides disassembly instructions for the display assembly. The display assembly must be disassembled to gain access to the backlight **(1)** and the liquid crystal display (LCD) panel **(2)**.



- 📄 **NOTE:** The procedures provided in this appendix are general disassembly instructions. Specific details, such as screw sizes, quantities, and locations, and component shapes and sizes, can vary from one computer model to another.

Perform the following steps to disassemble the display assembly:

1. Remove all screw covers (1) and screws (2) that secure the display bezel to the display assembly.

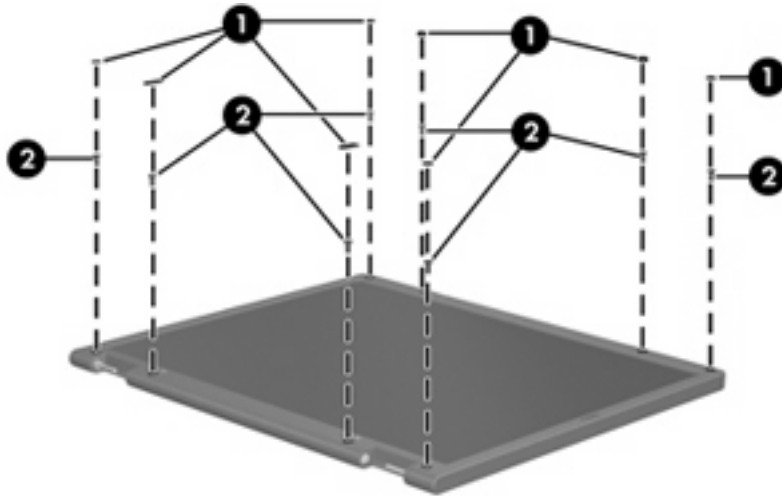

2. Lift up and out on the left and right inside edges (1) and the top and bottom inside edges (2) of the display bezel until the bezel disengages from the display assembly.

3. Remove the display bezel (3).

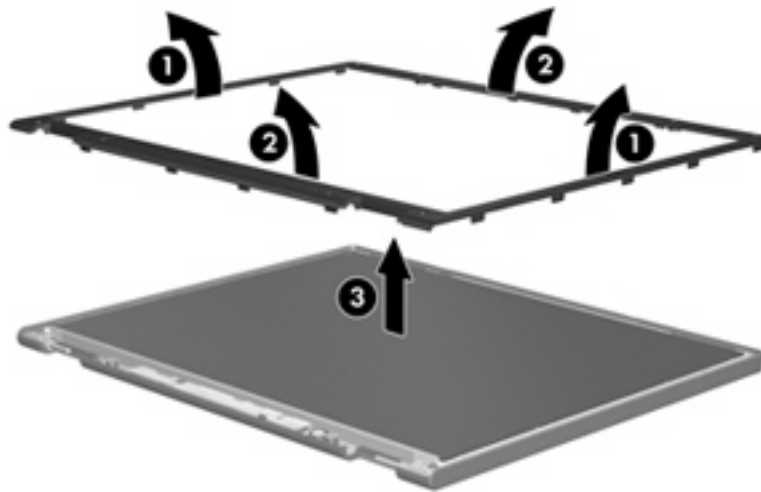

4. Disconnect all display panel cables (1) from the display inverter and remove the inverter (2).

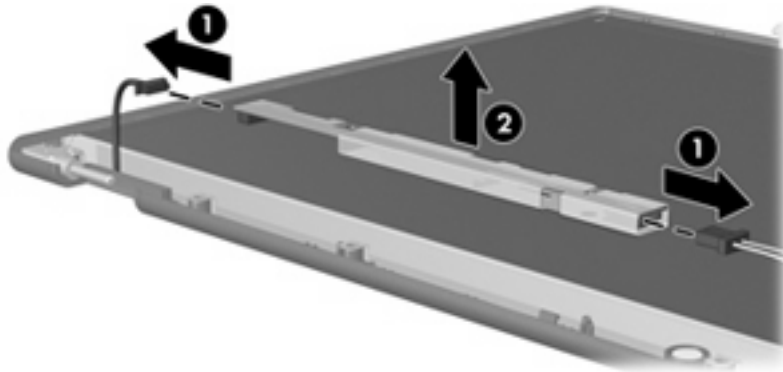

5. Remove all screws (1) that secure the display panel assembly to the display enclosure.
6. Remove the display panel assembly (2) from the display enclosure.

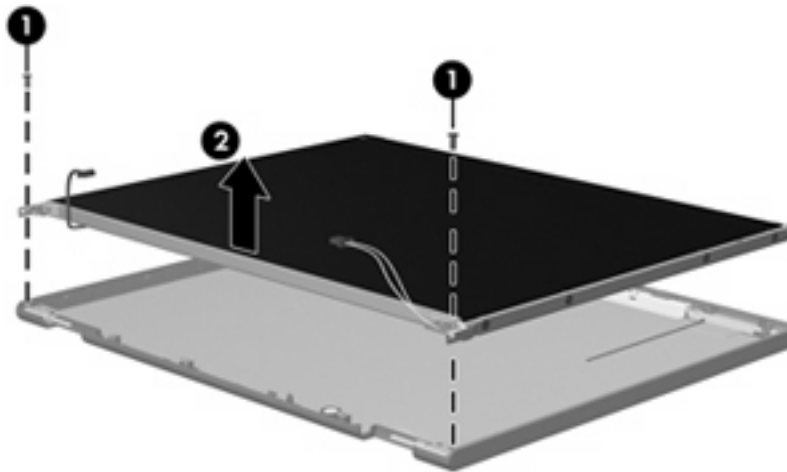

7. Turn the display panel assembly upside down.
8. Remove all screws that secure the display panel frame to the display panel.

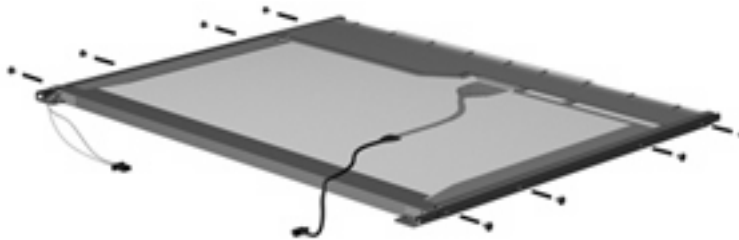

9. Use a sharp-edged tool to cut the tape (1) that secures the sides of the display panel to the display panel frame.

10. Remove the display panel frame (2) from the display panel.

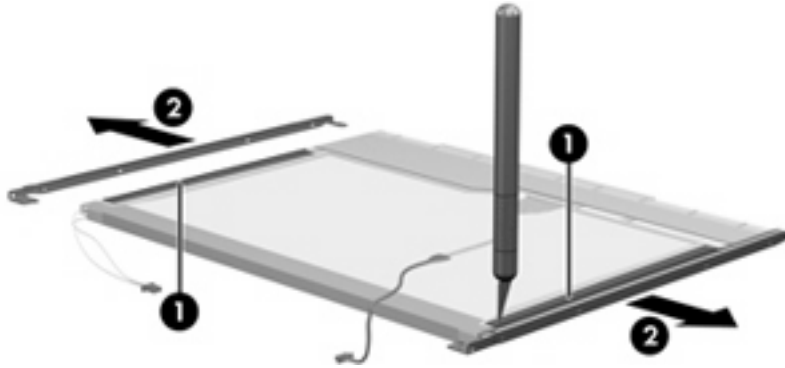

11. Remove the screws (1) that secure the backlight cover to the display panel.
12. Lift the top edge of the backlight cover (2) and swing it outward.

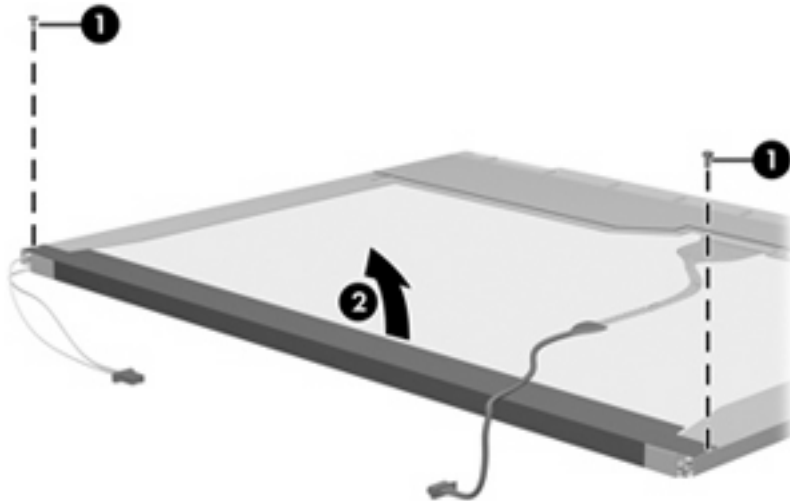

13. Remove the backlight cover.
14. Turn the display panel right-side up.

15. Remove the backlight cables (1) from the clip (2) in the display panel.

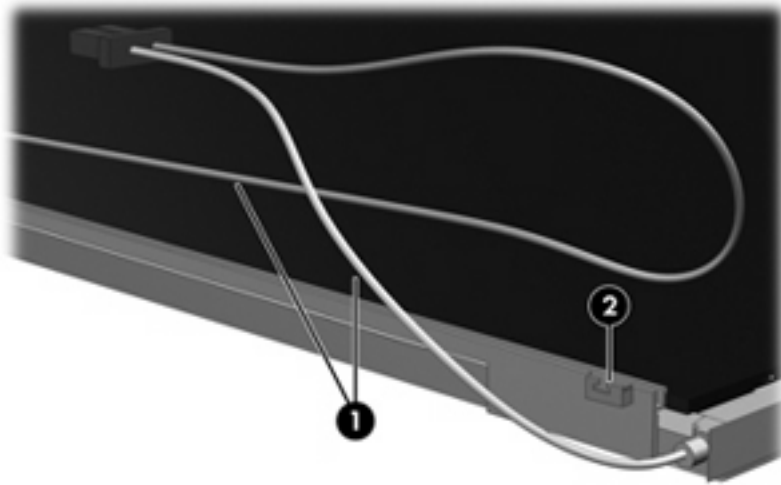

16. Turn the display panel upside down.
17. Remove the backlight frame from the display panel.

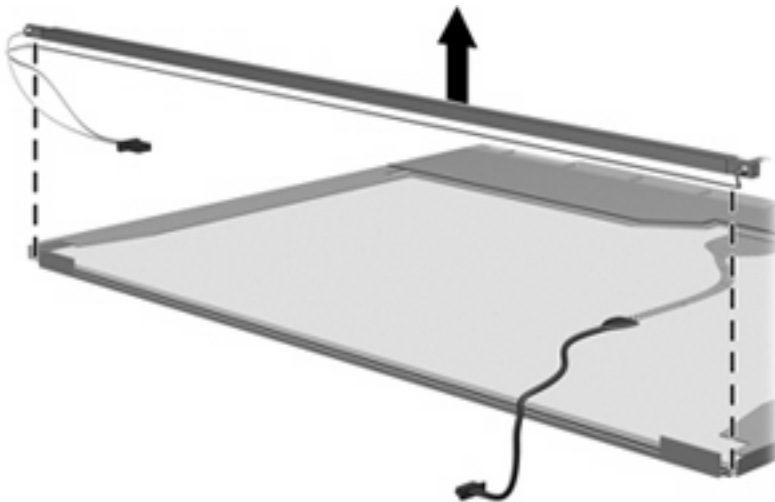

⚠ WARNING! The backlight contains mercury. Exercise caution when removing and handling the backlight to avoid damaging this component and causing exposure to the mercury.

18. Remove the backlight from the backlight frame.

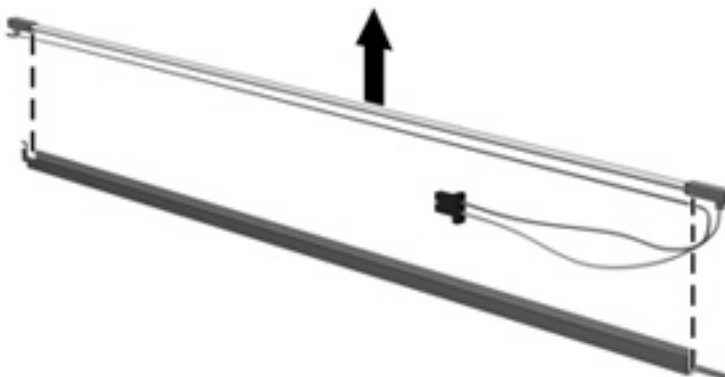

19. Disconnect the display cable (1) from the LCD panel.
20. Remove the screws (2) that secure the LCD panel to the display rear panel.
21. Release the LCD panel (3) from the display rear panel.
22. Release the tape (4) that secures the LCD panel to the display rear panel.

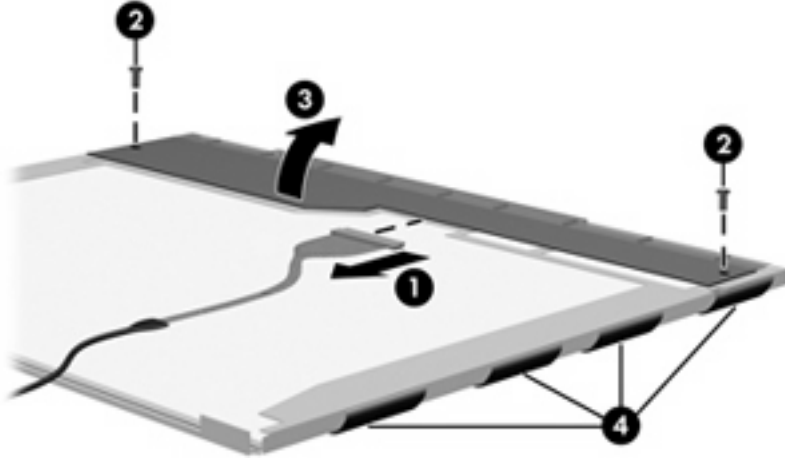

23. Remove the LCD panel.

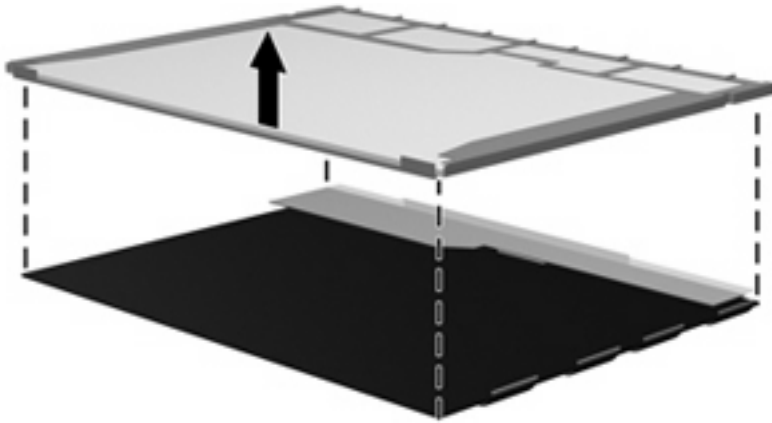

24. Recycle the LCD panel and backlight.

Index

Symbols/Numerics

1394 Power Saving 89

A

AC adapter light, identifying 12

AC adapter, spare part
number 28, 31

administrator password 89

antenna

illustrated 24

removal 68

spare part number 25, 31,
35

antennae 16

applications key, Windows 11

audio, product description 3

audio-in (microphone) jack,
identifying 12

audio-in jack, pin
assignments 118

audio-out (headphone) jacks,
identifying 12

audio-out jack, pin
assignments 118

B

backing up

customized window, toolbar,
and menu bar settings 115
personal files 115
templates 115

backup 114

backup suggestions 115

base enclosure, spare part
number 21, 32, 35

battery

removal 43

spare part numbers 21, 32,
34, 43

battery bay, identifying 14

battery light, identifying 8

battery release latches,
identifying 14

bays

battery 14

hard drive 14

Bluetooth module

removal 75

spare part number 20, 30,
75

boot options 90

boot order 90

button sound 89

buttons

media 9

next/fast forward 10

play/pause 10

power 9

previous/rewind 10

stop 10

TouchPad 6

TouchPad on/off 6

volume mute 9

wireless 10

C

Cable Kit, spare part number 32,
35

cables, service considerations 37

caps lock light, identifying 7

Card Reader Power Saving 89

changing the Setup Utility
language 87

chipset, product description 1

CMOS clearing 41

compartments

memory module 14

wireless module 14

components

bottom 14

display 15

front 6, 12

left-side 13

right-side 12

top 6

computer feet

locations 43

spare part number 43

computer specifications 91

connector pin assignments

audio-in 118

audio-out 118

external monitor 119

headphone 118

microphone 118

modem 120

monitor 119

network 120

RJ-11 120

RJ-45 120

Universal Serial Bus
(USB) 121

connector, power 12

connectors, service
considerations 37

D

Diagnostics menu 90

Digital Media Slot, identifying 13

diskette drive, precautions 37

display assembly

removal 63

spare part number 19, 32,
34

spare part numbers 63

display bezel

illustrated 24

removal 65

spare part number 24, 31,
35, 66

- Display Cable Kit, spare part number 25, 31, 35, 68
- display components
 - illustrated 24
 - recycling 124
 - spare part numbers 24
- display enclosure
 - illustrated 24
 - spare part number 25, 31, 35
- display hinge
 - illustrated 24
 - removal 67
 - spare part number 24, 31, 35, 68
- Display Hinge Kit, spare part number 24, 31, 35
- display inverter
 - illustrated 24
 - spare part number 24, 31, 35
- Display Miscellaneous Kit, spare part number 33
- display panel
 - illustrated 24
 - product description 2
 - removal 67
 - spare part number 24, 31, 33, 34, 67
- Display Rubber Kit, spare part number 25, 31, 35
- Display Screw Kit, spare part number 25, 31, 35
- display specifications 92
- displaying system information 88
- docking support, product description 4
- drive light, identifying 8
- drives, boot order 90
- drives, preventing damage 37
- DVD/CD-RW Combo Drive
 - precautions 37
 - removal 48
 - spare part number 22, 27, 32, 48
 - specifications 95
- DVD±RW and CD-RW Combo Drive
 - precautions 37
 - removal 48
- spare part number 22, 27, 32, 34, 48
- specifications 94

E

- electrostatic discharge 38
- eSATA/USB port, identifying 13
- esc key, identifying 11
- Ethernet, product description 3
- exiting the Setup Utility 88
- ExpressCard slot bezel 26
- ExpressCard slot, identifying 13
- external media cards, product description 3
- external monitor port
 - identifying 13
 - pin assignments 119

F

- f11 116, 117
- fan
 - removal 84
 - spare part number 21, 33, 84
- fan always on 90
- feet
 - locations 43
 - spare part number 43
- fingerprint reader 86
- fingerprint reader board
 - removal 61
 - spare part number 33, 61
- fingerprint reader, identifying 10
- fn key, identifying 11
- front components 6
- full system recovery 113
- function keys, identifying 11

G

- graphics, product description 1
- grounding equipment and methods 40

H

- hard drive
 - precautions 37
 - product description 2
 - removal 51
 - spare part numbers 23, 27, 32, 34, 51
 - specifications 93
- hard drive bay cover
 - illustrated 26
 - removing 51
 - spare part number 52
- hard drive bay, identifying 14
- Hard Drive Kit, spare part number 23, 27, 32, 51
- hard drive self test 90
- HDMI port, identifying 13
- headphone (audio-out) jacks 12
- headphone jack, pin assignments 118
- heat sink
 - removal 80
 - spare part number 20, 32, 35, 80

I

- I/O address specifications 98
- infrared lens, identifying 12
- integrated webcam light, identifying 15
- internal microphones, identifying 15
- interrupt specifications 97
- inverter
 - removal 66
 - spare part number 24, 31, 35, 67

J

- jacks
 - audio-in (microphone) 12
 - audio-out (headphone) 12
 - RJ-11 (modem) 12
 - RJ-45 (network) 12

K

- keyboard
 - product description 4
 - removal 54
 - spare part numbers 19, 32, 34, 54
- keyboard backlight LED 34
- keypad keys, identifying 11
- keys
 - esc 11
 - fn 11
 - function 11
 - keypad 11

- Windows applications 11
- Windows logo 11

L

- LAN Power Saving 89
- language support 89
- latch, battery release 14
- latches, optical drive release 14
- lights
 - battery 8
 - caps lock 7
 - drive 8
 - mute 7
 - num lock 7
 - optical drive 12
 - power 7, 12
 - TouchPad 6
 - volume down 7
 - volume mute 7
 - volume up 7
 - webcam 15
 - wireless 7

M

- Main menu 89
- mass storage devices, spare part numbers 27
- media activity buttons, identifying 10
- media button, identifying 9
- memory map specifications 96
- memory module
 - product description 2
 - removal 49
 - spare part numbers 23, 30, 31, 34, 49
- memory module compartment cover
 - illustrated 26
 - removal 49
 - spare part number 49
- memory module compartment, identifying 14
- memory test 90
- microphone
 - illustrated 24
 - product description 3
- microphone (audio-in) jack 12
- microphone jack
 - pin assignments 118

- model name 1
- modem jack, pin assignments 120
- modem module
 - removal 79
 - spare part numbers 20, 31, 32, 79
- modem, product description 3
- monitor port, external 13
- monitor port, pin assignments 119
- mute button, identifying 9
- mute light, identifying 7

N

- navigating in the Setup Utility 87
- network jack, pin assignments 120
- next/fast forward button, identifying 10
- num lock light, identifying 7

O

- operating system, product description 4
- optical drive
 - precautions 37
 - product description 3
 - removal 48
 - spare part numbers 22, 27, 48
 - specifications 94, 96
- Optical Drive Kit, spare part number 22, 28, 32
- optical drive light, identifying 12
- optical drive release latch, identifying 14
- optical drive, identifying 12

P

- packing guidelines 39
- password clearing 41
- plastic parts 36
- Plastics Kit
 - contents 26
 - spare part number 20, 26, 32, 35
- play/pause button, identifying 10
- pointing device, product description 4

- ports
 - eSATA/USB 13
 - external monitor 13
 - HDMI 13
 - product description 3
 - USB 12, 13
- power button, identifying 9
- power connector, identifying 12
- power cord
 - set requirements 122
 - spare part numbers 28, 30, 33
- power lights, identifying 7
- power requirements, product description 4
- power-on password 89
- previous/rewind button, identifying 10
- processor
 - product description 1
 - removal 82
 - spare part numbers 21, 31, 33, 35, 82
- Processor C4 State 89
- product description
 - audio 3
 - chipset 1
 - display panel 2
 - docking support 4
 - Ethernet 3
 - external media cards 3
 - graphics 1
 - hard drives 2
 - keyboard 4
 - memory module 2
 - microphone 3
 - modem 3
 - operating system 4
 - optical drives 3
 - pointing devices 4
 - ports 3
 - power requirements 4
 - processors 1
 - product name 1
 - security 4
 - serviceability 4
 - webcam 3
 - wireless 3
- product name 1

R

- recovering a program or driver 113
- recovering from the dedicated recovery partition 116
- recovering from the recovery discs 116
- recovery discs 113
- Recovery Manager 113, 116
- recovery partition 113
- recovery, system 116
- remote control, spare part numbers 28, 31
- removal/replacement
 - preliminaries 36
 - procedures 42
- restore points 115
- restoring default settings 88
- RJ-11 (modem) jack, identifying 12
- RJ-11 jack, pin assignments 120
- RJ-45 (network) jack, identifying 12
- RJ-45 jack, pin assignments 120
- RTC battery
 - removal 77
 - spare part number 20, 32, 77
- Rubber Foot Kit, spare part number 21, 32, 35, 43

S

- Screw Kit
 - contents 100
 - spare part number 29, 32, 35
- screw listing 100
- scrolling regions, TouchPad 6
- secondary hard drive self test 90
- security cable slot, identifying 13
- Security menu 89
- security, product description 4
- selecting in the Setup Utility 87
- serial number 17, 42
- service considerations 36
- serviceability, product description 4
- Setup Utility
 - Diagnostics menu 90
 - Main menu 89

- overview 86
- Security menu 89
- slots
 - Digital Media 13
 - ExpressCard 13
 - memory module 14
 - security cable 13
- solid-state drive (SSD) 116
- speakers
 - removal 74
 - spare part number 21, 32, 74
- speakers, identifying 12
- specifications
 - computer 91
 - display 92
 - DVD/CD-RW Combo Drive 95
 - DVD±RW and CD-RW Combo Drive 94
 - hard drive 93
 - I/O addresses 98
 - interrupts 97
 - memory map 96
 - optical drive 94, 96
 - system DMA 96
- starting the Setup Utility 86
- static-shielding materials 40
- stop button, identifying 10
- supported discs 114
- switch cover
 - removal 57
 - spare part number 19, 32, 35, 57
- system board
 - removal 70
 - spare part number 20, 31, 33
 - spare part numbers 70
- system DMA 96
- system failure or instability 113
- system information 89
- system memory map 96
- system recovery 116
- system restore points 113, 115

T

- thermal paste, replacement 81
- tools required 36

- top cover
 - removal 58
 - spare part number 20, 32, 35, 58
- TouchPad
 - buttons 6
 - identifying 6
 - scrolling regions 6
- TouchPad light, identifying 6
- TouchPad on/off button 6
- transporting guidelines 39

U

- Universal Serial Bus (USB) port, pin assignments 121
- unknown password 41
- USB ports, identifying 12, 13
- using system restore 115
- using the Setup Utility 87

V

- vents, identifying 13, 14
- Virtualization Technology 89
- volume down light, identifying 7
- volume mute button, identifying 9
- volume mute light, identifying 7
- volume scroll zone, identifying 9
- volume up light, identifying 7

W

- webcam, identifying 15
- webcam, product description 3
- webcam/microphone module
 - removal 66
 - spare part number 24, 31, 35, 66
- webcam/microphone module cable
 - removal 69
 - spare part number 25, 31
- Windows applications key, identifying 11
- Windows logo key, identifying 11
- wireless antenna
 - illustrated 24
 - removal 68
 - spare part number 25, 31, 35
- wireless antennae 16
- wireless button, identifying 10
- wireless light, identifying 7

- wireless module compartment
 - cover
 - illustrated 26
 - removal 46
 - spare part number 46
 - wireless module compartment, identifying 14
- wireless, product description 3
- WLAN module
 - removal 45
 - spare part numbers 22, 30, 31, 45
- workstation guidelines 39

