

# HP KVM Server Console Switch User Guide



October 2003  
Part Number 339674-001

© 2003 Hewlett-Packard Development Company, L.P.

Microsoft®, Windows®, and Windows NT® are US registered trademarks of Microsoft Corporation.

Energy Star® is a US registered mark of the United States Environmental Protection Agency.

Hewlett-Packard Company shall not be liable for technical or editorial errors or omissions contained herein. The information in this document is provided “as is” without warranty of any kind and is subject to change without notice. The warranties for HP products are set forth in the express limited warranty statements accompanying such products. Nothing herein should be construed as constituting an additional warranty.

HP KVM Server Console Switch User Guide

October 2003

Part Number 339674-001

### **Audience Assumptions**

This guide is for the person who installs, administers, and troubleshoots servers. HP assumes you are qualified in the servicing of computer equipment and trained in recognizing hazards in products with hazardous energy levels.



## **Important Safety Information**

Before installing this product, read the *Important Safety Information* document provided.

# Contents

<b>Installing the HP KVM Server Console Switch</b>	<b>7</b>
Overview.....	7
Installation Checklist.....	7
Kit Contents.....	7
Required Items Not Included.....	8
Optional Items.....	8
Required Tools.....	8
Rack Mounting the HP KVM Server Console Switch.....	8
Performing a Side-Mount Type A Installation.....	9
Performing a Side-Mount Type B Installation.....	10
Performing a Standard-Mount Installation.....	12
Performing a Cantilever-Mount Type A Installation.....	13
Performing a Cantilever-Mount Type B Installation.....	15
Components.....	17
Configuring the KVM Server Console Switch System.....	17
Adding Server Names.....	19
<b>Installing the Interface Adapter</b>	<b>21</b>
Overview.....	21
Configuring the Interface Adapter.....	21
<b>Installing the Expansion Module</b>	<b>23</b>
Overview.....	23
Installation Checklist.....	23
Kit Contents.....	23
Installing the Expansion Module Hardware.....	23
Performing a Side-Mount Installation.....	24
Performing a Rail-Mount Installation.....	25
Performing a Velcro-Mount Installation.....	26
Configuring the Expansion Module.....	26
<b>Cascading Console Switches</b>	<b>27</b>
Compatible Console Switch Models.....	27
Compaq Server Console Switch.....	28
HP IP Console Switch.....	29
Cascading an HP KVM Server Console Switch with another HP KVM Server Console Switch.....	29
Example of an HP KVM Server Console Switch Cascade Configuration.....	32

Cascading a Compaq Server Console Switch with an HP KVM Server Console Switch.....	33
Example of a Compaq Server Console Switch Cascade Configuration.....	35
Cascading an HP KVM Server Console Switch with an HP IP Console Switch.....	36
Example of an HP IP Console Switch Cascade Configuration.....	39

**Local Port Operation 41**

---

Local Port Operation Overview .....	41
Accessing the Main Dialog Box .....	41
Viewing and Selecting Ports and Servers .....	42
Soft Switching.....	46
Configuring Servers for Soft Switching .....	46
Soft Switching to a Server .....	47
Soft Switching to a Previous Server .....	47
Using Basic OSD Navigation Keys .....	48
Configuring the Setup Dialog Box.....	49
Accessing the Setup Dialog Box .....	49
Managing Routine Tasks for Servers.....	50
Assigning Server Names.....	50
Accessing the Names Dialog Box .....	50
Assigning Device Types .....	51
Accessing the Devices Dialog Box.....	51
Modifying Device Types .....	52
Assigning Names to Servers.....	54
Changing the Display Behavior .....	55
Accessing the Menu Dialog Box .....	55
Selecting the Display Order of Servers.....	55
Setting a Screen Delay Time .....	56
Controlling the Status Flag .....	56
Accessing the Flag Dialog Box .....	57
Displaying the Status Flag .....	57
Broadcasting to Servers .....	58
Broadcasting Keystrokes .....	58
Broadcasting Mouse Movements.....	59
Accessing the Broadcast Dialog Box.....	59
Broadcasting Selected Servers.....	59
Activating the Broadcast Dialog Box .....	60
Setting Up a Scan Pattern.....	60
Accessing the Scan Dialog Box.....	60
Adding Servers to the Scan List .....	61
Removing Servers from the Scan List .....	62
Activating Scan Mode .....	62
Deactivating Scan Mode.....	62
Setting Local Console Switch Security.....	63
Accessing the Security Dialog Box .....	64

Changing the Password.....	64
Setting Password Protection .....	64
Logging On to the KVM Server Console Switch .....	65
Removing the Password Protection .....	65
Exiting Screen Saver Mode .....	66
Activating Screen Saver Mode without Password Protection.....	66
Deactivating the Screen Saver .....	66
Changing the Switch Mode.....	67
Accessing the Switch Dialog Box .....	67
Managing Server Tasks Using the OSD .....	68
Accessing the Commands Dialog Box .....	68
Running System Diagnostics .....	69
Activating Run Diagnostics .....	71
Displaying Version Information .....	72
Accessing the Version Dialog Box.....	73

**Updating the Firmware** **75**

---

Updating the Console Switch Firmware .....	75
Updating the Interface Adapter Firmware Simultaneously.....	76
Updating the Interface Adapter Firmware Individually .....	76

**Troubleshooting** **79**

---

Troubleshooting Table .....	80
Connection Length Table.....	81

**Technical Support** **83**

---

HP Contact Information .....	83
Before You Contact HP .....	83

**Regulatory Compliance Notices** **85**

---

Regulatory Compliance Identification Numbers.....	85
Federal Communications Commission Notice.....	86
FCC Rating Label.....	86
Class A Equipment .....	86
Class B Equipment .....	87
Declaration of Conformity for Products Marked with the FCC Logo, United States Only .....	87
Modifications .....	88
Cables.....	88
Canadian Notice (Avis Canadien).....	88
European Union Notice.....	89
Japanese Notice.....	89
BSMI Notice .....	90
Korean Notices.....	90

<b>Acronyms and Abbreviations</b>	<b>91</b>
-----------------------------------	-----------

---

<b>Index</b>	<b>93</b>
--------------	-----------

---

---

# Installing the HP KVM Server Console Switch

## In This Section

Overview .....	7
Installation Checklist .....	7
Rack Mounting the HP KVM Server Console Switch .....	8
Components .....	17
Configuring the KVM Server Console Switch System .....	17
Adding Server Names.....	19

## Overview

The HP KVM Server Console Switch ships with rack mounting brackets for easy integration into your rack. Before installing the HP KVM Server Console Switch and other components in the rack cabinet (if not already installed), stabilize the rack in a permanent location. Begin installing your equipment at the bottom of the rack cabinet, then work to the top. Avoid uneven loading or overloading of the rack cabinets.

## Installation Checklist

Before installation, refer to the following lists to be sure that all of the listed components were received.

## Kit Contents

- KVM Server Console Switch
- Power cords
- Rack mounting kit
- Serial download cable
- Documentation kit

- Firmware CD kit

This kit might contain extra hardware for your convenience.

## Required Items Not Included

- PS/2 Interface Adapter or USB Interface Adapter
- UTP CAT5 cable (CAT6 and CAT7 may be also used)

## Optional Items

Expansion Module ("Installing the Expansion Module" on page 23)

## Required Tools

- Phillips screwdriver
- T-25 Torx driver

## Rack Mounting the HP KVM Server Console Switch

**NOTE:** Before installing the HP KVM Server Console Switch into the rack, connect the HP KVM Server Console Switch to a power source, using the power cords provided, and power on the unit. An activity indicator light ("Components" on page 17) is displayed after a few seconds. If the activity indicator light does not display, be sure that the power is on, the power cord is connected, and the power source is valid.

Several rack mounting configurations include:

- Side-mount
  - Type A—Square- and round-hole rails
  - Type B—Square-hole rails

**NOTE:** The HP KVM Server Console Switch cannot be side-mounted into a rack with round-hole rails.

- Standard-mount



- Cantilever-mount
  - Type A—Round-hole rails
  - Type B—Square-hole rails

## Performing a Side-Mount Type A Installation

1. Remove the four screws, two on each side, from the console switch.
2. Attach the side-mounting brackets to the console switch using the four screws you removed.

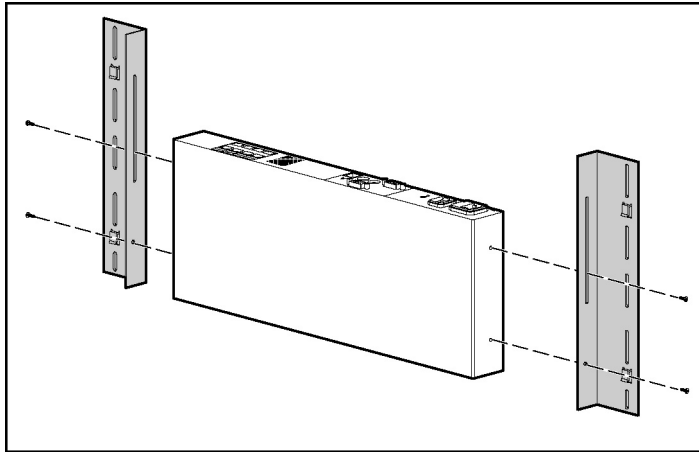

3. Slide the side-mounting bracket tabs into the U locations on each side of the rack.

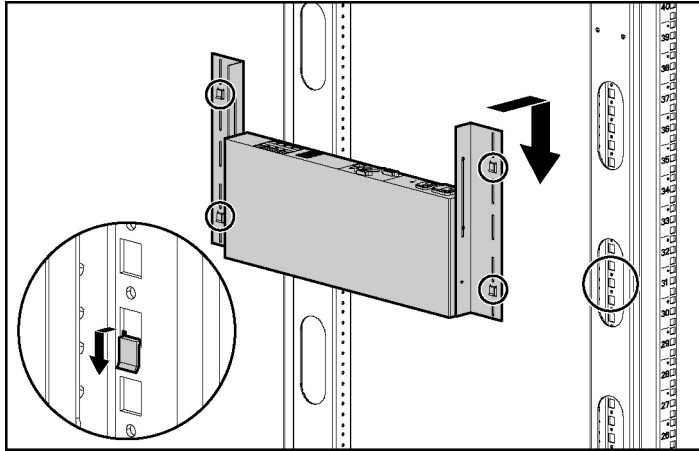

4. Secure the console switch to the rails using four self-tapping screws, two on each side.

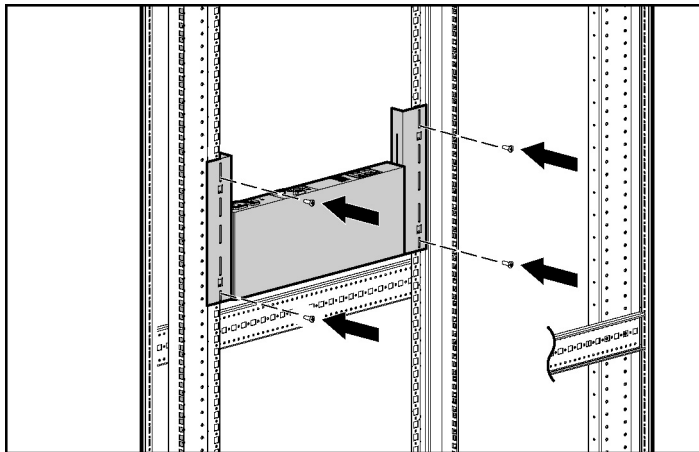

## Performing a Side-Mount Type B Installation

1. Remove the four screws, two on each side, from the console switch.

2. Attach the side-mounting brackets to the console switch using the four screws you removed.

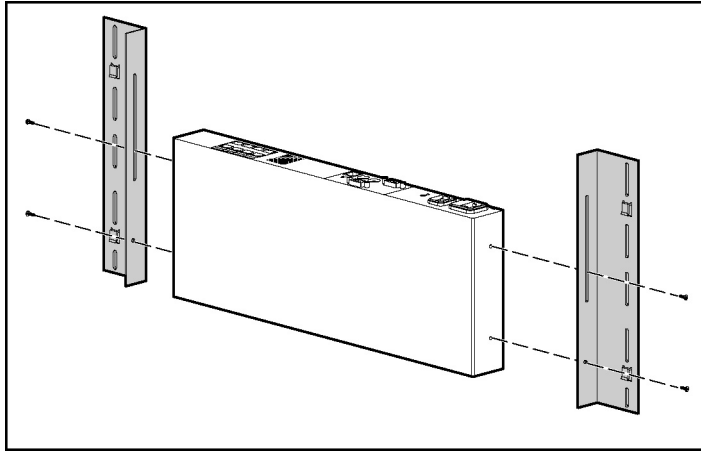

3. Slide the side-mounting bracket tabs into the U locations on each side of the rack.

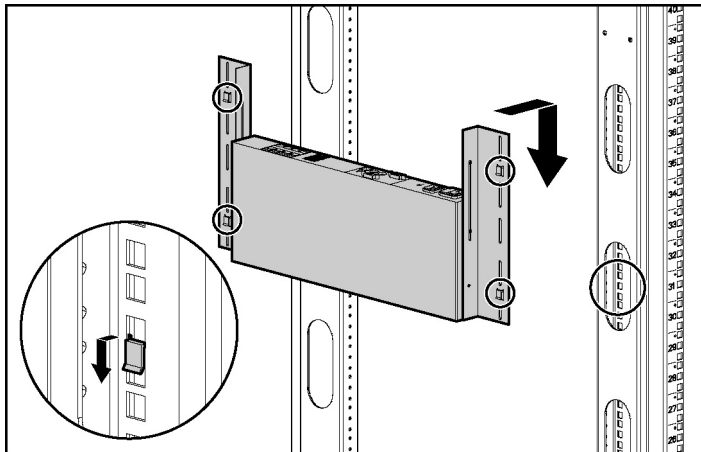

4. Install four cage nuts into the side-mounting bracket U locations.

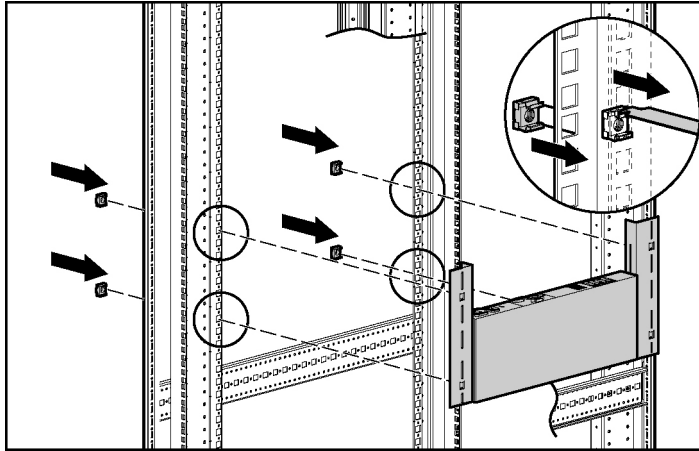

5. Secure the console switch to the rails, using four M-6 screws, two on each side.

## Performing a Standard-Mount Installation

1. Remove the four screws, two on each side, from the console switch.
2. Attach the 1U brackets to the console switch using the four screws you removed.

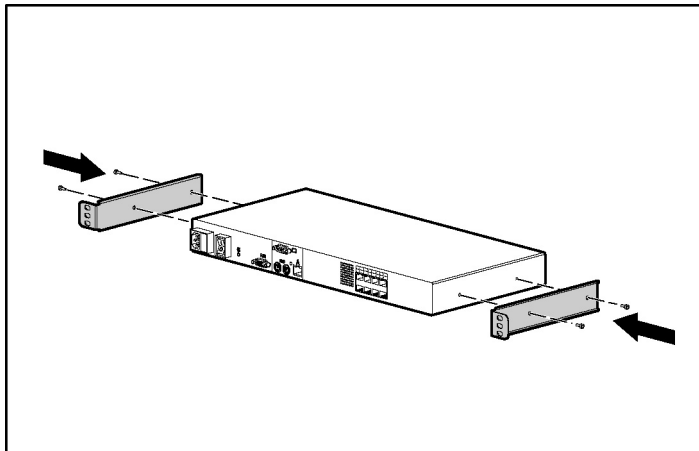

3. Install a cage nut behind each rear rail if they have not already been installed.
4. Slide the console switch into the rear of the 1U product.

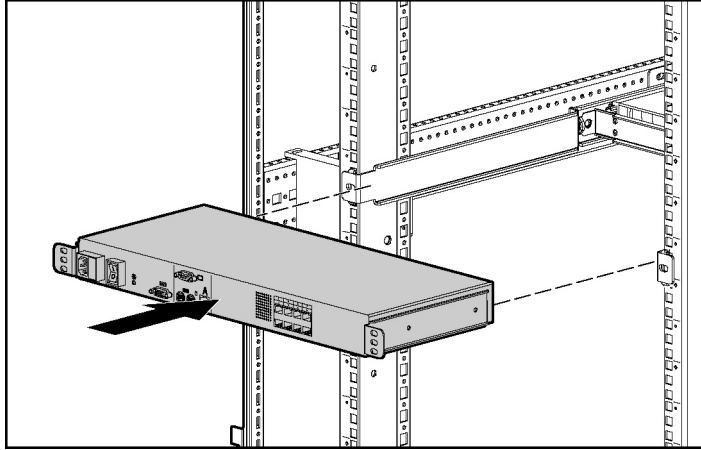

5. Secure the console switch to the rails using two M-6 screws, one on each side.

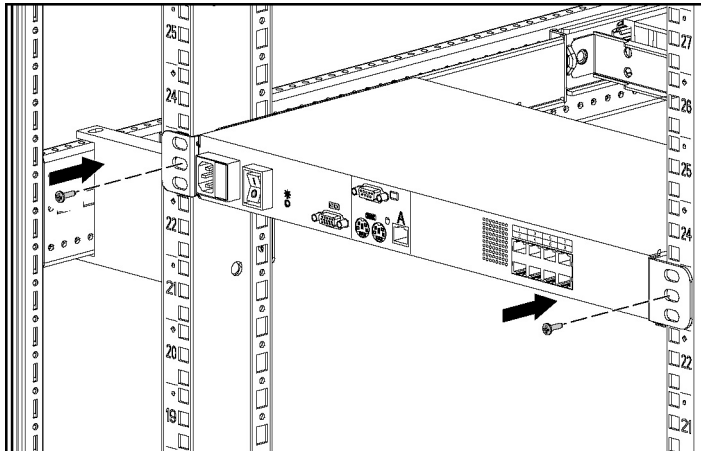

## Performing a Cantilever-Mount Type A Installation

1. Remove the four screws, two on each side, from the console switch.

2. Attach the 1U brackets to the console switch using the four screws you removed.

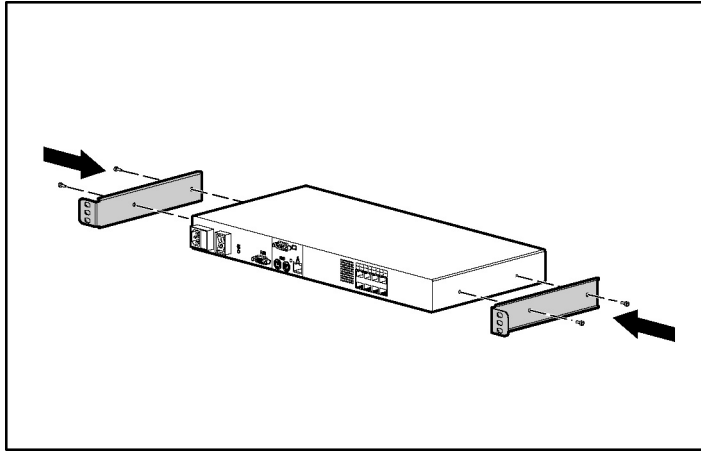

3. Install up to six clip nuts.

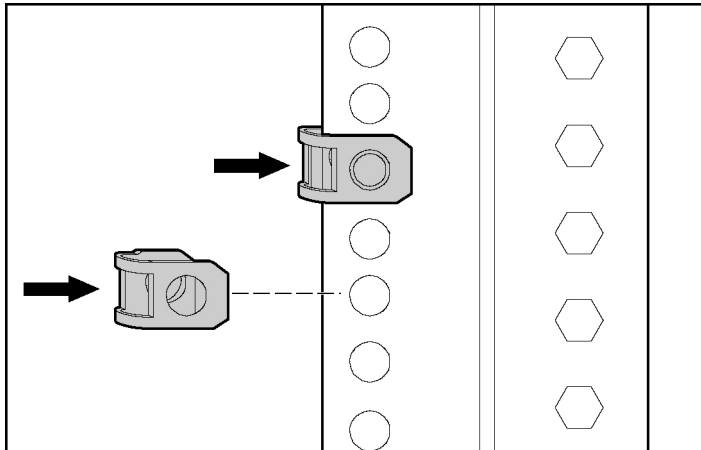

4. Secure the console switch to the rails, using the appropriate number of T-25 Torx screws.

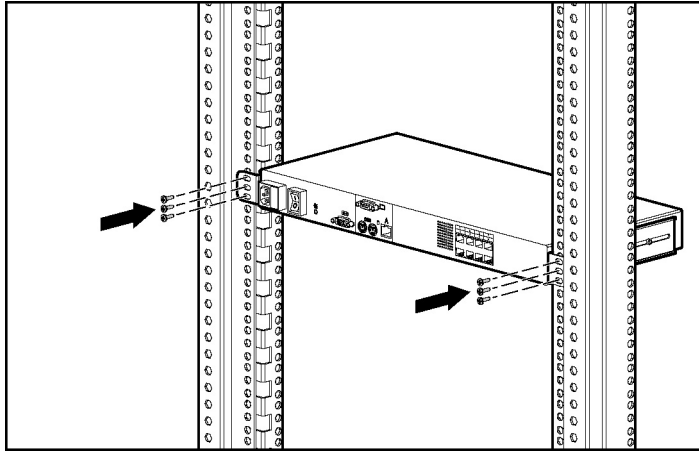

## Performing a Cantilever-Mount Type B Installation

1. Remove the four screws, two on each side, from the console switch.
2. Attach the 1U brackets to the console switch using the four screws you removed.

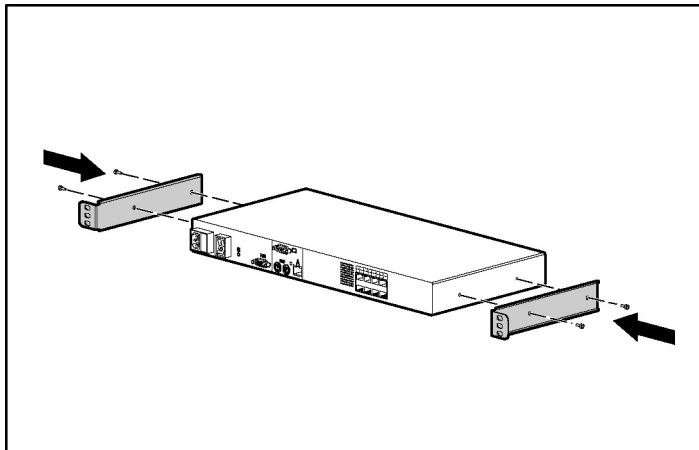

3. Install up to six cage nuts.

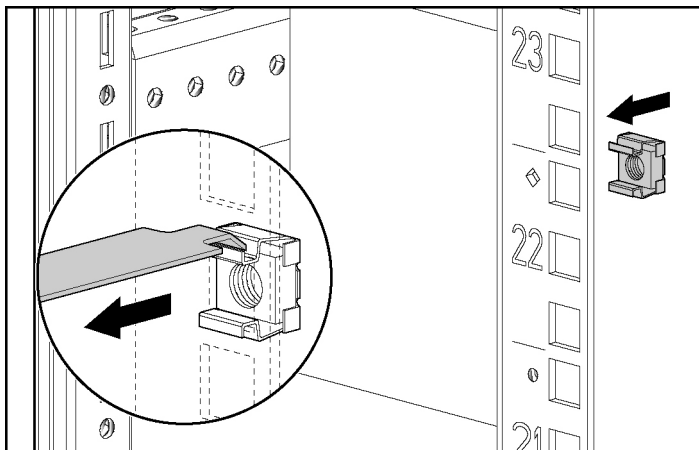

4. Secure the console switch to the rails using the appropriate number of M-6 screws.

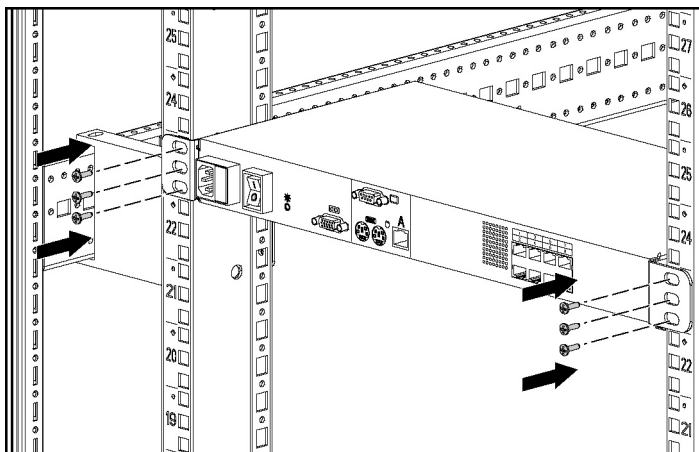



## Components

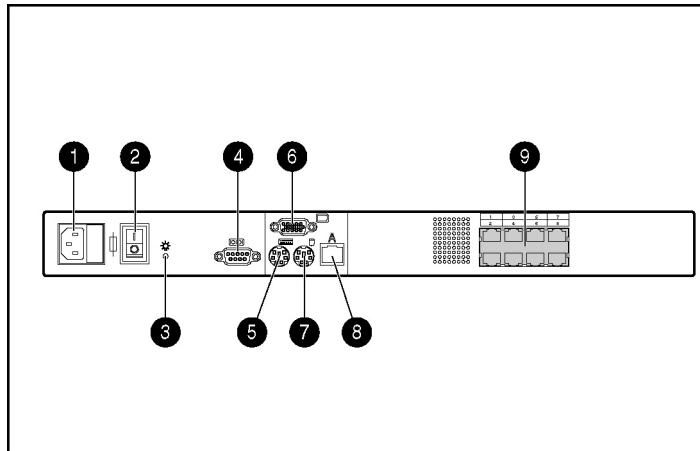

Item	Description
1	Power connector
2	Power switch
3	Activity indicator light
4	Serial download connector
5	Keyboard connector
6	Monitor connector
7	Mouse connector
8	RJ-45 Interface port (designated by the letter A)
9	Server connection ports

## Configuring the KVM Server Console Switch System

1. Connect the Expansion Module ("Installing the Expansion Module" on page 23).
2. Connect the Interface Adapter ("Installing the Interface Adapter" on page 21).

3. Power on the HP KVM Server Console Switch. The activity indicator light ("Components" on page 17) powers on.
4. Power on the monitor.
5. Power up the server.

The following figure shows one possible configuration for your HP KVM Server Console Switch system.

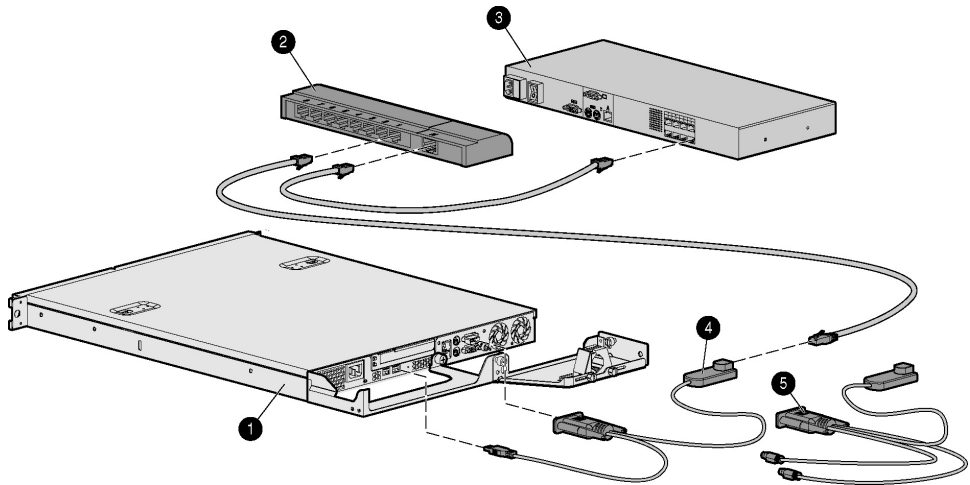

Item	Description
1	Server
2	Expansion Module
3	HP KVM Server Console Switch
4	USB Interface Adapter
5	PS/2 Interface Adapter

## Adding Server Names

You can configure the HP KVM Server Console Switch system through the OSD. When tiered with the IP Console Switch, HP recommends adding server names to the OSD at the local analog station before adding or discovering console switches through the IP Console Viewer.

To add server names, refer to the Assigning Server Names (on page 50) section.



---

# Installing the Interface Adapter

## In This Section

Overview .....	21
Configuring the Interface Adapter.....	21

## Overview

An Interface Adapter is required for the HP KVM Server Console Switch system to function properly. However, it is not included in the HP KVM Server Console Switch kit. An Interface Adapter connects UTP CAT5 cables to PS/2 or USB connections, establishing a KVM session to a server.

**NOTE:** UTP CAT5 cables are used throughout the examples in this guide. However, UTP CAT6 and UTP CAT7 cables may also be used.

## Configuring the Interface Adapter

1. Connect a UTP CAT5 cable to the server connection port ("Components" on page 17) on the HP KVM Server Console Switch.
2. Connect the other end of that same UTP CAT5 cable to the RJ-45 port on the Interface Adapter.
3. Connect the Interface Adapter to the appropriate ports on the server.
4. Repeat the preceding steps to connect any other servers to this system.

The following figure shows one possible configuration for your HP KVM Server Console Switch system with an Interface Adapter.

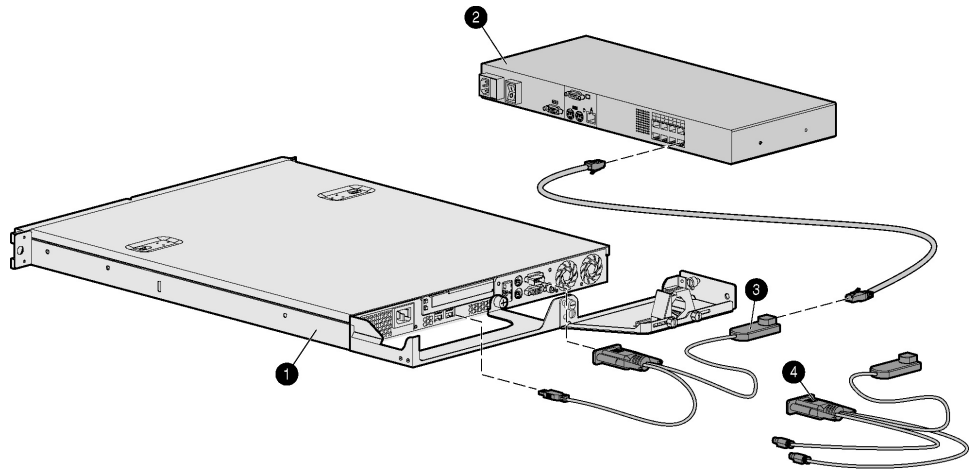

Item	Description
1	Server
2	HP KVM Server Console Switch
3	USB Interface Adapter
4	PS/2 Interface Adapter

---

# Installing the Expansion Module

## In This Section

Overview .....	23
Installation Checklist .....	23
Installing the Expansion Module Hardware .....	23
Configuring the Expansion Module .....	26

## Overview

An optional Expansion Module can be added to the HP KVM Server Console Switch system, increasing the total number of accessible servers. The Expansion Module ships with rack-mounting hardware for easy integration into your rack.

## Installation Checklist

Before installation, refer to the following lists to be sure that all of the listed components were received.

## Kit Contents

- Expansion Module
- Screws
- Velcro

This kit might contain extra hardware for your convenience.

## Installing the Expansion Module Hardware

Several rack mounting configurations include:

- Side-mount

- Rail-mount
- Velcro-mount

## Performing a Side-Mount Installation

1. Slide the tabs on the side-mounting brackets into the rack frame.

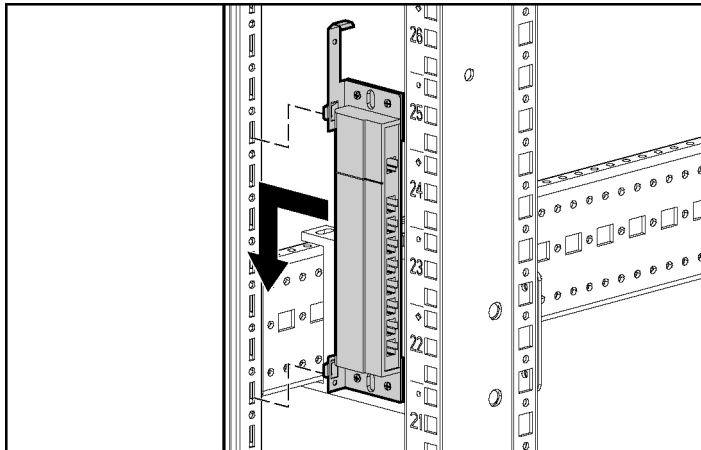

2. Secure the Expansion Module to the rack frame, using one self-tapping screw for the bottom side-mounting bracket.

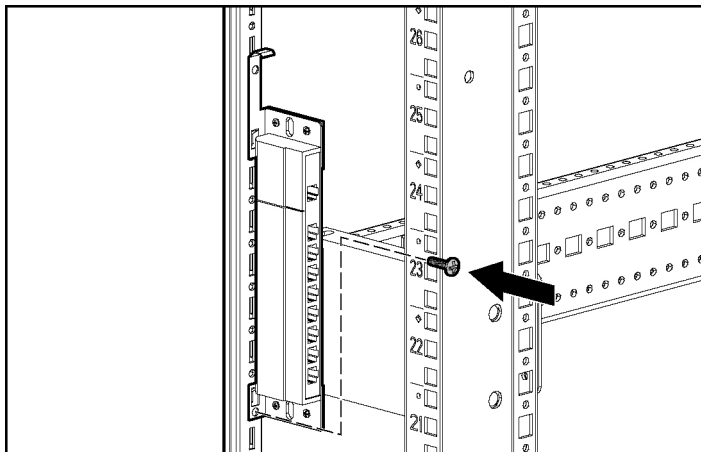



## Performing a Rail-Mount Installation

1. Remove the screws securing the side-mounting brackets to the Expansion Module.

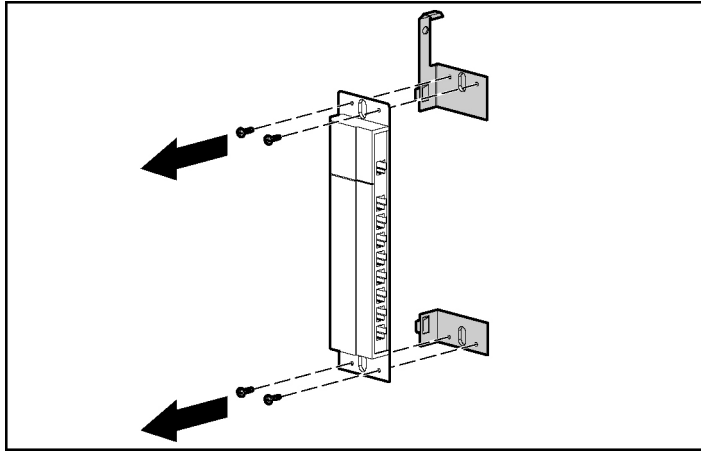

2. Insert two cage nuts into the rack frame where the side-mounting bracket holes are located and secure the Expansion Module to the rack frame, using two M-6 screws.

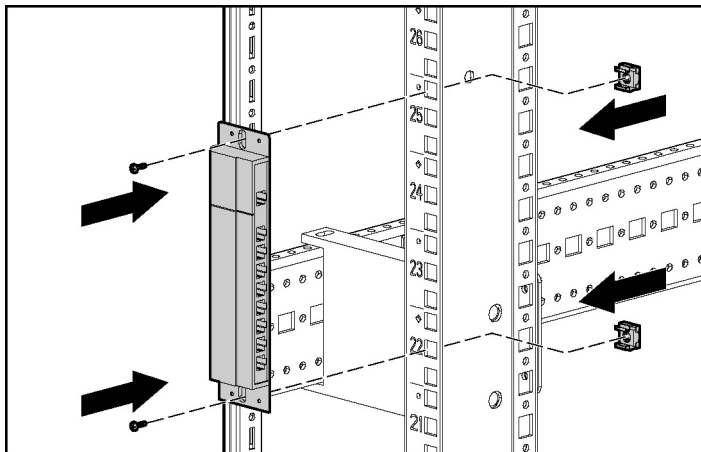

## Performing a Velcro-Mount Installation

1. Determine the location for the Expansion Module.
2. Remove the protective strip from one side of the Velcro and attach that side to the Expansion Module.
3. Remove the protective strip from the other side of the Velcro and attach the Expansion Module to the rack frame.

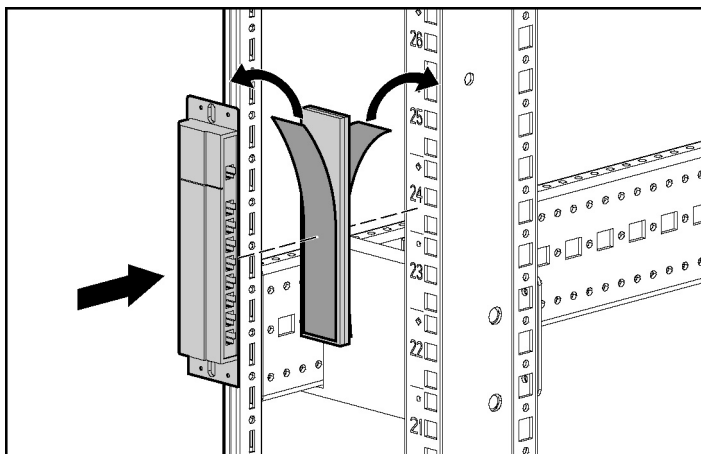

## Configuring the Expansion Module

1. Mount the Expansion Module into the rack.
2. Locate up to nine UTP CAT5 cables.
3. Connect a UTP CAT5 cable to the server connection port ("Components" on page 17) on the HP KVM Server Console Switch.
4. Connect the other end of that same UTP CAT5 cable to the IN port on the Expansion Module.
5. Connect one end of another UTP CAT5 cable to the OUT port on the Expansion Module.
6. Connect the other end of the second UTP CAT5 cable to the Interface Adapter ("Installing the Interface Adapter" on page 21).
7. Repeat steps 5 and 6 to connect any other servers to this system.

# Cascading Console Switches

## In This Section

Compatible Console Switch Models .....	27
Cascading an HP KVM Server Console Switch with another HP KVM Server Console Switch .....	29
Cascading a Compaq Server Console Switch with an HP KVM Server Console Switch.....	33
Cascading an HP KVM Server Console Switch with an HP IP Console Switch .....	36

## Compatible Console Switch Models

Review the following information before cascading console switches with this product.

This product supports only one level of cascading. An Expansion Module is considered a level of cascading and therefore cannot be used in combination with cascaded console switches.

To ensure optimum equipment performance while cascading console switches, follow the proper powering-on sequence—power on the console switches, monitor, and then servers.



**CAUTION:** Do not use Interface Adapters to cascade HP KVM Server Console Switches with HP KVM Server Console Switches. If Interface Adapters are used to cascade these products, undesirable operations might occur.

**NOTE:** The HP KVM Server Console Switch does not support Compaq KVM PCI Cards or HP legacy console switches.

**NOTE:** To perform a firmware upgrade for a cascaded HP KVM Server Console Switch and all attached Interface Adapters, you must locally connect the keyboard, monitor, and mouse to the cascaded HP KVM Server Console Switch to access the local OSD.

## Compaq Server Console Switch



**CAUTION:** While cascading a 2 x 8 Compaq Server Console Switch, connect only one Interface Adapter at any given time. Undesirable operations might occur if multiple Interface Adapters are attached.



**CAUTION:** While cascading console switches, be sure that the Compaq Server Console Switch is cascaded below the HP KVM Server Console Switch. Undesirable operations might occur if these specific cascading sequences are not followed.

The following Compaq Server Console Switches can be integrated into the HP KVM Server Console Switch system. Compatible Compaq Server Console Switch models include:

- 1 x 4 [PN: 400336 (-001)(-291)(B-31)]
- 1 x 8 [PN: 400337 (-001)(-291)(B-31)]
- 2 x 8 [PN: 400338 (-001)(-291)(B-31)]
- 2 x 8 48 VDC [PN: 400542 B-21]

All Compaq Server Console Switches must be upgraded with SoftPaq firmware, version 2.1.0 or later, when cascaded with this product.

## HP IP Console Switch



**CAUTION:** Do not use Interface Adapters to cascade HP IP Console Switches with HP KVM Server Console Switches. If Interface Adapters are used to cascade these products, undesirable operations might occur.



**CAUTION:** While cascading console switches, be sure that the HP KVM Server Console Switch is cascaded below the HP IP Console Switch. Undesirable operations might occur if these specific cascading sequences are not followed.

The following HP IP Console Switches can be integrated into the HP KVM Server Console Switch system. Compatible HP IP Console Switch models include:

- 1 x 1 x 16 [PN: 262585 (B-21)]
- 3 x 1 x 16 [PN: 262586 (B-21)]

All HP IP Console Switches must be upgraded with SoftPaq firmware, version 2.1.1 or later, when cascaded with this product.

## Cascading an HP KVM Server Console Switch with another HP KVM Server Console Switch

**NOTE:** To perform a firmware upgrade for a cascaded HP KVM Server Console Switch and all attached Interface Adapters, you must locally connect the keyboard, monitor, and mouse to the cascaded HP KVM Server Console Switch to access the local OSD.

1. Mount the console switches in the rack.
2. Locate a UTP CAT5 cable and connect one end to the server connection port ("Components" on page 17) on the cascaded HP KVM Server Console Switch.
3. Connect the other end of that same UTP CAT5 cable to the RJ-45 port on the Interface Adapter.
4. Connect the Interface Adapter to the appropriate ports on the server.

5. Repeat steps 1 through 3 for any other servers to be added to this system.
6. Connect the local port KVM cable to the cascaded HP KVM Server Console Switch.
7. Power on the cascaded HP KVM Server Console Switch.
8. Power on the monitor.
9. Power up the server.
10. Update the cascaded HP KVM Server Console Switch firmware ("Updating the Firmware" on page 75).
11. Update all Interface Adapter firmware ("Updating the Firmware" on page 75).
12. Power off the cascaded HP KVM Server Console Switch.
13. Disconnect the local KVM cables from the cascaded HP KVM Server Console Switch.
14. Connect the local port KVM cable to the main HP KVM Server Console Switch.
15. Connect a UTP CAT5 cable to the server connection port ("Components" on page 17) on the main HP KVM Server Console Switch.
16. Connect the other end of that same UTP CAT5 cable to the RJ-45 interface port ("Components" on page 17) on the cascaded HP KVM Server Console Switch.
17. Repeat steps 15 and 16 for any other console switches to be added to this system.
18. Power on the console switches.
19. Power on the monitor.
20. Update the main HP KVM Server Console Switch firmware ("Updating the Firmware" on page 75).
21. Update all Interface Adapter firmware ("Updating the Firmware" on page 75).

The following figure shows an HP KVM Server Console Switch cascaded to another HP KVM Server Console Switch. The top console switch is the main console switch, while the bottom console switch is the cascaded console switch.



**CAUTION:** Do not use Interface Adapters to cascade HP KVM Server Console Switches with HP KVM Server Console Switches. If Interface Adapters are used to cascade these products, undesirable operations might occur.

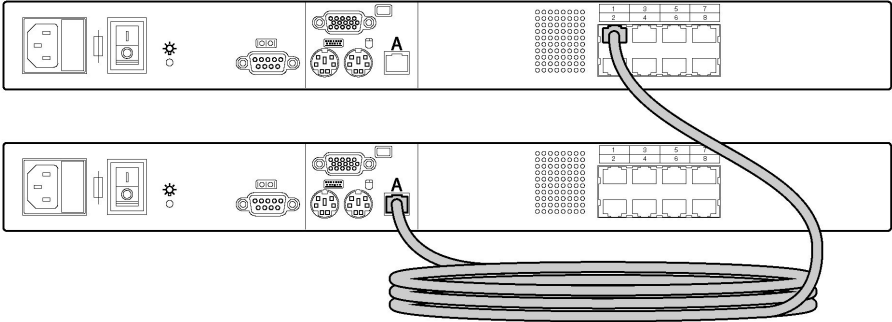

## Example of an HP KVM Server Console Switch Cascade Configuration

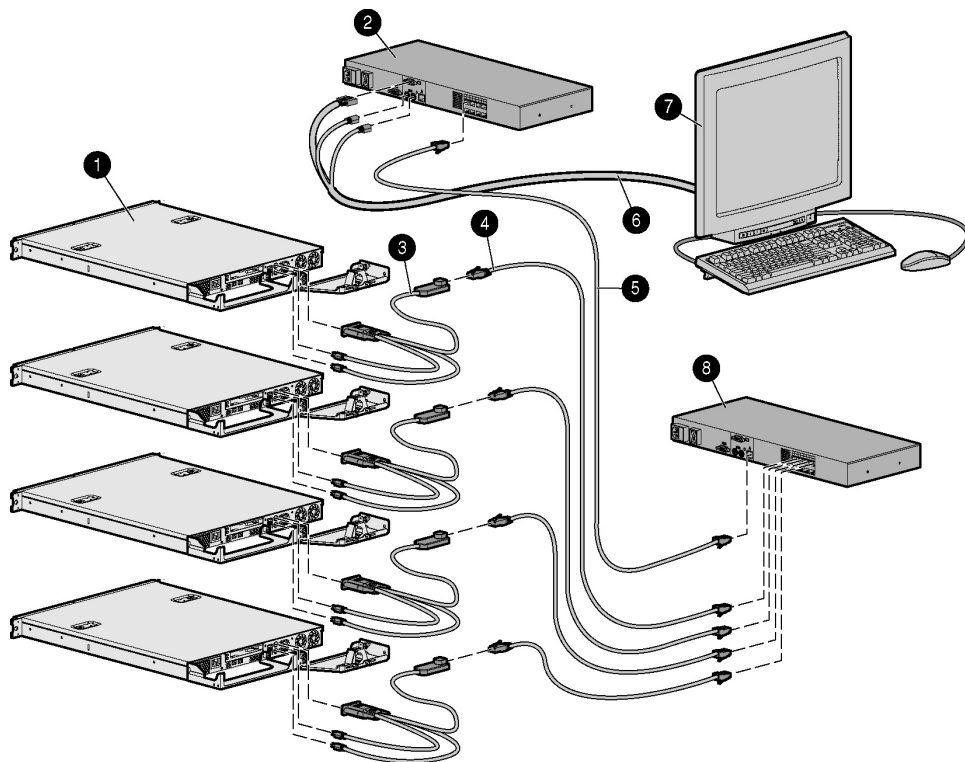



Item	Description
1	Server
2	Main HP KVM Server Console Switch
3	PS/2 Interface Adapter or USB Interface Adapter*
4	UTP CAT5 cable
5	UTP CAT5 cable
6	KVM cable
7	Local port
8	Cascaded HP KVM Server Console Switch
* not shown	

## Cascading a Compaq Server Console Switch with an HP KVM Server Console Switch

1. Mount the console switches in the rack.
2. Connect the local port KVM cable to the HP KVM Server Console Switch.
3. Connect a UTP CAT5 cable to the server connection port ("Components" on page 17) on the HP KVM Server Console Switch.
4. Connect the other end of that same UTP CAT5 cable to the RJ-45 port on the Interface Adapter.
5. Connect the Interface Adapter to the appropriate ports on the Compaq Server Console Switch.
6. Connect a KVM cable to the out port on the Compaq Server Console Switch.
7. Connect the other end of that same KVM cable to the appropriate port on the server.
8. Repeat steps 3 through 7 for any other console switches to be added to this system.
9. Power on the console switches.
10. Power on the monitor.



# Example of a Compaq Server Console Switch Cascade Configuration

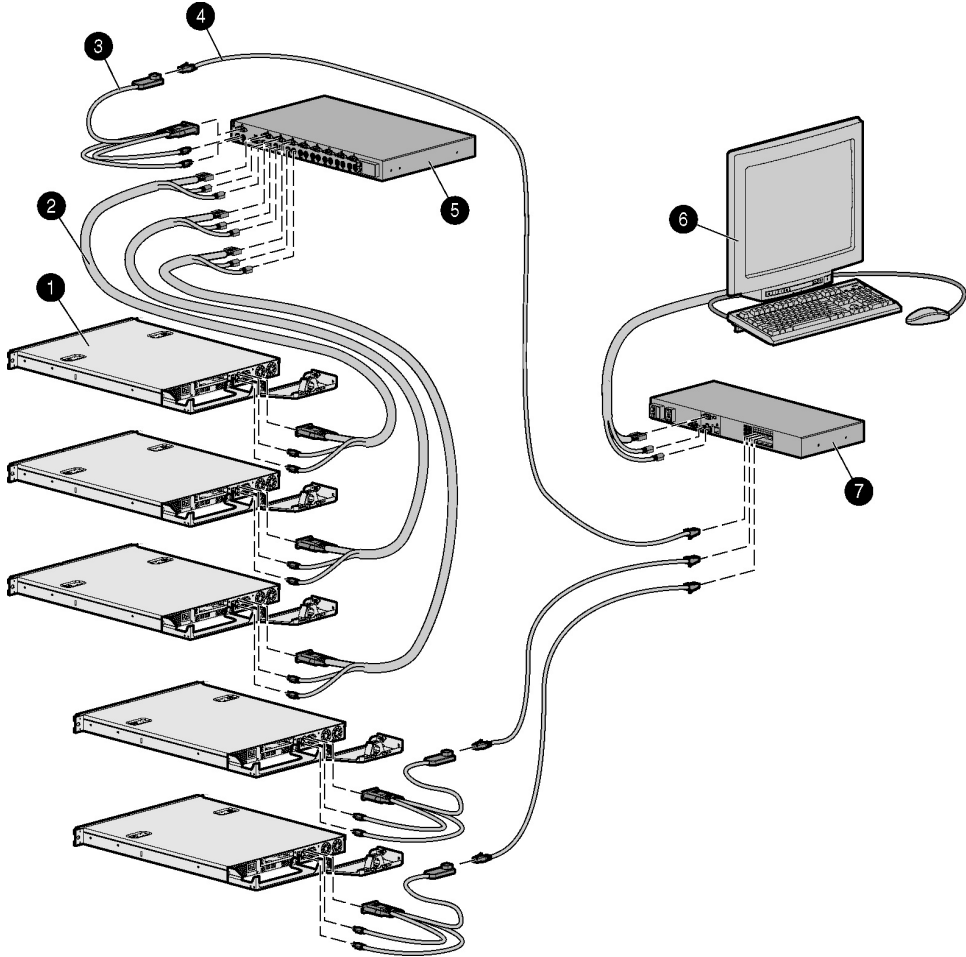

Item	Description
1	Server
2	KVM cable
3	PS/2 Interface Adapter
4	UTP CAT5 cable
5	Main Compaq Server Console Switch
6	Local port
7	Cascaded HP KVM Server Console Switch

## Cascading an HP KVM Server Console Switch with an HP IP Console Switch

**NOTE:** To perform a firmware upgrade for a cascaded HP KVM Server Console Switch and all attached Interface Adapters, you must locally connect the keyboard, monitor, and mouse to the cascaded HP KVM Server Console Switch to access the local OSD.

1. Mount the console switches in the rack.
2. Locate a UTP CAT5 cable and connect one end to the server connection port ("Components" on page 17) on the cascaded HP KVM Server Console Switch.
3. Connect the other end of that same UTP CAT5 cable to the RJ-45 port on the Interface Adapter.
4. Connect the Interface Adapter to the appropriate ports on the server.
5. Repeat steps 1 through 3 for any other servers to be added to this system.
6. Connect the local port KVM cable to the cascaded HP KVM Server Console Switch.
7. Power on the cascaded HP KVM Server Console Switch.
8. Power on the monitor.
9. Power down the server.

10. Update the cascaded HP KVM Server Console Switch firmware ("Updating the Firmware" on page 75).
11. Update all Interface Adapter firmware ("Updating the Firmware" on page 75).
12. Power off the cascaded HP KVM Server Console Switch.
13. Disconnect the local KVM cables from the cascaded HP KVM Server Console Switch.
14. Connect the local port KVM cable to main HP IP Console Switch.
15. Connect a UTP CAT5 cable to the server connection port ("Components" on page 17) on the main HP IP Console Switch.
16. Connect the other end of that same UTP CAT5 cable to the RJ-45 interface port ("Components" on page 17) on the cascaded HP KVM Server Console Switch.
17. Repeat steps 15 and 16 for any other console switches to be added to this system.
18. Power on the console switches.
19. Power on the monitor.
20. Update the main HP IP Console Switch firmware (refer to the HP IP Console Switch documentation).
21. Update all Interface Adapter firmware ("Updating the Firmware" on page 75).

The following figure shows an HP IP Console Switch cascaded to an HP KVM Server Console Switch. The top console switch is the main console switch, while the bottom console switch is the cascaded console switch.



**CAUTION:** Do not use Interface Adapters to cascade HP IP Console Switches with HP KVM Server Console Switches. If Interface Adapters are used to cascade these products, undesirable operations might occur.

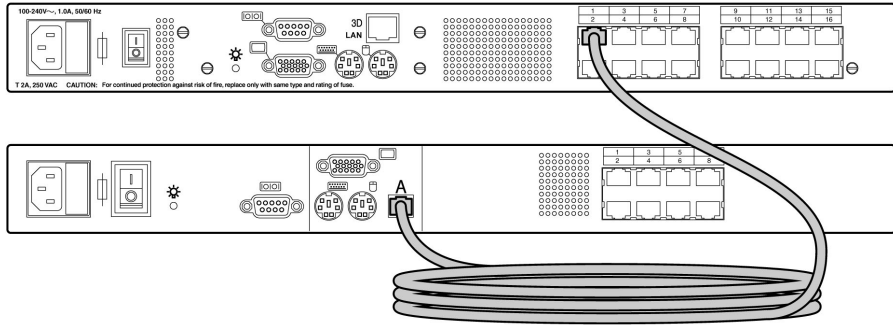

## Example of an HP IP Console Switch Cascade Configuration

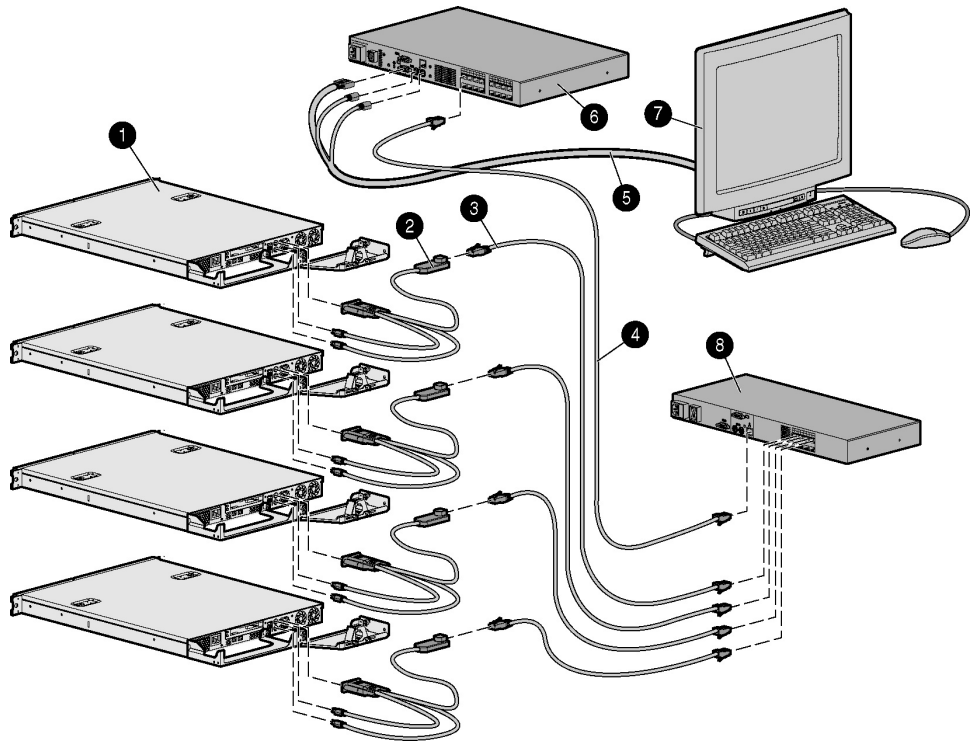

Item	Description
1	Server
2	PS/2 Interface Adapter or USB Interface Adapter*
3	UTP CAT5 cable
4	UTP CAT5 cable
5	KVM cable
6	Main HP IP Console Switch
7	Local port
8	Cascaded HP KVM Server Console Switch
* not shown	





# Local Port Operation

## In This Section

Local Port Operation Overview .....	41
Soft Switching .....	46
Using Basic OSD Navigation Keys .....	48
Configuring the Setup Dialog Box .....	49
Assigning Server Names .....	50
Assigning Device Types .....	51
Changing the Display Behavior .....	55
Controlling the Status Flag .....	56
Broadcasting to Servers .....	58
Setting Up a Scan Pattern .....	60
Setting Local Console Switch Security .....	63
Changing the Switch Mode .....	67
Managing Server Tasks Using the OSD .....	68
Running System Diagnostics .....	69
Displaying Version Information .....	72

## Local Port Operation Overview

The HP KVM Server Console Switch system has at least one local port (based on the specific model) on the rear panel ("Components" on page 17) that enables the user to connect a keyboard, monitor, and mouse to the HP KVM Server Console Switch for direct access.

Use the **Main dialog box** ("Accessing the Main Dialog Box" on page 41) to view, configure, and control servers in the HP KVM Server Console Switch system.

## Accessing the Main Dialog Box

Press the **Print Scrn** key. The **Main** dialog box is displayed.

**NOTE:** You can also press the **Ctrl** key twice within one second to launch the OSD. You can use this key sequence in any place you see **Print Scrn.**

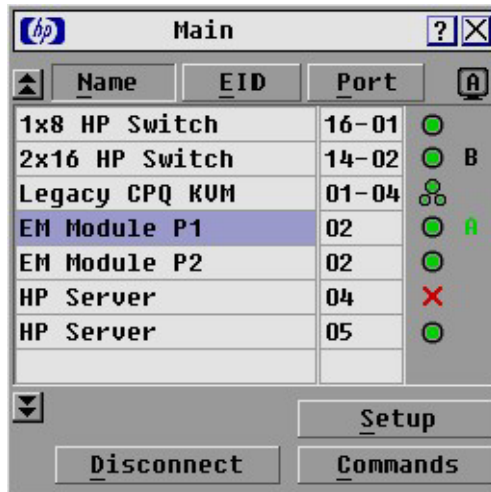

## Viewing and Selecting Ports and Servers







You can view servers by name, port, or by the unique EID embedded in each Interface Adapter.

### Viewing the Port Column

When the Main dialog box ("Accessing the Main Dialog Box" on page 41) is first launched, an OSD-generated port list is displayed by default.









The **Port** column indicates the port to which a server is connected. For example, in the following screen shot, the first number represents the port number of the first console switch and the second number represents the port number of the cascaded console switch port to which the server is connected.

<b>Port</b>
<b>16-01</b>
<b>14-02</b>
<b>01-04</b>
<b>02</b>
<b>02</b>
<b>04</b>
<b>05</b>

Port number of the first console switch	Port number of the cascaded console switch	Server Status Icon displayed ("Viewing the Server Status Column" on page 44)	Description
16	01		The server is connected to port 01 of the 1 x 8 HP KVM Server Console Switch, and that HP KVM Server Console Switch is cascaded from port 16 of the first HP KVM Server Console Switch.
14	02		The server is connected to port 02 of the 2 x 16 HP KVM Server Console Switch, and that HP KVM Server Console Switch is cascaded from port 14 of the first HP KVM Server Console Switch.
01	04		The server is connected to port 04 of the Compaq Server Console Switch, and that Compaq Server Console Switch is cascaded from port 01 of the first HP KVM Server Console Switch.
02			The servers are connected to an Expansion Module so they are using the same port. You can tell that the Expansion Modules are not cascaded because they do not have the second port numbers.
02			The servers are connected to an Expansion Module so they are using the same port. You can tell that the Expansion Modules are not cascaded because they do not have the second port numbers.
04			The server is connected to the first console switch and the Interface Adapter is not connected or the server is powered off.
05			The server is connected to the first console switch and is active.

## Viewing the Server Status Column

The status of the servers in the HP KVM Server Console Switch system are indicated by the icons in the right column of the Main dialog box ("Accessing the Main Dialog Box" on page 41).

Item	Description
	The Interface Adapter is connected directly, cascaded through an HP KVM Server Console Switch or an Expansion Module, or powered on.
	The Interface Adapter is not connected or the server is powered off.
	The Interface Adapter is cascaded to a Compaq Server Console Switch and the server is not connected or is powered off.
	The Interface Adapter is cascaded to a Compaq Server Console Switch and the server is connected or is powered on.
	The Interface Adapter is being upgraded.
	A symbol that identifies which port the console switch is connected to.
	A symbol that identifies which port you are actively connected to and viewing.
	A symbol that identifies to which port you are connected but which port you are not active.

## Selecting Servers

From the Main dialog box ("Accessing the Main Dialog Box" on page 41), users can select specific servers. When a new server is selected, the console switch reconfigures the KVM to the setting for the selected server.

Double-click the server **Name**, **EID**, or **Port** number.

-or-

If the display order of the server list is by **Port** (the **Port** button is clicked), enter the port number and press the **Enter** key.

-or-

If the display order of the server list is by **Name** or **EID** number (the **Name** or **EID** button is clicked), enter the first few letters of the name of the server or the **EID** number to establish it as unique, and then press the **Enter** key.

**NOTE:** The EID is an electronic identification number, found on the Interface Adapter cable label, automatically assigned to the Interface Adapter.

### Selecting Previous Servers

Press the **Print Scrn** key, then press the **Backspace** key. This key combination toggles between the previous and current connection.

### Disconnecting from a Server

Press the **Print Scrn** key, then press the **Alt + 0** keys.

-or-

Click **Disconnect**.

This leaves no server selected and in a free state. The status flag ("Controlling the Status Flag" on page 56) on the OSD displays **Free**.

## Soft Switching

Soft switching is the ability to switch servers using a hotkey sequence. You can soft switch to a server by pressing the **Print Scrn** key and entering the first few characters of its name or number. If you have set a **Screen Delay Time** ("Setting a Screen Delay Time" on page 56) and you press the key sequences before that time has elapsed, the OSD does not display.

## Configuring Servers for Soft Switching

1. From the Main dialog box ("Accessing the Main Dialog Box" on page 41), click **Setup>Menu**. The **Menu** dialog box is displayed.
2. For **Screen Delay Time**, enter the number of seconds of delay desired before the **Main** dialog box displays after the **Print Scrn** key is pressed.

3. Click **OK** to save settings.

## Soft Switching to a Server

To select a server, press the **Print Scrn** key. If the display order of your server list is by **Port** (the **Port** button is clicked), enter the port number and press the **Enter** key.

-or-

If the display order of the server list is by **Name** or **EID** number (the **Name** or **EID** button is clicked), enter the first few letters of the name of the server or the **EID** number to establish it as unique, and then press the **Enter** key.

## Soft Switching to a Previous Server

Press the **Print Scrn** key, then press the **Backspace** key. This key combination toggles between the previous and current connection.

## Using Basic OSD Navigation Keys

Keystroke	Description
<b>Print Scrn</b>	Opens the OSD <b>Main</b> dialog box. Press the <b>Print Scrn</b> key twice to send the <b>Print Scrn</b> keystroke to the currently selected device.
<b>F1</b>	Opens the <b>Help</b> screen for the current dialog box.
<b>Esc</b>	Closes the current dialog box without saving changes and returns to the previous dialog box. In the <b>Main</b> dialog box, it closes the OSD and returns to the selected server. In a message box, it closes the pop-up box and returns to the current dialog box.
<b>Alt</b>	Opens dialog boxes, selects options, and executes actions, when used in combination with the other keys.
<b>Alt + X</b>	Closes the current dialog box and returns to the previous dialog box.
<b>Alt + 0</b>	Selects the <b>OK</b> button and returns to the previous dialog box.
<b>Enter</b>	Completes the console switch operation in the <b>Main</b> dialog box and exits the OSD.
<b>Single-click, Enter</b>	Selects the text, in a text box, for editing and enables the left and right arrow keys to move the cursor. Press the <b>Enter</b> key again to quit Edit mode.
<b>Print Scrn, Backspace</b>	Toggles back to the previous selection if no other keystrokes have been entered.
<b>Print Scrn, Alt + 0</b>	Disengages the user immediately from a server—no server is selected. Status <b>Flag</b> displays <b>Free</b> . (This only applies to the <b>0</b> on the keyboard, not the keypad.)
<b>Print Scrn, Pause</b>	Activates the Screen Saver mode immediately and prevents access to that particular console if it is password protected.
<b>Up or Down</b> arrows	Moves the cursor from line to line.
<b>Right or Left</b> arrows	Moves the cursor between columns. When editing a text box, these keys move the cursor within the column.
<b>Page Up or Page Down</b>	Pages up and down through <b>Name</b> and <b>Port</b> lists.
<b>Home or End</b>	Moves the cursor to the top or bottom of a list.
<b>Backspace</b>	Erases characters in a text box.
<b>Delete</b>	Deletes current selection in the <b>Scan</b> dialog box or characters in a text box.



Keystroke	Description
Shift, Delete	Deletes from current selection to all lines below it when editing a scan list.
Numbers	Adds numbers from the keyboard or keypad.
Caps Lock	Disables the user. (Use the <b>Shift</b> key to change case.)

## Configuring the Setup Dialog Box

You can configure the HP KVM Server Console Switch and manage routine tasks for your servers from the **Setup dialog box** ("Accessing the Setup Dialog Box" on page 49) within the OSD. Click **Names** when initially setting up your console switch to identify servers by unique names.

## Accessing the Setup Dialog Box

From the Main dialog box ("Accessing the Main Dialog Box" on page 41), click **Setup**. The **Setup** dialog box is displayed.



## Managing Routine Tasks for Servers

Button	Function
<b>Menu</b>	Changes the server listing between numerically by port or EID number and alphabetically by name.  Changes the <b>Delay Time</b> before the <b>Main</b> dialog box displays after pressing the <b>Print Scrn</b> key.
<b>Flag</b>	Changes the display, timing, color, and location of the status flag.
<b>Broadcast</b>	Controls multiple servers simultaneously through keyboard and mouse actions.
<b>Scan</b>	Sets up custom scan patterns for up to 16 servers.
<b>Security</b>	Sets password to restrict server access and enables screen saver. A valid password must be alphanumeric and contain a minimum of five characters and a maximum of 15 characters. Permitted characters are case-sensitive and can consist of A–Z, 0–9, spaces, and hyphens.  Enables the Screen Saver mode.
<b>Switch</b>	Changes the Switch mode to preemptive or cooperative.
<b>Devices</b>	Identifies device types attached to the HP KVM Server Console Switch, including servers and other console switches.
<b>Names</b>	Identifies servers by unique names.

## Assigning Server Names

Use the **Names dialog box** ("Accessing the Names Dialog Box" on page 50) to identify individual servers by name rather than by port number. The **Names** list is always sorted by port order, and the names are stored in the Interface Adapter ("Installing the Interface Adapter" on page 21). If you move the Interface Adapter or server to another switch port, the HP KVM Server Console Switch recognizes the names and configurations.

## Accessing the Names Dialog Box

From the Main dialog box ("Accessing the Main Dialog Box" on page 41), click **Setup>Names**. The **Names** dialog box is displayed.

**NOTE:** If the server list has changed since it was last displayed, the mouse cursor turns into an hourglass as the list automatically updates. No mouse or keyboard input is accepted until the list update is complete.

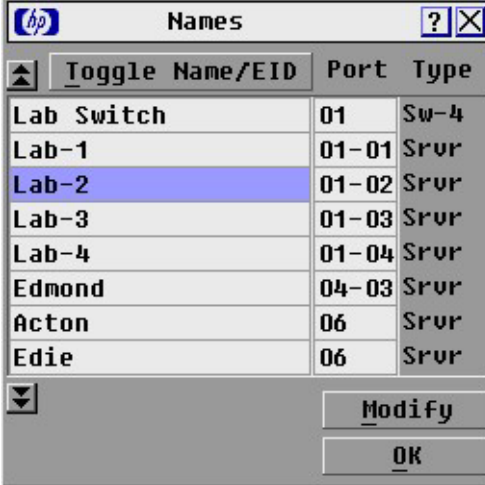

Toggle Name/EID	Port	Type
Lab Switch	01	Sw-4
Lab-1	01-01	Srvr
Lab-2	01-02	Srvr
Lab-3	01-03	Srvr
Lab-4	01-04	Srvr
Edmond	04-03	Srvr
Acton	06	Srvr
Edie	06	Srvr

## Assigning Device Types

While the HP KVM Server Console Switch automatically discovers cascaded Compaq Server Console Switches attached to your unit, you must specify the number of ports on the cascade Compaq Server Console Switch through the **Devices dialog box** ("Accessing the Devices Dialog Box" on page 51).

## Accessing the Devices Dialog Box

From the Main dialog box ("Accessing the Main Dialog Box" on page 41), click **Setup>Devices**. The **Devices** dialog box is displayed.

**NOTE:** The **Modify** button is only available if a configurable Compaq Server Console Switch is selected.

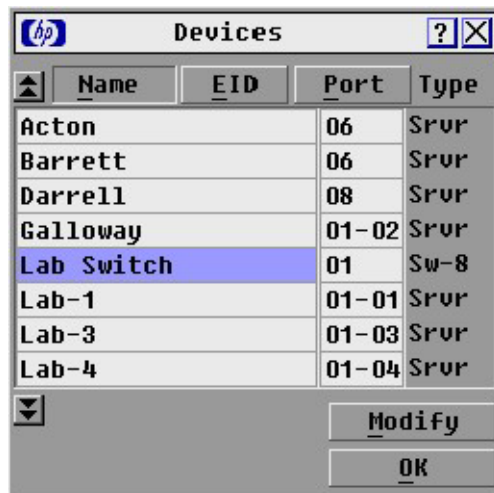

Name	EID	Port	Type
Acton		06	Srvr
Barrett		06	Srvr
Darrell		08	Srvr
Galloway		01-02	Srvr
Lab Switch		01	Sw-8
Lab-1		01-01	Srvr
Lab-3		01-03	Srvr
Lab-4		01-04	Srvr

When the HP KVM Server Console Switch discovers a cascaded HP KVM Server Console Switch, the port numbering changes automatically to accommodate each server under that HP KVM Server Console Switch. For example, if the HP KVM Server Console Switch is connected to port 02, the switch port is listed as 02, and each server under it is numbered sequentially 02-01, 02-02, and so on.

However, when a HP KVM Server Console Switch discovers a cascaded Compaq Server Console Switch, you must select the number of ports on the Compaq Server Console Switch through the **Device Modify** dialog box.

## Modifying Device Types

1. From the Devices dialog box ("Accessing the Devices Dialog Box" on page 51), select the Port number.

2. Click **Modify**. The **Device Modify** dialog box is displayed.

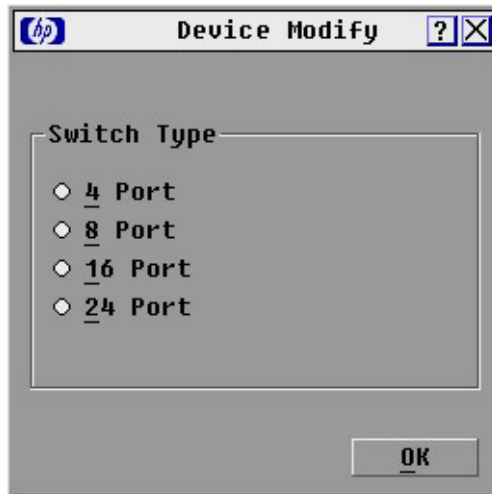

3. Select the number of ports supported by the cascaded Compaq Server Console Switch.
4. Click **OK**.
5. Repeat steps 2 through 4 for each port the user wants to assign a device type.
6. Click **OK** in the **Devices** dialog box to save settings.

-or-

Click **X** to exit, or press the **Esc** key to exit without saving settings.

**NOTE:** Changes made in the **Device Modify** dialog box are not saved until you click **OK** in the **Devices** dialog box.

## Assigning Names to Servers

1. From the Names dialog box ("Accessing the Names Dialog Box" on page 50), select the name or port number and click **Modify**. The **Name Modify** dialog box is displayed.

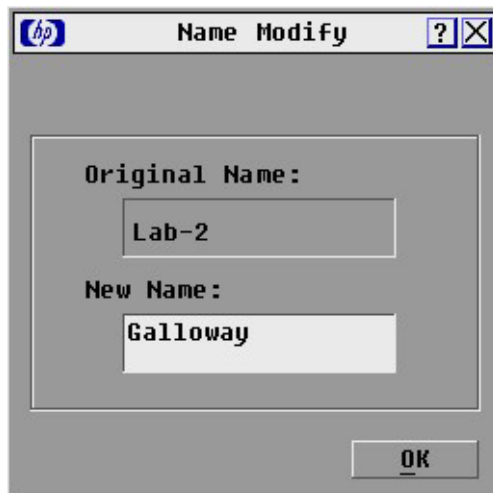

2. Enter a name in the **New Name** field. Names can be 1 to 15 characters in length. Permitted characters are case-sensitive and can consist of A–Z, 0–9, spaces, and hyphens.
3. Click **OK** to transfer the new name to the **Names** dialog box.
4. Repeat steps 3 through 5 for each server in the system.
5. Click **OK** to save settings.

-or-

Click **X** to exit, or press the **Esc** key to exit without saving settings.

**NOTE:** Changes made in the **Name Modify** dialog box are not saved until you click **OK** in the **Names** dialog box.

## Changing the Display Behavior

From the **Menu dialog box** ("Accessing the Menu Dialog Box" on page 55), the display order of servers, HP KVM Server Console Switch connection mode, and a time to delay display of the OSD after pressing the **Print Scrn** key can be changed. The display order setting alters how servers display in several screens, including the **Main**, **Devices**, and **Broadcast** dialog boxes.

### Accessing the Menu Dialog Box

From the Main dialog box ("Accessing the Main Dialog Box" on page 41), click **Setup>Menu**. The **Menu** dialog box is displayed.

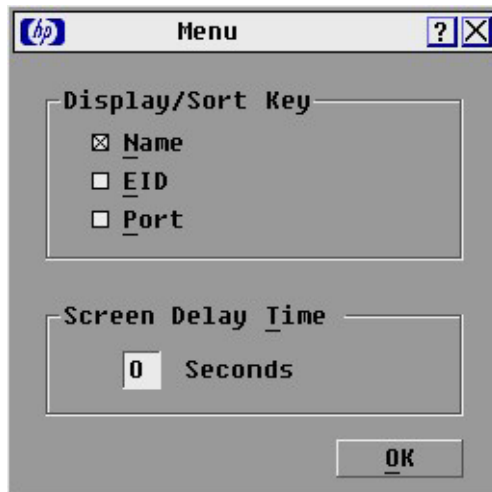

### Selecting the Display Order of Servers

1. From the Menu dialog box ("Accessing the Menu Dialog Box" on page 55), select **Name** to display servers alphabetically by name.

-or-

Select **EID** to display servers numerically by Interface Adapter ID number.

-or-

Select **Port** to display servers numerically by port number.

2. Click **OK** to save settings.

-or-

Click **X** to exit, or press the **Esc** key to exit without saving settings.

## Setting a Screen Delay Time

Setting a time to delay the display of the OSD enables you to complete a soft switch ("Soft Switching" on page 46) without displaying the OSD.



1. From the Main dialog box ("Accessing the Main Dialog Box" on page 41), enter the number of seconds (0–9) the OSD is delayed after pressing the **Print Scrn** key. Entering **0** instantly displays the OSD with no delay.
2. Click **OK** to save settings.

-or-

Click **X** to exit, or press the **Esc** key to exit without saving settings.

## Controlling the Status Flag

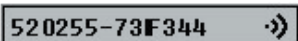
The status flag is displayed on the desktop and shows the Name or EID number of the selected server or the status of a particular port. Use the **Flag dialog box** ("Accessing the Flag Dialog Box" on page 57) to change the flag display by server name or EID number or to change the flag color, opacity, display time, and location on the desktop.

Flag	Description
	Flag type by name
	Flag type by EID number
	Flag indicating that the user has been disconnected from all systems

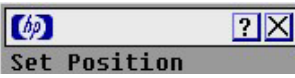

Flag	Description
	Flag indicating that the broadcast is activated
	Control used to set flag position

## Accessing the Flag Dialog Box

From the Main dialog box ("Accessing the Main Dialog Box" on page 41), click **Setup>Flag**. The **Flag** dialog box is displayed.

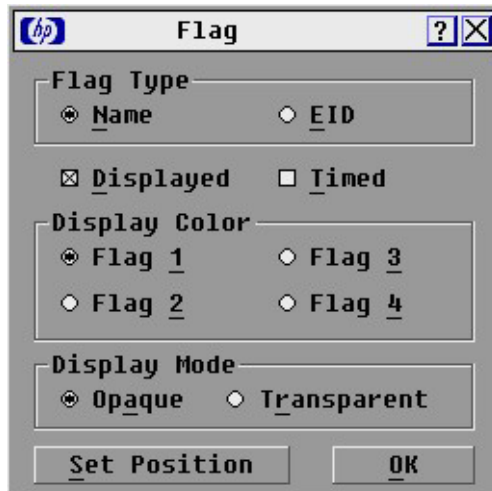

## Displaying the Status Flag

1. From the **Flags dialog box** ("Accessing the Flag Dialog Box" on page 57), select **Name** or **EID** to determine what information is displayed.
2. Select **Displayed** to show the flag constantly, or select **Timed** to display the flag for only five seconds after soft switching.
3. Select a flag color in **Display Color**.

4. In the **Display Mode**, select **Opaque** for a solid color flag or select **Transparent** to see the desktop through the flag.
5. Position the status flag on the desktop:
  - a. Click **Set Position** to gain access to the **Position Flag** screen.
  - b. Left-click and hold the title bar and drag to the desired location.
  - c. Right-click to return to the **Flag** dialog box.

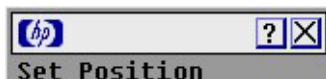

6. Click **OK** to save settings.

-or-

Click **X** to exit, or press the **Esc** key to exit without saving settings.

**NOTE:** Changes made to the position flag are not saved until you click **OK** in the Flag dialog box ("Accessing the Flag Dialog Box" on page 57).

## Broadcasting to Servers

Analog users can simultaneously control more than one server in a system to be sure that all selected servers receive identical input. For each server receiving the broadcast, you can choose to broadcast keystrokes and mouse movements independently.

**NOTE:** During broadcast, any users connected to a broadcast server will be disconnected and unable to access any servers.

**NOTE:** You can broadcast to only one server per Expansion Module ("Installing the Expansion Module" on page 23) connection.

## Broadcasting Keystrokes

The keyboard statistics must be identical for all servers receiving a broadcast to interpret keystrokes identically. Specifically, the **Caps Lock** and **Num Lock** modes must be the same on all keyboards. While the HP KVM Server Console Switch attempts to send keystrokes to the selected servers simultaneously, some servers can inhibit and thereby delay the transmission.

## Broadcasting Mouse Movements

For the mouse to work accurately, all systems must have identical mouse drivers, desktops (such as identically placed icons), and video resolutions. In addition, the mouse must be in exactly the same place on all screens. Because these conditions are extremely difficult to achieve, broadcasting mouse movements to multiple systems can have unpredictable results.

## Accessing the Broadcast Dialog Box

From the Main dialog box ("Accessing the Main Dialog Box" on page 41), click **Setup>Broadcast**. The **Broadcast** dialog box is displayed.

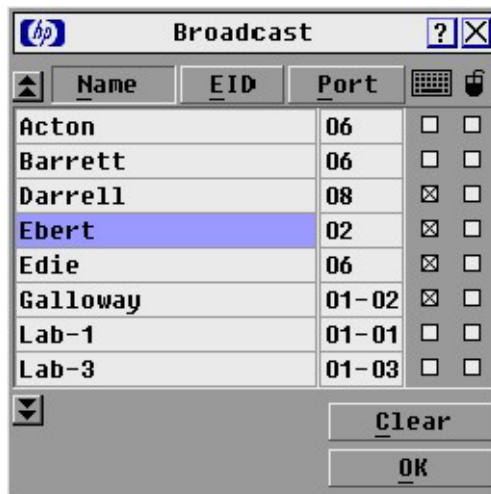

## Broadcasting Selected Servers

1. From the **Broadcast dialog box** ("Accessing the Broadcast Dialog Box" on page 59), select the keyboard and mouse checkboxes for the servers that are to receive the broadcast commands.

-or-

Press the **Up** or **Down Arrow** keys to move the cursor to the target server. Then press the **Alt + K** keys to select the keyboard checkbox and/or the **Alt + M** keys to select the mouse checkbox. Repeat for additional servers.

2. Click **OK** to save the settings and return to the **Setup** dialog box.
3. Click **X** or press the **Esc** key to return to the **Main** dialog box.
4. From the **Main** dialog box, click the **Commands dialog box** ("Accessing the Commands Dialog Box" on page 68), select **Broadcast Enable** to activate broadcasting.
5. From the user station, enter the information and/or perform the mouse movements you want to broadcast.

## Activating the Broadcast Dialog Box

To activate or deactivate broadcasting, from the Commands dialog box ("Accessing the Commands Dialog Box" on page 68), select or deselect **Broadcast Enable**.

## Setting Up a Scan Pattern

In Scan mode ("Activating Scan Mode" on page 62), the HP KVM Server Console Switch automatically scans port to port (server to server). You can select up to 16 servers from a list of all servers attached to the HP KVM Server Console Switch. You can display the list by either server name or EID number by clicking the appropriate button. Selecting the checkbox beside each server to be added to the scan list creates the scan list. The creation of a scan list does not start Scan mode. You must enable Scan mode through the **Scan Enable** checkbox on the Commands dialog box ("Accessing the Commands Dialog Box" on page 68).

## Accessing the Scan Dialog Box

From the Main dialog box ("Accessing the Main Dialog Box" on page 41), click **Setup>Scan**. The **Scan** dialog box is displayed.



## Adding Servers to the Scan List

- From the **Scan dialog box** ("Activating Scan Mode" on page 62), select the checkbox beside each server to be added to the scan list.  
-or-  
Double-click a server name or port.  
-or-  
Press the **Alt** key plus the number of the server you want to scan. You can select up to 16 servers.
- In the **Scan Time** box, enter the number of seconds (from 3 to 99) before the scan moves to the next server in the sequence.
- Click **OK** to save settings.  
-or-  
Click **Clear** to remove all servers from the scan list.

**IMPORTANT:** Selecting the checkbox beside each server to be added to the scan list creates the scan list. The creation of a scan list does not start the Scan mode. You must enable Scan mode through the **Scan Enable** checkbox on the **Commands** dialog box.

**NOTE:** If the user removes a server from the **Device Modify** dialog box later, the change can affect a custom scan pattern.

## Removing Servers from the Scan List

1. From the Scan dialog box ("Activating Scan Mode" on page 62), click the server to be removed.  
-or-  
Double-click a server name or port.  
-or-  
Click **Clear** to remove all servers from the scan list.
2. Click **OK** to save settings.

## Activating Scan Mode

1. From the Commands dialog box ("Accessing the Commands Dialog Box" on page 68), select **Scan Enable**.
2. Click **X** to close the **Commands** dialog box.

**NOTE:** The scanning begins as soon as you click **Scan**.

## Deactivating Scan Mode

If the OSD is open, select a server.

-or-

If the OSD is not open, move the mouse or press any key on the keyboard. Scanning stops at the currently selected server.

-or-

From the Commands dialog box ("Accessing the Commands Dialog Box" on page 68), deselect **Scan Enable**. Any active connections on the local port are disconnected.

## Setting Local Console Switch Security

The OSD enables you to set security on the local port consoles. You can establish a Screen Saver mode ("Activating Screen Saver Mode without Password Protection" on page 66) that engages after the HP KVM Server Console Switch remains unused for a user-definable time delay. When engaged, the HP KVM Server Console Switch remains locked until any key is pressed or the mouse is moved. Then you can enter the password to log in.

Use the **Security dialog box** ("Accessing the Security Dialog Box" on page 64) to lock your HP KVM Server Console Switch with password protection, set or change the password, and enable the screen saver.

**NOTE:** If a password has been previously set, you must enter the password before you can access the **Security** dialog box.

## Accessing the Security Dialog Box

From the Main dialog box ("Accessing the Main Dialog Box" on page 41), click **Setup>Security**. The **Security** dialog box is displayed.



## Changing the Password

1. From the Security dialog box ("Accessing the Security Dialog Box" on page 64), single-click in the **New** field and press the **Enter** key if the OSD is not open, or double-click the **New** field.
2. Enter the new password in the **New** field, and then press the **Enter** key.
3. In the **Repeat** field, reenter the password and press the **Enter** key.
4. Click **OK** to change the password.

**IMPORTANT:** A valid password must be alphanumeric and be 5 to 15 characters in length. Permitted characters are case-sensitive and can consist of A–Z, 0–9, spaces, and hyphens.

## Setting Password Protection

1. From the Security dialog box ("Accessing the Security Dialog Box" on page 64), set your password as described in the previous procedure.



2. Select **Enable Screen Saver**.
3. Enter the number of minutes for **Time Delay** (from 1 to 99) to delay activation of password protection and the screen saver feature.
4. For **Mode**, select **Energy** if your monitor is Energy Star® compliant. Otherwise, select **Screen**.
5. (Optional) Click **Test** to activate the screen saver test, which lasts 10 seconds and returns you to the **Security** dialog box.
6. Click **OK** to save settings.



**CAUTION:** Monitor damage can result from the use of energy mode with monitors not compliant with Energy Star®.

## Logging On to the KVM Server Console Switch

1. Press any key on the keyboard, or move the mouse. The **Password** dialog box is displayed.
2. Enter the password, and then click **OK**.
3. Press the **Print Scrn** key.

## Removing the Password Protection

1. From the Main dialog box ("Accessing the Main Dialog Box" on page 41), click **Setup>Security**. The **Password** dialog box is displayed.
2. Enter the password, and then click **OK**.
3. In the **Security** dialog box, click the **New** field and press the **Enter** key.  
-or-  
Double-click the **New** field, leave the **New** field blank, and press the **Enter** key.
4. Click the **Repeat** field and press the **Enter** key.  
-or-  
Double-click the **Repeat** field, leave the **Repeat** field blank, and press the **Enter** key.

5. Click **OK** if you want to eliminate the password.

## Exiting Screen Saver Mode

To exit the **Screen Saver** mode, press any key or move the mouse. The Main dialog box ("Accessing the Main Dialog Box" on page 41) is displayed.

## Activating Screen Saver Mode without Password Protection

1. If your HP KVM Server Console Switch does not require a password to gain access to the Security dialog box ("Accessing the Security Dialog Box" on page 64), proceed to step 2.  
-or-  
If your HP KVM Server Console Switch is password protected, see the previous procedure, then go to step 2.
2. Select **Enable Screen Saver**.
3. Enter the number of minutes for **Inactivity Time** (1 to 99) to delay activation of the screen saver.
4. Select **Energy** if your monitor is Energy Star® compliant. Otherwise, select **Screen**.
5. (Optional) Click **Test** to activate the screen saver test, which lasts 10 seconds, then returns you to the **Security** dialog box.
6. Click **OK** to save settings.



**CAUTION:** Monitor damage can result from the use of energy mode with monitors not compliant with Energy Star®.

**NOTE:** No server is selected after the activation of the screen saver mode disconnects the user from a server. The status flag displays **Free**.

## Deactivating the Screen Saver

1. From the Security dialog box ("Accessing the Security Dialog Box" on page 64), clear **Enable Screen Saver**.
2. Click **OK** to save settings.

To immediately activate the screen saver, press the **Print Scrn** key, and then press the **Pause** key. This command only works when the user is connected to a server.

## Changing the Switch Mode

You can connect to attached servers using two methods:

- Preemptive—Allows any user to select any server at any time; a request from another user disconnects the current user without warning
- Cooperative—Maintains the current user connection; the current user will not be disconnected if another user requests connection

## Accessing the Switch Dialog Box

1. From the Main dialog box ("Accessing the Main Dialog Box" on page 41), click **Setup>Switch**. The **Switch** dialog box is displayed.

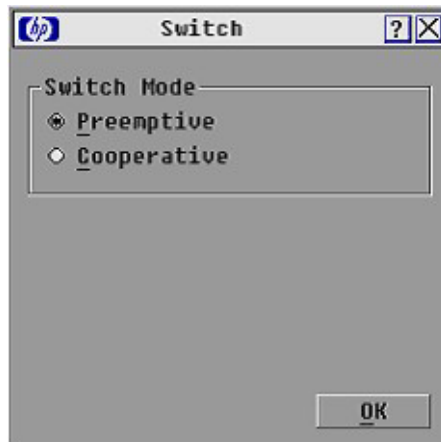

2. Select either **Preemptive** or **Cooperative**.
  3. Click **OK** to save settings.
- or-
- Click **X** to exit, or press the **Esc** key to exit without saving settings.

## Managing Server Tasks Using the OSD

You can manage the HP KVM Server Console Switch system from the Commands dialog box ("Accessing the Commands Dialog Box" on page 68) with the OSD, including engaging Scan mode ("Activating Scan Mode" on page 62) and Broadcast mode ("Activating the Broadcast Dialog Box" on page 60), managing user connections, running diagnostics, and updating your firmware.

Feature	Purpose
<b>Broadcast Enable</b>	Begins broadcasting to your servers. Configures a server list for broadcasting under the <b>Setup</b> dialog box.
<b>Scan Enable</b>	Begins scanning your servers. Sets up a list for scanning in the <b>Setup</b> dialog box.
<b>IA Status</b>	Upgrades multiple Interface Adapters simultaneously.
<b>Display Versions</b>	Displays version information for the console switch, and firmware information for individual Interface Adapters. Enables you to upgrade individual Interface Adapter firmware.
<b>Run Diagnostics</b>	Validates the integrity of your system, including memory, firmware CRC, comm interfaces, switch controller, local and remote video, and Interface Adapters.

### Accessing the Commands Dialog Box

From the Main dialog box ("Accessing the Main Dialog Box" on page 41), click **Commands**. The **Commands** dialog box is displayed.



## Running System Diagnostics

Clicking **Run Diagnostics** ("Activating Run Diagnostics" on page 71) runs a command to check the main board functions subsystems (memory, intra-board communications, HP KVM Server Console Switch control, and the video channels) for each system controller.

<b>Test</b>	<b>Description</b>
<b>Memory Test</b>	Reports the condition of the main board RAM. This indicator displays the results of the memory tests performed at system reboot.
<b>Firmware CRCs</b>	Validates the current firmware images stored in the system FLASH by comparing a CRC value on each image and comparing those results to the expected values.
<b>Comm Interfaces</b>	Verifies the intra-board communication subsystems are accessible and functional by querying the communications controller and performing basic register level tests.
<b>Switch Controller</b>	Verifies the switch matrix controller is accessible and functional by querying the switch matrix controller and performing basic register level tests.
<b>Local Video</b>	Verifies that all the video channel subsystems are accessible, functional, and performing basic register level tests.
<b>On-line IAs</b>	Indicates the total number of currently connected and powered Interface Adapters.
<b>Off-line IAs</b>	Indicates the number of Interface Adapters that have been connected successfully in the past and are powered down.
<b>Suspect IAs</b>	Indicates the number of Interface Adapters that have been detected but are either unavailable for connection or have dropped packets during the ping tests.

## Activating Run Diagnostics

1. From the Main dialog box ("Accessing the Main Dialog Box" on page 41), click **Commands>Run Diagnostics**. A warning message is displayed indicating that all users will be disconnected.



2. Click **OK** to begin. All users are disconnected, and the **Diagnostics** dialog box is displayed.

-or-

Click **X** or press the **Esc** key to exit the dialog box without running a diagnostic test.

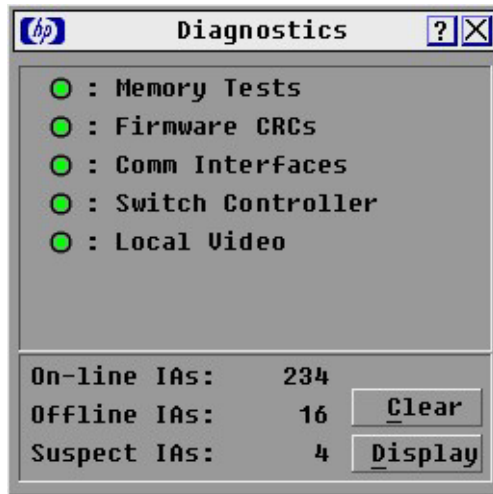

3. As each test is finished, a pass or fail symbol is displayed.  
A passed test is indicated with a green circle, and a failed test is indicated by a red X. The test is complete when the last test symbol displays.
4. (Optional) If you have any offline Interface Adapters, you can click **Clear** to remove them from the list.
5. (Optional) If you have any suspect Interface Adapters, you can click **Display**. The **Suspect Interface Adapter** dialog box is displayed.

## Displaying Version Information

The **Version dialog box** ("Accessing the Version Dialog Box" on page 73) enables you to view the HP KVM Server Console Switch versions, as well as keyboard and mouse information for the currently selected server.



## Accessing the Version Dialog Box

**NOTE:** Provide the application version number when communicating with HP customer service centers.

1. From the Main dialog box ("Accessing the Main Dialog Box" on page 41), click **Commands>Version**. The **Version** dialog box is displayed. The top half of the box lists the subsystem versions in the HP KVM Server Console Switch.

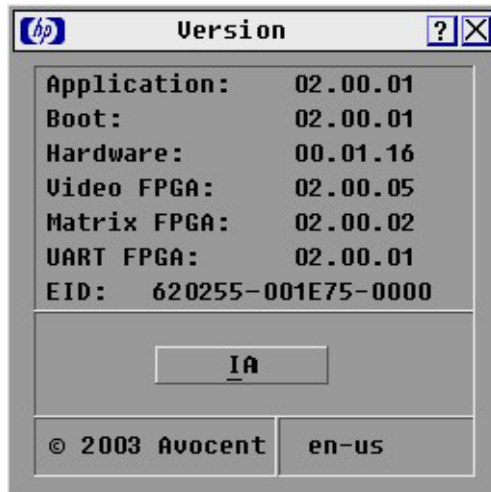

- Click **IA** to access the **IA Selection** dialog box to view individual Interface Adapter cable version information. The **IA Selection** dialog box is displayed.

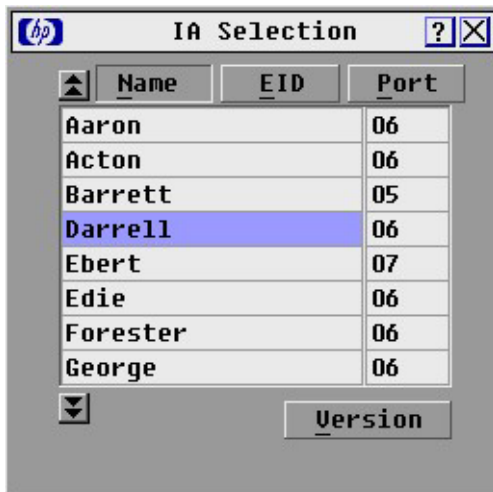

- To view the selected Interface Adapter cable, click **Version**. The **IA Version** dialog box is displayed.

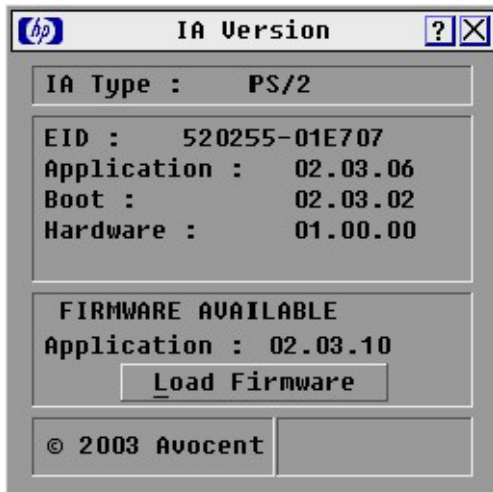

- Click **X** to exit.

# Updating the Firmware

## In This Section

Updating the Console Switch Firmware.....	75
Updating the Interface Adapter Firmware Simultaneously .....	76
Updating the Interface Adapter Firmware Individually .....	76

## Updating the Console Switch Firmware

**NOTE:** The PC or laptop used to upgrade the firmware must be running Microsoft® Windows NT® or greater.

1. Connect the serial download cable to the serial download connector on the PC (must be running Windows®) and to the serial download connector ("Components" on page 17) on the rear panel of the HP KVM Server Console Switch.
2. Go to the folder where the firmware files are saved and run the WUpdateHP.exe file.

**NOTE:** The three .bin files must be in the same folder as the WUpdateHP.exe file.

3. Select which language to install and enter the serial port number of the server to which the HP KVM Server Console Switch is attached.
4. Click **Load**. The update process begins.

The update process has three updates—Loading Application Firmware, Loading Graphics Chip, and Loading System Data. You see a progress bar for each of those three updates. The firmware update is not done until all of the updates have been loaded. When the firmware is updated, the following message indicating "Update Complete" is displayed.

5. Click **Done**.

## Updating the Interface Adapter Firmware Simultaneously

1. From the Main dialog box ("Accessing the Main Dialog Box" on page 41), click **Commands>IA Status**. The **IA Status** dialog box is displayed.
2. Select **PS/2** or **USB**, then click **Upgrade**. The **IA Upgrade** dialog box is displayed.

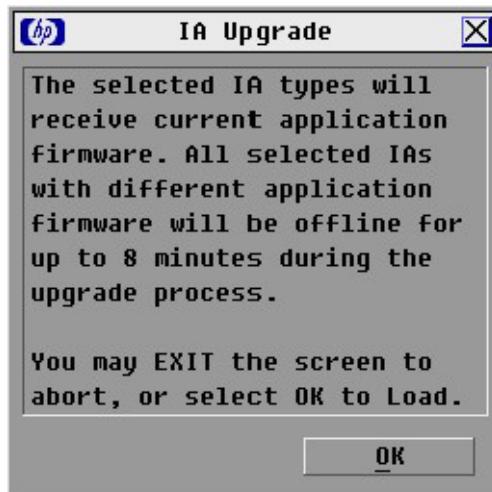

3. Click **OK** to save settings.
4. Press the **Esc** key to return to the Main dialog box ("Accessing the Main Dialog Box" on page 41). The OSD indicators are displayed as yellow while the upgrade is in progress. The indicators change to red and then to green when the upgrade is complete.

**NOTE:** Wait until the OSD indicators are displayed as green before continuing.

## Updating the Interface Adapter Firmware Individually

1. From the Main dialog box ("Accessing the Main Dialog Box" on page 41), click **Commands>Version**. The **Version** dialog box is displayed.

- Click **IA**. The **IA Selection** dialog box is displayed.

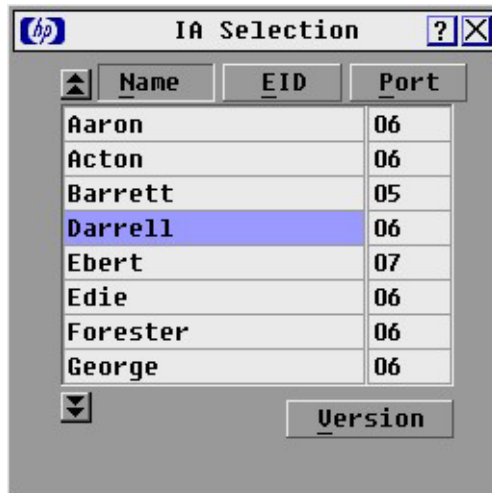

- Select the individual Interface Adapter, and click **Version**. The **IA Version** dialog box is displayed.
- Click **Load Firmware**.



# Troubleshooting

## In This Section

Troubleshooting Table.....	80
Connection Length Table .....	81

## Troubleshooting Table

Problem	Troubleshooting
<p>The local user cannot view the OSD copyright notice.</p> <p>-or-</p> <p>The OSD copyright notice is distorted.</p>	<ul style="list-style-type: none"> <li>• Be sure that the power source is valid.</li> <li>• Be sure that the cables are connected properly.</li> <li>• Be sure that the monitor is valid.</li> </ul>
<p>The local user cannot view the OSD flag.</p>	<p>Preview the preferences selected in the OSD to determine if the local port display has been disabled or set to time out. If the preferences are set to not display the OSD flag or to have the flag time out, then the OSD flag does not display.</p>
<p>The local user cannot activate or view the OSD, and the OSD flag disappears.</p>	<p>Be sure that the local port keyboard is connected properly and that the keyboard is valid.</p>
<p>The OSD is distorted or not readable on the local port video display.</p>	<p>Be sure that the monitor supports refresh rate to which target server is set.</p>
<p>The activity indicator light ("Components" on page 17) does not display when the HP KVM Server Console Switch is powered on.</p>	<ul style="list-style-type: none"> <li>• Be sure that the HP KVM Server Console Switch is powered on and that the power source is valid.</li> <li>• Be sure that the cables are connected properly.</li> </ul>
<p>The system does not recognize the HP IP Console Switch.</p>	<p>All HP IP Console Switches must be upgraded with SoftPaq firmware version 2.1.1 or later.</p>
<p>The system does not recognize the Compaq Server Console Switch.</p>	<p>All Compaq Server Console Switches must be upgraded with SoftPaq firmware version 2.1.0 or later.</p>
<p>An Expansion Module ("Installing the Expansion Module" on page 23) is not being recognize by a Compaq Server Console Switch.</p>	<p>An Expansion Module ("Installing the Expansion Module" on page 23) is considered a level of cascading ("Cascading Console Switches" on page 27) and therefore cannot be used in combination with a cascaded Compaq Server Console Switch.</p>
<p>The HP KVM Server Console Switch system is inaccessible after losing the password.</p>	<p>Call the HP Customer Support Center for more detailed instructions.</p>
<p>The OSD is inaccessible.</p>	<p>Press the <b>Ctrl</b> key twice.</p>
<p>Servers are still listed although they have been disconnected.</p>	<p>From the <b>Diagnostics dialog box</b> ("Activating Run Diagnostics" on page 71), click <b>Clear</b>.</p>



Problem	Troubleshooting
Video displays all green or red.	<ul style="list-style-type: none"> <li>• Check the UTP CAT5 cable for breaks or bad crimps.</li> <li>• Check the VGA connection for a bent pins.</li> </ul>
The Screen Saver does not turn on.	Be sure to click <b>OK</b> to confirm the screen saver selection. Click <b>X</b> or press <b>Esc</b> to cancel the command.
The video resolution is distorted.	For more information, refer to the Connection Length Table (on page 81).

## Connection Length Table

The HP KVM Server Console Switch offers optimum video performance when the distance between the server and console switch is 50 feet or less (1280 x 1024 at 75 Hz). The system is capable of operation at distances up to 100 feet at reduced video resolutions (800 x 640 at 60 Hz, worst case).

	<b>1280 x 1024</b>	<b>1024 x 768</b>	<b>800 x 640</b>
50 feet	X	X	X
75 feet			X
100 feet			X



---

# Technical Support

## In This Section

HP Contact Information.....	83
Before You Contact HP.....	83

## HP Contact Information

For the name of the nearest HP authorized reseller:

- In the United States, call 1-800-345-1518.
- In Canada, call 1-800-263-5868.
- In other locations, refer to the HP website (<http://www.hp.com>).

For HP technical support:

- In North America, call the HP Technical Support Phone Center at 1-800-652-6672. This service is available 24 hours a day, 7 days a week. For continuous quality improvement, calls may be recorded or monitored.
- Outside North America, call the nearest HP Technical Support Phone Center. For telephone numbers for worldwide Technical Support Centers, refer to the HP website (<http://www.hp.com>).

## Before You Contact HP

Be sure to have the following information available before you call HP:

- Technical support registration number (if applicable)
- Product serial number
- Product model name and number
- Applicable error messages
- Add-on boards or hardware

- Third-party hardware or software
- Operating system type and revision level

---

# Regulatory Compliance Notices

## In This Section

Regulatory Compliance Identification Numbers .....	85
Federal Communications Commission Notice .....	86
Declaration of Conformity for Products Marked with the FCC Logo, United States Only ...	87
Modifications .....	88
Cables .....	88
Canadian Notice (Avis Canadien) .....	88
European Union Notice .....	89
Japanese Notice .....	89
BSMI Notice.....	90
Korean Notices .....	90

## Regulatory Compliance Identification Numbers

For the purpose of regulatory compliance certifications and identification, this product has been assigned a unique series number. The series number can be found on the product nameplate label, along with all required approval markings and information. When requesting compliance information for this product, always refer to this series number. The series number is not the marketing name or model number of the product.

## Federal Communications Commission Notice

Part 15 of the Federal Communications Commission (FCC) Rules and Regulations has established Radio Frequency (RF) emission limits to provide an interference-free radio frequency spectrum. Many electronic devices, including computers, generate RF energy incidental to their intended function and are, therefore, covered by these rules. These rules place computers and related peripheral devices into two classes, A and B, depending upon their intended installation. Class A devices are those that may reasonably be expected to be installed in a business or commercial environment. Class B devices are those that may reasonably be expected to be installed in a residential environment (for example, personal computers). The FCC requires devices in both classes to bear a label indicating the interference potential of the device as well as additional operating instructions for the user.

### FCC Rating Label

The FCC rating label on the device shows the classification (A or B) of the equipment. Class B devices have an FCC logo or ID on the label. Class A devices do not have an FCC logo or ID on the label. After you determine the class of the device, refer to the corresponding statement.

### Class A Equipment

This equipment has been tested and found to comply with the limits for a Class A digital device, pursuant to Part 15 of the FCC Rules. These limits are designed to provide reasonable protection against harmful interference when the equipment is operated in a commercial environment. This equipment generates, uses, and can radiate radio frequency energy and, if not installed and used in accordance with the instructions, may cause harmful interference to radio communications. Operation of this equipment in a residential area is likely to cause harmful interference, in which case the user will be required to correct the interference at personal expense.

## Class B Equipment

This equipment has been tested and found to comply with the limits for a Class B digital device, pursuant to Part 15 of the FCC Rules. These limits are designed to provide reasonable protection against harmful interference in a residential installation. This equipment generates, uses, and can radiate radio frequency energy and, if not installed and used in accordance with the instructions, may cause harmful interference to radio communications. However, there is no guarantee that interference will not occur in a particular installation. If this equipment does cause harmful interference to radio or television reception, which can be determined by turning the equipment off and on, the user is encouraged to try to correct the interference by one or more of the following measures:

- Reorient or relocate the receiving antenna.
- Increase the separation between the equipment and receiver.
- Connect the equipment into an outlet on a circuit that is different from that to which the receiver is connected.
- Consult the dealer or an experienced radio or television technician for help.

## Declaration of Conformity for Products Marked with the FCC Logo, United States Only

This device complies with Part 15 of the FCC Rules. Operation is subject to the following two conditions: (1) this device may not cause harmful interference, and (2) this device must accept any interference received, including interference that may cause undesired operation.

For questions regarding this product, contact us by mail or telephone:

- Hewlett-Packard Company  
P. O. Box 692000, Mail Stop 530113  
Houston, Texas 77269-2000
- 1-800-652-6672 (For continuous quality improvement, calls may be recorded or monitored.)

For questions regarding this FCC declaration, contact us by mail or telephone:

- Hewlett-Packard Company  
P. O. Box 692000, Mail Stop 510101  
Houston, Texas 77269-2000
- 1-281-514-3333

To identify this product, refer to the part, series, or model number found on the product.

## Modifications

The FCC requires the user to be notified that any changes or modifications made to this device that are not expressly approved by Hewlett-Packard Company may void the user's authority to operate the equipment.

## Cables

Connections to this device must be made with shielded cables with metallic RFI/EMI connector hoods in order to maintain compliance with FCC Rules and Regulations.

## Canadian Notice (Avis Canadien)

### Class A Equipment

This Class A digital apparatus meets all requirements of the Canadian Interference-Causing Equipment Regulations.

Cet appareil numérique de la classe A respecte toutes les exigences du Règlement sur le matériel brouilleur du Canada.

### Class B Equipment

This Class B digital apparatus meets all requirements of the Canadian Interference-Causing Equipment Regulations.

Cet appareil numérique de la classe B respecte toutes les exigences du Règlement sur le matériel brouilleur du Canada.



## European Union Notice



Products bearing the CE marking comply with the EMC Directive (89/336/EEC) and the Low Voltage Directive (73/23/EEC) issued by the Commission of the European Community and, if this product has telecommunication functionality, the R&TTE Directive (1999/5/EC).

Compliance with these directives implies conformity to the following European Norms (in parentheses are the equivalent international standards and regulations):

- EN 55022 (CISPR 22)—Electromagnetic Interference
- EN55024 (IEC61000-4-2, 3, 4, 5, 6, 8, 11)—Electromagnetic Immunity
- EN61000-3-2 (IEC61000-3-2)—Power Line Harmonics
- EN61000-3-3 (IEC61000-3-3)—Power Line Flicker
- EN 60950 (IEC60950)—Product Safety

## Japanese Notice

ご使用になっている装置にVCCIマークが付いていましたら、次の説明文をお読み下さい。

この装置は、情報処理装置等電波障害自主規制協議会（VCCI）の基準に基づくクラスB情報技術装置です。この装置は、家庭環境で使用することを目的としていますが、この装置がラジオやテレビジョン受信機に近接して使用されると、受信障害を引き起こすことがあります。取扱説明書に従って正しい取り扱いをして下さい。

VCCIマークが付いていない場合には、次の点にご注意下さい。

この装置は、情報処理装置等電波障害自主規制協議会（VCCI）の基準に基づくクラスA情報技術装置です。この装置を家庭環境で使用すると電波妨害を引き起こすことがあります。この場合には使用者が適切な対策を講ずるよう要求されることがあります。

## BSMI Notice

警告使用者:

這是甲類的資訊產品，在居住的環境中使用時，可能會造成射頻干擾，在這種情況下，使用者會被要求採取某些適當的對策。

## Korean Notices

### Class A Equipment

#### A급 기기 (업무용 정보통신기기)

이 기기는 업무용으로 전자파적합등록을 한 기기이오니 판매자 또는 사용자는 이 점을 주의하시기 바라며, 만약 잘못판매 또는 구입하였을 때에는 가정용으로 교환하시기 바랍니다.

### Class B Equipment

#### B급 기기 (가정용 정보통신기기)

이 기기는 가정용으로 전자파적합등록을 한 기기로서 주거지역에서는 물론 모든지역에서 사용할 수 있습니다.

# Acronyms and Abbreviations

**CRC**

cyclic redundant checks

**EID**

electronic identification number

**IA**

Interface Adapter

**KVM**

keyboard, video, and mouse

**OSD**

on-screen display

**USB**

universal serial bus

**UTP**

unshielded twisted pair

**VDC**

voltage direct-current

**VGA**

video graphics array

# Index

## A

accessing the Broadcast dialog box 59  
 accessing the Commands dialog box 68  
 accessing the Devices dialog box 51  
 accessing the Flag dialog box 57  
 accessing the Main dialog box 41  
 accessing the Menu dialog box 55  
 accessing the Names dialog box 50  
 accessing the Scan dialog box 60  
 accessing the Security dialog box 64  
 accessing the Setup dialog box 49  
 accessing the Switch dialog box 67  
 accessing the Version dialog box 73  
 activating broadcasting 60  
 activating Run Diagnostics 71  
 activating Scan mode 62  
 activating Screen Saver mode 66  
 adding server names 19  
 adding servers to the Scan list 61  
 additional information 83  
 assigning device types 51  
 assigning server names 50  
 authorized reseller 83

## B

Broadcast dialog box 58, 59, 60  
 broadcasting to servers 58  
 BSMI notice 90

## C

cables 88  
 Canadian Notice 88  
 cantilever 13, 15  
 cascaded console switch configurations 32, 35, 39  
 cascading console switches 27, 29, 33, 36

changing the display behavior 55  
 changing the password 64  
 changing the Switch mode 67  
 Commands dialog box 68  
 Compaq Server Console Switch 28, 33, 35  
 compatible models 27  
 components 17  
 configuration of system 17, 21, 26, 32, 35, 39  
 configuring servers for soft switching 46  
 configuring the Setup dialog box 49  
 connection length 81  
 controlling the Status flag 56

## D

deactivating Scan mode 62  
 deactivating Screen Saver mode 66  
 Declaration of Conformity 87  
 Devices dialog box 51, 52, 54  
 displaying the status flag 57  
 displaying version information 72

## E

European Union notice 89  
 exiting Screen Saver mode 66  
 Expansion Module 23, 24, 25, 26

## F

Federal Communications Commission (FCC)  
     Notice 86, 87, 88  
 firmware, updating 75  
 Flag dialog box 56, 57

## H

HP IP Console Switch 29, 36, 39

## I

identification number, server 85  
 installation checklist 7  
 installing the Expansion Module 23

installing the Interface Adapter 21  
installing the KVM Server Console Switch 7  
Interface Adapter 21, 76  
Interface Adapter configuration 21

## J

Japanese notice 89

## K

kit contents 7  
kit contents, Expansion Module 23

## L

local port operation 41  
logging on to the console switch 65

## M

Main dialog box 41, 42, 44, 45, 46  
managing routine tasks for servers 50  
managing server tasks 68  
Menu dialog box 55, 56  
modifying device types 52

## N

Names dialog box 50

## O

optional items 8  
OSD navigation keys 48  
overview of installation process 7

## P

port, viewing and selecting 42  
powering-on sequence 17

## R

rack mounting configurations 8

rack mounting hardware 7  
regulatory compliance notices 85  
removing password protection 65  
removing servers from the Scan list 62  
required information 83  
required items not included 8  
required tools 8  
Run Diagnostics command 69, 71

## S

Scan dialog box 60, 61, 62  
Scan list 61  
Scan mode 62  
screen delay time 56  
Screen Saver mode 66  
Security dialog box 63, 64, 65, 66  
selecting servers 45  
selecting the display order of servers 55  
series number 85  
server names 50  
server states 44  
server, viewing and selecting 42  
setting a screen delay time 56  
setting local console switch security 63, 64, 65, 66  
setting password protection 64  
setting up a scan pattern 60  
Setup menu 49, 50  
side-mount 9, 10, 24  
soft switching 46, 47  
standard-mount (1U) 12  
Switch dialog box 67  
Switch mode 67

## T

technical support 83  
telephone numbers 83  
troubleshooting 80

## U

updating Interface Adapter firmware 76  
updating the firmware 75

using basic OSD navigation keys 48

## **V**

velcro-mount 26

Version dialog box 72, 73

viewing and selecting ports and servers 42