

Make Life Smarter and Easier

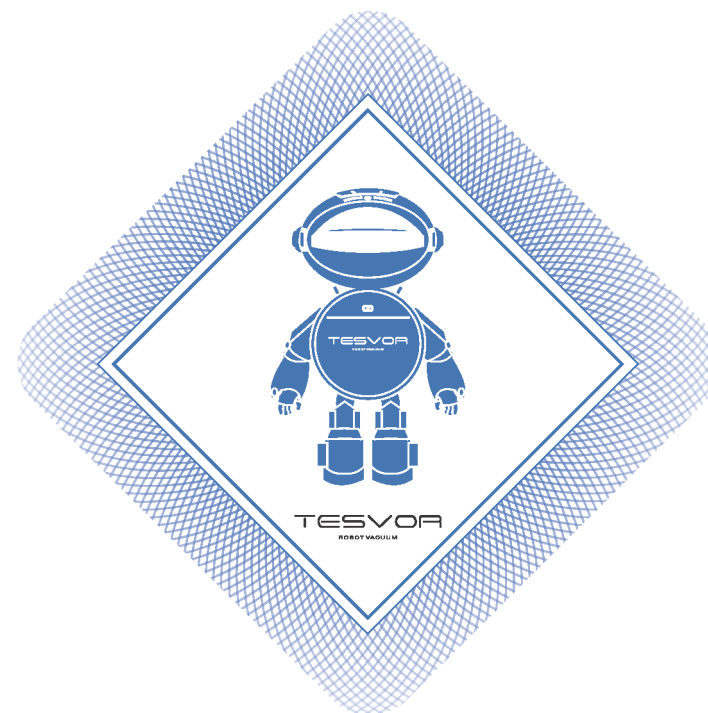

User Manual

Importer: Tesvor, Shenzhen Tian You Intelligence Co., Ltd.
Address: 2/F Liangji Business Building, Donghuan 1ST Road,
Fukang Community, Longhua District, Shenzhen, China
Company Website: <http://www.tesvor.com>
Customer Contact: service@tesvor.com
Manufacturer: Shenzhen Hua Xin Information Technology Co., Ltd.
Address: Section A, 10/F, Block 1, No.7 Industrial Park, Yulu Community,
Yutang, Guangming New District, Shenzhen, China

Make Life Smarter and Easier

Greetings from Tesvor!

Thank you for purchasing Tesvor smart cleaning robot.

We hope that our product will bring you a smarter and more convenient lifestyle!

If you encounter any problem not mentioned herein, please contact: service@tesvor.com

For more details, please visit our official website: <http://www.tesvor.com>

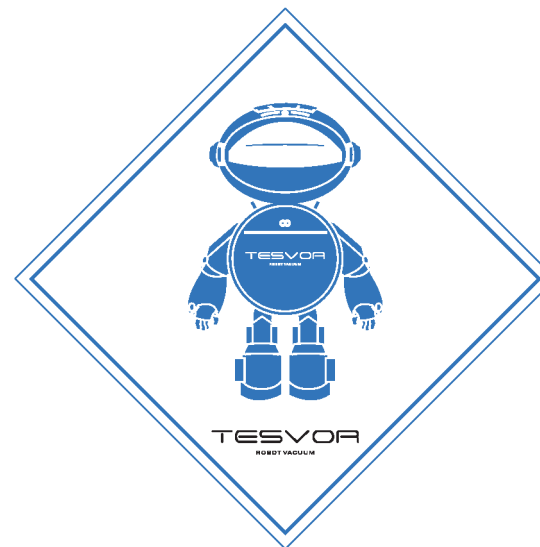
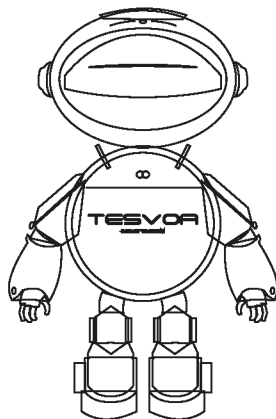

TESVOR

X500 Smart Robot Vacuum

FCC warning:

Note: This equipment has been tested and found to comply with the limits for a Class B digital device, pursuant to part 15 of the FCC Rules. These limits are designed to provide reasonable protection against harmful interference in a residential installation. This equipment generates, uses and can radiate radio frequency energy and, if not installed and used in accordance with the instructions, may cause harmful interference to radio communications. However, there is no guarantee that interference will not occur in a particular installation. If this equipment does cause harmful interference to radio or television reception, which can be determined by turning the equipment off and on, the user is encouraged to try to correct the interference by one or more of the following measures:

- Reorient or relocate the receiving antenna.
- Increase the separation between the equipment and receiver.
- Connect the equipment into an outlet on a circuit different from that to which the receiver is connected.
- Consult the dealer or an experienced radio/TV technician for help.

Modification: Any changes or modifications not expressly approved by the grantee of this device could void the user's authority to operate the device.

RF radiation exposure statement

The Robotic Vacuum Cleaner complies with FCC RF radiation exposure limits set forth for an uncontrolled environment. Caution: To maintain the compliance with the FCC's RF exposure guideline, install the Robotic Vacuum Cleaner at least 7.9" (20 cm) from ALL persons. The transmitter of this device must not be co-located or operating in conjunction with any other antenna or transmitter.

1. Welcome

2. Safety Instructions

3. Product Components

- 3.1 Names of Parts
- 3.2 Product Specifications
- 3.3 Product Characteristics

4. Instructions for Use

- 4.1 Remote Control Instructions
- 4.2 Operating Instructions

5. Product Maintenance

- 5.1 Side Brush Cleaning and Replacement
- 5.2 Cleaning of Dust Box and Filter
- 5.3 Maintenance of Rolling Brush Components
- 5.4 Maintenance of Other Components
- 5.5 Replaceable Modules

6. Common Faults

Before using this product, please read the safety instructions below and follow all the routine safety precautions.

Please read the Instructions carefully and keep them for future reference. Any operation that does not conform to the Instructions may cause damage to the product.

Safety Considerations of Main Body and Accessories

⚠ Warning

01. Do not disassemble, repair or refit the product without authorization; otherwise it may damage the product or pose a hazard.
02. Do not use the product in an environment with risk of fire or explosion.
03. This product can only use the original power adapter; otherwise the product may be damaged or catch on fire.
04. Do not stand or sit on this product; doing so could damage the product or cause it to fall over.
05. When the metal part of the power plug is dusty, please wipe it with a dry cloth.
06. The power adapter is applied to a 100-240V AC voltage. Please plug into the socket properly and keep away from children.
07. Do not wash or soak the main body and electronic accessories in water; otherwise the product may be damaged by a short circuit.
08. Do not damage, load weight on, heat, pull, or bend it.
09. During cleaning, please pay attention to the safety of toddlers and elders at home to avoid tripping, and please do not touch the wheel and side brush to avoid injury. (Please pay special attention to toddlers).
10. This product is for home use. Please do not use it outdoors.
11. Do not allow metal and conductive materials to come in contact with the battery; doing so may cause a short circuit.

⚠ Attention

01. Do not touch the product with wet hands; doing so may cause an electric shock.
02. Please do not place the product in places where it could easily fall, such as tables, chairs, high platforms in room, etc.
03. The product has a sophisticated design and should be protected from

6. Common Faults

Faults	Possible Reasons	Solutions
The robot cannot be charged.	<ol style="list-style-type: none"> 1. The electrodes between the main body and the charging base are not contacted properly. 2. The charging base is switched off while the robot is switched on, which leads to the loss of power. 	<ol style="list-style-type: none"> 1. Make sure that the electrodes between the main body and the charging base are properly contacted. 2. Keep charging the robot when it is not working to better prepare for next cleaning assignment.
The robot is stuck during work.	The robot may be stuck by wires/cables on the ground, hanging curtains or obstacles around the carpets.	The robot will try to get itself out automatically. However, please help it manually if it fails.
The robot goes back to recharge without finishing the cleaning work.	<ol style="list-style-type: none"> 1. The robot detects that the power may not be enough and automatically goes back to recharge. 2. The robot works at different speeds on different floor types. For example, it works longer on wood floors than on carpets. 	<ol style="list-style-type: none"> 1. Charge the robot. 2. The length of working time varies because of the complexities of room environments, the amount of garbage and different cleaning modes.
The robot does not perform cleaning work automatically as scheduled.	<ol style="list-style-type: none"> 1. The robot is not switched on and the robot cannot perform cleaning work as scheduled when it is powered off. 2. The power level of the robot is too low to work. 3. The robot is stuck or twined by obstacles. 	<ol style="list-style-type: none"> 1. Turn on the robot. 2. Keep charging the robot when it is not working to better prepare for next cleaning assignment. 3. Turn off the robot and clean the dust box. Then turn over the robot to clean its components, such as wheels and side brushes.
Remote control malfunctions. (effective range: 16.3 ft).	<ol style="list-style-type: none"> 1. The remote control is short of or out of power. 2. The robot is short of or out of power. 3. The infrared ray is blocked because the infrared emitter on the remote control or the infrared receiver on the robot is contaminated. 4. Interference emitted by other devices that exist nearby. 	<ol style="list-style-type: none"> 1. Change the batteries and install the batteries correctly. 2. Make sure that the robot is switched on with enough power for operation. 3. Wipe the infrared emitter on the remote control or the infrared receiver on the robot with a clean cotton cloth. 4. Avoid using the remote control near other infrared devices.

Note: If the above methods cannot solve the problem, please reboot the robot. If the problem cannot be solved by reboot, please contact service@tesvor.com

5.5 Replaceable Modules

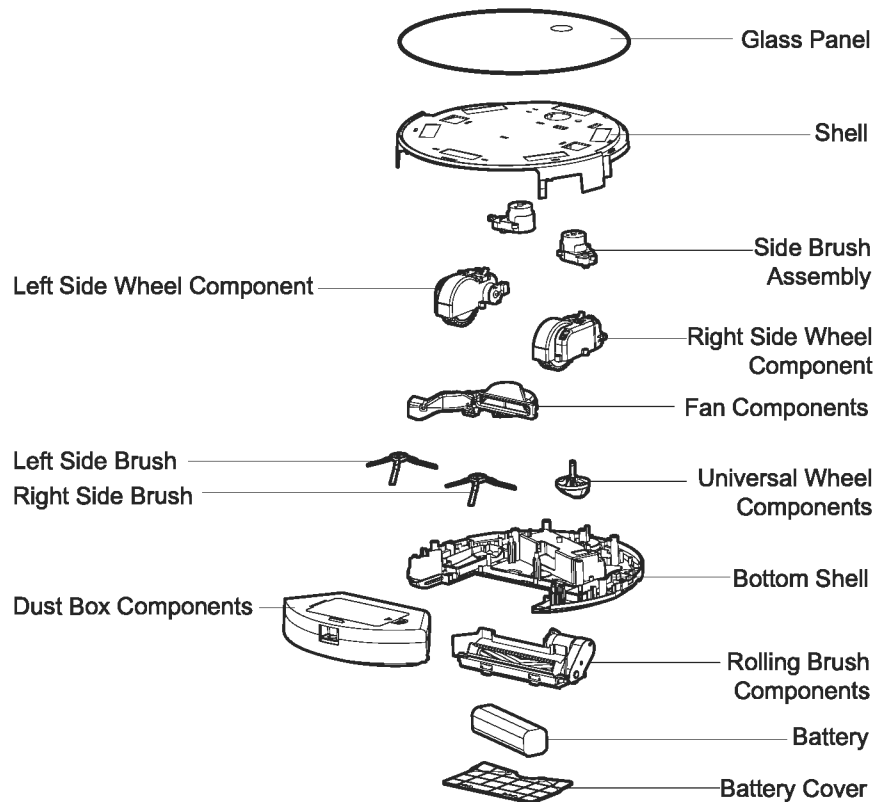

Range of application:

The product is suitable for cleaning houses, hotel rooms, and small offices and provides good cleaning for various carpets (with carpet wool length less than 0.6 inch), wooden floors, hard floors, floor tiles, etc.

long-term exposure to sunlight.

04. Please do not use the product in humid environments, such as bathrooms.
05. Please do not place the product near cigarette butts, lighters or other open fires.
06. Please clean the product after the end of charging.
07. Please turn off the power switch on the side of the robot when the product is out of service for a long time.
08. Please check carefully to see if the power adapter is connected to the socket prior to use, to avoid damage to the robot.
09. Before using the product, please remove all vulnerable items on the floor, such as glass, lamps, and items such as wires and curtains that may entangle with the side brush and suction passages.
10. When the dust box is full, please empty the garbage before using again.
11. Please do not use the robot to clean construction waste.
12. The operating temperature of the product ranges from 0 degrees Celsius to 40 degrees Celsius; please do not use it in a high temperature environment.
13. Before the product is scrapped, please remove the battery from the robot. When you remove the battery, please ensure that the product is not connected to a power supply. Please recycle the battery safely for environmental protection.

Safety Considerations for Rechargeable Battery

⚠ Danger

01. Always use a dedicated battery adapter to avoid leakage, heating or rupture.
02. Do not short-circuit the battery or remove the battery; doing so may cause leakage, heating or rupture.
03. Do not transport or preserve with necklaces, hairpins and other metal objects; doing so may lead to short circuit, resulting in leakage, heating or rupture.
04. Do not burn or heat the battery; doing so may cause leakage, heating or rupture.

① Attention

- 01.If abnormal overheating is discovered during charging, stop using it immediately to avoid leakage, heating or rupture.
- 02.To prolong the service life of the battery, please remove the battery and place it in a cool, dry environment if it is out of service for a long time; this will avoid leakage, heating or rupture.
- 03.Do not soak it in water or let it come into contact with any liquid; otherwise it may cause leakage, heating or rupture.
- 04.Be sure to stop using it immediately in case of any exception (e.g. discoloration or deformation), to avoid leakage, heating or rupture.
- 05.Always use tape to insulate the battery's electrode when recycling or disposing of it.

⚠ Warning

- 01.When skin or clothing is exposed to the battery electrolyte, immediately wash with clean water to avoid inflammation of skin, etc.
- 02.Do not use the rechargeable battery on other devices. This battery is only suitable for Tesvor smart sweeping robots.
- 03.If the battery's outer box is found to be deformed and expanded, or leakage of electrolytes is found, do not charge or continue to use to avoid danger.
- 04.Do not throw or inflict a strong impact on the battery; doing so may cause leakage, heating or rupture.
- 05.Do not disassemble the battery pack; doing so may cause battery rupture and electrolyte outflow, leading to fire, explosion and other dangers.
- 06.This appliance can be used by children aged from 8 years and above and persons with reduced physical, sensory or mental capabilities or lack of experience and knowledge if they have been given supervision or instruction concerning use of the appliance in a safe way and understand the hazards involved.
- 07.Children shall not play with the appliance.
- 08.Cleaning and user maintenance shall not be made by children without supervision.
- 09.This appliance contains batteries that are only replaceable by skilled persons.

5.4 Maintenance of Other Components

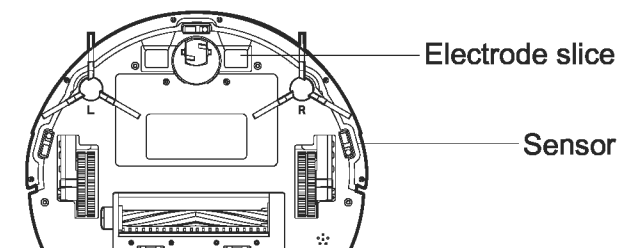

Use the cleaning tools or a dry soft cloth to periodically clean the charging plate of robot chassis and the sensor window.

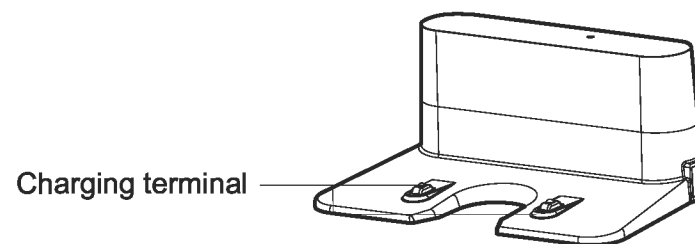

Use a cleaning tool or soft cloth to clean the charging base terminal.

5.3 Maintenance of Rolling Brush Components

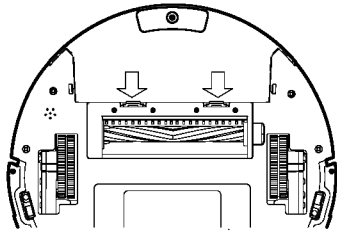

Open the rolling brush components.

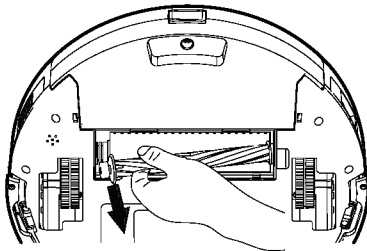

Remove the rolling brush shaft and clean off any debris and hair.

10. **WARNING:** For the purposes of recharging the battery, only use the detachable supply unit provided with this appliance.

11. The power supply must be removed from the socket-outlet before cleaning or maintaining the appliance.

12. The battery must be removed from the appliance before it is scrapped.

13. The appliance must be disconnected from the supply mains when removing the battery.

14. The battery should be safely disposed off.

15. How to remove the battery :

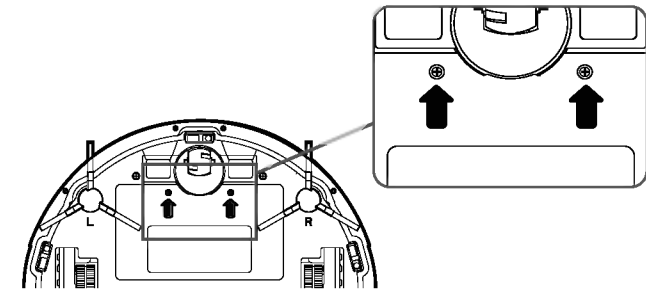

- ① Take out two screws on the battery cover with a screw driver.
- ② Take out the battery cover.
- ③ Take out the battery and unplug the electric wires to remove the battery.

☆ In addition, you can get our instructions by emailing to service @ tesvor.com.

3.1 Names of Parts

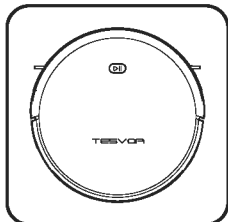

Main Body

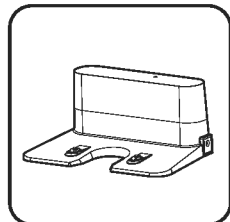

Charging Base

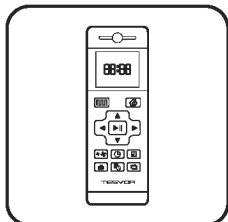

Remote Control

(2 * AAA Batteries REQUIRED
but NOT INCLUDED)

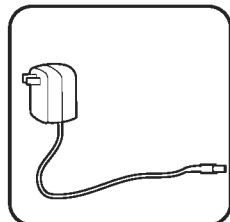

Power Adapter

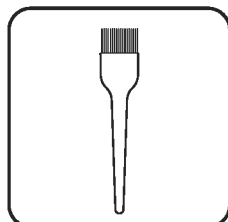

Cleaning Tool

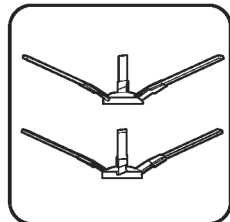

Side Brushes

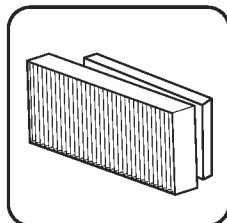

High-effective Filter/Sponge

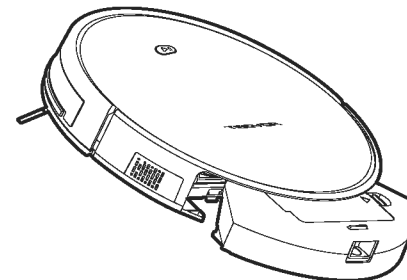

Cover the dust box and attach it to the main body.

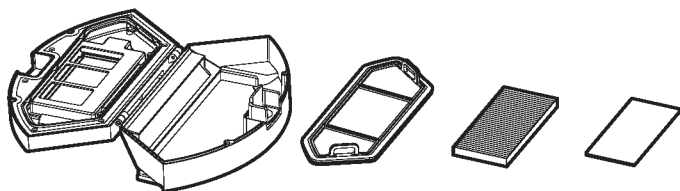

- ① Dry the dust box and filter components. Keep them dry to ensure a longer service life.
- ② After the pre-filter is used for 15-30 days, it should be washed once.
- ③ The maximum service life of the high-efficient filter is 3 months.

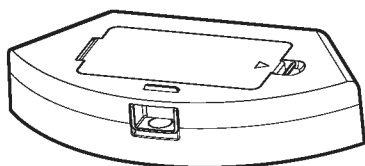

- ① Reinstall the pre-filter and high-efficient filter in the dust box.
- ② Before installing the filter, make sure that the high-efficient filter and the pre-filter are dry.
- ③ Do not expose the high-efficient filter and the pre-filter to sunlight.

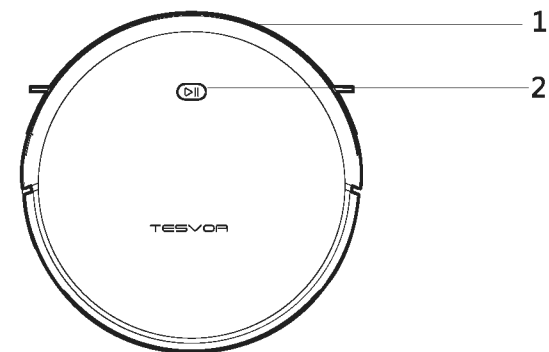

Main Body

1. Bumper 2. Control button

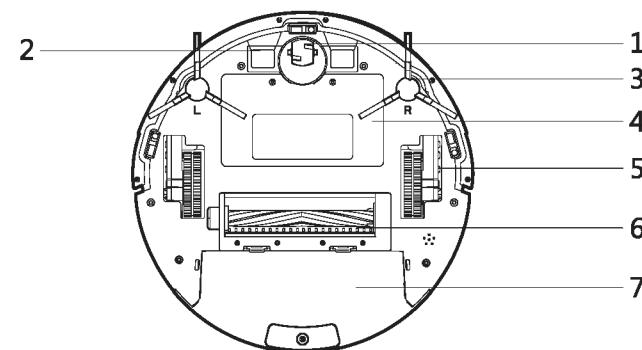

Main Body

1. Universal wheel 2. Charging shrapnel 3. Side brush 4. Battery cover

5. Cincture 6. Rolling brush components 7. Dust box

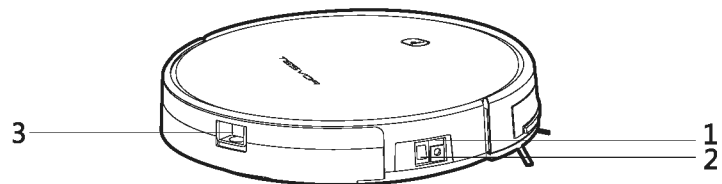

Main Body

1. DC power jack 2. Power switch 3. Dust box release button

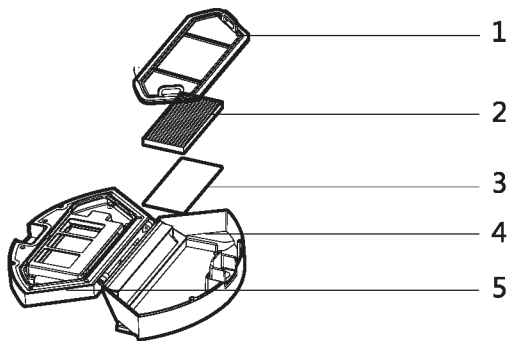

Dust Box

1. Pre-filter 2. High-effective filter 3. Filter sponge 4. Dust box

5. Dust box cover

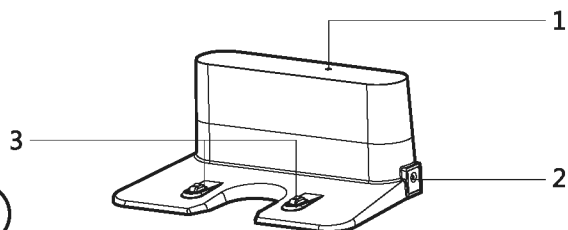

Charging base

1. Charging indicator 2. DC power jack 3. Charging terminal

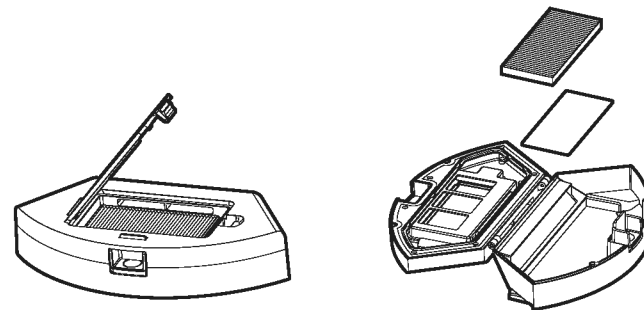

Open the high-efficient net cover, and remove the high-efficient filter and filter sponge. It is not recommended to wash the high-efficient filter with water. Please pat off the debris carefully.

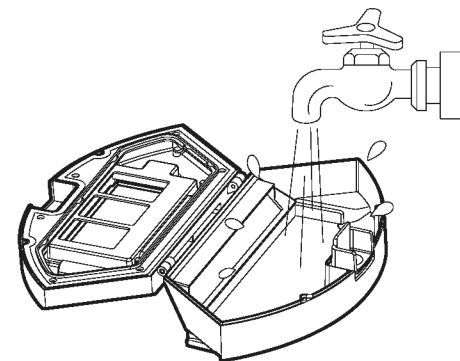

Wash the dust box and pre-filter.

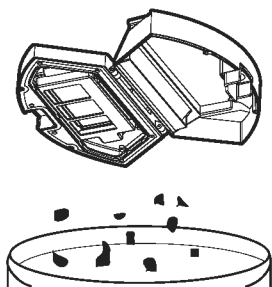

Dump all debris from the dust box into the garbage.

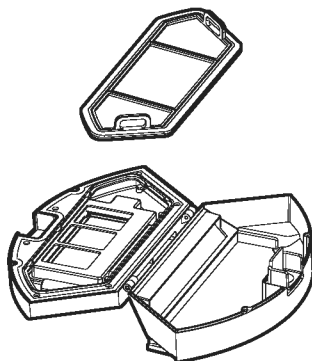

Remove the pre-filter.

3.2 Product Specifications

Structure Type

Diameter of main body	330 mm
Thickness of main body	75 mm
Net weight of main body	3.0 kg

Electronic Type

Voltage	14.4 V
Battery capacity	2500 mAh
Main body button type	LED button

Accessory Type

Dust box capacity	600 ml
Cleaning modes	Plan Cleaning / Edge Cleaning

Process Parameters

Charging Type	Manual/Automatic
Operating duration	<= 100 min
Charging duration	240 – 360 min

The ambient temperature range for storage of the product is 0-40 degrees Celsius

3.3 Product Characteristics

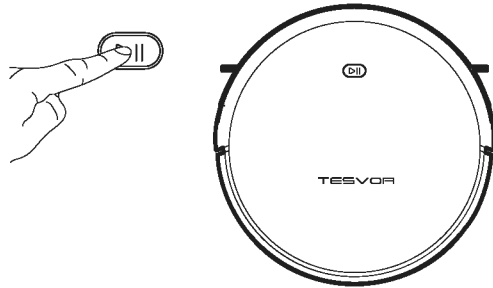

Humanized Design

It is simple to operate. You can control the robot only by pressing the Control button! Follow the prompt tone to operate the robot!

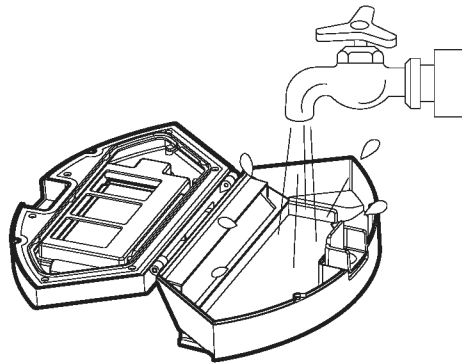

Dust box can be washed with water

The dust box and the pre-filter can be directly flushed with water without too much labor, which can avoid secondary pollution caused by dust flying!

5.1 Side Brush Cleaning and Replacement

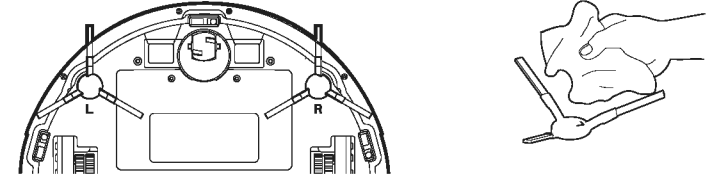

Check the side brush's condition frequently to see if it has been damaged or entangled with other objects. Clean the side brush with a cleaning tool or cloth. When the side brush is damaged and cannot be used, please replace it as soon as possible. L and R correspond to each other.

5.2 Cleaning of Dust Box and Filter

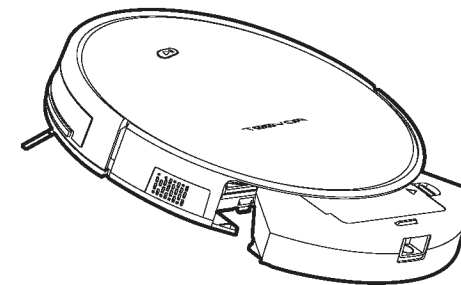

Press the release button on the dust box to remove it.

Cleaning Modes

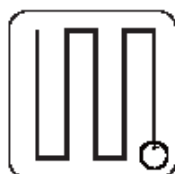

Plan Cleaning

The robot will perform the smart Plan Cleaning according to the room environment.

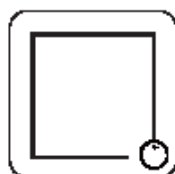

Edge Cleaning

The robot will clean along the longest edge of the room.

4.1 Remote Control Instructions

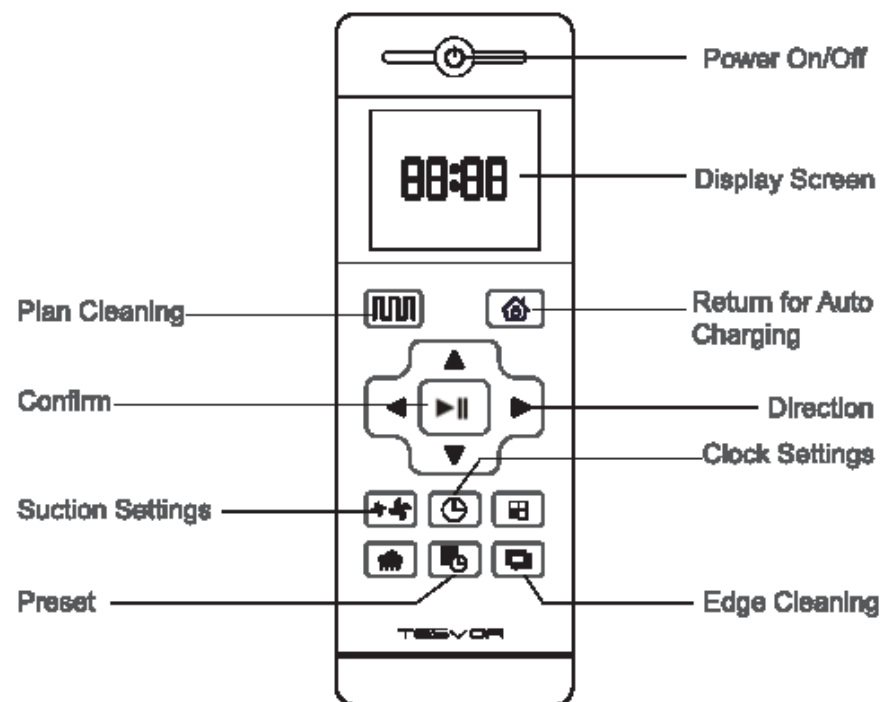

When the robot is in the vicinity of the charging base and the virtual protection wall, it may not be able to distinguish the instructions issued by the remote control. If you do not use the remote control for a long time, please remove the battery.

Plan Cleaning button

At any cleaning mode, press this button to enter the Plan Cleaning mode.

Auto Charging

Press this button to enter the auto charging mode, and the screen displays of remote control.

▲ Forward /+

At the standby mode, press this button to continue moving forwards, and release it to return to the standby mode.

At the Preset mode or the Time Settings mode, press this button to increase the number.

▼ Backwards /-

At the standby mode, press this button to continue moving backwards, and release it to return to the standby mode.

At the Preset mode or the Time Settings mode, press this button to decrease the number.

◀ Left Arrow

At the standby mode, press this button to continue turning left, and release it to return to the standby mode.

At the Preset mode or the Time Settings mode, press this button to switch from minute to hour.

▶ Right Arrow

At the standby mode, press this button to continue turning right, and release it to return to the standby mode.

At the Preset mode or the Time Settings mode, press this button to switch from hour to minute.

▶| Confirm button

During operation, press this button to stop the robot, and it is still working at the pause.

At the Preset or Clock Settings mode, press this button to save the settings.

↕ Suction Settings button

At any cleaning mode, press this button to adjust the suction power.

🕒 Clock Settings button

Press this button to enter the Clock Setting mode and press the OK button to exit.

🕒 Preset button

At the standby mode, press this button to enter the presetting mode, and the display flashes icon 🕒.

At the preset mode, press this button to save the data and exit the preset mode, and the display will always display the icon 🕒.

At the preset mode, press the preset button for 3S to cancel the preset function, and the displayed icon 🕒 will disappear.

🏠 Edge Cleaning button

Press this button to enter the Edge Cleaning mode.



Display preset time



Display clock time



- ☆ Once the power switch is turned off, all pre-settings will be cancelled.
- ☆ Once the presetting is in effect, the robot will start working at the appointed time every day.

Press the "Preset" button to set the robot's scheduled cleaning time. (e.g. Set the robot to 6:30 am at the standby mode, the machine will start cleaning at 6:30 am every day).



- ☆ At the preset cleaning mode, all operations will be prompted to confirm.

- ① Press the Preset button so that the robot enters the Preset mode and set the preset time on the remote control.
- ② After setting is completed, press the Power on/off button or Preset button to complete the setting of Preset. During the setting, you need to face the robot.
- ③ If you need to cancel the presetting, you can press the Preset button for 3 seconds.



Charging Instructions

01. The battery should be repaired and replaced by the aftersales department.
02. For the very first operation, please let the robot run out of power.
03. When the robot is charged, the Control button will flash a green lamp in a circular manner.
04. If the robot is out of service for a long time, please turn off the power switch.
05. Please charge the robot as soon as possible after the battery is used up.
06. The product can only use the power adapter and charger provided by the factory.
07. Please charge the robot for 12 hours for the first time of operation. When the charge is done, the Control button light turns off.

Preset cleaning

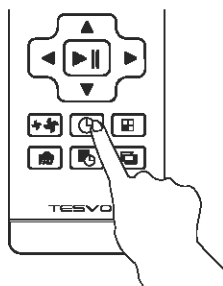

You can set the robot by pressing the Time Settings button on the remote control to the current U.S. time, and press OK button.

4.2 Operating Instructions

Placement of the Charging Base

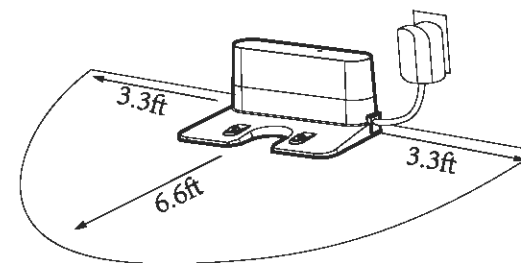

Place the seat flat against the wall. Do not place any objects within 3.3 ft to the left / right and 6.6 ft to the front, and do not place any mirrors or other reflective objects within this distance.

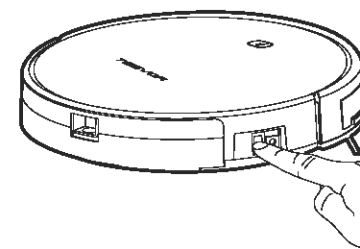

Switch on the robot, which makes the Control button green, and enter the Select mode. If the robot is not active within 3 minutes, the robot will enter Sleep mode.

Charging Modes

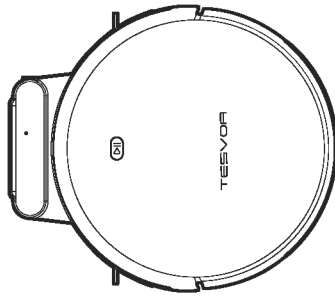

At any mode, select the Return for Auto Charging button on the remote control to make the robot return for charging.

Auto Charging

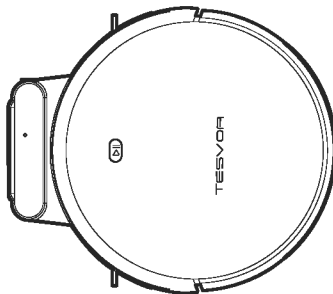

When cleaning is completed or the battery is too low, the robot will automatically start finding the charging base to charge itself. Please keep the charging base energized, otherwise the machine will not be able to find the charging base.

Switching Modes

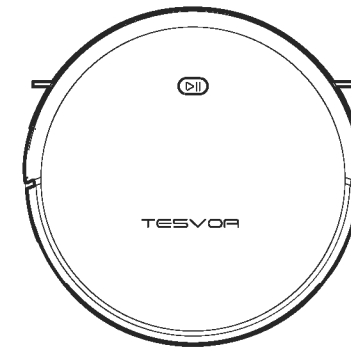

Startup

01. Make sure the power switch on the side of the robot is turned on.
02. Press the Control button or the Cleaning mode on the remote control to start the robot.

Pause

The pause function is to switch the robot from the operating mode to the selected mode, and the robot can be paused by the following operations:

01. Press the Control button on the robot to pause the robot.
02. Press the power on/off button on the remote control to pause the robot.

Sleep

Sleep mode means that the robot is stopped and the indicator light is off. If the robot is not active within 3 minutes, the robot will enter Sleep mode automatically.

Note: If the robot is out of service for a long time, please turn off the power switch.