











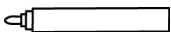
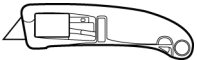

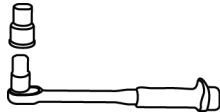

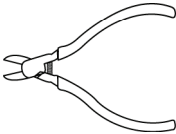
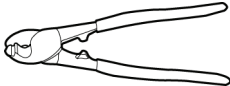
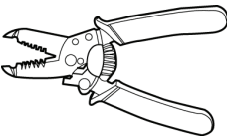
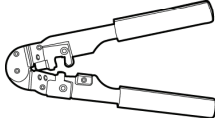
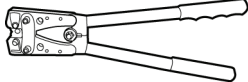
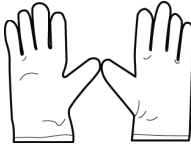
BTS3911B
V100R010C10
Installation Guide

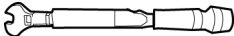
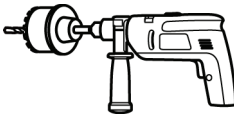
Issue: Draft A
Date: 2015-01-20

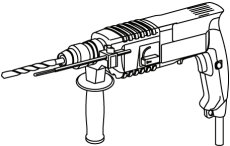
HUAWEI TECHNOLOGIES CO., LTD.

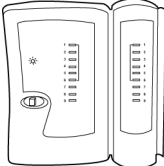

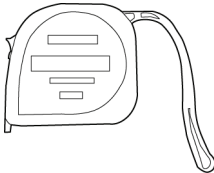
Installation Tools

				
Marker	Utility knife	Rubber mallet	Socket wrench (M6)	Level
				
Diagonal pliers	Cable cutter	Wire stripper	RJ11 crimping tool	Power cable crimping tool
				
ESD gloves	Protective gloves	Torque wrench (bore size: 10 mm)	crown saw (Ø60 bore)	Phillips torque screwdriver (M4 to M6)
				
Hammer drill (Ø6, Ø8 or Ø12 bore)	Ladder	Vacuum cleaner	Network cable tester	Multimeter
		-	-	-
Measuring tape	Torque wrench for SMA connectors	-	-	-

Product Introduction

BTS3911B

The BTS3911B uses internal antennas.

Appearance

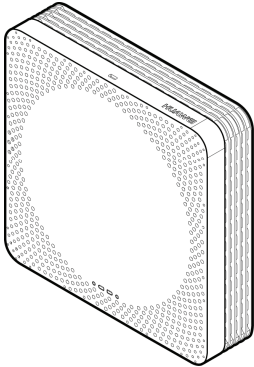

Dimensions

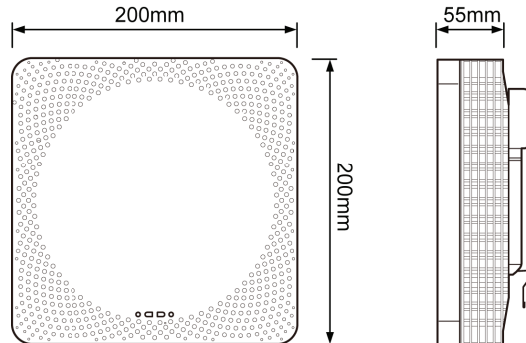

Ports

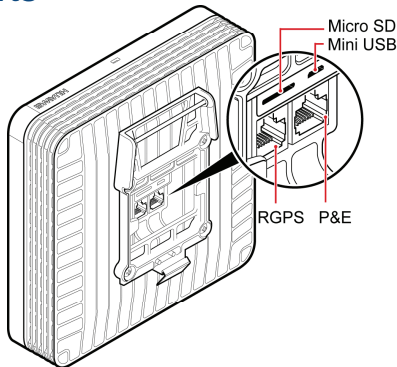

Port Description

Port	Description
Micro SD	Anchor slot for the Micro SD card used for deployment
Mini USB	Port for clock output
RGPS	Port for clock synchronization
P&E	Port for transmission and power supply

PSE

Appearance and Dimensions

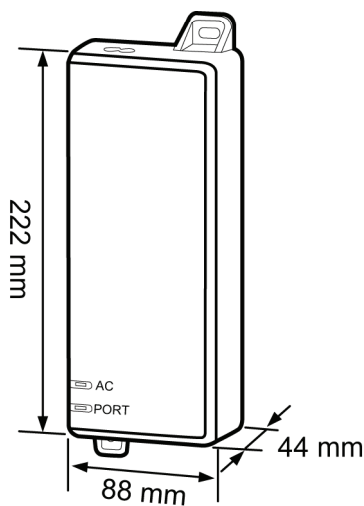

Port Description

Port	Description
-	Power port that supplies power to the PSE
DATA	Data input port that connects to transmission equipment of an operator
PoE	PoE output port that connects to the BTS3911B

Installation Scenarios

Wall-mounted Installation

- The wall must have a bearing capacity of at least four times the weight of the BTS3911B.
- The screws must be torqued to 1.5 N·m and work properly without causing cracks on the wall.
- The thickness of the wall must be less than the bolt length (45 mm) to allow for installation through an existing plate.
- If the wall is too thick, use a customer-provided installation plate.

- By drilling holes

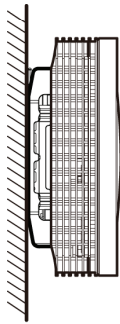

- Through an existing plate

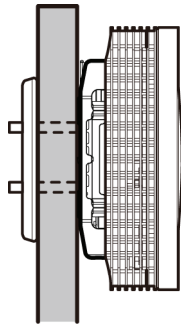

- By using a customer-provided installation plate

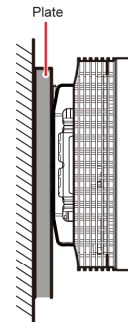

Ceiling-mounted Installation

- The ceiling (such as concrete ceiling) must have a bearing capacity of at least four times the weight of the BTS3911B.
- The screws must be torqued to 1.5 N·m and work properly without causing cracks on the wall.
- The thickness of the ceiling must be less than the bolt length (45 mm) to allow for installation through an existing plate.

- By drilling holes

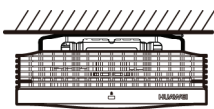

- Through an existing plate

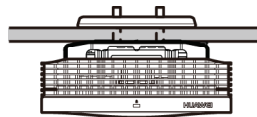

- By using a keel

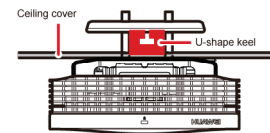

Keel-mounted Installation

The BTS3911B can be installed on a U-shaped, T-shaped, H-shaped, or other shaped keel, depending on site requirements. The following figure illustrates keel-mounted installation on a ceiling.

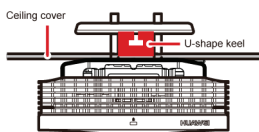

Clearance Requirements

- For a BTS3911B

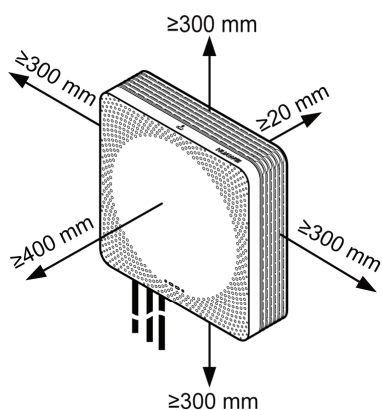

- For a PSE

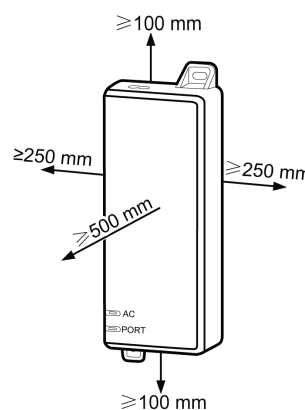

Installation Environment Requirements

Operating Environment Requirements

Specifications	Requirements	Remarks
Operating temperature	-5 °C to +40°C	-
Relative humidity	5% RH to 95% RH	-
Altitude	-60 m to +1800 m	The BTS3911B works properly under the condition.
	1800 m to 4000 m	From the altitude of 1,800 m, the maximum operating temperature drops by 1°C each time the altitude increases by 220 m.

Other Requirements

- The BTS3911B cannot be installed near air conditioner outlet or near other heat-generating appliances.
- The BTS3911B cannot be installed near a strong heat source of any kind.
- The BTS3911B cannot be installed near places where water may leak or drip, such as near outdoor air conditioner units, water pipes, pipelines, and roofs with water leaks or dripping runoff.
- The installation must be protected against rain. No window exists at either side of the wall where the BTS3911B is installed.
- The installation position must be far away from high voltage, highly corrosive devices, flammable or explosive substances, and electromagnetic interference.
- The BTS3911B must be installed in a dry, well-ventilated, and dustproof place.
- If the BTS3911B is installed in parking areas or basements, the installation position must be well ventilated.

Installation Process

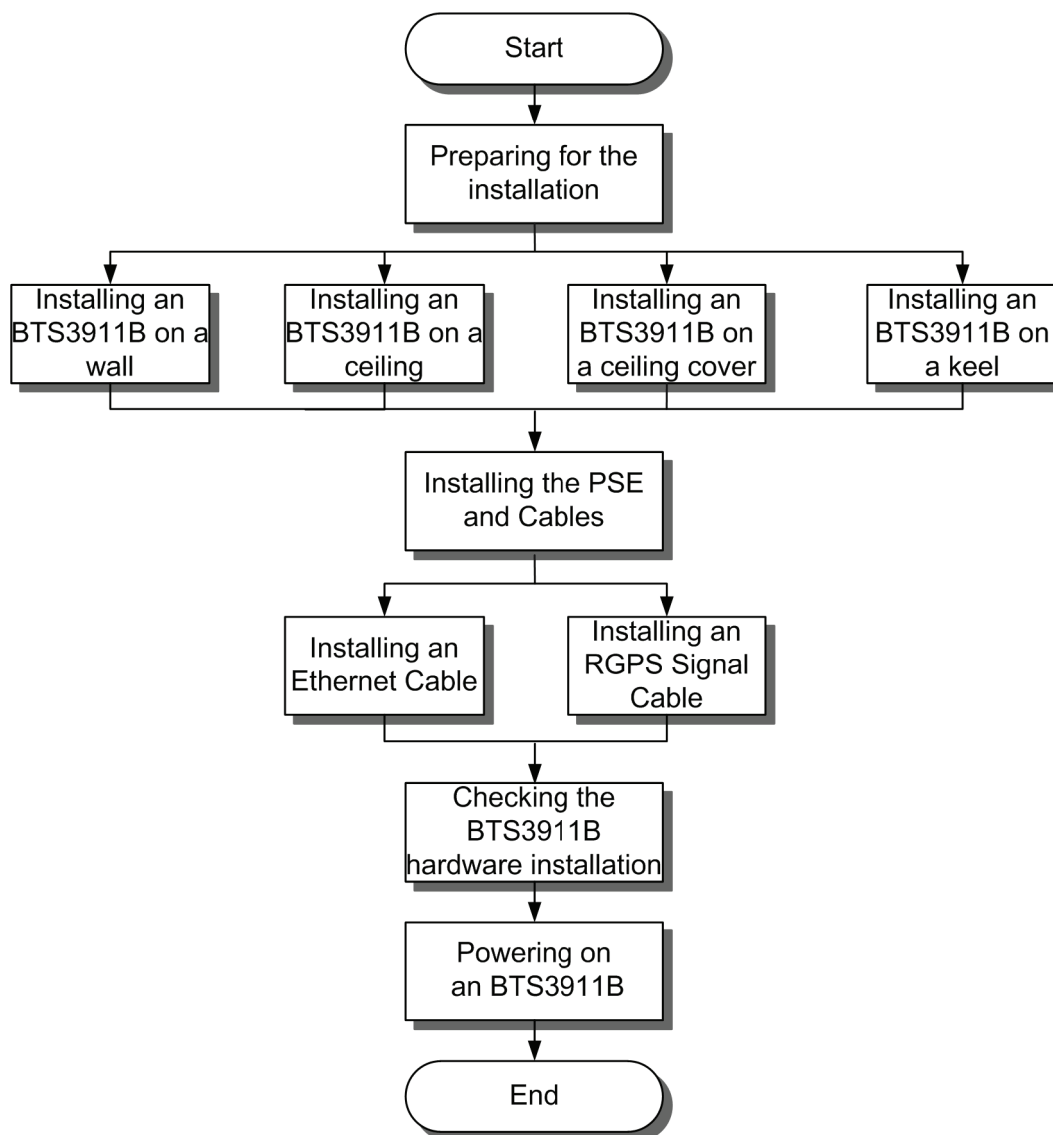

Obtaining the ESN

Before installation, record the ESN, which will be used during commissioning. Before removing the backup ESN label, photograph it.

- 1 Remove the backup ESN label from the BTS3911B packing box.
- 2 Record the ESN by following instructions provided in Appendix 3 and report the ESN to the BTS3911B commissioning personnel. Keep the backup ESN label secure.

Installing a BTS3911B

BTS3911B can be installed on a wall or ceiling directly or by using a plate or keel.

Mounting Kits

● Wall- or ceiling-mounted installation

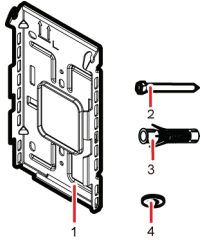

- (1) Mounting bracket
- (2) Screws (M3.5X35)
- (3) Plastic expansion sleeve
- (4) Flat washer

● Installation on a plate or keel

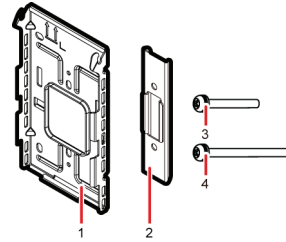

- (1) Mounting bracket
- (2) V clamp
- (3) Bolt (M4X35)
- (4) Bolt (M4X36)

Installing a BTS3911B on a Wall

1 Mark anchor points

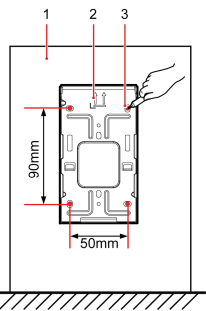

- (1) Wall
- (2) Mounting bracket
- (3) Anchor points

2 Drill holes and install plastic expansion sleeves

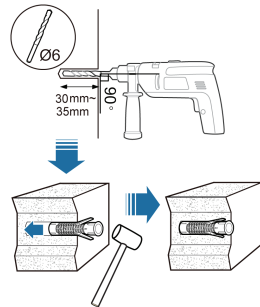

3 Install mounting kits

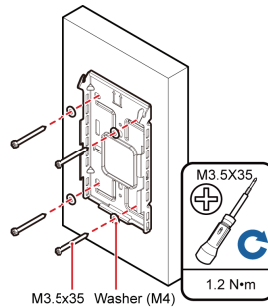

4 Install the BTS3911B on the wall

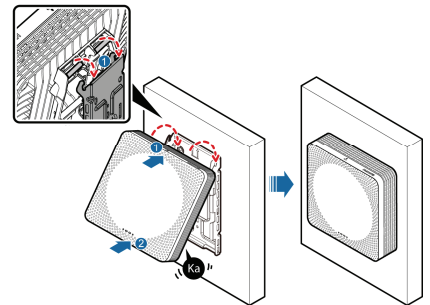

Installing a BTS3911B on a Ceiling

1 Mark anchor points

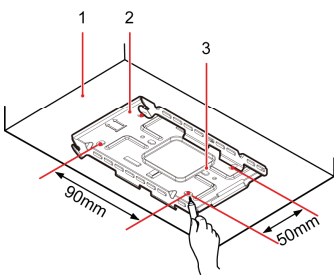

- (1) Wall
- (2) Mounting bracket
- (3) Anchor points

2 Drill holes and install plastic expansion sleeves

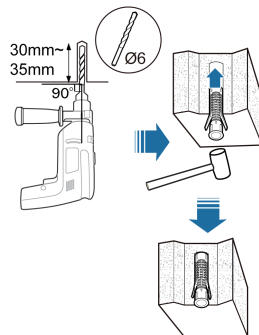

3 Install mounting kits

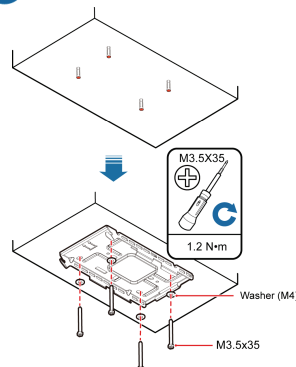

4 Install the BTS3911B on the ceiling

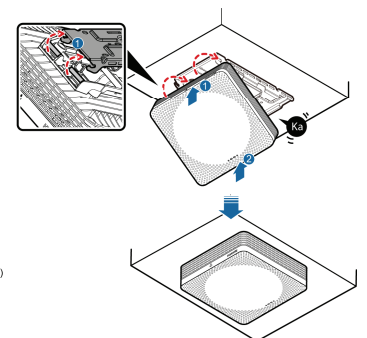

Installing a BTS3911B on a Plate

On a ceiling plate (for example, daughter board on the ceiling) capable of being screwed

1 Mark anchor points

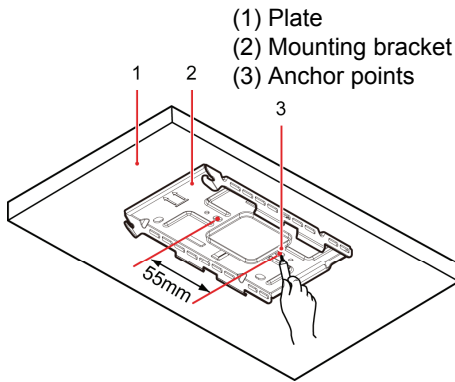

3 Install mounting kits

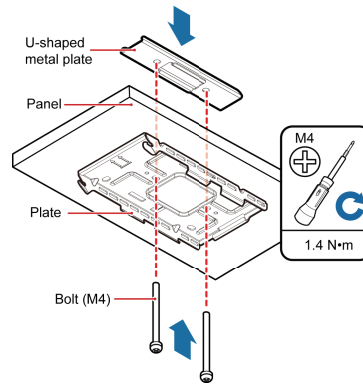

4 Install the BTS3911B on the ceiling plate

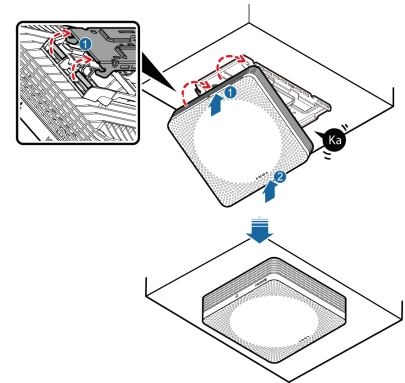

2 Use a hammer drill with $\Phi 6$ bore to drill holes

On a ceiling plate (for example, gypsum board) incapable of being screwed

1 Use a crown saw to drill a hole (diameter: 60-65 mm)

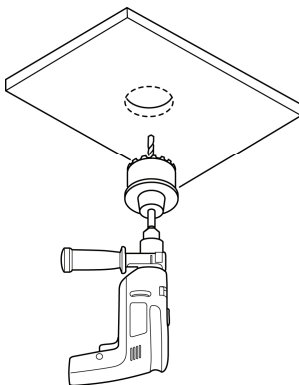

2 Partially install mounting kits

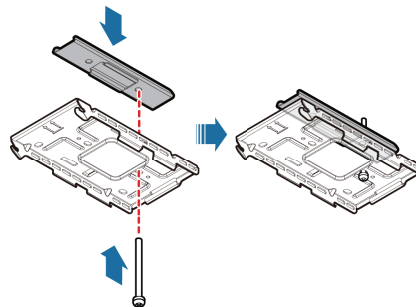

3 Lead the U-shaped metal plate through the hole on the ceiling

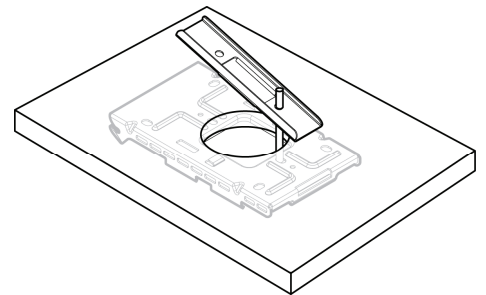

4 Secure mounting kits to the ceiling plate

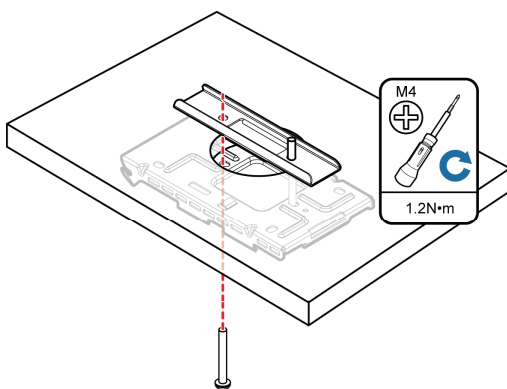

5 Install the BTS3911B on the ceiling plate

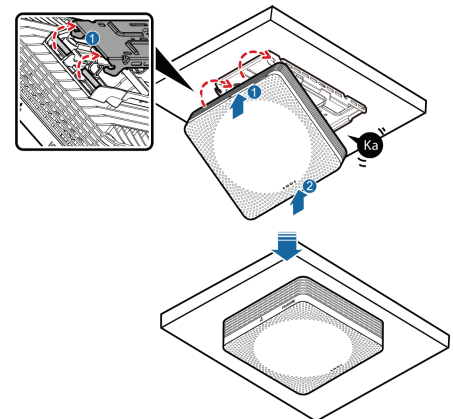

Installing a BTS3911B on a Keel

1 Mark anchor points

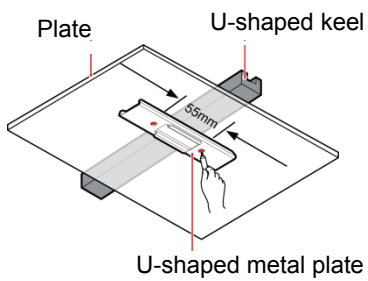

2 Use a hammer drill with $\Phi 12$ bore to drill holes

3 Install mounting kits

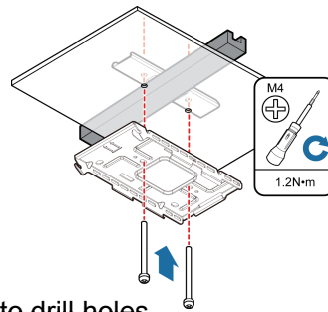

4 Install the BTS3911B on the plate

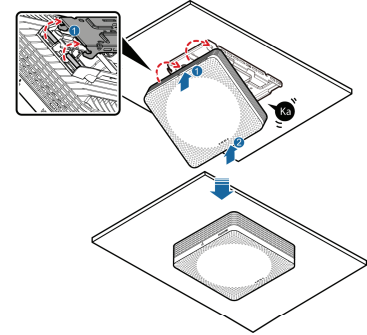

Installing the PSE and Its Cables

The PSE can be installed only on an indoor wall.

Installing the PSE

1 Place the PSE against the wall, level it in the installation position, and mark anchor points

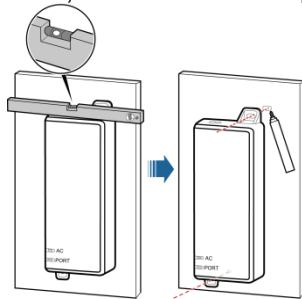

2 Drill holes and install expansion bolts

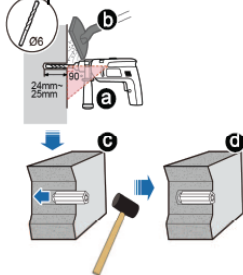

3 Install the PSE

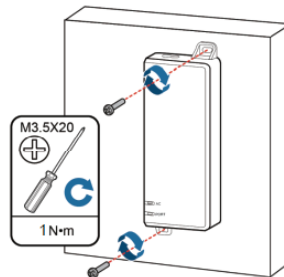

Installing Cables

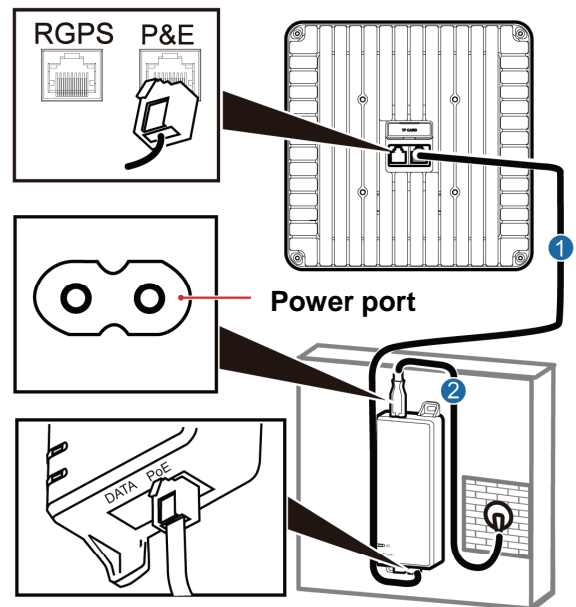

- (1) Ethernet cable
- (2) PSE power cable

Installing the BTS3911B Cables

- Installing an Ethernet cable
- Installing an RGPS signal cable

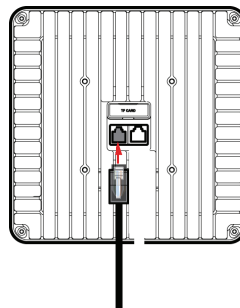
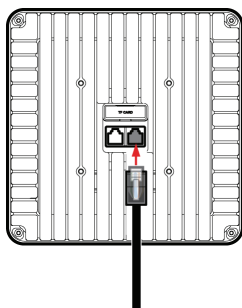

Installation Check

SN	Check Item
1	The installation position conforms to the engineering design and meets clearance requirements.
2	The BTS3911B is securely installed.
3	In wall-mounted scenarios, the holes on the mounting bracket are well aligned with the holes of the expansion bolt assemblies. In addition, the mounting bracket is secured on the wall evenly and tightly.
4	The surface of the BTS3911B is neat and clean. The external paint is intact. The labels, tags, and nameplates are correct, legible, and complete.
5	In the wall-mounted scenario, the holes of the mounting bracket are well aligned with the holes of the expansion bolt assemblies. In addition, the mounting bracket is secured on the wall evenly and steadily.
6	None of power cables or signal cables is short-circuited or reverse connected. All cables are not damaged or broken.
7	The power cables and PGND cables are bound and routed separately from other cables.
8	The connectors of the signal cables are intact and securely connected. The signal cables are intact.
9	Labels are correct, legible, and complete at both ends of each cable.

Power-on Check

After you unpack a BTS3911B, you must power it on within 24 hours. If you power off the BTS3911B for maintenance, you must restore power to the BTS3911B within 24 hours.

Check Process

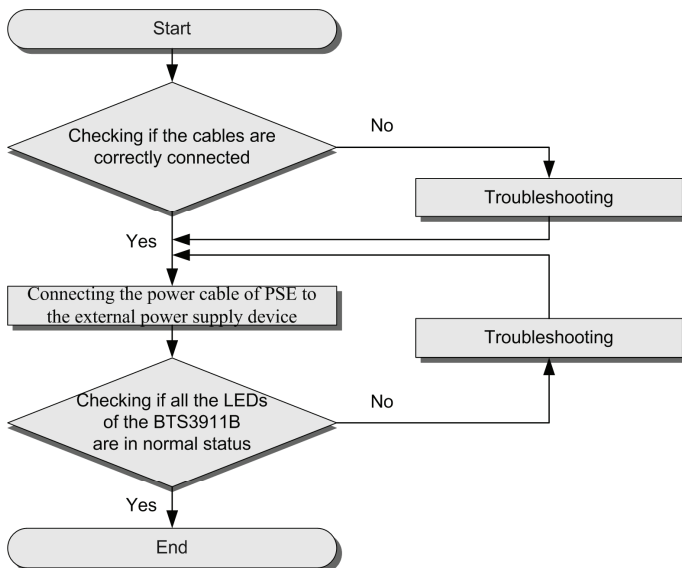

Checking the Indicator Status

If...		Then...
3GPP	blinks white (on for 1s and off for 1s)	The BTS3911B is running correctly.
CPRI	is steady white	
WIFI	blinks white (on for 1s and off for 1s)	
LINK	is steady white	

NOTE

- During the BTS3911B startup, there is no need to observe the indicator status.
- During a start, the BTS3911B reads and writes the flash and therefore the indicators blinking quickly may blink irregularly for 1-2 seconds, which does not affect services.

Appendix 3: ESN collection template

The ESN collection template is used to record the installation position and ESN of the site at the initial installation stage to facilitate subsequent commissioning and maintenance.

No.	Site Number	Site Name	ESN	Location Information
<i>Sample</i>	<i>xx</i>	<i>BTS3911B</i>		<i>xx floor, xx building, xx mansion</i>

Note: This template is essential to the engineering stage and subsequent maintenance, especially when multiple devices are installed within a short distance. This is because the template defines the radio network to access. Please carefully maintain this template.

HUAWEI TECHNOLOGIES CO., LTD.

Huawei Industrial Base Bantian Longgang

Shenzhen 518129

People's Republic of China

www.huawei.com

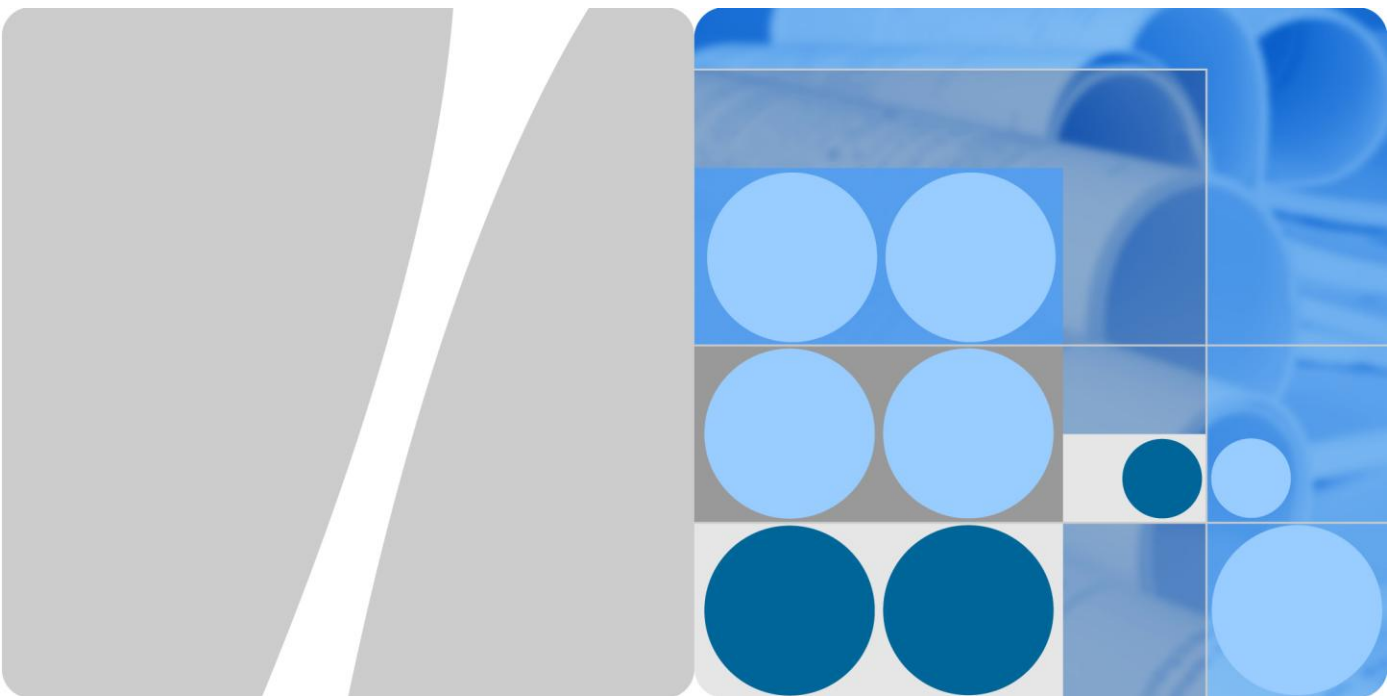

Regulatory Compliance Statement

BTS3911B

CE 06820

Issue: 01

Date:2015-7-6

Copyright © Huawei Technologies Co., Ltd. 2010. All rights reserved.

No part of this document may be reproduced or transmitted in any form or by any means without prior written consent of Huawei Technologies Co., Ltd.

Trademarks and Permissions



HUAWEI and other Huawei trademarks are trademarks of Huawei Technologies Co., Ltd.

All other trademarks and trade names mentioned in this document are the property of their respective holders.

Notice

The purchased products, services and features are stipulated by the contract made between Huawei and the customer. All or part of the products, services and features described in this document may not be within the purchase scope or the usage scope. Unless otherwise specified in the contract, all statements, information, and recommendations in this document are provided "AS IS" without warranties, guarantees or representations of any kind, either express or implied.

The information in this document is subject to change without notice. Every effort has been made in the preparation of this document to ensure accuracy of the contents, but all statements, information, and recommendations in this document do not constitute the warranty of any kind, express or implied.

Huawei Technologies Co., Ltd.

Address: Huawei Industrial Base
Bantian, Longgang
Shenzhen 518129
People's Republic of China

Website: <http://www.huawei.com>

Email: support@huawei.com

1 Regulatory Compliance Statement

About This Chapter

1.1 Declaration of Conformity to European Directives

1.1 Declaration of Conformity to European Directives

Figure 1-1 Declaration of Conformity to European Directives



TEL: 0755-28780808
FAX: 0755-89662618
http://www.huawei.com

Doc NO.: CE-01820149

Declaration of Conformity

For EU Directives and Regulations

For the following equipment

Product : Pico BTS
Model/Trademark : BTS3911B / HUAWEI
Manufacturer's Name : Huawei Technologies Co., Ltd.
Manufacturer's Address : Administration Building, Headquarters of
Huawei Technologies Co., Ltd., Bantian,
Longgang District, Shenzhen, 518129, P.R.C

is herewith confirmed to comply with the requirements which are set out in 1999/5/EC(R&TTE Directive), 2002/95/EC & 2011/65/EU (RoHS Directive), 2002/96/EC&2012/19/EU (WEEE Directive) and 2006/1907/EC(REACH Regulation). For the evaluation of the compliance with these Directives and Regulations, the following standards/requirements were applied:

Safety	EN 60950-1:2006+A11:2009+A1:2010+A12:2011+A2:2013 IEC/EN 60215(1989) ed3 +A1:1992+A2:1994
EMC	ETSI EN 301 489-1 V1.9.2 EN 55022:2010 CISPR 22:2008 ETSI EN 301 489-17 V2.2.1 EN 55024:2010 CISPR 24:2010 ETSI EN 301 489-23 V1.5.1
Radio & Health	ETSI EN 301 908-1 V6.2.1 ETSI EN 301 908-14 V6.2.1 ETSI EN 300 328 V1.8.1 ETSI EN 301 893 V1.7.1 Council Recommendation 1999/519/EC EN 50385:2002 EN 62311:2008 IEC 62232:2011
RoHS	2002/95/EC, 2011/65/EU, EN 50581: 2012
REACH	EC NO. 1907/2006
WEEE	2002/96/EC, 2012/19/EU

CE Marking Date: Jun 16, 2015

Responsible for making this declaration is the:

Manufacturer Authorised representative established within the EU

Person responsible for making this declaration

Name/Title: *Zhang Xingwei* Regulation Compliance Manager

Print Name: Zhang Xingwei

Place/Date: Shenzhen, China Jun 16, 2015

2 Regulatory Compliance Information

About This Chapter

- 2.1 Regulatory Compliance Standards
- 2.2 European Regulatory Compliance
- 2.3 U.S.A Regulatory Compliance
- 2.4 Canada Regulatory Compliance
- 2.5 Japanese Regulatory Compliance
- 2.6 CISPR 22 Compliance
- 2.7 China RoHS hazardous substance table
- 2.8 India RoHS hazardous substance table
- 2.9 Other Markets

2.1 Regulatory Compliance Standards

Product complies with the standards listed in [Table 2-1](#).

Table 2-1 Regulatory compliance standards

Discipline	Standards
EMC	<ul style="list-style-type: none"> • CISPR22 Class B • CISPR24 • EN55022 Class B • EN50024 • ETSI EN 301 489 Class B • CFR 47 FCC Part 15 Class B • FCC Part 2 • FCC Part 22 • FCC Part 24 • ICES 003 Class B/Class A • AS/NZS CISPR22 Class B • GB9254 Class B • VCCI Class B • CNS 13438 Class B • IEC61000-6-1 • IEC61000-6-3 • EN61000-6-1 • EN61000-6-3
Safety	<ul style="list-style-type: none"> • IEC 60950-1 • IEC60950-22 • IEC/EN60215 • IEC/EN41003 • EN 60950-1 • UL 60950-1 • CSA C22.2 No 60950-1 • AS/NZS 60950.1 • BS EN 60950-1 • IS 13252 • GB4943
Laser safety	<ul style="list-style-type: none"> • FDA rules, 21 CFR 1040.10 and 1040.11 • IEC60825-1, IEC60825-2, EN60825-1, EN60825-2 • GB7247

Discipline	Standards
RF	<ul style="list-style-type: none">• ETSI EN 301 908• ETSI EN 300 328• ETSI EN 301 893• FCC Part 2• FCC Part 24• FCC Part 27• RSS-133• RSS-139
Health	<ul style="list-style-type: none">• ICNIRP Guideline• 1999-519-EC• EN 50385• OET Bulletin 65• FCC Part 1• IEEE Std C95.1• EN 60215• RSS-102
Environmental protection	<ul style="list-style-type: none">• 2011/65/EU (RoHS)• EC NO. 1907/2006 (REACH)• 2002/96/EC (WEEE)
Grounding	<ul style="list-style-type: none">• ITU-T K.27• ETSI EN 300 253

Discipline	Standards
<p>NOTE</p> <p>EMC: electromagnetic compatibility</p> <p>NEBS: Network Equipment Build Standard</p> <p>RF: radio frequency</p> <p>CISPR: International Special Committee on Radio Interference</p> <p>EN: European Standard</p> <p>ETSI: European Telecommunications Standards Institute</p> <p>CFR: Code of Federal Regulations</p> <p>FCC: Federal Communication Commission</p> <p>IEC: International Electrotechnical Commission</p> <p>AS/NZS: Australian/New Zealand Standard</p> <p>VCCI: Voluntary Control Council for Interference</p> <p>CNS: Chinese National Standard</p> <p>UL: Underwriters Laboratories</p> <p>CSA: Canadian Standards Association</p> <p>BS: British Standard</p> <p>IS: Indian Standard</p> <p>GR: General Requirement</p> <p>FDA: Food and Drug Administration</p> <p>BTS: Base Transceiver Station</p> <p>GSM: Global System for Mobile communications</p> <p>WLAN: wireless local area network</p> <p>ICNIRP: International Commission on Non-Ionizing Radiation Protection</p> <p>OET: Office of Engineering Technology</p> <p>IEEE: Institute of Electrical and Electronics Engineers</p> <p>RoHS: restriction of the use of certain hazardous substances</p>	

2.2 European Regulatory Compliance

Product complies with the following European directives and regulations.

- 2004/108/EC (EMC)
- 2006/95/EC (low voltage)
- 1999/5/EC (R&TTE)
- 2011/65/EU (RoHS)
- EC NO. 1907/2006 (REACH)
- 2002/96/EC (WEEE)

Product complies with Directive 2002/95/EC, 2011/65/EU and other similar regulations from the countries outside the European Union, on the RoHS in electrical and electronic equipment. The device does not contain lead, mercury, cadmium, and hexavalent chromium and brominated flame retardants (Polybrominated Biphenyls (PBB) or Polybrominated Diphenyl Ethers (PBDE)) except for those exempted applications allowed by RoHS directive for technical reasons.

Product complies with Regulation EC NO. 1907/2006 (REACH) and other similar regulations from the countries outside the European Union. Huawei will notify to the European Chemical Agency (ECHA) or the customer when necessary and regulation requires.

Product complies with Directive 2002/96/EC on waste electrical and electronic equipment (WEEE). Huawei is responsible for recycling its end-of-life devices, and please contact Huawei local service center when recycling is required. Huawei strictly complies with the EU Waste Electrical and Electronic Equipment Directive (WEEE Directive) and electronic waste management regulations enacted by different countries worldwide. In addition, Huawei has established a system for recycling and reuse of electronic wastes, and it can provide service of dismantling and recycling for WEEE. By Huawei recycling system, the waste can be handled environmentally and the resource can be recycled and reused fully, which is also Huawei WEEE stratagem in the word. Most of the materials in product are recyclable, and our packaging is designed to be recycled and should be handled in accordance with your local recycling policies.

In accordance with Article 11(2) in Directive 2002/96/EC (WEEE), products were marked with the following symbol: a cross-out wheeled waste bin with a bar beneath as below:

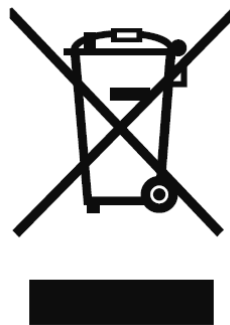

In order to avoid the possibility of exceeding the Europe radio frequency exposure limits, human proximity to the equipment shall not be less than 0.124 m

2.3 U.S.A Regulatory Compliance

2.3.1 Safety compliance Mark

2.3.2 FCC

2.3.1 Safety compliance Mark



CONFORMS TO
UL STD.60950-1
& UL STD.60950-22
CERTIFIED TO CAN/CSA STD.
C22.2 NO.60950-1-07
&CAN/CSA STD.C22.2 NO.
60950-22-07

2.3.2FCC

Product complies with Part 15 of the FCC Rules. Operation is subject to the following two conditions:

- This device does not cause harmful interference.
- This device must accept any interference received, including interference that may cause undesired operation.

If this device is modified without authorization from Huawei, the device may no longer comply with FCC requirements for Class B digital devices. In that a case, your right to use the device may be limited by FCC regulations. Moreover, you may be required to correct any interference to radio or television communications at your own expense.

This device has been tested and found to comply with the limits for a Class B digital device, pursuant to Part 15 of the FCC rules. These limits are designed to provide reasonable protection against harmful interference in a residential installation.

This device generates, uses and radiates radio frequency energy. If it is not installed and used in accordance with the instructions, it may cause harmful interference to radio communications.

However, there is no guarantee that interference will not occur in a particular installation. If this device does cause harmful interference to radio or television reception, which can be determined by turning the device off and on, the user may take one or more of the following measures:

- Reorient or relocate the receiving antenna.
- Reinforce the separation between the device and receiver.
- Connect the device into an outlet on a circuit different from that to which the receiver is connected.
- Consult the dealer or an experienced radio or TV technician for assistance.

In order to avoid the possibility of exceeding the 47CFR FCC Part 1 & OET Bulletin 65 radio frequency exposure limits, human proximity to the equipment shall not be less than 0.182 m

2.4 Canada Regulatory Compliance

2.4.1 RSS-Gen statement

This device complies with Industry Canada licence-exempt RSS standard(s).

Operation is subject to the following two conditions: (1) this device may not cause interference, and (2) this device must accept any interference, including interference that may cause undesired operation of the device.

Le présent appareil est conforme aux CNR d'Industrie Canada applicables aux appareils radio exempts de licence. L'exploitation est autorisée aux deux conditions suivantes : (1) l'appareil ne doit pas produire de brouillage, et (2) l'utilisateur de l'appareil doit accepter tout brouillage

radio électrique subi, même si le brouillage est susceptible d'en compromettre le fonctionnement.

2.4.2 RSS-102 statement

This device is designed and manufactured not to exceed the emission limits for exposure to radio frequency (RF) energy set by Industrial Canada and meets the requirements for radiation exposure limits set forth for an uncontrolled environment.

In order to avoid the possibility of exceeding the Industrial Canada radio frequency exposure limits, human proximity to the equipment shall not be less than 0.235 m

Cet appareil est conçu et fabriqué pour ne pas dépasser les limites d'émission pour l'exposition à la fréquence radio (RF) de l'énergie fixée par l'Industrie Canada et répond aux exigences en matière de limites d'exposition aux rayonnements définies pour un environnement non contrôlé.

Afin d'éviter la possibilité de dépasser les limites d'exposition aux fréquences radio industrielle du Canada, la proximité humaine pour l'appareil ne doit pas être inférieure à 0.235 m

The device is only for indoor use to reduce the potential for harmful interference to co-channel mobile satellite systems;

The worst-case tilt angle(s) necessary to remain compliant with the e.i.r.p. elevation mask requirement set forth in RSS-247 Section 6.2.2(3).

High-power radars are allocated as primary users (i.e. priority users) of the bands 5250-5350 MHz and 5650-5850 MHz and that these radars could cause interference and/or damage to LE-LAN devices.

2.5 Japanese Regulatory Compliance

2.5.1 VCCI

2.5.1 VCCI

Product complies with VCCI Class B by Information Technology Equipment (ITE).

The preceding translates as follows:

This is a Class B product based on the standard of the Voluntary Control Council for Interference by Information Technology Equipment (VCCI). If this product is used near a radio or television receiver in a domestic environment, it may cause radio interference. Install and use the equipment according to the instruction manual.

2.6 CISPR 22 Compliance

Product complies with CISPR 22 for Class B by the ITE.

2.7 China RoHS hazardous substance table

This products described in this guide complies with “the Administration on the Control of Pollution Caused by Electronic Information Products” which is also called China RoHS

部件名称	产品中有害物质或元素的名称及含量					
	镉	铅	汞	六价铬	多溴联苯	多溴联苯醚
Frame	○	×	○	○	○	○
Alloy Parts	○	×	○	○	○	○
Power Adapter	○	×	○	○	○	○
Metal Fittings	○	○	○	○	○	○
PCBA	○	×	○	○	○	○
Capacitor	○	×	○	○	○	○
Other electronics	○	×	○	○	○	○
Screen	○	○	○	○	○	○
Solder	○	×	○	○	○	○
Cable	×	×	○	○	○	○
Plastic and Polymer	○	×	○	○	○	×
Label	○	○	○	○	○	○
Battery	○	○	○	○	○	○

○：表示该有毒有害物质在该部件所有均质材料中的含量均在SJ/T11363-2006 标准规定的限量要求以下。

✕: 表示该有毒有害物质至少在该部件的某一均质材料中的含量超出SJ/T11363-2006 标准规定的限量要求。

2.8 India RoHS hazardous substance table

This products described in this guide complies with the “e-waste (Management and Handling) Rules, 2011” of India which is also called India RoHS.

Part Descriptions	Restricted Substances in Product					
	Cd	Pb	Hg	Cr(VI)	PBBs	PBDEs
Frame	○	✕	○	○	○	○
Alloy Parts	○	✕	○	○	○	○
Power Adapter	○	✕	○	○	○	○
Metal Fittings	○	○	○	○	○	○
PCBA	○	✕	○	○	○	○
Capacitor	○	✕	○	○	○	○
Other electronics	○	✕	○	○	○	○
Screen	○	○	○	○	○	○
Solder	○	✕	○	○	○	○
Cable	✕	✕	○	○	○	○
Plastic and Polymer	○	✕	○	○	○	✕
Label	○	○	○	○	○	○
Battery	○	○	○	○	○	○

○: indicates that the content of the toxic and hazardous substance in all the Homogeneous Materials of the part is below the concentration limit requirement as described in the e-waste (Management and Handling) Rules, 2011.

✕: indicates that the content of the toxic and hazardous substance in at least one Homogeneous Material of the

part exceeds the concentration limit requirement as described in S in the e-waste (Management and Handling) Rules, 2011.

2.9 Other Markets

For relevant compliance information/documentation for markets not mentioned above,
please contact Huawei representative