

Regulatory Compliance Statement

BTS3911E

Issue: 01

Date:2015-7-6

HUAWEI TECHNOLOGIES CO., LTD.



Copyright © Huawei Technologies Co., Ltd. 2010. All rights reserved.

No part of this document may be reproduced or transmitted in any form or by any means without prior written consent of Huawei Technologies Co., Ltd.

Trademarks and Permissions



HUAWEI and other Huawei trademarks are trademarks of Huawei Technologies Co., Ltd.

All other trademarks and trade names mentioned in this document are the property of their respective holders.

Notice

The purchased products, services and features are stipulated by the contract made between Huawei and the customer. All or part of the products, services and features described in this document may not be within the purchase scope or the usage scope. Unless otherwise specified in the contract, all statements, information, and recommendations in this document are provided "AS IS" without warranties, guarantees or representations of any kind, either express or implied.

The information in this document is subject to change without notice. Every effort has been made in the preparation of this document to ensure accuracy of the contents, but all statements, information, and recommendations in this document do not constitute the warranty of any kind, express or implied.

Huawei Technologies Co., Ltd.

Address: Huawei Industrial Base
Bantian, Longgang
Shenzhen 518129
People's Republic of China

Website: <http://www.huawei.com>

Email: support@huawei.com

1 Regulatory Compliance Statement

About This Chapter

1.1 Declaration of Conformity to European Directives

1.1 Declaration of Conformity to European Directives

Figure 1-1 Declaration of Conformity to European Directives

None

2 Regulatory Compliance Information

About This Chapter

- 2.1 Regulatory Compliance Standards
- 2.2 European Regulatory Compliance
- 2.3 U.S.A Regulatory Compliance
- 2.4 Canada Regulatory Compliance
- 2.5 Japanese Regulatory Compliance
- 2.6 CISPR 22 Compliance
- 2.7 China RoHS hazardous substance table
- 2.8 India RoHS hazardous substance table
- 2.9 Other Markets

2.1 Regulatory Compliance Standards

Product complies with the standards listed in [Table 2-1](#).

Table 2-1 Regulatory compliance standards

Discipline	Standards
EMC	<ul style="list-style-type: none"> • CISPR22 Class B • CISPR24 • EN55022 Class B • EN50024 • ETSI EN 301 489 Class B • CFR 47 FCC Part 15 Class B • FCC Part 2 • FCC Part 22 • FCC Part 24 • ICES 003 Class B/Class A • AS/NZS CISPR22 Class B • GB9254 Class B • VCCI Class B • CNS 13438 Class B • IEC61000-6-1 • IEC61000-6-3 • EN61000-6-1 • EN61000-6-3
Safety	<ul style="list-style-type: none"> • IEC 60950-1 • IEC60950-22 • IEC/EN60215 • IEC/EN41003 • EN 60950-1 • UL 60950-1 • CSA C22.2 No 60950-1 • AS/NZS 60950.1 • BS EN 60950-1 • IS 13252 • GB4943
Laser safety	<ul style="list-style-type: none"> • FDA rules, 21 CFR 1040.10 and 1040.11 • IEC60825-1, IEC60825-2, EN60825-1, EN60825-2 • GB7247

Discipline	Standards
RF	<ul style="list-style-type: none">• ETSI EN 301 908• ETSI EN 300 328• ETSI EN 301 893• FCC Part 2• FCC Part 24• FCC Part 27• RSS-133• RSS-139
Health	<ul style="list-style-type: none">• ICNIRP Guideline• 1999-519-EC• EN 50385• OET Bulletin 65• FCC Part 1• IEEE Std C95.1• EN 60215• RSS-102
Environmental protection	<ul style="list-style-type: none">• 2011/65/EU (RoHS)• EC NO. 1907/2006 (REACH)• 2002/96/EC (WEEE)
Grounding	<ul style="list-style-type: none">• ITU-T K.27• ETSI EN 300 253

Discipline	Standards
<p>NOTE</p> <p>EMC: electromagnetic compatibility</p> <p>NEBS: Network Equipment Build Standard</p> <p>RF: radio frequency</p> <p>CISPR: International Special Committee on Radio Interference</p> <p>EN: European Standard</p> <p>ETSI: European Telecommunications Standards Institute</p> <p>CFR: Code of Federal Regulations</p> <p>FCC: Federal Communication Commission</p> <p>IEC: International Electrotechnical Commission</p> <p>AS/NZS: Australian/New Zealand Standard</p> <p>VCCI: Voluntary Control Council for Interference</p> <p>CNS: Chinese National Standard</p> <p>UL: Underwriters Laboratories</p> <p>CSA: Canadian Standards Association</p> <p>BS: British Standard</p> <p>IS: Indian Standard</p> <p>GR: General Requirement</p> <p>FDA: Food and Drug Administration</p> <p>BTS: Base Transceiver Station</p> <p>GSM: Global System for Mobile communications</p> <p>WLAN: wireless local area network</p> <p>ICNIRP: International Commission on Non-Ionizing Radiation Protection</p> <p>OET: Office of Engineering Technology</p> <p>IEEE: Institute of Electrical and Electronics Engineers</p> <p>RoHS: restriction of the use of certain hazardous substances</p>	

2.2 European Regulatory Compliance

Product complies with the following European directives and regulations.

- 2004/108/EC (EMC)
- 2006/95/EC (low voltage)
- 1999/5/EC (R&TTE)
- 2011/65/EU (RoHS)
- EC NO. 1907/2006 (REACH)
- 2002/96/EC (WEEE)

Product complies with Directive 2002/95/EC, 2011/65/EU and other similar regulations from the countries outside the European Union, on the RoHS in electrical and electronic equipment. The device does not contain lead, mercury, cadmium, and hexavalent chromium and brominated flame retardants (Polybrominated Biphenyls (PBB) or Polybrominated Diphenyl Ethers (PBDE)) except for those exempted applications allowed by RoHS directive for technical reasons.

Product complies with Regulation EC NO. 1907/2006 (REACH) and other similar regulations from the countries outside the European Union. Huawei will notify to the European Chemical Agency (ECHA) or the customer when necessary and regulation requires.

Product complies with Directive 2002/96/EC on waste electrical and electronic equipment (WEEE). Huawei is responsible for recycling its end-of-life devices, and please contact Huawei local service center when recycling is required. Huawei strictly complies with the EU Waste Electrical and Electronic Equipment Directive (WEEE Directive) and electronic waste management regulations enacted by different countries worldwide. In addition, Huawei has established a system for recycling and reuse of electronic wastes, and it can provide service of dismantling and recycling for WEEE. By Huawei recycling system, the waste can be handled environmentally and the resource can be recycled and reused fully, which is also Huawei WEEE stratagem in the word. Most of the materials in product are recyclable, and our packaging is designed to be recycled and should be handled in accordance with your local recycling policies.

In accordance with Article 11(2) in Directive 2002/96/EC (WEEE), products were marked with the following symbol: a cross-out wheeled waste bin with a bar beneath as below:

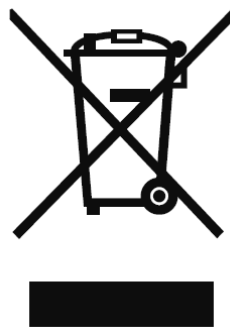

In order to avoid the possibility of exceeding the Europe radio frequency exposure limits, human proximity to the equipment shall not be less than 0.124 m

2.3 U.S.A Regulatory Compliance

2.3.1 Safety compliance Mark

2.3.2 FCC

2.3.1 Safety compliance Mark



2.3.2FCC

Product complies with Part 15 of the FCC Rules. Operation is subject to the following two conditions:

- This device does not cause harmful interference.
- This device must accept any interference received, including interference that may cause undesired operation.

If this device is modified without authorization from Huawei, the device may no longer comply with FCC requirements for Class B digital devices. In that a case, your right to use the device may be limited by FCC regulations. Moreover, you may be required to correct any interference to radio or television communications at your own expense.

This device has been tested and found to comply with the limits for a Class B digital device, pursuant to Part 15 of the FCC rules. These limits are designed to provide reasonable protection against harmful interference in a residential installation.

This device generates, uses and radiates radio frequency energy. If it is not installed and used in accordance with the instructions, it may cause harmful interference to radio communications.

However, there is no guarantee that interference will not occur in a particular installation. If this device does cause harmful interference to radio or television reception, which can be determined by turning the device off and on, the user may take one or more of the following measures:

- Reorient or relocate the receiving antenna.
- Reinforce the separation between the device and receiver.
- Connect the device into an outlet on a circuit different from that to which the receiver is connected.
- Consult the dealer or an experienced radio or TV technician for assistance.

In order to avoid the possibility of exceeding the 47CFR FCC Part 1 & OET Bulletin 65 radio frequency exposure limits, human proximity to the equipment shall not be less than 1.78 m

2.4 Canada Regulatory Compliance

2.4.1 RSS-Gen statement

This device complies with Industry Canada licence-exempt RSS standard(s).

Operation is subject to the following two conditions: (1) this device may not cause interference, and (2) this device must accept any interference, including interference that may cause undesired operation of the device.

Le présent appareil est conforme aux CNR d'Industrie Canada applicables aux appareils radio exempts de licence. L'exploitation est autorisée aux deux conditions suivantes : (1) l'appareil ne doit pas produire de brouillage, et (2) l'utilisateur de l'appareil doit accepter tout brouillage radioélectrique subi, même si le brouillage est susceptible d'en compromettre le fonctionnement.

2.4.2 RSS-102 statement

This device is designed and manufactured not to exceed the emission limits for exposure to radio frequency (RF) energy set by Industrial Canada and meets the requirements for radiation exposure limits set forth for an uncontrolled environment.

In order to avoid the possibility of exceeding the Industrial Canada radio frequency exposure limits, human proximity to the equipment shall not be less than 2.58 m

Cet appareil est conçu et fabriqué pour ne pas dépasser les limites d'émission pour l'exposition à la fréquence radio (RF) de l'énergie fixé par l'Industrielle Canada et répond aux exigences en matière de limites d'exposition aux rayonnements définies pour un environnement non contrôlé.

Afin d'éviter la possibilité de dépasser les limites d'exposition aux fréquences radio industrielle du Canada, la proximité humaine pour l'appareil nedoit pas être inférieure à 2.58 m

2.5 Japanese Regulatory Compliance

2.5.1 VCCI

2.5.1VCCI

Product complies with VCCI Class B by Information Technology Equipment (ITE).

The preceding translates as follows:

This is a Class B product based on the standard of the Voluntary Control Council for Interference by Information Technology Equipment (VCCI).If this product is used

Near a radio or television receiver in a domestic environment. It may cause radio

Interference.Install and use the equipment according to the instruction manual.

2.6 CISPR 22 Compliance

Product complies with CISPR 22 for Class B by the ITE.

2.7 China RoHS hazardous substance table

This products described in this guide complies with “the Administration on the Control of Pollution Caused by Electronic Information Products” which is also called China RoHS

部件名称	产品中有害物质或元素的名称及含量					
	镉	铅	汞	六价铬	多溴联苯	多溴联苯醚
Frame	○	×	○	○	○	○
Alloy Parts	○	×	○	○	○	○
Power Adapter	○	×	○	○	○	○
Metal Fittings	○	○	○	○	○	○
PCBA	○	×	○	○	○	○
Capacitor	○	×	○	○	○	○
Other electronics	○	×	○	○	○	○
Screen	○	○	○	○	○	○
Solder	○	×	○	○	○	○
Cable	×	×	○	○	○	○
Plastic and Polymer	○	×	○	○	○	×
Label	○	○	○	○	○	○
Battery	○	○	○	○	○	○

○：表示该有毒有害物质在该部件所有均质材料中的含量均在SJ/T11363-2006 标准规定的限量要求以下。

✕: 表示该有毒有害物质至少在该部件的某一均质材料中的含量超出SJ/T11363-2006 标准规定的限量要求。

2.8 India RoHS hazardous substance table

This products described in this guide complies with the “e-waste (Management and Handling) Rules, 2011” of India which is also called India RoHS.

Part Descriptions	Restricted Substances in Product					
	Cd	Pb	Hg	Cr(VI)	PBBs	PBDEs
Frame	○	✕	○	○	○	○
Alloy Parts	○	✕	○	○	○	○
Power Adapter	○	✕	○	○	○	○
Metal Fittings	○	○	○	○	○	○
PCBA	○	✕	○	○	○	○
Capacitor	○	✕	○	○	○	○
Other electronics	○	✕	○	○	○	○
Screen	○	○	○	○	○	○
Solder	○	✕	○	○	○	○
Cable	✕	✕	○	○	○	○
Plastic and Polymer	○	✕	○	○	○	✕
Label	○	○	○	○	○	○
Battery	○	○	○	○	○	○

○: indicates that the content of the toxic and hazardous substance in all the Homogeneous Materials of the part is below the concentration limit requirement as described in the e-waste (Management and Handling) Rules, 2011.

✕: indicates that the content of the toxic and hazardous substance in at least one Homogeneous Material of the

part exceeds the concentration limit requirement as described in S in the e-waste (Management and Handling) Rules, 2011.

2.9 Other Markets

For relevant compliance information/documentation for markets not mentioned above,
please contact Huawei representative



BTS3911E

V100R011C00

Hardware Description

Issue **Draft A**

Date **2015-07-30**

Copyright © Huawei Technologies Co., Ltd. 2015. All rights reserved.

No part of this document may be reproduced or transmitted in any form or by any means without prior written consent of Huawei Technologies Co., Ltd.

Trademarks and Permissions



HUAWEI and other Huawei trademarks are trademarks of Huawei Technologies Co., Ltd.

All other trademarks and trade names mentioned in this document are the property of their respective holders.

Notice

The purchased products, services and features are stipulated by the contract made between Huawei and the customer. All or part of the products, services and features described in this document may not be within the purchase scope or the usage scope. Unless otherwise specified in the contract, all statements, information, and recommendations in this document are provided "AS IS" without warranties, guarantees or representations of any kind, either express or implied.

The information in this document is subject to change without notice. Every effort has been made in the preparation of this document to ensure accuracy of the contents, but all statements, information, and recommendations in this document do not constitute a warranty of any kind, express or implied.

Huawei Technologies Co., Ltd.

Address: Huawei Industrial Base
Bantian, Longgang
Shenzhen 518129
People's Republic of China

Website: <http://www.huawei.com>

Email: support@huawei.com

Contents

1 About This Document.....	1
2 Changes in BTS3911E Hardware Description.....	2
3 BTS3911E Equipment.....	3
3.1 Appearance.....	4
3.2 Ports and Indicators.....	5
4 BTS3911E Cables.....	9
4.1 Cable List.....	10
4.2 PGND Cable.....	11
4.3 Power Cable.....	11
4.4 FE/GE Ethernet Cable.....	12
4.5 FE/GE Fiber Optic Cable.....	14
4.6 Alarm Cable.....	16
4.7 (Optional) RF Jumper.....	17
5 (Optional) GPS Antenna.....	18
6 Typical Networking and Cable Connection.....	20
6.1 Typical Networking.....	21
6.2 Cable Connection Principles.....	22
7 Power Requirements.....	23
8 Engineering Specifications.....	24

1 About This Document

Introduction

This document describes the BTS3911E and related information, such as networking, cables, cable connections, and specifications, to provide guidelines for planning and deploying the BTS3911E.

Product Version

The following table lists the product versions related to this document.

Product Name	Solution Version	Product Version
BTS3911E	<ul style="list-style-type: none">● SRAN11.0● RAN18.0● eRAN11.0	V100R011C00

Intended Audience

This document is intended for:

- BTS3911E installation engineers
- System engineers
- Site maintenance engineers

2 Changes in BTS3911E Hardware Description

This section describes the changes in *BTS3911E Hardware Description*.

Draft A (2015-07-30)

This is a draft.

3 BTS3911E Equipment

This section describes the appearance, ports, and indicators of a BTS3911E.

[3.1 Appearance](#)

[3.2 Ports and Indicators](#)

3.1 Appearance

This section describes the appearance and dimensions of a BTS3911E.

Figure 3-1 shows the appearance of BTS3911E.

Figure 3-1 BTS3911E appearance

BTS3911E
with internal antennas

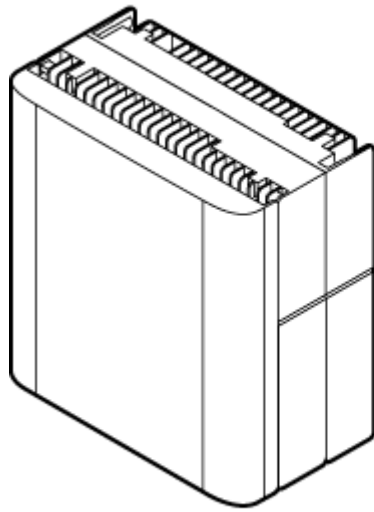

BTS3911E
without internal antennas

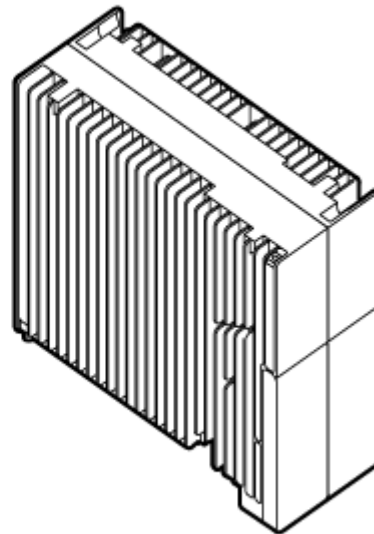

PAX14C0000

Figure 3-2 shows its dimensions.

Figure 3-2 BTS3911E dimensions

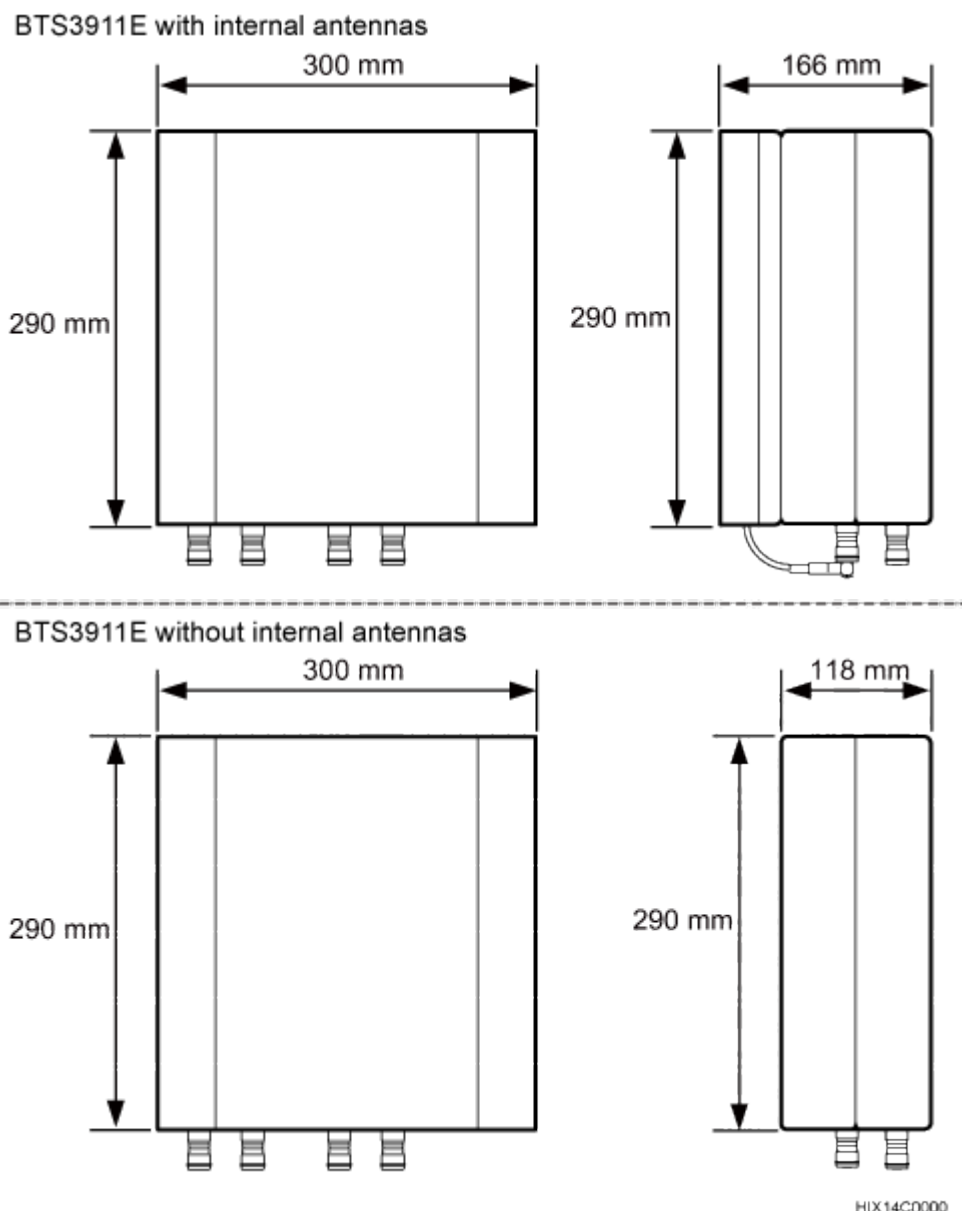

3.2 Ports and Indicators

This section describes the BTS3911E ports (on the bottom or the side maintenance cavity) and indicators (on the bottom).

Positions

Figure 3-3 shows the positions of the BTS3911E ports and indicators.

Figure 3-3 Positions of the BTS3911E ports and indicators

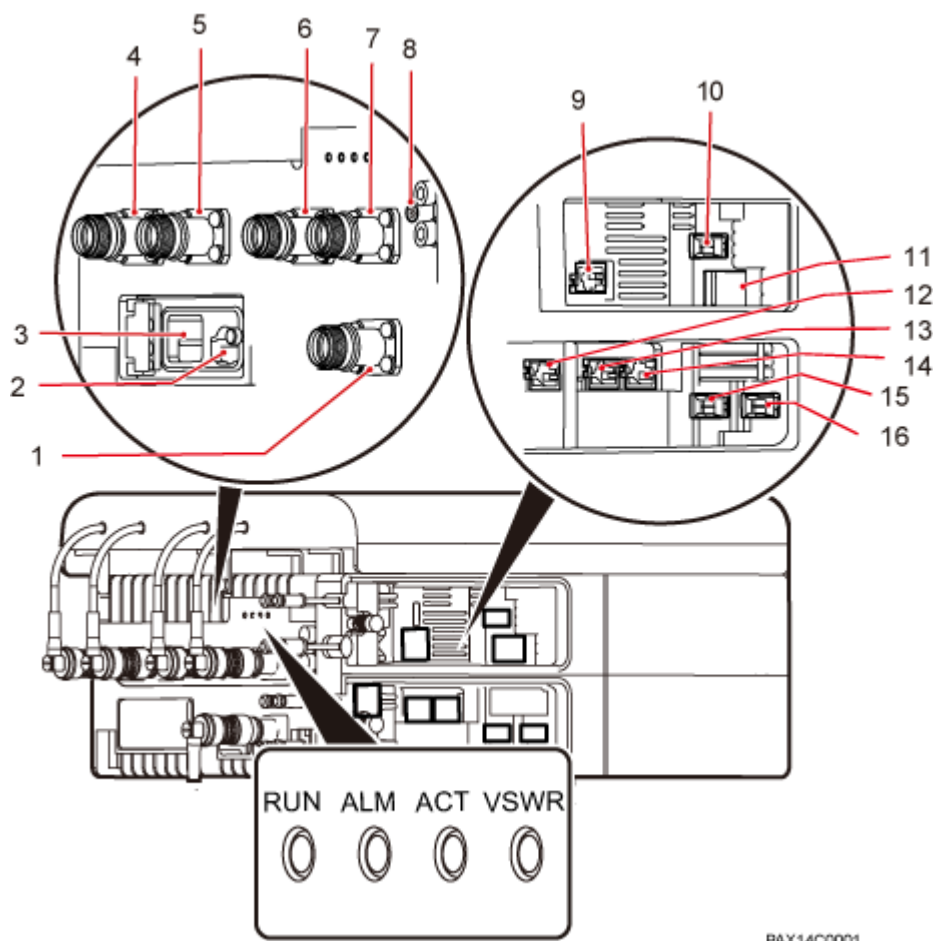

PAX14C0001

(1) GPS	(2) TF card	(3) USB WIFI	(4) ANT D
(5) ANT C	(6) ANT B	(7) ANT A	(8) Ground terminal
(9) EXT_ALM	(10) CPRI	(11) PWR	(12) FE/GE0
(13) FE/GE1	(14) DBG	(15) FE/GE2	(16) FE/GE3

Ports

Table 3-1 describes the BTS3911E ports.

Table 3-1 BTS3911E ports

Port	Description
PWR	Power input port

Port	Description
CPRI	Reserved port
EXT-ALM	Dry contact alarm port for monitoring the alarm status of external devices
TF	Anchor slot for the trans flash card (TF card, also called micro SD card) for BTS3911E deployment
DBG	Commissioning port
FE/GE0	Electrical port
FE/GE1	Electrical port
FE/GE2	Optical port
FE/GE3	Optical port
ANT A	Port A used to transmit and receive RF signals
ANT B	Port B used to transmit and receive RF signals
ANT C	Port C used to transmit and receive RF signals
ANT D	Port D used to transmit and receive RF signals
GPS	Port for connecting GPS antennas to achieve clock synchronization
USB WIFI	Wi-Fi port for zero-touch maintenance and deployment
	Ground terminal

Indicators

A BTS3911E has four indicators. [Table 3-2](#) describes the indicators.

NOTE

The BTS3911E indicators can be turned on or off by following instructions provided in *BTS3911E Site Maintenance Guide*.

Table 3-2 BTS3911E indicators

Indicator	Meaning	Status	Description
RUN	Operating status	Steady green	There is power supply, but the BTS3911E is faulty.
		Off	There is no power supply, or the BTS3911E is faulty.

Indicator	Meaning	Status	Description
		Blinking green (on for 1s and off for 1s)	The BTS3911E is running properly.
		Blinking green (on for 0.125s and off for 0.125s)	Software is being loaded to the BTS3911E, or the BTS3911E is not started.
ALM	Alarm status	Steady red	Alarms are generated, and the BTS3911E must be replaced.
		Blinking red (on for 1s and off for 1s)	An alarm is generated. The alarm may be caused by faults in related modules or ports. Therefore, the necessity for BTS3911E replacement is uncertain.
		Off	No alarm is generated.
ACT	Service status	Steady green	The BTS3911E is activated and working properly.
		Off	The BTS3911E is deactivated or is not running.
		Blinking green (on for 0.125s and off for 0.125s)	The operation and maintenance link (OML) is disconnected.
		Blinking green (on for 2s and off for 2s)	Services are not available, for example, the cells or service links are not ready for service provisioning.
		Blinking green (on for 1s and off for 1s)	The BTS3911E is being tested, for example, in an RRU VSWR test by using a USB flash drive.
VSWR	VSWR alarm status	Steady red	A VSWR alarm is generated, and the BTS3911E may be replaced.
		Off	No VSWR alarm is generated.

4 BTS3911E Cables

This section describes the appearance, core wire types, and installation positions of BTS3911E cables.

[4.1 Cable List](#)

[4.2 PGND Cable](#)

[4.3 Power Cable](#)

[4.4 FE/GE Ethernet Cable](#)

[4.5 FE/GE Fiber Optic Cable](#)

[4.6 Alarm Cable](#)

[4.7 \(Optional\) RF Jumper](#)

4.1 Cable List

This section describes the connection positions and connector types of BTS3911E cables.

BTS3911E cables include PGND cables, power cables, transmission cables, RF jumpers, GPS signal cables, and alarm cables, as listed in [Table 4-1](#).

Table 4-1 BTS3911E cable list

Cable	One End		The Other End	
	Connector	Installation Position (Equipment/Module/Port)	Connector	Installation Position (Equipment/Module/Port)
4.2 PGND Cable	OT terminal (M6, 6 mm ²)	Ground terminal of the BTS3911E	OT terminal (M8, 6 mm ²)	External ground bar
4.3 Power Cable	Tool-less female connector AC-EPC1 (pressfit type)	PWR port on the BTS3911E maintenance cavity	Depends on the external power supply equipment.	External power supply equipment
4.4 FE/GE Ethernet Cable	RJ45 connector	FE/GE0 or FE/GE1 port on the BTS3911E maintenance cavity	RJ45 connector	External transmission equipment
			RJ45 connector	FE/GE0 or FE/GE1 port on the BTS3911E maintenance cavity
4.5 FE/GE Fiber Optic Cable	DLC connector	FE/GE2 or FE/GE3 port on the BTS3911E maintenance cavity	FC, LC, or SC connector	External transmission equipment
			DLC connector	FE/GE2 or FE/GE3 port on the BTS3911E maintenance cavity
4.6 Alarm Cable	RJ45 connector	EXT-ALM port on the BTS3911E maintenance cavity	Depends on the external monitored equipment	External monitored equipment

<p>4.7 (Optional) RF Jumper</p>	<p>Smart-type N male connector</p>	<p>ANT A, ANT B, ANT C, or ANT D port on the BTS3911E</p>	<p>Type N male connector</p>	<p>External antenna system</p>
--	------------------------------------	---	------------------------------	--------------------------------

4.2 PGND Cable

A PGND cable connects the ground terminal of a BTS3911E to a ground bar, providing ground protection for the BTS3911E.

Appearance

Figure 4-1 shows the appearance of a PGND cable with connectors.

Figure 4-1 PGND cable appearance



(1) OT terminal

Cable Description

Table 4-2 describes the BTS3911E PGND cable.

Table 4-2 PGND cable description

Cable	One End	The Other End	Color
PGND cable	OT terminal (M6, 6 mm ²)	OT terminal (M8, 6 mm ²)	Yellow and green or green

4.3 Power Cable

A power cable connects the BTS3911E to the external AC power supply equipment.

Appearance

A tool-less female connector (pressfit type) needs to be added to one end of a BTS3911E power cable onsite. A corresponding terminal needs to be added to the other end based on the port on the external power supply equipment. **Figure 4-2** shows the appearance of a BTS3911E power cable.

Figure 4-2 Power cable appearance

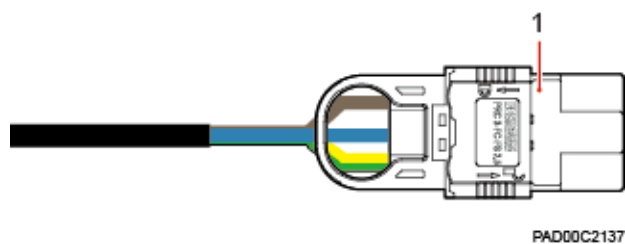

(1) Tool-less female connector (pressfit type)

Cable Description

Table 4-3 describes the BTS3911E power cable.

Table 4-3 Power cable description

Cable	Core Wire	Wire Color	Cable Specifications
Power cable	L	Brown	1.5 mm ² to 2.5 mm ²
	N	Blue	
	PE	Yellow and green	

NOTE

The color and structure of a power cable varies with countries and regions. A locally purchased power cable must be a pure copper outdoor three-core cable that has a cross-sectional area of 1.5 mm² to 2.5 mm² and a maximum outer diameter of 8.9 mm to 10.2 mm and complies with local specifications.

4.4 FE/GE Ethernet Cable

An FE/GE Ethernet cable transmits FE/GE signals between a BTS3911E and the external transmission equipment or between two BTS3911Es.

 **NOTE**

FE/GE Ethernet cables can be used for transmission over a maximum distance of 100 m.

Appearance

An FE/GE Ethernet cable is a Category 5e or above shielded foil twisted pair (SFTP) cable in compliance with TIA/EIA-568B. It is terminated with an RJ45 connector at both ends.

 **NOTE**

Ethernet cables of a higher level can also be used. For detailed specifications, see standards related to Ethernet cables.

Figure 4-3 shows the structure of an FE/GE Ethernet cable.

Figure 4-3 Structure of an FE/GE Ethernet cable

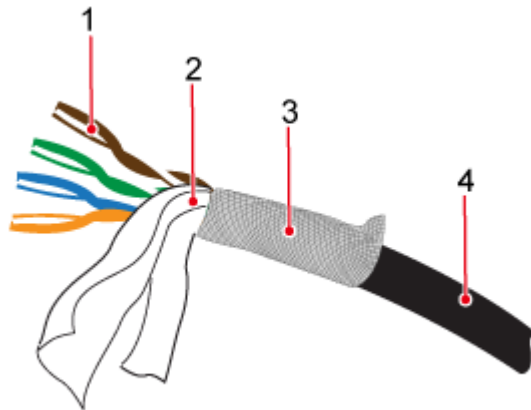

(1) Core wire	(2) Aluminum foil	(3) Braided layer	(4) Jacket
---------------	-------------------	-------------------	------------

Figure 4-4 shows the appearance of an FE/GE Ethernet cable.

Figure 4-4 Appearance of an FE/GE Ethernet cable



PAD00C2083

(1) RJ45 connector

Cable Description

Table 4-4 describes the pin assignment of an FE/GE Ethernet cable.

Table 4-4 Pin assignment of an FE/GE Ethernet cable

Pin on the RJ45 Connector	Wire Color	Wire Type	Pin on the RJ45 Connector
X1.2	Orange	Twisted pair	X2.2
X1.1	White/orange		X2.1
X1.6	Green	Twisted pair	X2.6
X1.3	White/green		X2.3
X1.4	Blue	Twisted pair	X2.4
X1.5	White/blue		X2.5
X1.8	Brown	Twisted pair	X2.8
X1.7	White/brown		X2.7

4.5 FE/GE Fiber Optic Cable

An FE/GE fiber optic cable transmits optical signals between a BTS3911E and the external transmission equipment or between two BTS3911Es.

 **NOTE**

A standard fiber optic cable is 70 m long or shorter.

Connecting a BTS3911E and a Transmission Device

An FE/GE fiber optic cable connecting a BTS3911E and a transmission device has a DLC connector at one end, and FC, LC, or SC connectors on the other end, as shown in **Figure 4-5**.

Figure 4-5 FE/GE fiber optic cable (1)

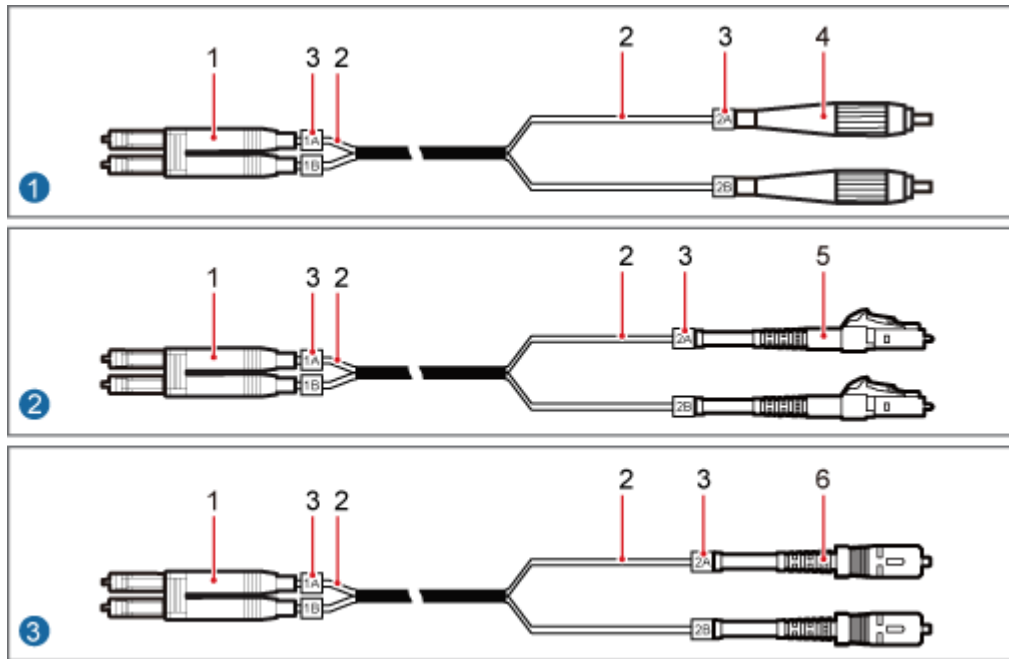

PAR06C4002

(1) DLC connector	(2) Branch fiber optic cable	(3) Branch fiber optic cable label
(4) FC connector	(5) LC connector	(6) SC connector

Connecting Two BTS3911Es

An FE/GE fiber optic cable connecting two BTS3911Es has a DLC connector at each end, as shown in [Figure 4-6](#).

Figure 4-6 FE/GE fiber optic cable (2)



(1) DLC connector	(2) Branch fiber optic cable	(3) Branch fiber optic cable label
-------------------	------------------------------	------------------------------------

4.6 Alarm Cable

An alarm cable transmits alarm signals from external devices to a BTS3911E so that the BTS3911E can monitor the operating status of the external devices.

Appearance

An RJ45 connector needs to be added to one end of a BTS3911E alarm cable. A corresponding terminal needs to be added to the other end based on the port on the external monitored equipment. **Figure 4-7** shows the appearance of a BTS3911E alarm cable.

Figure 4-7 Alarm cable appearance

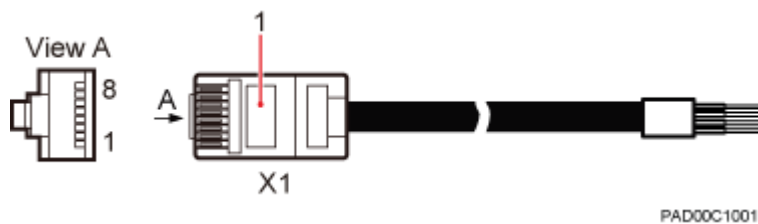

(1) RJ45 connector

Cable Description

Table 4-5 describes the pin assignment of an alarm cable.

Table 4-5 Pin assignment of an alarm cable

Pin	Wire Color	Wire Type	Description
X1.1	White/Orange	Twisted pair	Boolean input 0+
X1.2	Orange		Boolean input 0 - (GND)
X1.3	White/Green	Twisted pair	Boolean input 1+
X1.6	Green		Boolean input 1 - (GND)
X1.5	White/blue	Twisted pair	Boolean input 2+
X1.4	Blue		Boolean input 2 - (GND)
X1.7	White/Brown	Twisted pair	Boolean input 3+

Pin	Wire Color	Wire Type	Description
X1.8	Brown		Boolean input 3 - (GND)

4.7 (Optional) RF Jumper

The 1/2" RF jumper is used for the BTS3911E to transmit and receive RF signals.

An RF jumper has a type N male connector at one end and a Smart-type N male connector at the other end. [Figure 4-8](#) shows the appearance of an RF jumper.

Figure 4-8 RF jumper appearance



(1) Smart-type N male connector	(2) Type N male connector
---------------------------------	---------------------------

5 (Optional) GPS Antenna

A GPS antenna connects to the BTS3911E for clock synchronization. The GPS antenna is optional.

Appearance

A GPS antenna has a Smart-type N male connector at one end. [Figure 5-1](#) shows the appearance of a GPS antenna.

Figure 5-1 GPS antenna appearance

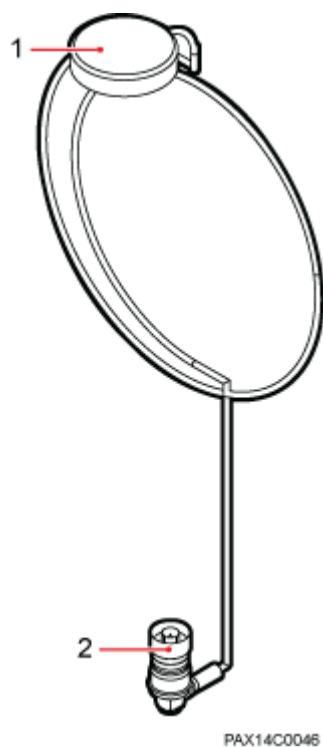

(1) GPS antenna	(2) Smart-type N male connector
-----------------	---------------------------------

6 Typical Networking and Cable Connection

This section describes the BTS3911E networking modes and cable connection principles.

[6.1 Typical Networking](#)

[6.2 Cable Connection Principles](#)

6.1 Typical Networking

The BTS3911E supports the star and chain topologies.

Star Topology

The star topology is the most commonly used topology and applies to densely populated areas. [Figure 6-1](#)

Figure 6-1 Star topology

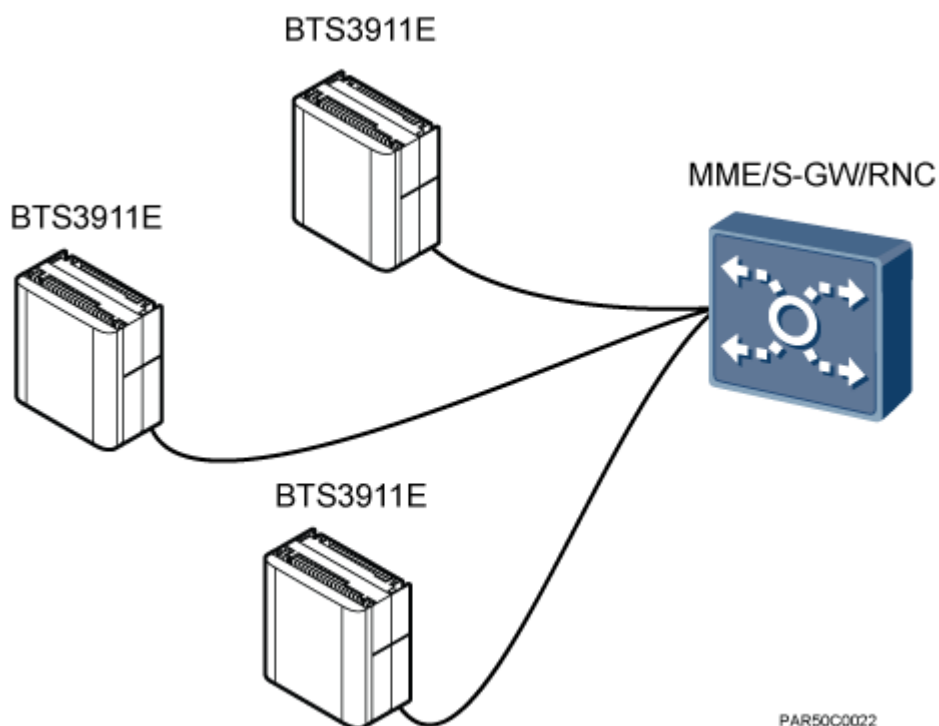

Chain Topology

The chain topology applies to belt-shaped and sparsely populated areas, such as areas along highways and railways. [Figure 6-2](#)

Figure 6-2 Chain topology

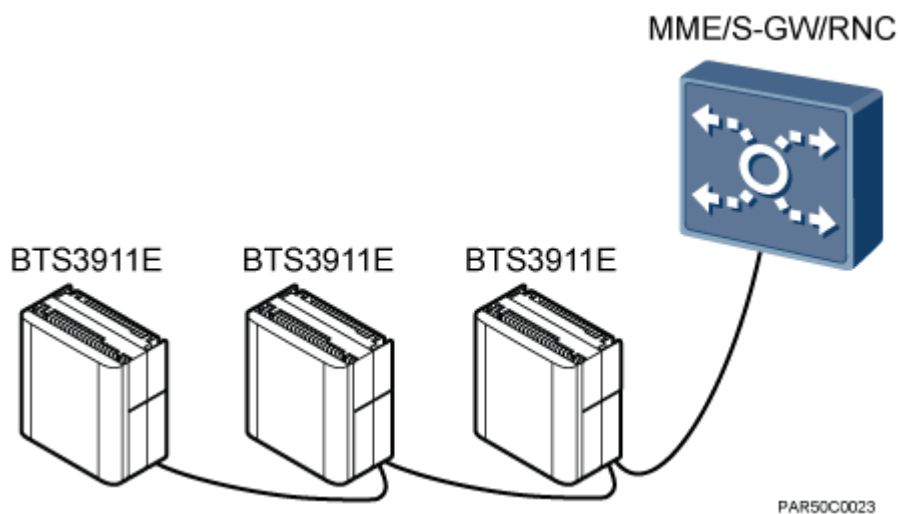

6.2 Cable Connection Principles

This section describes the connection principles for the PGND cable, power cable, transmission cable, alarm cable, and RF jumper.

PGND Cable

The PGND cable length must not exceed 30 m.

Power Cable

The power cable length must not exceed 100 m.

Transmission Cable

- An Ethernet cable or fiber optic cable can be used for transmission between a BTS3911E and the MME/S-GW/RNC. A standard fiber optic cable is 70 m long or shorter. An Ethernet cable must be made onsite, with a maximum length of 100 m.
- A maximum of three levels of BTS3911Es can be cascaded over Ethernet cables or (recommended) fiber optic cables. The maximum distance between two BTS3911Es cascaded over an Ethernet cable is 100 m.

Alarm Cable

The alarm cable length must not exceed 100 m.

RF Jumper

The RF jumper length depends on scenario-specific coverage requirements and must not exceed 10 m.

7 Power Requirements

This section describes the requirements on the upper-level (customer-provided) circuit breakers and cross-sectional areas of power cables for the BTS3911Es.

Slow-blow fuses of the gL (DIN VDE)/gG (IEC) class in accordance with IEC60269-1 are recommended. Fuses of the same specifications must be configured for L and N wires for the sake of O&M security.

Type C bipolar circuit breakers in accordance with IEC60934 are recommended. Circuit breakers must be configured for L and N wires for the sake of O&M security.

Table 7-1 describes the recommended specifications.

Table 7-1 Requirements on the upper-level circuit breakers and power cables

Power Supply	Current of the Upper-level AC Circuit Breakers (or Fuses)	Cross-Sectional Area of the Input Power Cable
220 V AC single-phase	<ul style="list-style-type: none">● Minimum value: 5 A● Recommended value: 16 A● Maximum value: 20 A	1.5 mm ² to 2.5 mm ²
110 V AC dual-live-wire		
110 V AC single-phase		

 **NOTE**

- The requirements provided in the preceding table are based on the peak power of a BTS3911E and do not represent power consumption when the BTS3911E is running.
- Minimum value: Ensures that a BTS3911E can work normally under normal circumstances. However, lightning strikes or abnormal voltage fluctuations may trip the circuit breaker or melt the fuse.
- Recommended value: Ensures that a BTS3911E can work normally under normal circumstances and that the circuit breaker does not trip in the event of lightning strikes or abnormal voltage fluctuations.
- Maximum value: Indicates the maximum rated current allowed in the product design.

8 Engineering Specifications

BTS3911E engineering specifications include power supply specifications, equipment specifications, environment specifications, surge protection specifications, and standards compliance.

For more details, see *BTS3911E Technical Description*.

Power Supply Specifications

Table 8-1 describes the input and output power specifications of a BTS3911E.

Table 8-1 Power supply specifications

Item	Specifications
Input power	100 V AC to 240 V AC
Output power (PoE)	-37 V DC to -57 V DC

Equipment Specifications

Table 8-2 describes the dimensions and weight of a BTS3911E.

Table 8-2 Equipment specifications

Item	Dimensions (W x H x D)	Weight
BTS3911E with internal antennas	300 mm x 290 mm x 166 mm	≤ 13 kg
BTS3911E without internal antennas	300 mm x 290 mm x 118 mm	≤ 11 kg

Environment Specifications

Table 8-3 describes the environment specifications of a BTS3911E.

Table 8-3 Environment specifications

Item	Specifications
Operating temperature	-40°C to +50°C (with solar radiation) -40°C to +45°C (without solar radiation)
Storage temperature	-40°C to +70°C
Relative humidity	5% RH to 95% RH
Absolute humidity	(1 to 30) g/m ³
Altitude	-60 m to +1800 m
Operating atmospheric pressure	70 kPa to 106 kPa
Operating environment	European Telecommunication Standards (ETS) 30 019-1-4 Class4.1
Storage environment	ETSI EN300019-1-1 class1.2 "Weather protected, not temperature-controlled storage locations"
Transportation environment	ETSI EN300019-1-2 class 2.3 "Public transportation"
Protection rating	IP65
Anti-seismic performance	IEC 60068-2-57 Environmental testing – Part 2-57: Tests – Test Ff: Vibration – Time-history method ETSI EN300019-2-4 YD5083-99: Interim Provisions for Test of Anti-seismic Performances of Telecommunications Equipment (telecommunications industry standard in People's Republic of China)
Protection against the moisture, salt spray, and fungus	IEC60068-2-30 IEC60068-2-52 IEC60068-2-10
Storage time	To avoid product degradation, it is a good practice to put the BTS3911E into use within the first year of storage.

Surge Protection Specifications

Table 8-4 describes the surge protection specifications of the PWR port on a BTS3911E.

Table 8-4 Surge protection specifications of the PWR port

Port	Surge Protection Mode	Specifications
PWR	Differential mode	20 kA (8/20us)
	Common mode	20 kA (8/20us)

Standards Compliance

Table 8-5 describes the standards with which the BTS3911E complies.

Table 8-5 Standards with which the BTS3911E complies

Item	Specifications
EMC	<p>The BTS3911E complies with the following standards related to electromagnetic compatibility:</p> <ul style="list-style-type: none"> ● CISPR 22 ● EN 55022 ● EN 301 489-17 ● EN 301 489-23 ● CISPR 24 ● IEC 61000-4-2 ● IEC 61000-4-3 ● IEC 61000-4-4 ● IEC 61000-4-5 ● IEC 61000-4-6 ● IEC 61000-4-29 ● GB 9254 ● ETSI 301 489-1 ● VCCI V-3
3GPP	R99, R4, R5, R6, R7, R8, R9, and R10
Environmental standards	RoHS
Surge protection standards	IEC61000-4-5, IEC 61312-1, and YD 5098
Protection standards	YD 5098, YD 5068-98, and IEC 61000-4-5

Item	Specifications
Safety standards	UL60950-1, IEC60950-1, EN60950-1, AS/NZS60950-1, UL60950-22, IEC60950-22, EN60950-22, and AS/NZS60950-22
Environment standards	IEC 68-2-1, IEC 68-2-2, IEC60068-2-2, ETSI EN300019-1-1, ETSI EN300019-1-2, ETSI EN300019-1-4, and ETSI EN300019-2-4

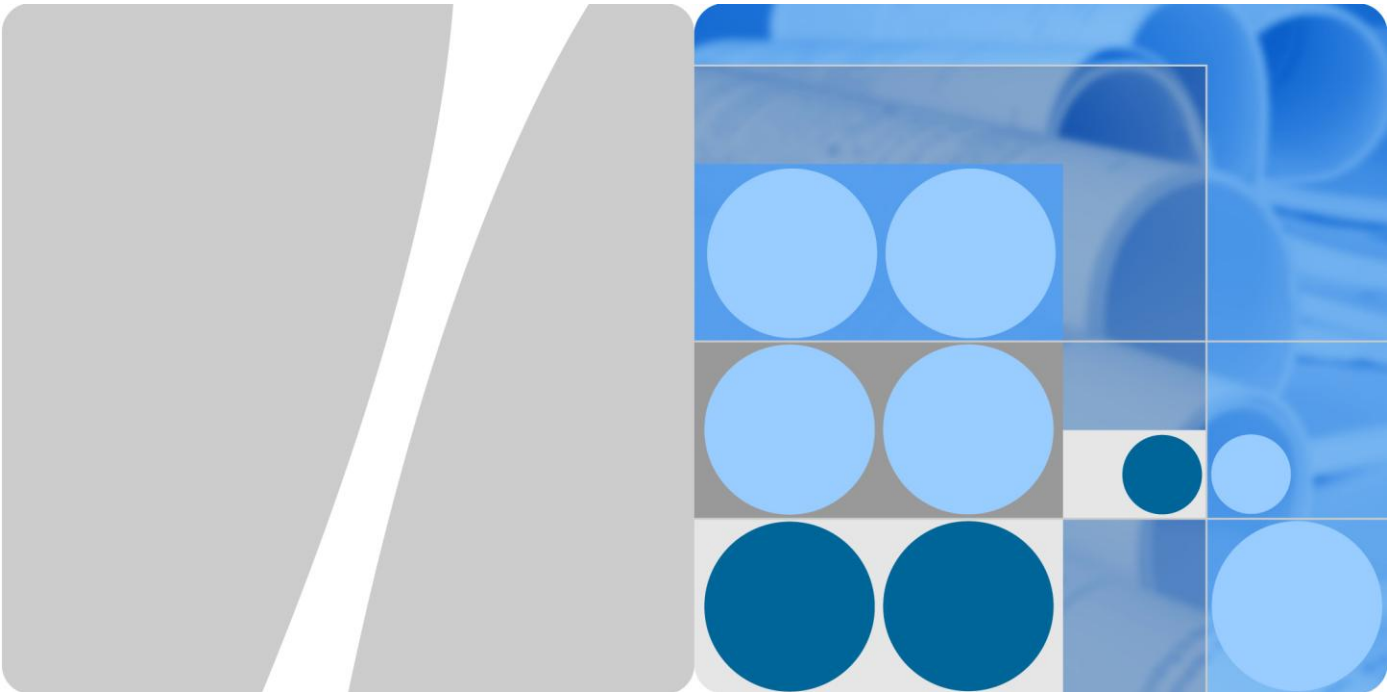

BTS3911E
V100R011C00
Installation Guide

Issue **Draft A**
Date **2015-07-30**

Copyright © Huawei Technologies Co., Ltd. 2015. All rights reserved.

No part of this document may be reproduced or transmitted in any form or by any means without prior written consent of Huawei Technologies Co., Ltd.

Trademarks and Permissions



and other Huawei trademarks are trademarks of Huawei Technologies Co., Ltd.

All other trademarks and trade names mentioned in this document are the property of their respective holders.

Notice

The purchased products, services and features are stipulated by the contract made between Huawei and the customer. All or part of the products, services and features described in this document may not be within the purchase scope or the usage scope. Unless otherwise specified in the contract, all statements, information, and recommendations in this document are provided "AS IS" without warranties, guarantees or representations of any kind, either express or implied.

The information in this document is subject to change without notice. Every effort has been made in the preparation of this document to ensure accuracy of the contents, but all statements, information, and recommendations in this document do not constitute a warranty of any kind, express or implied.

Huawei Technologies Co., Ltd.

Address: Huawei Industrial Base
Bantian, Longgang
Shenzhen 518129
People's Republic of China

Website: <http://www.huawei.com>

Email: support@huawei.com

Contents

1 BTS3911E Installation Guide	1
1.1 Changes in BTS3911E Installation Guide	2
1.2 Installation Preparations	2
1.2.1 Installation Environment.....	2
1.2.2 Reference Documents	3
1.2.3 Tools and Instruments	3
1.2.4 Skills and Requirements for Installation Personnel	5
1.2.5 Installation Scenarios	5
1.2.6 Installation Clearance Requirements	7
1.3 Unpacking Inspection	8
1.4 Obtaining the SN	10
1.5 Installation Process	11
1.6 (Optional) Installing a TF Card.....	12
1.7 Installing a BTS3911E.....	14
1.7.1 Mounting Kits	14
1.7.2 Installing a BTS3911E on a Pole	15
1.7.3 Installing a BTS3911E on a Wall	17
1.8 Installing Cables	20
1.8.1 Cabling Requirements.....	20
1.8.2 Cable Connections	22
1.8.3 Installing a PGND Cable	23
1.8.4 (Optional) Installing an RF Jumper	25
1.8.5 Opening the Maintenance Cavity Covers	26
1.8.6 Installing a Power Cable	28
1.8.7 Installing an Alarm Cable	30
1.8.8 Installing Transmission Cables	31
1.8.8.1 Installing an FE/GE Fiber Optic Cable.....	31
1.8.8.2 Installing an FE/GE Ethernet Cable.....	33
1.8.8.3 (Optional) Installing an FE/GE Fiber Optic Cable for Cascading	34
1.8.8.4 (Optional) Installing an FE/GE Ethernet Cable for Cascading	36
1.8.9 Closing the Maintenance Cavity Covers.....	37
1.8.10 Adjusting Installation Angles	39
1.9 Checking the Hardware Installation.....	40

1.10 Performing a Power-On Check	41
1.11 References.....	42
1.11.1 SN Collection Template	42
1.11.2 Assembling a Tool-less Female Connector (Pressfit Type) and a Power Cable	43
1.11.3 Assembling a Shielded RJ45 Connector and an Ethernet Cable	46

1 BTS3911E Installation Guide

Introduction

This document describes how to install a BTS3911E in different scenarios and provides the hardware installation checklist as a reference.

Product Version

The following table lists the product version to which this document applies.

Product Name	Product Version
BTS3911E	V100R011C00

Intended Audience

This document is intended for:

- BTS3911E installation engineers
- System engineers
- Site maintenance engineers

Organization

1.1 Changes in BTS3911E Installation Guide

This section describes the changes in *BTS3911E Hardware Description*.

1.2 Installation Preparations

This section describes the preparations for installation. Before starting the installation, you must get the installation environment ready, obtain the required reference documents, tools, and instruments, and familiarize yourself with the skills required.

1.3 Unpacking Inspection

This section describes how to unpack and check the delivered materials to ensure that all the materials are included and intact.

1.4 Obtaining the SN

This section describes how to obtain the serial number (SN) of a BTS3911E. Before installing the BTS3911E, record its SN for future use during commissioning.

1.5 Installation Process

This section describes the process for installing a BTS3911E. The process includes:

- Installing a BTS3911E
- Installing cables
- Checking the hardware installation
- Performing a power-on check

1.7 Installing a BTS3911E

This section describes the procedure and precautions for installing a BTS3911E.

1.8 Installing Cables

This section describes the procedure and precautions for installing cables.

1.9 Checking the Hardware Installation

This section describes how to check the hardware installation after a BTS3911E is installed.

1.10 Performing a Power-On Check

This section describes the procedure for performing a power-on check on a BTS3911E.

1.11 References

This section describes reference information and common operations involved during installation.

1.1 Changes in BTS3911E Installation Guide

This section describes the changes in *BTS3911E Hardware Description*.

Draft A (2015-07-30)

This is a draft.

1.2 Installation Preparations

This section describes the preparations for installation. Before starting the installation, you must get the installation environment ready, obtain the required reference documents, tools, and instruments, and familiarize yourself with the skills required.

1.2.1 Installation Environment

Before starting the installation, ensure that the power supply equipment, transmission equipment, and related matching equipment are ready.

Precautions for Site Selection

- Do not install a BTS3911E near an interference source, such as a broadcast and television tower, high and low-voltage substation, high-voltage tower, high-power radio transmitter, and radar station.
- For the sake of surge protection, the mounting height of a BTS3911E should not be greater than 10 m. Do not install a BTS3911E along a highway or railway or on the mountain top, tower, standalone pole in a suburban area or open field, or standalone rooftop in a non-urban area.

Requirements for the Upper-level Circuit Breaker

Type C upper-level AC circuit breakers or slow-blow fuses must be used for power cables. The maximum current must not exceed 16 A. Table 1-1 describes the recommended specifications.

Table 1-1 Requirements for the upper-level circuit breaker

Input Voltage Type	Current of the Upper-level AC Circuit Breakers (or Fuses)
220 V AC single-phase or 110 V AC dual-live-wire	3 A to 4 A
110 V AC single-phase	5 A to 6 A

Requirements for Surge Protection and Grounding

Huawei by default uses a three-core power cable to connect a BTS3911E and external power supply equipment. The power supply side must ensure that the PE wire of the three-core power cable can be properly grounded. In outdoor installation scenarios or outdoor cabling scenarios, PGND cables must be used to guarantee the surge protection and grounding for the ground terminals of the mounting kits.



1.2.2 Reference Documents











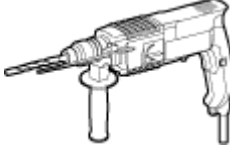







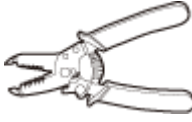
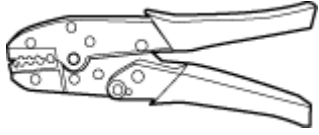
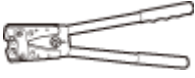

This section describes reference documents required for installation.

- Before starting the installation, you must be familiar with the following reference documents:
 - Safety Information
 - BTS3911E Hardware Description
- During the installation, you must be familiar with *Installation Reference*.

1.2.3 Tools and Instruments

Before starting the installation, prepare the following tools and instruments.

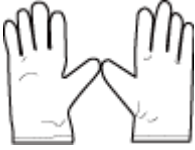
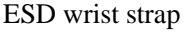
Marker (diameter ≤ 10 mm) 	Hammer drill (Ø8, Ø12, Ø14, or Ø16 bore)	Rubber mallet 
---	--	--

		
<p>Phillips screwdriver (M3 to M6, length \leq 200 m)</p>  <p>Flat-head screwdriver (M3 to M6)</p> 	<p>Torque screwdriver</p>  <p>Phillips (M3 to M8)</p>  <p>Flat-head (M3 to M8)</p> 	<p>Diagonal pliers</p> 
<p>Cable cutter</p> 	<p>Wire stripper</p> 	<p>COAX crimping tool</p> 
<p>Crimping tool for power cables</p> 	<p>Utility knife</p> 	<p>Heat gun</p> 
<p>Combination wrench (bore: 17 mm, 19 mm, or 21 mm)</p> 	<p>Adjustable wrench (bore \geq 32 mm)</p>  <p>Adjustable wrench (bore \leq 19 mm)</p> 	<p>Torque wrench (bore: 17 mm, 19 mm, or 21 mm)</p>  <p>Torque wrench (30 N m to 50 N m)</p> 
<p>Socket wrench (M10, M12)</p> 	<p>Level</p> 	<p>Measuring tape</p> 
<p>ESD gloves</p>  <p>ESD wrist strap</p> 	<p>Vacuum cleaner</p> 	<p>Multimeter</p> 

		
<p>RJ11 crimping tool</p> 	-	-

1.2.4 Skills and Requirements for Installation Personnel

Installation personnel must be qualified, trained, and familiar with correct operation methods and safety precautions before performing any operations.

Before starting the installation, pay attention to the following items:

- The customer's technical engineers must be trained by Huawei and be familiar with the proper installation and engineering methods.
- The number of required installation personnel depends on the engineering schedule and installation environment. Generally, three to five installation personnel are necessary.

1.2.5 Installation Scenarios

A BTS3911E can be installed on a pole or a wall.

Pole-mounted Installation

A BTS3911E can be installed on a pole with a diameter of 60 mm to 381 mm.

Figure 1-1 illustrates a pole-mounted BTS3911E.

Figure 1-1 Pole-mounted installation

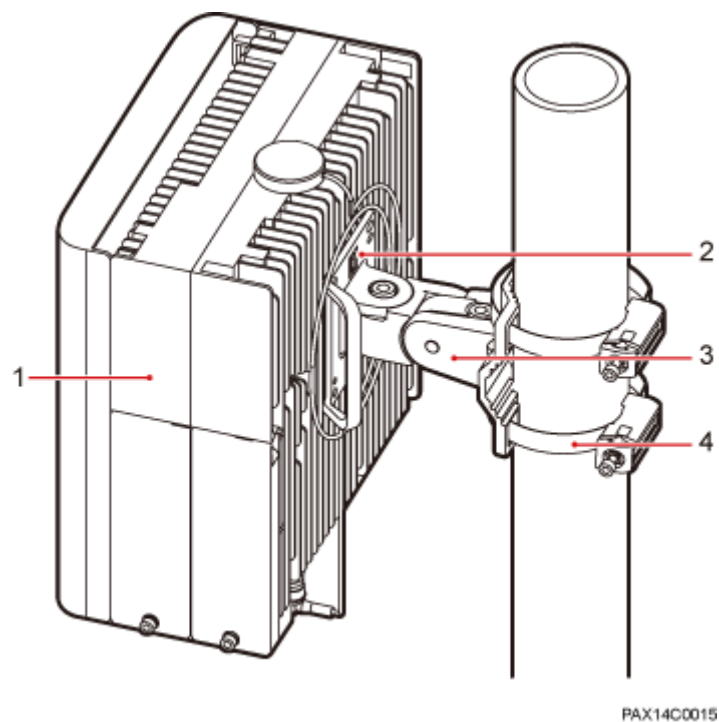

(1) BTS3911E	(2) Angle adjusting attachment plate	(3) Angle adjusting mounting bracket	(4) Steel belt
--------------	--------------------------------------	--------------------------------------	----------------

Wall-mounted Installation

In wall-mounted installation scenarios, note the following:

- The wall on which a single BTS3911E is to be installed can carry a weight of 60 kg without damage.
- Expansion bolts must be torqued to 28 N m to ensure the bolts work properly without causing cracks on the wall.

Figure 1-2 illustrates a wall-mounted BTS3911E.

Figure 1-2 Wall-mounted installation

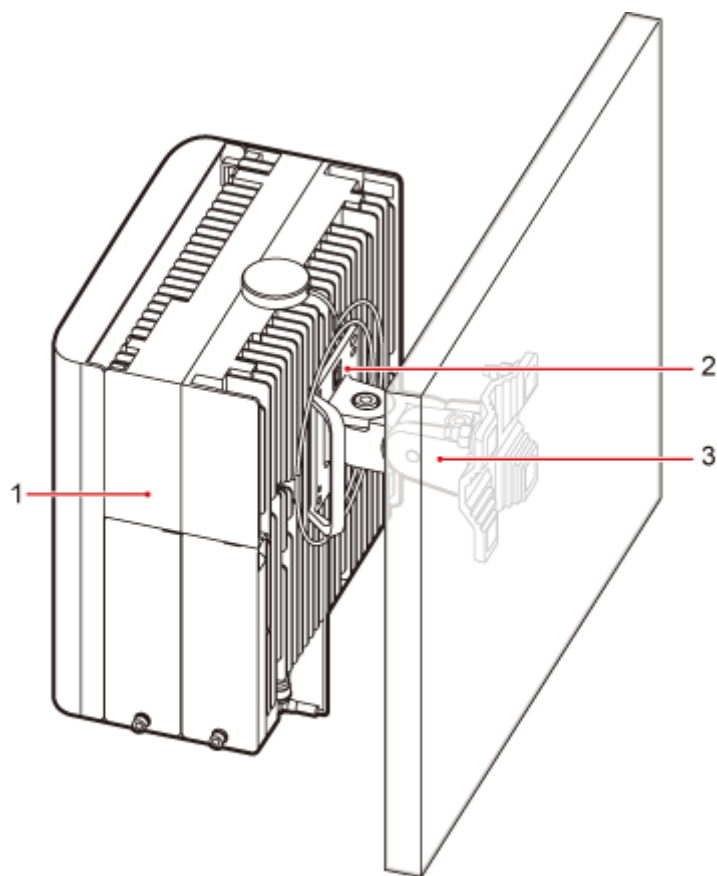

PAX14C0017

(1) BTS3911E	(2) Angle adjusting attachment plate	(3) Angle adjusting mounting bracket	-
--------------	--------------------------------------	--------------------------------------	---

1.2.6 Installation Clearance Requirements

This section describes the clearance requirements for installing a BTS3911E on a pole or wall.

Figure 1-3 shows the recommended installation clearances around a BTS3911E.

Figure 1-3 Recommended installation clearances around a BTS3911E

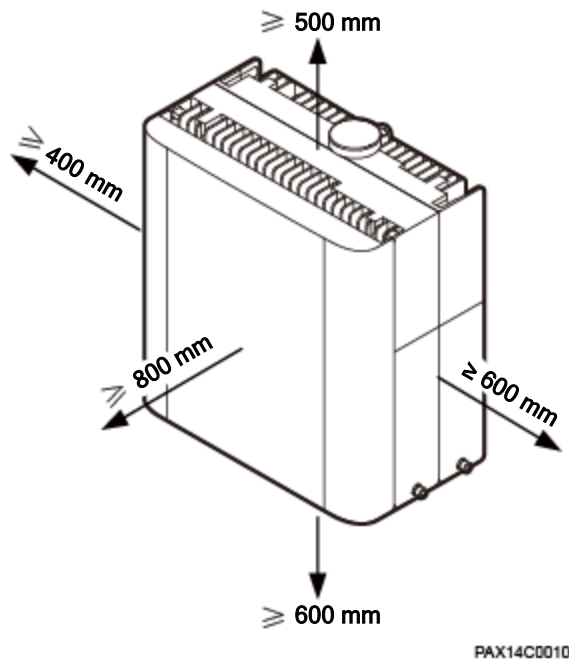
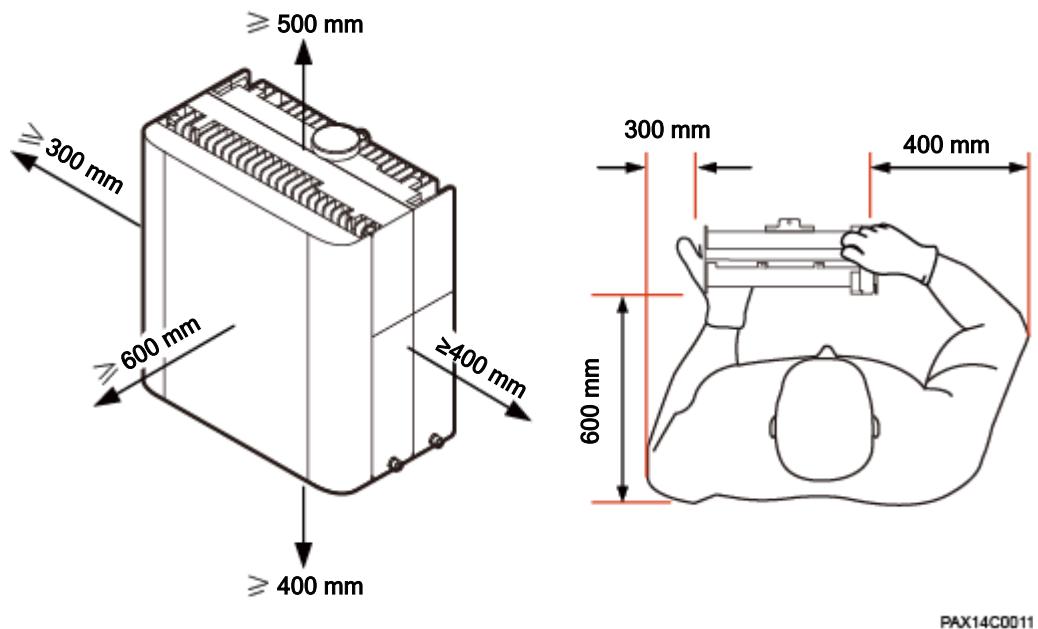

Figure 1-4 shows the minimum installation clearances around a BTS3911E.

Figure 1-4 Minimum installation clearances around a BTS3911E



1.3 Unpacking Inspection

This section describes how to unpack and check the delivered materials to ensure that all the materials are included and intact.

Prerequisites



CAUTION

After a BTS3911E is unpacked, power it on within 24 hours. If the BTS3911E is powered off for maintenance, restore power to it within 24 hours.

Context



NOTE

When transporting, moving, or installing the equipment, components, or parts, you must:

- Prevent them from colliding with doors, walls, shelves, or other objects.
- Wear clean gloves, and avoid touching the equipment, components, or parts with bare hands, sweat-soaked gloves, or dirty gloves.

Procedure

Step 1 Check the total number of articles in each packing case against the packing list.

If...	Then...
The total number tallies with the packing list	Go to Step 2.
The total number does not tally with the packing list	Find out the cause and contact the local Huawei office.

Step 2 Check the exterior of each packing case.

If...	Then...
The outer packing is intact	Go to Step 3.
The packing case is severely damaged or soaked	Find out the cause and contact the local Huawei office.

Step 3 Check the type and quantity of the equipment in each packing case against the packing list.

If...	Then...
The type and quantity tallies with the packing list	Sign the <i>Packing List</i> with the customer.
There is any shipment shortage or wrong shipment	Fill in and submit the <i>Cargo Shortage and Mishandling Report</i> .
There is damaged shipment	Fill in and submit the <i>Article Replacement Report</i> .



CAUTION

To protect the equipment from damage, keep the unpacked equipment and packing materials indoors. To help find out the cause of any damage in the future, take photos of the storeroom, rusted or eroded equipment, packing cases, and packing materials, and then file the photos.

----End

1.4 Obtaining the SN

This section describes how to obtain the serial number (SN) of a BTS3911E. Before installing the BTS3911E, record its SN for future use during commissioning.

Context

The SN uniquely identifies a device and is required during commissioning. The SN label of a BTS3911E is attached to the surface of the BTS3911E.

Procedure

Step 1 Remove the backup SN label from the surface of the BTS3911E. See Figure 1-5.



NOTE

Before removing the backup SN label, photograph it.

Figure 1-5 Removing the SN label

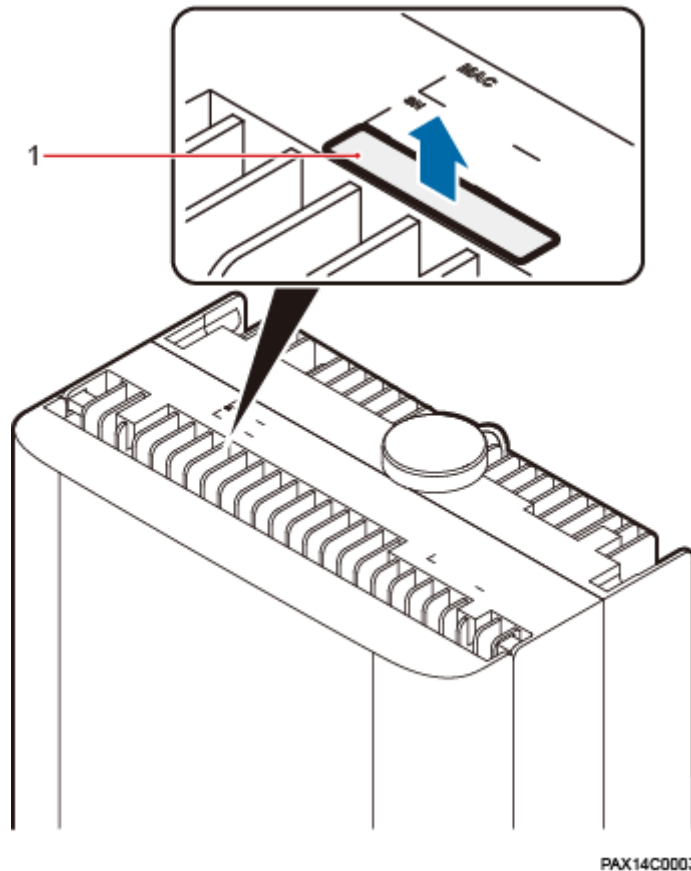

(1) Backup SN label	-
---------------------	---

Step 2 Record the SN by using the template described in section 1.11.1 SN Collection Template, and report it to the BTS3911E commissioning personnel.

----End

1.5 Installation Process

This section describes the process for installing a BTS3911E. The process includes:

- Installing a BTS3911E
- Installing cables
- Checking the hardware installation
- Performing a power-on check

Figure 1-6 outlines the process for installing a BTS3911E.

Figure 1-6 Process for installing a BTS3911E

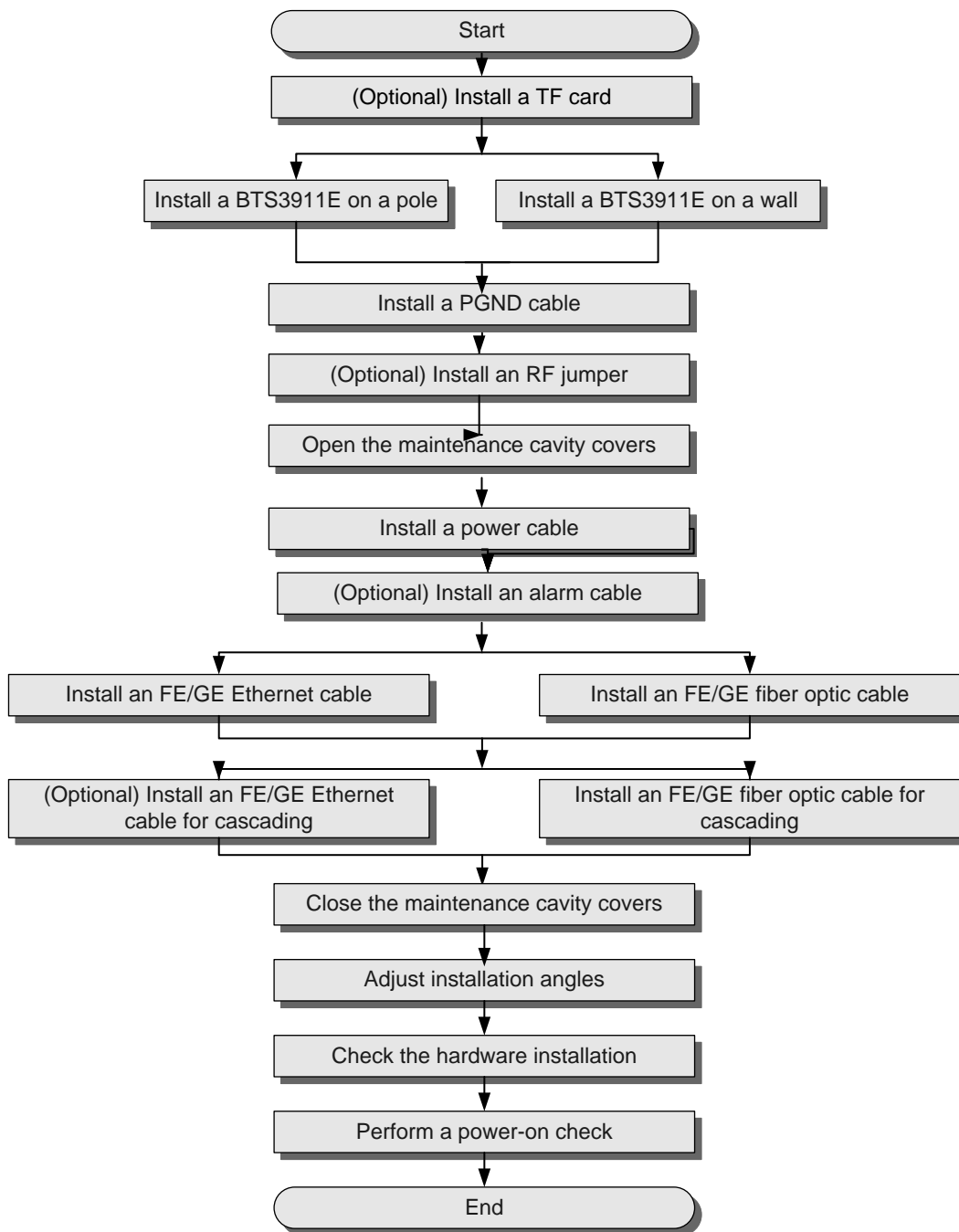

IPP02C0007

1.6 (Optional) Installing a TF Card

This section describes the procedure and precautions for installing a TF card. This operation is required if the TF card is to be used for BTS3911E deployment.

Prerequisites

The TF card to be installed must be preconfigured with software and (or) configuration data. For details, see *BTS3911E Commissioning Guide*.

Procedure

- Step 1** Use a Phillips screwdriver to loosen the captive screw on the maintenance cavity cover on the bottom of the BTS3911E. Open the maintenance cavity cover. See **a** and **b** in Figure 1-7.
- Step 2** Insert the TF card into the anchor slot, as indicated by the direction on the maintenance cavity cover. See **c** in Figure 1-7.

Figure 1-7 Installing a TF card

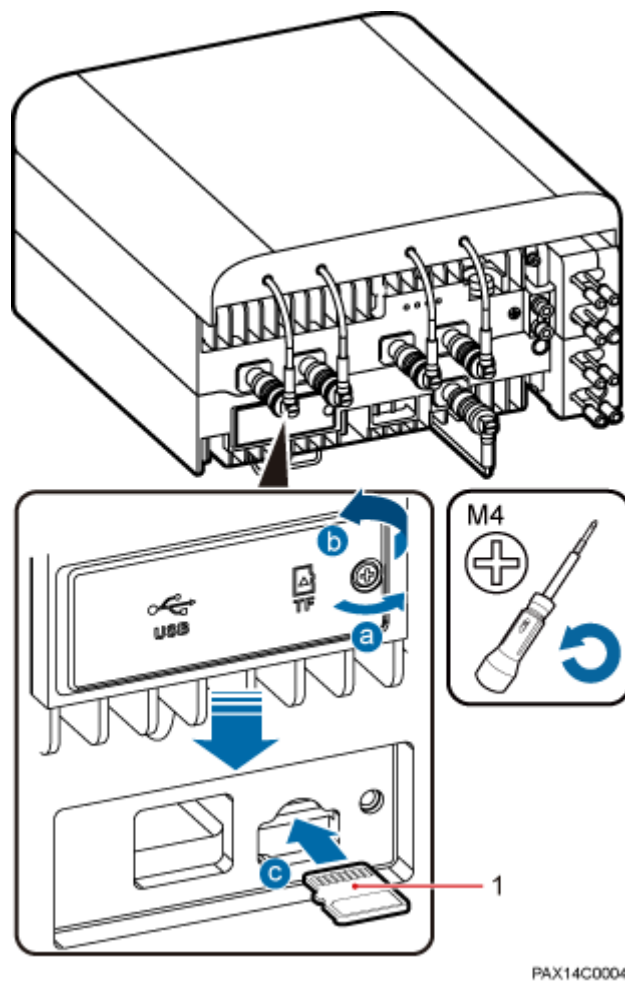

PAX14C0004

(1) TF card	-
-------------	---

- Step 3** Close the maintenance cavity cover, and use the Phillips screwdriver to torque the screw to 1.4 N m.

----End

1.7 Installing a BTS3911E

This section describes the procedure and precautions for installing a BTS3911E.

1.7.1 Mounting Kits

This section describes the kits for mounting a BTS3911E on a pole or wall.

Angle Adjusting Attachment Plate

Figure 1-8 shows the appearance of an angle adjusting attachment plate.

Figure 1-8 Angle adjusting attachment plate

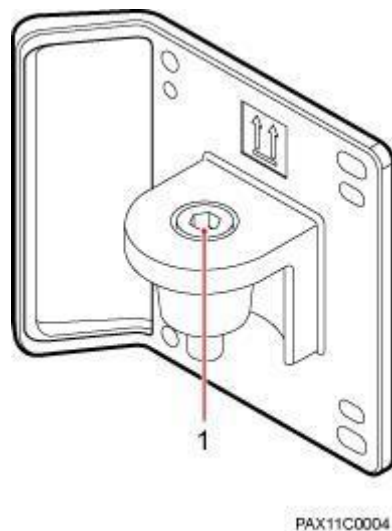

(1) Hole for a horizontal angle adjusting screw	-
---	---

Angle Adjusting Mounting Bracket

Figure 1-9 shows the appearance of an angle adjusting mounting bracket.

Figure 1-9 Angle adjusting mounting bracket

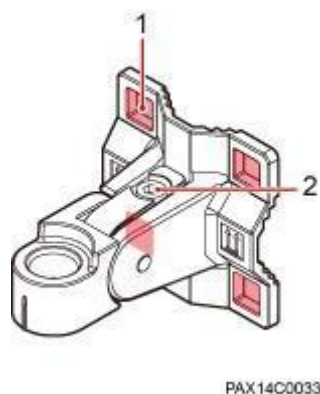

(1) Mounting hole for a steel belt or an expansion bolt	(2) Hole for a vertical angle adjusting screw
---	---

1.7.2 Installing a BTS3911E on a Pole

This section describes the procedure and precautions for installing a BTS3911E on a pole.

Procedure

- Step 1** Route two steel belts separately through the up and down mounting holes on the angle adjusting mounting bracket, but do not route the steel belts through the buckles. See Figure 1-10.

Figure 1-10 Routing steel belts

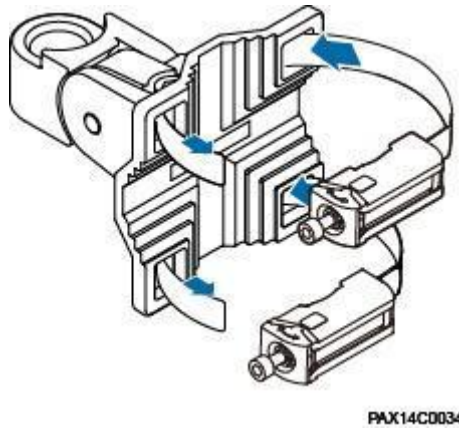

- Step 2** Fit the angle adjusting mounting bracket onto the target pole as follows: Open the mounting base according to the arrow direction, route the steel belts through the base, tighten the steel belts, and use an M6 hex key screwdriver to torque the screws to 7 N·m. See Figure 1-11.



NOTE

Redundant steel belts must be bound.

Figure 1-11 Tightening steel belts

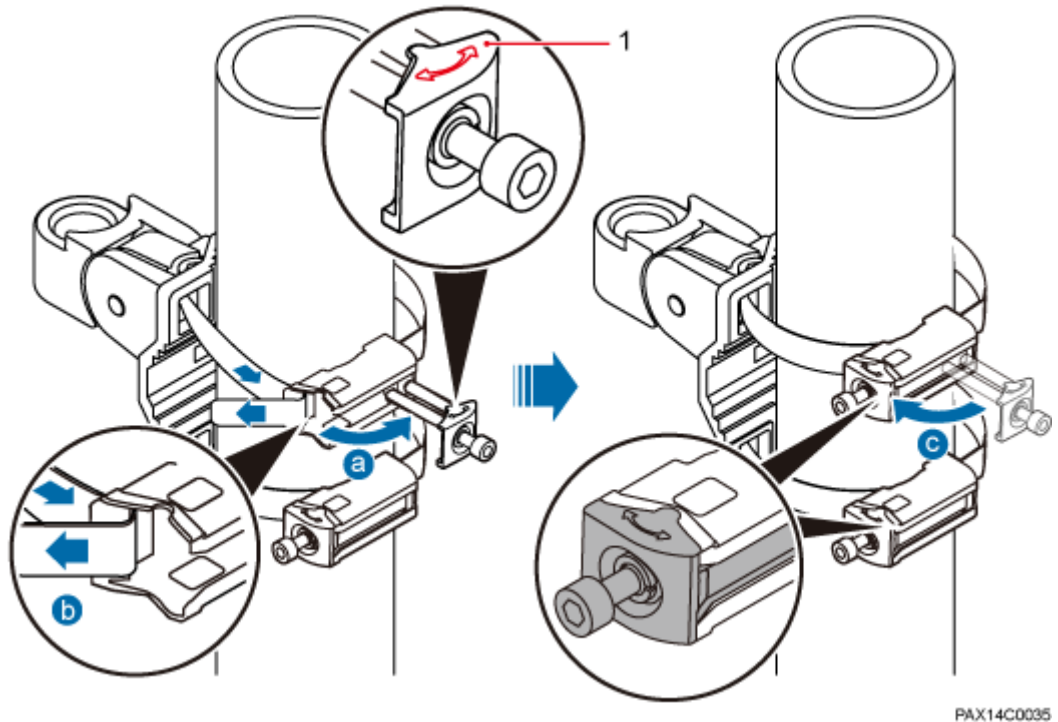

PAX14C0035

(1) Mounting base of steel belts	-
----------------------------------	---

Step 3 Fit the BTS3911E onto the angle adjusting mounting bracket, and use an M10 hex key screwdriver to torque the angle adjusting screw to 28 N·m. See Figure 1-12.

Figure 1-12 Fitting a BTS3911E onto an angle adjusting mounting bracket

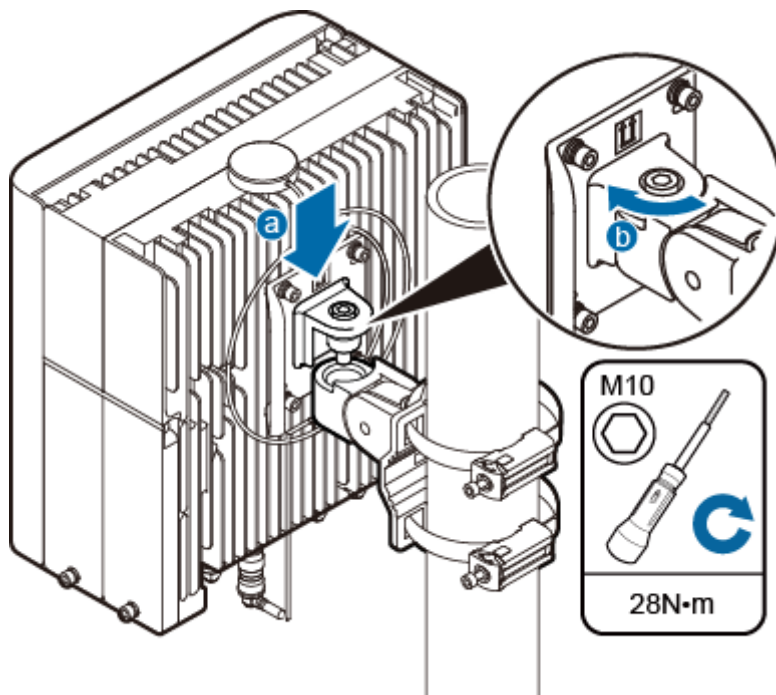

----End

1.7.3 Installing a BTS3911E on a Wall

This section describes the procedure and precautions for installing a BTS3911E on a wall.

Procedure

- Step 1** Place the angle adjusting mounting bracket against the wall, use a level to verify that the mounting bracket is placed horizontally, and use a marker to mark anchor points. See Figure 1-13.

Figure 1-13 Marking anchor points

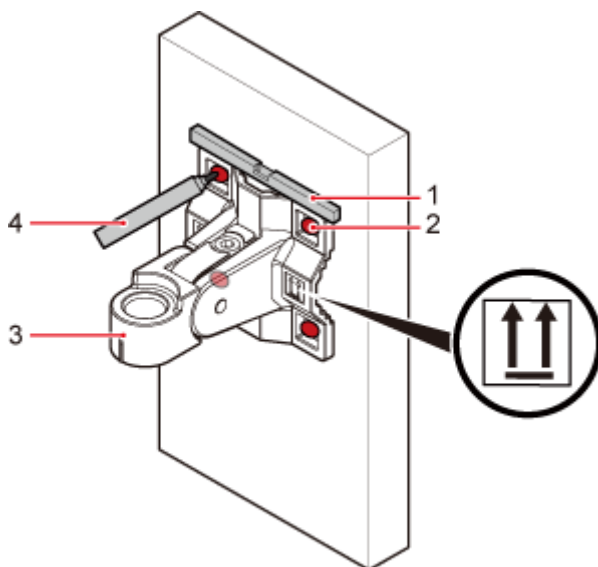

PAX14C0018

(1) Level	(2) Mounting holes	(3) Angle adjusting mounting bracket	(4) Marker
-----------	--------------------	--------------------------------------	------------



CAUTION

To prevent inhalation or eye contact with dust, take adequate preventive measures when drilling holes.

- Step 2** Drill holes at the anchor points, and install expansion bolts. See Figure 1-14.

Figure 1-14 Drilling holes and installing expansion bolts

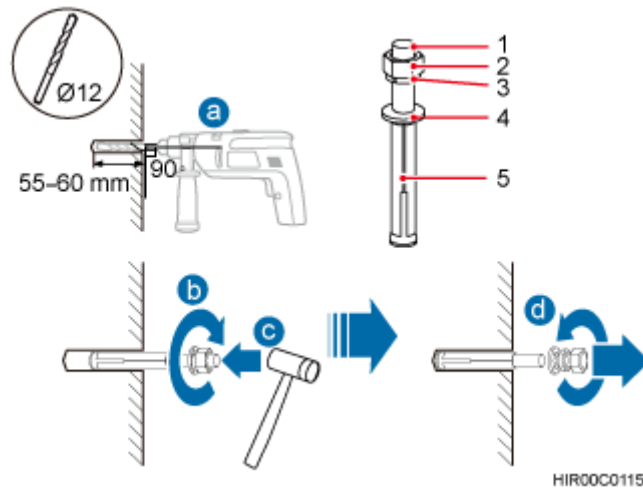

(1) M10x80 expansion bolt	(2) Nut	(3) Spring washer	(4) Flat washer	(5) Expansion sleeve
---------------------------	---------	-------------------	-----------------	----------------------

- Use a hammer drill with $\Phi 12$ bore to drill holes vertically at the marked anchor points. Ensure that the holes have the same depth ranging from 55 mm to 60 mm.
- Use a vacuum cleaner to clear the dust from inside and around the holes, and measure the inter-hole spacing. If the spacing is too wide or too narrow, relocate positions and drill holes again.
- Partially tighten an expansion bolt and vertically insert it into each hole.
- Use a rubber mallet to hit the expansion bolts until the entire expansion sleeve is in each hole.
- Remove the M10x80 bolt, nut, spring washer, and flat washer in sequence.



CAUTION

- Level the front of each expansion sleeve with the wall after disassembling an expansion bolt. Otherwise, the mounting bracket will not be securely installed on the wall.
- Do not hammer the swell fixtures entirely into the wall. Instead, leave 8 mm to 12 mm of each swell fixture outside the wall.

Step 3 Fit the angle adjusting mounting bracket onto the wall through the four expansion bolts, and use an M10 socket wrench to torque the four expansion bolts to 28 N m. See Figure 1-15.

Figure 1-15 Fitting an angle adjusting mounting bracket onto the wall

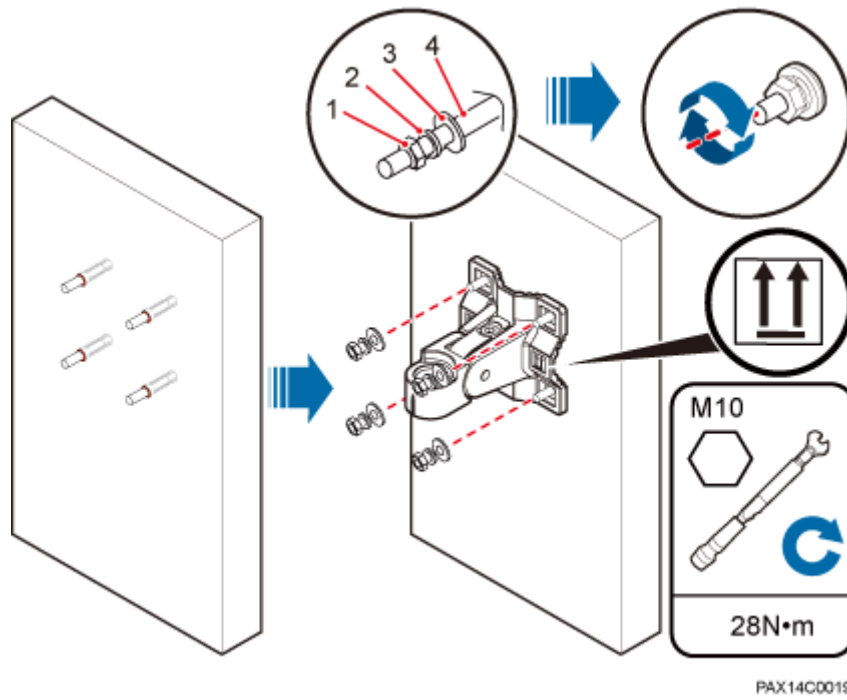

(1) Nut	(2) Spring washer	(3) Flat washer	(4) Swell fixture
---------	-------------------	-----------------	-------------------

Step 4 Fit the BTS3911E onto the angle adjusting mounting bracket, and use an M10 hex key screwdriver to torque the angle adjusting screw to 28 N m. See Figure 1-16.

Figure 1-16 Fitting a BTS3911E onto the angle adjusting mounting bracket

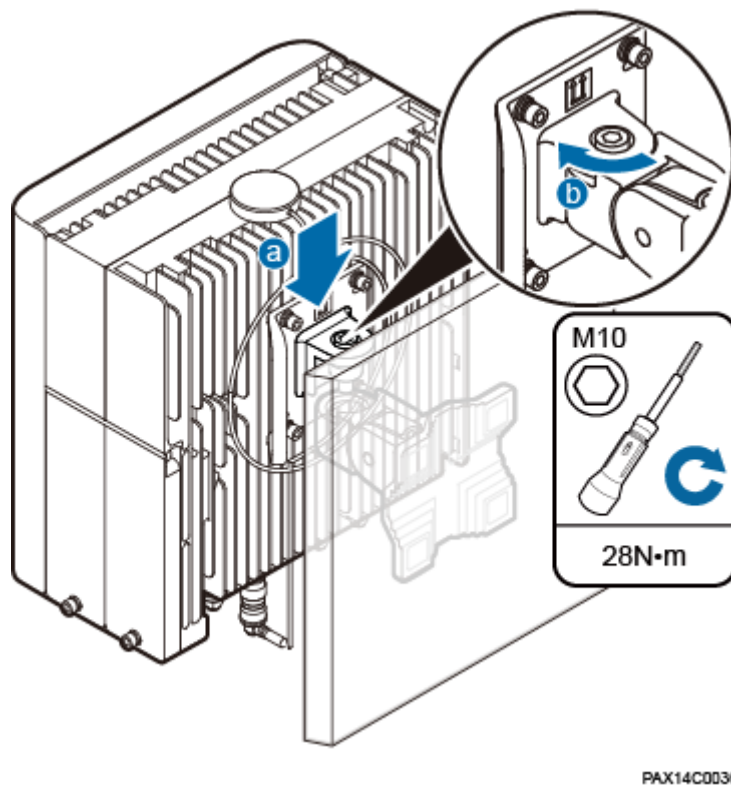

----End

1.8 Installing Cables

This section describes the procedure and precautions for installing cables.

1.8.1 Cabling Requirements

Cables must be routed according to the specified cabling requirements to prevent interference between signals.

 **NOTE**

If a cable listed below is not required, skip the cabling requirements of the cable.

General Cabling Requirements

The bending radius of the cables must meet the following specifications:

- The bending radius of a 7/8" feeder must be greater than 250 mm, and the bending radius of a 5/4" feeder must be greater than 380 mm.
- The bending radius of a 1/4" jumper must be greater than 35 mm. The bending radius of a super-flexible 1/2" jumper must be greater than 50 mm, and the bending radius of an ordinary 1/2" jumper must be greater than 127 mm.
- The bending radius of a power cable or PGND cable must be at least five times its diameter.

- The bending radius of a fiber optic cable must be at least 20 times its diameter.
- The bending radius of a signal cable must be at least five times its diameter.

The cables must be bound as follows:

- Cables must be bound tightly and neatly. The sheaths of cables must not be damaged.
- Cable ties must face the same direction, and those at the same horizontal line must be in a straight line. The excess of cable ties must be cut off.
- Labels or nameplates must be attached to the cables after they are installed.

The cables must be routed as follows:

- Cables of different types must be routed separately in an untangled and orderly fashion.
- Cables of different types must be parallel to each other or separated by using dedicated separators.

Special Cabling Requirements

Power cables must be routed as follows:

- Multiple power cables must be bound when routed.
- Power cables must be installed in the positions specified in engineering design documents.
- If the length of power cables is insufficient, the power cables must be replaced instead of adding connectors or soldering joints to lengthen the cables.

PGND cables must be routed as follows:

- PGND cables for a BTS3911E must be connected to the same ground bar.
- PGND cables must be buried in the ground or routed indoors. They must not be routed overhead before they are led into the equipment room.
- The exterior of a coaxial wire and the shield layer of a shielded cable must have proper electrical contact with the metal surface of the equipment to which they are connected.
- PGND cables and signal cables must be bound separately in an untangled and orderly fashion. A certain distance must be reserved between them to prevent mutual interference.
- Fuses or switches must not be installed on PGND cables.
- Other devices must not be used for electrical connections of PGND cables.
- All the metal parts in the housing of the BTS3911E must be reliably connected to the ground terminal.

Signal cables must be routed as follows:

- Signal cables must not cross power cables, PGND cables, or RF cables when routed. If transmission cables are routed parallel to power cables, PGND cables, or RF cables, the spacing between them must be greater than 30 mm.
- Signal cables must be routed straightly and bound neatly with cable ties.
- Sufficient slack must be provided in signal cables at turns.

Fiber optic cables must be routed as follows:

- A minimum of three qualified and trained personnel are required to route fiber optic cables.

- The operating temperature of fiber optic cables ranges from -40°C to +60°C. If the current temperature is out of the range, additional protection measures must be taken or the cable routing must be changed.
- Cables must be routed in an untangled and orderly fashion.
- Fiber optic cables must not be bound at turns.
- Fiber optic cables cannot be stretched with too much force or stepped on, and they must be far away from sharp objects. Heavy objects cannot be placed on fiber optic cables.
- When fiber optic cables are routed, the excess of the cables must be coiled around special devices, such as a fiber coiler.
- Fiber optic cables must be coiled gently and must not be bent in a forcible manner.
- Vacant optical connectors must be covered with dustproof caps.
- Fiber optic cables cannot be squeezed by a cabinet door when routed through a cabinet.
- When routed on the tower platform, the fiber optic cables must be laid out along the guardrail within the shortest distance.
- When routed close to a device on the tower, the fiber optic cables must be secured to the guard rail or pole with cable clips. The BTS3911E must not be far away from the position for securing the fiber optic cables.
- The excess of the fiber optic cables must be coiled and secured on the tower.

1.8.2 Cable Connections

Figure 1-17 shows the cable connections for a BTS3911E.

Figure 1-17 BTS3911E cable connections

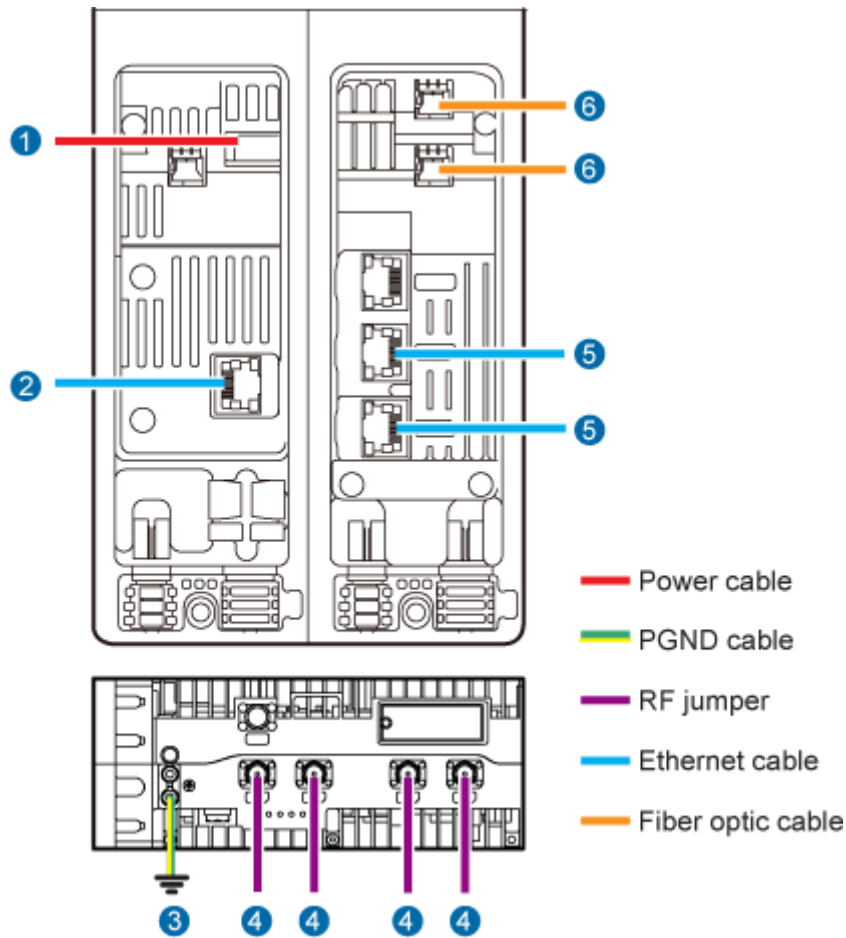

PAX14C0037

(1) External power supply equipment	(2) External monitored equipment	(3) External ground bar	(4) External antenna system
(5) External transmission equipment or cascaded BTS3911E	(6) External transmission equipment or cascaded BTS3911E	-	-

1.8.3 Installing a PGND Cable

This section describes the procedure and precautions for installing a PGND cable.

Context

The length of a PGND cable must not exceed 30 m. When the required PGND cable is longer than 30 m, deploy the ground bar nearer the BTS3911E. Table 1-2 lists the specifications of a PGND cable.

Table 1-2 PGND cable specifications

Cable	One End	The Other End	Color
PGND cable	OT terminal (M6, 6 mm ²)	OT terminal (M8, 6 mm ²)	Yellowish green or green

Procedure

Step 1 Make a PGND cable for the BTS3911E.

- Cut the cable to the required length based on the actual cable route.
- Add an OT terminal to each end of the PGND cable by following instructions provided in section "Assembling the OT Terminal and the Power Cable" of *Installation Reference*.

Step 2 Install the PGND cable.

Connect the M6 OT terminal at one end of the PGND cable to the ground terminal at the BTS3911E bottom and the M8 OT terminal at the other end to the external ground bar, as shown in Figure 1-18.

Figure 1-18 Installing a PGND cable

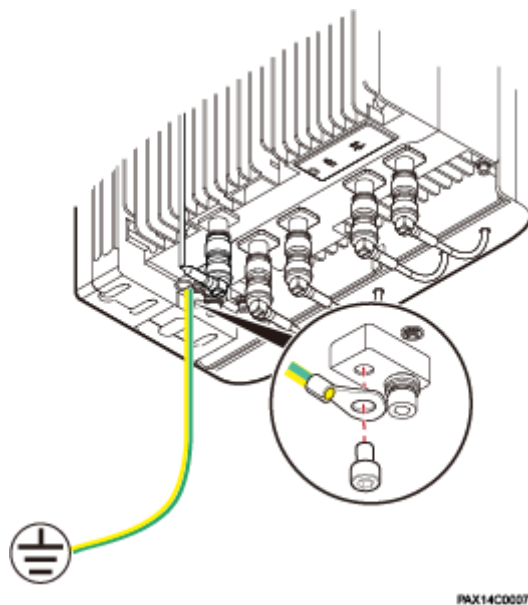

NOTE

When installing the PGND cable, crimp OT terminals in correct positions. See Figure 1-19.

Figure 1-19 Crimping an OT terminal

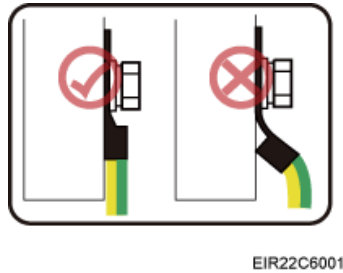

----End

Follow-up Procedure

Route the cable by following instructions provided in section 1.8.1 "Cabling Requirements" and then use cable ties to bind the cable.

1.8.4 (Optional) Installing an RF Jumper

This section describes how to install an RF jumper for a BTS3911E. This operation is required when the BTS3911E uses an external antenna.

Context



NOTE

The cable route depends on actual requirements.

Procedure

- Step 1** Connect the Smart-type N male connector at one end of the RF jumper to the RF port on the BTS3911E.

Hold the metal part of the Smart-type N male connector and push the connector upwards. A slight crack will be heard when the connector is properly installed. See Figure 1-20.

Figure 1-20 Installing an RF jumper

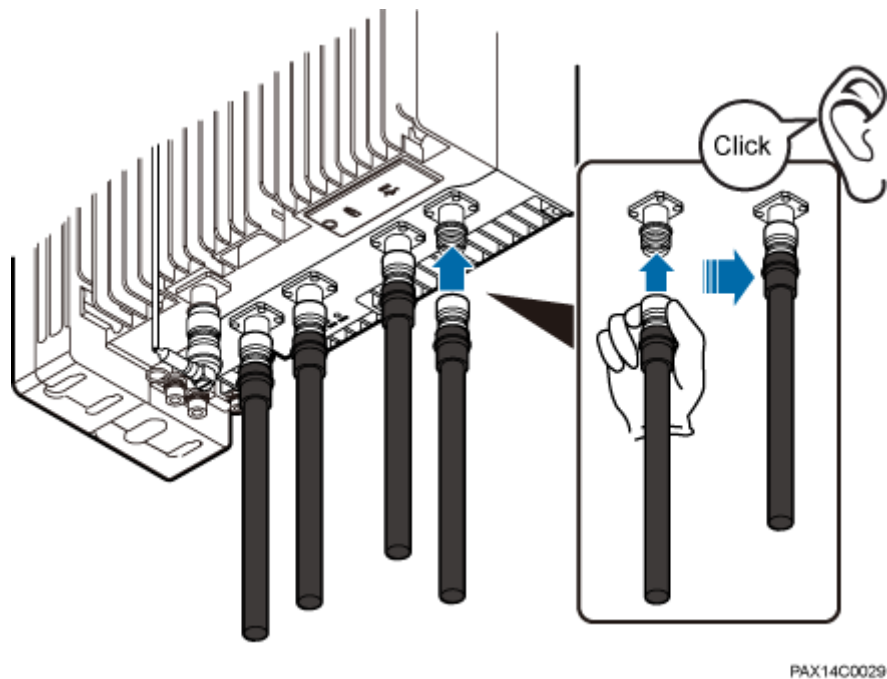

Step 2 Connect the other end of the RF jumper to the external antenna system.

----End

Follow-up Procedure

Route the cable by following instructions provided in section 1.8.1 "Cabling Requirements" and then use cable ties to bind the cable.

1.8.5 Opening the Maintenance Cavity Covers

This section describes the procedure and precautions for opening the maintenance cavity covers of a BTS3911E.

Procedure

Step 1 Adjust the angles of the BTS3911E. See Figure 1-21.

- Use an M10 hex key screwdriver to loosen the horizontal angle adjusting screw on the top of the angle adjusting attachment plate. Adjust the horizontal angle of the BTS3911E within the range of -18° to $+18^{\circ}$.
- Use the M10 hex key screwdriver to loosen the vertical angle adjusting screw on the top of the angle adjusting mounting bracket. Adjust the vertical angle of the BTS3911E within the range of -30° to $+30^{\circ}$.

Figure 1-21 Adjusting the angle of a BTS3911E

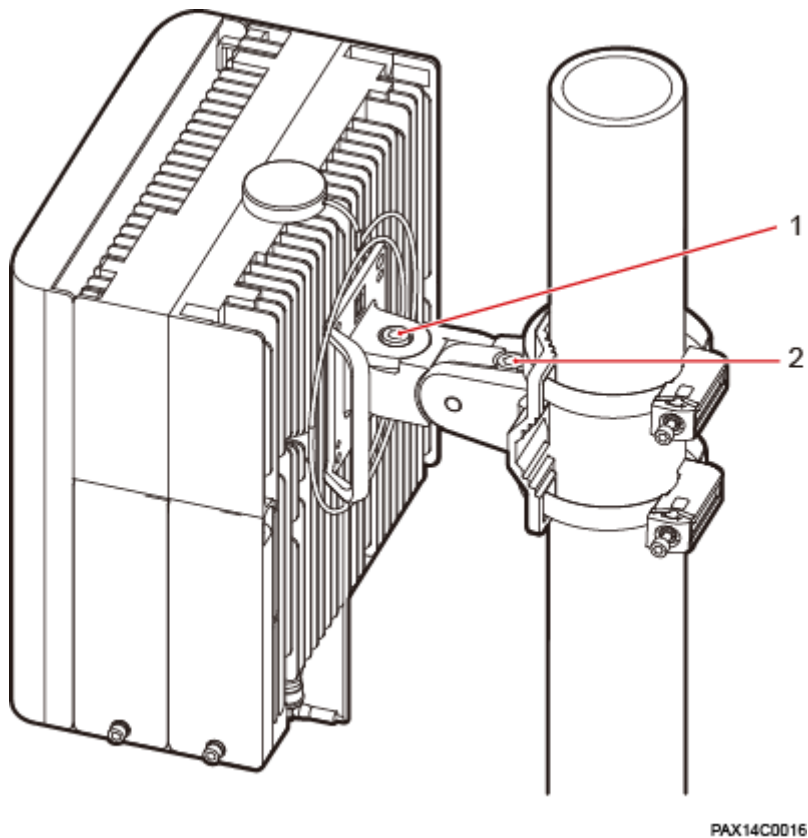

(1) Horizontal angle adjusting screw	(2) Vertical angle adjusting screw
--------------------------------------	------------------------------------

Step 2 Use an M6 hex key screwdriver to loosen the captive screw on both the maintenance cavity covers. Open the maintenance cavity covers.

Figure 1-22 shows the maintenance cavity structure.

Figure 1-22 Maintenance cavity structure

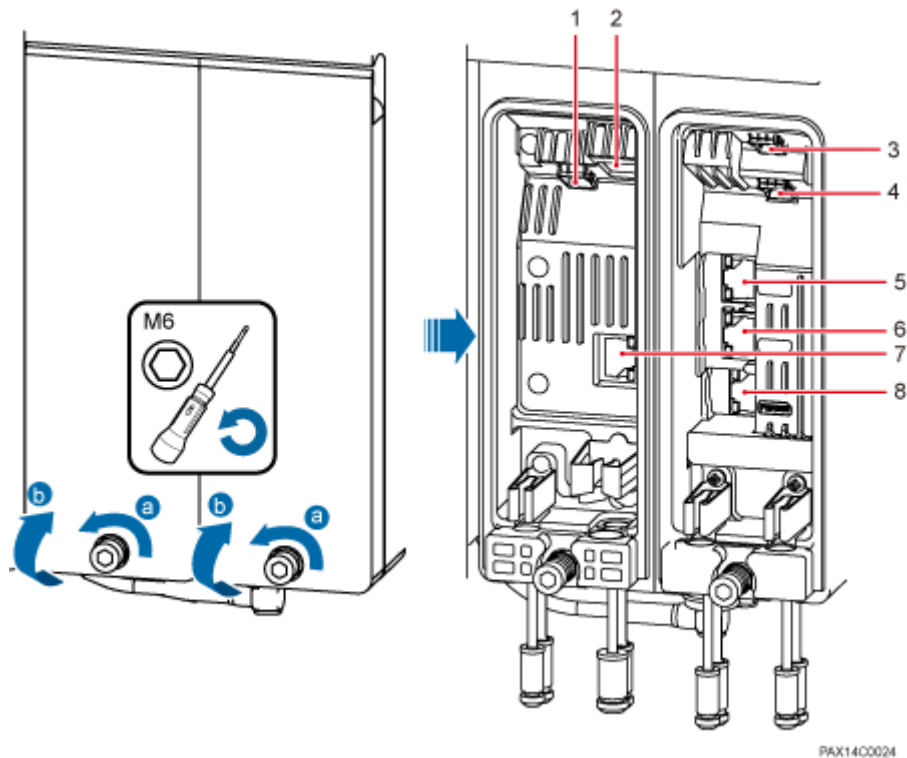

(1) CPRI	(2) PWR	(3) FE/GE3	(4) FE/GE2
(5) DBG	(6) FE/GE1	(7) EXT_ALM	(8) FE/GE0

NOTE

When routing cables from a maintenance cavity, observe the following:

- Route the power cable through an external cable hole.
- Route the other cables through internal cable holes preferentially.

Step 3 Remove the waterproof blocks for the cables to be installed.

----End

1.8.6 Installing a Power Cable

This section describes the procedure and precautions for installing a power cable for a BTS3911E. The power cable connects the BTS3911E and external power supply equipment.

Context

Table 1-3 lists the specifications of a power cable.

Table 1-3 Power cable specifications

Cable		Color	One End	The Other End	Remarks
Input power cable for a BTS3911E	L	Brown	Tool-less female connector (pressfit type)	Depends on the external power supply equipment.	Black jacket
	N	Blue			
	PE	Yellowish green			



NOTE

The color and structure of power cables vary with countries and regions. The power cables purchased locally must conform to the local standards.

Procedure

Step 1 Make a power cable.

- Cut the cable to a length suitable for the actual cable route.
- Add a cord end terminal to one end of the cable by following instructions provided in section 1.11.2 Assembling a Tool-less Female Connector (Pressfit Type) and a Power Cable. At the other end, add a terminal that matches the external power supply equipment.

Step 2 Installing the power cable. Connect the terminal of the power cable to the PWR port on the BTS3911E. See Figure 1-23.

Figure 1-23 Installing a power cable

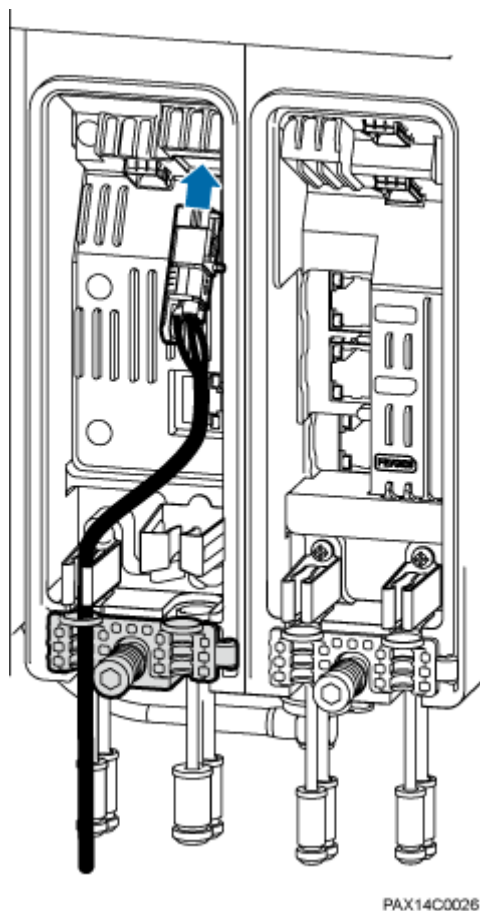

----End

Follow-up Procedure

Route the cable by following instructions provided in section 1.8.1 "Cabling Requirements" and then use cable ties to bind the cable.

1.8.7 Installing an Alarm Cable

This section describes the procedure and precautions for installing an alarm cable.

Procedure

Step 1 Make an alarm cable.

1. Add an RJ45 connector to one end of the alarm cable by following instructions provided in section 1.11.3 Assembling a Shielded RJ45 Connector and an Ethernet Cable.
2. Check whether the made RJ45 connector is qualified by following instructions in section "Checking the Appearance of Metal Contact Strips" of *Installation Reference*.
3. Repeat the preceding two steps to add an RJ45 connector to the other end of the alarm cable.

4. Test the continuity of each contact point of the cable and check that the cable is correctly and securely connected by following instructions in section "Testing the Connection of Assembled Cables" of *Installation Reference*.

Step 2 Connect one end of the alarm cable to the EXT_ALM port on the BTS3911E and the other end to the external monitored equipment. See Figure 1-24.

Figure 1-24 Installing an alarm cable

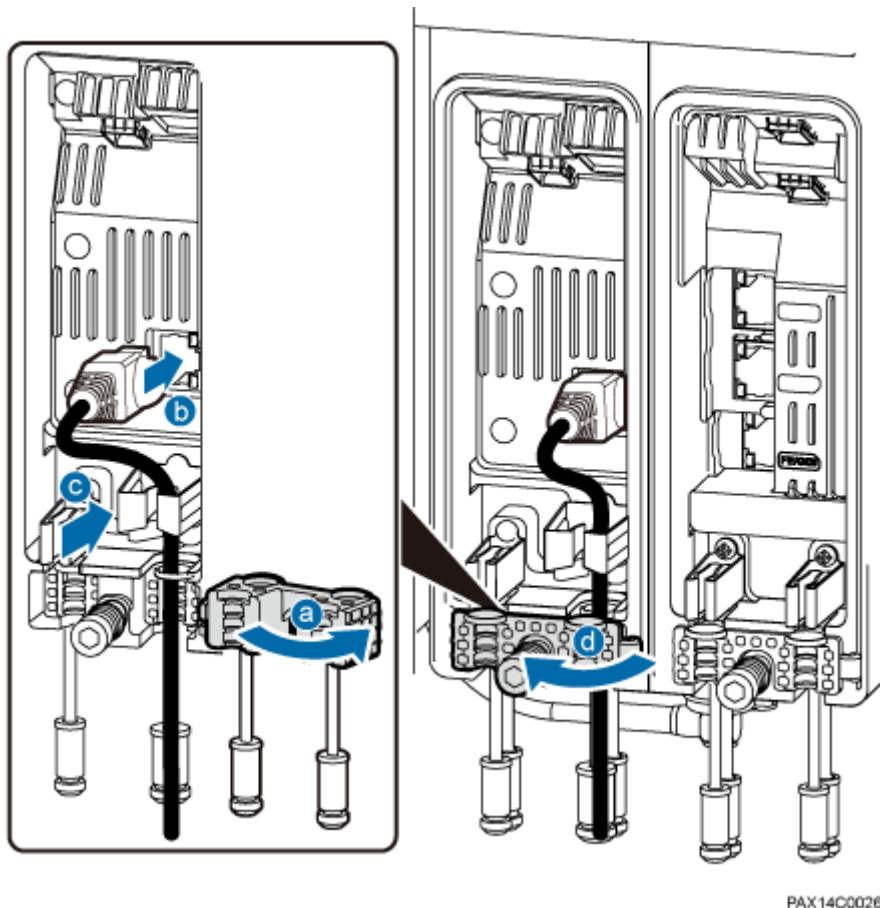

----End

Follow-up Procedure

Route the cable by following instructions provided in section 1.8.1 "Cabling Requirements" and then use cable ties to bind the cable.

1.8.8 Installing Transmission Cables

This section describes the procedure and precautions for installing transmission cables.

1.8.8.1 Installing an FE/GE Fiber Optic Cable

This section describes the procedure and precautions for installing an FE/GE fiber optic cable.

Context

- The single-mode optical modules to be installed must match the data rate at the optical ports.
- Do not twist, bend, stretch, or squeeze fiber optic cables during installation.
- Long-time exposure to the air causes performance exceptions on an optical module. Therefore, optical modules must be connected to fiber optic cables within 20 minutes after being unpacked.
- The cable route depends on actual requirements.
- One end of a fiber optic cable can be connected to the FE/GE2 or FE/GE3 port on the BTS3911E. Connection to the FE/GE2 port is preferred.

Procedure

- Step 1** Remove the dustproof cap from the FE/GE2 or FE/GE3 port. Keep the cap secure.
- Step 2** Insert an optical module into the FE/GE2 or FE/GE3 port, and remove the dustproof cap from the optical module.
- Step 3** Remove the dustproof cap from the optical fiber connector, tidy the optical fibers, and insert the DLC connector into the optical module. See Figure 1-25.

Figure 1-25 Installing a fiber optic cable

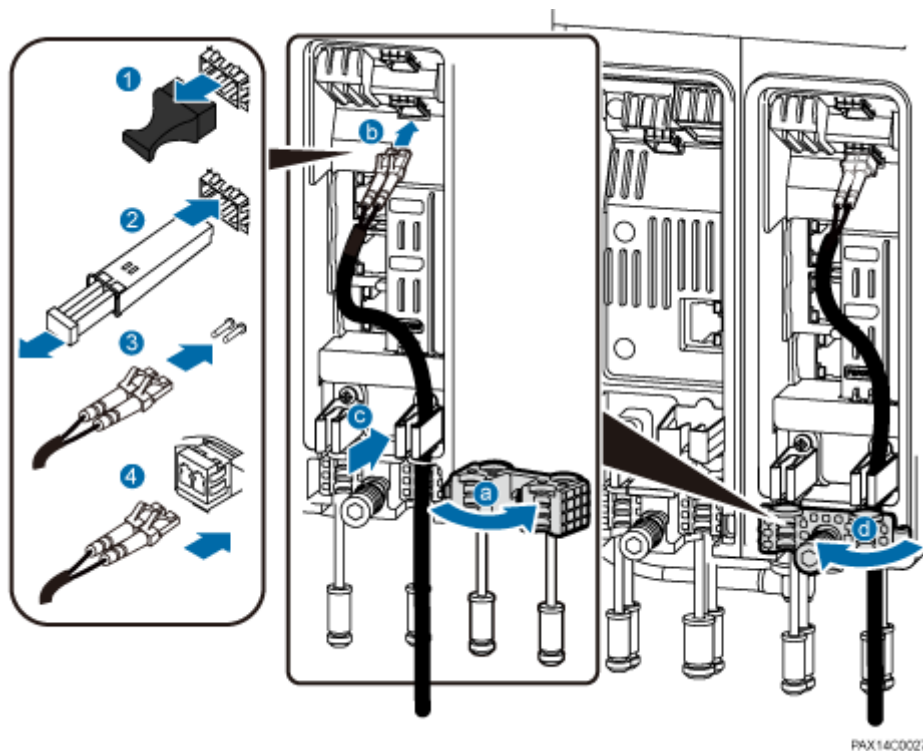

----End

Follow-up Procedure

Route the cable by following instructions provided in section 1.8.1 "Cabling Requirements" and then use cable ties to bind the cable.

1.8.8.2 Installing an FE/GE Ethernet Cable

This section describes the procedure and precautions for installing an FE/GE Ethernet cable.

Context

An FE/GE Ethernet cable must be a shielded straight-through cable.

One end of an FE/GE Ethernet cable can be connected to the FE/GE0 or FE/GE1 port on the BTS3911E. Connection to the FE/GE0 port is preferred.

Procedure

Step 1 Make an FE/GE Ethernet cable.

1. Add an RJ45 connector to one end of the FE/GE Ethernet cable by following instructions in section 1.11.3 Assembling a Shielded RJ45 Connector and an Ethernet Cable.
2. Check whether the made RJ45 connector is qualified by following instructions in section "Checking the Appearance of Metal Contact Strips" of *Installation Reference*.
3. Repeat the preceding two steps to add an RJ45 connector to the other end of the FE/GE Ethernet cable.
4. Test the continuity of each contact point of the cable and check that the cable is correctly and securely connected by following instructions in section "Testing the Connection of Assembled Cables" of *Installation Reference*.

Step 2 Install the FE/GE Ethernet cable. See Figure 1-26.

Connect one end of the Ethernet cable to the FE/GE0 or FE/GE1 port in the BTS3911E maintenance cavity and the other end to the external transmission equipment.

Figure 1-26 Installing an FE/GE Ethernet cable

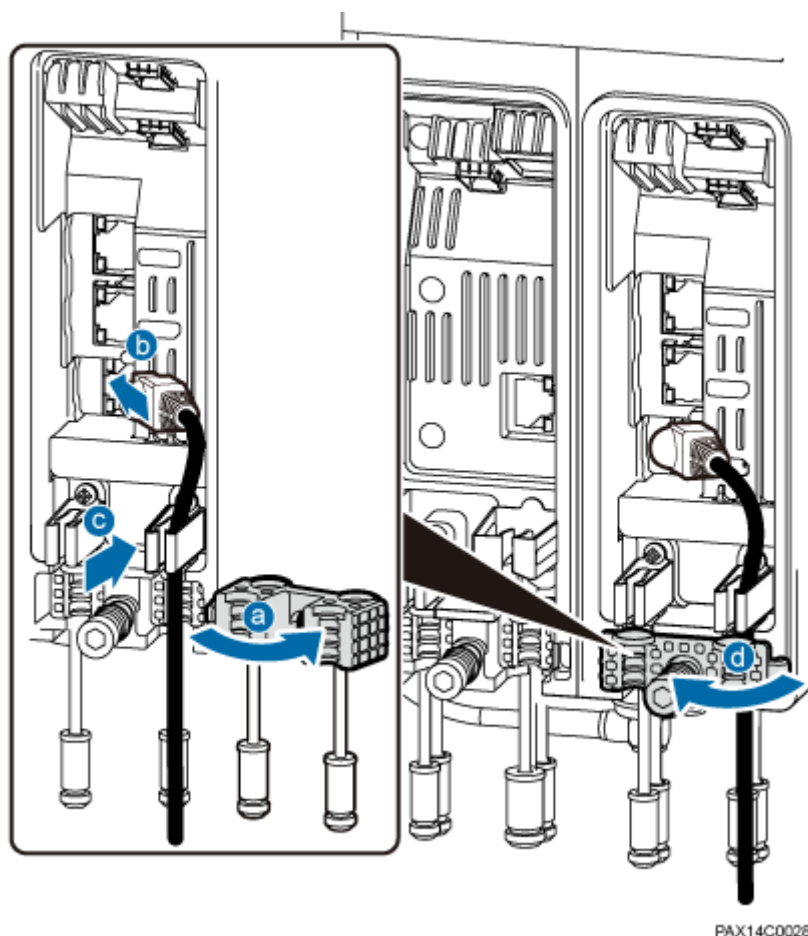

----End

Follow-up Procedure

Route the cable by following instructions provided in section 1.8.1 "Cabling Requirements" and then use cable ties to bind the cable.

1.8.8.3 (Optional) Installing an FE/GE Fiber Optic Cable for Cascading

This section describes the procedure and precautions for installing an FE/GE fiber optic cable used for cascading two BTS3911Es.

Context

- The single-mode optical modules to be installed must match the data rate at the optical ports.
- Do not twist, bend, stretch, or squeeze fiber optic cables during installation.
- Long-time exposure to the air causes performance exceptions on an optical module. Therefore, optical modules must be connected to fiber optic cables within 20 minutes after being unpacked.
- The cable route depends on actual requirements.

Procedure

- Step 1** For both BTS3911Es, remove the dustproof cap from the FE/GE2 or FE/GE3 port. Keep the caps secure.
- Step 2** For both BTS3911Es, insert an optical module into the FE/GE2 or FE/GE3 port, and remove the dustproof cap from the optical module.
- Step 3** Remove the dustproof cap from the optical fiber connector, tidy the optical fibers, and insert the DLC connector into the optical module. See Figure 1-27.

Figure 1-27 Installing a fiber optic cable for cascading

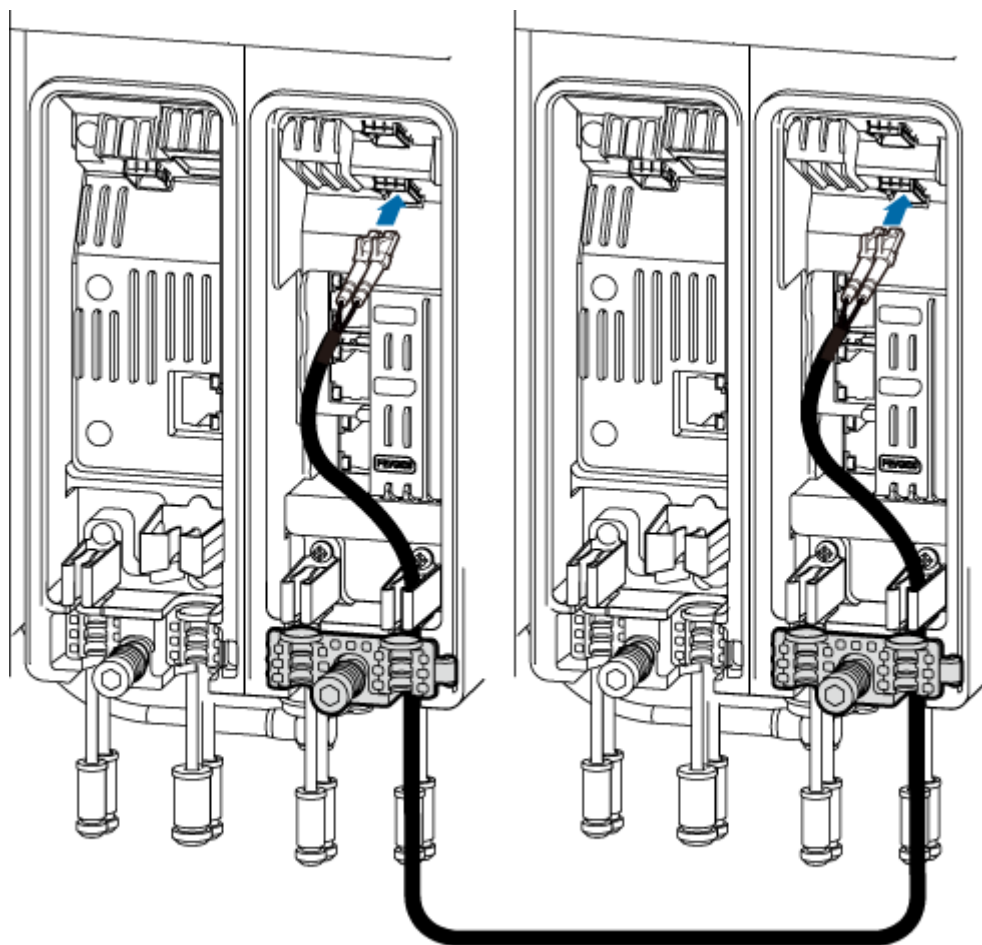

PAX14C0041

----End

Follow-up Procedure

Route the cable by following instructions provided in section 1.8.1 "Cabling Requirements" and then use cable ties to bind the cable.

1.8.8.4 (Optional) Installing an FE/GE Ethernet Cable for Cascading

This section describes the procedure and precautions for installing an FE/GE Ethernet cable used for cascading two BTS3911Es.

Context

An FE/GE Ethernet cable must be a shielded straight-through cable.

Procedure

Step 1 Make an FE/GE Ethernet cable.

1. Add an RJ45 connector to one end of the FE/GE Ethernet cable by following instructions in section 1.11.3 Assembling a Shielded RJ45 Connector and an Ethernet Cable.
2. Check whether the made RJ45 connector is qualified by following instructions in section "Checking the Appearance of Metal Contact Strips" of *Installation Reference*.
3. Repeat the preceding two steps to add an RJ45 connector to the other end of the FE/GE Ethernet cable.
4. Test the continuity of each contact point of the cable and check that the cable is correctly and securely connected by following instructions in section "Testing the Connection of Assembled Cables" of *Installation Reference*.

Step 2 Install the FE/GE Ethernet cable.

Connect one end of the Ethernet cable to the FE/GE0 or FE/GE1 port on one BTS3911E and the other end to the FE/GE0 or FE/GE1 port on the other BTS3911E. See Figure 1-28.

Figure 1-28 Installing an FE/GE cable

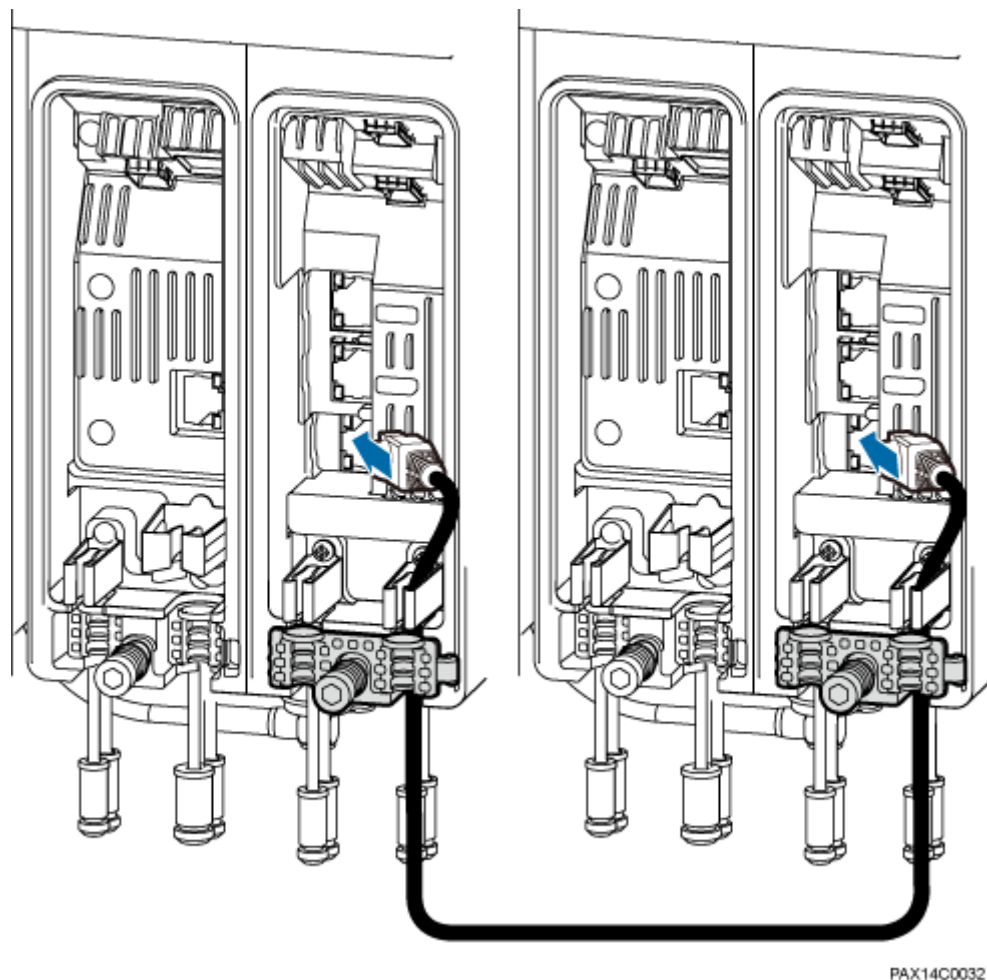

----End

Follow-up Procedure

Route the cable by following instructions provided in section 1.8.1 "Cabling Requirements" and then use cable ties to bind the cable.

1.8.9 Closing the Maintenance Cavity Covers

This section describes the procedure and precautions for closing the maintenance cavity covers of a BTS3911E.

Procedure

- Step 1** Insert waterproof blocks into vacant cable troughs in both the cabling cavities. See Figure 1-29.

 **CAUTION**

Ensure that cables or waterproof blocks are properly inserted into troughs.

Figure 1-29 Checking that vacant cable troughs are properly waterproofed

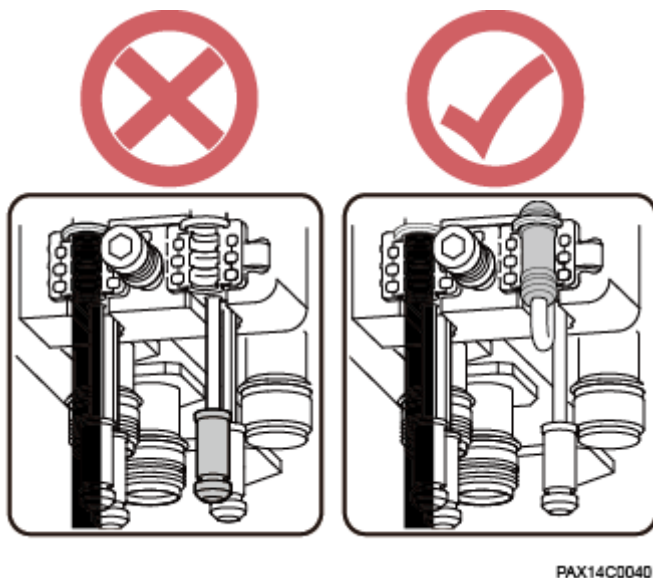

Step 2 Close the maintenance cavity covers of the BTS3911E. Use an M6 hex key screwdriver to torque the screws on the covers to 4.8 N·m. See Figure 1-30.

Figure 1-30 Closing the maintenance cavity covers

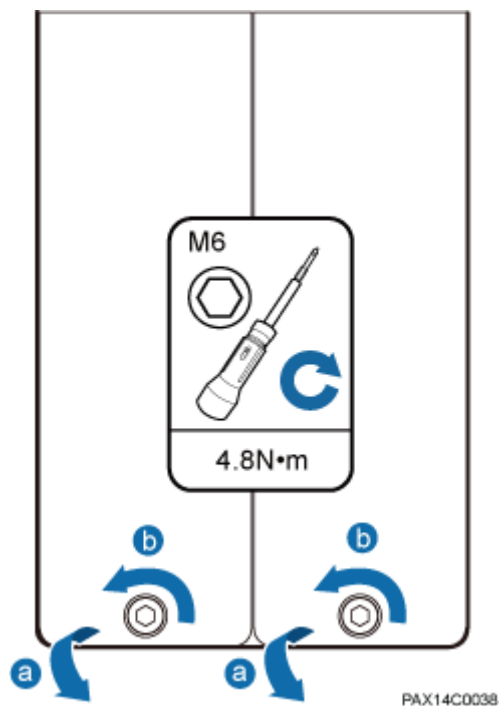

---End

1.8.10 Adjusting Installation Angles

This section describes the procedure and precautions for adjusting the installation angles of a BTS3911E.

Context

After a BTS3911E and its cables are installed, adjust its installation angles through the angle adjusting attachment plate and mounting bracket within a range of -30° to $+30^{\circ}$ in the horizontal and -18° to $+18^{\circ}$ in the vertical.

Procedure

Step 1 Adjust the installation angles of the BTS3911E. See Figure 1-31.

- Adjust the horizontal angle: Use an M10 hex key screwdriver to loosen the angle adjusting screw on the top of the angle adjusting attachment plate. Hold the BTS3911E, properly adjust the horizontal angle, and torque the angle adjusting screw to 7 N m.
- Adjust the vertical angle: Use the M10 hex key screwdriver to loosen the angle adjusting screw on the top of the angle adjusting mounting bracket. Hold the BTS3911E, properly adjust the vertical angle, and torque the angle adjusting screw to 7 N m.

Figure 1-31 Adjusting the installation angles of a BTS3911E

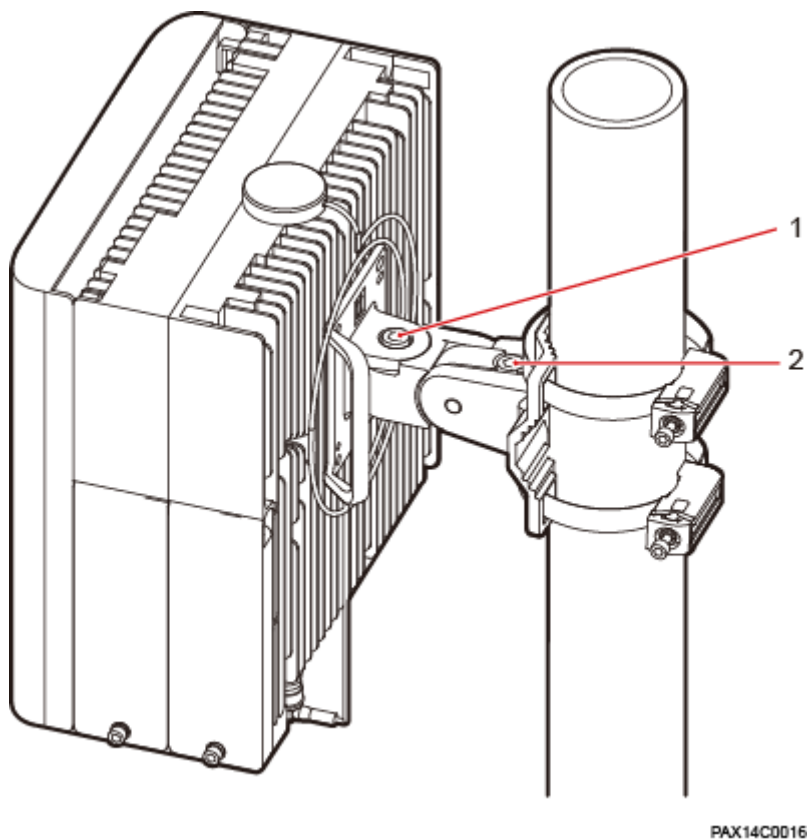

(1) Horizontal angle adjusting screw	(2) Vertical angle adjusting screw
--------------------------------------	------------------------------------

Step 2 Ensure that the horizontal and vertical angle adjusting screws have been secured.

Step 3 Record the horizontal and vertical angles.

----End

1.9 Checking the Hardware Installation

This section describes how to check the hardware installation after a BTS3911E is installed.

Table 1-4 provides the checklist for the BTS3911E hardware installation.

Table 1-4 BTS3911E hardware installation checklist

SN	Item
1	The installation position conforms to the engineering drawing and meets the clearance requirements. Sufficient space is reserved for equipment maintenance.
2	The BTS3911E is securely installed, and the screws are tightened.
3	In wall-mounted scenarios, the mounting holes on the mounting bracket are well aligned with those of the expansion bolts. In addition, the mounting bracket is secured on the wall evenly and steadily.
4	In pole-mounted scenarios, the mounting bracket is secured on the pole.
5	The angle adjustment error of the BTS3911E is less than 3° in the horizontal direction and is not more than 3° in the vertical direction.
6	Vacant cable troughs in both maintenance cavities are covered with waterproof blocks, and the maintenance cavity covers are fastened.
7	None of power cables and PGND cables are short-circuited, reversely connected, damaged, or broken.
8	Power cables and PGND cables are separately bound from other cables.
9	All modules are connected using equipotential cables and then connected to the closest ground bar by using PGND cables.
10	The connectors of each signal cable are intact and securely linked, and these cables are not damaged or broken.
11	Labels are correct, legible, and complete at both ends of each cable.

1.10 Performing a Power-On Check

This section describes the procedure for performing a power-on check on a BTS3911E.

Context



CAUTION

After a BTS3911E is unpacked, power it on within 24 hours. If the BTS3911E is powered off for maintenance, restore power to it within 24 hours.

Figure 1-32 shows the BTS3911E power-on check procedure.

Figure 1-32 Power-on check

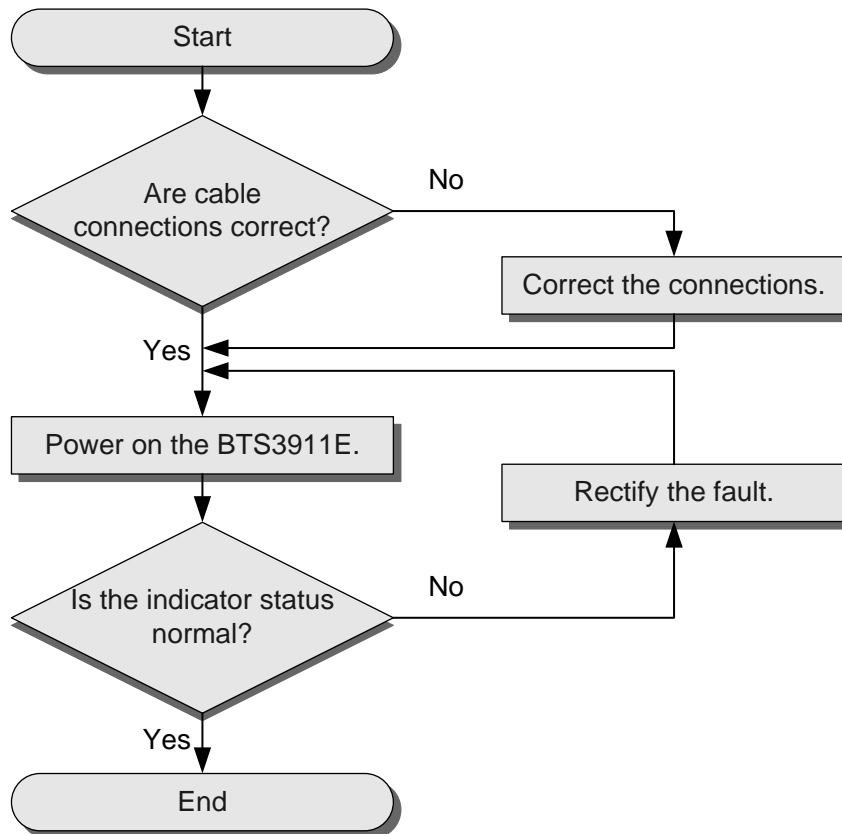

IPP02C0002

Procedure

Step 1 Check that the cables are correctly connected.

- Step 2** Check that the input voltage of the BTS3911E is 110 V AC or 220 V AC, and the frequency ranges from 50 Hz to 60 Hz.
- Step 3** Power on the BTS3911E. Wait 3 to 5 minutes and then observe the indicator status of the BTS3911E. If the RUN indicator blinks (on for 1s and off for 1s) and the ALM indicator is off, the BTS3911E is working properly.



NOTE

- A BTS3911E takes about 3 minutes to complete the startup procedure, during which the indicator status is negligible.
- During a startup, a BTS3911E reads and writes the flash memory and therefore the indicators blinking quickly may blink irregularly for 1s to 2s, which does not affect services.

----End

1.11 References



This section describes reference information and common operations involved during installation.

1.11.1 SN Collection Template

This section describes the SN collection template for BTS3911Es.

The SN collection template is used to record information of BTS3911Es at the initial installation stage to facilitate subsequent commissioning and maintenance. Table 1-5 provides the template.

Table 1-5 SN collection template

No.	Site Number	Site Name	Base Station SN	ODM04A SN	Location Information
<i>Sample</i>	<i>xx</i>	<i>BTS3911E</i>			<i>xx floor, xx building, xx mansion</i>

No.	Site Number	Site Name	Base Station SN	ODM04A SN	Location Information
 NOTE The SN collection template defines the radio network to access and is essential to engineering and subsequent maintenance, especially when multiple devices are installed at a short distance. Carefully maintain this template.					

1.11.2 Assembling a Tool-less Female Connector (Pressfit Type) and a Power Cable

This section describes the procedure for making a tool-less female connector (pressfit type) for a BTS3911E power cable.

Context



DANGER

Strictly follow the procedure described herein to make a tool-less female connector (pressfit type). Any incompliance may cause damage to the BTS3911E or personal injuries.

Figure 1-33 shows the scale for making a power cable for the BTS3911E.

Figure 1-33 BTS3911E power cable-making scale

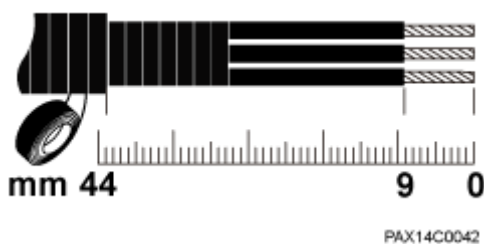

(1) BTS3911E power cable-making scale

Procedure

- Step 2** Unwind the required length of the power cable for different operations based on the scale. See Figure 1-34.

Figure 1-34 Determining the power cable length

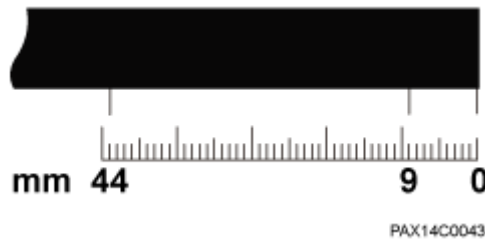

Step 3 Remove the outer jacket of the power cable. See Figure 1-35.

Figure 1-35 Removing the outer jacket of a cable

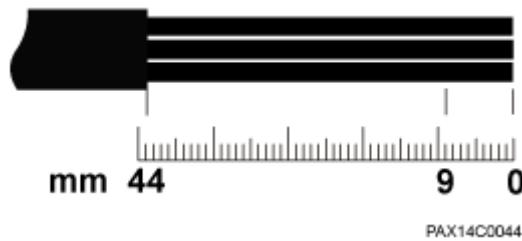

Step 4 Remove the outer jacket of each core wire. The length of the removed outer jacket must match the tool-less female connector (pressfit type). See Figure 1-36.

Figure 1-36 Removing the outer jacket of core wires

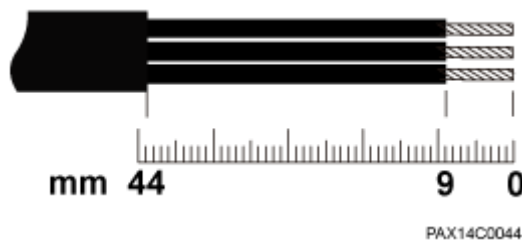

Step 5 Use PVC insulation tapes to wrap the outer jackets of the three core wires and the adjacent section of the AC power cable. See Figure 1-37.

Figure 1-37 Insulating a power cable

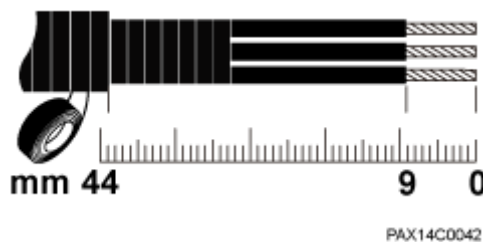

 **NOTE**

It is good practice to wrap the three core wires for 16 mm and the adjacent section of the AC power cable section for about 10 mm.

- Step 6** Assemble a tool-less female connector (pressfit type) and the three core wires. See Figure 1-38.

Figure 1-38 Adding a tool-less female connector (pressfit type) to core wires

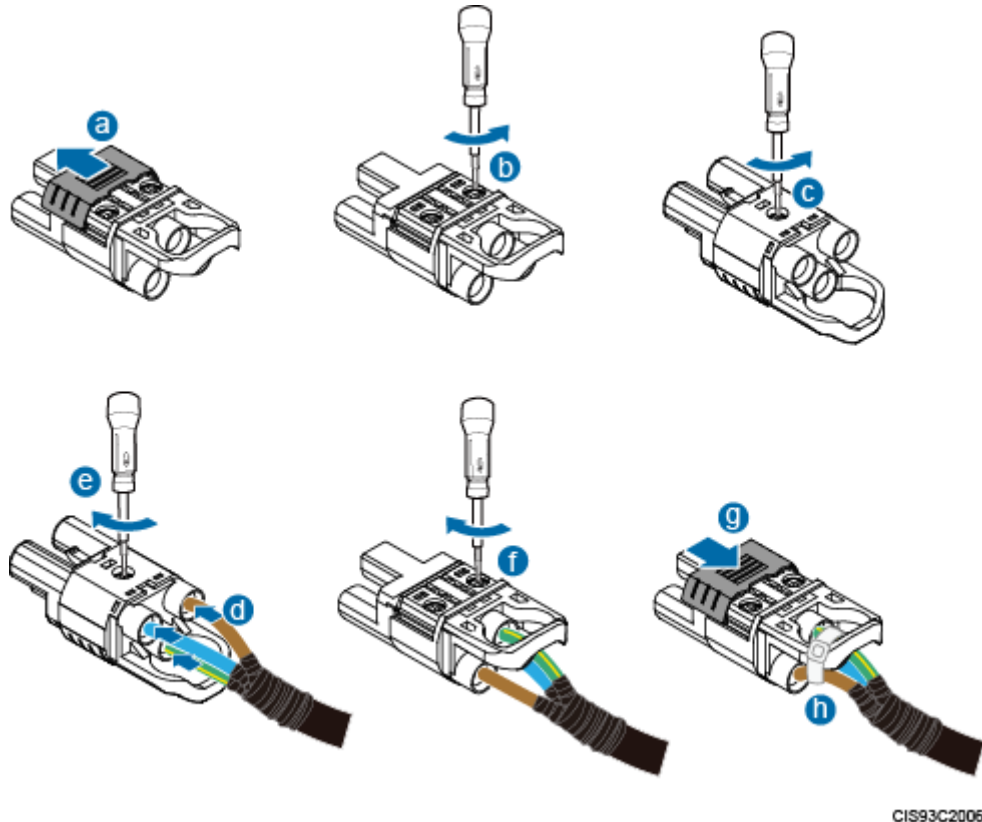

1. Push the sliding block on the connector outwards along the arrow direction.
2. Use an M3 Phillips torque screwdriver to loosen the two screws.
3. Use the M3 Phillips torque screwdriver to loosen the screw on the other side.
4. Insert the brown core wire into the L port, the blue core wire into the N port, and the yellowish green core wire to the PE port.

 **DANGER**

Ensure that the positive and negative wires of all power cables are correctly connected. Any incorrect power cable connection (such as reverse polarity connection) may cause damage to equipment or unexpected personal injuries.

5. Use the M3 Phillips torque screwdriver to torque the screws on both sides to 0.5 N·m.
6. Push the sliding block back in position along the arrow direction.

7. Use cable ties to bind the core wires to the connector.

Step 7 Gently pull each core wire to check that the connections are secure. The core wires can remain fastened under external force of 30 N. Ensure that all copper wires are inserted into the wiring terminal sockets and no copper wire is exposed outside the connector.

----End

1.11.3 Assembling a Shielded RJ45 Connector and an Ethernet Cable

This section describes how to assemble a shielded RJ45 connector and an Ethernet cable. A straight-through cable is used as an example.

Context

Figure 1-39 shows the components of an RJ45 connector and an Ethernet cable.

Figure 1-39 Components of an RJ45 connector and an Ethernet cable

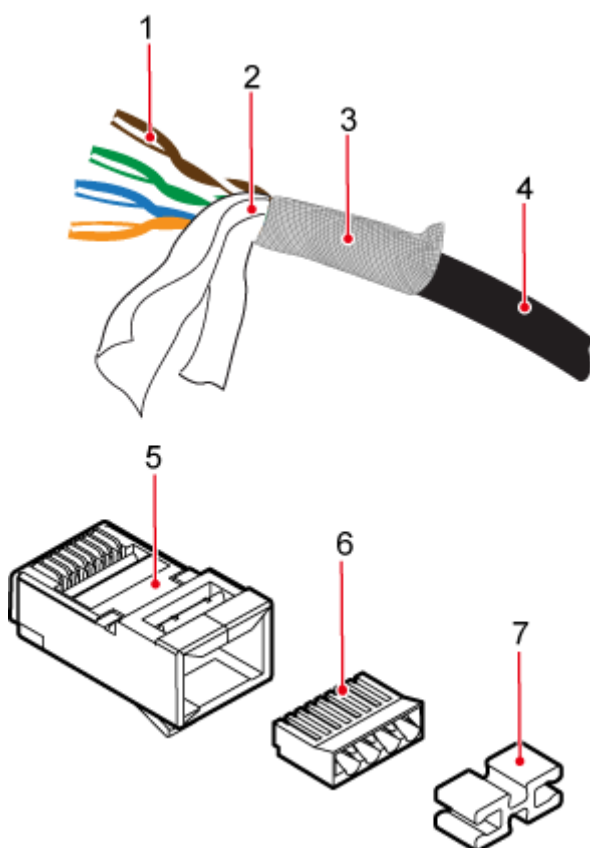

(1) Core wire	(2) Aluminum foil	(3) Braided layer	(4) Outer jacket
(5) RJ45 connector	(6) Load bar	(7) Wire holder	-

Procedure

- Step 1** Remove the outer jacket (20 mm) of the Ethernet cable, tip back the braided layer, and cut off the aluminum foil and guard space. See Figure 1-40.

 **CAUTION**

- Do not damage the shield layer when removing the jacket.
 - Do not damage the insulation layer of the Ethernet cable when removing the shield layer.
-

Figure 1-40 Removing the jacket of an Ethernet cable

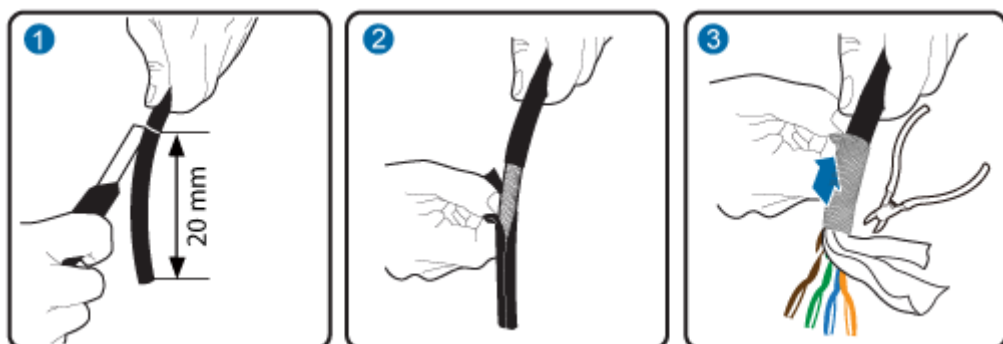

- Step 2** Arrange core wires in the sequence shown in Figure 1-41 and secure the wire holder to the bottom of core wires.

Figure 1-41 Securing the wire holder to the bottom of core wires

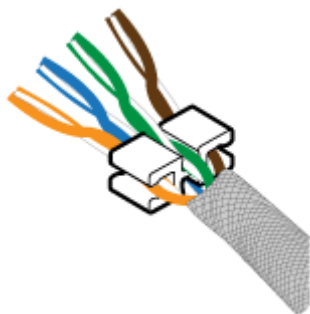

- Step 3** Pinch the core wires into the load bar, as shown in Figure 1-42. Table 1-6 describes mapping between the core wires and pins of the RJ45 connector.

Figure 1-42 Leading core wires through the load bar

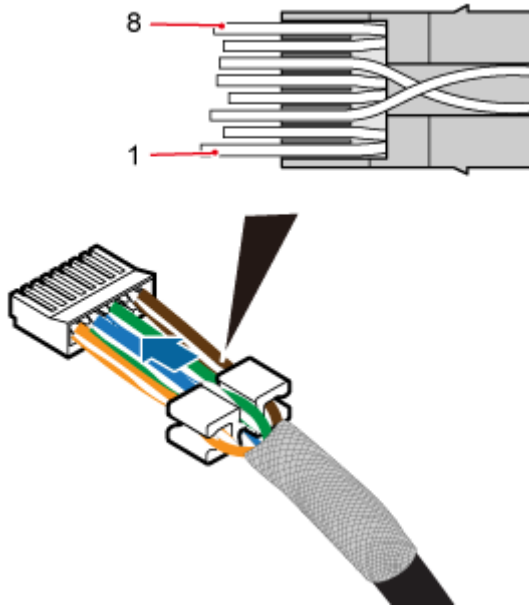
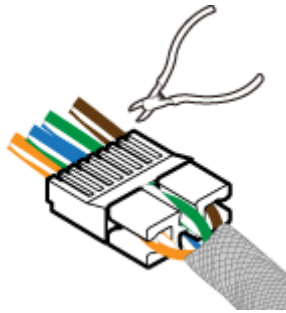

Table 1-6 Pin assignment

Pin SN	Wire Color
1	White and orange
2	Orange
3	White and green
4	Blue
5	White and blue
6	Green
7	White and brown
8	Brown

After pinching the core wires through the load bar, push the load bar along the core wires to the bottom of the wire holder, and evenly cut off the excess part of the core wires. See Figure 1-43.

Figure 1-43 Cutting off the excess part of core wires



Step 4 Insert the load bar into the RJ45 connector. See Figure 1-44.

Figure 1-44 Inserting the load bar into the RJ45 connector

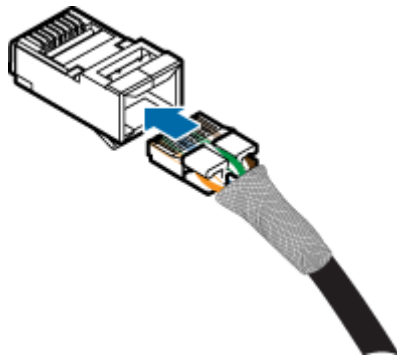

CAUTION

Observe the side or front of the RJ45 connector and ensure that the core wires are inserted to the bottom of the RJ45 connector.

Step 5 Use a crimping tool to crimp the connector. See Figure 1-45.

Figure 1-45 Crimping the connector

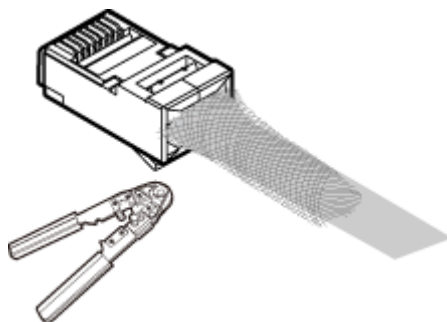

Step 6 Use a cable cutter to evenly cut off the protruding braided layer of the connector along the wire holder. See Figure 1-46.

Figure 1-46 Cutting off the excess braided layer

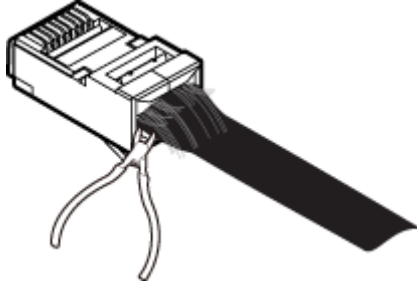

----End

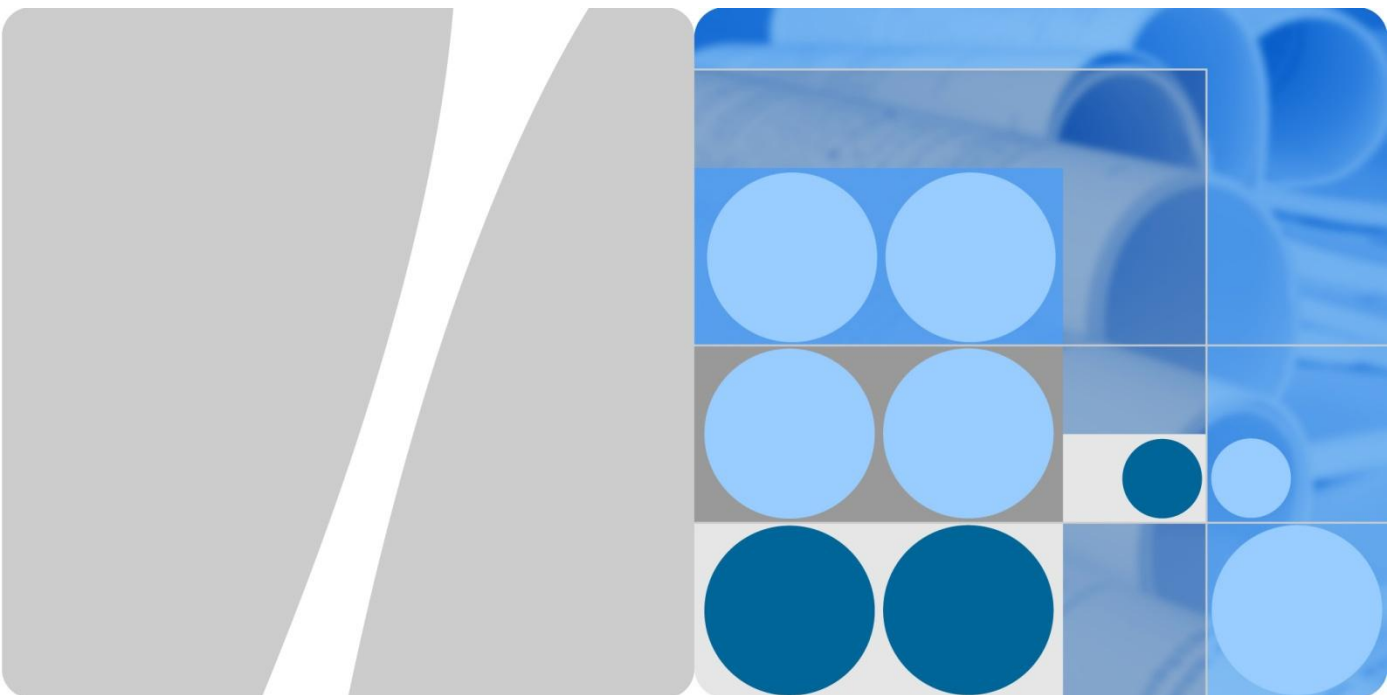

BTS3911E

V100R011C00

Site Maintenance Guide

Issue **Draft A**

Date **2015-07-30**

Copyright © Huawei Technologies Co., Ltd. 2015. All rights reserved.

No part of this document may be reproduced or transmitted in any form or by any means without prior written consent of Huawei Technologies Co., Ltd.

Trademarks and Permissions



and other Huawei trademarks are trademarks of Huawei Technologies Co., Ltd.

All other trademarks and trade names mentioned in this document are the property of their respective holders.

Notice

The purchased products, services and features are stipulated by the contract made between Huawei and the customer. All or part of the products, services and features described in this document may not be within the purchase scope or the usage scope. Unless otherwise specified in the contract, all statements, information, and recommendations in this document are provided "AS IS" without warranties, guarantees or representations of any kind, either express or implied.

The information in this document is subject to change without notice. Every effort has been made in the preparation of this document to ensure accuracy of the contents, but all statements, information, and recommendations in this document do not constitute a warranty of any kind, express or implied.

Huawei Technologies Co., Ltd.

Address: Huawei Industrial Base
Bantian, Longgang
Shenzhen 518129
People's Republic of China

Website: <http://www.huawei.com>

Email: support@huawei.com

Contents

1 BTS3911E Site Maintenance Guide	1
1.1 Changes in BTS3911E Site Maintenance Guide.....	2
1.2 Turning On or Off Indicators	2
1.2.1 Turning On Indicators	2
1.2.2 Turning Off Indicators	2
1.3 Powering On or Off a BTS3911E	3
1.3.1 Powering On a BTS3911E.....	3
1.3.2 Powering Off a BTS3911E	4
1.4 Replacing a BTS3911E.....	4
1.5 Replacing an Optical Module	7

1 BTS3911E Site Maintenance Guide

Introduction

This document describes routine maintenance items for a BTS3911E, such as power-on and power-off operations. It also explains how to replace the components and modules.

Product Version

The following table lists the product version to which this document applies.

Product Name	Product Version
BTS3911E	V100R011C00 and later versions

Intended Audience

This document is intended for:

- System engineers
- Site maintenance engineers

Organization

1.1 Changes in BTS3911E Site Maintenance Guide

This section describes the changes in *BTS3911E Site Maintenance Guide*.

1.2 Turning On or Off Indicators

Indicators on the BTS3911E can be turned on or off.

1.3 Powering On or Off a BTS3911E

The indicator status of a BTS3911E must be observed following a power-on to determine its running status. Normal power-off can be used to power off a BTS3911E.

1.4 Replacing a BTS3911E

BTS3911Es employ modular design and faulty ones must be replaced promptly. Replacing a BTS3911E interrupts all ongoing services carried by it.

1.5 Replacing an Optical Module

An optical module implements photoelectric conversion, enabling optical transmission between a BTS3911E and other devices. Before replacing an optical module, disconnect the fiber optic cable from the optical module. The disconnection interrupts transmission of optical signals.

1.1 Changes in BTS3911E Site Maintenance Guide

This section describes the changes in *BTS3911E Site Maintenance Guide*.

Draft A (2015-07-30)

This is a draft.

1.2 Turning On or Off Indicators

Indicators on the BTS3911E can be turned on or off.

1.2.1 Turning On Indicators

Indicators on a BTS3911E may need to be turned on before routine maintenance is performed.

Procedure

Instruct the network operator to run the **SET INDICATORSW** command on the BTS3911E to turn on the indicators.

Configuration example: `SET INDICATORSW: INDICATORSWITCH=ON;`

The installation or maintenance personnel can locally observe the indicator status.

1.2.2 Turning Off Indicators

After installation or maintenance is completed, indicators on a BTS3911E can be turned off as required.

Procedure

Instruct the network operator to run the **SET INDICATORSW** command on the BTS3911E to turn off the indicators.

Configuration example: `SET INDICATORSW: INDICATORSWITCH=OFF;`

The installation or maintenance personnel can locally observe that all the indicators except the WIFI indicator are off.

1.3 Powering On or Off a BTS3911E

The indicator status of a BTS3911E must be observed following a power-on to determine its running status. Normal power-off can be used to power off a BTS3911E.

1.3.1 Powering On a BTS3911E

This section describes how to power on a BTS3911E and determine its running status by its indicator status.

Prerequisites

- The BTS3911E and its cables have been installed.
- The input voltage of the BTS3911E ranges from 100 V AC to 120 V AC or from 200 V AC to 240 V AC, and the frequency ranges from 50 Hz to 60 Hz.

Context



CAUTION

After a BTS3911E is unpacked, power it on within 24 hours. If the BTS3911E is powered off for maintenance, restore power to it within 24 hours.

Procedure

Step 1 Power on the BTS3911E.



DANGER

Do not look into optical modules without eye protection after the BTS3911E is powered on.

Step 2 Wait for 3 to 5 minutes, and observe the indicator status. Then, take actions based on the indicator status.

Table 1-1 BTS3911E indicator status

If...	Then...
The RUN indicator blinks (on for 1s and off for 1s), the ALM indicator is off, and the BTS3911E is running correctly	End the power-on check task.
Any other indicator status is observed	The BTS3911E is faulty. Rectify the faults, and go to Step 1.



NOTE

- Check the status of indicators on all cascaded BTS3911Es in cascading networking.
- A BTS3911E takes about 3 minutes to complete the startup procedure, during which the indicator status is negligible.
- During a startup, a BTS3911E reads and writes the flash memory and therefore the indicators blinking quickly may blink irregularly for 1s to 2s, which does not affect services.

----End

1.3.2 Powering Off a BTS3911E

This section describes how to power off a BTS3911E.

Procedure

Switch off the external power supply equipment for the BTS3911E.

1.4 Replacing a BTS3911E

BTS3911Es employ modular design and faulty ones must be replaced promptly. Replacing a BTS3911E interrupts all ongoing services carried by it.

Prerequisites

- Tools and materials, such as electrostatic discharge (ESD) gloves, torque wrench, and M10 inner hexagon torque screwdriver, are ready.
- The BTS3911E to be replaced has been confirmed, and a new BTS3911E has been prepared.
- You have obtained keys and site visit permission.

Context



CAUTION

Be careful of the overheat on the surface of a BTS3911E that is running or just powered off. Do not touch it until it cools down.

Procedure

Step 1 Ask the network operator to perform the following preparations for a BTS3911E replacement:

1. Block all the cells served by the BTS3911E to be replaced.
 - Run the **BLK CELL** command if the BTS3911E works in LTE mode.
 - Run the **BLK ULOCELL** command if the BTS3911E works in UMTS mode.
2. Change the SN to that of the new BTS3911E.

3. Upload a configuration file for the new BTS3911E over FTP. For details, see *BTS3911E Commissioning Guide*.
4. Copy the configuration file and required software package to a TF card or a laptop where the LMT has been installed.

Switch off the external power supply equipment for the BTS3911E to be replaced.



CAUTION

Do not touch the BTS3911E that is just powered off until it cools down.

Step 2 Put on ESD gloves.



CAUTION

Take proper ESD protection measures, for example, wear ESD gloves, to prevent electrostatic damage to the BTS3911E or its electronic components.

Step 3 Record the horizontal angle and vertical angle of the BTS3911E. Pay attention to the direction.

Step 4 Record cable connection positions on the bottom and side maintenance cavities of the BTS3911E.

Step 5 Disconnect the cables on the BTS3911E bottom and side maintenance cavities from external devices.

Step 6 Use an M10 inner hexagon torque screwdriver to remove the angle adjusting screw on the top of the BTS3911E attachment plate. Push the BTS3911E and its attachment plate upward out of the angle adjusting mounting bracket. See Figure 1-1.



CAUTION

When demounting a BTS3911E, hold the handles tight and gently lift the BTS3911E to prevent it from falling.

Figure 1-1 Demounting a BTS3911E

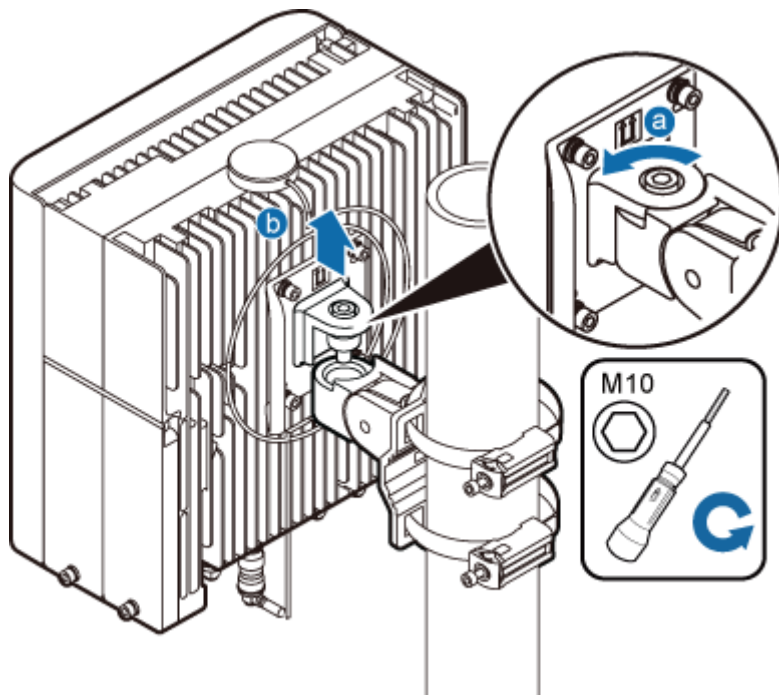

- Step 7** Install a new BTS3911E and adjust the horizontal and vertical angles to be the same as those recorded in Step 3. Use the M10 inner hexagon torque screwdriver to torque the angle adjusting screw on the top to 7 N·m.
- Step 8** Connect all the cables on the new BTS3911E and seal the vacant ports with waterproof rubber plugs.
- Step 9** Power on the new BTS3911E by following instructions provided in 1.3.1 "Powering On a BTS3911E."
- Step 10** Check the operating status of the new BTS3911E by its indicator status. For the meanings of the indicator status, see section "Ports and Indicators" in *BTS3911E Hardware Description*.
- Step 11** Download the configuration file and software package to the new BTS3911E using either of the following methods:
- Using the LMT
 - On the **Upgrade Software** tab page, select **Download Configuration File**, **Download Version Software** to download the configuration file and software package. Select **Activate Configuration File** and **Activate Version Software** to activate the configuration file and software package. After the activation is completed, the BTS3911E automatically restarts and runs the new software. For details, see *LMT User Guide*.
 - Check that no alarm is generated on the new BTS3911E. For details, see *LMT User Guide*.
 - Using a TF card. For details, see *BTS3911E Commissioning Guide*.
- Step 12** Request the network operator to perform the following operations:
1. Unblock all cells served by the BTS3911E.
 - Run the **UBL CELL** command if the BTS3911E works in LTE mode.

- Run the **UBL ULOCELL** command if the BTS3911E works in UMTS mode.
- 2. Manually synchronize inventory data.
- 3. Manually change the BTS3911E status from **TESTING** to **NORMAL**.

Step 13 Take off the ESD gloves and pack up all the tools.

----End

Follow-up Procedure

- Place the replaced BTS3911E into an ESD bag. Then, place the ESD bag into a foam-padded carton or the packing box of the new BTS3911E.
- Fill in the fault form with the detail information of the replaced BTS3911E.
- Contact the local Huawei office to handle the faulty BTS3911E.

1.5 Replacing an Optical Module

An optical module implements photoelectric conversion, enabling optical transmission between a BTS3911E and other devices. Before replacing an optical module, disconnect the fiber optic cable from the optical module. The disconnection interrupts transmission of optical signals.

Prerequisites

- The type and number of optical modules to be replaced are confirmed, and new optical modules are ready.
- Tools and materials, such as ESD gloves, M10 Phillips screwdrivers, ESD box or ESD bag, are ready.

Context

- Optical modules are inserted in FE/GE2 and FE/GE3 ports of the BTS3911E.
- Optical modules are hot-swappable.
- Optical module replacement involves disconnecting the fiber optic cable, removing the faulty optical module, inserting a new optical module, connecting the fiber optic cable to the new module, and waiting for the link on the Ethernet optical port to resume. The whole process takes about 5 minutes.

Procedure

Step 1 Put on ESD gloves.



CAUTION

Take proper ESD protection measures, for example, wear ESD gloves, to prevent electrostatic damage to the boards, modules, or electronic components.

Step 2 Record the connection positions of the faulty optical module and fiber optic cable.

- Step 3** Press the bulge on the optical connector and remove the connector from the faulty optical module.



CAUTION

Do not look into the disconnected fiber optic cable or optical module without eye protection.

- Step 4** Lower the puller on the faulty optical module, and then pull the puller until the optical module is removed from the BTS3911E.

- Step 5** According to the label on the faulty optical module, prepare a new one of the same type. Install the new optical module into the FE/GE optical port on the BTS3911E.



NOTE

The new optical module must match the rate at the optical FE/GE port.

- Step 6** Insert the optical connector into the optical module.

- Step 7** Check the transmission of FE/GE signals by the indicator status. For the meanings of the indicator status, see section "Ports and Indicators" in *BTS3911E Hardware Description*.

- Step 8** Take off the ESD gloves and pack up all the tools.

----End

Follow-up Procedure

- Place the replaced optical module into the ESD box or bag. Then, place the ESD box or bag into a foam-padded carton or the packing box of the new optical module.
- Fill in the fault form with the detail information of the replaced optical module.
- Contact the local Huawei office to handle the faulty optical module.

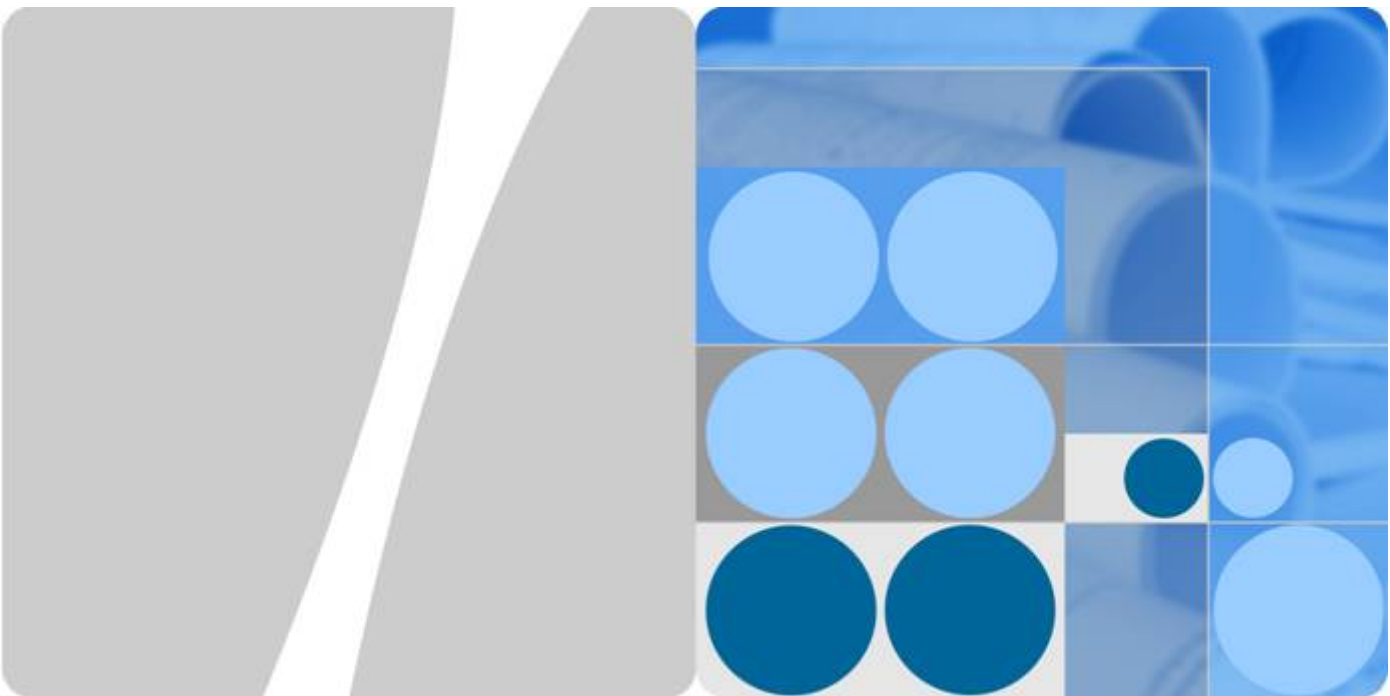

BTS3911E

V100R011C00

Technical Description

Issue **Draft A**

Date **2015-07-30**

Copyright © Huawei Technologies Co., Ltd. 2015. All rights reserved.

No part of this document may be reproduced or transmitted in any form or by any means without prior written consent of Huawei Technologies Co., Ltd.

Trademarks and Permissions



HUAWEI and other Huawei trademarks are trademarks of Huawei Technologies Co., Ltd.

All other trademarks and trade names mentioned in this document are the property of their respective holders.

Notice

The purchased products, services and features are stipulated by the contract made between Huawei and the customer. All or part of the products, services and features described in this document may not be within the purchase scope or the usage scope. Unless otherwise specified in the contract, all statements, information, and recommendations in this document are provided "AS IS" without warranties, guarantees or representations of any kind, either express or implied.

The information in this document is subject to change without notice. Every effort has been made in the preparation of this document to ensure accuracy of the contents, but all statements, information, and recommendations in this document do not constitute a warranty of any kind, express or implied.

Huawei Technologies Co., Ltd.

Address: Huawei Industrial Base
Bantian, Longgang
Shenzhen 518129
People's Republic of China

Website: <http://www.huawei.com>

Email: support@huawei.com

Contents

1 BTS3911E Technical Description.....	1
1.1 Changes in BTS3911E Technical Description.....	3
1.2 Network Architecture.....	3
1.2.1 BTS Node at the RAN Physical Layer.....	3
1.2.2 Base Station at the RAN Logical Layer.....	4
1.2.3 Mapping of a Base Station at the RAN Physical Layer and RAN Logical Layer.....	6
1.3 Logical Structure.....	6
1.3.1 Subsystems.....	6
1.3.2 Functional Structure.....	7
1.3.3 Resource Model.....	8
1.4 Transport Network Topology.....	9
1.5 Operation and Maintenance.....	12
1.5.1 O&M Modes.....	12
1.5.2 O&M Functions.....	13
1.6 Technical Specifications.....	15
1.7 Typical Power Configuration for BTS3911E.....	24
1.8 Reliability.....	27

1 BTS3911E Technical Description

Overview

The BTS3911E is a customer-oriented multimode integrated micro base station. This document describes the BTS3911E in terms of network structure, logical structure, transport network topologies, operation and maintenance, technical specifications, and reliability. This document aims to help user better understand the BTS3911E.

Product Version

The following table lists the product version to which this document applies.

Product Name	Solution Version	Product Version
BTS3911E	<ul style="list-style-type: none">● SRAN11.0● eRAN11.0● RAN18.0	V100R011C00

Intended Audience

This document is intended for:

- Network planning engineers
- Field engineers
- System engineers

Organization

[1.1 Changes in BTS3911E Technical Description](#)

This chapter describes the changes in *BTS3911E Technical Description*.

[1.2 Network Architecture](#)

The radio access network (RAN) is classified into the RAN physical layer and RAN logical layer.

[1.3 Logical Structure](#)

This section describes the logical structure of a base station in terms of subsystems and functional structures.

[1.4 Transport Network Topology](#)

The BTS3911Es support the star and chain topologies on IP networks.

[1.5 Operation and Maintenance](#)

The BTS3911E O&M system manages, monitors, and maintains the BTS3911E software, hardware, and configuration.

[1.6 Technical Specifications](#)

This chapter provides BTS3911E technical specifications, including frequency bands, RF specifications, capacity specifications, signaling specifications, output power and power consumption, transmission port specifications, equipment specifications, environment specifications, and standards compliance.

[1.7 Typical Power Configuration for BTS3911E](#)

The BTS3911E can work in UMTS only, LTE FDD only, or UMTS+LTE mode.

[1.8 Reliability](#)

This chapter describes the reliability of the BTS3911E, including system reliability, hardware reliability and software reliability.

1.1 Changes in BTS3911E Technical Description

This chapter describes the changes in *BTS3911E Technical Description*.

Draft A (2015-07-30)

This is a draft A.

1.2 Network Architecture

The radio access network (RAN) is classified into the RAN physical layer and RAN logical layer.

- The RAN physical layer comprises the physical devices of base stations and base station controllers. The physical devices interwork with each other over transport networks.
- The RAN logical layer comprises logical functions implemented on base stations and those on base station controllers. The logical functions interwork with each other over interface protocols.

1.2.1 BTS Node at the RAN Physical Layer

The RAN physical layer consists of physical base stations (BTS nodes), physical base station controllers (BSC nodes), and the transport network that connects the BTS and BSC nodes.

Figure 1-1 shows the position of BTS nodes at the RAN physical layer.

Figure 1-1 BTS nodes at the RAN physical layer

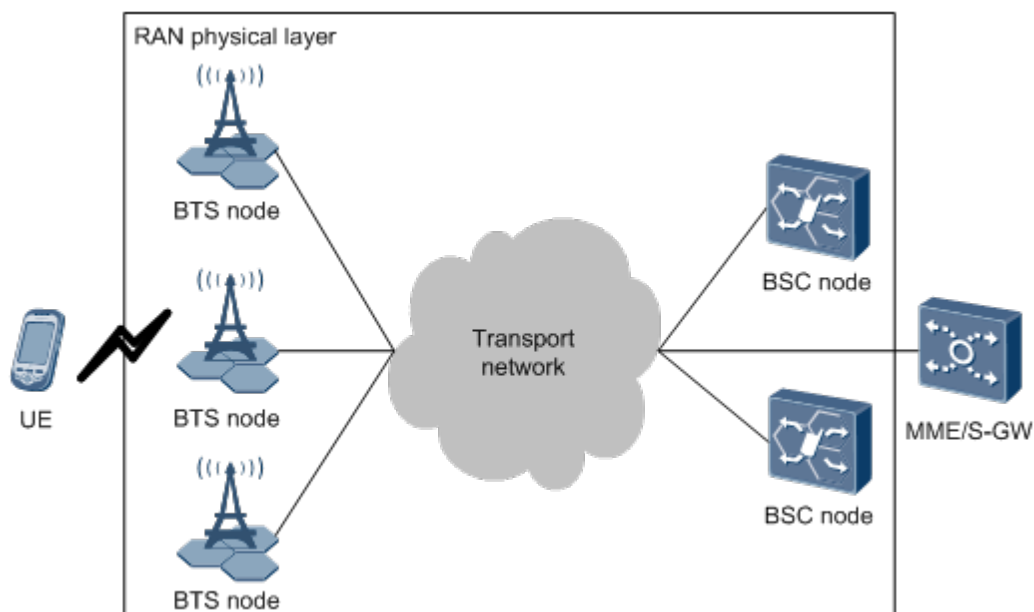

UE: user equipment	BTS node: a physical base station	BSC node: a physical base station controller
MME: mobility management entity	S-GW: serving gateway	-

- **BTS node:** Provides the infrastructure and application platform for a base station to implement NodeB Service and eNodeB Service.
- **BSC node:** Provides RNC Service.
- **Transport network:** Forwards data between a BTS node and a BSC node and between a BTS nodes and the operation and maintenance center (OMC). Multiple modes can use the same transport network or separate transport networks. The BTS3911Es support IP transmission.

1.2.2 Base Station at the RAN Logical Layer

The RAN logical layer is classified into the UTRAN and E-UTRAN. It comprises NodeB Service, eNodeB Service, and RNC Service. Services interwork with each other over interface protocols. NodeB Service and eNodeB Service implement the logical functions of base stations, and RNC Service implements the logical function of base station controllers.

NodeB Service at the UTRAN Logical Layer

The UTRAN logical layer comprises NodeB Service and RNC Service. **Figure 1-2** shows the position of NodeB Service at the UTRAN logical layer.

Figure 1-2 NodeB Service at the UTRAN logical layer

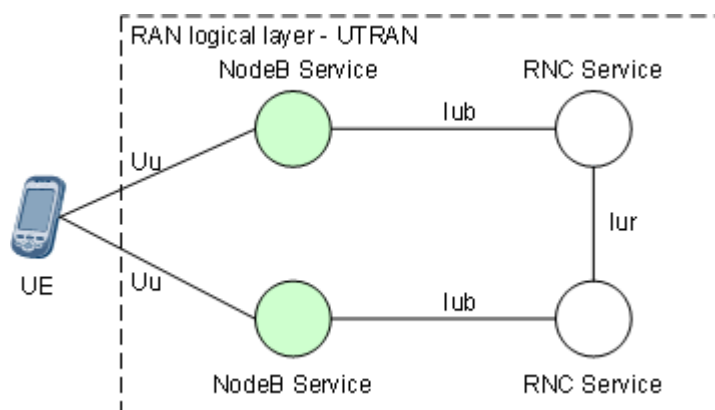

UE: user equipment	NodeB Service: services provided by WCDMA base stations
RNC Service: services provided by WCDMA base station controllers	UTRAN: universal terrestrial radio access network

- NodeB Service: Provides logical functions of WCDMA base stations and is controlled by RNC Service. These functions include radio channel management, physical layer protocol processing, and signaling procedure processing. NodeB Service interworks with RNC Service over the Iub interface and interworks with UEs over the Uu interface.
- RNC Service: Provides logical functions of WCDMA base station controllers. These functions include radio resource management, base station management, mobility management, and access control. RNC Service interworks with each other over the Iur interface.

eNodeB Service at the E-UTRAN Logical Layer

The E-UTRAN logical layer provides eNodeB Service. **Figure 1-3** shows the position of eNodeB Service at the E-UTRAN logical layer.

Figure 1-3 eNodeB Service at the E-UTRAN logical layer

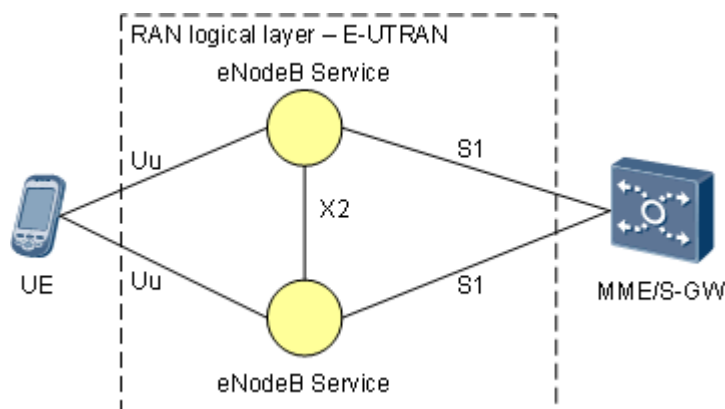

UE: user equipment	eNodeB Service: services provided by LTE base stations
MME/S-GW: mobility management entity and serving gateway	E-UTRAN: evolved universal terrestrial radio access network

eNodeB Service provides logical functions of LTE base stations. These functions include radio resource management, radio channel management, mobility management, physical layer protocol processing, signaling procedure processing, and access control. The LTE FDD single-mode, LTE TDD single-mode, and LTE FDD/LTE TDD dual-mode configurations are supported. eNodeB Service interworks with the MME or S-GW over the S1 interface, with other eNodeB Service over the X2 interface, and with UEs over the Uu interface.

NOTE

The BTS3911Es support LTE FDD but not LTE TDD.

1.2.3 Mapping of a Base Station at the RAN Physical Layer and RAN Logical Layer

The logical functions of a base station are provided by its physical devices. One physical device can be configured with one or several logical functions. One BTS node can provide NodeB Service and eNodeB Service separately or simultaneously.

1.3 Logical Structure

This section describes the logical structure of a base station in terms of subsystems and functional structures.

1.3.1 Subsystems

The base station subsystems include a control subsystem, transport subsystem, baseband subsystem, radio frequency (RF) subsystem, clock subsystem, and power and environment monitoring subsystem.

Figure 1-4 shows the base station subsystems.

Figure 1-4 Base station subsystems

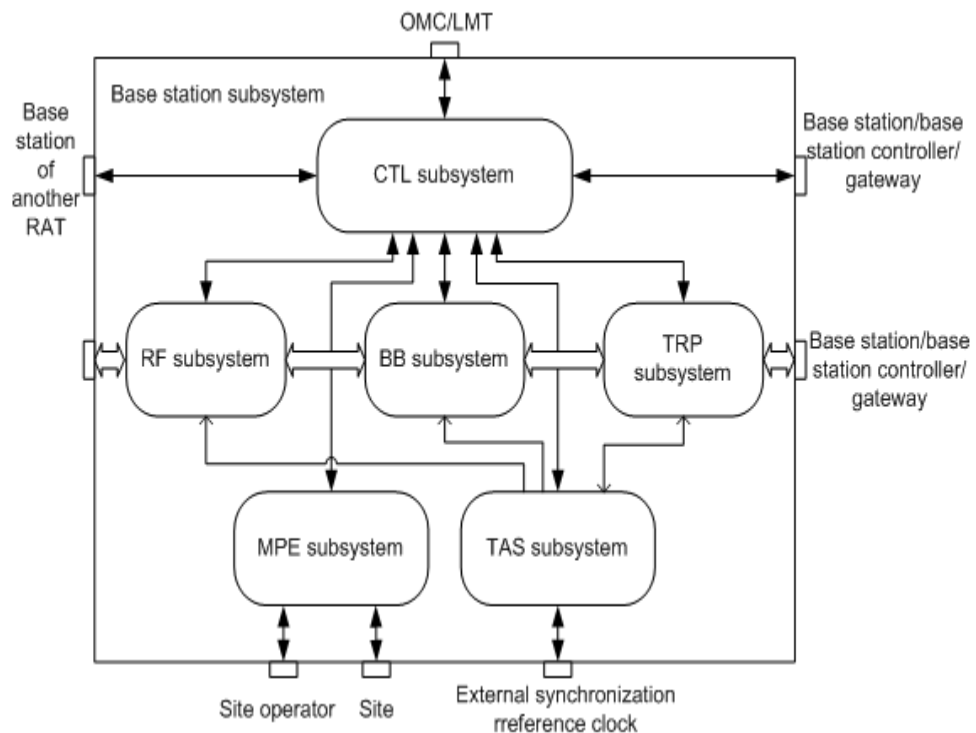

CTL subsystem: control subsystem	TRP subsystem: transport subsystem	BB subsystem: baseband subsystem
----------------------------------	------------------------------------	----------------------------------

RF subsystem: radio frequency subsystem	TAS subsystem: clock subsystem	MPE subsystem: power and environment monitoring subsystem
---	--------------------------------	---

- Control subsystem: Controls and manages resources in a base station. This subsystem provides the management-plane interface toward the OMC, the control-plane interface toward other NEs, and the interface for controlling and negotiating common devices in a multimode base station.
- Transmission subsystem: Forwards data between a base station and a transport network. This subsystem provides physical ports toward a transport network and the user-plane interface toward other NEs.
- Baseband subsystem: Processes uplink and downlink baseband data.
- BTS RF subsystem: Receives and transmits radio signals. This subsystem provides the interface toward the antenna system.
- Clock subsystem: Synchronizes the base station clock with external reference clocks. This subsystem provides the ports toward external reference clocks. For details about multimode clock sharing, see *Common Clock*.
- Power and environment monitoring subsystem: Provides power supply and monitors the environment for a base station. This subsystem provides the ports toward site devices.

1.3.2 Functional Structure

The functional structure of a base station consists of the BTS node, NodeB Service, and eNodeB Service.

Figure 1-5 shows the functional structure of a base station.

Figure 1-5 Functional structure

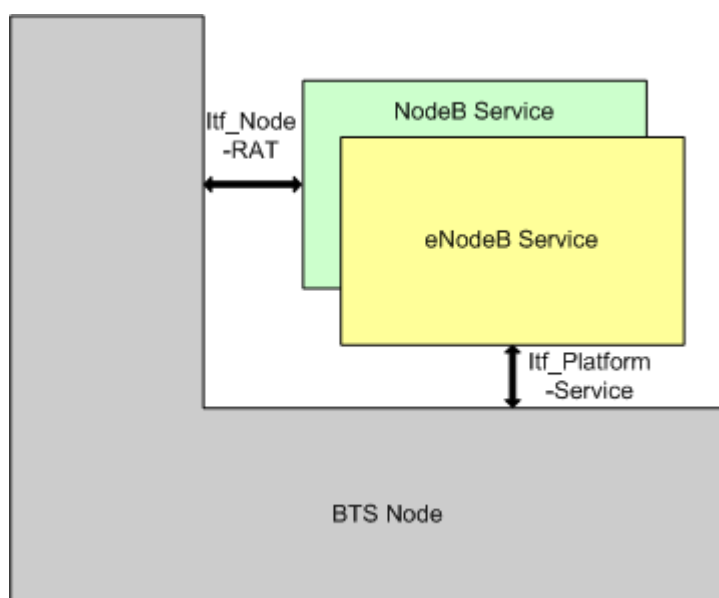

- BTS nodes use abstract resources and a unified interface design to mask software and hardware differences. Therefore, each Service can be flexibly deployed on each type of resources. As a result, resources can be flexibly shared and allocated among each type of Service.
 For details about the function of a BTS node, see section [1.2.1 BTS Node at the RAN Physical Layer](#)"1.2.1 BTS Node at the RAN Physical Layer."
- For details about the function of NodeB Service and eNodeB Service, see section [1.2.2 Base Station at the RAN Logical Layer](#)"1.2.2 Base Station at the RAN Logical Layer."
- Itf_Platform-Service includes the Service control interfaces provided by a BTS node, such as the Service deployment interface, version upgrade interface, start and restart interface, and status monitoring interface.
- Itf_Node-RAT includes the interfaces provided by a BTS node to control the common resources in a base station, such as the resource request, release, activation, and reconfiguration interfaces. Common resources in a base station include transmission resources, carrier resource, and universal resources such as SCTP links, TX and RX channels, and CPU progress.

1.3.3 Resource Model

Function modules of a base station consist of resource modules, including Node, NodeBFunction, and eNodeBFunction. In charge of device and transmission resources, Node implements logical functions of a BTS node. In charge of RAT-specific radio resources, NodeBFunction and eNodeBFunction implement logical functions of NodeB Service and eNodeB Service, respectively.

Figure 1-6 Mapping between a BTS3911E and its resource model

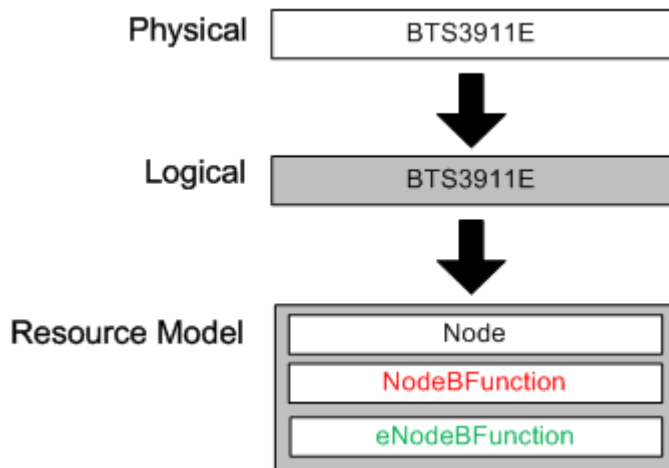

The resource model of a BTS3911E comprises Node and Function of the specific RAT. The resource model is managed on the basis of managed objects (MOs), which are defined by parameters. The MOs and parameters of device and transmission data belong to Node, and those of radio data belong to Function.

Figure 1-7 Resource model

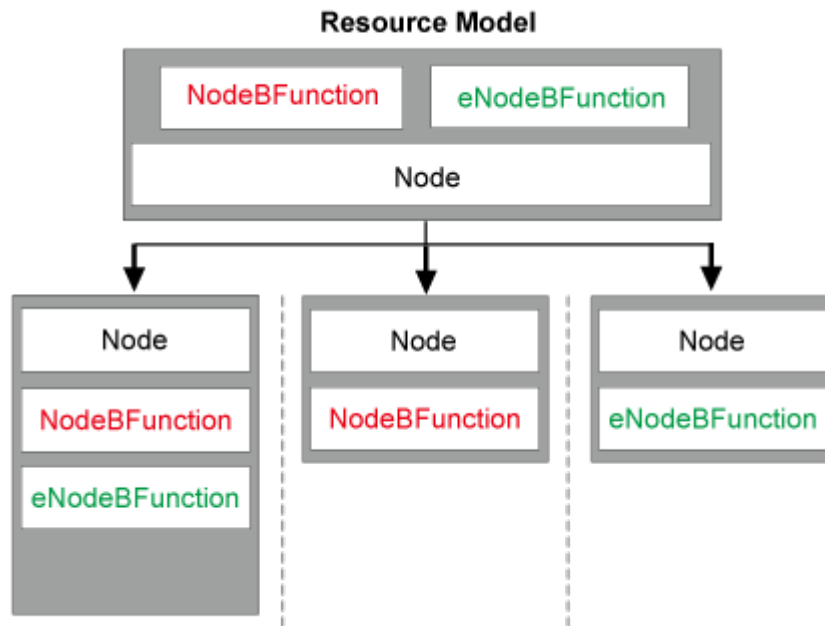

NOTE

For details about the resource model, MOs, and parameters of the BTS3911E, see *BTS3911E Parameter Reference*.

1.4 Transport Network Topology

The BTS3911Es support the star and chain topologies on IP networks.

Table 1-1 describes transmission ports on the BTS3911E.

Table 1-1 Transmission ports

Silkscreen	Description
ETH	FE/GE electrical port
OPT	FE/GE optical port

Star Topology

The star topology is the most commonly used and applies to densely populated areas. **Figure 1-8**

Figure 1-8 Star topology

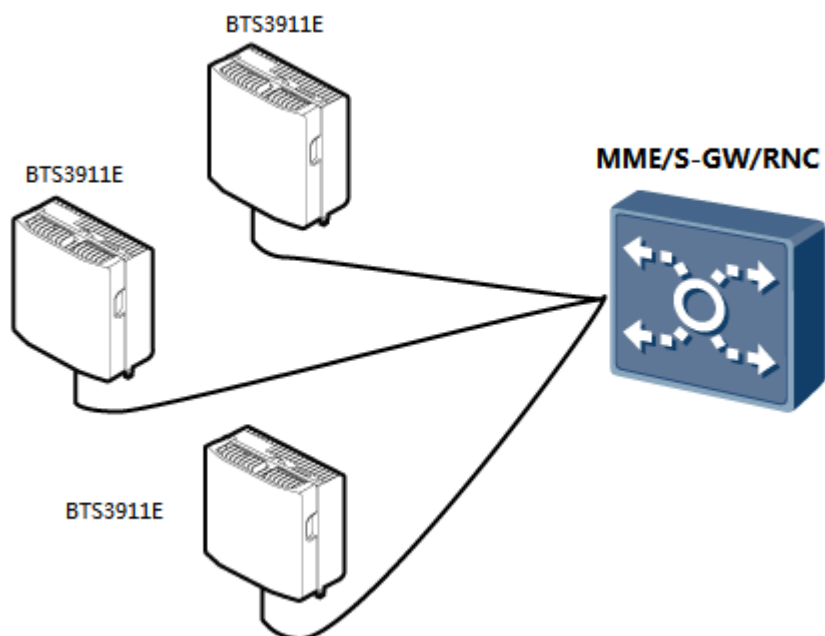

- Advantages
 - Easy engineering, maintenance, and capacity expansion because each BTS3911E directly interconnects with an MME, S-GW, or RNC over a transport network
- High network reliability because each BTS3911E directly exchanges data with an MME, S-GW, or RNC.
- Disadvantage: The star topology requires more transmission resources than the chain topology.

Chain Topology

The chain topology applies to belt-shaped and sparsely populated areas, such as areas along highways and railways. [Figure 1-9](#)

Figure 1-9 Chain topology

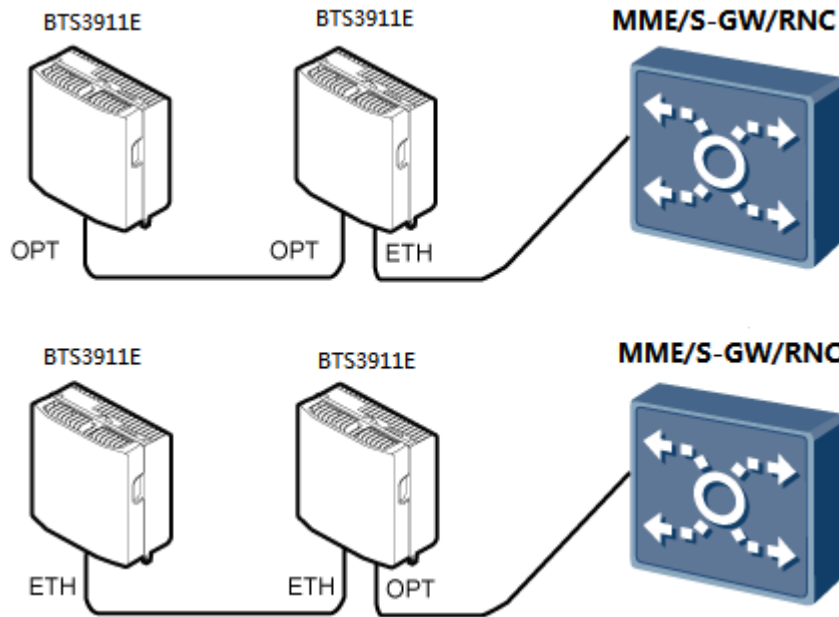

NOTE

- The BTS3911Es do not support the chain topology if the transport network adopts PPPoE authentication.
- A maximum of three levels of BTS3911Es can be cascaded, that is, three BTS3911Es can be cascaded in chain topology for transmission resource sharing.
- A BTS3911E can connect to the transport network over an electrical port or optical port, depending on actual requirements. However, one BTS3911E can use two transmission ports at most, one for connection to the transport network, and the other for cascading.
- Advantage: This topology helps reduce the costs for transmission equipment, construction, and transmission link lease.
- Disadvantages:
 - Signals travel through many nodes, lowering network reliability.
 - Each lower-level BTS3911E occupies some transmission bandwidth of its upper-level BTS3911E. Reliability of the upper-level BTS3911E affects operation of the lower-level BTS3911E.

Chain Topology

The chain topology applies to belt-shaped and sparsely populated areas, such as areas along highways and railways. [Figure 1-10](#)

Figure 1-10 Chain topology

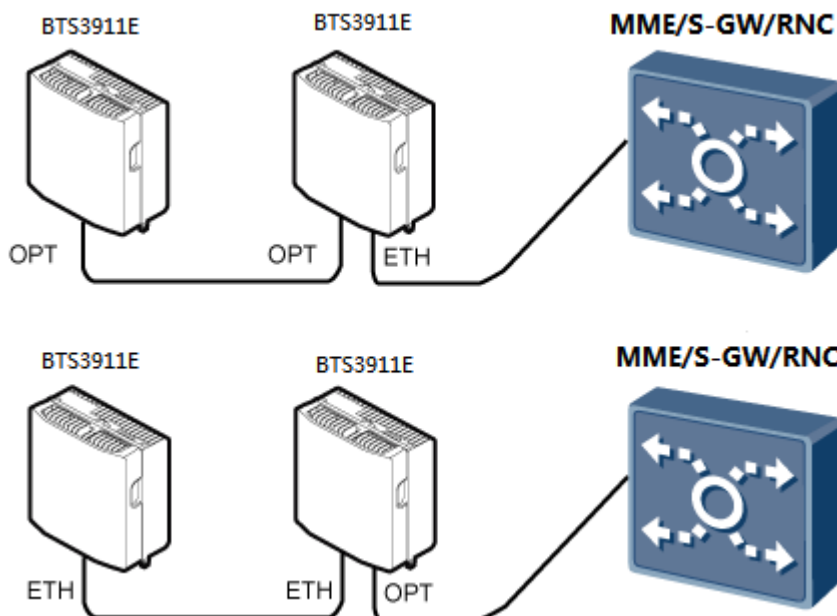

NOTE

- The BTS3911Es do not support the chain topology if the transport network adopts PPPoE authentication.
- A maximum of three levels of BTS3911Es can be cascaded, that is, three BTS3911Es can be cascaded in chain topology for transmission resource sharing.
- A BTS3911E can connect to the transport network over an electrical port or optical port, depending on actual requirements. However, one BTS3911E can use two transmission ports at most, one for connection to the transport network, and the other for cascading.
- Advantage: This topology helps reduce the costs for transmission equipment, construction, and transmission link lease.
- Disadvantages:
 - Signals travel through many nodes, lowering network reliability.
 - Each lower-level BTS3911E occupies some transmission bandwidth of its upper-level BTS3911E. Reliability of the upper-level BTS3911E affects operation of the lower-level BTS3911E.

1.5 Operation and Maintenance

The BTS3911E O&M system manages, monitors, and maintains the BTS3911E software, hardware, and configuration.

1.5.1 O&M Modes

The BTS3911Es support both local and remote operation and maintenance (O&M).

- Local maintenance: Maintains a single BTS3911E on the LMT

- Remote maintenance: Maintain multiple BTS3911Es on the U2000 or LMT at the OMC

 **NOTE**

U2000 is short for iManager U2000 Mobile Element Management System.

Figure 1-11 shows the BTS3911E O&M system.

Figure 1-11 BTS3911E O&M system

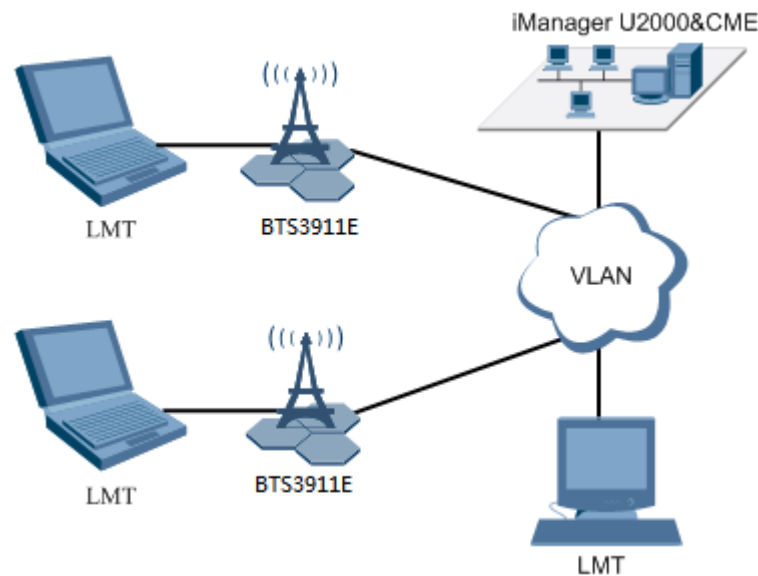

The BTS3911E O&M system includes the following elements:

- LMT: Maintains a single BTS3911E locally or remotely.
- U2000: Maintains multiple BTS3911Es remotely.
- CME: Configures and manages BTS3911E data.
- BTS3911E: Refers to the O&M object.

1.5.2 O&M Functions

The BTS3911E O&M system provides configuration management, fault management, performance management, security management, software management, deployment management, device management, and inventory management.

Configuration Management

Configuration management includes data configuration, query, export, backup, and restoration, as well as configuration synchronization with the U2000.

The data configuration is based on the MOs of the following categories: device, transport, and service. These categories are independent of each other. In most cases, service data reconfiguration does not require device data reconfiguration, and device data reconfiguration does not require service data reconfiguration either.

Fault Management

Fault management involves fault detection, fault isolation, self-healing, alarm reporting, and alarm correlation. The BTS3911E O&M system can manage faults in hardware, environment, software, transmission, cells, and services.

- Fault isolation prevents faults from affecting the BTS3911E operational continuity. Self-healing minimizes the impact of faults on services by lowering specifications or reestablishing cells.
- Alarm correlation enables a BTS3911E to report only the root fault and the ultimate impact on services.

Performance Management

Performance management involves periodic performance measurement on the BTS3911Es and the collection, storage, and reporting of measurement results.

The BTS3911Es collect performance statistics every 5, 15, 30, or 60 minutes and can store the results in a maximum of three days. The performance measurement covers the BTS3911E, cell, neighboring cell, transmission, standard interface, and device usage measurement.

The BTS3911Es support real-time KPI monitoring at intervals of 1 minute, which helps detect and diagnose faults in a timely manner.

Tracing Management

Tracing management facilitates routine maintenance, commissioning, and troubleshooting by tracing internal messages, messages over the interfaces and signaling links, and messages to and from UEs.

Security Management

Security management implements user authentication and access control, including user account management, rights management, login management, identity authentication, and operation authentication.

Transmission channels between the BTS3911Es and the U2000 can run over Secure Socket Layer (SSL).

Security management provides network- and user-specific security services, including the following:

- Encryption: Encrypts important user information.
- Authentication: Manages and authenticates user accounts.
- Access control: controls user operations.
- Security protocol: supports SSL.

Software Management

Software management involves software version management, software version upgrade, and patch management.

- Software version management: Software versions can be queried, backed up, and restored.

- Software version upgrade: The BTS3911Es can be remotely upgraded in batches. With the one-click remote upgrade wizard provided by the U2000, you can:
 - Perform health checks before and after upgrades.
 - Back up, download, and activate software.
 - Check the upgrade status and results.

The BTS3911Es support automatic configuration updates during upgrades. To complete an upgrade, simply follow the instructions on the upgrade wizard. The BTS3911Es also support rapid version rollback by using a single command, reducing the impact of upgrade failures.

- Patch management involves patch query, download, activation, deactivation, rollback, and removal.

Deployment Management

The BTS3911E deployment solutions include automatic BTS3911E discovery, BTS3911E deployment by USB, remote BTS3911E deployment, and radio parameter self-planning. These solutions allow onsite installation personnel to simply install hardware without the need for portable computers, reducing deployment workload and increasing deployment efficiency.

- Automatic BTS3911E discovery: Eliminates the need to configure the IP addresses of the BTS3911Es and the EMS.
- BTS3911E deployment by USB: Downloads software and data stored in a USB flash drive to the BTS3911Es. This reduces the download duration when the bandwidth of transmission between the BTS3911Es and the EMS is insufficient.
- Remote BTS3911E deployment: Allows software commissioning and acceptance at the OMC.
- Radio parameter self-planning: Generates radio parameters for the BTS3911Es in online mode, lessening the workload of parameter planning and configuration.

Device Management

Device management involves data configuration, status management, fault detection, and troubleshooting for all the physical BTS3911E devices. On the BTS3911E device panel, you can easily view the device status and perform simple operations such as query and reset.

Inventory Management

Inventory management involves collection and reporting of the inventory information about BTS3911Es. Inventory management makes it possible to centrally manage network equipment assets at the OMC.

1.6 Technical Specifications

This chapter provides BTS3911E technical specifications, including frequency bands, RF specifications, capacity specifications, signaling specifications, output power and power consumption, transmission port specifications, equipment specifications, environment specifications, and standards compliance.

Frequency Band

Table 1-2 Frequency band

Scenario	Mode	Frequency Band (MHz)	RX Frequency Band (MHz)	TX Frequency Band (MHz)	Support ed Bandwidth (MHz)	IBW (MHz)
1800 MHz	LTE FDD	1800	1710 to 1785	1805 to 1880	5, 10, 15, or 20	40
2100 MHz	LTE FDD	2100	1920 to 1980	2110 to 2170	5, 10, 15, or 20	40
2100 MHz	UMTS	2100	1920 to 1980	2110 to 2170	5	40
2100 MHz LTE FDD +2100 MHz UMTS	LTE FDD	2100	1920 to 1980	2110 to 2170	5, 10, 15, or 20	40
	UMTS	2100	1920 to 1980	2110 to 2170	5	40
1800 MHz LTE FDD +2100 MHz LTE FDD	LTE FDD	1800	1710 to 1785	1805 to 1880	5, 10, 15, or 20	40
	LTE FDD	2100	1920 to 1980	2110 to 2170	5, 10, 15, or 20	40
1800 MHz LTE FDD +2100 MHz UMTS	LTE FDD	1800	1710 to 1785	1805 to 1880	5, 10, 15, or 20	40
	UMTS	2100	1920 to 1980	2110 to 2170	5	40
1800 MHz LTE FDD +2100 MHz LTE FDD+2100 MHz UMTS	LTE FDD	1800	1710 to 1785	1805 to 1880	5, 10, 15, or 20	40
	LTE FDD	2100	1920 to 1980	2110 to 2170	5, 10, 15, or 20	40
	UMTS	2100	1920 to 1980	2110 to 2170	5	40

RF specifications

Table 1-3 describes the TX/RX channel and receive sensitivity of a BTS3911E.

Table 1-3 TX/RX channel and receive sensitivity

Frequency Band (MHz)	TX/RX Channel	Receive Sensitivity (dBm)	
		Single-antenna Receive Sensitivity (dBm)	Dual-antenna Receive Sensitivity (dBm)
1800	2T2R	LTE: -103	LTE: -105.8
2100	2T2R	LTE: -103 UMTS: -123	LTE: -105.8 UMTS: -125.8

 **NOTE**

The receive sensitivity in UMTS mode is measured at the antenna connector under the conditions recommended in 3GPP TS 25.104:

- The channel rate is 12.2 kbit/s.
- The bit error rate does not exceed 0.001.

The receive sensitivity in LTE mode is measured under the conditions recommended in annex A in 3GPP TS 36.104:

- The channel bandwidth is 5 MHz.
- The reference measurement channel is FRC A1-3 in annex A.1 (QPSK, R = 1/3, 25 RBs);

The BTS3911Es support internal and external antennas. [Table 1-4](#) lists the internal antenna specifications.

Table 1-4 Internal antenna specifications

Frequency Band (MHz)	Gain (dBi)	Polarization Mode	Directionality	Vertical Lobe Width (3 dB)	Horizontal Lobe Width (3 dB)	VSWR
1800	11	±45°	Directional	65°	32°	< 2
2100	11	±45°	Directional	65°	32°	< 2

 **NOTE**

The internal antenna of a BTS3911E is not preconfigured with a tilt.

Capacity Specifications

[Table 1-5](#) lists the capacity specifications of a BTS3911E in LTE only mode.

Table 1-5 Capacity specifications in LTE only mode

Item	Specifications
Maximum number of cells per BTS3911E	Three 20 MHz cells NOTE A single-band BTS3911E supports a maximum of two 2T2R cells. A dual-band BTS3911E supports a maximum of three 2T2R cells.
Maximum number of UEs in RRC_Connected mode	<ul style="list-style-type: none"> ● Per cell: 600 ● Per BTS3911E: 1200
Maximum throughput per BTS3911E	<ul style="list-style-type: none"> ● Downlink: 450 Mbit/s ● Uplink: 225 Mbit/s

Table 1-6 lists the capacity specifications of a BTS3911E in UMTS only mode.

Table 1-6 Capacity specifications in UMTS only mode

Item	Specifications
Maximum number of cells per BTS3911E	Four cells
Maximum number of CEs per BTS3911E	<ul style="list-style-type: none"> ● Downlink: 512 CEs ● Uplink: 512 CEs
Maximum number of UEs per BTS3911E	384 HSPA UEs
Maximum throughput per BTS3911E	<ul style="list-style-type: none"> ● Downlink: 168 Mbit/s ● Uplink: 46 Mbit/s

Table 1-7 lists the capacity specifications of a BTS3911E in UMTS+LTE mode.

Table 1-7 Capacity specifications in UMTS+LTE mode

Recommended Configuration	Item	UMTS Specifications	LTE Specifications
Four UMTS cells and one LTE cell	Maximum number of cells per BTS3911E	Four cells	One 20 MHz cell
	Maximum number of UEs per BTS3911E	192 HSPA UEs	600 UEs in RRC_Connected mode

Recommended Configuration	Item	UMTS Specifications	LTE Specifications
	Maximum throughput per BTS3911E	<ul style="list-style-type: none"> ● Downlink: 168 Mbit/s ● Uplink: 46 Mbit/s 	<ul style="list-style-type: none"> ● Downlink: 150 Mbit/s ● Uplink: 75 Mbit/s
	Maximum number of CEs per BTS3911E	<ul style="list-style-type: none"> ● Downlink: 256 CEs ● Uplink: 256 CEs 	-
Two UMTS cells and two LTE cell	Maximum number of cells per BTS3911E	Two cells	Two 20 MHz cells
	Maximum number of UEs per BTS3911E	192 HSPA UEs	600 UEs in RRC_Connected mode
	Maximum throughput per BTS3911E	<ul style="list-style-type: none"> ● Downlink: 84 Mbit/s ● Uplink: 23 Mbit/s 	<ul style="list-style-type: none"> ● Downlink: 300 Mbit/s ● Uplink: 150 Mbit/s
	Maximum number of CEs per BTS3911E	<ul style="list-style-type: none"> ● Downlink: 256 CEs ● Uplink: 256 CEs 	-

 **NOTE**

- A UMTS/LTE FDD dual-mode BTS3911E does not support four UMTS cells and two LTE cells concurrently.
- A maximum of four UMTS cells, two 2T2R LTE cells, or two UMTS cells+one 2T2R LTE cell can be configured for a BTS3911E on a single frequency band.

Signaling Specifications

Table 1-8 Signaling specifications

Mode	Signaling Specifications
LTE	216000 BHCA
UMTS	100 CNBAPS
UL	UMTS 80 CNBAPS + LTE 108000 BHCA

 **NOTE**

Busy hour call attempts (BHCA) indicates the number of calls processed during the busiest hour. The BHCA represents the signaling processing capability of a system because calls require signaling transmission.

Output Power and Power Consumption

Table 1-9 Output power and power consumption

Maximum Output Power (W)	Typical Power Consumption (W)	Maximum Power Consumption (W)
2 x 2 x 5 For details about the typical output power configuration, see 1.7 Typical Power Configuration for BTS3911E .	200	220

 **NOTE**

In the **Maximum Output Power (W)** column, $A \times B \times C$ indicates that a BTS3911E provides A frequency bands with B TX channels per band and C W transmit power per channel.

The preceding output power and consumption excludes the external PoE power supply.

Transmission Port Specifications

Table 1-10 Transmission port specifications

Transmission Port Type	Number of Ports
FE/GE electrical port	2
FE/GE optical port	2

 **NOTE**

The BTS3911E supports external PoE power supply over its FE/GE electrical ports, with a maximum output power of 60 W.

Equipment Specifications

Table 1-11 Clock specifications

Item	Synchronization Precision
IEEE 1588v2-based IP clock	<ul style="list-style-type: none"> ● Frequency synchronization precision: ± 0.05 ppm ● Time synchronization precision: 1.5 us
GPS clock	
Synchronous Ethernet clock	Frequency synchronization precision: ± 0.05 ppm

Table 1-12 Power specifications

Input Power	Voltage Range	Frequency
110 V AC	100 V AC to 120 V AC	50 Hz/60 Hz
220 V AC	200 V AC to 240 V AC	50 Hz/60 Hz

Table 1-13 Dimensions and weight

Item	Specifications
Dimensions (H x W x D)	<ul style="list-style-type: none"> ● With internal antennas: 290 mm x 300 mm x 166 mm ● Without internal antennas: 290 mm x 300 mm x 118 mm
Weight	<ul style="list-style-type: none"> ● With internal antennas: ≤ 13.6 kg ● Without internal antennas: ≤ 11.6 kg

Environment Specifications

Table 1-14 Environment specifications



Item	Specifications
Operating temperature	-40°C to +55°C (with solar radiation) -40°C to +50°C (without solar radiation)
Storage temperature	-40°C to +70°C
Relative humidity	5% RH to 95% RH
Absolute humidity	(1 to 30) g/m ³
Altitude	-60 m to +1800 m
Operating atmospheric pressure	70 kPa to 106 kPa
Operating environment	EUROPEAN ETS 300 019-1-4 Class4.1
Storage environment	ETSI EN300019-1-1 class 1.2 "Weather protected, not temperature-controlled storage locations"
Transportation environment	ETSI EN300019-1-2 class 2.3 "Public transportation"
Protection rating	IP65

Item	Specifications
Anti-seismic performance	IEC 60068-2-57 Environmental testing – Part 2-57: Tests – Test Ff: Vibration – Time-history method ETSI EN300019-2-4 YD5083-99: Interim Provisions for Test of Anti-seismic Performances of Telecommunications Equipment (telecommunications industry standard in People's Republic of China)
Protection against the moisture, salt spray, and fungus	IEC60068-2-30 IEC60068-2-52 IEC60068-2-10
Storage time	To avoid product degradation, it is a good practice to put the BTS3911E into use within the first year of storage.

Standards Compliance

Table 1-15 Standards compliance

Item	Specifications
EMC	The BTS3911E complies with the following standards related to electromagnetic compatibility: <ul style="list-style-type: none"> ● CISPR 22 ● EN 55022 ● EN 301 489-17 ● EN 301 489-23 ● CISPR 24 ● IEC 61000-4-2 ● IEC 61000-4-3 ● IEC 61000-4-4 ● IEC 61000-4-5 ● IEC 61000-4-6 ● IEC 61000-4-29 ● GB 9254 ● ETSI 301 489-1 ● VCCI V-3
3GPP	R99, R4, R5, R6, R7, R8, R9, and R10
Environmental standards	RoHS
Surge protection standards	IEC61000-4-5, IEC 61312-1, and YD 5098

Item	Specifications
Protection standards	YD 5098, YD 5068-98, and IEC 61000-4-5
Safety standards	UL60950-1, IEC60950-1, EN60950-1, AS/NZS60950-1, UL60950-22, IEC60950-22, EN60950-22, and AS/NZS60950-22
Environment standards	IEC 68-2-1, IEC 68-2-2, IEC60068-2-2, ETSI EN300019-1-1, ETSI EN300019-1-2, ETSI EN300019-1-4, and ETSI EN300019-2-4
ETL	<p>Conforms to UL STD.60950-1 & UL STD.60950-22 CERTIFIED TO CAN/CSA STD.C22.2 NO.60950-1-07 & CAN/CSA STD.C22.2 NO.60950-22-07</p> <p>The follow figure shows the identity of ETL:</p>  <p>The logo consists of a circular emblem with 'ETL' in the center, 'LISTED' below it, and 'C' on the left and 'US' on the right. Below the emblem is the word 'Intertek' and the number '4001377'. To the right of the emblem is the text: 'CONFORMS TO UL STD.60950-1 & UL STD.60950-22 CERTIFIED TO CAN/CSA STD. C22.2 NO.60950-1-07 & CAN/CSA STD.C22.2 NO. 60950-22-07'.</p>
Laser safety class	<p>CLASS 1 LASER PRODUCT</p> <p>The follow figure shows the identity of laser safety class:</p>  <p>The label is a rectangular box with a double border containing the text 'CLASS 1 LASER PRODUCT'.</p>

Port Surge Protection Specifications

Table 6-2 lists the port surge protection specifications of a BTS3911E.

 **NOTE**

Unless otherwise specified, the surge protection specifications are based on the surge waveform of 8/20 μ s.

All the surge current items, unless otherwise specified as maximum discharge current, refer to nominal discharge current.

Table 1-16 Surge protection specifications

Port	Surge Protection Mode	Specification
AC power socket	Differential mode	20 kA
	Common mode	20 kA

1.7 Typical Power Configuration for BTS3911E

The BTS3911E can work in UMTS only, LTE FDD only, or UMTS+LTE mode.

Table 1-17 and **Table 1-18** describe the typical power configuration for a BTS3911E working in LTE FDD only mode at the 1800 MHz or 2100 MHz band.

Table 1-19 and **Table 1-20** describe the typical power configuration for a BTS3911E working in UMTS only mode at the 2100 MHz band.

Table 1-21 and **Table 1-22** describe the typical power configuration for a BTS3911E working in UMTS+LTE FDD mode at the 2100 MHz band.

 **NOTE**

- A BTS3911E working in LTE FDD only mode can be configured with a maximum of three carriers: a maximum of two carriers on one frequency band and the remaining carriers allocated to the other frequency band
- A BTS3911E working in UMTS only mode can be configured with a maximum of four carriers.
- A BTS3911E working in UMTS+LTE FDD mode can be configured with a maximum of four UMTS carriers plus one LTE carrier or two UMTS carriers plus two LTE carriers: a maximum of two UMTS carriers plus one LTE carrier on one frequency band and the remaining carriers allocated to the other frequency band

Table 1-17 Typical power configuration in LTE FDD only mode at the 1800 MHz or 2100 MHz band

Mode	Number of LTE FDD Carriers	Output Power per LTE FDD Carrier (W)	Supported LTE FDD Cell Bandwidth (MHz)
LTE FDD	1 (MIMO)	2x5	5, 10, 15, 20
	2 (MIMO)	2x2.5	5, 10, 15, 20

Table 1-18 Typical PA power configuration in LTE FDD only mode at the 1800 MHz or 2100 MHz band

Carrier Configuration	PA 1		PA 2	
	Total Number of LTE FDD Carriers	Output Power per LTE FDD Carrier (W)	Total Number of LTE FDD Carriers	Output Power per LTE FDD Carrier (W)
One LTE FDD carrier (MIMO)	1	5	1	5
Two LTE FDD carriers (MIMO)	2	2.5	2	2.5

Table 1-19 Typical power configuration in UMTS only mode at the 2100 MHz band

Mode	Total Number of UMTS Carriers	Output Power per UMTS Carrier (W)
UMTS	1	Configured on one PA: 5
	2	Configured on one PA: 2.5
	3	Configured on one PA: 1.7
	4	Configured on one PA: 1.25
	1 (MIMO)	2x5
	2 (MIMO)	2x2.5
	3 (MIMO)	2x1.7
	4 (MIMO)	2x1.25

Table 1-20 Typical PA power configuration in UMTS only mode at the 2100 MHz band

Carrier Configuration	PA1		PA2	
	Total Number of UMTS Carriers	Output Power per UMTS Carrier (W)	Total Number of UMTS Carriers	Output Power per UMTS Carrier (W)
One carrier	1	5	0	0
Two carriers	2	2.5	0	0
Three carriers	3	1.7	0	0
Four carriers	4	1.25	0	0
One carrier (MIMO)	1	5	1	5
Two carriers (MIMO)	2	2.5	2	2.5
Three carriers (MIMO)	3	1.7	3	1.7
Four carriers (MIMO)	4	1.25	4	1.25

Table 1-21 Typical power configuration in UMTS+LTE FDD mode at the 2100 MHz band

Mode	Total Number of UMTS Carriers	Total Number of LTE FDD Carriers	Output Power per UMTS Carrier (W)	Output Power per LTE FDD Carrier (W)	Supported LTE FDD Bandwidth
UMTS +LTE FDD	1	1 (MIMO)	Configured on one PA: 2.5	2x2.5	5, 10, 15, 20
UMTS +LTE FDD	2	1 (MIMO)	Configured on one PA: 1.7	2x1.7	5, 10, 15, 20
UMTS +LTE FDD	1 (MIMO)	1 (MIMO)	2x2.5	2x2.5	5, 10, 15, 20
UMTS +LTE FDD	2 (MIMO)	1 (MIMO)	2x1.7	2x1.7	5, 10, 15, 20

Table 1-22 Typical PA power configuration in UMTS+LTE FDD mode at the 2100 MHz band

Carrier Configuration	PA1				PA2			
	Total Number of UMTS Carriers	Output Power per UMTS Carrier (W)	Total Number of LTE FDD Carriers	Output Power per LTE FDD Carrier (W)	Total Number of UMTS Carriers	Output Power per UMTS Carrier (W)	Total Number of LTE FDD Carriers	Output Power per LTE FDD Carrier (W)
One UMTS carrier +One LTE FDD carrier (MIMO)	1	2.5	1	2.5	0	0	1	2.5
Two UMTS carriers +One LTE FDD carrier (MIMO)	2	1.7	1	1.7	0	0	1	1.7
One UMTS carrier (MIMO)+One LTE FDD carrier (MIMO)	1	2.5	1	2.5	1	2.5	1	2.5
Two UMTS carriers (MIMO)+One LTE FDD carrier (MIMO)	2	1.7	1	1.7	2	1.7	1	1.7

1.8 Reliability

This chapter describes the reliability of the BTS3911E, including system reliability, hardware reliability and software reliability.

System Reliability

The BTS3911Es adopt redundancy design and improved fault detection and isolation solutions to enhance system reliability.

- Redundancy
Key files, such as software versions and data configuration files, all support redundancy.
- Reliability
A BTS3911E automatically detects and diagnoses faults in the software, hardware, and environment, and reports alarms. Then, the BTS3911E takes self-healing measures to clear the faults. If the faults cannot be cleared, the BTS3911E isolates the faulty units.

Hardware Reliability

- Overtemperature protection
If the temperature around a power amplifier (PA) in a BTS3911E is too high, the BTS3911E reports an overtemperature alarm and handles the problem as follows:
 - If the temperature is higher than the threshold for a major alarm, the BTS3911E switches off the PA and stops providing services. This protects the BTS3911E from damage caused by increasing temperature.
 - If the temperature is higher than the threshold for a minor alarm, the BTS3911E enables the temperature derating function to ensure the services of admitted UEs and refuses the access requests of new UEs to prevent the temperature from keeping increasing.
This function protects the PA from damage caused by overtemperature.
- Reliable power supply
The BTS3911Es use the following techniques to achieve a reliable power supply:
 - Support for a wide-range of voltages as well as surge protection
 - Power failure protection for programs and data
 - Power supply protection against overvoltage, overcurrent, and reverse polarity protection and negative poles
 - Surge protection
The BTS3911Es take surge protection measures on AC power sockets, FE/GE ports, antenna connectors, and clock ports.

Software Reliability

- Redundancy
To ensure normal operation of a BTS3911E when errors occur in important files or data, the BTS3911E provides the following redundancy functions:

- Software version redundancy: The BTS3911E stores software versions, including the BootROM version, in different partitions to provide redundancy. If the active version is abnormal, the BTS3911E switches to the backup version.
- Data configuration file redundancy: The BTS3911E stores data configuration files in different partitions to provide redundancy. If the current file is damaged, the BTS3911E can continue working properly by loading the backup file.
- Error tolerance capability
If software errors occur, the self-healing capability prevents the BTS3911Es from collapse. The software error tolerance capability covers the following aspects:
 - Scheduled checks of key resources: A BTS3911E checks software resource usage and generates related logs and alarms. This allows the BTS3911E to release unavailable resources.
 - Task monitoring: When software is running, a BTS3911E monitors the running status of every task for errors and faults. If an error or fault is detected, an alarm is reported and self-healing measures are taken to restore the task.
 - Data check: A BTS3911E performs scheduled or event-triggered data consistency checks and restores data consistency selectively or preferentially. In addition, the BTS3911E generates related logs and alarms.
 - Watchdog: In the event of a software error, a BTS3911E detects the error using the software and hardware watchdogs and automatically restarts.