



DRH3917A&DRH3919A&DRH3919B& DRH3985A Hardware Maintenance Guide

Issue **Draft A**
Date **2013-08-20**

Copyright © Huawei Technologies Co., Ltd. 2013. All rights reserved.

No part of this document may be reproduced or transmitted in any form or by any means without prior written consent of Huawei Technologies Co., Ltd.

Trademarks and Permissions



and other Huawei trademarks are trademarks of Huawei Technologies Co., Ltd.

All other trademarks and trade names mentioned in this document are the property of their respective holders.

Notice

The purchased products, services and features are stipulated by the contract made between Huawei and the customer. All or part of the products, services and features described in this document may not be within the purchase scope or the usage scope. Unless otherwise specified in the contract, all statements, information, and recommendations in this document are provided "AS IS" without warranties, guarantees or representations of any kind, either express or implied.

The information in this document is subject to change without notice. Every effort has been made in the preparation of this document to ensure accuracy of the contents, but all statements, information, and recommendations in this document do not constitute a warranty of any kind, express or implied.

Huawei Technologies Co., Ltd.

Address: Huawei Industrial Base
Bantian, Longgang
Shenzhen 518129
People's Republic of China

Website: <http://www.huawei.com>

Email: support@huawei.com

About This Document

Purpose

This document describes routine maintenance procedures for a DRH (referred to as DRH in this document), such as equipment preventive maintenance and power-on and power-off operations. It also explains how to replace the DRH and optical modules.

Product Version

The following table lists the product version related to this document.

Product Name	Product Version
DBS3900 IBS	V100R001C02

Scope of application

The following table lists the product version related to this document.

DRH Name	DRH Version
DRH3917A	V100R001C02
DRH3919A	V100R001C02
DRH3919B	V100R001C02
DRH3985A	V100R001C02

Intended Audience

This document is intended for:

- System engineers
- Site maintenance engineers

Organization

1 Changes in the DRH Hardware Maintenance Guide

This chapter describes the changes in the *DRH Hardware Maintenance Guide*.

2 Preventative Maintenance Items for a DRH

Preventative maintenance for a DRH improves the reliability of the DRH. You are advised to perform scheduled maintenance yearly.

3 Powering On and Off a DRH

After a DRH is powered on, check the status of DRH indicators and voltage. Before the DRH is powered off, follow the normal power-off or emergent power-off procedure as required.

4 Replacing a DRH

A distributed base station consists of DRHs and a DCU. Replacing a DRH interrupts all the services carried by the DRH, and alarms are generated.

5 Replacing an Optical Module

An optical module implements optical-electrical conversion, enabling optical transmission between a DRH and other devices. You must disconnect fiber optic cables from an optical module before replacing the optical module. Disconnecting the fiber optic cables interrupts the transmission of CPRI signals.

Contents

About This Document	ii
1 Changes in the DRH Hardware Maintenance Guide	1
2 Preventative Maintenance Items for a DRH	2
3 Powering On and Off a DRH	4
3.1 Powering On an DRH.....	4
3.2 Powering Off a DRH	5
4 Replacing a DRH	6
5 Replacing an Optical Module	9

1 Changes in the DRH Hardware Maintenance Guide

This chapter describes the changes in the *DRH Hardware Maintenance Guide*.

Issue Draft A (2013-08-20)

This is the Draft A version.

2 Preventative Maintenance Items for a DRH

Preventative maintenance for a DRH improves the reliability of the DRH. You are advised to perform scheduled maintenance yearly.



DANGER

While working at heights, be careful not to drop any tools, equipment, or other objects. Falling objects may cause serious injury or death. Always wear a helmet and avoid standing in the danger area.

The items in the following checklist are not mandatory but strongly recommended. [Table 2-1](#) lists the preventative maintenance items for a DRH.

Table 2-1 Preventative maintenance items for a DRH

SN	Item
1	All DRHs are properly installed and in good condition.
2	Cables are sealed properly at the entry points of the cabinet.
3	All RF cables are free from wear, cuts, cracks, or other damage.
4	All RF cable connectors are sealed properly.
5	All RF cable conduits are in good condition.
6	All power cables are free from wear, cuts, cracks, or other damage.
7	All power cable connectors are in good condition.
8	All power cable conduits are in good condition.
9	All shield layers of power cables are in good condition.
10	All power cables are sealed properly.
11	All CPRI fiber optic cables are free from wear, cuts, cracks, or other damage.

SN	Item
12	All screws are tightened on the cover plate of the cabling cavity.
13	All RET cables (optional) are free from wear, cuts, cracks, or other damage.
14	All RET cable (optional) connectors are sealed properly.
15	All alarm cables (optional) are installed and free from any damage.

If any of the statements in the checklist cannot be complied with, perform the following corrective actions:

1. Tighten all connections.
2. Report any other faults found when filling in the checklist to the supervisor, because only technically-qualified and trained field engineers are permitted to climb towers for further repairs.

3 Powering On and Off a DRH

After a DRH is powered on, check the status of DRH indicators and voltage. Before the DRH is powered off, follow the normal power-off or emergent power-off procedure as required.

3.1 Powering On an DRH

Set the corresponding circuit breaker on the auxiliary power device for the DRH to ON, and check the operating status of the DRH by observing the status of DRH indicators.

Prerequisites

- The DRH hardware is installed and DRH cable connections are secure.
- The input voltage of the DRH ranges from -36 V DC to -57 V DC.

Context



After you unpack a DRH, you must power on it within 24 hours. If you power off the DRH for maintenance, you must restore power to the DRH within 24 hours.

Procedure

- Step 1** Set the corresponding circuit breaker on the auxiliary power device for the DRH to ON to power on the DRH.



Do not look into the optical module without eye protection after the DRH is powered on.

- Step 2** Keep the DRH running for three to five minutes to check the status of DRH indicators. For details, see DRH Indicators.

Step 3 Take corresponding actions based on the status of the indicators.

If...	Then...
The DRH is working properly	End the power-on check task.
The DRH is faulty	Set the circuit breaker to OFF. Rectify the fault, and then go to Step 1 .

----End

3.2 Powering Off a DRH

A DRH can be powered off in two ways: normal power-off and emergency power-off. You must power off a DRH in a normal situation such as moving the equipment or anticipating a territorial blackout. You must also power off a DRH in an emergency such as a fire, smoke, or water immersion occurs in the equipment room.

Procedure

- Normal power-off
 1. Set the corresponding circuit breaker on the auxiliary power device for the DRH to OFF.
- Emergency power-off



Emergency power-off may damage the DRH. Therefore, this type of power-off is not recommended in normal cases.

-
1. Shut off the external input power of the auxiliary power device for the DRH.
 2. If time permits, set the corresponding circuit breaker on the auxiliary power device for the DRH to OFF.

----End

4 Replacing a DRH

This chapter describes the procedure and precautions for replacing a DRH.

Prerequisites

- The WebLMT or M2000 communicates with the station properly.
- The types of faulty DRHs are confirmed as follows:
 - Log in to the WebLMT or M2000 and run the MML command to query the manufacturing information of the DRHs. The types of DRHs to be replaced can be determined according to the values of **Type** and **Description** in the command execution result.
 - Run the **DSP BRDMFRINFO** command.
- Tools and materials, such as ESD gloves, M5 Phillips screwdrivers, M6 Phillips screwdrivers, M6 inner hexagon torque wrench, waterproof tape, and PVC insulation tape, are ready.
- The number and type of DRHs to be replaced are confirmed, and new DRHs are ready.

Procedure

- Step 1** Run the **BLK BRD** command to block the DRH.
- Step 2** Power off the DRH by referring to [3.2 Powering Off a DRH](#).
- Step 3** Wear ESD gloves.



CAUTION

- Take proper ESD protection measures, for example, wear ESD gloves, to prevent electrostatic damage to the boards, modules, or electronic components.
 - Pay attention to the high temperature while replacing a DRH without housing.
-

- Step 4** Loosen the protection screw on the cover plate of the DRH cabling cavity using an M4 Phillips screwdriver, and then push the handle outwards to open the cover plate.
- Step 5** Record all the cable connections on the panel of the module to be replaced.
- Step 6** Disconnect cables from the cabling cavity and bottom panel.

Step 7 Loosen the captive screws on the two hoist clamps on the main mounting bracket using an M4 Phillips screwdriver, as shown in [Figure 4-1](#).

NOTE

In scenarios where DRHs are installed in centralized mode, the DRH in the middle can be removed without removing the two DRHs on its right and left sides, in the same procedure as that for removing a single DRH.

Figure 4-1 Loosening captive screws on the main mounting bracket

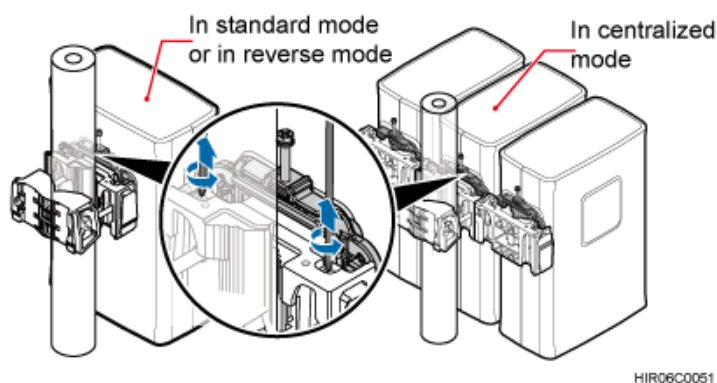

Step 8 Tighten the screws on the attachment plate of the DRH using an M6 Phillips screwdriver, as shown in [Figure 4-2](#). Use the screw only for removing the DRH to loosen the connection between the attachment plate and the main mounting bracket, and then support the DRH bottom to remove it, as shown in [Figure 4-3](#).

Figure 4-2 Tightening screws on the attachment plate

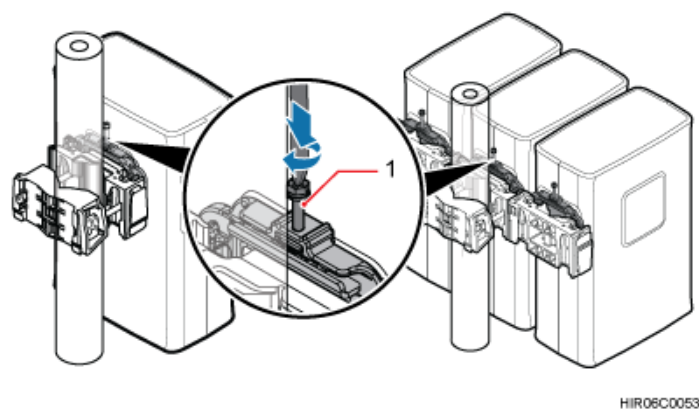
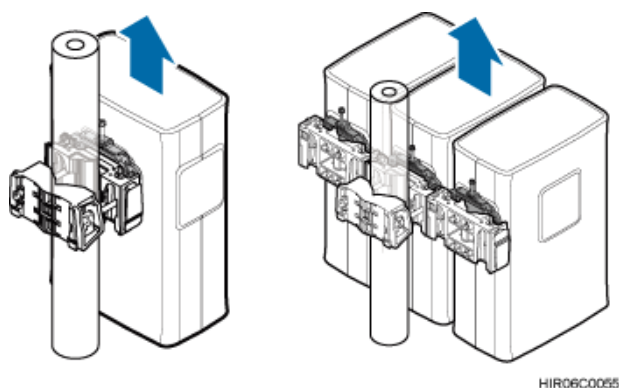

Figure 4-3 Supporting the DRH bottom**CAUTION**

When removing the DRH, hold the DRH handle with one hand and support the DRH bottom with the other hand.

- Step 9** Tighten the captive screws on the two hoist clamps on the main mounting bracket to 1.4 N·m (12.39 lbf in.). Install a new DRH and then waterproof the DRH.
- Step 10** Reconnect all required cables, and verify that vacant cable troughs in the cabling cavity are equipped by waterproof blocks.
- Step 11** Close the cover plate of the DRH cabling cavity, and then tighten the protection screw on the cover plate to 0.8 N·m (7.08 lbf in.).
- Step 12** Power on the DRH by referring to [3.1 Powering On a DRH](#).
- Step 13** Check the operating status of the new DRH by observing the status of DRH indicators. For details about the status of the indicators, see DRH Indicators.
- Step 14** Run the **UBL BRD** command to unblock the DRH.
- Step 15** Take off the ESD gloves, and pack up all the tools.
- End

Follow-up Procedure

- Place the removed DRH into the ESD box or bag. Then, place the ESD box or bag into a foam-padded carton or the packing box of the new DRH.
- Fill in the fault form with detailed information about the removed component.
- Contact the local Huawei office to handle the faulty component.

5 Replacing an Optical Module

An optical module implements optical-electrical conversion, enabling optical transmission between a DRH and other devices. You must disconnect optical fibers from an optical module before replacing the optical module. Disconnecting the optical fibers interrupts the transmission of CPRI signals.

Prerequisites

- The type and number of optical modules to be replaced are confirmed, and new optical modules are ready.
- Tools and materials, such as ESD gloves, M4 Phillips screwdrivers, and an ESD box or bag, are ready.

Context

- Optical modules are inserted into CPRI0 and CPRI1 ports on a DRH.
- Optical modules are hot-swappable when the same CPRI ports are used.
- It takes about five minutes to replace an optical module on the DRH, which involves disconnecting fiber optic cables, removing the faulty optical module, inserting a new optical module, reconnecting the fiber optic cables, and waiting for CPRI links to resume.

Procedure

Step 1 Wear ESD gloves.



CAUTION

Take proper ESD protection measures, for example, wear ESD gloves, to prevent electrostatic damage to the boards, modules, or electronic components.

Step 2 Loosen the protection screw on the cover plate of the DRH cabling cavity using an M4 Phillips screwdriver, and then push the handle outwards to open the cover plate.

Step 3 Record the connections of the optical module and fiber optic cables.

If...	Then...
The faulty optical module is inserted into the CPRI0 port and cables are connected to the DB15 port	Go to Step 4 .
In other cases	Go to Step 5 .

Step 4 Remove the DB15 connector.

Step 5 Press the latch on the fiber optic cable connector, and then remove the connector from the faulty optical module.



WARNING

Do not look into the fiber optic cable or optical module without eye protection after the fiber optic cable is removed from the optical module.

Step 6 Lower the puller on the faulty optical module, and then pull the puller until the optical module is removed from the DRH.

Step 7 Choose the optical module of the same type as the faulty optical module according to the label on the module. Install a new optical module into the DRH.



NOTE

The optical modules to be installed must match CPRI rates.

Step 8 Insert the fiber optic cable connector into the new optical module.

Step 9 Check the transmission of CPRI signals by observing the status of CPRI0/IR0 and CPRI1/IR1 indicators. For details about the status of the indicators, see DRH Indicators.

Step 10 Reconnect the cables in the cabling cavity.

If...	Then...
Cables are disconnected from the DB15 port previously	Go to Step 11 .
In other cases	Go to Step 12 .

Step 11 Insert the DB15 connector.

Step 12 Close the cover plate of the DRH cabling cavity, and then tighten the protection screw on the cover plate to 0.8 N·m (7.08 lbf·in.).

Step 13 Take off the ESD gloves, and pack up all the tools.

----End

Follow-up Procedure

- Place the removed optical module into the ESD box or bag. Then, place the ESD box or bag into a foam-padded carton or the packing box of the new module.
- Fill in the fault form with detailed information about the removed component.
- Contact the local Huawei office to handle the faulty optical module.