



HUAWEI FP2025/2225

Fixed Wireless Terminal

USER GUIDE

Copyright © Huawei Technologies Co., Ltd. 2010. All rights reserved.

No part of this document may be reproduced or transmitted in any form or by any means without prior written consent of Huawei Technologies Co., Ltd.

The product described in this manual may include copyrighted software of Huawei Technologies Co., Ltd and possible licensors. Customers shall not in any manner reproduce, distribute, modify, decompile, disassemble, decrypt, extract, reverse engineer, lease, assign, or sublicense the said software, unless such restrictions are prohibited by applicable laws or such actions are approved by respective copyright holders under licenses.

Trademarks and Permissions



HUAWEI, HUAWEI, and



are trademarks or registered trademarks of Huawei Technologies Co., Ltd.

Other trademarks, product, service and company names mentioned are the property of their respective owners.

Notice

Some features of the product and its accessories described herein rely on the software installed, capacities and settings of local network, and may not be activated or may be limited by local network operators or network service providers, thus the descriptions herein may not exactly match the product or its accessories you purchase.

Huawei Technologies Co., Ltd reserves the right to change or modify any information or specifications contained in this manual without prior notice or obligation.

NO WARRANTY

THE CONTENTS OF THIS MANUAL ARE PROVIDED "AS IS". EXCEPT AS REQUIRED BY APPLICABLE LAWS, NO WARRANTIES OF ANY KIND, EITHER EXPRESS OR IMPLIED, INCLUDING BUT NOT LIMITED TO, THE IMPLIED WARRANTIES OF MERCHANTABILITY AND FITNESS FOR A PARTICULAR PURPOSE, ARE MADE IN RELATION TO THE ACCURACY, RELIABILITY OR CONTENTS OF THIS MANUAL.

TO THE MAXIMUM EXTENT PERMITTED BY APPLICABLE LAW, IN NO CASE SHALL HUAWEI TECHNOLOGIES CO., LTD BE LIABLE FOR ANY SPECIAL, INCIDENTAL, INDIRECT, OR CONSEQUENTIAL DAMAGES, OR LOST PROFITS, BUSINESS, REVENUE, DATA, GOODWILL OR ANTICIPATED SAVINGS.

Import and Export Regulations





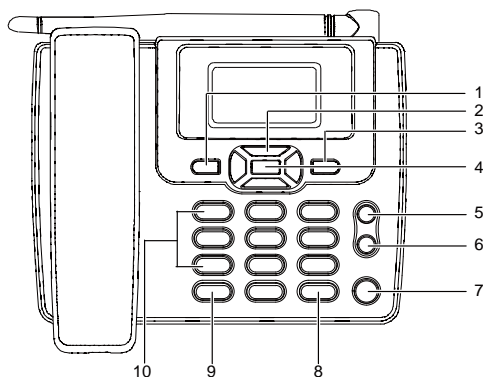

Customers shall comply with all applicable export or import laws and regulations and will obtain all necessary governmental permits and licenses in order to export, re-export or import the product mentioned in this manual including the software and technical data therein.

Your Fixed Wireless Terminal











Note:

The figures of the FWT (Fixed Wireless Terminal) are only for your reference, please refer color and shape to product.

No.	Item	Description
1	Left soft key 	Select the option displayed on the lower left corner of the screen.
2	Scroll keys 	<ul style="list-style-type: none"> Access the shortcut screen in standby mode. Adjust the microphone and the earpiece volume during a call.
3	Right soft key 	Select the option displayed on the lower right corner of the screen.
4	OK key 	<ul style="list-style-type: none"> Access the main menu in standby mode. Select the option displayed on the lower left corner of the display screen.
5	End key 	<ul style="list-style-type: none"> End a call or reject an incoming call. Power on or off the FWT in standby mode (by pressing and holding it). Return to the standby mode.
6	Hands-free key 	<ul style="list-style-type: none"> Activate/deactivate the hands-free mode in standby mode. Cancel the dialing, when dialing a number in the hands-free mode. End the current call during a call in the hands-free mode.
7	Call/Redial key 	<ul style="list-style-type: none"> Make or answer a call. View the call history in standby mode.

No.	Item	Description
8	# key	<ul style="list-style-type: none"> Lock the keypad in standby mode (by pressing and holding it). Switch between different input modes in editing mode.
9	* key	<ul style="list-style-type: none"> Activate/deactivate the quiet profile in standby mode (by pressing and holding it). Access the symbol screen in editing mode.
10	Number keys	<ul style="list-style-type: none"> Number keys from 0 to 9: Enter numbers and characters. Number keys from 1 to 9: Press and hold a key to speed dial a phone number in standby mode.

Screen Icons

Icon	Description	Icon	Description
	Network signal strength		Calling / No service
	Alarm clock is on		Hands-free mode
	Message received		Powered by the power adapter
	Voice message received		Battery power level

Menu Tree

Phone Book 1. Search 2. Add New 3. Groups 4. Speed Dial 5. Copy All (Optional) 6. Delete All 7. My Phone Num 8. Memory Status	Messages 1. Write Message 2. Inbox 3. Outbox 4. Draft 5. Voice Mail 6. Message Settings 7. Delete All	CallHistory 1. Missed Calls 2. Received Calls 3. Dialed Calls 4. Call Duration 5. Delete All
Recorder (Optional) 1. Guest Announcements 2. Recorder Settings	Fun&Utility 1. Alarm 2. Schedule 3. Calculator 4. Stopwatch 5. World Clock 6. Line Game 7. Smash Game	Profiles 1. General 2. Outdoor 3. Quiet

Settings		FM Radio (Optional)		
1. Display				
2. Call Settings				
3. Phone Settings				
4. Security				

Installing the UIM Card (Optional)

Consult the service provider whether the UIM card is needed.

Power off the FWT and remove the power supply cable, and install the UIM card as shown. Make sure that the golden contact on the UIM card is facing downwards.

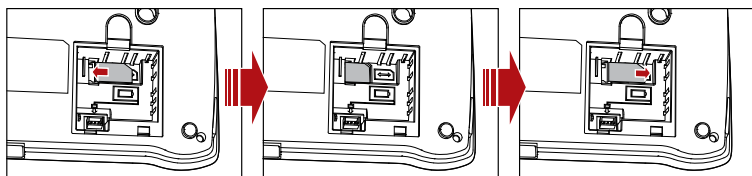

Installing the Battery

Power off the FWT and remove the power supply cable, and install the battery as shown. Make sure that the battery cord plug matches the battery jack. Do not insert the battery reversely.

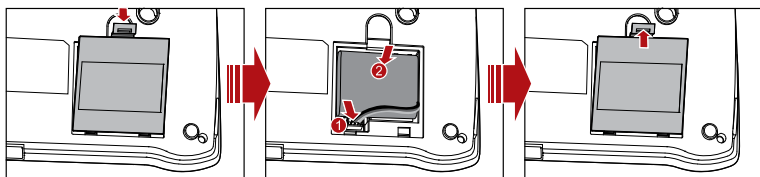

Using the Power Adapter and Charging the Battery

Connect one end of the power adapter cable to the FWT and the other to the power socket.

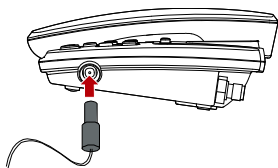









Note:



- Remove the battery if the FWT is left unused for a long period.
- If the battery has not been used for a long time or the battery is exhausted, the screen of the FWT may not function when you charge the battery again. This is normal. After the battery is being charged for a while, you can power on the FWT for use.

- In normal conditions, the FWT depends on the power adapter for power supply and will use the battery only in the case that the electricity has failed and the power adapter is unavailable. As the battery can supply power only for a limited period, you must make sure that the battery has been fully charged before putting it into use.



Using the Menu

1. In standby mode, press  to display the main menu.
2. Press  /  to select a menu item.
3. Press  to display submenu.
4. Access the submenu in either of the ways:
 - Press  /  to scroll to a submenu item and press  to access it.
 - Press the number key corresponding to the number of a submenu to access it.
5. Press  to return to the previous menu or return to the home screen.
6. Press  to return to the standby mode.





Making a Call



1. In standby mode, enter a phone number.
2. Press  to dial the number.
3. Press  to end the call.

Note:

- In standby mode, press  to view the call history. Select a record and press  to dial this number.
- Select a phone number from the phonebook and press  to call this contact.

Answering a Call

When there is an incoming call, press , ,  or pick up the handset to answer it. Press  to reject it.



If the any-key answer function is activated, you can press any key except  and  to answer an incoming call.

Setting the Quiet Mode

- Method 1: In standby mode, press and hold the * key to activate/deactivate the quiet mode.
- Method 2: Choose **Menu > Profiles > Quiet** to activate the quiet mode./





Creating a Message

1. Choose **Menu > Messages > Write Message**.
2. Write the message.

3. Press  to select **Send** or **Send&Save**.
4. Insert recipients. Do the following:
 - Enter the phone number directly.
 - Insert a contact from the phone book.
 - Insert group.
5. Press  to send a message.

Viewing a Message



The inbox stores received messages.

1. Select **Menu > Messages > Inbox**.
2. Press  /  to scroll the messages.
3. Press  to view the message.
4. Press  to reply, delete, or forward a short message, or call or save the phone number of a message.

Changing Text Input Modes

In editing mode, the current text input mode is displayed. Press the **#** key to change the input mode.

Note:

- In the editing mode, press  once to delete the letter on the left of the cursor. Press and hold  to delete all the entered letters.
- In the "ABC" "Abc" or "abc" input mode, press **0** once to enter a space, press **0** for two consecutive times to enter a "0", and press **0** for three consecutive times to start a new line.
- In the "ABC" "Abc" or "abc" input mode, press **1** repeatedly to select and enter the commonly used punctuations.

Entering English (ABC, Abc or abc)



In "ABC" "Abc" or "abc" input mode, press number keys to enter English letters.

If the letter you want to enter is on the same key as the previous one, you can enter the letter only after the cursor appears again or after you move the cursor to the next space.

If you hope the initial letter is capitalized, you need to change the input mode into "Abc" manually before you enter the word.

Intelligent Input (eZiEn)



In "eZiEn" input mode, press number keys to enter English words.

1. According to the word to be entered, press the corresponding number keys once, and the FWT makes out the candidate words.
2. Press  /  or press * repeatedly to select the word.
3. Press  to confirm your selection. The word is displayed in the input area. Alternatively, press the **0** key to confirm your selection and enter a space behind the word.

Entering Numbers



In the "123" input mode, press a key labeled with the desired number.

Entering Symbols

1. In any input mode, press the * key to display a symbol list.
2. Press  /  to scroll up or down the symbol list.
3. Press the corresponding number key to enter the symbol.

Using the Voice Caller ID Function (Optional)

You can use the **Voice Caller ID** function so that you can hear a voice caller ID when there is an incoming call.

1. Select **Menu > Settings > Call Settings > Voice Caller ID**.
2. Press  /  to enable or disable the **Voice Caller ID** function.



Using the Recorder (Optional)

You can use the recorder so that the FWT can automatically answer an incoming call and record the voice of a caller.

Note:

- When the FWT is recording the voice of the caller, you can press  to answer the call. In this case, the FWT stops recording without saving the recorded clip.
- When the list of recorded clips is full, the FWT automatically deletes old clips.



Playing a Recorded Clip

1. Select **Menu > Recorder > Guest Announcements**.
2. Press  /  to select the recorded clip.
3. The FWT automatically plays the recorded clip.

Enabling or Disabling the Recorder



1. Select **Menu > Recorder > Recorder Settings > Recorder On/Off**.
2. Press  /  to enable or disable the recorder.

Setting the Auto Answer Function

1. Select **Menu > Recorder > Recorder Settings > Auto Answer**.
2. Press  /  to select the interval between the ringing of the FWT and the automatic answer of the phone.

Enabling or Disabling the Recording Monitoring Function

When the FWT is recording the voice of a caller, you can listen to the recording and determine whether to answer the call.

1. Select **Menu > Recorder > Recorder Settings > Recording Monitoring**.
2. Press  /  to enable or disable the **Recording Monitoring** function.

FWT Lock

The FWT lock protects your FWT from unauthorized use. The default FWT lock code is 000000. You

can change it into any numeric string of 4 to 8 digits.

When the FWT is locked, enter the lock code to unlock the FWT first; otherwise, you can only make emergency calls or answer calls.

PIN and PUK (Optional)

The personal identity number (PIN) protects your UIM card from unauthorized use. The PIN unblocking key (PUK) can unblock the blocked PIN. If you enter wrong PIN codes for multiple times, your UIM card is locked. In this case, you need to enter the PUK code to unlock the UIM card. Both the PIN and PUK are delivered with the UIM card. For details, consult your service provider.

Keypad Lock

In standby mode, press and hold the # key to lock the keypad.

In standby mode, press  and then press the * key to unlock the keypad.

In standby mode, if the automatic keypad lock function is enabled and the standby time exceeds the preset period, the keypad will be automatically locked.

Warnings and Precautions

This section contains important information pertaining to the operating instructions of your device. It also contains information about how to use the device safely. Read this information carefully before using your device.

Electronic Device

Power off your device if using the device is prohibited. Do not use the device when using the device causes danger or interference with electronic devices.

Medical Device

- Follow rules and regulations set forth by hospitals and health care facilities. Do not use your device when using the device is prohibited.
- Pacemaker manufacturers recommend that a minimum distance of 15 cm be maintained between a device and a pacemaker to prevent potential interference with the pacemaker. If you are using a pacemaker, use the device on the opposite side of the pacemaker and do not carry the device in your front pocket.
- Some wireless devices may affect the performance of hearing aids. For any such problems, consult your service provider.

Potentially Explosive Atmosphere

Power off your device in any area with a potentially explosive atmosphere, and comply with all signs and instructions. Areas that may have potentially explosive atmospheres include the areas where you would normally be advised to turn off your vehicle engine. Triggering of sparks in such areas could cause an explosion or a fire, resulting in bodily injuries or even deaths. Do not power on your device at refueling points such as service stations. Comply with restrictions on the use of radio equipment in fuel depots, storage, and distribution areas, and chemical plants. In addition, adhere to restrictions in areas where blasting operations are in progress. Before using the device, watch out for areas that have potentially explosive atmospheres that are often, but not always, clearly marked. Such locations include areas below the deck on boats, chemical transfer or storage facilities, and areas where the air contains chemicals or particles such as grain, dust, or metal powders. Ask the manufacturers of vehicles using liquefied petroleum gas (such as propane or butane) whether this device can be safely

used in their vicinity.

Traffic Security

- Do not use your device while driving, and observe the local laws and regulations.
- Do not use your device while flying in an aircraft. Power off your device before boarding an aircraft. Using wireless devices in an aircraft may cause danger to the operation of the aircraft and disrupt the wireless telephone network. It may also be considered illegal.

Operating Environment

- Do not use or charge the device in dusty, damp, and dirty places or places with magnetic fields. Otherwise, it may result in a malfunction of the circuit.
- On a stormy day with thunder, do not use your device, to prevent any danger caused by lightning.
- When you are on a call, do not touch the antenna. Touching the antenna affects the call quality and results in increase in power consumption. As a result, the talk time and the standby time are reduced.
- Use accessories authorized by the manufacturer. Using unauthorized accessories will render the warranty null and void.
- Because the device needs to disperse heat during working, place the device and the power supply in a ventilated and shady place. Never cover the device, put objects on it, or place it near water, fire as well as inflammable and explosive materials.
- The antenna(s) used for this transmitter must be installed by keeping a minimum distance of 20 cm from all persons.
- Keep the ambient temperature between -10°C and 45°C while the device is being charged. Keep the ambient temperature between -10°C to 55°C for using the device powered by a battery.

Safety of Children

Comply with all precautions with regard to children's safety. Letting the child play with your device or its accessories, which may include parts that can be detached from the device, may be dangerous, as it may present a choking hazard. Ensure that small children are kept away from the device and accessories.

Accessories

Use the accessories delivered only by the manufacturer. Using accessories of other manufacturers or vendors with this device model may invalidate any approval or warranty applicable to the device, result in the non-operation of the device, and cause danger.

Battery and Charger

- Unplug the charger from the electrical plug and the device when not in use.
- Do not connect two poles of the battery with conductors, such as metal materials, keys, or jewelries. Otherwise, the battery may be short-circuited and may cause injuries and burns on your body.
- Do not disassemble the battery or solder the battery poles. Otherwise, it may lead to electrolyte leakage, overheating, fire, or explosion.
- If battery electrolyte leaks out, ensure that the electrolyte does not touch your skin and eyes. When the electrolyte touches your skin or splashes into your eyes, wash your eyes with clean water immediately and consult a doctor.
- If there is a case of battery deformation, color change, or abnormal heating while you charge or store the battery, remove the battery immediately and stop using it. Otherwise, it may lead to battery leakage, overheating, explosion, or fire.
- If the power cable is damaged (for example, the cord is exposed or broken), or the plug loosens, stop using the cable at once. Otherwise, it may lead to an electric shock, a short circuit of the charger, or a fire.
- Do not dispose of batteries in fire as they may explode. Batteries may also explode if damaged.

Cleaning and Maintenance

- The device, battery, and charger are not water-resistant. Keep them dry. Protect the device, battery, and charger from water or vapor. Do not touch the device or the charger with a wet hand. Otherwise, it may lead to a short circuit, a malfunction of the device, and an electric shock to the user.
- Do not place your device, battery, and charger in places where they can get damaged because of collision. Otherwise, it may lead to battery leakage, device malfunction, overheating, fire, or explosion.
- Do not place magnetic storage media such as magnetic cards and floppy disks near the device. Radiation from the device may erase the information stored on them.
- Do not leave your device, battery, and charger in a place with an extreme high or low temperature. Otherwise, they may not function properly and may lead to a fire or an explosion.
- Do not place sharp metal objects such as pins near the earpiece. The earpiece may attract these objects and hurt you when you are using the device.
- Before you clean or maintain the device, power off the device and disconnect it from the charger.
- Do not use any chemical detergent, powder, or other chemical agents (such as alcohol and benzene) to clean the device and the charger. Otherwise, parts of the device may be damaged or a fire can be caused. You can clean the device and the charger with a piece of damp and soft antistatic cloth.
- Do not dismantle the device or accessories. Otherwise, the warranty on the device and accessories is invalid and the manufacturer is not liable to pay for the damage.

Emergency Call

You can use your device for emergency calls in the service area. The connection, however, cannot be guaranteed in all conditions. You should not rely solely on the device for essential communications.

FCC Statement

This equipment has been tested and found to comply with the limits for a Class B digital device, pursuant to Part 15 of the FCC Rules. These limits are designed to provide reasonable protection against harmful interference in a residential installation. This equipment generates, uses and can radiate radio frequency energy and, if not installed and used in accordance with the instructions, may cause harmful interference to radio communications. However, there is no guarantee that interference will not occur in a particular installation. If this equipment does cause harmful interference to radio or television reception, which can be determined by turning the equipment off and on, the user is encouraged to try to correct the interference by one or more of the following measures:

--Reorient or relocate the receiving antenna.

--Increase the separation between the equipment and receiver.

-- Connect the equipment into an outlet on a circuit different from that to which the receiver is connected.

-- Consult the dealer or an experienced radio/TV technician for help.

This device complies with Part 15 of the FCC Rules. Operation is subject to the following two conditions: (1) this device may not cause harmful interference, and (2) this device must accept any interference received, including interference that may cause undesired operation.

Warning: Changes or modifications made to this device not expressly approved by Huawei Technologies Co., Ltd. may void the FCC authorization to operate this device.