









HUAWEI M750







CDMA Mobile Phone

User Guide

Safety Precautions

Before using the phone, read safety precautions and inform your children about using the phone correctly and safely. For details, see "Warnings and Precautions".

	Do not switch on your phone when using the phone is prohibited or when using the phone may cause interference or danger.		Do not place your phone or the accessories in containers with strong electromagnetic field.
	Do not use your phone while driving.		Do not place magnetic storage media near your phone. Radiation emitted from the phone may erase the information stored on the magnetic storage media.
	Follow the rules or regulations set forth by the hospitals and health care facilities. Switch off your phone near medical apparatus.		Do not place your phone near a high-temperature area. Do not place your phone where it can come in contact with flammable gas such as a gas station.

	<p>Switch off your phone in an aircraft. The phone may cause interference to control signals of the aircraft.</p>		<p>Keep your phone and its accessories away from children. Do not allow children to use your phone without guidance.</p>
	<p>Switch off your phone near high-precision electronic devices. The phone may affect the performance of these devices.</p>		<p>Use only the approved batteries and chargers to avoid explosion.</p>
	<p>Do not attempt to disassemble your phone or its accessories. Only qualified personnel are allowed to service or repair the phone.</p>		<p>Observe the laws or regulations on using the phone. Respect others' privacy and legal rights when using your phone.</p>

Copyright © Huawei Technologies Co., Ltd. 2009. All rights reserved.

No part of this document may be reproduced or transmitted in any form or by any means without prior written consent of Huawei Technologies Co., Ltd.

The product described in this manual may include copyrighted software of Huawei Technologies Co., Ltd and possible licensors. Customers shall not in any manner reproduce, distribute, modify, decompile, disassemble, decrypt, extract, reverse engineer, lease, assign, or sublicense the said software, unless such restrictions are prohibited by applicable laws or such actions are approved by respective copyright holders under licenses.

Trademarks and Permissions



HUAWEI, HUAWEI, and  are trademarks or registered trademarks of Huawei Technologies Co., Ltd.

Other trademarks, product, service and company names mentioned are the property of their respective owners.

Notice

Some features of the product and its accessories described herein rely on the software installed, capacities and settings of local network, and may not be activated or may be limited by local network operators or network service providers, thus the descriptions herein may not exactly match the product or its accessories you purchase.

Huawei Technologies Co., Ltd reserves the right to change or modify any information or specifications contained in this manual without prior notice or obligation.

NO WARRANTY

THE CONTENTS OF THIS MANUAL ARE PROVIDED “AS IS”. EXCEPT AS REQUIRED BY APPLICABLE LAWS, NO WARRANTIES OF ANY KIND, EITHER EXPRESS OR IMPLIED, INCLUDING BUT NOT LIMITED TO, THE IMPLIED WARRANTIES OF MERCHANTABILITY AND FITNESS FOR A PARTICULAR PURPOSE, ARE MADE IN RELATION TO THE ACCURACY, RELIABILITY OR CONTENTS OF THIS MANUAL.

TO THE MAXIMUM EXTENT PERMITTED BY APPLICABLE LAW, IN NO CASE SHALL HUAWEI TECHNOLOGIES CO., LTD BE LIABLE FOR ANY SPECIAL, INCIDENTAL, INDIRECT, OR CONSEQUENTIAL DAMAGES, OR LOST PROFITS, BUSINESS, REVENUE, DATA, GOODWILL OR ANTICIPATED SAVINGS.

Import and Export Regulations

Customers shall comply with all applicable export or import laws and regulations and will obtain all necessary governmental permits and licenses in order to export, re-export or import the product mentioned in this manual including the software and technical data therein.

Conventions

Term Conventions

This manual refers to HUAWEI M750 CDMA mobile phone as "the phone" or "your phone".

Operation Conventions

Operation	Meaning
Press and hold	Press a key for two to three seconds and then release it.
Press	Press a key and release it quickly.

GUI Conventions

Format	Meaning
Bold	Any string displayed on the phone screen is in boldface, such as " Menu ".
>	Multi-level menus are separated by ">". For example, " Menu > Messages " indicates " Messages " is the submenu of " Menu ".

Symbols



Symbol	Description	Meaning
	Caution	Warnings and precautions for operations
	Note	Complementary descriptions for operations

Table of Contents

1 Getting to Know Your Phone	1
Your Phone	1
Keys and Functions	3
Screen Icons	5
Interfaces	6
2 Getting Started	7
Charging the Battery.....	7
Powering On/Off the Phone.....	7
Using the Stylus.....	8
Dragging and Flicking	8
Standby Screen.....	9
3 Voice Services	11
Making a Call.....	11
Answering a Call	11
Operations During a Call.....	12
4 Text Entry	14
On-Screen Keyboard Mode	14
5 SMS.....	15
Writing and Sending a Message	15
Reading a Message	16
6 MMS.....	17
Writing and Sending a Multimedia Message.....	17
Receiving a Multimedia Message.....	17
Viewing a Multimedia Message	18

7 Contacts	19
Adding a Contact.....	19
Searching for a Contact	19
8 @metro	21
Accessing @metro.....	21
Changing Your @metro Settings	22
Using On-line Help	22
9 Alarm Clock	25
Enabling an Alarm Clock	25
Disabling an Alarm Clock	25
10 Music Player	26
Adding a Playlist	26
Playing Music.....	26
11 Camera	30
Taking a Picture.....	30
Viewing a Picture	31
Taking Pictures Sequentially	32
Taking a Picture in Self-Timer Mode	33
Setting a Picture Effect.....	33
12 Security	34
Enabling or Disabling the Phone Lock.....	34
Changing the Phone Lock Code	34
Locking the Keypad	34
13 Bluetooth Connection	36
Sending Data Through a Bluetooth Connection	36
Receiving Data Through a Bluetooth Connection	37
Listening to Music Through a Bluetooth Stereo Headset	38

Sending a Contact Through a Bluetooth Connection.....	39
Other Bluetooth Operations.....	39
14 TTY Operation	41
Using the TTY Device.....	41
Setting the TTY Mode	41
15 Troubleshooting.....	42
16 Warnings and Precautions	44
17 Huawei Technologies Co., Ltd. Limited	
Warranty.....	54

1 Getting to Know Your Phone



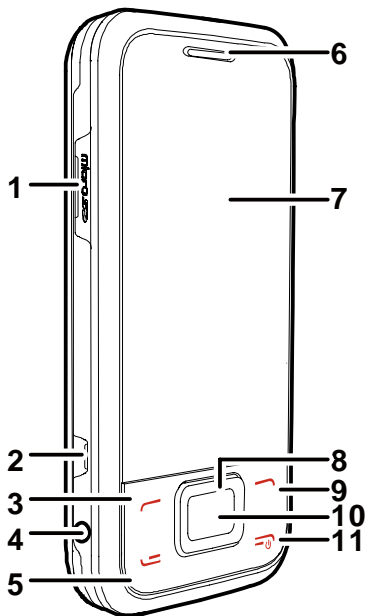

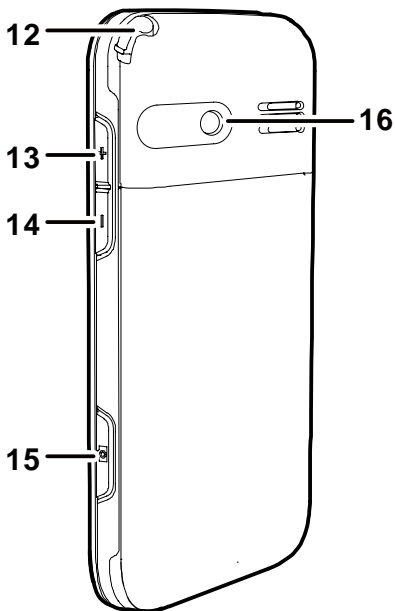



Your Phone























1	microSD Slot	9	Right Soft Key
2	Charger Interface/ Data Cable Connector	10	OK Key
3	Left Soft Key	11	End/Power Key
4	Headset Jack	12	Stylus Pen
5	Talk/Send Key	13	Volume Up Key
6	Earpiece	14	Volume Down Key
7	Screen	15	Camera Key
8	Navigation Keys	16	Camera





Keys and Functions

Press ...	To ...
	<ul style="list-style-type: none"> • Access the All Calls menu in standby mode. • Dial a number or answer a call.
	<ul style="list-style-type: none"> • Power on or power off the phone by pressing and holding the key. • End a call or reject a call. • Return to the standby screen. • Turn on or turn off the screen backlight in standby mode.
	<ul style="list-style-type: none"> • Access Contacts in standby mode. • Select the option displayed in the lower left corner of the screen.
	<ul style="list-style-type: none"> • Access @metro in standby mode. • Select the option displayed in the lower right corner of the screen.
	<ul style="list-style-type: none"> • Launch the camera in standby mode by pressing and holding the key. • Take a picture after the camera is launched.
	<ul style="list-style-type: none"> • Access Menu in standby mode. • Confirm a selection in menu mode. • Start playing music after the music player is launched.
	Increase the volume during a call or music playing.
	Decrease the volume during a call or music playing.

Press ...	To ...
	 : Access Contacts in standby mode; increase the volume during a call.
	 : Access the Messages menu in standby mode; access the screen for writing a message by pressing and holding the key; decrease the volume during a call.
	 : Access Metro WEB in standby mode; decrease the volume during a call.
	 : Access @metro in standby mode; increase the volume during a call.

Screen Icons

Icon	Description
	Indicates the signal strength. The more the bars are, the stronger the signal is.
	There is an incoming call; a call is being set up; or the phone is in conversation.
	The voice privacy function is enabled.
	The phone is in the roaming status.
	A new message is received.
	The memory for messages is full.
	An urgent message is received.
	A new voice mail is received.
	A new PUSH message is received.
	A new MMS is received.
	MicroSD Card.
	The AGPS indicator mode is Location On .
	The alert type is Ring .
	The alert type is Ring & Vibration .

Icon	Description
	The alert type is Vibration .
	The alert type is Silence .
	An alarm clock is set.
	Indicates the battery power level. The more the bars are, the higher the remaining battery level is.
	The battery power level is extremely low.

Interfaces

Interface	Description
Charger interface /Data cable connector	It is at the right side of your phone. You can connect the travel charger or data cable to it.
Headset jack	It is at the right side of your phone. You can connect the headset to it.

2 Getting Started

Installing the Battery

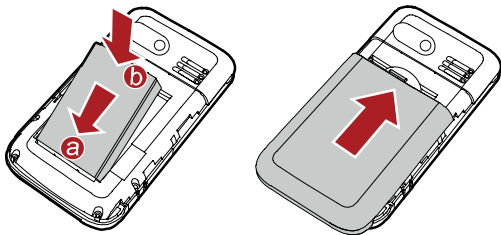

Charging the Battery

To charge the battery, do as follows:

1. Connect the travel charger to the charger interface at the bottom of your phone.
2. Connect the charger to an AC power socket.
During the charging process, the icon on the upper right corner of the screen is in an animated status.
3. Wait until the phone is completely charged.
If the icon becomes static, the battery is completely charged.
4. Disconnect the charger from the AC power socket.
5. Disconnect the charger from the phone.



- Do not use a damaged battery or charger.
- Before using the travel charger, ensure that the battery is installed in your phone.

Powering On/Off the Phone

To power on the phone, press and hold  until the screen backlight is on.

To power off the phone, press and hold  until the power-off prompt is displayed.

Using the Stylus

You can use the stylus to select an item or enter text by tapping on the touch screen of your phone.

■ Stylus Operations

To perform an operation with the stylus, you can do as follows:

- Tap: Select an item or display a menu by touching the stylus to the screen.
- Drag: Select multiple characters in on-screen keyboard mode or move an object by moving the stylus on the screen.

■ Screen Calibration

When operating the phone with the stylus, if the phone cannot respond to your operation correctly, you can calibrate the screen as follows:

- Select **Menu > Settings > Display Settings > Screen Calibration** to access the screen for calibration.
- Calibrate the screen by tapping the center of + displayed on the screen according to the instructions.

 During the calibration, tap the center of + accurately, to ensure that the phone can respond to your tap and text entry on the screen correctly after the calibration.

Dragging and Flicking

On following screens, you can perform some operations conveniently through dragging on the touch screen:



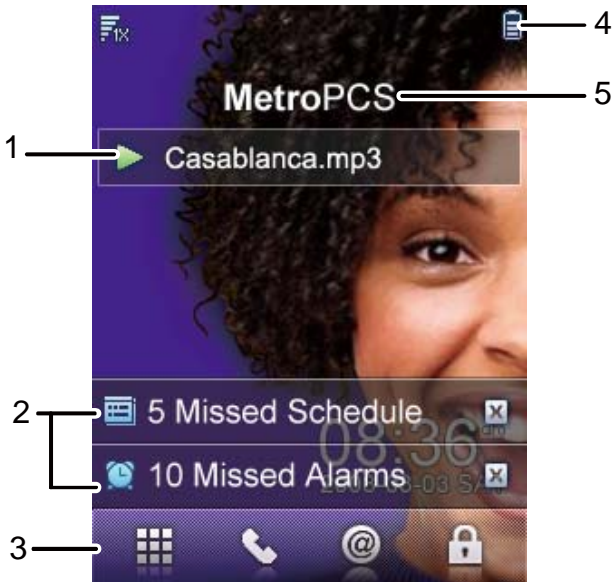

- On the standby screen, tap and drag the title, clock, or date to change the position of the selected item.
- In the menu list, drag up or down to scroll. Then tap a submenu to select it.

- When viewing pictures, flick right or left to switch a picture to the next or previous one.
- 📖 The resolution of the phone screen is 240×320 . Therefore, when viewing pictures, a picture with a resolution higher than 240×320 may be displayed improperly.

Standby Screen



Description

- 1
 - The information about the playing music player is displayed.
 - Tap this area to access the music player.
- 2
 - The notifications such as the information about missed calls and new messages are displayed.
 - Tap this area to view the details.
 - Tap  to close a notification bar.
- 3
 - Tap  to access **Menu**.
 - Tap  to access the dialer.
 - Tap  to access **@metro**.
 - Tap  to lock the keypad.
- 4





The icons indicating the status, such as the signal strength, battery level, and current profile are displayed.
- 5
 - By default, the name of the network operator is displayed. You can tap it to set a customized title.
 - Select **Menu > Settings > Display Settings > Banner** to change the title content.





To prevent the slow response of the system, you are recommended not to set a picture in the GIF format as the wallpaper.







3 Voice Services



Making a Call

1. In standby mode, tap  to access the dialer.
2. Enter the phone number on the dialer.
 - For international calls, tap * twice consecutively to enter the plus sign (+). Then enter the country or region code, area code, and phone number in sequence.
 - For extension numbers, enter the phone number, tap * three or four times consecutively to enter **P** or **T**, and then enter the extension number.
3. Press  or tap  to dial the number.
4. Press  or tap  to end the call or cancel the dialing.

 In standby mode, you can press  to view call logs. Then select a number and press  to dial the number.

Answering a Call

When there is an incoming call, you can press  or , or tap  to answer the call; tap  to silence the phone; press  or tap  to reject the call.

- When the any-key answer function is enabled, you can press any key (except  and ) to answer the call.
- When the **Headset Auto Answer** function is enabled and the headset is properly connected to the phone, the phone answers the call automatically.
- The **Headset Auto Answer** function is available only when a wired headset is used.

-  You can set the any-key answer function in the **Settings > Call Settings > Answer Mode**, and set the headset auto-answer function in the **Settings > Call Settings > Headset Auto Answer**.

Operations During a Call

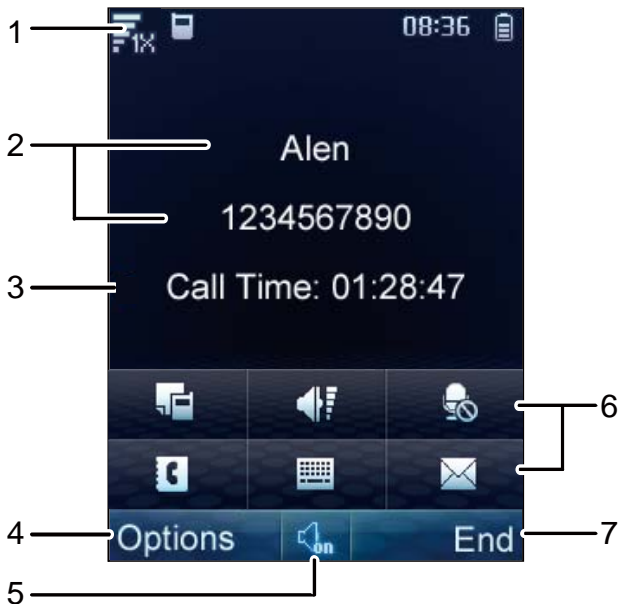

Description

- 1 The icons indicating the status, such as the signal strength, battery level, and current profile, and the current time are displayed.

Description



2 The contact name and the number of an ongoing call are displayed.

3 Call duration is displayed.





Select **Options** for the following options:

- **Mute:** Mute the microphone.
 - **Save Number:** Save the number to **Contacts**.
 - **Use Bluetooth Headset:** Use bluetooth headset.
- 4
- **Contacts:** Search for or create a contact.
 - **Messages:** Access the **Messages** menu.
 - **Call Memo:** Write information during a call.
 - **Voice Privacy:** Enable voice encryption.
 - **TTY Setup:** Setting the TTY mode.
-

5 Tap this icon to switch between the hands-free mode and the hand-held mode.

- Tap  to access the **Call Memo** menu.
- Tap  to access the screen for adjusting the volume.

6

- Tap  mute the microphone.
- Tap  to access the **Contacts** menu.
- Tap  to display the on-screen keyboard.
- Tap  to access the **Messages** menu.

7 Select **End** to end the call.

4 Text Entry

On-Screen Keyboard Mode

In on-screen keyboard mode, the following bar is displayed at the bottom of the screen.



Description

- 1 On-screen keyboard: Tap keys on the keyboard to enter letters, numbers, or symbols.
- 2 Text input modes: Tap **Sp**, **ABC**, **123**, or **SYM** to enter letters, numbers, or symbols through the on-screen keyboard.

You can tap keys on the on-screen keyboard to enter corresponding letters, numbers, or symbols.





Writing and Sending a Message

To write and send a text message, do as follows:

1. Select **Menu > Messages > SMS > Create Message**, or press and hold .

2. Write a message and then select **Options** for the following options:

- **Send:** Send the message.
 - **Save:** Save the message to **Drafts**.
 - **Insert Quick Text:** Insert a commonly used phrase into the message.
 - **Insert Contact:** Select a contact from the phonebook and insert the phone number into the message.
 - **Insert Special Symbol:** Insert a preset website-related symbol into the message.
 - **Priority:** Set the message priority that can be **Normal**, **Interactive**, **Urgent**, or **Emergency**.
 - **Callback Number:** Set the callback number. The callback number will be sent to the message recipient with the message. You can set it to either your phone number or another number. After receiving your message, the recipient can call you back through the callback number.
3. Select **Options > Send** or tap  to add the recipient(s) of the message. Up to 100 recipients can be added by using one of the following methods:
 - Enter the phone number(s) of the recipient(s) directly.

- Select **Search** > **Contacts** or tap  to select the recipients from the phonebook.
 - Select **Search** > **Groups** or tap  to select a group of recipients.
4. Press  or tap  to send the message

Reading a Message

Inbox stores the received text messages. To read a text message in the inbox, do as follows:

1. Select **Menu** > **Messages** > **SMS** > **Inbox**.
2. Select **Options** > **View** or tap  to select and read the desired message.
3. Select **Options** for the following options:
 - **Reply**: Write a new text message to reply to the message sender.
 - **Delete**: Delete the message.
 - **Forward**: Forward the message.
 - **Extract**: Extract the number(s) contained in the message.
 - **Extract URL**: Extract the URL address(es) contained in the message.

6 MMS

Writing and Sending a Multimedia Message

To write and send a multimedia message, do as follows:

1. Select **Menu > Messages > MMS > Create MMS**.
2. Edit the message by adding contents to the following fields:
 - **Recipient:** Add the recipient(s) of the message. Up to 20 recipients can be added.
 - **Subject:** Enter the subject of the message.
 - **Slides:** Insert pictures, audio files, video files, and text into a slide.
3. After you write the message, select **Options > Send** to send the message.



The MMS function is network dependent. If you cannot send or receive multimedia messages, contact your service provider.

Receiving a Multimedia Message

After you select **Menu > Messages > MMS > MMS Settings > Receive options > Download timing > Manual**, a message notification will be received and saved in the inbox before you receive a multimedia message. Then you need to press  to read the message notification and select **Options > Download** to receive the multimedia message.

After you select **Menu > Messages > MMS > MMS Settings > Receive options > Download timing > Automatic**, the phone will automatically download a multimedia message to the inbox.

Viewing a Multimedia Message

Inbox stores the received multimedia messages. To view a multimedia message in the inbox, do as follows:

1. Select **Menu > Messages > MMS > Inbox**.

2. Press  to select a message.

3. Press  to view the contents of the message.



4. Select **Options** for the following options:

- **Open:** View the contents of the message.
- **Reply:** Write a new multimedia message to reply to the message sender.
- **Reply All:** Write a new multimedia message to reply to the message sender and all other message recipients.
- **Forward:** Forward the message.
- **Move to Folders:** Move the message to **MMS > My Folders**.
- **Delete:** Delete the message.
- **Delete All:** Delete all the messages in the inbox.
- **Sort:** Sort the messages in the inbox according to **Date** or **Address**.
- **Filter View:** List the messages that comply with your specified condition that can be **Show All**, **MMS**, or **High Priority**.

7 Contacts

Adding a Contact

To add a contact to the phonebook, do as follows:

1. Select **Menu > Contacts > Add New**.
2. Enter the information about the contact. Information can be entered in the following fields, including **Name, Mobile Number, Home Number, Office Number, Fax Number, E-Mail, Notes, Custom Tone, Custom Image**, and **URL**. (For each contact, at least one number needs to be entered.)
3. Press  to scroll to the desired field and then press , or directly tap the desired field to select it.
4. Enter the corresponding information with the stylus.
5. Save or cancel the edit of the contact.
 - Select **Save** or tap  to save the contact to the phonebook.
 - Select **Cancel**, and then select **Yes** or **No** to cancel or continue with the edit of the contact.

Searching for a Contact

To search for a contact, do as follows:

1. Select **Menu > Contacts > Search**.
2. Enter the name of the contact. Then select **Search**.
3. After the contact is found, select **Options** for the following options:
 - **View**: View details of the contact.
 - **Edit**: Edit the contact, such as changing the name, number, or other fields of the contact.
 - **Add New**: Add a new contact.

- **Send Message:** Edit and send a text or multimedia message to the contact.
- **Send Via Bluetooth:** Send the contact through Bluetooth.
- **Delete:** Delete the contact.
- **Call:** Call the contact.
- **Edit Before call:** Edit the number before you call it.

8 @metro



With Mobile Shop, you can download full featured applications over the air including games, personalized ring tones, pictures, and more. You can send and receive instant messages and email, or browse the web to catch up on all the latest news.

This section outlines how to obtain games and other applications for your phone. For more information about this function, consult your service provider.

Accessing @metro

■ Applications Shopping and Downloading

Download games, ring tones, e-mail, and more using the **Mobile Shop**. For information on airtime charges, consult your service provider.

1. In the standby mode, press  to launch @metro.
2. Press  to select the **Mobile Shop**, then press . Your phone takes a moment to connect, then the Mobile Shop Catalog menu appears in the display.





 The first time you access the **Mobile Shop**, an "airtime warning" message appears in the display along with instructions on how to remove this message.

3. Follow the instructions in your phone's display.

 Please check with your Wireless Carrier for availability of applications.





Changing Your @metro Settings

Use the **Settings** menu in Mobile Shop to manage, move, order applications, and much more.

1. In the standby mode, press  to launch @metro.
2. At the @metro menu, Press  to select **Settings**, then press . The following options appear in the display:
 - **Order Apps:** Download applications over the network.
 - **Move Apps:** Move previously downloaded applications between available folders.
 - **Manage Apps:** View used and available memory.
 - **Main Menu View:** Select whether you wish to view the main **Mobile Shop** menu in a list or icon format.
 - **View Log:** View the Mobile Shop log, which displays information about recent activity using Mobile Shop.
3. Press  to select the desired option.
4. Press  to enter the option's sub-menu and view or change settings.

Using On-line Help

The Help sub-menu within @metro is a short tutorial on several @metro-Mobile Shop features. View information about charges, cancelling subscriptions, buying apps, disabling apps, and more.

1. Within in the @metro menu, use  to select **Help**.
2. Press . The Help subjects described in the following subsections appear in the display.
3. Use  to select the desired Help subject.
4. Press  to view the selected Help information.

■ Buying New Apps

To buy new and exciting apps, visit the Mobile Shop. It provides you with a variety of apps you can choose from.

■ What do I pay?

When you buy an app, you will be charged for the purchase cost of the app.

■ Demo Apps

A Demo app is free and is designed to demonstrate the app's main features. It usually expires after a certain period of time or a number of uses and often has limited functions. When you run a demo app, you will be presented with a purchase option so you won't have to look for the app in the Mobile Shop.

■ Removing Apps

You may remove apps that are no longer needed. When you remove an app, you cannot use the application unless you purchase it again. To remove an app, choose **Settings > Manage Apps**. Then, select the app you want to remove.

■ Disabled Apps

You can install new apps even if the memory of your phone is full by partially removing (disabling) apps you haven't used recently. When you need to use a disabled app, you can restore it at no additional purchase cost.

■ Restoring Apps

Disabled apps can be quickly restored at no additional purchase cost. To restore an app, run the application you want to restore from the Main Menu. You will be guided through the restoration process.



■ Expired Apps

Apps that were purchased based on the number of uses or for a specified period of time expire. You can purchase additional uses from the Mobile Shop.

9 Alarm Clock

After an alarm clock is enabled, the phone notifies you at a preset time if the phone is powered on. You can set up to five alarm clocks.

Enabling an Alarm Clock

1. Select **Menu** > **Tools** > **Alarms**.
2. Select an alarm clock, select **Edit**, and then press  or tap  to set the title, time, alert cycle (days), and alert tone of the alarm clock.
3. Select **On** to enable the alarm clock.
4. Select **Save** to save the settings of the alarm clock.
 -  • When an alarm clock alerts, select **Stop** to stop it or select **Snooze** to snooze it for five minutes.
 - If you perform no operation to an alarm clock that alerts, the alarm clock stops temporarily after 45-second ringing and alerts again five minutes later. The alarm clock alerts five times before it stops thoroughly.
 - After selecting **Cycling** > **Custom**, you can select the days on which an alarm clock needs to repeat from the seven days in a week.

Disabling an Alarm Clock







1. Select **Menu** > **Tools** > **Alarms**.
2. Select an alarm clock. Then select **Off** to disable the alarm clock, or select **Cancel All** to disable all alarm clocks.

10 Music Player

Adding a Playlist





1. In standby mode, select **Menu > Multimedia > Add New Playlist** to add a new playlist.
2. Enter the name of the playlist, and then select **Save** to save it.
3. Select **Add** to add songs to the playlist.









 If a playlist has been saved on the phone, you need to move the cursor to the playlist, and then select **Options > Add New Playlist** to add a new playlist. You can select **From My File** or **From Playlist** to add songs to the new playlist.

4. Press  or tap  (or ) to select a storage location: phone or microSD card.
5. Press  to scroll through the songs. Then press  or tap to select a song and add it to the playlist. (Press  again or tap to remove the song from the playlist.)
6. Select **Options > Add** to save the playlist.

Playing Music

In standby mode, select **Menu > Music player > Music NOW!** to launch the music player.

- Press  to play a song. During playback of a song, you can press  to pause the song; press it again to resume playback.
- Press  to play the next track; press  to play the previous track.

- During playback of a song, press and hold  to fast-forward the song; press and hold  to rewind the song.
- Press  to access the current playlist.
- Press  or  to increase or decrease the volume.
- Press  to stop playing a song.
- Press  to return to the standby screen. Then the music player plays the song at the background. The screen displays the name of the current song on the status bar of the music player. You can tap the status bar to access the music player again, or tap  (or ) to pause or resume playback.



You can also control the music player through tapping the icons on the player screen.



	Description
1	Title bar, displaying the name and the number of the current song.
2	Time bar, displaying the total time and the played duration of a song.

Description







Shortcut icons. You can perform the following operations:

- 3
 - Tap  to set the phone to repeat all songs in a playlist, to repeat the current song, or not to repeat songs.
 - Tap  to set the phone to play songs in order or to shuffle songs.
 - Tap  to switch between the settings of the equalizer.

4 Options menu.

- 5 Progress slider, displaying the playing progress of the current song. You can drag the progress slider to the point that you want the file to play.

Playback control icons. You can perform the following operations:

- 6
 - Tap  to access the current playlist.
 - Tap  to stop playing a song.
 - Tap  to pause the song; tap  to resume playback.
 - Tap  to play the previous track.
 - Tap  to play the next track.

- 7 Volume control slider. You can drag the slider to adjust the volume.

- 8
 - When the music player is playing a song, select **Minimize** to minimize the music player and return to the previous menu.
 - When the music player is stopped, select **Minimize** to close the music player and return to the previous menu.
-

11 Camera

Taking a Picture

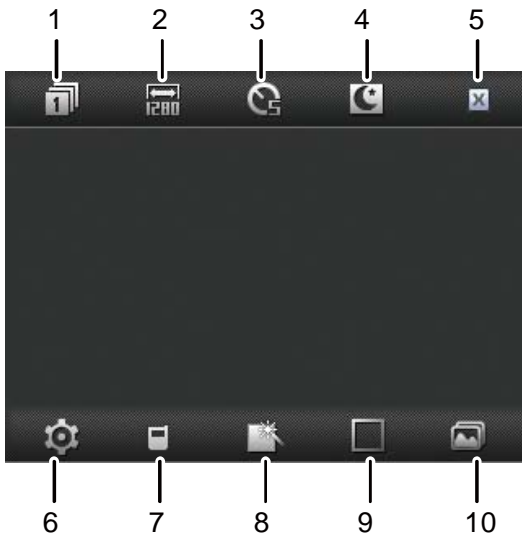

1. In standby mode, select **Menu > Camera** or press and hold  to launch the camera.







Description

- | | |
|---|--|
| 1 | Capture modes: Tap the icon to select a capture mode. |
| 2 | Resolutions: Tap the icon to switch between picture resolutions. |
| 3 | Self-timer mode: Tap the icon to set the time delay of |



	Description
	taking a picture after the shutter release.
4	Night mode: Tap the icon to enable or disable the night mode.
5	Back: Tap the icon to return to the previous menu.
6	Settings: Tap the icon to access the setting menu.
7	Location: Save location
8	Effects: Tap the icon to switch between the picture effects.
9	Frames: Tap the icon to switch between fun frames.
10	Album: Tap the icon to access the album.









2. Focus the camera on the scene and press  or  to take a picture. Then you can preview the picture and save it.

- Tap  to delete the picture.
- Tap  to set the picture as the wallpaper or a contact image.
- Tap  to send the picture through the MMS or Bluetooth.
- Tap  to access the album.

 In preview mode, you can drag up or down on the screen to zoom out or zoom in (for the resolutions of 1280 × 1024 and 1280 × 960, the camera can be neither zoomed in nor zoomed out). You can also flick left or right to decrease or increase the brightness.



Viewing a Picture



1. In standby mode, select **Menu** > **Camera**, or press and hold  to launch the camera.
2. Tap  to access the album.

3. Press  or tap  (or ) to select a storage location: phone or microSD card.
4. Press  to select a picture.
5. Tap  or directly tap the desire picture to view it.
 - Press , or flick left or right to switch between the pictures.
 - Tap  or tap the picture to view the picture in full screen mode. Tap the picture again or press  to exit from the full screen mode.
6. Tap **Options** for the following options:
 - **Full Screen:** View the picture in full screen mode.
 - **Slide Show:** Play all pictures as a slide show.
 - **Rotate:** Rotate the picture.
 - **Set as:** Set the picture as the wallpaper or a contact image.
 - **Send:** Send the picture through the MMS or Bluetooth.
 - **Delete:** Delete the picture.
 - **File Info:** View the name, size, creation date, and resolution of the picture.
7. Select **Back** to return to the picture list.



 You can also select **Menu > My Files > Pictures** to select a storage location (phone or microSD card), and then view the corresponding pictures.



Taking Pictures Sequentially



1. In standby mode, select **Menu > Camera**, or press and hold  to launch the camera.
2. Tap  to select to take a succession of four or nine pictures.

3. Focus the camera on the scene and press  or  to take pictures. The phone will take a preset number of pictures sequentially and then save them automatically.



Taking a Picture in Self-Timer Mode

1. In standby mode, select **Menu** > **Camera**, or press and hold  to launch the camera.
2. Tap  to switch between the 5-second and 10-second self-timer modes.

 You can tap  to access the setting menu. Then select **Shot Tone** to enable or disable the self-timer alert tone.

3. Focus the camera on the scene and press  or . Then the phone will take a picture after a preset countdown and then save it automatically.

Setting a Picture Effect

1. In standby mode, select **Menu** > **Camera**, or press and hold  to launch the camera.
2. Tap  to switch between the picture effects.

12 Security

Enabling or Disabling the Phone Lock

The phone lock protects your phone from unauthorized use. By default, the phone lock is not enabled. You can change the default phone lock code (Last four number of the MDN) to any numeric string of four to eight digits.



1. Select **Menu > Settings > Security Settings > Phone Lock**.
2. Select one of the following phone lock modes:
 - **Immediate:** Enable the phone lock immediately.
 - **Power On:** Enable the phone lock when the phone is powered on next time.
 - **Off:** Disable the phone lock.

Changing the Phone Lock Code

Do remember your phone lock code. If you forget it, contact your local dealer.

1. Select **Menu > Settings > Security Settings > Change Phone Code**.
2. Enter the correct phone lock code and select **OK**.
3. Enter the new phone lock code and select **OK**.
4. Enter the new phone lock code again and select **OK**.

Locking the Keypad

When the keypad is locked, you can still answer incoming calls by pressing  or tapping .

■ Manually Locking the Keypad

To avoid misoperations, you can tap  on the standby screen to lock the keypad.

■ Automatically Locking the Keypad

If the auto keyguard function is enabled, after the phone is idle for a preset period of time in standby mode, the keypad is locked automatically.



1. Select **Menu** > **Settings** > **Phone Settings** > **Auto Keyguard**.

2. Select one of the following options:

- **Off**: Disable the auto keyguard function.
- **15 Seconds, 30 Seconds, or 1 Minute**: Set the keypad to be locked after the phone is idle for 15 seconds, 30 seconds, or one minute.

■ Unlocking the Keypad

In standby mode, you can unlock the keypad by using one of the following methods:

1. Drag  in the lower left corner of the screen to the designated position.
2. Press  and then  to unlock the keypad.

13 Bluetooth Connection

Your phone supports Bluetooth wireless connections. Through Bluetooth, you can set up wireless connections between your phone and other Bluetooth-compatible devices to exchange data. Bluetooth wireless connections can be set up between the devices within a maximum range of 10 meters, however, the connections can be disturbed by other electronic devices or blocked by obstacles such as walls.



- In certain areas, the use of Bluetooth devices might be restricted or prohibited. Observe local laws and regulations.
- Do not accept the connection request of an unknown device. Thus you can prevent your mobile phone from the intrusion of harmful contents.

Sending Data Through a Bluetooth Connection

1. To enable the Bluetooth function, select **Menu > Settings > Connectivity Settings > Blue Tooth > Switch On**.
2. Launch the application that saves the contents to be sent. For example, if you want to send a picture to another device, you need to launch the **My Files** application.
3. Select the contents you want to send. Then select **Options > Send > BlueTooth**.

 If the Bluetooth function is not enabled yet, the phone displays "Switch On Bluetooth ?" on the screen.

- Select **Yes** to enable Bluetooth and access **Device List**.
- Select **No** to reject enabling of Bluetooth and return to the previous menu.

4. After accessing **Device List**, you need to select the device to be connected from the list.

-  • You can set up only one Bluetooth connection each time.
- If the device list contains the devices that are already paired with your phone, select the desired device to send data.
 - When the device list is empty or the device to be connected to is not in the list, select **Search** to search for other Bluetooth-enabled devices in the effective range. The names of the found devices will be displayed on the screen. Select **Back** to stop searching.

5. Select **Options** > **Send** to send the contents through Bluetooth. If the other Bluetooth device requires verification before the connection, your phone displays **Input pair password** on the screen. Then create a password that is to be used together with the other party. After both parties enter the same password, the Bluetooth connection can be set up.

6. After the connection is set up, information about the data being transmitted is displayed on the screen.

Receiving Data Through a Bluetooth Connection

1. When another device sends data to your phone through Bluetooth, your phone displays "Accept Bluetooth transfer request?" on the screen. Select **Yes** to receive the data. The

filename and the receiving progress are displayed on the screen. Select **No** to reject the data.

 When your phone sets up a Bluetooth connection with another device for the first time, the phone displays **Input pair password** on the screen for verification. Then enter a password of one to eight digits and select **OK**. After the other party enters the same password, your phone begins to receive data.

2. The phone displays "Receive Success, save to phone" on the screen, indicating that the data is received and saved to **My Files**.

 If a microSD card is installed on your phone, the phone saves the received data to the microSD card by default; otherwise, the phone saves the received data to the phone memory.

Listening to Music Through a Bluetooth Stereo Headset

You can listen to music on the phone through a Bluetooth stereo headset.

1. In standby mode, select **Menu > Music player > Music NOW!** to launch the music player. Then switch on your Bluetooth headset for pairing.
2. Select **Options > Play via BT**.
3. When the phone displays "Switch On Bluetooth?", select **Yes** to access the device list.
4. Select **Search** to search for Bluetooth-compatible devices. In the list of newly found devices, select the corresponding Bluetooth headset. Then select **Options > Send** to access the screen for pairing devices.

5. Enter the password for pairing the Bluetooth headset and select **OK**.
6. After the phone sets up the Bluetooth connection, you can listen to music through the Bluetooth stereo headset.
 -  After your phone is connected to a Bluetooth headset, music, voice broadcast messages, and navigation voice messages are played through the headset.

Sending a Contact Through a Bluetooth Connection

Your phone can send a contact through Bluetooth.

1. In standby mode, select **Options > Contacts > Contacts List** to access the contact list.
2. Select a contact to be sent, and then select **Options > Send Via > Bluetooth**.
3. When the phone displays "Switch On Bluetooth?", select **Yes** to access the device list.
4. Select **Search** to search for Bluetooth-compatible devices. In the list of newly found devices, select the corresponding Bluetooth headset. Then select **Options > Send** to access the screen for pairing devices.
5. Enter the pairing password, and then select **OK**.
6. After the Bluetooth connection is set up, the phone begins to send the contact.

Other Bluetooth Operations

- **Switch On/Off:** Enable or disable the Bluetooth function.
- **Search new device:** Search for Bluetooth-compatible devices.
- **Device List:** View all paired Bluetooth devices.

- **My device properties:** View the name, visibility, hardware address, type, and supported mode of the phone.

14 TTY Operation

Using the TTY Device

The Teletypewriter (TTY) is a typewriting device. By connecting the phone to the TTY device, you can use the TTY functions to send/receive messages.

When you use the TTY function, do as follows:

1. Connect the TTY device to the headset jack of the phone and set the phone to the TTY mode.
2. Make or answer calls as normal.
3. When the call is put through, use the TTY device to send or receive the letters.
4. Press  or select **End** to end the call.

Setting the TTY Mode

1. In standby mode, select **Menu > Settings > Phone Settings > TTY Setup**.
2. Select the **TTY** mode, and then press **Select** or  to confirm.
 - **Voice**: The standard voice speaking mode and the listening mode.
 - **TTY**: Transmit and receive the TTY characters.
 - **VCO**: Receive TTY characters but transmit by speaking into the microphone.
 - **HCO**: Transmit TTY characters but receive by listening to the earpiece.

15 Troubleshooting

If you encounter any problem when using your phone, try to rectify the problem according to the following table. If the problem persists, contact the service provider or the dealer.

Problem	Ensure that...
The battery cannot be charged.	The charger is properly connected to your phone and the power socket.
The phone cannot be powered on.	The battery power is sufficient. The battery is properly installed. Press and hold  .
You cannot make a call except an emergency call.	<ol style="list-style-type: none">1 The phone number is correct.2 You are in the network service area.3 You have not enabled the call restriction function.
Bad call quality.	<ol style="list-style-type: none">1 The signal strength is strong enough.2 If you are staying indoors, move close to a window.
During a call, the other side cannot hear your voice.	The microphone is not covered.
The signal strength is not strong enough or your phone is often off line.	<ol style="list-style-type: none">1 The antenna is in a good condition.2 Move close to a place with strong signal strength.

Problem	Ensure that...
Your phone displays "No service found", "Service unavailable" or "Network problem".	<ol style="list-style-type: none"><li data-bbox="477 157 936 339">1 You are not in an area with weak magnetic field (in a tunnel or surrounded by buildings). If so, move to another area and try again.<li data-bbox="477 339 936 493">2 Do not visit the service option without obtaining authorization from your service provider.

16 Warnings and Precautions

■ Electronic Device

- Power off your phone near high-precision electronic devices. The phone may affect the performance of these devices.
- Pacemaker manufacturers recommend that a minimum separation of 7 inches (20 cm) be maintained between a mobile phone and a pace-maker to avoid potential interference with the pace-maker. To maintain this distance, it is recommended that you use the phone on the opposite ear from your pacemaker and do not carry it in a breast pocket. If you have reason to believe interference is occurring, power off your phone immediately and consult with your physician.
- Some wireless phones may interfere with some hearing aids. In the event of such interference, consult your service provider or consult with your physician. To ensure that the Hearing Aid Compatibility rating for your phone is maintained, secondary transmitters such as Bluetooth and WLAN components must be disabled during a call.

■ Health Care Facilities

Note the following concerning use of your phone in health care facilities:

- Do not take your phone into the operating room (OR), intensive care unit (ICU), or coronary care unit (CCU).
- Do not use your phone in any area of a health care facility where mobile phone use is prohibited.

■ Area with Inflammables and Explosives

In any area with flammables and explosives, power off your phone and do not take out, install or charge the battery, to prevent

explosion and fire. Areas with inflammables and explosives may include, but are not limited to:

- Gas stations
- Areas for storing fuels (such as below deck on a ship)
- Devices/Vehicles transporting and storing fuels or chemical products
- Areas containing chemical substances or particles (such as sand, dust, or metal powder) in the air
- Areas with posted signs warning of "Explosives"
- Areas advising to "Power off bi-direction wireless equipment"
- Any Area where it is recommended to turn off the engine of a vehicle.

■ Traffic Safety

- Please observe federal, state, and local laws and regulations concerning phone use while driving.
- Secure the phone in its holder. Do not place the phone on the seat or other places where it could become loose in a sudden stop or collision.
- Do not place the phone over the air bag or in the air bag deployment area. The phone may cause injury due to the strong force created by the inflating air bag.
- Observe all rules and regulations during air travel. When boarding an airplane, power off the phone and take out the battery. In areas where phone use is prohibited, power-off the phone. The radio signal of the phone may interfere with the airplane's navigation or instrumentation systems.

■ Storage Environment

- Do not place magnetic storage media such as magnetic cards and floppy disks near the phone. Electromagnetic radiation from the phone may erase the information stored on them.

- Do not put your phone, battery, or other accessories in containers with a strong magnetic field, such as an induction oven or a microwave oven. Otherwise, circuit failure, fire, or explosion may occur.
- Do not leave your phone, battery, or charger in a very hot or cold place. Otherwise, malfunction, fire, or explosion may occur.
- Do not place sharp metal objects such as pins near the earpiece. The earpiece emits a magnetic field that may attract objects, causing injury.

■ Operating Environment

- The phone, battery, and charger are not water-resistant. Keep them dry. Protect the phone, battery and charge from water or steam. Do not touch the phone with a wet skin. Otherwise, short-circuit and malfunction of the product or electric shock may occur.
- Do not use the phone in dusty, damp and dirty places or areas with excessive magnetic fields. Otherwise, malfunction of the circuitry may occur.
- The phone meets applicable radio frequency exposure guidelines when used in the normal when positioned at least 1.5 cm away from the body. When a carry pouch or belt clip is used, it should not contain metallic objects, and the phone should be positioned at the above-stated distance from your body.
- Do not subject your phone, battery, and charger to serious collision or shock. Otherwise, battery leakage, phone malfunction, overheating, fire, or explosion may occur.
- If you experience discomfort (such as becoming nauseous or dizzy) after playing games on your phone for long periods of time, consult a physician immediately.
- During electrical storms, do not use your phone outdoors or while it is charging.

- Do not touch the antenna when during a call. Touching the antenna may affect call quality and may cause the phone to expend additional power. As a result, the talk time and standby time may be shortened.
- Use only phone accessories authorized by the manufacturer. Use of unauthorized accessories will void warranty.
- While using the mobile phone, observe all federal, state, and local laws and regulations, and respect others' privacy and legal rights.

■ Child Safety

- Keep your phone, battery, and charger beyond the reach of children. Do not allow children to use the phone, battery, or charger without adult supervision.
- Do not allow children to place batteries in their mouths. The electrolyte in the battery is poisonous.
- Your phone contains small parts with small edges that may cause choking.

■ Clearing and Maintenance

- Before you clean or maintain the phone, power off the phone and disconnect it from the charger. Otherwise, electric shock or short-circuit of the battery or charger may occur.
- Do not use any chemical detergent, powder, or other chemical agent (such as alcohol or benzene) to clean the phone and the charger. Otherwise, damage or fire could occur. Clean the phone and the charger with a piece of soft damp antistatic cloth.
- Keep the plug dry during cleaning to prevent fire.
- If the phone or any of its fittings does not work, return to a local authorized service center for repair.
- Do not dismantle the mobile phone or accessories. Only an authorized service center is allowed to disassemble the mobile phone. Any disassembly of the mobile phone beyond what is

necessary for routine maintenance (such as changing the battery) will void the warranty.

■ Environmental Protection

- Please observe all federal, state, and local regulations regarding the disposal of your packaging materials, dead battery and used phone. Do not dispose of dead battery or used phone in municipal waste or by incineration. Otherwise, explosion may occur. Please recycle.
- This HUAWEI device complies with Directive 2002/95/EC on the restriction of the use of certain hazardous substances in electrical and electronic equipment.

■ Emergency Call

Your phone can be used to place emergency calls. However, connections in all conditions cannot be guaranteed. Never rely solely on the phone for essential communications.

■ Battery

- Use batteries approved by the manufacturer only. Otherwise, malfunction, fire, or explosion may occur.
- Do not dispose of the battery by incineration. Otherwise, the battery might ignite or explode.
- Do not connect the two poles of the battery with conductors such as cables, jewelry, or any other metal. Otherwise, the battery may short-circuit, causing injury.
- Keep mobile phone at a temperature between 0 °C and 45 °C while the battery is being charged. Store the battery at a temperature between -20 °C and 60 °C. Storage at temperatures that are too low (especially below 0 °C) or too high, will reduce the capacity and life of the battery. More importantly, improper storage may destabilize the battery, rendering it unsafe.

- Do not disassemble the battery or solder the battery poles. Otherwise fluid leakage, overheating, fire, or explosion may occur.
- If battery leakage, smoke, or strange smells occur, remove battery from phone and keep it away from open flame to avoid fire or explosion. Then take to local authorized service center for repair.
- If battery fluid contacts your skin or clothing, wash with clean water immediately to avoid skin irritation.
- If battery fluid gets into eyes, do not rub them. This could cause injury. Wash with clean water and consult a doctor immediately.
- If battery deformation, color change or abnormal heating occurs during storage or charging, remove battery immediately and properly dispose. Otherwise, battery leakage, overheating, explosion, or fire may occur.
- Do not force battery into place during installation.
- Do not remove the battery while the phone is turned on.

■ **Charger**

- Use only manufacturer-approved chargers. Use of a non-approved charger may cause malfunction, and will also void warranty.
- Do not short-circuit the charger. Short-circuiting the charger may cause fire or malfunction of the charger.
- If the power cord is damaged (for example, if the wire is exposed or broken), or the plug becomes loose, stop using the cable at once. Otherwise, electric shock, short-circuit, or fire may occur.
- Do not use the charger in a dusty or damp environment. Keep the power cord away from excessive heat or flame.
- Use only the AC-power supply defined in the specifications of the charger. Improper power voltage or current can cause fire or malfunction of the charger.

- During charging, do not touch the plug, power cord or the charger itself with wet skin. Otherwise, electric shock could occur.
- If liquid leaks into the charger, remove the plug of the charger from the socket immediately. Otherwise, overheating, fire or other malfunction may occur.
- The Travel Adaptor for this phone meets UL 1310 safety requirements. Please adhere to the safety instructions per UL guidelines.

■ Certification Information (SAR)

THIS DEVICE MEETS THE CANADIAN AND UNITED STATES GOVERNMENTS' REQUIREMENTS FOR EXPOSURE TO RADIO FREQUENCY ELECTROMAGNETIC FIELD.

Your mobile phone is a low-power radio transmitter and receiver. When it is turned on, it emits low levels of radio frequency energy ("RF") (also known as radio waves or radio frequency fields).

Governments around the world have adopted comprehensive international safety guidelines, developed by scientific organizations, like ICNIRP (International Commission on Non-Ionizing Radiation Protection) and IEEE (Institute of Electrical and Electronics Engineers Inc.), through periodic and thorough evaluation of scientific studies. These guidelines establish permitted levels of radio wave exposure for the general population. The levels include a safety margin designed to assure the safety of all persons, regardless of age and health, and to account for any variations in measurements.

Specific Absorption Rate (SAR) is the unit of measurement for the amount of radio frequency energy absorbed by the body when using a mobile phone. The SAR value is determined at the highest certified power level in laboratory conditions, but the actual SAR level of the mobile phone while operating can be well below the

value. This is because the mobile phone is designed to use the minimum power required to reach the network.

All models of Huawei's mobile phones are designed to meet radio frequency exposure guidelines. Before a phone model is available for sale to the public, it must be tested and certified by the FCC that it does not exceed the limit established by the government-adopted requirement for RF exposure. The tests are performed in positions and locations (that is, at the ear and worn on the body) as required by the FCC for each model. For body worn operation, this phone has been tested and meets FCC RF exposure guidelines when the handset is positioned a minimum of 15 mm from the body with an accessory that contains no metal part. Use of other accessories may not ensure compliance with FCC RF exposure guidelines.

The SAR limit adopted for this particular device by the USA and Canada is 1.6 watts/kilogram (W/kg) averaged over one gram of tissue. The highest SAR value reported to the FCC and IC for this device type when tested for use at the ear is 1.14 W/kg, and when properly worn on the body is 0.943 W/kg.

■ **Hearing Aid Compatibility (HAC) regulations for Mobile phones**

In 2003, the FCC adopted rules to make digital wireless telephones compatible with hearing aids and cochlear implants. Although analog wireless phones do not usually cause interference with hearing aids or cochlear implants, digital wireless phones sometimes do because of electromagnetic energy emitted by the phone's antenna, backlight, or other components.

Your phone is compliant with FCC HAC regulations (ANSI C63.19).

While some wireless phones are used near some hearing devices (hearing aids and cochlear implants), users may detect a buzzing, humming, or whining noise.

Some hearing devices are more immune than others to this interference noise, and phones also vary in the amount of interference they generate.

The wireless telephone industry has developed a rating system for wireless phones, to assist hearing device users find phones that may be compatible with their hearing devices. Not all phones have been rated. Phones that are rated have the rating on their box or a label located on the box. The ratings are not guarantees. Results will vary depending on the user's hearing device and hearing loss. If your hearing device happens to be vulnerable to interference, you may not be able to use a rated phone successfully. Trying out the phone with your hearing device is the best way to evaluate it for your personal needs.

M-Ratings: Phones rated M3 or M4 meet FCC requirements and are likely to generate less interference to hearing devices than phones that are not labeled.

M4 is the better/higher of the two ratings. Your phone meets the M4 level rating. Hearing devices may also be rated. Your hearing device manufacturer or hearing health professional may help you find this rating.

For more information about the FCC Hearing Aid Compatibility please go to

<http://www.fcc.gov/cgb/dro>

■ FCC Statement

This device complies with Part 15 of the FCC Rules. Operation is subject to the following two conditions: (1) this device may not cause harmful interference, and (2) this device must accept any

interference received, including interference that may cause undesired operation.

Warning: Changes or modifications made to this equipment not expressly approved by *HUAWEI* may void the FCC authorization for the user to operate this equipment.

■ **Proposition 65 Compliance Statement**

WARNING: This product contains chemicals known to the State of California to cause cancer and birth defects or other reproductive harm. Wash hands after handling.

17 Huawei Technologies Co., Ltd. Limited Warranty

Huawei Technologies Co., Ltd. ("Huawei") represents and warrants to the original purchaser ("Purchaser") that Huawei's phones and accessories ("Product") are free from material defects, including improper or inferior workmanship, materials, and design, during the designated warranty period, and subject to the following terms and conditions, when used normally and in accordance with all operating instructions:

1. Warranty Period: Coverage under this warranty is limited to the following time periods:
 - a) Phone: a period of 12 months from the date of purchase.
 - b) Battery and Charger: a period of 12 months from the date of purchase.
 - c) Other accessories (If included in the box set): a period of 3 months from the date of purchase.
2. This limited warranty only applies to products manufactured by or for Huawei and that can be identified by the "Huawei" trademark, trade name, or logo affixed to them. The limited warranty does not apply to any non-Huawei products or software.
3. The Warranty extends only to Purchasers who purchased the Product in the United States of America and is not assignable or transferable to any subsequent purchaser/customer.
4. During the limited warranty period, Huawei will repair or replace at Huawei's sole option, any parts of the Product that are defective or malfunction during normal usage. Huawei reserves the right to use new or refurbished replacement parts in repair of the Product.

5. This limited warranty covers only the costs of parts and labor. Other related costs such as shipping and delivery costs may be born by purchaser at Huawei's option.
6. At Huawei's request, Purchaser must prove the date of the original purchase of the Product by a dated bill of sale or dated itemized receipt.
7. This warranty does not cover damage resulting from:
 - a) Abuse, accident, misuse, improper storage, exposure to liquid, moisture, or dampness;
 - b) External causes such as from collision, fire, flooding, sand, dirt, windstorm, lightning, or earthquake;
 - c) Exposure to extreme weather conditions, Acts of God, theft, blown fuse, or improper use of any electrical source;
 - d) Computer or internet viruses, bugs, worms, Trojan Horses, cancelbots;
 - e) Use with non-Huawei products or products not recommended for use with Huawei products;
 - f) normal wear and tear of the equipment;
 - g) Usage of equipment other than its normal and customary manner;
 - h) Improper testing, operation, maintenance, installation, or any alteration or modification of Product;
 - i) Consumable parts, such as batteries, unless damage has occurred due to a defect in Huawei materials and workmanship;
 - j) Service performed by anyone who is not a Huawei representative or an authorized Huawei service provider;
 - k) Other acts which are not the fault of Huawei, including damage caused by shipping;
 - l) Cosmetic damages, including but not limited to dents or scratches in decorative, structural, or non-operative parts resulting from normal customer use;
 - m) Spillage of food or liquid, corrosion, rust or incorrect voltage; and

- n) The defective function of the cellular system or inadequate signal reception by the external antenna, or viruses or other software problems introduced into the Product.
8. Huawei does not warrant that the operation of this product will be uninterrupted or error-free.
9. This warranty will also be null and void in any of the following events:
- a) The serial number or warranty seal on the equipment has been altered, defaced or removed;
 - b) Any term contained in this warranty has been altered or modified in any way without prior written consent of Huawei;
 - c) Huawei has not been notified by Purchaser of the alleged defect or malfunction of the Product during the applicable warranty period.
10. If Product is returned to Huawei after the expiration of the warranty period, Huawei's normal service policies shall apply and Purchaser will be charged accordingly.
- a) Huawei assumes no obligation or liability beyond that which is expressly provided for in this limited warranty.
 - b) All warranty information, pricing, product features and specifications are subject to change.
11. This limited warranty provides Purchaser's sole and exclusive remedy to be provided by Huawei. The agents, employees, distributors, and dealers of Huawei products are not authorized to make modifications to this limited warranty, or make additional warranties binding on Huawei.

LIMIT OF LIABILITY

12. HUAWEI'S LIMIT OF LIABILITY UNDER THIS LIMITED WARRANTY SHALL BE THE ACTUAL CASH VALUE OF THE PRODUCT AT THE TIME PURCHASER RETURNS THE PRODUCT FOR REPAIR, AS

DETERMINED BY THE PRICE PAID BY THE PURCHASER FOR THE PRODUCT LESS A REASONABLE AMOUNT OF USAGE. HUAWEI SHALL NOT BE LIABLE FOR ANY OTHER LOSSES OR DAMAGES SUCH AS SPECIAL, INCIDENTAL, CONSEQUENTIAL, OR PUNITIVE DAMAGES (INCLUDING BUT NOT LIMITED TO LOSS OF ANTICIPATED BENEFITS OR PROFITS, LOSS OF SAVINGS OR REVENUE, LOSS OF DATA, LOSS OF USE OF THE PRODUCT OR ANY ASSOCIATED EQUIPMENT, COST OF CAPITAL, COST OF ANY SUBSTITUTE EQUIPMENT OR FACILITIES, DOWNTIME, ANY COSTS OF RECOVERING, REPROGRAMMING, OR REPRODUCING ANY PROGRAM OR DATA, ANY FAILURE TO MAINTAIN THE CONFIDENTIALITY OF DATA STORED ON THE PRODUCT, THE CLAIMS OF ANY THIRD PARTIES, INCLUDING SUBSEQUENT PURCHASERS, AND INJURY TO PROPERTY, RESULTING FROM THE PURCHASE OR USE OF THE PRODUCT OR ARISING FROM BREACH OF THIS WARRANTY, BREACH OF CONTRACT, NEGLIGENCE, STRICT LIABILITY, OR ANY OTHER LEGAL OR EQUITABLE THEORY, EVEN IF HUAWEI KNEW OF THE LIKELIHOOD OF SUCH DAMAGES). HUAWEI SHALL NOT BE LIABLE FOR DELAY IN RENDERING SERVICE UNDER THE LIMITED WARRANTY, OR LOSS OF USE DURING THE PERIOD THAT THE PRODUCT IS BEING REPAIRED.

DISCLAIMER OF WARRANTY

13. HUAWEI'S LIABILITY UNDER EITHER THE IMPLIED WARRANTY OF MERCHANTABILITY OR FITNESS FOR A PARTICULAR PURPOSE, SHALL BE LIMITED TO THE DURATION OF THE FOREGOING LIMITED WRITTEN WARRANTY. OTHERWISE, THE FOREGOING LIMITED WARRANTY IS PURCHASER'S SOLE AND EXCLUSIVE

REMEDY AND IS IN LIEU OF ALL OTHER WARRANTIES, EXPRESS OR IMPLIED.

14. Some states do not allow exclusion or limitation of incidental, consequential, or punitive damages, or permit limitations on the length of implied warranties, so certain of these warranty limitations may not apply to Purchaser. This limited warranty gives Purchaser specific legal rights; Purchaser may also have other rights which vary from state to state. If any term of this limited warranty is held to be illegal or unenforceable, the legality or enforceability of the remaining terms shall not be affected or impaired.
15. This limited warranty allocates risk of Product failure between Purchaser and Huawei, and Huawei's Product pricing reflects this allocation of risk and the limitations of liability contained in this limited warranty.

■ Contact Huawei

TEL: 1877 - 4 - HUAWEI

WEB SITE: [HTTP://MOBILE.HUAWEI.COM](http://mobile.huawei.com)

* This contact information may change without notice. Please contact your authorized Huawei retailer for updated contact information.