



RRU3203 V100R001C01  
**Installation Guide**









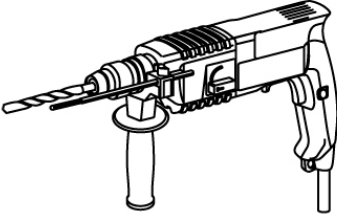
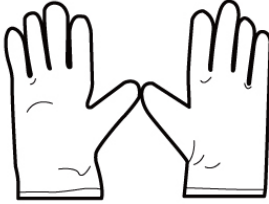

Issue: 01  
Date: 2010-04-13

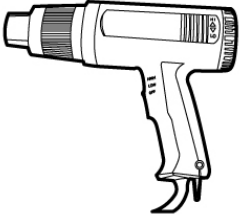
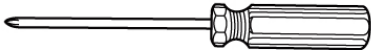
HUAWEI TECHNOLOGIES CO., LTD.

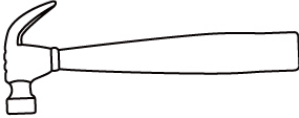
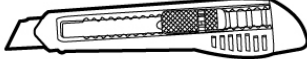
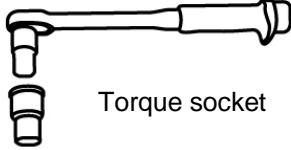
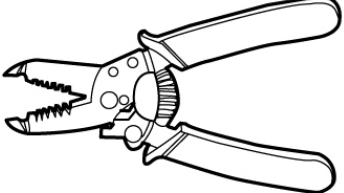
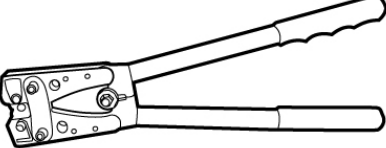
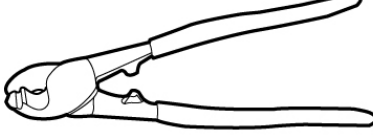

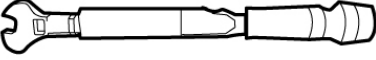
<b>Installation Tools .....</b>	<b>2</b>
<b>Space Requirements .....</b>	<b>3</b>
<b>Installation Modes .....</b>	<b>4</b>
<b>Installation Procedure .....</b>	<b>6</b>
<b>Components Delivered with the RRU .....</b>	<b>6</b>
<b>Installing the RRU on a Metal Pole .....</b>	<b>7</b>
<b>Installing the RRU on a U-Steel .....</b>	<b>11</b>
<b>Installing the RRU on an Angle Steel .....</b>	<b>11</b>
<b>Installing the RRU on Wall .....</b>	<b>12</b>
<b>Installing the RRU Cables .....</b>	<b>14</b>
<b>RRU Hardware Installation Checklist .....</b>	<b>20</b>
<b>Powering On the RRU .....</b>	<b>20</b>
<b>Appendix.....</b>	<b>21</b>
<b>Change History .....</b>	<b>26</b>

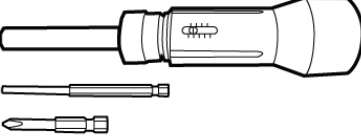
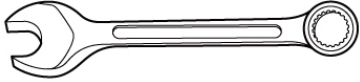
# Installation Tools

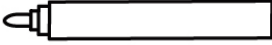
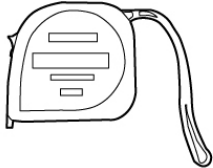
 <p>Hammer drill (with bit 14)</p>	 <p>ESD gloves</p>	 <p>Vacuum cleaner</p>
 <p>Heat gun</p>	 <p>Phillips screwdriver (M3~M6)</p>	 <p>Flat-head screwdriver (M3~M6)</p>
 <p>Claw hammer</p>	 <p>Knife</p>  <p>Torque socket</p>	 <p>Wire stripper</p>
 <p>Power cable crimping pliers</p>	 <p>Wire cutter</p>	 <p>Adjustable wrench (with the diameter of at least 32 mm [1.3 in.])</p>
 <p>Torque wrench</p>  <p>Level</p>	 <p>Torque screwdriver</p>	 <p>Combination wrench (21mm~21mm) for pole installation (17mm~17mm) for wall installation</p>
 <p>Multimeter</p>	 <p>Marking pen (with the diameter of no more than 10 mm [0.4 in.])</p>	 <p>Measuring tape</p>

# Installation Options

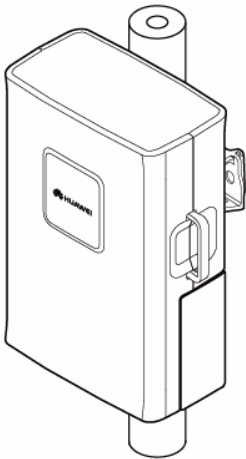

On a metal pole

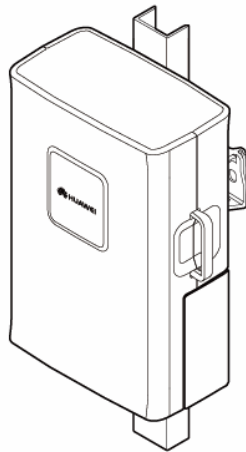

On a U-steel

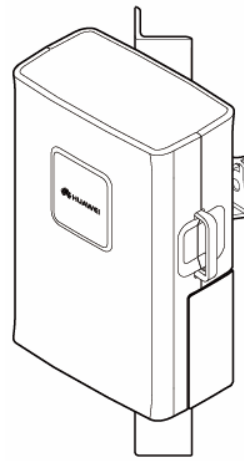

On an angle steel

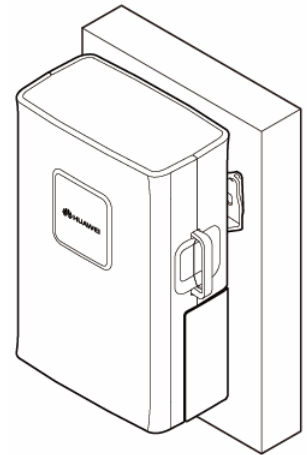

On a wall

The following figure describes the specifications for the metal pole, angle steel, and U-steel where the RRU is installed.

60 mm [2.4 in.] to 114 mm [4.5 in.]

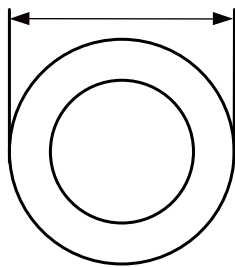

Metal pole

63 mm [2.5 in.] to 75 mm [3 in.]

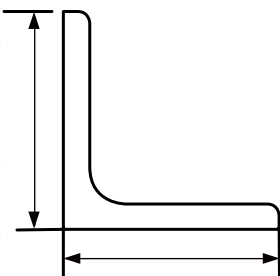

Angle steel

50 mm [2 in.] to 100 mm [3.9 in.]

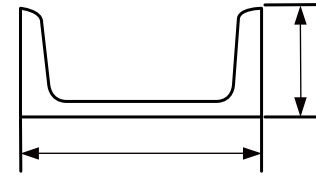

U-steel

30 mm [1.2 in.] to 50 mm [2.0 in.]

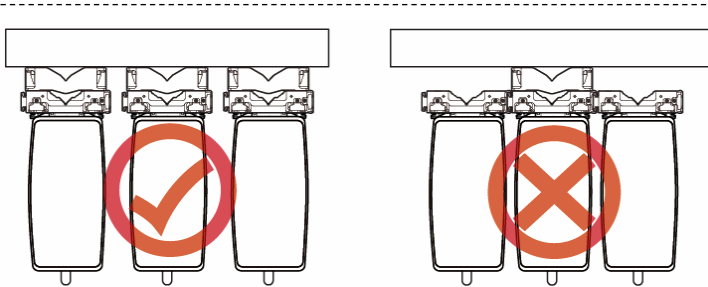

## WARNING

The brackets cannot be combined when the RRUs are installed on the wall.

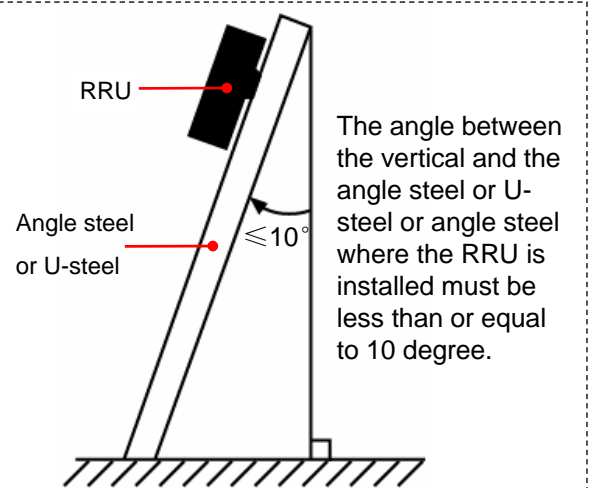

The angle between the vertical and the angle steel or U-steel or angle steel where the RRU is installed must be less than or equal to 10 degree.



## WARNING

- A maximum of two RRUs can be installed on a metal pole with a diameter of 60 mm [2.4 in.] to 75 mm [3 in.] , and the installation mode must be standard mode. Three or more RRUs must be installed on a metal pole with a diameter of 76 mm [3 in.] to 114 mm [4.5 in.] in a centralized way.
- It is recommended that only one RRU be installed on a U-steel or an angle steel.
- When installed on a tower, one RRU can be installed only in standard mode or reverse mode rather than side-mounted. Two RRUs cannot be installed in back-to-back mode.

# Dimensions and Installation Clearance

## a Dimensions of the RRU

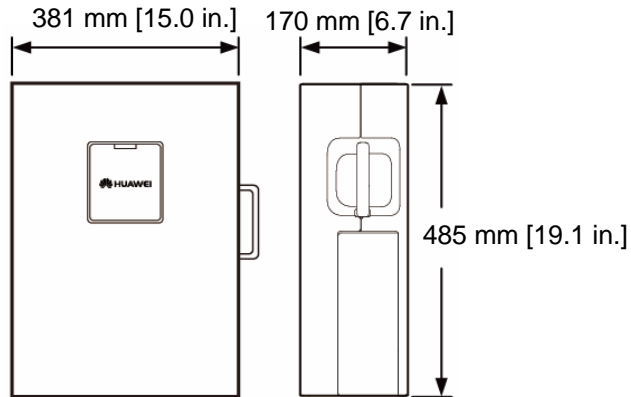

## b Recommended Clearance for a Single RRU

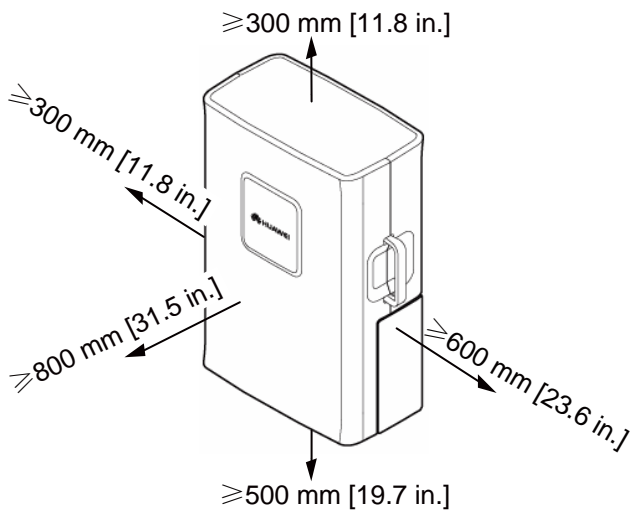

## c Minimum Clearance for a Single RRU

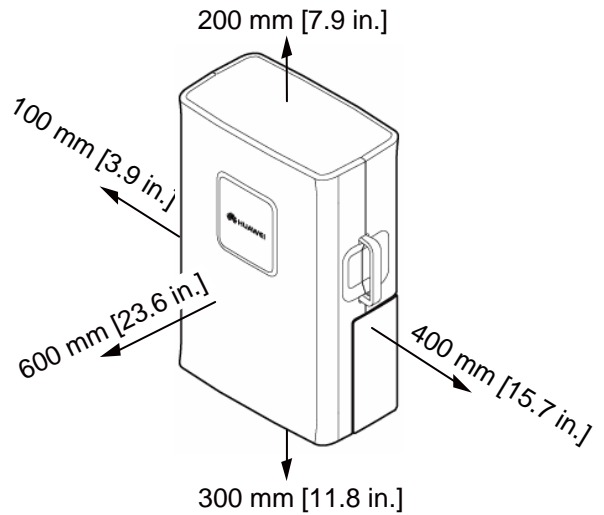

## d Recommended Clearance for Multiple Centralized RRUs

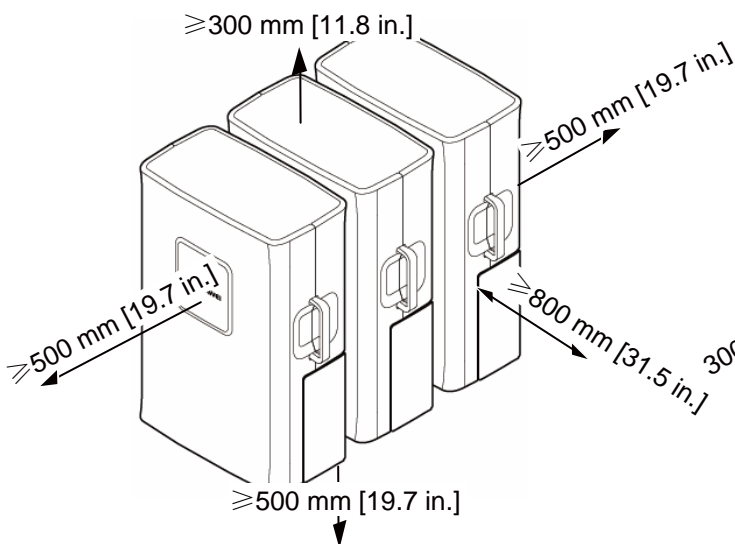

## e Minimum Clearance for Multiple Centralized RRUs

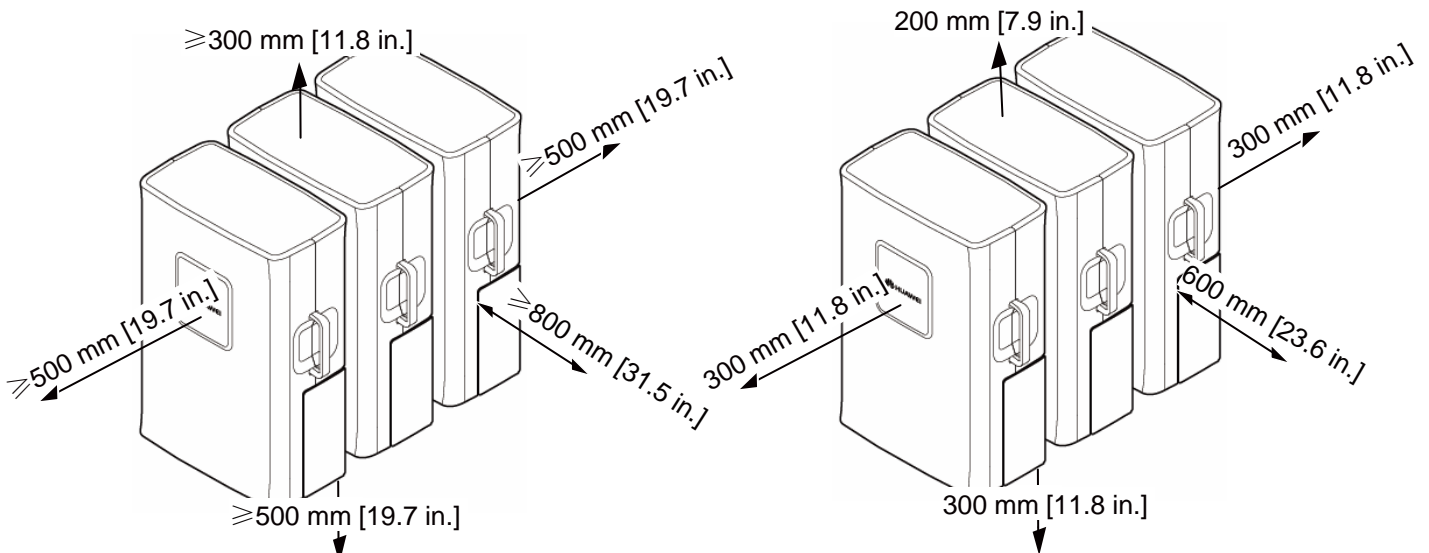

# Dimensions and Installation Clearance

**f** Recommended Horizontal Spacing for Two RRUs Installed in Parallel

**g** Minimum Horizontal Spacing for Two RRUs Installed in Parallel

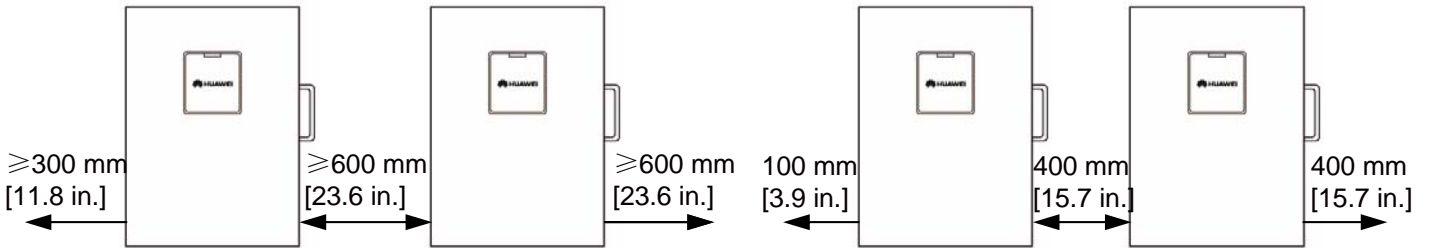

**h** Recommended Vertical Spacing for Two RRUs Installed in Parallel

**i** Minimum Vertical Spacing for Two RRUs Installed in Parallel

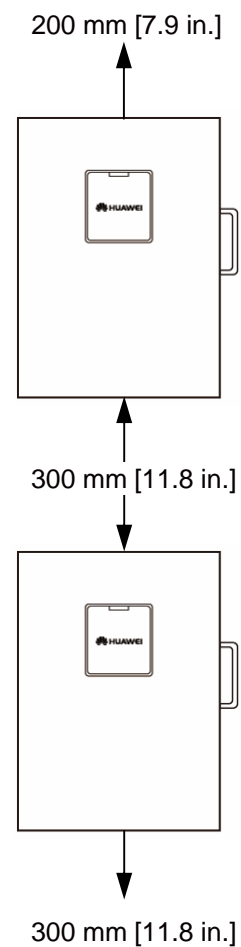
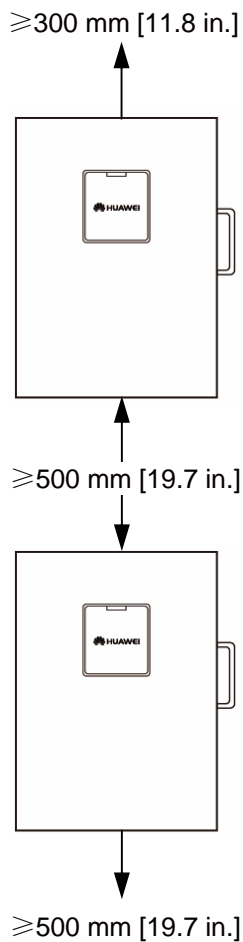

# Installation Procedure

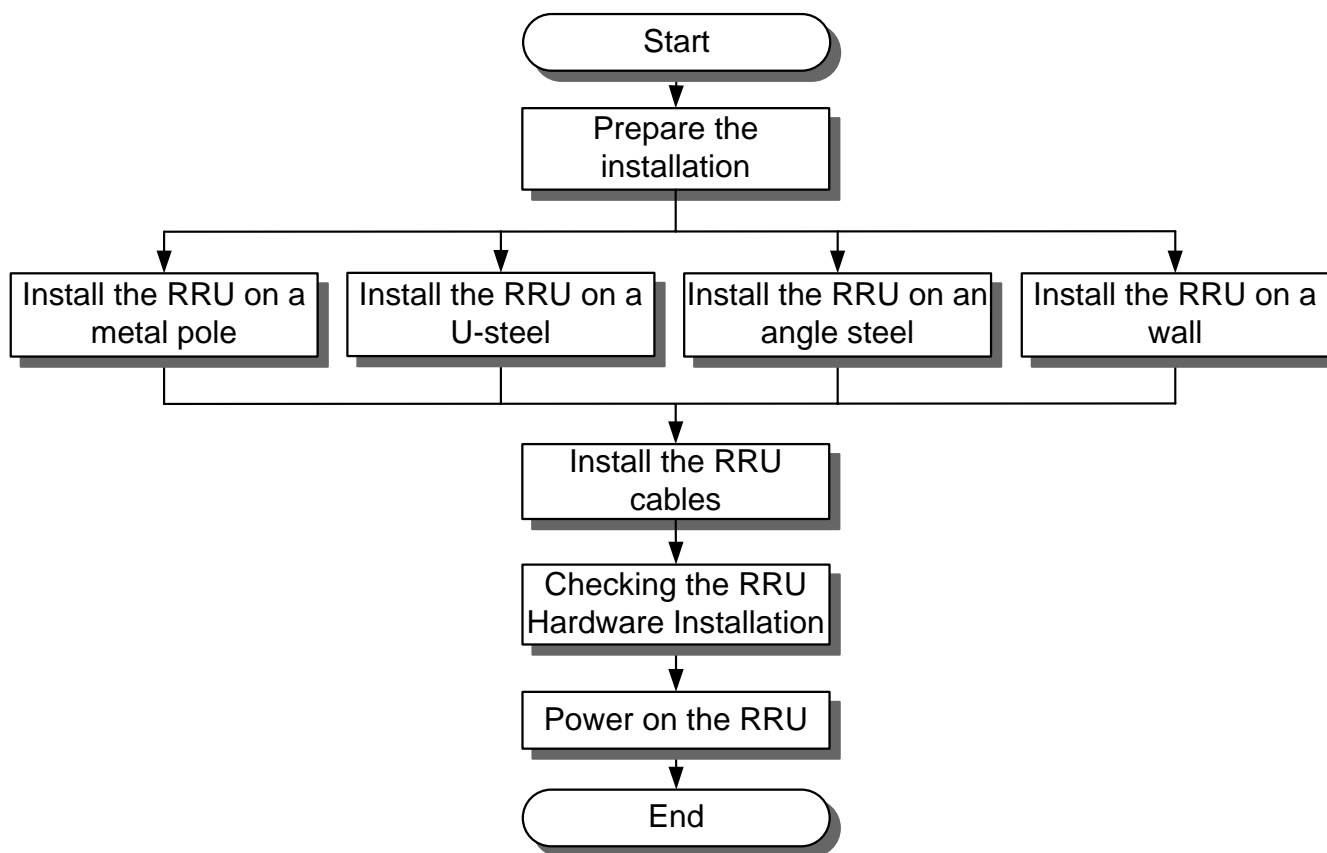

## Preparing the Installation

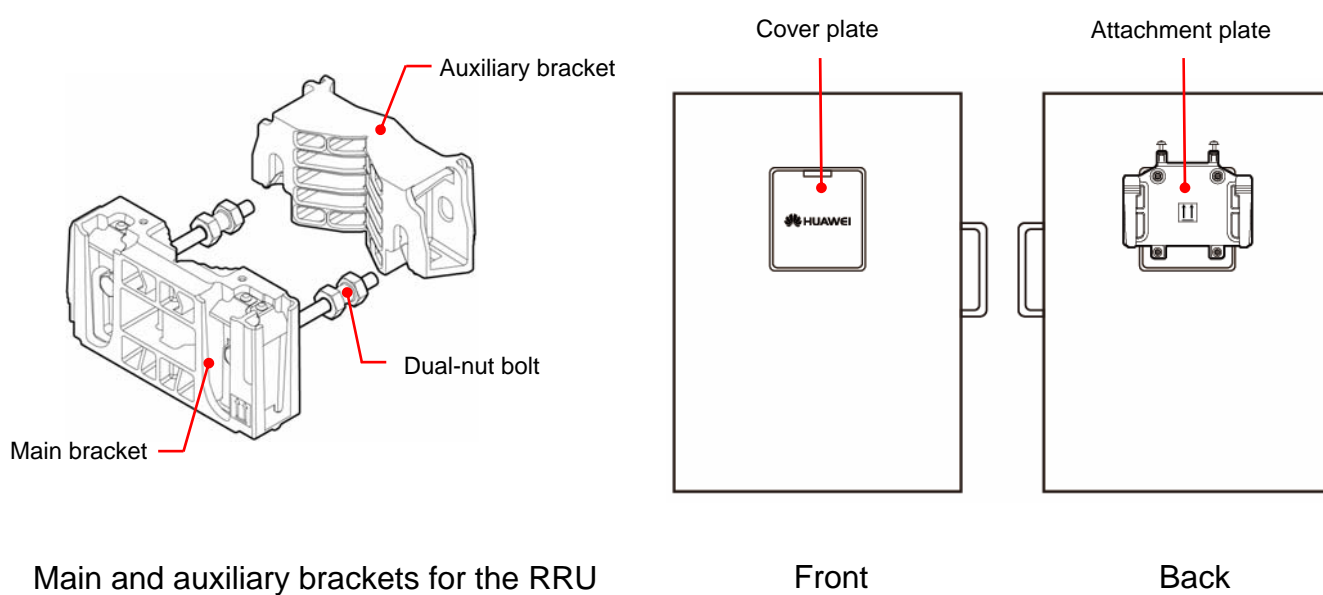

# Installing the RRU on a Metal Pole

## a Installing a Single RRU on a Metal Pole

### 1. Install the main bracket.

**CAUTION**  
When installing the main bracket, ensure that the contact piece on the bracket is fixed.

1200 mm [47.2 in.]~  
1600 mm [63 in.]

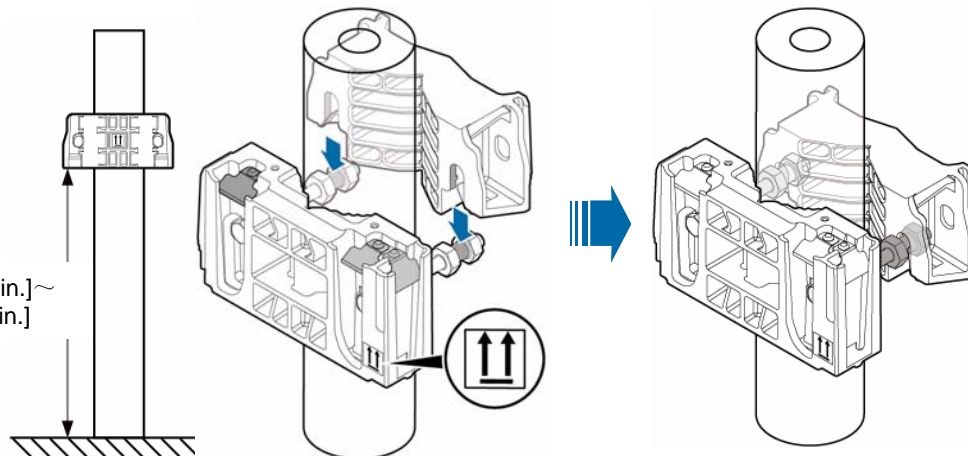

#### **TIP**

You may fit one end of the auxiliary bracket on one dual-nut bolt assembly and then the other end on the other dual-nut bolt assembly during the installation.

### 2. Use an adjustable wrench to tighten the nut until the fastening torque is 40 N·m [354 lbf·in.]. In this way, the main and auxiliary brackets are secured on the pole.

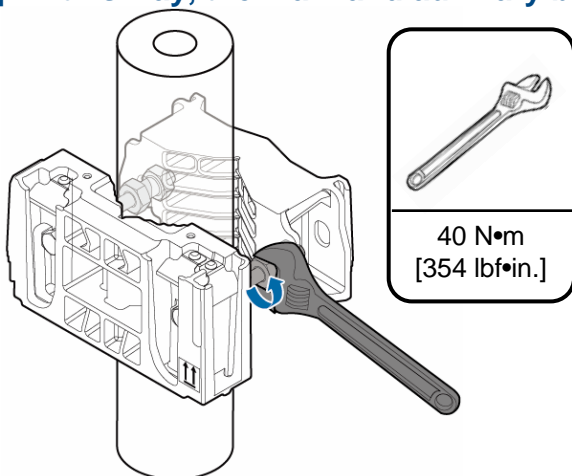

#### **CAUTION**

Fasten the two dual-nut bolt assemblies alternatively. After the brackets are secure, use a tape to measure the spacing between the main bracket and the auxiliary bracket at the two sides and ensure that the spacing is the same.

### 3. Install the RRU on the main bracket. When you hear click sound, you can infer that the RRU is in position.

#### **CAUTION**

- The weight-bearing capacity of the RF ports at the bottom of the RRU is low. Do not place the RRU at its bottom.
- During the operation, place the foam pad or cardboard under the RRU to prevent any damage to the housing of the RRU.

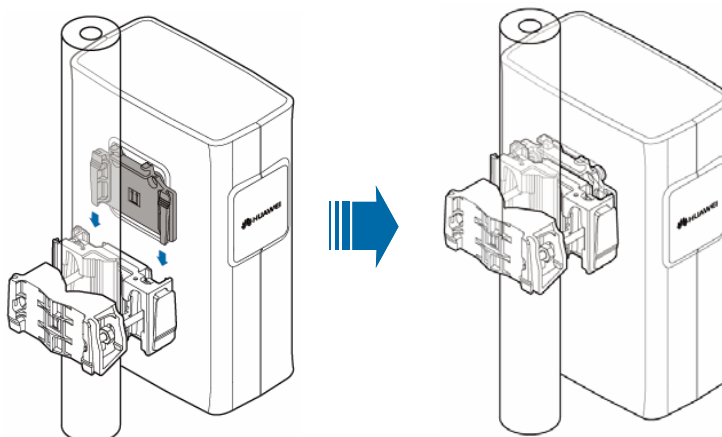



# Installing the RRU on a Metal Pole

## b Installing Two RRUs Back-To-Back on a Metal Pole

1. Install an RRU. For details, see page 7 [Installing a Single RRU on a Metal Pole](#).

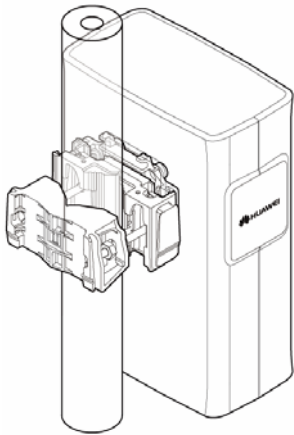

2. Install the main fixture for another RRU.

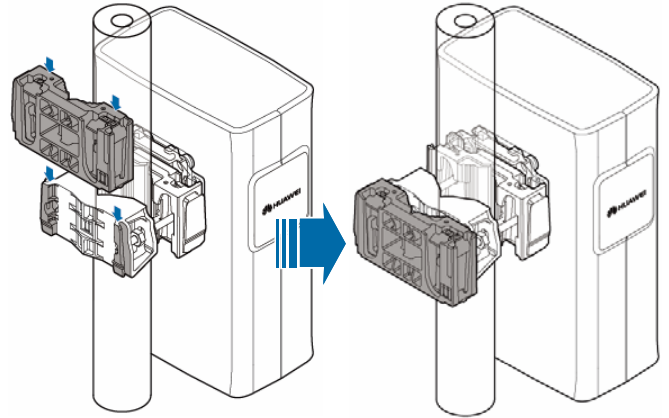

3. Reinstall the attachment plate and cover plate on the second RRU by interchanging their positions.

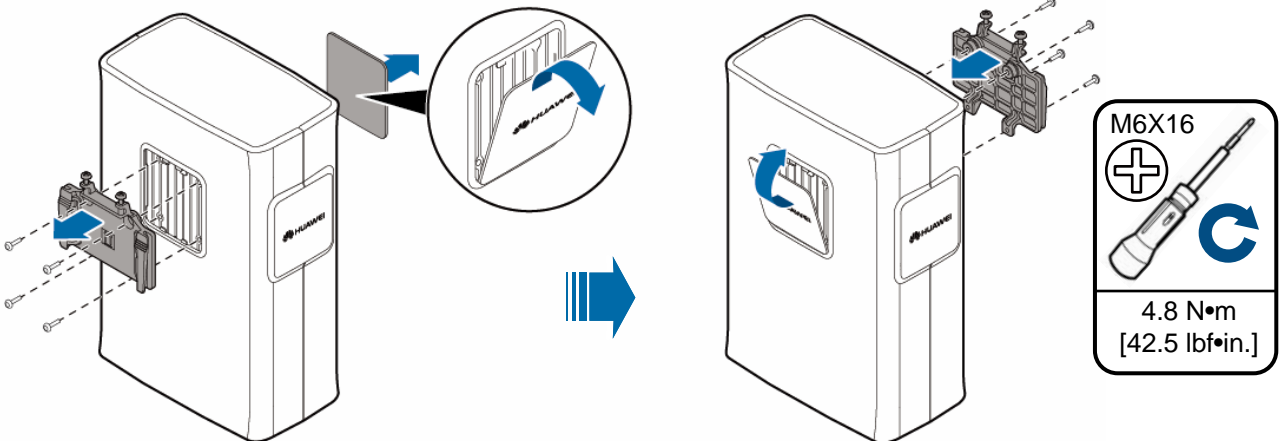

4. Install the second RRU on the main bracket.

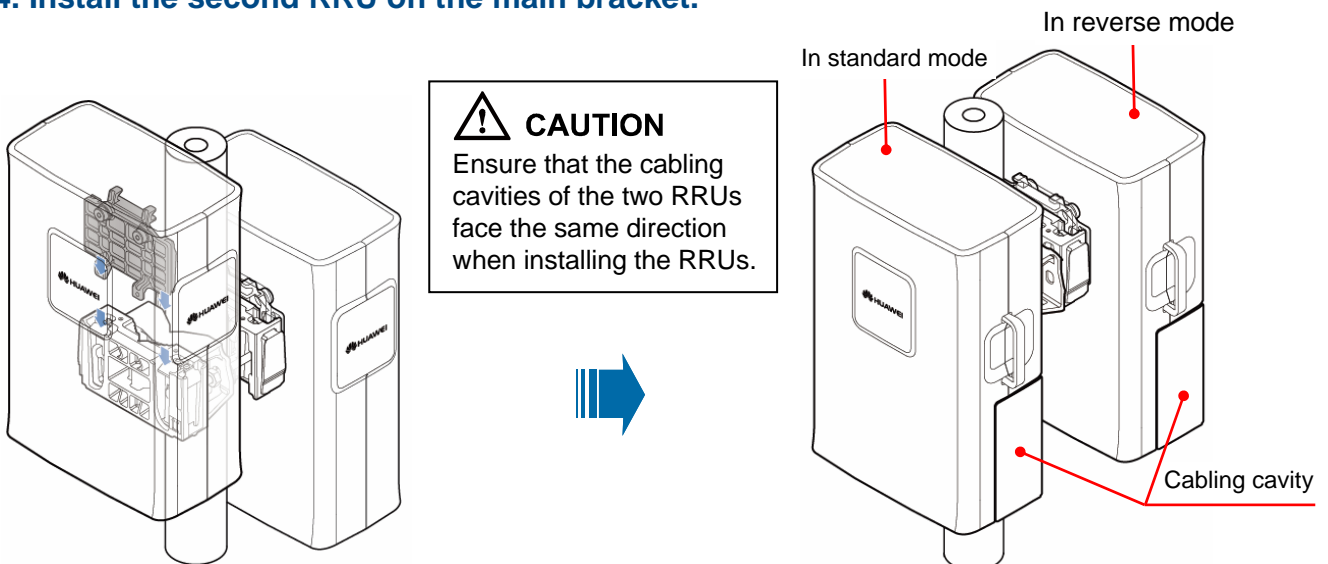

# Installing the RRU on a Metal Pole

## C Installing Multiple RRUs in Centralized Mode

1. Install the main fixture and the auxiliary fixture. For details, see page 7 [Installing a Single RRU in Ordinary Mode](#).

2. Relocate the attachment plate.

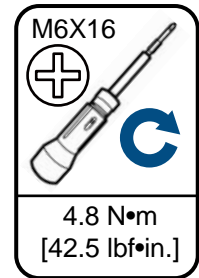
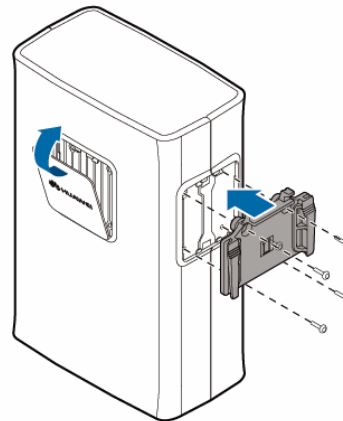
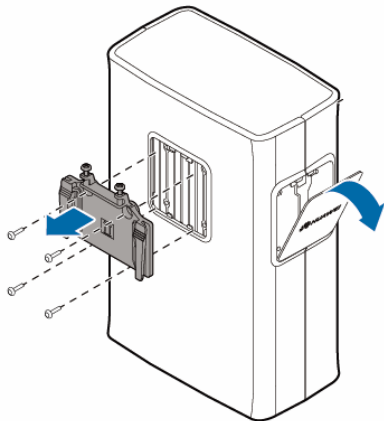

3. Fit the tabs on the attachment plate of the RRU into the anchor slots on the main fixture.

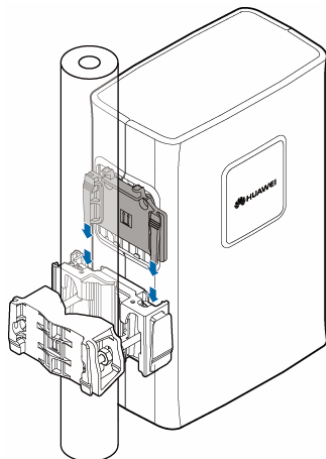

4. Install the second main fixture.

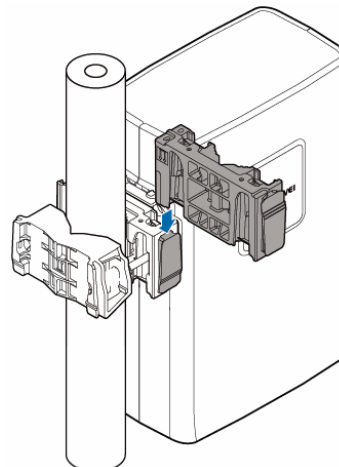

5. Fit the tabs on the attachment plate of the second RRU into the anchor slots on the second main fixture.

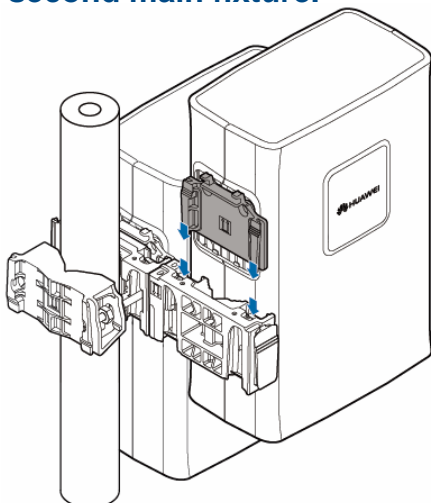

6. Install the third RRU.

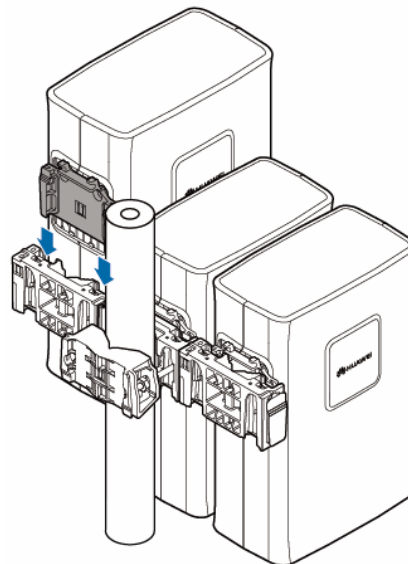

# Installing the RRU on a Metal Pole

## C Installing Multiple RRUs in Centralized Mode

7. Install the fourth main fixture.

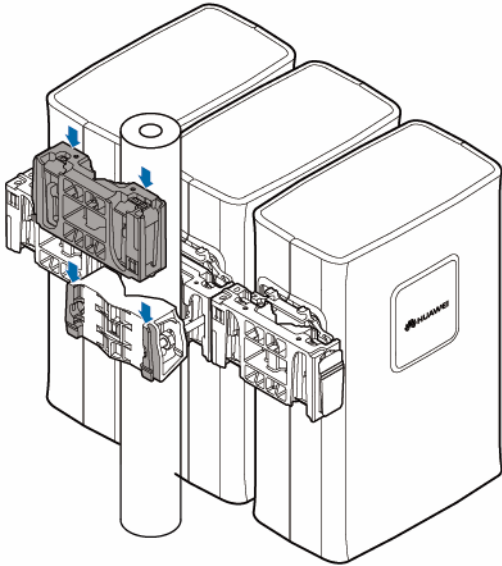

8. Fit the tabs on the attachment plate of the fourth RRU into the anchor slots on the fourth main fixture.

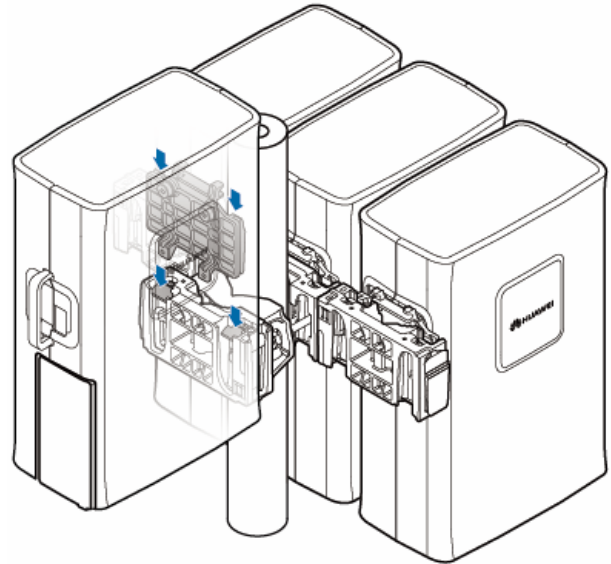

9. Four RRUs installed in centralized mode.

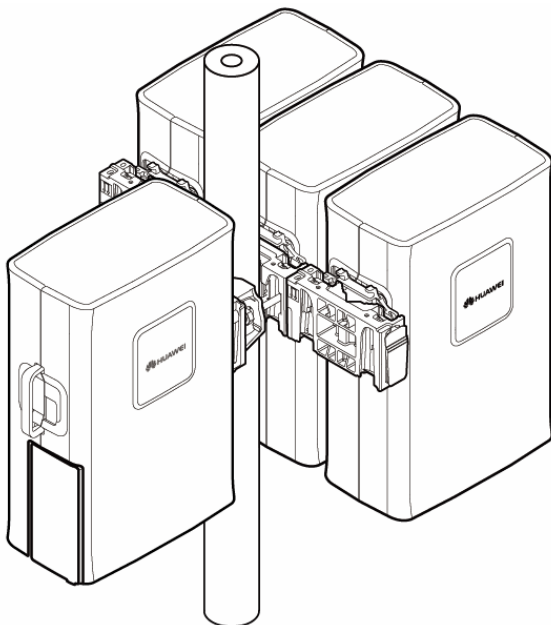

10. Six RRUs installed in centralized mode.

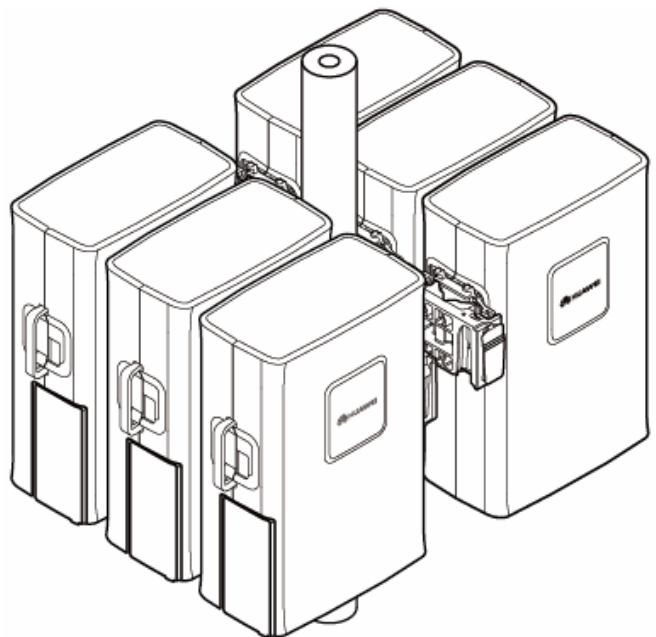

## Installing the RRU on a U-Steel

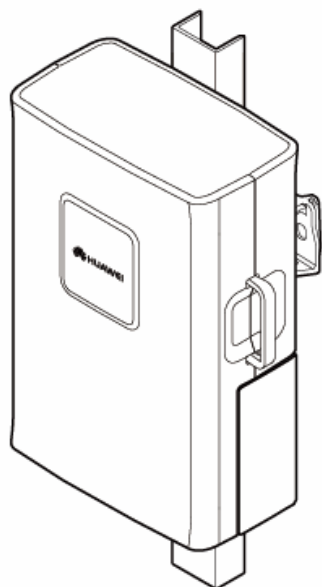

Plan view

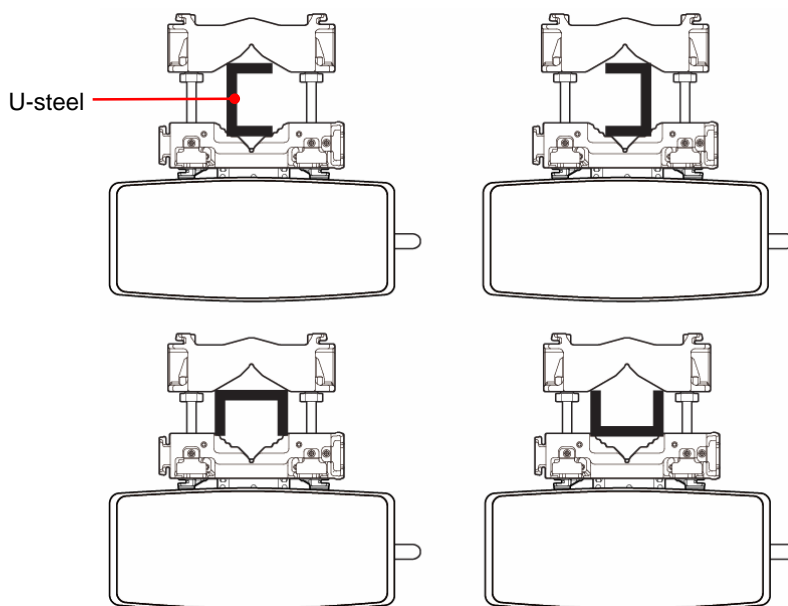

### NOTE

- The procedure for installing the RRU on a U-steel is the same as that for installing the RRU on a metal pole.
- It is recommended that only one RRU be installed on a U-steel.

## Installing the RRU on an Angle Steel

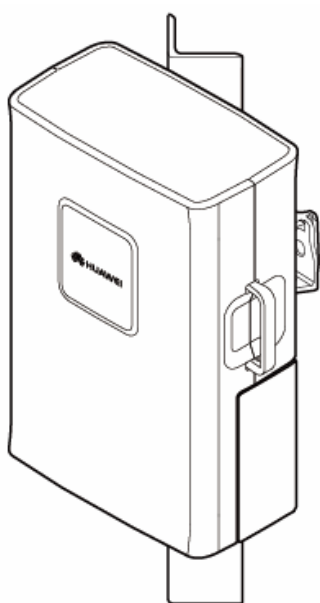

Plan view

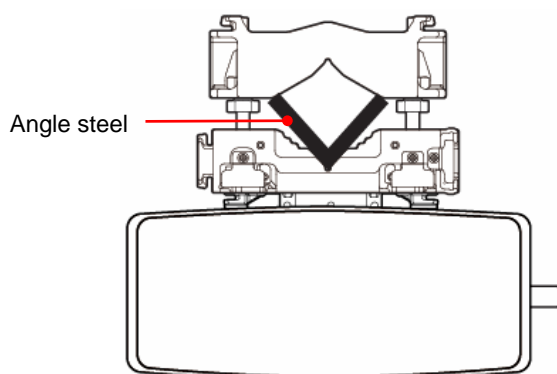

### NOTE

- The procedure for installing the RRU on an angle steel is the same as that for installing the RRU on a metal pole.
- It is recommended that only one RRU be installed on an angle steel.

# Installing the RRU on a Wall

1. Place the auxiliary bracket at the installation position. Use a level to check that the auxiliary bracket is placed horizontally. Then, mark the anchor points by using a marking pen.

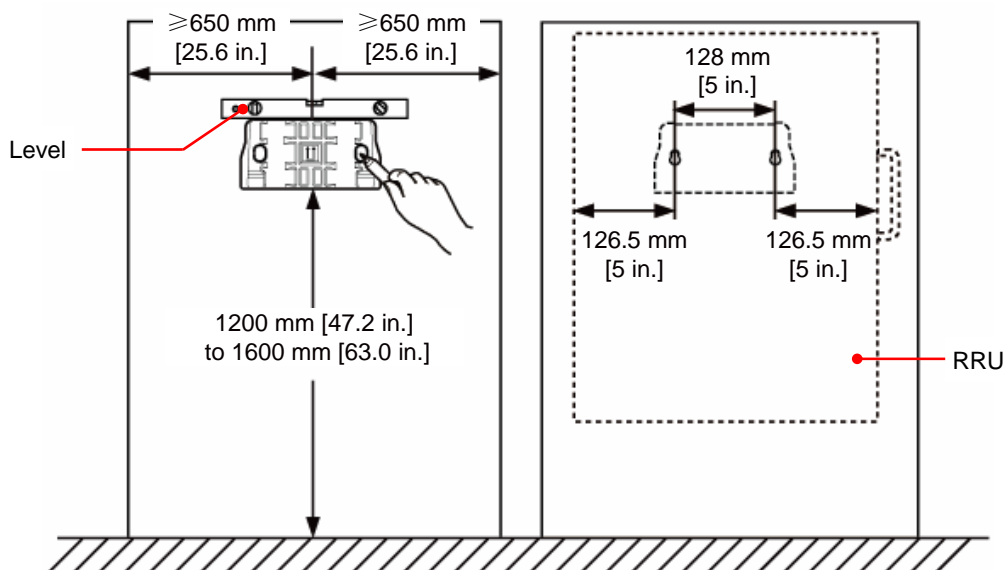

## NOTE

- It is recommended that the auxiliary bracket be 1,200 mm [47.2 in.] to 1,600 mm [63.0 in.] above the ground.
- The RRUs cannot be installed on a wall in centralized mode. Therefore, expansion bolt assemblies should be prepared for each RRU.

2. Drill holes at the anchor points and then install the expansion bolt assemblies.

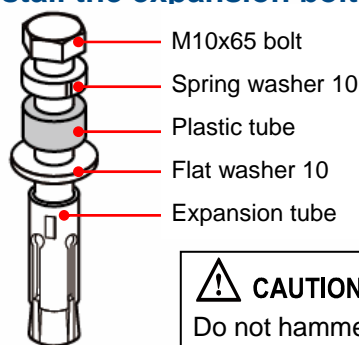
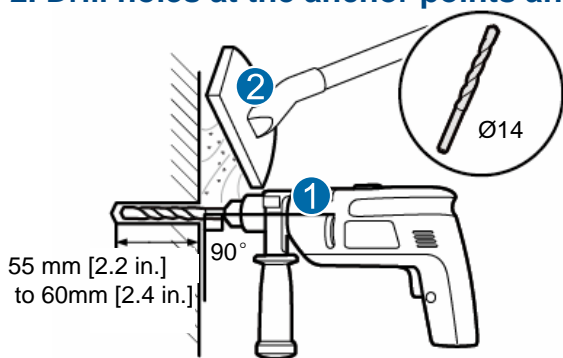

## CAUTION

Do not hammer the bolt entirely into the wall. Instead, leave 20 mm to 30 mm of the bolt outside the wall.

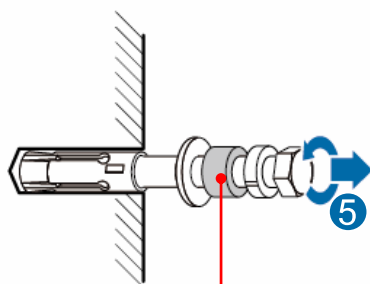
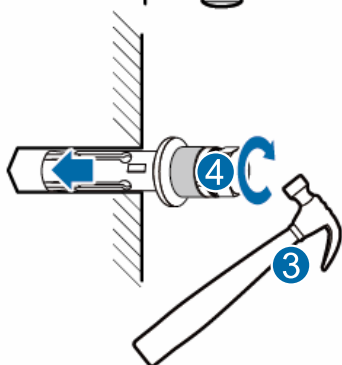

After the expansion bolt is removed, dispose of the plastic tube.

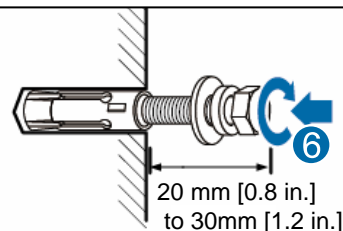

## NOTE

When the RRU is installed on a wall, the requirements are as follows:

- For one RRU, the wall has a weight-bearing capacity of 96 kg [211.7 lb].
- The fastening torque of the expansion bolt reaches 30 N•m [265.5 lbf•in.] the expansion bolt works properly, and no damages such as cracks are on the wall.

# Installing the RRU on a Wall

3. Fit the auxiliary bracket on the expansion bolts downward, and then tighten the bolts by using a combination wrench 17 mm [0.7 in.].

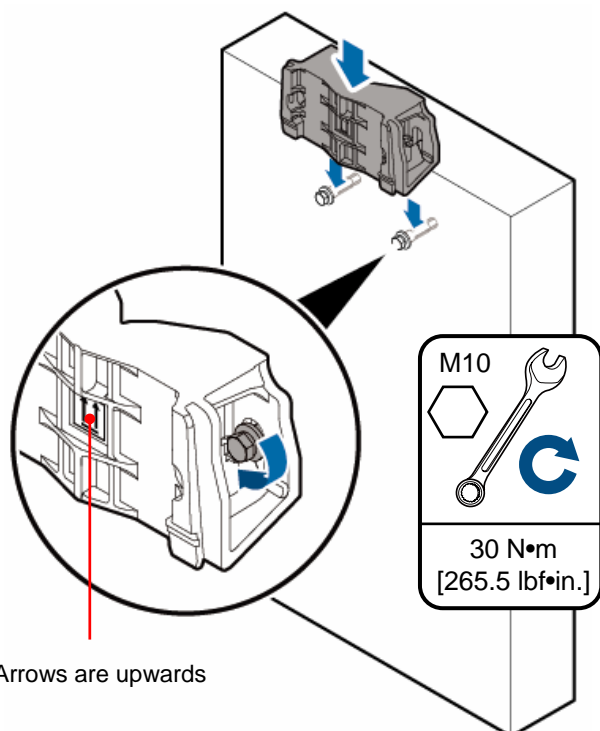

4. Install the main bracket.

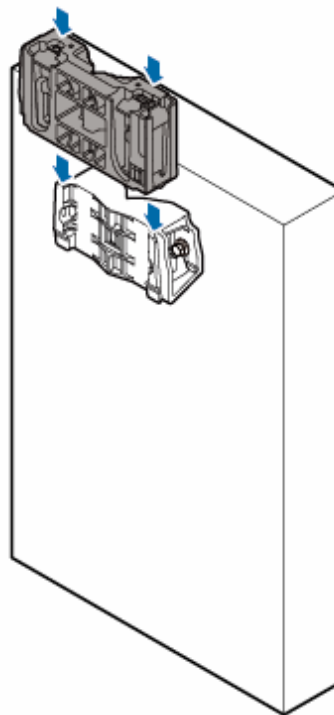

5. Install the RRU.

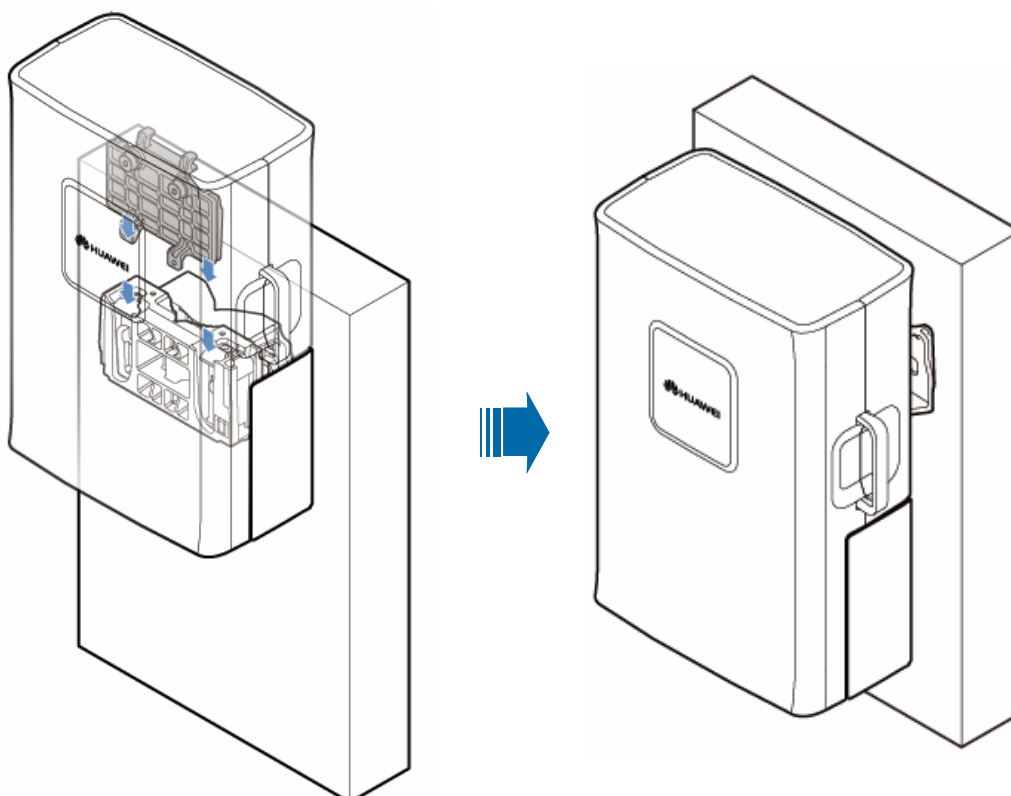

# Installing the RRU on a Wall

## 6. Install multiple RRUs.

Recommended Clearance :

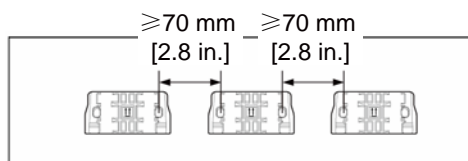
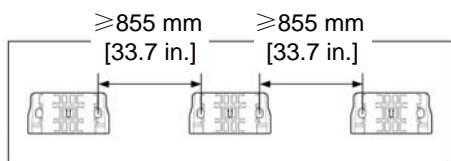

Minimum Clearance:

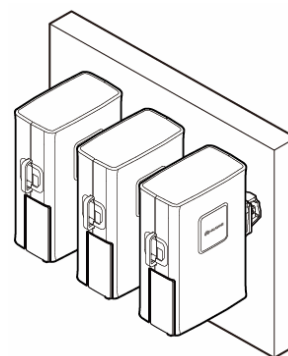
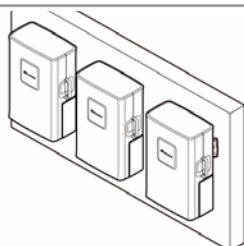
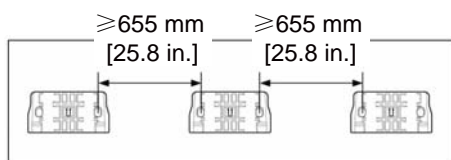

# Installing the RRU Cables

## a RRU Cable Connections

### Cable List

Cable	Connector Type	Connector to...
a PGND cable (16 mm <sup>2</sup> )	OT terminal (M6)	Grounding bolt on the RRU
	OT terminal	Nearest grounding bar
b RRU RF jumper	DIN male connector	Ports labeled ANT_TX/RXA and ANT_TX/RXB on the RRU (Only the ANT_TX/RXA port supports the OOK signal).
	DIN male connector	Feeder or antenna
c DC RRU power cable (North American standard: 3.3 mm <sup>2</sup> European standard: 4 mm <sup>2</sup> )	Two OT terminals (M4)	The blue OT terminal is connected to socket labeled NEG(-)0 in the RRU cabling cavity. And the black OT terminal is connected to socket labeled RTN(+).0.
	Bare wire	External power supply
d CPRI optical cable	DLC connector	The connectors labeled 1A and 1B are connected to the optical module on the port labeled CPRI_W on the RRU
	DLC connector	The connectors labeled 2A and 2B are connected to port labeled CPRI0 to CPRI5 on the LBBP board of the BBU.
e AISG multi-wire cable between the RRU and the RCU	Waterproof DB9 connector	Port labeled RET/MON on the RRU
	Standard AISG female connector	Standard AISG male connector of the AISG extension cable or RCU
f AISG extended cable between the RRU and the RCU	Standard AISG male connector	Standard AISG female connector of the AISG multi-wire cable
	Standard AISG female connector	Standard AISG male connector of the RCU



# Installing the RRU Cables

## a RRU Cable Connections

### Single RRU

#### NOTE

- When the length of the AISG multi-wire cable between the RRU and the RCU is not enough, you can choose the optional AISG extended cable between the RRU and the RCU.
- If the coaxial cable is used for the RET antenna when the STMA or Smart Bias-Tee (SBT) is used, the OOK signals are required. Therefore, the port for the RET antenna needs to use the ANT\_TX/RXA port.

- a PGND cable
- b RRU RF jumper
- c DC RRU power cable
- d CPRI optical cable
- e AISG multi-wire cable between the RRU and the RCU
- f AISG extended cable between the RRU and the RCU

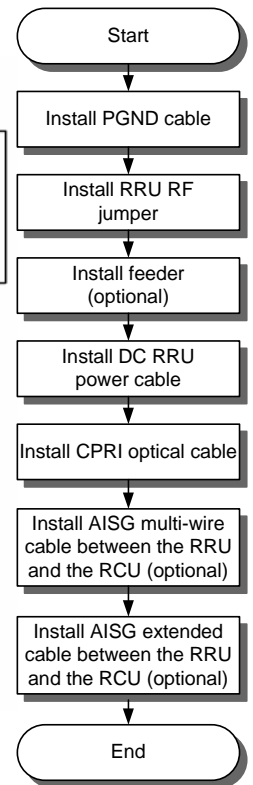
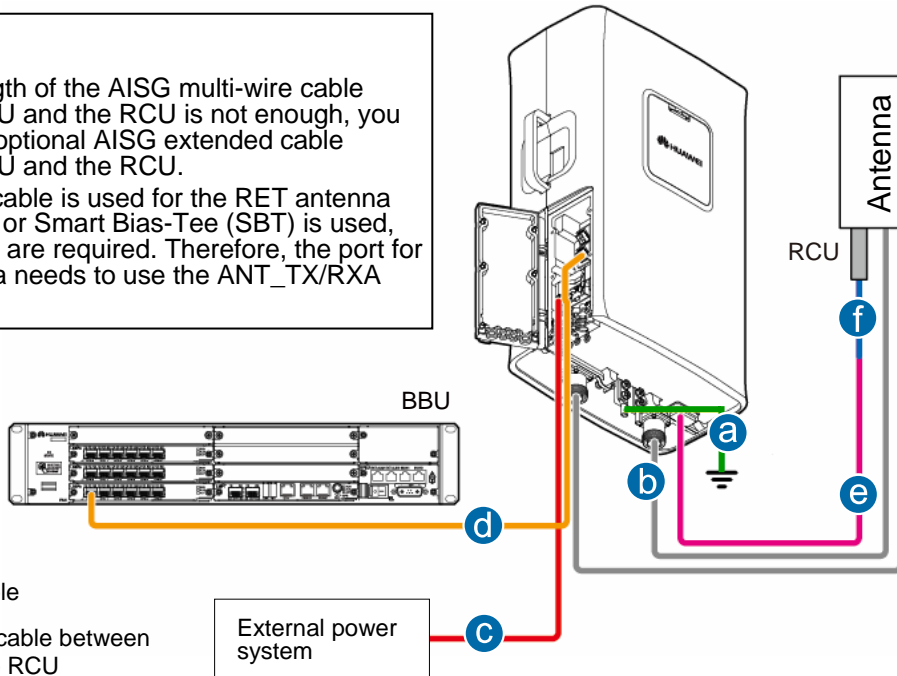

### Multiple RRUs

- a PGND cable
- b RRU RF jumper
- c DC RRU power cable
- d CPRI optical cable
- e AISG multi-wire cable between the RRU and the RCU
- f AISG extended cable between the RRU and the RCU

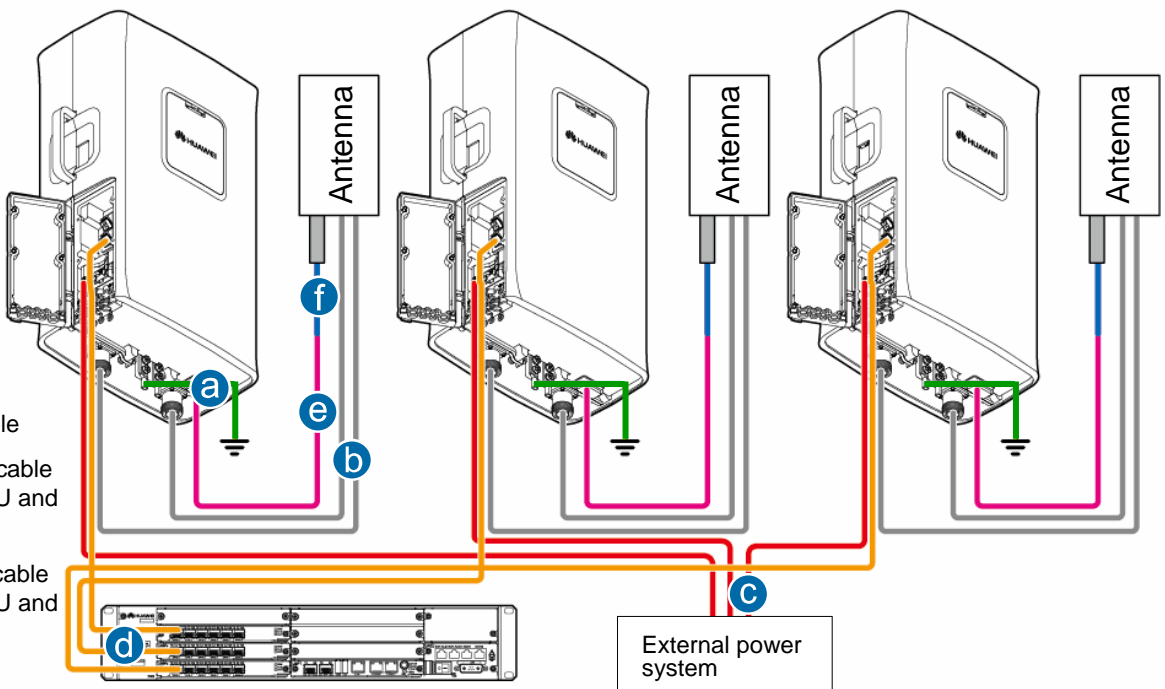

#### NOTE

For detail information of the cable, see [Cable List](#) on Page 14.



# Installing the RRU Cables

## b Opening the Cover Plate of the RRU Cabling Cavity

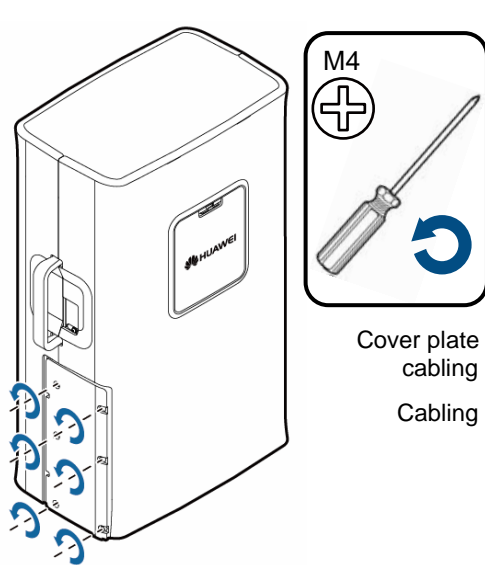

## c Cabling Cavity of the RRU

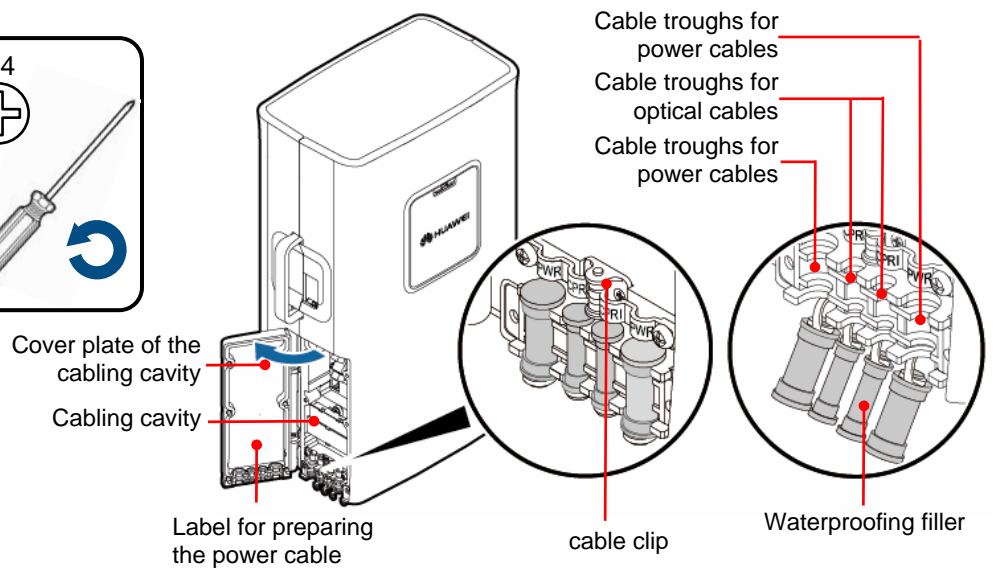

## d Cable Connections on the RRU

### CAUTION

- Before connecting a power cable, ensure that other end of the power cable not connected to any power supply.
- Use the DC RRU power cable clip to press the shielding layer tightly and ensure that the lower part of the shielding layer does not exceed the position shown in the preceding figure.
- Ground the shielding layer at the other end of the power cable.
- Do not remove the dustproof cap from the idle antenna port, and use the waterproof tape to wrap the joint.

### NOTE

- For details on how to add OT terminals to the DC RRU power cable of the RRU, see page 22 "Adding OT Terminals by Using a Wire Stripper."
- When wrapping the waterproof tape, apply even force to extend the tape until the width of the tape is 1/2 of the original width.
- Wrap the joint spirally upward, downward, and then upward again. In other words, the joint is wrapped by three layers of the tape. Ensure that the two immediate layers overlap with each other about half the width of the tape. For details, see page 24 "Waterproofing Outdoor Cables."
- Install the optical module before installing the optical cables. For details, see page 25 "Installing the Optical Module."

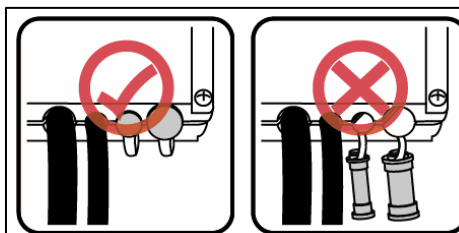
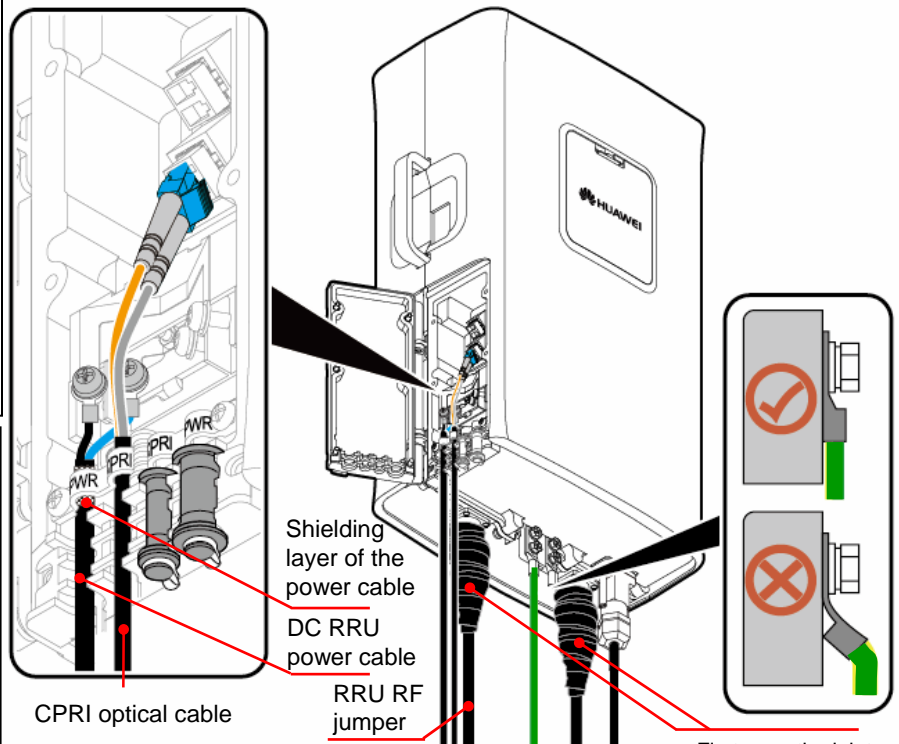

After the cables are installed on the RRU, insert the waterproofing fillers into the idle cable troughs.

# Installing the RRU Cables

## e Closing the Cover Plate of the RRU Cabling Cavity

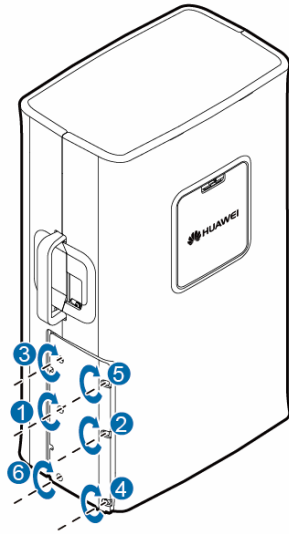
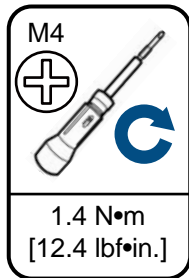

### ⚠ CAUTION

- The screws on the cover plate should be tightened until the fastening torque is 1.4 N·m [12.4 lbf·in.].
- Tighten the screws on the cover plate of the cabling cavity in the sequence shown in the figure.

## f RRU+APM30H

Grounding the shielding layer of the power cable:

- a DC RRU power cable
- b CPRI optical cable

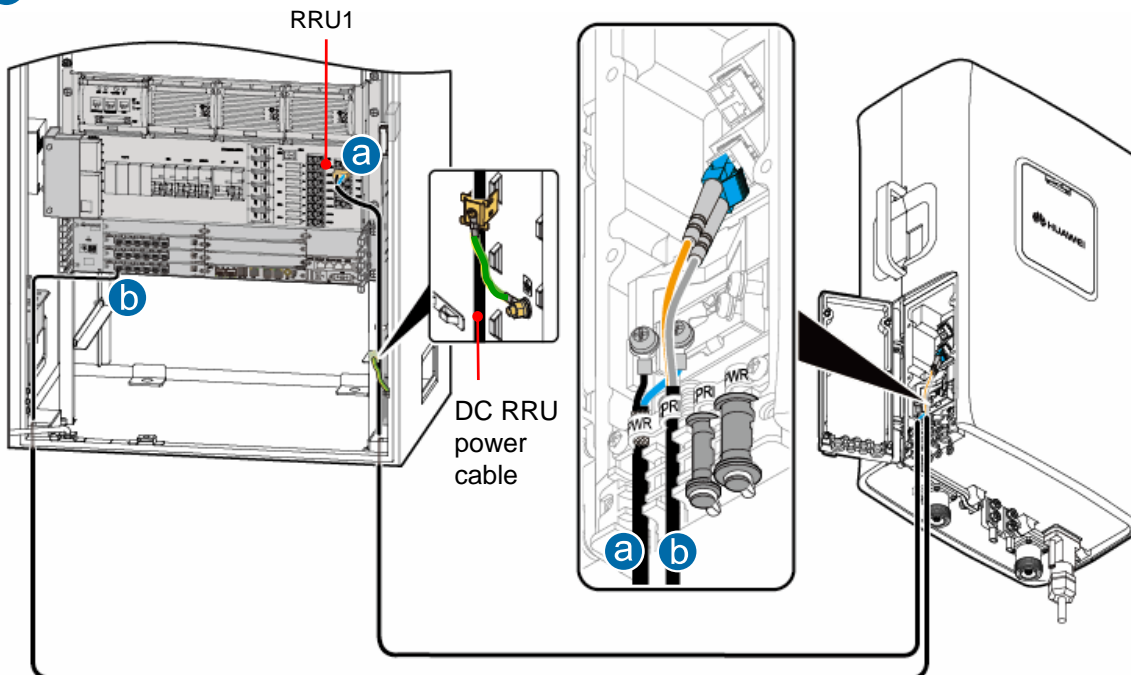
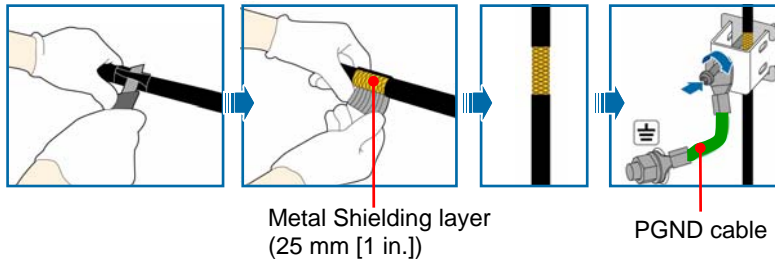

### NOTE

- The DC RRU power cable is connected to one of the RRU0 to RRU5 terminals of the PDU.
- Strip the jacket of the DC RRU power cable for a small part, press the exposed shielding layer in the power cable clip, and then connect the PGND cable on the clip to the nearest grounding bolt on the side of the cabinet.

# Installing the RRU Cables

## g RRU+BBU Installed Against the Wall

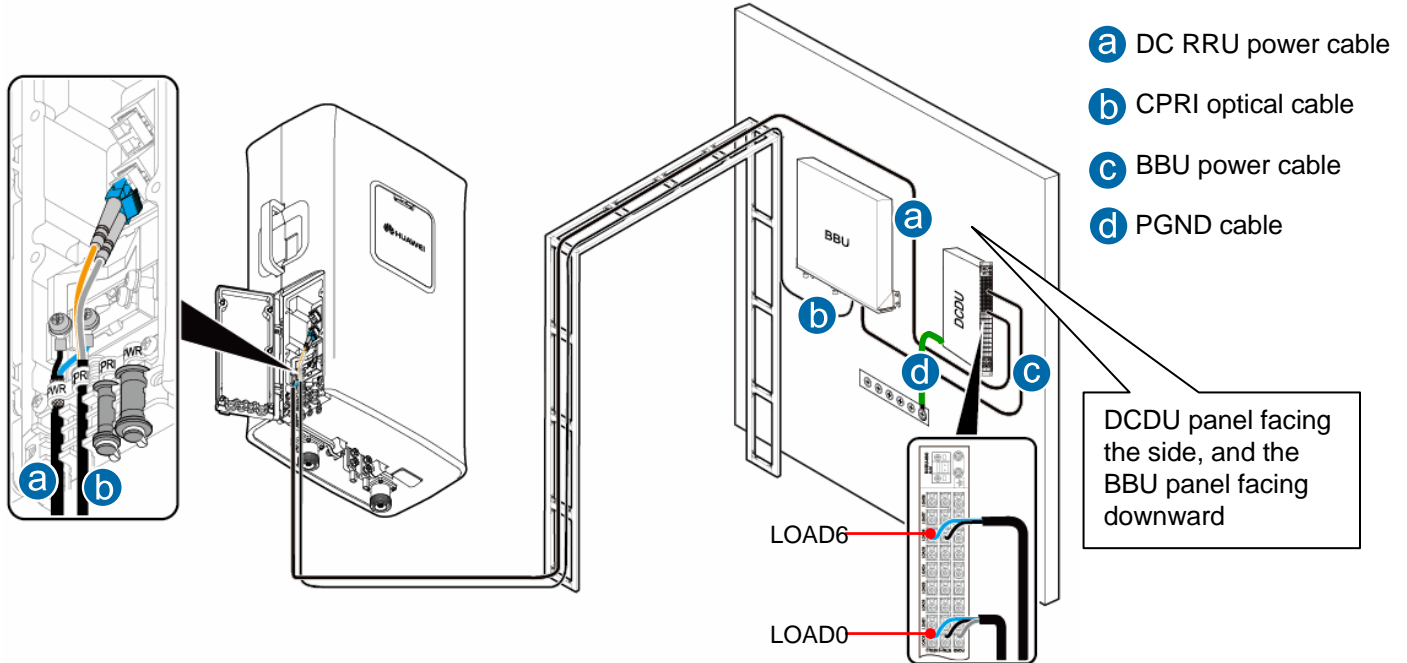

### NOTE

- The DC RRU power cable is connected to one group of the LOAD0 to LOAD5 terminals of the DCDU-03B.
- When the BBU and RRU are installed indoors, the DC RRU power cables need not to be grounded.

## h RRU+19-Inch Cabinet

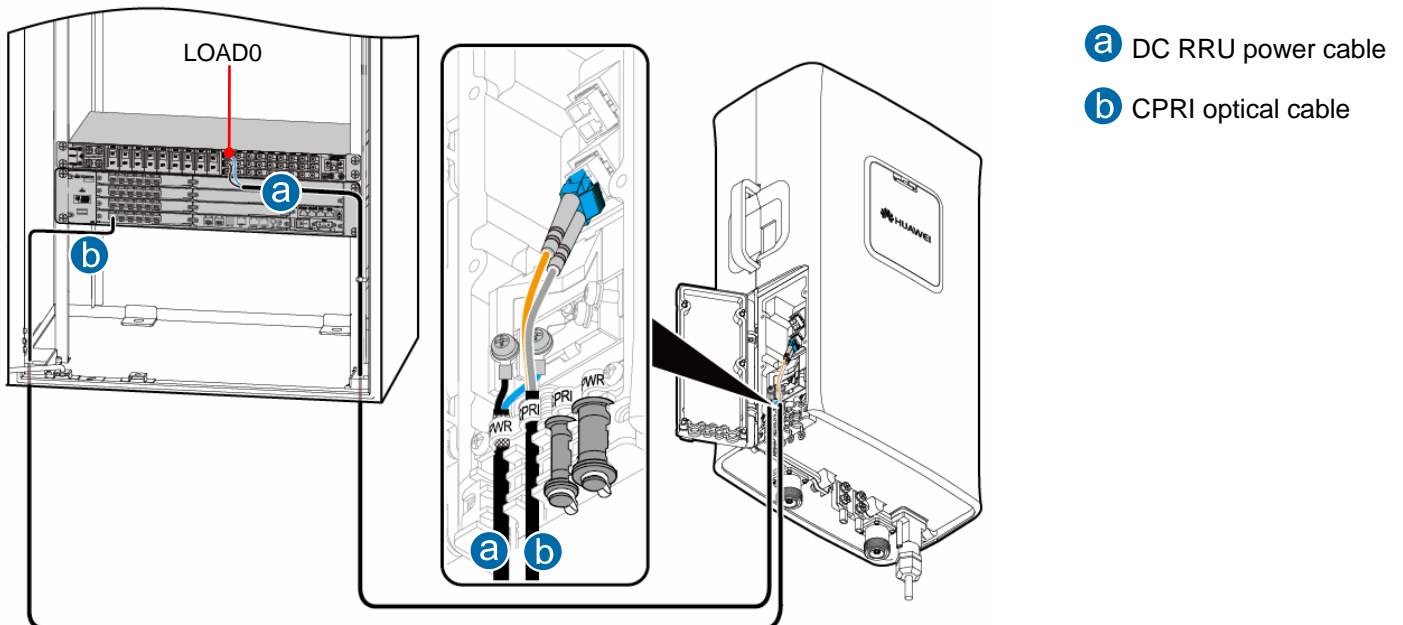

### NOTE

- At the end of the DC RRU power cable connected to the DCDU-03B, you need to make the shielding layer of the power cable into an OT terminal, and then connect the OT terminal to the PGND terminal of the corresponding port on the DCDU-03B. For details about making an OT terminal, see pages 22 and 23.
- The DC RRU power cable is connected to LOAD0 to LOAD5 on the DCDU-03B.

# Installing the RRU Cables

## i RRU+TMC/TMC11H

Grounding the shielding layer of the power cable:

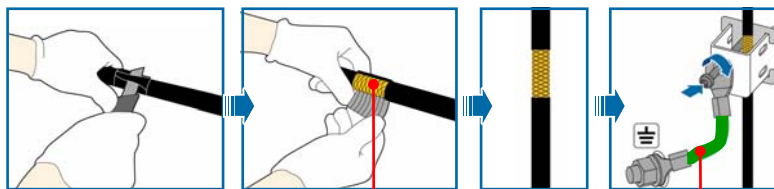

Metal Shielding layer  
(25 mm [1 in.]

PGND cable

**a** DC RRU power cable

**b** CPRI optical cable

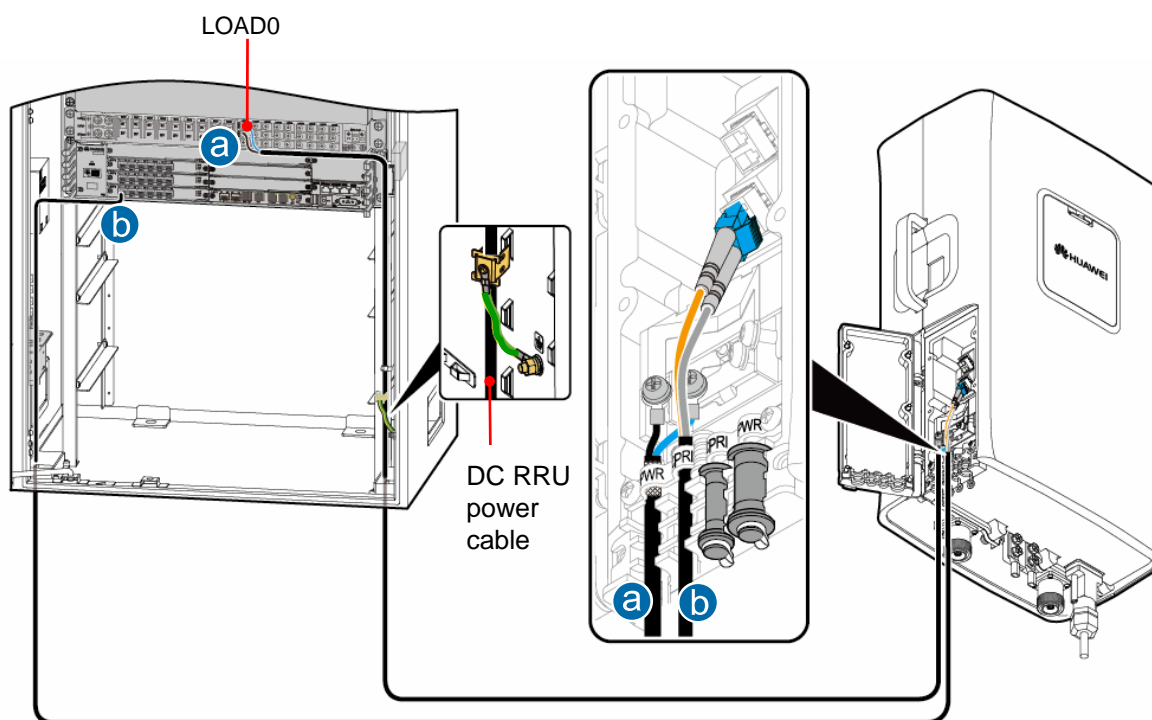

### NOTE

- At the end of the DC RRU power cable connected to the DCDU-03B, you need to make the shielding layer of the power cable into an OT terminal, and then connect the OT terminal to the PGND terminal of the corresponding port on the DCDU-03B. For details about making an OT terminal, see pages 22 and 23.
- The DC RRU power cable is connected to LOAD0 to LOAD5 on the DCDU-03B.

# RRU Hardware Installation Checklist

No.	Items
1	All self-made PGND cables are copper-based with the proper wire diameters. No breaking device such as switch and fuse is allowed for the electric connection of the grounding system. No short circuit is allowed. Each terminal on the grounding bar can be connected with only one wiring terminal of the PGND cable.
2	The RRU and the installation parts are securely installed.
3	The cover plate is securely installed on the cabling cavity of the RRU.
4	Waterproof fillers are installed in the idle cable troughs of the cabling cavity of the RRU, and the cover plate of the cabling cavity is securely installed. In addition, the idle RF ports are covered with waterproof caps and waterproofed.
5	There are no connectors or joints on the power cable or PGND cable.
6	The terminals at both ends of the power cable or PGND cable are securely soldered or crimped.
7	The flat washer and the spring washer are well mounted on all OT terminals.
8	All the power cables and PGND cables are not short-circuited or reversely connected. In addition, no damaged or broken parts exist.
9	The power cable, PGND cable, feeder, optical cable and the E1/T1/FE signal cable are bound separately with a spacing of larger than 30 mm [1.2 in.] .
10	The connector of the signal cable is intact, and no damaged or broken parts exist on the cable.
11	Labels are correct, legible, and complete on both ends of each cable.

## Powering on the RRU

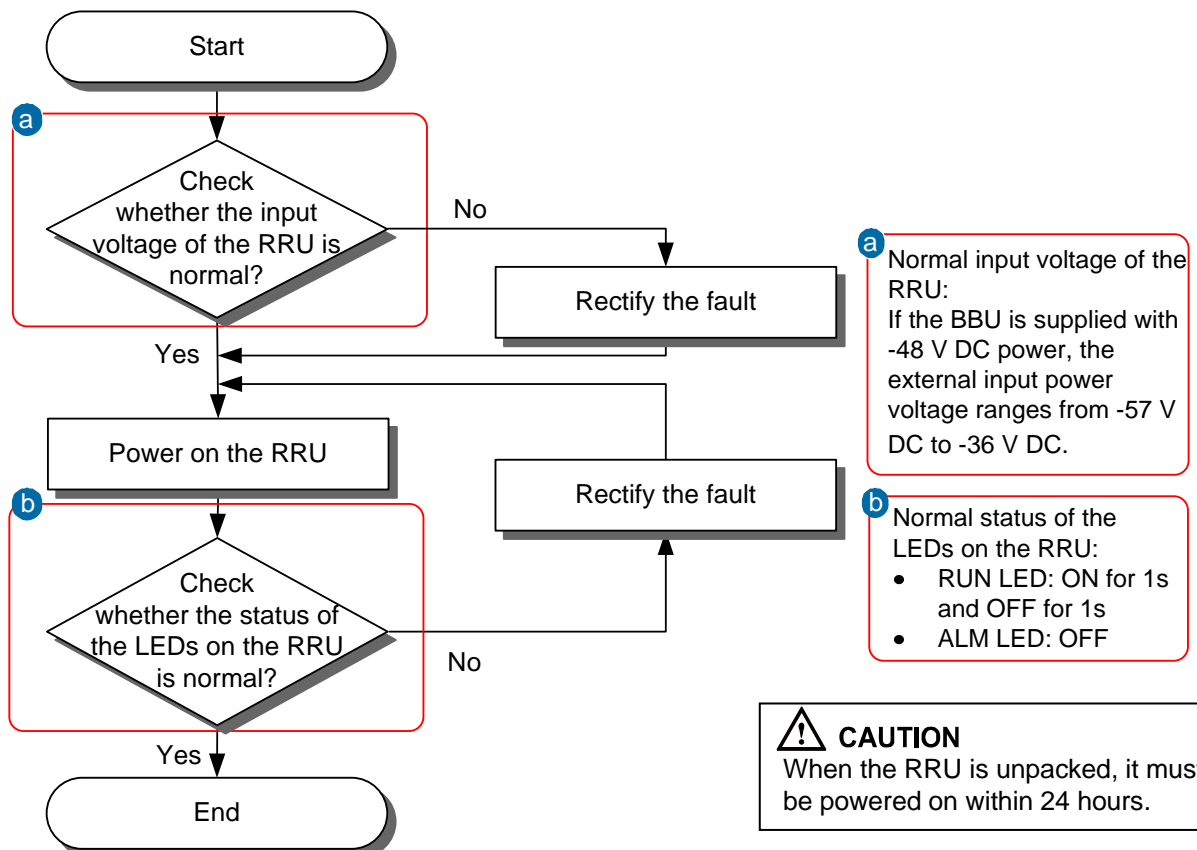

# Appendix

## a Binding the RRU and Installation Components

1. Bind the RRU by leading the lifting rope along the lower part of the adapting piece and through the handle, bind the main and auxiliary brackets with the lifting rope, and then bind the steering rope with the handle of the RRU, as shown in the following figures.

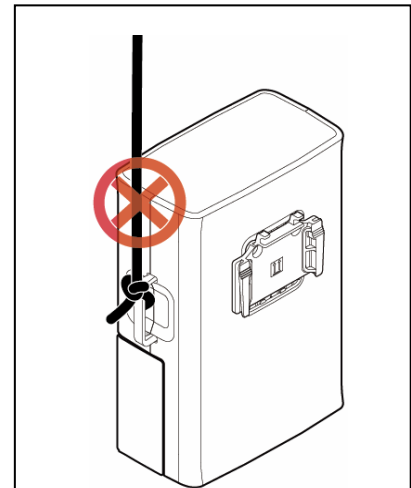
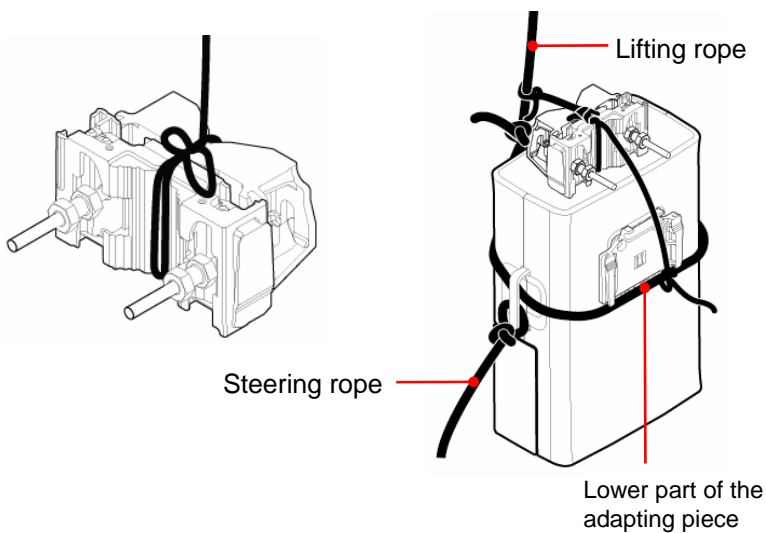

### ⚠ CAUTION

- When lifting the RRU and installation components to the tower, prevent the RRU from colliding with the tower.
- Lift the RRU to the tower before it is installed on the metal pole, angle steel, or U-steel.

### ⚠ CAUTION

- Do not bind the lifting rope only on the handle when lifting the RRU.

2. Lift the RRU and installation components to the tower.

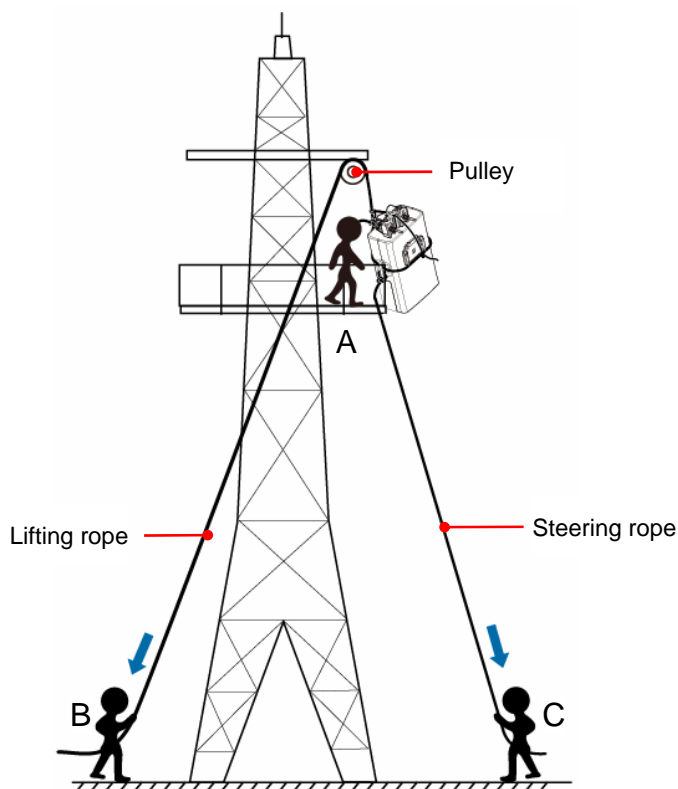

### 📖 NOTE

- Installer A climbs onto the tower. Then, installer A fixes the pulley to the support of the tower platform and leads the lifting rope through the pulley.
- Installer C uses a lifting rope to bind the RRU and installation components as shown in the preceding figure and then ties a knot in the steering rope at the handle of the RRU.
- Installer B pulls the lifting rope, and at the same time, installer C pulls the steering rope away from the tower to prevent the RRU and installation components from colliding with the tower.
- Installer A holds the RRU and installation components and untie the ropes.



# Appendix

## b Adding OT Terminals by Using a Wire Stripper (Recommended)

Adding the OT terminals to the power cable involves adding OT terminals to the RRU power cable and adding OT terminals to the shielding layer of the RRU power cable.

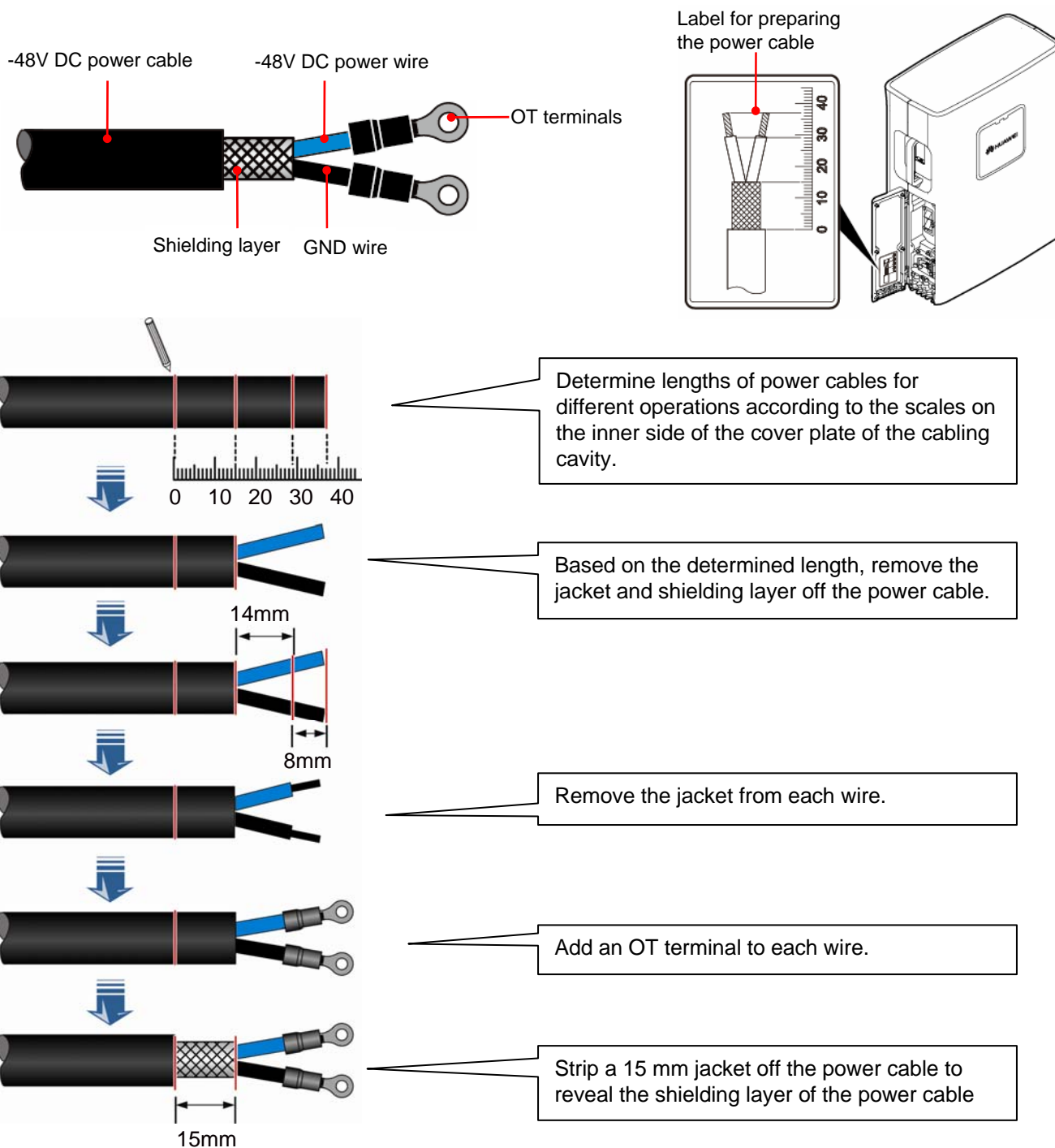

### ⚠ CAUTION

The OT terminals must be added to the power cable before the RRU is installed on a metal pole.

# Appendix

## C Adding OT Terminals to the Shielding Layer of the DC RRU Power Cable

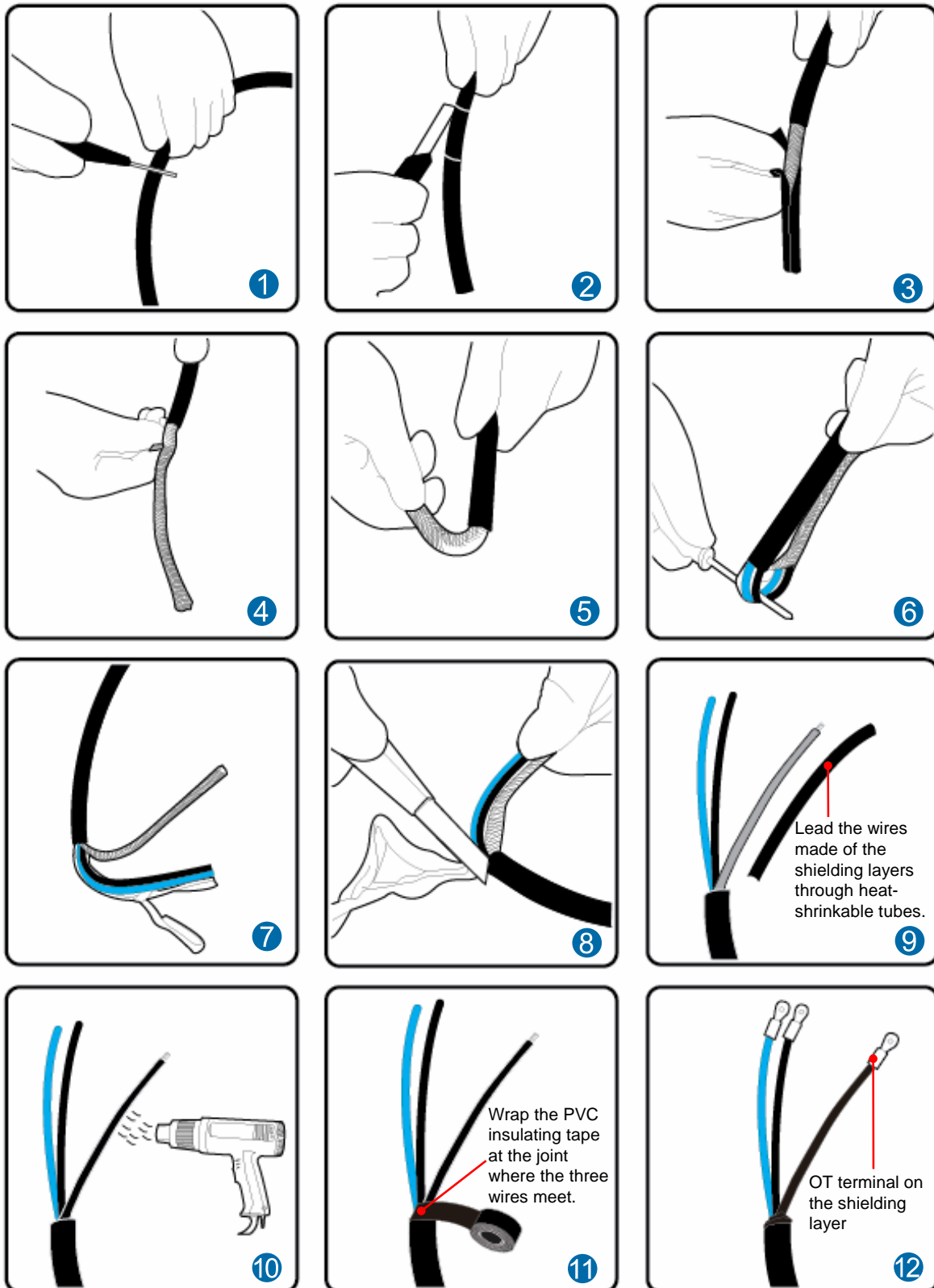

### WARNING

Do not damage the shielding layer of the power cable when cutting around the jacket.



# Appendix

## d Waterproofing Outdoor Cables

### ⚠ CAUTION

- The waterproof tape should be wrapped for an extra length of 20 mm [0.8 in.] away from the connectors at both ends.
- The tapes should be wrapped around the connector from the lower part to the upper part. When wrapped for another layer, the tapes may not be cut.
- When wrapping the waterproof tape, apply even force to extend the tape until the width of the tape is 1/2 of the original width.
- When wrapping the waterproof tape, ensure that the upper layer of the tape covers at least 50% of the lower layer.
- The insulating tape should be wrapped for an extra length of 20 mm [0.8 in.] away from the connectors at both ends.
- The last layer of the waterproof tape should be wrapped from the lower part to the upper part to prevent rainwater from infiltrating into the tape.

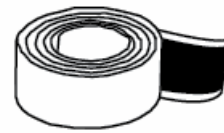

Waterproof tape

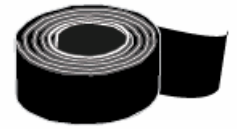

Insulating tape

### 1. Wrap three layers of waterproof tape.

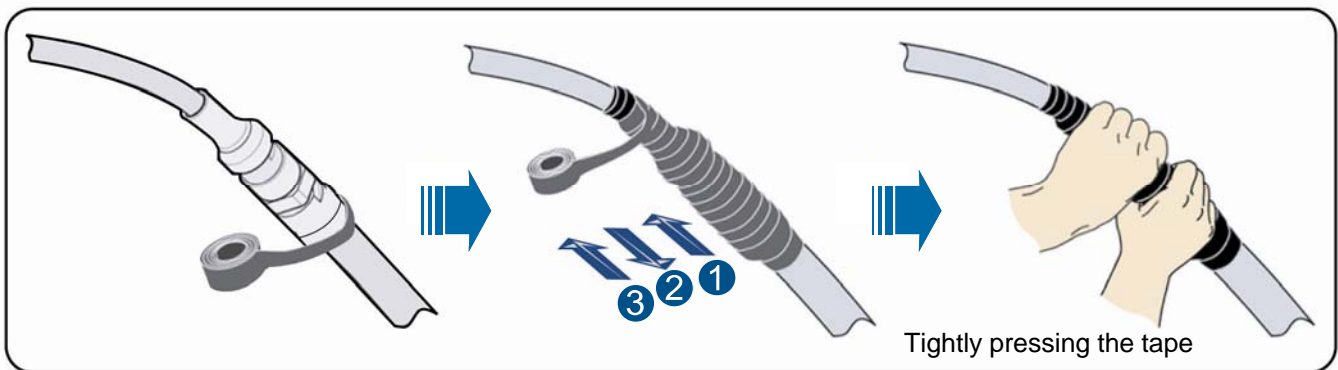

### 2. Wrap three layers of insulating tape.

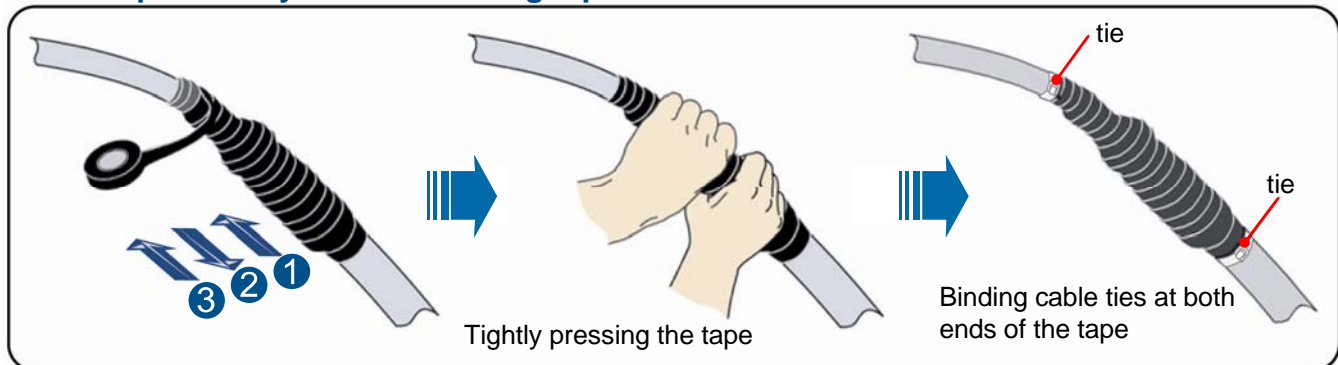

## e Installing the Optical Module

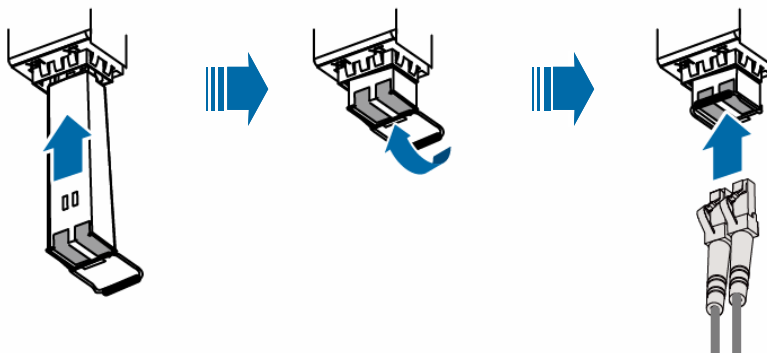

# Appendix

## f Pin Assignment of the RRU AISG Extension cable

Pin of the AISG male connector	Pin of the AISG female connector	Wire Color	Wire Type	Instruction
X1.1	X2.1	White/blue	Twisted pair	+12V
		Blue		
X1.7	X2.7	White/orange	Twisted pair	DC Return A
		Orange		
X1.3	X2.3	White/green	Twisted pair	RS485 B
X1.5	X2.5	Green		RS485 A
X1.6	X2.6	White/brown	Twisted pair	+24V
		Brown		

# Change History

This describes the changes in the *RRU3203 Installation Guide*.

●01 (2010-04-13)

This is the commercial issue.

**HUAWEI TECHNOLOGIES CO., LTD.**

Huawei Industrial Base Bantian Longgang

Shenzhen 518129

People's Republic of China

[www.huawei.com](http://www.huawei.com)