



RRU3203

Hardware Maintenance Guide

Issue 04

Date 2011-09-15

Copyright © Huawei Technologies Co., Ltd. 2011. All rights reserved.

No part of this document may be reproduced or transmitted in any form or by any means without prior written consent of Huawei Technologies Co., Ltd.

Trademarks and Permissions



HUAWEI and other Huawei trademarks are trademarks of Huawei Technologies Co., Ltd.

All other trademarks and trade names mentioned in this document are the property of their respective holders.

Notice

The purchased products, services and features are stipulated by the contract made between Huawei and the customer. All or part of the products, services and features described in this document may not be within the purchase scope or the usage scope. Unless otherwise specified in the contract, all statements, information, and recommendations in this document are provided "AS IS" without warranties, guarantees or representations of any kind, either express or implied.

The information in this document is subject to change without notice. Every effort has been made in the preparation of this document to ensure accuracy of the contents, but all statements, information, and recommendations in this document do not constitute the warranty of any kind, express or implied.

Huawei Technologies Co., Ltd.

Address: Huawei Industrial Base
Bantian, Longgang
Shenzhen 518129
People's Republic of China

Website: <http://www.huawei.com>

Email: support@huawei.com

About This Document

Purpose

This document describes routine maintenance procedures for an RRU3203 (referred to as RRU in this document), such as equipment preventive maintenance and power-on and power-off operations. It also explains how to replace the RRU and optical modules.

Product Versions

The following table lists the product versions related to this document.

Product Name	Product Version
DBS3900	V100R004 and later versions
DBS3900 LTE	V100R003C00 and later versions

Intended Audience

This document is intended for:

- System engineers
- Site maintenance engineers

Organization

[1 Changes in the RRU3203 Hardware Maintenance Guide](#)

This chapter describes the changes in the *RRU3203 Hardware Maintenance Guide*.

[2 Preventative Maintenance Items for an RRU](#)

Preventative maintenance for an RRU improves the reliability of the RRU. You are advised to perform scheduled maintenance yearly.

[3 Powering On and Off an RRU](#)

After an RRU is powered on, check the status of RRU indicators and voltage. Before the RRU is powered off, follow the normal power-off or emergency power-off procedure as required.

4 Replacing an RRU

A distributed base station consists of RRUs and a BBU. Replacing an RRU interrupts all the services carried by the RRU, and alarms are generated.





5 Replacing an Optical Module

An optical module implements optical-electrical conversion, enabling optical transmission between an RRU and other devices. You must disconnect fiber optic cables from an optical module before replacing the optical module. Disconnecting the fiber optic cables interrupts the transmission of CPRI signals.

Conventions

Symbol Conventions

The symbols that may be found in this document are defined as follows.

Symbol	Description
 DANGER	Indicates a hazard with a high level of risk, which if not avoided, will result in death or serious injury.
 WARNING	Indicates a hazard with a medium or low level of risk, which if not avoided, could result in minor or moderate injury.
 CAUTION	Indicates a potentially hazardous situation, which if not avoided, could result in equipment damage, data loss, performance degradation, or unexpected results.
 TIP	Indicates a tip that may help you solve a problem or save time.
 NOTE	Provides additional information to emphasize or supplement important points of the main text.

General Conventions

The general conventions that may be found in this document are defined as follows.

Convention	Description
Times New Roman	Normal paragraphs are in Times New Roman.
Boldface	Names of files, directories, folders, and users are in boldface . For example, log in as user root .
<i>Italic</i>	Book titles are in <i>italics</i> .
Courier New	Examples of information displayed on the screen are in Courier New.

Command Conventions

The command conventions that may be found in this document are defined as follows.

Convention	Description
Boldface	The keywords of a command line are in boldface .
<i>Italic</i>	Command arguments are in <i>italics</i> .
[]	Items (keywords or arguments) in brackets [] are optional.
{ x y ... }	Optional items are grouped in braces and separated by vertical bars. One item is selected.
[x y ...]	Optional items are grouped in brackets and separated by vertical bars. One item is selected or no item is selected.
{ x y ... }*	Optional items are grouped in braces and separated by vertical bars. A minimum of one item or a maximum of all items can be selected.
[x y ...]*	Optional items are grouped in brackets and separated by vertical bars. Several items or no item can be selected.

GUI Conventions

The GUI conventions that may be found in this document are defined as follows.

Convention	Description
Boldface	Buttons, menus, parameters, tabs, window, and dialog titles are in boldface . For example, click OK .
>	Multi-level menus are in boldface and separated by the ">" signs. For example, choose File > Create > Folder .

Keyboard Operations

The keyboard operations that may be found in this document are defined as follows.

Format	Description
Key	Press the key. For example, press Enter and press Tab .
Key 1+Key 2	Press the keys concurrently. For example, pressing Ctrl+Alt+A means the three keys should be pressed concurrently.
Key 1, Key 2	Press the keys in turn. For example, pressing Alt, A means the two keys should be pressed in turn.

Mouse Operations

The mouse operations that may be found in this document are defined as follows.

Action	Description
Click	Select and release the primary mouse button without moving the pointer.
Double-click	Press the primary mouse button twice continuously and quickly without moving the pointer.
Drag	Press and hold the primary mouse button and move the pointer to a certain position.

Contents

About This Document.....	ii
1 Changes in the RRU3203 Hardware Maintenance Guide.....	1
2 Preventative Maintenance Items for an RRU.....	3
3 Powering On and Off an RRU.....	5
3.1 Powering On an RRU.....	6
3.2 Powering Off an RRU.....	6
4 Replacing an RRU.....	8
5 Replacing an Optical Module.....	11

1 Changes in the RRU3203 Hardware Maintenance Guide

This chapter describes the changes in the *RRU3203 Hardware Maintenance Guide*.

04 (2011-09-15)

This is the fourth official release.

Compared with issue 03 (2011-04-15), this issue does not add any information.

Compared with issue 03 (2011-04-15), this issue incorporates the following change:

Topic	Change Description
5 Replacing an Optical Module	Optimized the description of the feature that optical modules are hot-swappable.

Compared with issue 03 (2011-04-15), this issue does not remove any information.

03 (2011-04-15)

This is the third official release.

Compared with issue 02 (2011-03-15), this issue does not add any information.

Compared with issue 02 (2011-03-15), this issue incorporates the following change:

Topic	Change Description
4 Replacing an RRU	Added the commands for querying electronic labels of boards online.

Compared with issue 02 (2011-03-15), this issue does not remove any information.

02 (2011-03-15)

This is the second official release.

Compared with issue 01 (2011-01-20), this issue does not add any information.

Compared with issue 01 (2011-01-20), this issue incorporates the following change:

Topic	Change Description
4 Replacing an RRU	Added the procedures for querying electronic labels of boards.

Compared with issue 01 (2011-01-20), this issue does not remove any information.

01 (2011-01-20)

This is the first official release.

Compared with draft A (2010-12-15), this issue does not add any information.

Compared with draft A (2010-12-15), this issue incorporates the following change:

Topic	Change Description
4 Replacing an RRU	Optimized the figure of replacing an RRU.

Compared with draft A (2010-12-15), this issue does not remove any information.

Draft A (2010-12-15)

This is the draft.

Compared with issue 02 (2010-07-30) of V100R002C00, this issue does not add any information.

Compared with issue 02 (2010-07-30) of V100R002C00, this issue does not incorporate any change.

Compared with issue 02 (2010-07-30) of V100R002C00, this issue does not remove any information.

2 Preventative Maintenance Items for an RRU

Preventative maintenance for an RRU improves the reliability of the RRU. You are advised to perform scheduled maintenance yearly.



DANGER

While working at heights, be careful not to drop any tools, equipment, or other objects. Falling objects may cause serious injury or death. Always wear a helmet and avoid standing in the danger area.

The items in the following checklist are not mandatory but strongly recommended. [Table 2-1](#) lists the preventative maintenance items for an RRU.

Table 2-1 Preventative maintenance items for an RRU

SN	Item
1	All RRUs are properly installed and in good condition.
2	Cables are sealed properly at the entry points of the cabinet.
3	All radio frequency (RF) cables are free from wear, cuts, cracks, or other damage.
4	All RF cable connectors are sealed properly.
5	All RF cable conduits are in good condition.
6	All power cables are free from wear, cuts, cracks, or other damage.
7	All power cable connectors are in good condition.
8	All power cable conduits are in good condition.
9	All shield layers of power cables are in good condition.
10	All power cables are sealed properly.
11	All CPRI fiber optic cables are free from wear, cuts, cracks, or other damage.
12	All screws are tightened on the cover plate of the maintenance cavity.

SN	Item
13	All RET cables (optional) are free from wear, cuts, cracks, or other damage.
14	All RET cable (optional) connectors are sealed properly.

If any of the statements in the checklist cannot be complied with, perform the following corrective actions:

1. Tighten all connections.
2. Report any other faults found when filling in the checklist to the supervisor, because only technically-qualified and trained field engineers are permitted to climb towers for further repairs.

3 Powering On and Off an RRU

About This Chapter

After an RRU is powered on, check the status of RRU indicators and voltage. Before the RRU is powered off, follow the normal power-off or emergency power-off procedure as required.

[3.1 Powering On an RRU](#)

Set the corresponding circuit breaker on the auxiliary power device for the RRU to ON, and check the operating status of the RRU by observing the status of RRU indicators.

[3.2 Powering Off an RRU](#)

An RRU can be powered off in two ways: normal power-off and emergency power-off. You must power off an RRU in a normal situation such as moving the equipment or anticipating a territorial blackout. You must also power off an RRU in an emergency such as a fire, smoke, or water immersion occurs in the equipment room.

3.1 Powering On an RRU

Set the corresponding circuit breaker on the auxiliary power device for the RRU to ON, and check the operating status of the RRU by observing the status of RRU indicators.

Prerequisite

- The RRU hardware is installed and RRU cable connections are secure.
- The input voltage of the RRU ranges from -36 V DC to -57 V DC.

Context



CAUTION

After you unpack an RRU, you must power on it within 24 hours. If you power off the RRU for maintenance, you must restore power to the RRU within 24 hours.

Procedure

- Step 1** Set the corresponding circuit breaker on the auxiliary power device for the RRU to ON to power on the RRU.



DANGER

Do not look into the optical module without eye protection after the RRU is powered on.

- Step 2** Keep the RRU running for three to five minutes to check the status of RRU indicators. For details, see RRU Indicators.

- Step 3** Take corresponding actions based on the status of the indicators.

If...	Then...
The RRU is working properly	End the power-on check task.
The RRU is faulty	Set the circuit breaker to OFF. Rectify the fault, and then go to Step 1 .

----End

3.2 Powering Off an RRU

An RRU can be powered off in two ways: normal power-off and emergency power-off. You must power off an RRU in a normal situation such as moving the equipment or anticipating a

territorial blackout. You must also power off an RRU in an emergency such as a fire, smoke, or water immersion occurs in the equipment room.

Procedure

- Normal power-off
 1. Set the corresponding circuit breaker on the auxiliary power device for the RRU to OFF.
- Emergency power-off



CAUTION

Emergency power-off may damage the RRU. Therefore, this type of power-off is not recommended in normal cases.

-
1. Shut off the external input power of the auxiliary power device for the RRU.
 2. If time permits, set the corresponding circuit breaker on the auxiliary power device for the RRU to OFF.

---End

4 Replacing an RRU

A distributed base station consists of RRUs and a BBU. Replacing an RRU interrupts all the services carried by the RRU, and alarms are generated.

Prerequisite

- The test UE communicates with the base station properly.
- The types of faulty RRUs are confirmed as follows:
 - If RRUs can be queried online, run the **DSP BRDMFRINFO** command on the LMT to query the electronic labels of the RRUs.
 - If RRUs cannot be queried online, the information about the RRUs can be queried offline on the M2000. For details, see the procedure for querying inventory data in the M2000 documentation.
- Tools and materials, such as ESD gloves, M4 Phillips screwdrivers, M6 Phillips screwdrivers, waterproof tape, and PVC insulation tape, are ready.
- The number and type of RRUs to be replaced are confirmed, and new RRUs are ready.

Procedure

- Step 1** Run the **BLK BRD** command to block the RRU.
- Step 2** Power off the RRU by referring to [3.2 Powering Off an RRU](#).
- Step 3** Wear ESD gloves.



CAUTION

- Take proper ESD protection measures, for example, wear ESD gloves, to prevent electrostatic damage to the boards, modules, or electronic components.
 - Pay attention to the high temperature while replacing an RRU without housing.
-

- Step 4** Loosen the six screws on the cover plate of the RRU cabling cavity using an M4 Phillips screwdriver, and then open the cover plate.
- Step 5** Record all the cable connections on the panel of the module to be replaced.

Step 6 Disconnect cables from the cabling cavity and bottom panel.

Step 7 Loosen the captive screws on the two hoist clamps on the main mounting bracket using an M4 Phillips screwdriver, as shown in [Figure 4-1](#).



NOTE

In scenarios where RRUs are installed in centralized mode, the RRU in the middle can be removed without removing the two RRUs on its right and left sides, in the same procedure as that for removing a single RRU.

Figure 4-1 Loosening captive screws on the main mounting bracket

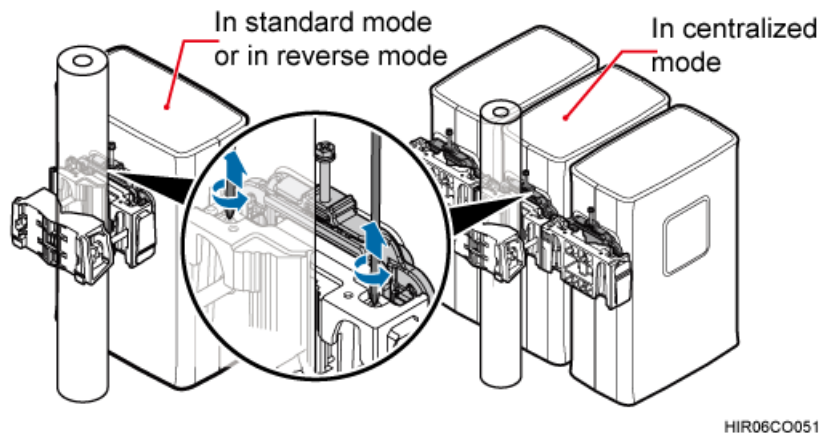

Step 8 Tighten the screws on the attachment plate of the RRU using an M6 Phillips screwdriver, as shown in [Figure 4-2](#). Use the screw only for removing the RRU to loosen the connection between the attachment plate and the main mounting bracket, and then support the RRU bottom to remove it, as shown in [Figure 4-3](#).

Figure 4-2 Tightening screws on the attachment plate

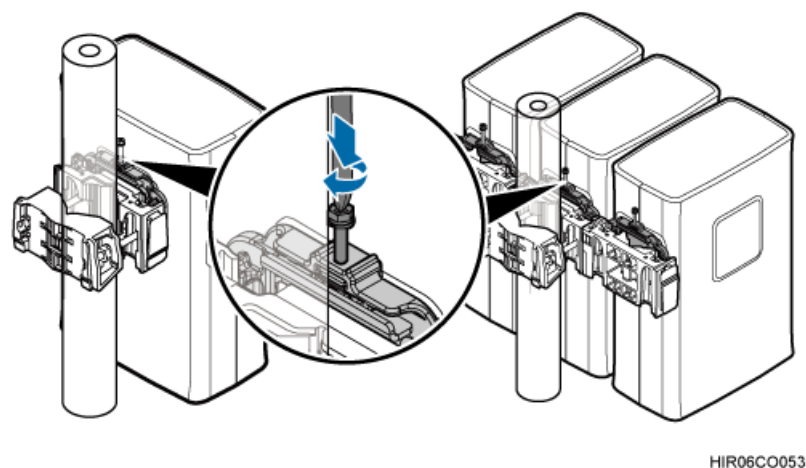
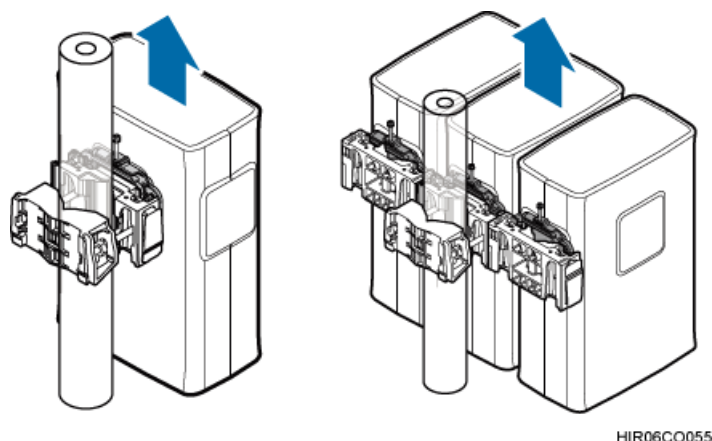

Figure 4-3 Supporting the RRU bottom



 **CAUTION**

When removing the RRU, hold the RRU handle with one hand and support the RRU bottom with the other hand.

- Step 9** Tighten the captive screws on the two hoist clamps on the main mounting bracket to 1.4 N·m (12.39 lbf·in.). Install a new RRU and then waterproof the RRU.
- Step 10** Reconnect all required cables, and verify that vacant cable troughs in the cabling cavity are equipped by waterproof blocks.
- Step 11** Close the cover plate of the RRU cabling cavity, and then tighten the protection screw on the cover plate to 1.4 N·m (12.39 lbf·in.).
- Step 12** Power on the RRU by referring to [3.1 Powering On an RRU](#).
- Step 13** Check the operating status of the new RRU by observing the status of RRU indicators. For details about the status of the indicators, see RRU Indicators.
- Step 14** Run the **UBL BRD** command to unblock the RRU.
- Step 15** Take off the ESD gloves, and pack up all the tools.

----End

Follow-up Procedure

- Place the removed RRU into the ESD box or bag. Then, place the ESD box or bag into a foam-padded carton or the packing box of the new RRU.
- Fill in the fault form with detailed information about the removed component.
- Contact the local Huawei office to handle the faulty component.

5 Replacing an Optical Module

An optical module implements optical-electrical conversion, enabling optical transmission between an RRU and other devices. You must disconnect fiber optic cables from an optical module before replacing the optical module. Disconnecting the fiber optic cables interrupts the transmission of CPRI signals.

Prerequisite

- The type and number of optical modules to be replaced are confirmed, and new optical modules are ready.
- Tools and materials, such as ESD gloves, M4 Phillips screwdrivers, and an ESD box or bag, are ready.

Context

- Optical modules are inserted into CPRI_W and CPRI_E ports on an RRU.
- Optical modules are hot-swappable when the same CPRI ports are used.
- It takes about five minutes to replace an optical module on the RRU, which involves disconnecting fiber optic cables, removing the faulty optical module, inserting a new optical module, reconnecting the fiber optic cables, and waiting for CPRI links to resume.

Procedure

Step 1 Wear ESD gloves.



CAUTION

Take proper ESD protection measures, for example, wear ESD gloves, to prevent electrostatic damage to the boards, modules, or electronic components.

Step 2 Loosen the six screws on the cover plate of the RRU cabling cavity using an M4 Phillips screwdriver, and then open the cover plate.

Step 3 Record the connections of the optical module and fiber optic cables.

Step 4 Press the latch on the fiber optic cable connector, and then remove the connector from the faulty optical module.



WARNING

Do not look into the fiber optic cable or optical module without eye protection after the fiber optic cable is removed from the optical module.

Step 5 Lower the puller on the faulty optical module, and then pull the puller until the optical module is removed from the RRU.

Step 6 Choose the optical module of the same type as the faulty optical module according to the label on the module. Install a new optical module into the RRU.



NOTE

The optical modules to be installed must match CPRI rates.

Step 7 Insert the fiber optic cable connector into the new optical module.

Step 8 Check the transmission of CPRI signals by observing the status of CPRI_W and CPRI_E indicators. For details about the status of the indicators, see RRU Indicators.

Step 9 Reconnect the cables in the cabling cavity.

Step 10 Close the cover plate of the RRU cabling cavity, and then tighten the protection screw on the cover plate to 1.4 N·m (12.39 lbf·in.).

Step 11 Take off the ESD gloves, and pack up all the tools.

----End

Follow-up Procedure

- Place the removed optical module into the ESD box or bag. Then, place the ESD box or bag into a foam-padded carton or the packing box of the new module.
- Fill in the fault form with detailed information about the removed component.
- Contact the local Huawei office to handle the faulty optical module.